

















Linear drives DGCI, with displacement encoder



# Cylinders with displacement encoder

Product range overview

Function	Type	Brief description
Drives	<b>Rodless</b>	
	DDLI 	<ul style="list-style-type: none"> <li>• Without guide</li> <li>• With contactless measuring displacement encoder</li> <li>• Based on linear drive DGC-K</li> <li>• Supply ports on end face</li> <li>• System product for handling and assembly technology</li> </ul>
	DDCI 	<ul style="list-style-type: none"> <li>• With guide</li> <li>• With contactless measuring displacement encoder</li> <li>• Based on linear drive DGC</li> <li>• Supply ports optionally on end face or front</li> <li>• System product for handling and assembly technology</li> </ul>
	DGP/ DGPIL 	<p><b>Do not use for new projects!</b></p> <ul style="list-style-type: none"> <li>• With or without guide</li> <li>• With contactless measuring displacement encoder, integrated</li> <li>• Wide range of options for mounting on drives</li> <li>• System product for handling and assembly technology</li> </ul>
	DGP/ DGPL 	<p><b>Do not use for new projects!</b></p> <ul style="list-style-type: none"> <li>• With or without guide</li> <li>• With potentiometer or contactless measuring displacement encoder, attached</li> <li>• With clamping unit</li> <li>• Wide range of options for mounting on drives</li> </ul>
	<b>With piston rod</b>	
	DNCI 	<ul style="list-style-type: none"> <li>• With contactless measuring displacement encoder</li> <li>• Various piston rod variants</li> <li>• Standards-based cylinder to ISO 15552</li> </ul> <p>    </p>
	DDPC 	<ul style="list-style-type: none"> <li>• With contactless measuring displacement encoder</li> <li>• Various piston rod variants</li> <li>• Standards-based cylinder to ISO 15552</li> </ul> <p>    </p>
	DNC/ DSBC 	<ul style="list-style-type: none"> <li>• With attached potentiometer MLO-LWG</li> <li>• Various piston rod variants</li> <li>• Standards-based cylinder to ISO 15552</li> </ul> <p>    </p>
	Swivel modules	<b>Swivel modules</b>
DSMI 		<ul style="list-style-type: none"> <li>• Based on swivel modules DSM</li> <li>• Integrated rotary potentiometer</li> <li>• Compact design</li> <li>• Wide range of mounting options</li> </ul>

# Cylinders with displacement encoder

Product range overview

FESTO

Piston Ø	Stroke/swivel angle [mm/°]	Suitable				
		for positioning with		for end-position controller		for use as a measuring cylinder
		CPX-CMAX	SPC200	CPX-CMPX	SPC11	
<b>Rodless</b>						
25, 32, 40	100, 160, 225, 300, 360, 450, 500, 600, 750, 850, 1000, 1250, 1500, 1750, 2000	■	■	■	■	■
18, 25, 32, 40, 63	100, 160, 225, 300, 360, 450, 500, 600, 750, 850, 1000, 1250, 1500, 1750, 2000	■	■	■	■	■
25, 32, 40, 50, 63	225, 300, 360, 450, 500, 600, 750, 1000, 1250, 1500, 1750, 2000	■	■	■	■	■
25, 32, 40, 50, 63	225, 300, 360, 450, 500, 600, 750, 1000, 1250, 1500, 1750, 2000	-	■	-	■	■
<b>With piston rod</b>						
32, 40, 50, 63	10 ... 2000	-	-	-	-	■
	100 ... 750	■	■	■	■	-
80, 100	10 ... 2000	-	-	-	-	■
	100 ... 750	■	■	■	■	-
32, 40, 50, 63, 80	100, 150, 225, 300, 360, 450, 600, 750	■	■	■	■	■
<b>Swivel modules</b>						
25, 40, 63	270	■	■	■	■	■

# Cylinders with displacement encoder

Features

FESTO

## Servopneumatic drive technology

Positioning and Soft Stop applications as an integral component of the valve terminal CPX – the modular peripheral system for decentralised automation tasks.

The modular design means that valves, digital inputs and outputs, positioning modules and end-position controllers, as appropriate to the application, can be combined in almost any way on the CPX terminal.

Advantages:

- Pneumatics and electrics – control and positioning on one platform
- Innovative positioning technology – piston rod drives, rodless drives, rotary drives
- Actuation via fieldbus
- Remote maintenance, remote diagnostics, web server, SMS and e-mail alerts are all possible via TCP/IP
- Modules can be quickly exchanged and expanded without altering the wiring

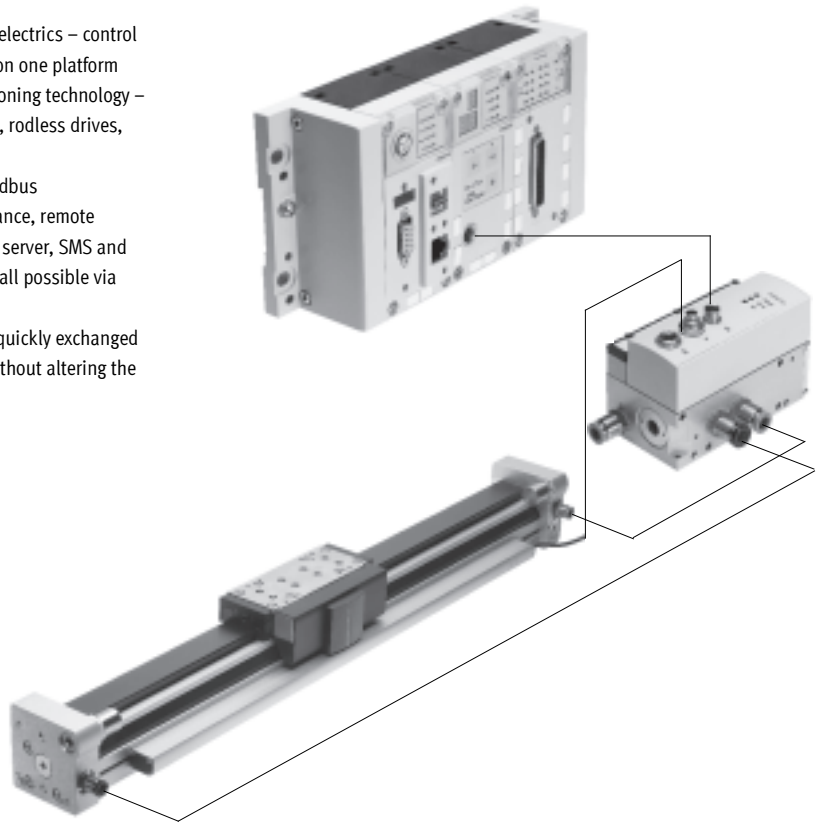

## Axis controller CPX-CMAX



Free choice:

Position and force control, directly actuated or selected from one of 64 configurable position sets. If you are looking for something more: the configurable function for switching to the next set enables simple functional sequences to be realised with the axis controller CPX-CMAX.

All stations are recognised as: the auto-identification function identifies each participant with its device data on the controller CPX-CMAX.

Also included:

The functional scope of the controller CPX-CMAX includes actuation of a brake or clamping unit via the proportional directional control valve VPWP.

Up to 8 modules (max. 8 axes) can be operated in parallel and independently of each other. Commissioning via FCT (Festo configuration software) or via fieldbus: no programming, only configuration.

Technical data → Internet: [cpx-cmax](http://cpx-cmax)

Advantages:

- Greater flexibility
- OEM friendly – commissioning also via fieldbus
- Easy installation and fast commissioning
- Cost-effective
- You program the system in your PLC environment

# Cylinders with displacement encoder

Features

FESTO

## End-position controller CPX-CMPX



Fast travel between the mechanical end stops of the cylinder, stopping gently and without impact in the end position.  
Fast commissioning via control panel, fieldbus or handheld unit. Improved control of downtime. Actuation of a brake or clamping unit via the proportional directional control valve VPWP is an integral part of the controller CMPX.

Depending on the fieldbus chosen, up to 9 end-position controllers can be actuated on the CPX terminal. All system data can be read and written via the fieldbus, including, for example, the mid positions.

### Technical data → Internet: cpx-cmpx

- Advantages:
- Greater flexibility
  - OEM friendly – commissioning also via fieldbus
  - Easy installation and fast commissioning
  - Cost-effective
    - up to 30% faster cycle rates
    - significantly reduced system vibration
  - Improved work ergonomics thanks to significantly reduced noise level
  - The extended diagnostics help to reduce the service time of the machine

## Proportional directional control valve VPWP



The 5/3-way proportional directional control valve for applications with Soft Stop and pneumatic positioning. Fully digitalised – with integrated pressure sensors, with new diagnostic functions. In sizes 4, 6, 8 and 10. Flow rate of 350, 700, 1400 and 2000 l/min.

With switching output for actuating a brake. Coloured supply ports. Pre-assembled cables guarantee faultless and fast connection with the controllers CPX-CMPX and CPX-CMAX.

### Technical data → Internet: vpwp

- Advantages:
- Easy installation and fast commissioning
  - Reduction of system downtimes thanks to the new diagnostic options
  - With switching output for actuating a brake/clamping unit

## Measuring module CPX-CMIX



Fully digital data acquisition and transmission means that pneumatic cylinders can be used as sensors. With very high repetition accuracy and incorporating both analogue and digital measuring sensors.

Suitable for the linear drive DGCI with displacement encoder for measuring absolute values, for the piston rod drive DNCI/DDPC with incremental displacement encoder or even for a potentiometer of the type MLO.

### Technical data → Internet: cpx-cmix

- Advantages:
- All process steps can be documented, which improves quality
  - An adjustable contact force (via pressure regulator) increases the precision of the "displacement sensor"
  - With displacement encoders for measuring absolute values, the actual position is immediately available after the system is switched on

# Cylinders with displacement encoder

Drive options

FESTO

## System with linear drive DDLI, DGCI

Technical data → Internet: [ddli](#) or [dgci](#)

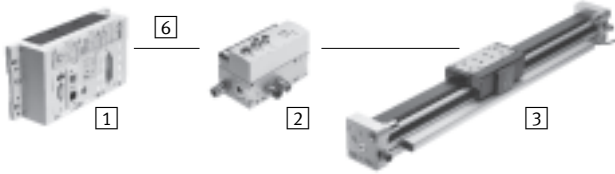

- 1 Controller module CPX-CMPX or CPX-CMAX
- 2 Proportional directional control valve VPWP
- 3 Linear drive DDLI, DGCI with displacement encoder
- 6 Connecting cable KVI-CP-3-...

- Pneumatic rodless linear drive with displacement encoder, with or without recirculating ball bearing guide
- Displacement encoder with absolute and contactless measurement
- Diameters:
  - DGCI: 18 ... 63 mm
  - DDLI: 25 ... 40 mm
- Stroke: 100 ... 2000 mm in fixed lengths
- Range of applications: Soft Stop and pneumatic positioning
- Loads from 1 ... 180 kg
- No sensor interface required

Advantages:

- Complete drive unit
- DDLI for easy connection to customer's guide system
- Excellent running characteristics
- For fast and accurate positioning down to  $\pm 0.2$  mm (only with axis controller CPX-CMAX)

## System with linear drive DGPI, DGPII or displacement encoder MME-MTS

Technical data → Internet: [dgpI](#)

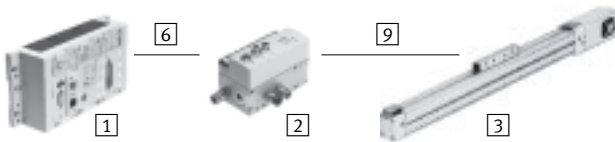

- 1 Controller module CPX-CMPX or CPX-CMAX
- 2 Proportional directional control valve VPWP
- 3 Linear drive DGPI, DGPII with displacement encoder
- 6 Connecting cable KVI-CP-3-...
- 9 NEBP-M16W6-K-2-M9W5

- Pneumatic rodless linear drive with displacement encoder, with or without recirculating ball bearing guide
- Displacement encoder with absolute and contactless measurement
- Diameter: 25 ... 63 mm
- Stroke: 225 ... 2000 mm in fixed lengths
- Range of applications: Soft Stop and pneumatic positioning
- Loads from 2 ... 180 kg
- No sensor interface required

Advantages:

- Complete drive unit
- DGPI for easy connection to customer's guide system
- Excellent running characteristics
- For fast and accurate positioning down to  $\pm 0.2$  mm (only with axis controller CPX-CMAX)

## System with standard cylinder DNCI, DDPC

Technical data → Internet: [dnCI](#)

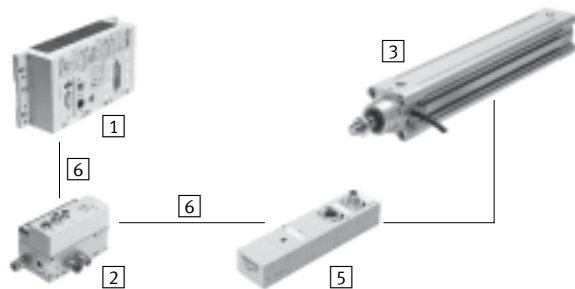

- 1 Controller module CPX-CMPX or CPX-CMAX
- 2 Proportional directional control valve VPWP
- 3 Standard cylinder DNCI, DDPC with displacement encoder
- 5 Sensor interface CASM-S-D3-R7
- 6 Connecting cable KVI-CP-3-...

- Standard cylinder with integrated displacement encoder, conforms to DIN ISO 6432, VDMA 24 562, NF E 49 003.1 and Uni 10 290
- Displacement encoder with contactless and incremental measuring
- Diameter: 32 ... 100 mm
- Stroke: 100 ... 750 mm
- Range of applications: Soft Stop and pneumatic positioning
- Loads from 3 ... 450 kg and a matching sensor interface CASM-S-D3-R7
- Pre-assembled cables guarantee faultless and fast electrical connection

Advantages:

- Compact drive unit
- Can be used universally
- Also with guide unit
- For fast and accurate positioning up to  $\pm 0.5$  mm (only with axis controller CPX-CMAX)

# Cylinders with displacement encoder

Drive options

FESTO

## System with swivel module DSMI

Technical data → Internet: [dsmi](#)

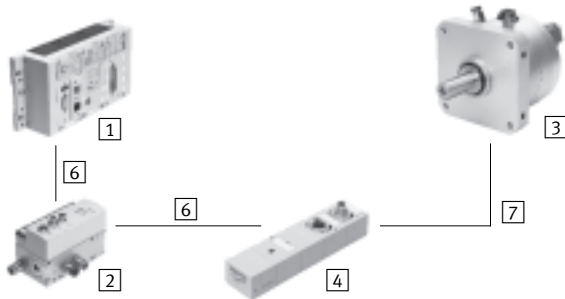

- 1 Controller module CPX-CMPX or CPX-CMAX
- 2 Proportional directional control valve VPWP
- 3 Swivel module DSMI with displacement encoder
- 4 Sensor interface CASM-S-D2-R3
- 6 Connecting cable KVI-CP-3-...
- 7 Connecting cable NEBC-P1W4-K-0,3-N-M12G5

- Swivel module DSMI with integrated displacement encoder
- Identical design to pneumatic swivel module DSM
- Absolute displacement encoder based on a potentiometer
- Swivel range of 0 ... 270°
- Size: 25, 40, 63
- Max. torque: 5 ... 40 Nm
- Range of applications: Soft Stop and pneumatic positioning
- Mass moments of inertia from 15 ... 6000 kgcm<sup>2</sup> and a matching sensor interface CASM-S-D2-R3
- Pre-assembled cables guarantee faultless and fast connection with the proportional directional control valve VPWP

Advantages:

- Complete drive unit, compact, can be used immediately
- High angular acceleration
- With adjustable fixed stops
- For fast and accurate positioning down to ±0.2° (only with axis controller CPX-CMAX)

## System with potentiometer

Technical data → Internet: [casm](#)

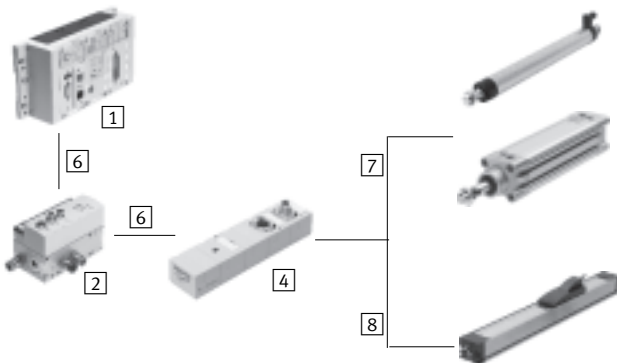

- 1 Controller module CPX-CMPX or CPX-CMAX
- 2 Proportional directional control valve VPWP
- 4 Sensor interface CASM-S-D2-R3
- 6 Connecting cable KVI-CP-3-...
- 7 Connecting cable NEBC-P1W4-K-0,3-N-M12G5
- 8 Connecting cable NEBC-A1W3-K-0,4-N-M12G5

- Attachable potentiometers with absolute measurement, with high degree of protection
- With connecting rod or moment compensator
- Measuring range: 100 ... 2000 mm
- Pre-assembled cables guarantee faultless and fast connection with the sensor interface CASM
- Range of applications: Soft Stop and pneumatic positioning with cylinder Ø 25 ... 80 mm, e.g. DNC or DSBC
- Loads from 1 ... 300 kg

Advantages:

- Easy installation and fast commissioning
- Cost-effective
- Can also be used in harsh ambient conditions
- Variety of drives: CPX-CMPX and CPX-CMAX also support cylinders with external displacement encoder

# Cylinders with displacement encoder

Drive options

System components for Soft Stop systems with end-position controller CPX-CMPX							
	Linear drive		Standard cylinder	Swivel module	Displacement encoder		→ Page/ Internet
	DDLI/DGCI	DGPI	DNCI, DDPC	DSMI	MLO-LWG/-TLF	MME-MTS	
End-position controller CPX-CMPX	■	■	■	■	■	■	cmpx
Prop. directional control valve VPWP	■	■	■	■	■	■	vpwp
Sensor interface CASM-S-D2-R3	-	-	-	■	■	-	casm
Sensor interface CASM-S-D3-R7	-	-	■	-	-	-	casm
Connecting cable KVI-CP-3-...	■	■	■	■	■	■	kvi
Connecting cable NEBC-P1W4-...	-	-	-	■	■ / -	-	nebc
Connecting cable NEBC-A1W3-...	-	-	-	-	- / ■	-	nebc
Connecting cable NEBP-M16W6-...	-	■	-	-	-	■	nebp

System components for pneumatic positioning systems with axis controller CPX-CMAX							
	Linear drive		Standard cylinder	Swivel module	Displacement encoder		→ Page/ Internet
	DDLI/DGCI	DGPI	DNCI, DDPC	DSMI	MLO-LWG/-TLF	MME-MTS	
Axis controller CPX-CMAX	■	■	■	■	■	■	cmax
Prop. directional control valve VPWP	■	■	■	■	■	■	vpwp
Sensor interface CASM-S-D2-R3	-	-	-	■	■	-	casm
Sensor interface CASM-S-D3-R7	-	-	■	-	-	-	casm
Connecting cable KVI-CP-3-...	■	■	■	■	■	■	kvi
Connecting cable NEBC-P1W4-...	-	-	-	■	■ / -	-	nebc
Connecting cable NEBC-A1W3-...	-	-	-	-	- / ■	-	nebc
Connecting cable NEBP-M16W6-...	-	■	-	-	-	■	nebp

System components for measuring cylinders with measuring module CPX-CMIX							
	Linear drive		Standard cylinder	Swivel module	Displacement encoder		→ Page/ Internet
	DDLI/DGCI	DGPI	DNCI, DDPC	DSMI	MLO-LWG/-TLF	MME-MTS	
Measuring module CPX-CMIX-M1-1	■	■	■	■	■	■	cmix
Sensor interface CASM-S-D2-R3	-	-	-	■	■	-	casm
Sensor interface CASM-S-D3-R7	-	-	■	-	-	-	casm
Connecting cable KVI-CP-3-...	(■) <sup>1)</sup>	(■) <sup>1)</sup>	■	■	■	(■)	kvi
Connecting cable NEBC-P1W4-...	-	-	-	■	■ / -	-	nebc
Connecting cable NEBC-A1W3-...	-	-	-	-	- / ■	-	nebc
Connecting cable NEBP-M16W6-...	-	■	-	-	-	■	nebp

1) As an extension



# Cylinders with displacement encoder

Overview

## Individual components for positioning

With axis controller SPC200

→ Internet: [spc200](#)

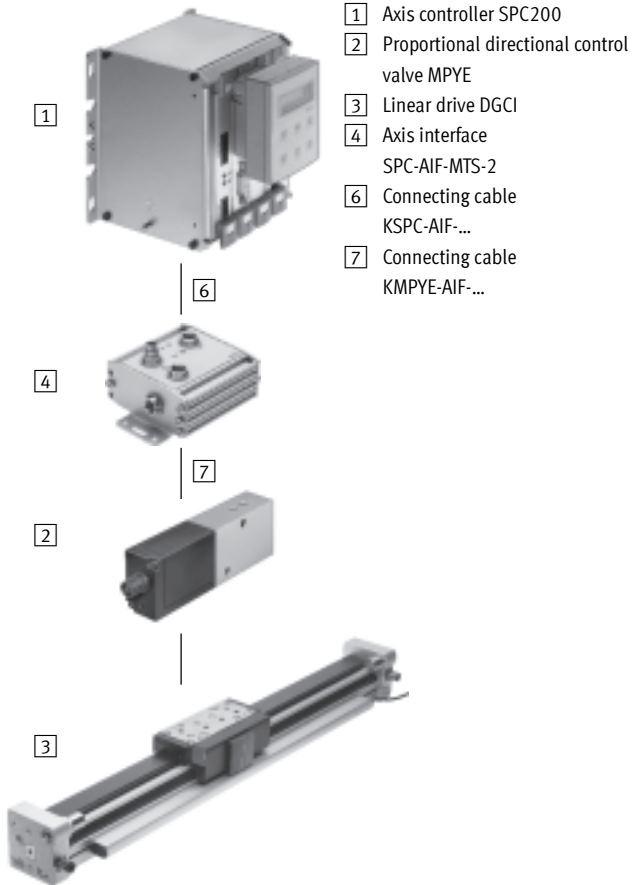

- 1 Axis controller SPC200
- 2 Proportional directional control valve MPYE
- 3 Linear drive DGCI
- 4 Axis interface SPC-AIF-MTS-2
- 6 Connecting cable KSPC-AIF-...
- 7 Connecting cable KMPYE-AIF-...

## With end-position controller SPC11

→ Internet: [spc11](#)

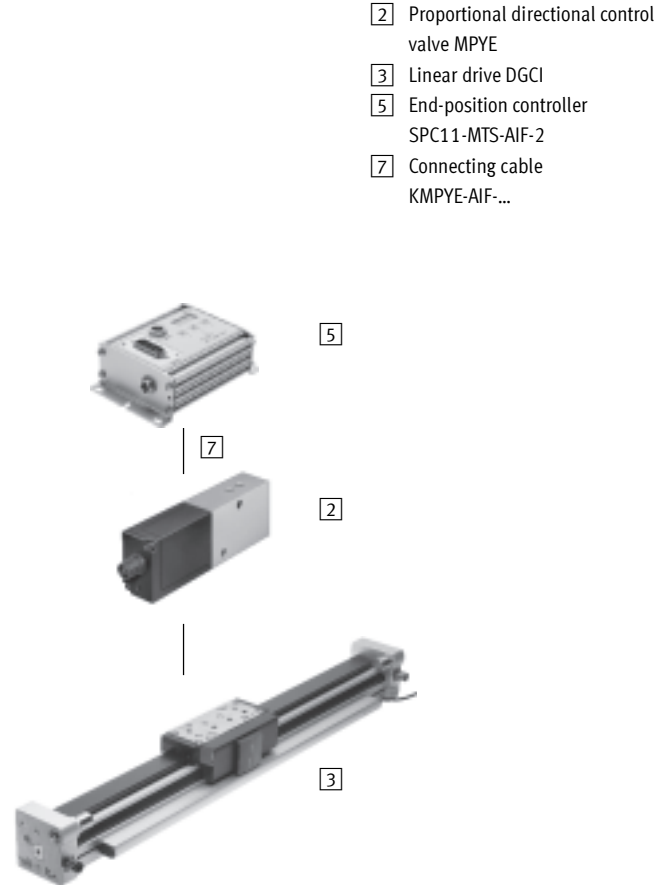

- 2 Proportional directional control valve MPYE
- 3 Linear drive DGCI
- 5 End-position controller SPC11-MTS-AIF-2
- 7 Connecting cable KMPYE-AIF-...

## Individual components for use as a measuring cylinder

With measuring module CPX-CMIX

→ Internet: [cmix](#)

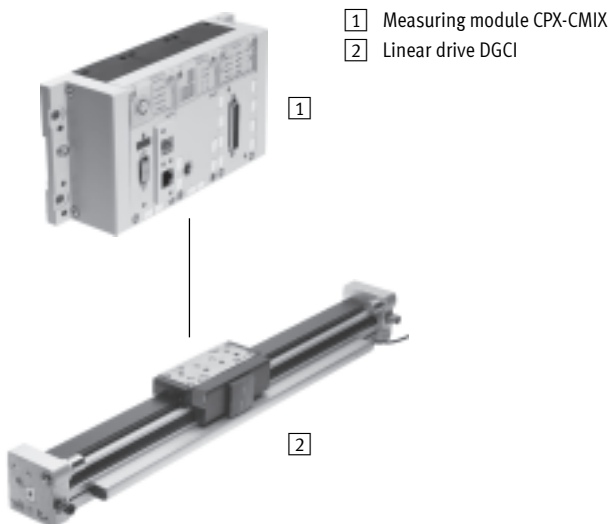

- 1 Measuring module CPX-CMIX
- 2 Linear drive DGCI

# Linear drives DGCI, with displacement encoder

Key features

FESTO

## At a glance

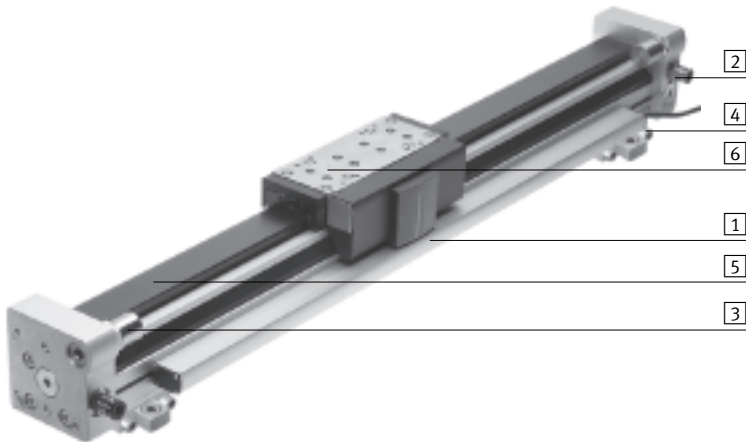

### 1 Displacement encoder → 18

- High degree of protection IP67
- Non-contacting
- Measures absolute values

### 2 Supply ports → 35

- Optionally on two sides (on the end face or at the front)
- Optionally with different coloured push-in fittings for simple and error-free tubing connections

### 3 End stops → 24

- Metal fixed stop
- Shock absorber, precisely adjustable

### 4 Profile mounting → 22

- Profile mountings remain on the base plate after the drive is dismantled. This saves time during assembly and removal

### 5 Recirculating ball bearing guide → 16

- Piston  $\varnothing$  18 ... 63 mm
- Stroke lengths 100 ... 2,000 mm
- Guide backlash = 0 mm
- For medium and large loads
- Precision mounting interface with stainless steel slide
- Operating behaviour under torque load = very good

### 6 Recirculating ball bearing guide with protected guide → 16

- Piston  $\varnothing$  18 ... 40 mm
- Stroke lengths 100 ... 2,000 mm
- Guide backlash = 0 mm
- The protected guide cleans the guide rail and protects the recirculating ball bearing guide by means of an additional wiper seal and lubrication unit

### – Passive guide axis DGC-FA → dgc-fa

- Without drive
- Piston  $\varnothing$  8 ... 63 mm
- Stroke lengths 1 ... 5,000 mm
- Guide backlash = 0 mm
- Precision guide, suitable for DGCI. Can be used as a machine component or as a twin guide with DGCI

### – Passive guide axis with protected guide DGC-FA-GP → dgc-fa

- Without drive
- Piston  $\varnothing$  18 ... 63 mm
- Stroke lengths 1 ... 5,000 mm
- Guide backlash = 0 mm
- The protected guide cleans the guide rail and protects the recirculating ball bearing guide by means of an additional wiper seal and lubrication unit

## Linear drives DGCI, with displacement encoder

Key features

### Options

#### Central lubrication

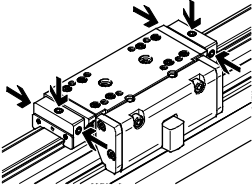

The lubrication adapter enables the guide of the linear drive DGCI to be permanently lubricated in applications in humid or wet ambient conditions using semi or fully automatic relubrication devices. The adapters are suitable for oils and greases.

- For piston  $\varnothing$  25, 32, 40, 63 mm
- Connections:
  - On both sides of the slide
  - In three places (front, top, rear) on each side

Technical data → 23

#### Clamping unit – 1H-PN

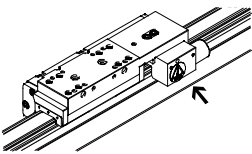

- 1-channel design, for holding loads
- Reliable holding is guaranteed since the forces act directly on the slide
- A limited number of emergency braking operations are permissible with the size 40
- No stroke reduction; the drive is extended by the length of the clamping unit

- For piston  $\varnothing$  25, 32, 40 mm

Technical data → 21

#### Additional slide – KL/KR

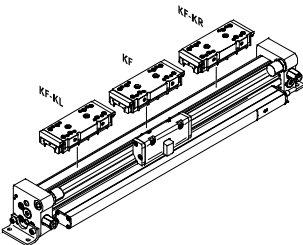

- Additional slide, either to the right or left of the main slide
- To increase the torques

- For piston  $\varnothing$  18, 25, 32, 40, 63 mm

Technical data → 34

#### NSF-H1 lubricant for the food industry

The linear drive is of limited suitability for the food industry. More information on suitability for use in the food industry → Manufacturer's declaration.

Not approved for use in the food industry:

- DGCI-...-GP (protected version)
- DGCI-... with integrated shock absorbers

# Linear drives DGCI, with displacement encoder

Peripherals overview

-  - Note  
Drive must not be operated without end stops or shock absorbers.

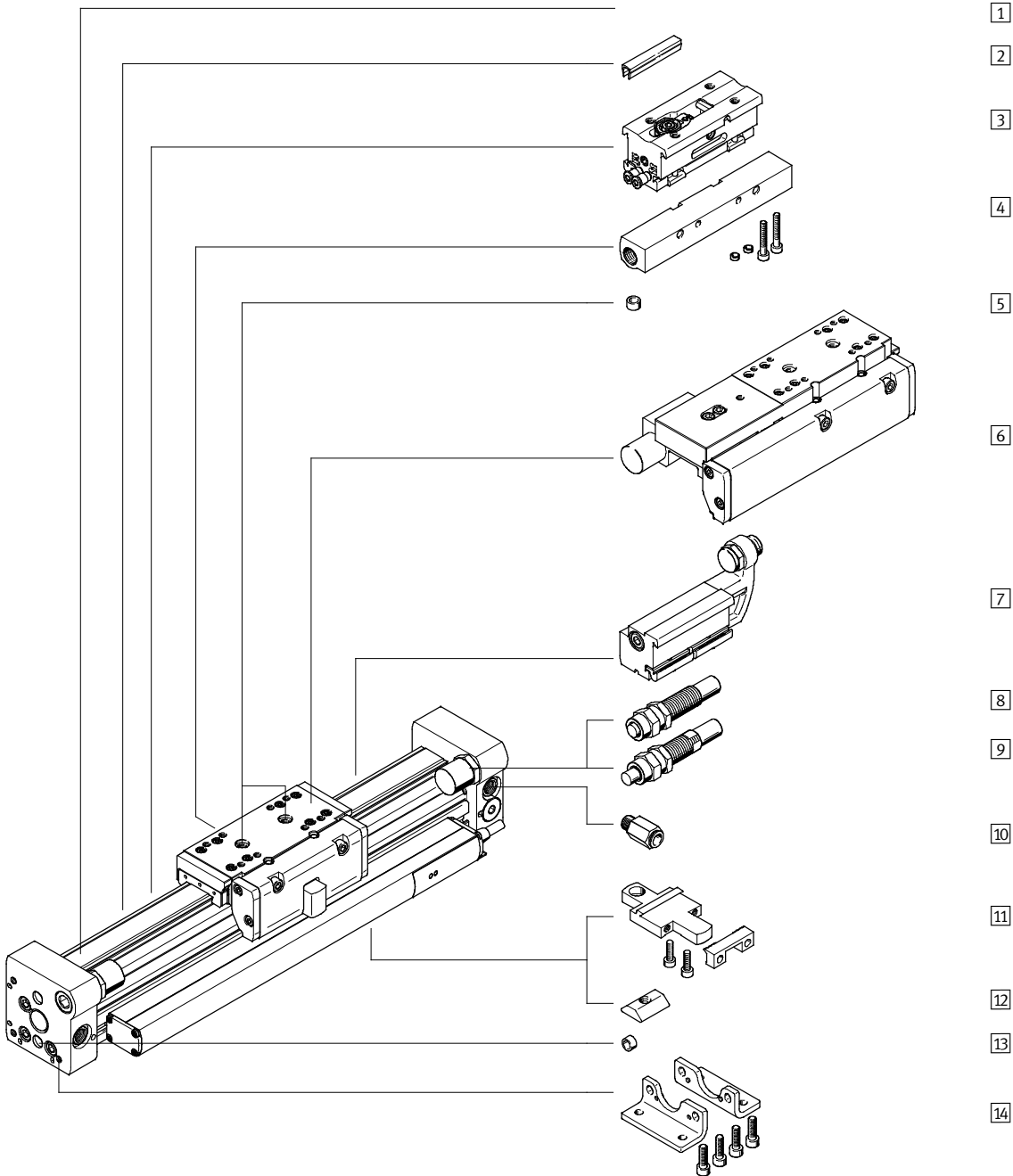

# Linear drives DGCI, with displacement encoder

Peripherals overview

Variants and accessories			
Type	For piston $\varnothing$	Brief description	→ Page/Internet
1 Linear drive DGCI-KF	18 ... 63	Linear drive without accessories, with recirculating ball bearing guide.	16
2 Slot cover L	18 ... 63	For protecting against the ingress of dirt and securing proximity sensor cables.	44
3 Intermediate position module DADM-DGC	25, 32	Facilitates intermediate positions with metal fixed stop. The module can be attached.	42
4 Shock absorber retainer DADP-DGC	18 ... 63	For variable end-position adjustment in combination with the stop KYC.	40
5 Centring pin/sleeve <sup>1)</sup> ZBS/ZBH	18 ... 63	For centring loads and attachments on the slide.	44
6 Clamping unit 1H-PN	25, 32, 40	For holding loads.	21
7 Stop KYC	18 ... 63	For variable end-position adjustment in combination with the shock absorber retainer DADP-DGC.	40
8 Shock absorber YSR	18 ... 63	Self-adjusting hydraulic shock absorber with spring return and linear cushioning characteristics.	36
9 Shock absorber YSRW	18 ... 63	Self-adjusting hydraulic shock absorber with spring return and progressive cushioning characteristics.	36
10 Push-in fitting QS	18 ... 63	For connecting compressed air tubing with standard O.D.	35
11 Profile mounting M	18 ... 63	Simple and precise mounting option via dovetail connection.	39
12 Slot nut B	25 ... 63	For mounting attachments.	44
13 Centring pin/sleeve <sup>1)</sup> ZBS/ZBH	18 ... 63	For centring the drive without foot mountings (user-specific).	44
14 Foot mounting F	18 ... 63	For mounting on the end cap.	38
- Proportional directional control valve VPWP	18 ... 63	Regulates the compressed air and therefore the position of the slide.	44

1) Included in the scope of delivery of the drive

 - Note  
Allocation table of drives and associated proportional directional control valves → 44



# Linear drives DGCI, with displacement encoder

Type codes



	ZUB	F		2B	
<b>Accessories</b>					
ZUB	Accessories enclosed separately				
<b>Type of mounting</b>					
F	Foot mounting				
M	Profile mounting				
<b>Slot cover</b>					
...L	For sensor slot				
<b>Slot nut</b>					
...B	For mounting slot				
<b>Operating instructions</b>					
0	Express waiver – no operating instructions to be included				

# Linear drives DGCI, with displacement encoder

FESTO

Technical data

Function

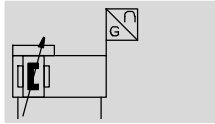

- - Diameter  
18 ... 63 mm
- - Stroke length  
100 ... 2,000 mm

General technical data					
Piston Ø	18	25	32	40	63
Design	Rodless linear drive with displacement encoder				
Mode of operation	Double-acting				
Moment compensator principle	Slotted cylinder, mechanically coupled				
Guide	External recirculating ball bearing guide				
Mounting position	Any				
Type of mounting	Profile mounting				
	Foot mounting				
	Direct mounting				
Cushioning → 21	Via metal fixed stop				
	Via shock absorber, self-adjusting at both ends				
Position sensing	Via attached displacement encoder				
Measuring principle (displacement encoder)	Digital, magnetostrictive, non-contacting and absolute measurement				
Pneumatic connection <sup>1)</sup>	M5	G1/8	G1/4	G3/8	
Stroke <sup>2)</sup>	[mm] 100; 160; 225; 300; 360; 450; 500; 600; 750; 850; 1,000; 1,250; 1,500; 1,750; 2,000				
Protected version	Optional				-
Max. speed <sup>3)</sup>	[m/s] 5				
Stroke tolerance	[mm] 0 ... 2.5				

- 1) Recommended push-in fittings → 44  
With pre-assembled push-in fittings, the tubing diameters apply → 22
- 2) Note stroke reduction in combination with CPX-CMAX, SPC200
- 3) Only applies to applications with end-position controller CPX-CMPX, SPC11 and axis controller CPX-CMAX, SPC200. Otherwise a maximum speed of 3 m/s is permitted.

Operating and environmental conditions					
Piston Ø	18	25	32	40	63
Operating pressure	[bar] 2 ... 8			1.5 ... 8	
Operating pressure <sup>1)</sup>	[bar] 4 ... 8				
Operating medium <sup>2)</sup>	Compressed air according to ISO 8573-1:2010 [6:4:4]				
Note about the operating/pilot medium	Lubricated operation not possible Pressure dew point 10 °C below ambient/medium temperature				
Ambient temperature	[°C] -10 ... +60				
Vibration resistance to DIN/IEC 68, Part 2-6	At 10 ... 58 Hz: 0.15 mm				
	At 58 ... 150 Hz: 2G				
Continuous shock resistance to DIN/IEC 68, Part 2-27	Half sine 15 g, 11 ms				
CE mark (see declaration of conformity) <sup>3)</sup>	To EU EMC Directive				
Certification	C-Tick				
Corrosion resistance class CRC <sup>4)</sup>	1				
ATEX	Specified types → www.festo.com				

- 1) Only applies to applications with end-position controller CPX-CMPX, SPC11 and axis controller CPX-CMAX, SPC200
- 2) The proportional directional control valve VPWP, MPYE requires these characteristic values
- 3) For information about the applicability of the component see the manufacturer's EC declaration of conformity at: www.festo.com → Support → User documentation.  
If the component is subject to restrictions on usage in residential, office or commercial environments or small businesses, further measures to reduce the emitted interference may be necessary.
- 4) Corrosion resistance class 1 according to Festo standard 940 070  
Components subject to low corrosion stress. Transport and storage protection. Parts that do not have primarily decorative surface requirements, e.g. in internal areas that are not visible or behind covers.



# Linear drives DGCI, with displacement encoder

Technical data

Forces [N] and impact energy [Nm]					
Piston $\varnothing$	18	25	32	40	63
Theoretical force at 6 bar	153	295	483	754	1,870
Impact energy in the end positions					
With fixed stop	0.4	0.5	0.7	0.7	0.7
With shock absorber YSR/YSRW	→ 21				

Positioning characteristics with axis controller CPX-CMAX, SPC200					
Piston $\varnothing$	18	25	32	40	63
Mounting position	Any				
Resolution [mm]	0.01				
Repetition accuracy [mm]	→ 19				
Minimum load, horizontal <sup>1)</sup> [kg]	1	2	3	5	12
Maximum load, horizontal <sup>1)</sup> [kg]	15	30	50	75	180
Minimum load, vertical <sup>1)</sup> [kg]	1	2	3	5	12
Maximum load, vertical <sup>1)</sup> [kg]	5	10	15	25	60
Minimum travel speed [m/s]	0.05				
Maximum travel speed [m/s]	5				
Typical positioning time, long stroke <sup>2)</sup> [s]	0.75/1.15	0.65/1.00	0.65/1.05	0.70/1.05	1.05/1.20
Typical positioning time, short stroke <sup>3)</sup> [s]	0.38/0.65	0.38/0.60	0.38/0.60	0.38/0.60	0.65/0.65
Minimum positioning stroke <sup>4)</sup> [%]	≤ 3				
Stroke reduction <sup>5)</sup> [mm]	20	25	25	35	35
Recommended proportional directional control valve					
For CPX-CMAX	→ 44				
For SPC200	→ 46				

- 1) Load = effective load + mass of all moving parts on the drive
- 2) At 6 bar, horizontal mounting position, DGCI-XX-1000, 800 mm travel at min./max. load
- 3) At 6 bar, horizontal mounting position, DGCI-XX-1000, 100 mm travel at min./max. load
- 4) Referred to the maximum stroke of the drive, but never more than 20 mm
- 5) The stroke reduction is to be maintained on each side of the drive, the max. positionable stroke is therefore: stroke – 2x stroke reduction

Force control characteristics with axis controller CPX-CMAX					
Piston $\varnothing$	18	25	32	40	63
Mounting position	Any				
Maximum controllable force <sup>1)</sup> [N]	138	266	435	679	1,683
Typical friction forces <sup>2)</sup> [N]	40	60	40	50	70
Repetition accuracy of pressure control <sup>3)4)</sup> [%]	< ±2				

- 1) Advancing/retracting at 6 bar
- 2) These values can fluctuate greatly from cylinder to cylinder and are not guaranteed. These friction forces must also be taken into consideration when using an external guide or when the cylinder is moving other components subject to friction
- 3) This value defines the repetition accuracy with which the internal differential pressure in the cylinder is controlled and refers to the maximum controllable force (the internal differential pressure corresponds to the prescribed force setpoint value)
- 4) The effective force at the workpiece and its accuracy depends largely on the friction in the system as well as the repetition accuracy of the internal control system. Note that friction forces always work against the direction of movement of the piston. The following formula can be used as a rule of thumb for the force F at the workpiece:  

$$F = F_{\text{setpoint}} \pm F_{\text{friction forces}} \pm \text{repetition accuracy of pressure control}$$

# Linear drives DGCI, with displacement encoder

Technical data

Positioning characteristics with Soft Stop end-position controller CPX-CMPX, SPC11						
Piston $\varnothing$		18	25	32	40	63
Mounting position		Any				
Repetition accuracy <sup>1)</sup>	[mm]	±2				
Minimum load, horizontal <sup>2)</sup>	[kg]	1	2	3	5	12
Maximum load, horizontal <sup>2)</sup>	[kg]	15	30	50	75	180
Minimum load, vertical <sup>2)</sup>	[kg]	1	2	3	5	12
Maximum load, vertical <sup>2)</sup>	[kg]	5	10	15	25	60
Travel time	[s]	→ SoftStop sizing software: → <a href="http://www.festo.com">www.festo.com</a>				
Recommended proportional directional control valve						
For CPX-CMPX		→ 45				
For SPC11		→ 46				

1) One intermediate position. The accuracy in the end positions depends solely on the design of the end stops

2) Load = effective load + mass of all moving parts on the drive

Electrical data – Displacement encoder	
Output signal	Digital
Linearity error <sup>1)</sup>	[%] < ±0.02, min. ±50 µm
Maximum travel speed	[m/s] 5
Protection class	IP67
CE marking (see declaration of conformity)	To EU EMC Directive <sup>2)</sup>
Power supply	[V DC] 24 (±25%)
Current consumption	[mA] Typically 100
Maximum temperature coefficient	[ppm/°K] 15
Electrical connection	Cable with 5-pin plug, round type M9
Cable length	[m] 1.5
Cable quality	Suitable for use with energy chains

1) Always refers to max. stroke

2) For information about the applicability of the component see the manufacturer's EC declaration of conformity at: [www.festo.com](http://www.festo.com) → Support → User documentation.  
If the component is subject to restrictions on usage in residential, office or commercial environments or small businesses, further measures to reduce the emitted interference may be necessary.

## Pin allocation of plug

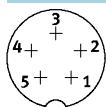

Pin	Function	Pin	Function
1	24 V	4	CAN_H
2	-	5	CAN_L
3	0 V	-	Screened

# Linear drives DGCI, with displacement encoder

Technical data

Weight [g]					
Piston $\varnothing$	18	25	32	40	63
DGCI-...					
Basic weight with 0 mm stroke	1,200	2,400	3,100	7,300	22,500
Additional weight per 10 mm stroke	38	56	81	124	243
Moving load	360	770	1,170	2,360	8,200
Moving load on additional slide	300	650	950	2,000	5,600
DGCI-...-1H-PN – With clamping unit					
Basic weight with 0 mm stroke	-	3,436	4,582	12,386	-
Additional weight per 10 mm stroke	-	0.056	0.081	0.124	-
Moving load	-	1,430	2,084	5,519	-

## Materials

Sectional view

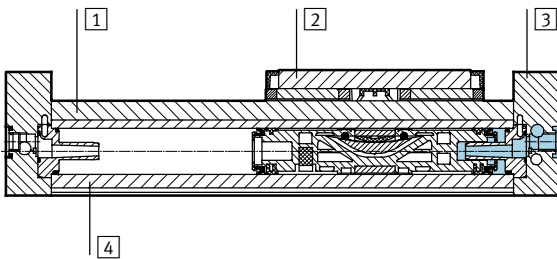

Linear drives		
1	Guide rail	High-alloy steel
2	Slide	High-alloy steel
3	End cap	Anodised aluminium
4	Cylinder profile, housing	Anodised aluminium
-	Seals, sealing band	Polyurethane
-	Guide band, dirt wiper, reversing roller	Polyacetal
-	Cover	Polyacetal, polyamide, powder-coated aluminium
-	Displacement encoder	Anodised aluminium, glass-fibre reinforced polyphthalamide
-	Cable	Polyurethane
-	Note on materials	Free of copper and PTFE

## Repetition accuracy x as a function of stroke l

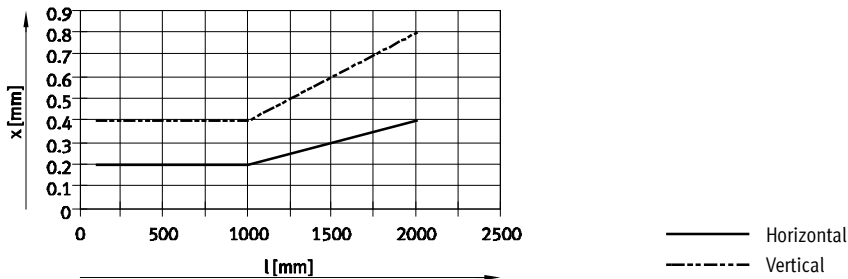

# Linear drives DGCI, with displacement encoder

Technical data

## Characteristic load values for linear drive with recirculating ball bearing guide and guide

The indicated forces and torques refer to the slide surface and the centre of the slide.

These values must not be exceeded during dynamic operation. Special attention must be paid to the deceleration phase.

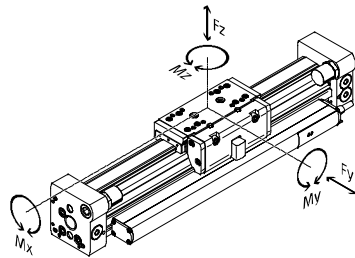

GP – Protected guide

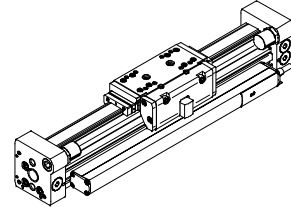

If the drive is simultaneously subjected to several of the forces and torques listed below, the following equation must be satisfied in addition to the indicated maximum loads:

$$\frac{F_y}{F_{y_{max.}}} + \frac{F_z}{F_{z_{max.}}} + \frac{M_x}{M_{x_{max.}}} + \frac{M_y}{M_{y_{max.}}} + \frac{M_z}{M_{z_{max.}}} \leq 1$$

### Permissible forces and torques

Piston Ø	18	25	32	40	63
F <sub>y<sub>max.</sub></sub> [N]	1,850	3,050	3,310	6,890	15,200
F <sub>z<sub>max.</sub></sub> [N]	1,850	3,050	3,310	6,890	15,200
M <sub>x<sub>max.</sub></sub> [Nm]	16	36	54	144	529
M <sub>y<sub>max.</sub></sub> [Nm]	51	97	150	380	1,157
M <sub>z<sub>max.</sub></sub> [Nm]	51	97	150	380	1,157

### Note

To avoid distortion in the slide, the bearing surfaces of the attachments must maintain a flatness of 0.01 mm.

## Linear drives DGCI, with displacement encoder

**FESTO**

Technical data

### Maximum permissible piston speed with shock absorber $v$ as a function of effective load $m$

Piston  $\varnothing$  18 ... 63 with YSR cushioning

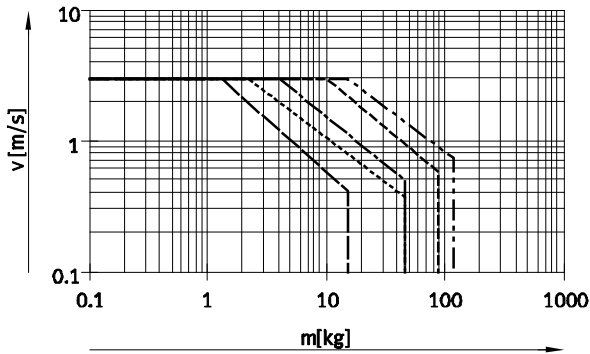

Piston  $\varnothing$  18 ... 63 with YSRW cushioning

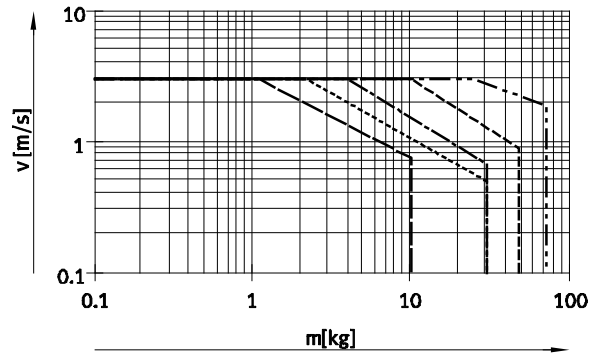

- - - -  $\varnothing$  18      - - - -  $\varnothing$  40  
 - - - -  $\varnothing$  25      - - - -  $\varnothing$  63  
 - - - -  $\varnothing$  32

 Note

This data represents the maximum values that can be achieved. In practice, values fluctuate relative to the size of the effective load.

Technical data – Clamping unit		Dimensions → 32		
Size		25	32	40
Pneumatic connection		M5	M5	M5
Clamping type		Clamping via spring force, released via compressed air		
Static holding force	[N]	320	500	1,200
Max. number of emergency braking operations <sup>1)</sup> at reference energy	[Nm]	–	–	750 35
Number of clamping operations under nominal load	[million switching cycles]	0.45	0.55	0.05

1) Emergency braking refers to braking the effective load if the drive axis loses power.

Operating and environmental conditions – Clamping unit	
Operating medium	Compressed air according to ISO 8573-1:2010 [7:4:4]
Operating pressure	
Clamping unit opened	[bar] 4.5 ... 8
Clamping unit closed	[bar] Pressureless
Ambient temperature	[°C] –10 ... +60

 Note

No stroke reduction in combination with the clamping unit; the drive is extended by the length of the clamping unit.

# Linear drives DGCI, with displacement encoder

Technical data

## Number of profile mountings MUC as a function of overall length

Excessive distances between the profile mountings can reduce the positioning accuracy. The following table shows the required minimum number of profile and foot mountings.

Stroke [mm]	Number of mounting attachments		
	Order code M		Order code F
	Profile mounting	Foot mounting	+ profile mounting
100 ... 400	2	2	0
401 ... 600	2	2	1
601 ... 1,200	3	2	1
1,201 ... 1,400	3	2	2
1,401 ... 2,000	4	2	2

Tubing diameter with pre-assembled push-in fittings					
Size	Stroke [mm]	Ø in [mm]			
		6	8	10	12
DGCI-18	100 ... 2,000	■	-	-	-
DGCI-25	100 ... 160	■	-	-	-
	225 ... 2,000	-	■	-	-
DGCI-32	100 ... 2,000	-	■	-	-
DGCI-40	100 ... 750	-	■	-	-
	850 ... 2,000	-	-	■	-
DGCI-63	100 ... 300	-	■	-	-
	360 ... 750	-	-	■	-
	850 ... 2,000	-	-	-	■

# Linear drives DGCI, with displacement encoder

Technical data

## Central lubrication

The lubrication adapter enables the guide of the linear drive DGCI to be permanently lubricated in applications in humid or wet ambient conditions using semi or fully automatic relubrication devices.

- For piston  $\varnothing$  25, 32, 40, 63
- The modules are suitable for oils and greases
- The dimensions of the linear drive DGCI are the same with and without central lubrication modules
- Both lubrication adapters must be connected
- There are three connection options on each side
- Can be used in combination with:
  - Standard slide GK
  - Additional slide KL, KR
- Cannot be used in combination with:
  - Protected recirculating ball bearing guide GP

Slide dimensions

→ 30

Order code C in the modular product system → 37

## Connection options

Only the connection at the rear or on the top can be used in combination with shock absorbers in the end caps.

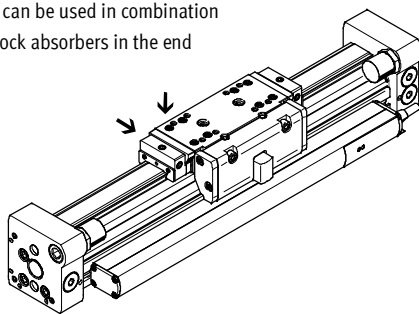

Only the connection on the front or top can be used in combination with shock absorber retainer DADP.

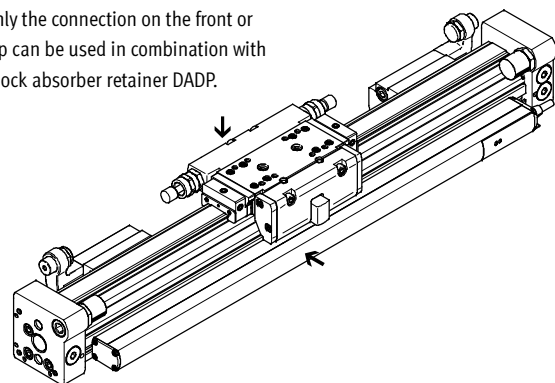

## Connection option for customer design

The drawing opposite shows the connection option on the top lubrication interface using a customer design.

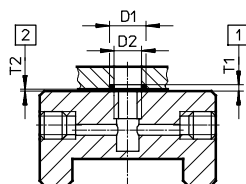

- D1  $8^{+0.2}$  mm
- D2 6 mm
- T1  $0.6_{-0.05}$  mm
- T2  $0.1^{+0.2}$  mm
- O-ring  $\varnothing$  6x1 mm (DIN3771)

- 1 Slot depth for O-ring
- 2 Required air gap

Additional dimensions → 30

## Structure of a central lubrication system

A central lubrication system requires various additional components. The illustration shows different options (using a hand pump, pneumatic container pump or electric container pump) required as a minimum for designing a central lubrication system. Festo does not sell these additional components; however, they can be obtained from the following companies:

- Lincoln
- Bielomatik
- SKF (Vogel)

Festo recommends these companies because they can supply all the necessary components.

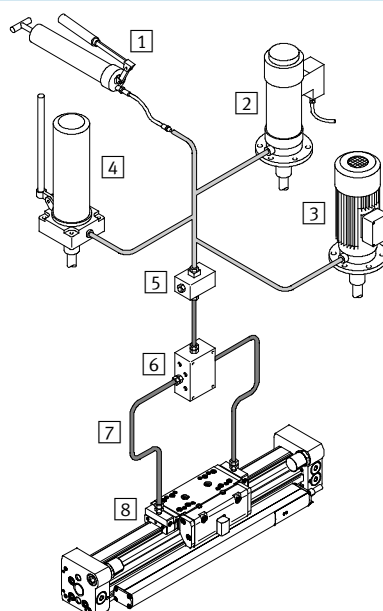

- 1 Hand pump
- 2 Pneumatic container pump
- 3 Electric container pump
- 4 Manually operated container pump
- 5 Nipple block
- 6 Distributor block
- 7 Tubing or piping
- 8 Fittings

# Linear drives DGCI, with displacement encoder

Technical data

FESTO

## Dimensions

Download CAD data → [www.festo.com](http://www.festo.com)

Ø 18 ... 63

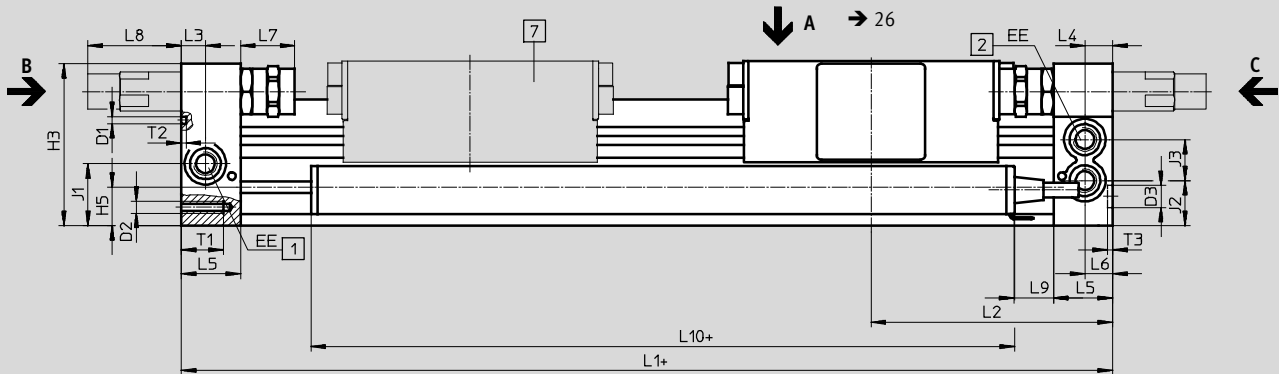

View C

Ø 18 ... 40

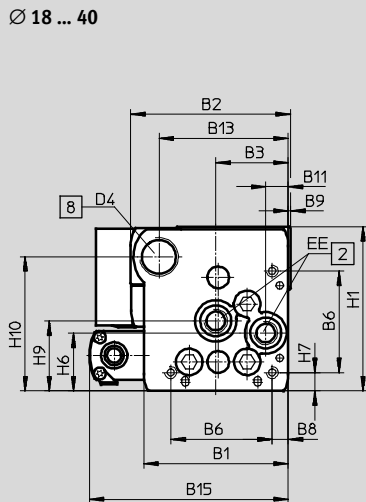

Ø 63

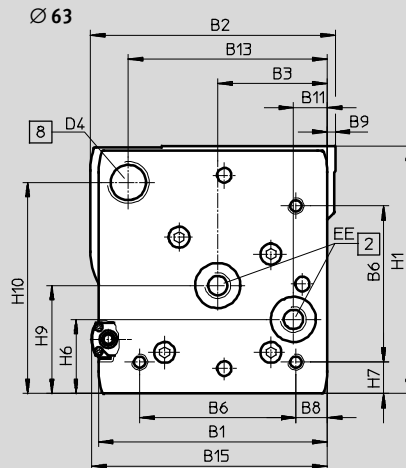

View B

Ø 18

Ø 25 ... 40

Ø 18 ... 40

Ø 63

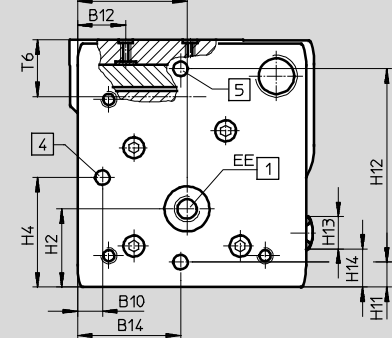
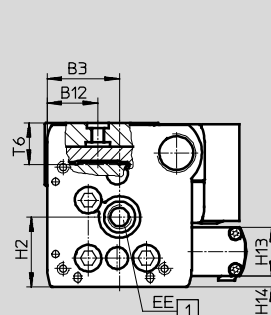
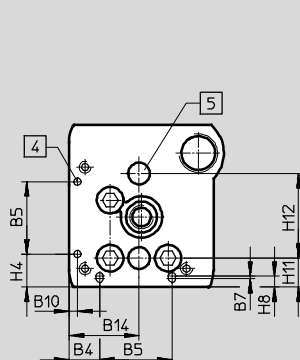
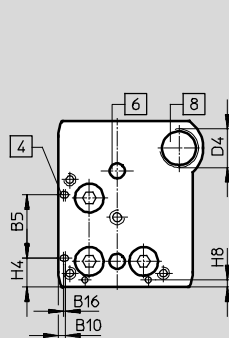

+ plus stroke length

1 Supply port options on 2 sides  
(on the end face or at the front)

2 Supply port options on 2 sides,  
for supply port at one end (on  
the end face or at the front)

4 Mounting hole for foot  
mounting HPC

5 Hole for centring pin ZBS

6 Hole for centring sleeve ZBH

7 Additional slide  
8 Thread for end stop



# Linear drives DGCI, with displacement encoder

Technical data

∅ [mm]	B1	B2	B3	B4 ±0.1	B5 ±0.05	B6	B7	B8 ±0.1	B9	B10	B11	B12
18	44.5	49.9	19.5	8.8	21	31	-	3.8	1	2.4	5.5	15.5
25	59.8	66	30	12.65	30	42	1	6.65	1	3.5	9.3	21
32	73	79	38.5	5.7	63.1	57.5	-	8.5	1.5	14	14.9	18
40	91	98.5	45	17.2	55	65	-	12.2	2	8	16.5	24.8
63	142	149	68	-	-	97	-	19.5	5	15.5	21	30

∅ [mm]	B13	B14 ±0.05	B15	B16	D1 ∅	D2	D3 ∅ H7	D4	EE	H1	H2	H3
18	39	19.5	68.3	0.8	2±0.05	M4	5	M12x1	M5	56.3	23.1	55
25	53	29	82.4	-	3±0.05	M5	9	M16x1	G1/8	68	29	67
32	65	38.5	97.8	-	3±0.05	M6	9	M16x1	G1/8	78.5	30	77
40	80.5	45	110.3	-	4±0.05	M6	9	M22x1.5	G1/4	99.5	41.5	97.5
63	123.5	68	146.3	-	9 <sup>H7</sup>	M10	9	M26x1.5	G3/8	153.5	48.5	151

∅ [mm]	H4 ±0.1	H5	H6	H7	H8	H9	H10	H11	H12 ±0.05	H13	H14	J1	J2	J3
18	9.6	13.4	20	4.6	2.4	25.2	46	8.5±0.15	30	20	2.3	20	16.5	11
25	13.65	15.8	24	7.65	4.5	29	55.5	12±0.15	35	20	4.7	26.1	18.6	17
32	5.7	17	27.7	8.5	14	35.2	63.8	11.45±0.15	50	20	5.9	30	22	18.5
40	17.2	25	36.5	12.2	8	44	81.5	15±0.15	60	20	13.9	35	26	26
63	68	34.8	46	19.5	-	67	131	15.5±0.2	120	20	23.7	41.5	39.5	31.5

∅ [mm]	L1			L2			L3	L4	L5	L6	L7		
	KF	KF-GP	1H-PN	KF	KF-GP	1H-PN					KF	KF-GP	KF-YSR(W)
18	150	157	-	74.5	78	-	5.7	5.8	15	5.5	14.5 ... 16.5	18 ... 20	14.5 ... 34.5
25	200	205	271	100	102.5	100	10.5	10.6	24.5	10.6	22.5 ... 26.5	25 ... 29	22.5 ... 47.5
32	250	250	320.5	124.8	124.8	124.8	14.5	14.5	30.5	14.5	27.3 ... 32.3	27.3 ... 32.3	27.3 ... 52.3
40	300	312	458	150	156	150	14.6	14.6	33.5	14.6	31 ... 36	37 ... 42	31 ... 56
63	400	-	-	200	-	-	20	20	44	20	41 ... 46	-	41 ... 76

∅ [mm]	L8		L9		L10 max.	T1	T2	T3 +0.2	T6	Stroke tolerance
	YSR	YSRW	KF ±0.2	KF-GP ±0.2						
18	29.9	32.6	-	3.5	119	9	2	3.1	15	0 ... 2.5
25	35.6	38.6	16.5	19	119	17.5	2	2.1	17.3	
32	19.5	28	35.3	35.3	119	15	2	2.1	20	
40	38.5	43.5	17	23	119	20	2	2.1	25.7	
63	38.3	48.3	97	-	119	27.5	2.1 <sup>+0.2</sup>	2.1	36.1	

 Note  
 For reasons of functional safety of the displacement encoder and stability of the linear drive DGCI, the distance L7 must not fall below the values in the table.

# Linear drives DGCI, with displacement encoder

Technical data

FESTO

## Dimensions

Download CAD data → [www.festo.com](http://www.festo.com)

Slide

Ø 18

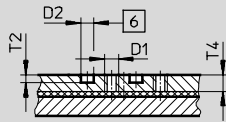

View A

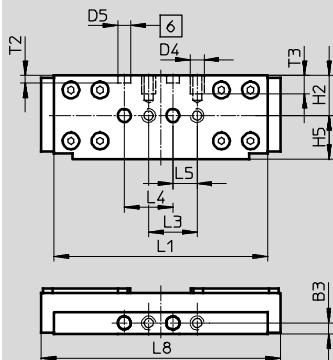

Ø 25

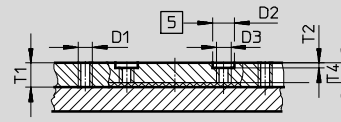

View A

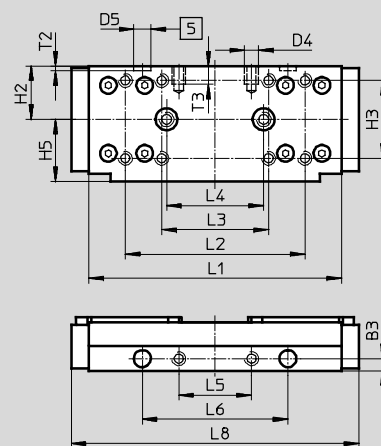

Ø 32

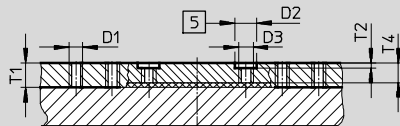

View A

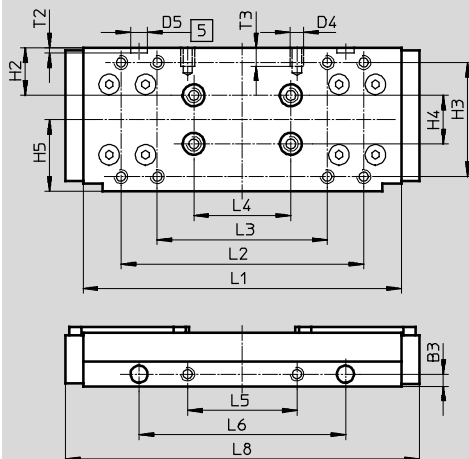

Ø 40

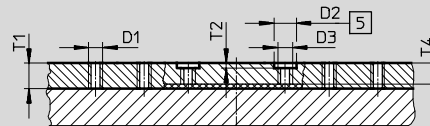

View A

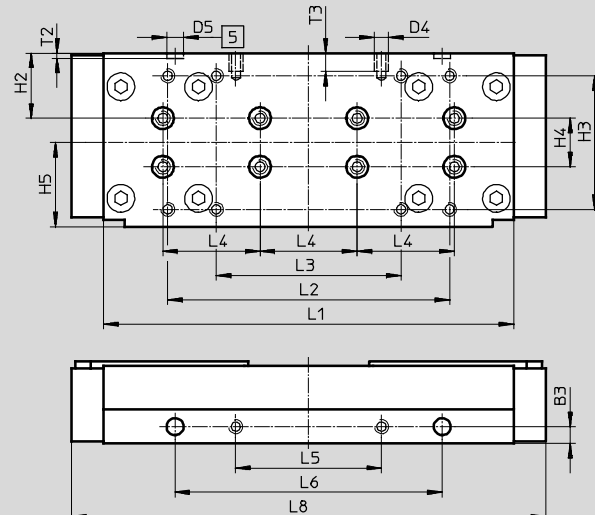

5 Hole for centring sleeve ZBH

6 Hole for centring pin ZBS

# Linear drives DGCI, with displacement encoder

Technical data

FESTO

## Dimensions

Download CAD data → [www.festo.com](http://www.festo.com)

Slide

∅ 63

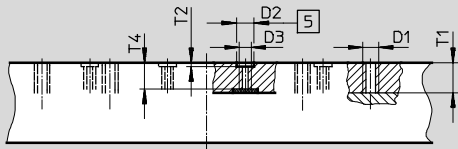

View A

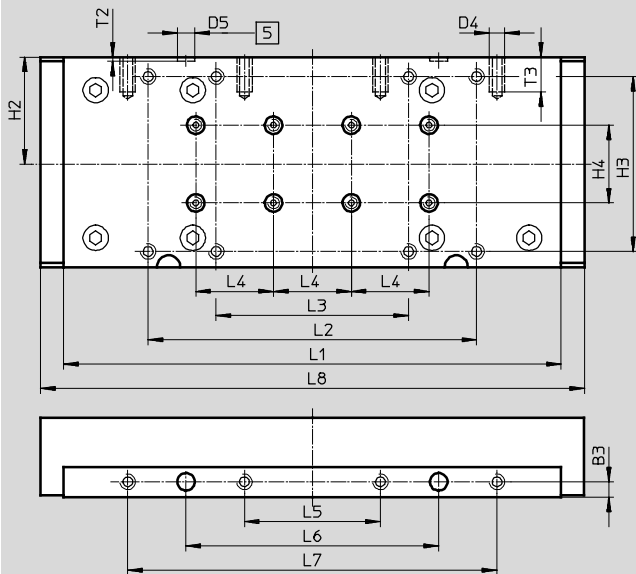

- 5 Hole for centring sleeve ZBH
- 6 Hole for centring pin ZBS

∅	B3	D1	D2	D3	D4	D5	H2	H3	H4	H5	L1
[mm]	±0.05		∅ H7			∅ H7			±0.03	±0.1	
18	4.5	M5	5	-	M5	5	16.5	-	-	18	88±0.1
25	5	M5	9	M6	M5	7	22	32±0.2	-	25.5	104±0.2
32	5	M5	9	M6	M5	7	19.5	47±0.2	20	29.5	131±0.2
40	7	M5	9	M6	M6	7	26.8	55±0.2	20	34.7	169±0.2
63	8	M8	9	M6	M8	9	55	90±0.3	40	-	256±0.1

∅	L2	L3	L4	L5	L6	L7	L8	T1	T2	T3	T4
[mm]	±0.2		±0.03	±0.1	±0.05	±0.1					
18	-	20±0.1	20	10	-	-	99	-	3.1±0.1	7.5	6.7
25	74	44±0.2	40	30	60	-	118.5	10	2.1±0.2	7.5	8
32	100	70±0.2	40	45	85	-	145.7	10	2.1±0.2	7.5	8
40	116	76±0.2	40	60	110	-	195.4	10.5	2.1±0.2	7.5	8.5
63	169	99±0.2	40	70	130	190	280	15.5	2.1±0.2	18	13.6

# Linear drives DGCI, with displacement encoder

Technical data

FESTO

## Dimensions

Download CAD data → [www.festo.com](http://www.festo.com)

Slide, variant GP – Protected recirculating ball bearing guide

Ø 18

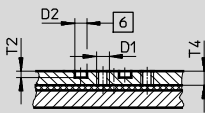

View A

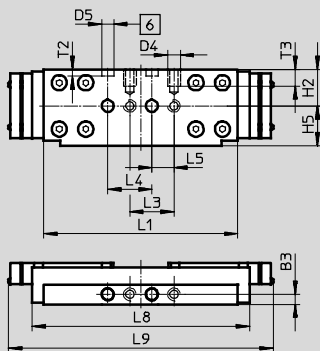

Ø 25

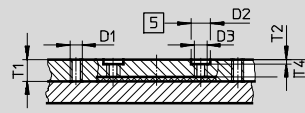

View A

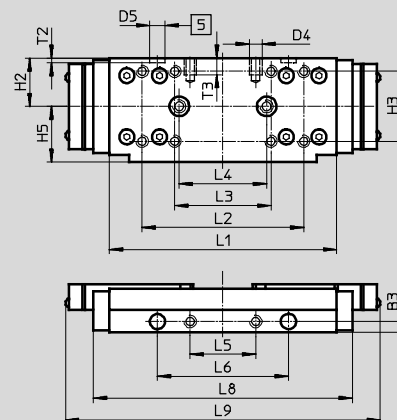

Ø 32

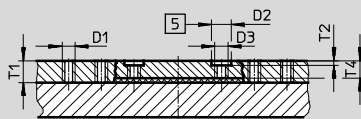

View A

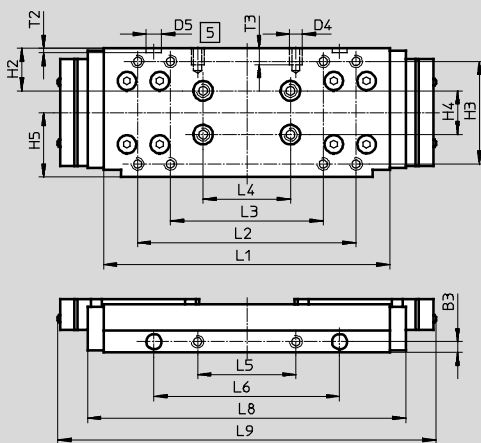

Ø 40

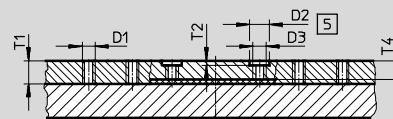

View A

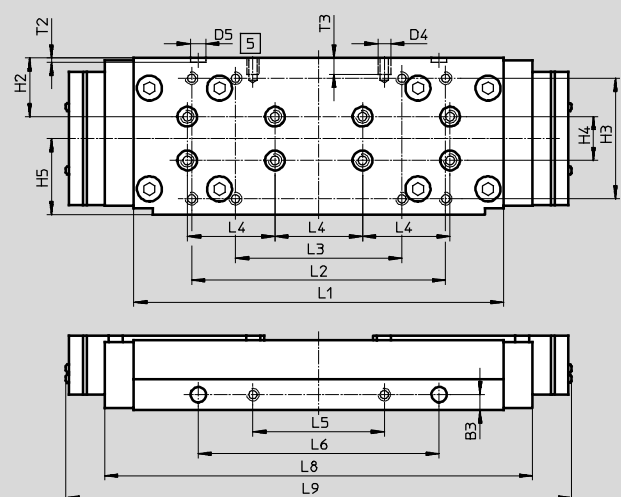

5 Hole for centring sleeve ZBH

6 Hole for centring pin ZBS

# Linear drives DGCI, with displacement encoder

Technical data

∅ [mm]	B3 ±0.05	D1	D2 ∅ H7	D3	D4	D5 ∅ H7	H2	H3
18	4.5	M5	5	–	M5	5	16.5	–
25	5	M5	9	M6	M5	7	22	32±0.2
32	5	M5	9	M6	M5	7	19.5	47±0.2
40	7	M5	9	M6	M6	7	26.8	55±0.2

∅ [mm]	H4 ±0.03	H5 ±0.1	L1	L2 ±0.2	L3	L4 ±0.03	L5 ±0.1	L6 ±0.05
18	–	18	88±0.1	–	20±0.1	20	10	–
25	–	25.5	104±0.2	74	44±0.2	40	30	60
32	20	29.5	131±0.2	100	70±0.2	40	45	85
40	20	34.7	169±0.2	116	76±0.2	40	60	110

∅ [mm]	L8	L9	T1	T2	T3	T4
18	99	120	–	3.1±0.1	7.5	6.7
25	118.5	144	10	2.1±0.2	7.5	8
32	145.7	173	10	2.1±0.2	7.5	8
40	195.4	231	10.5	2.1±0.2	7.5	8.5

# Linear drives DGCI, with displacement encoder

Technical data

FESTO

## Dimensions

Download CAD data → [www.festo.com](http://www.festo.com)

Slide, variant C – Lubrication adapter

Ø 25

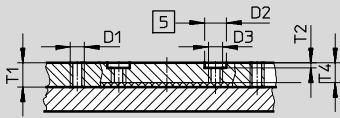

View A

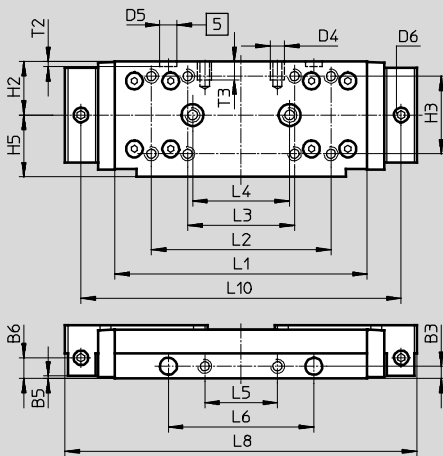

Ø 32

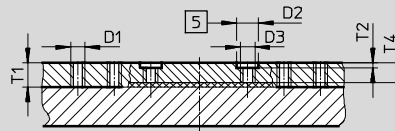

View A

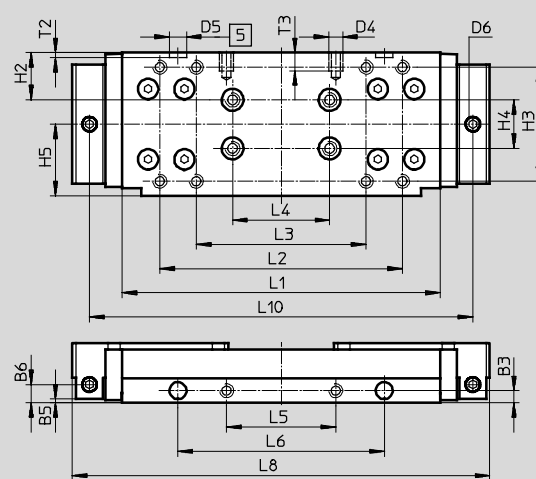

Ø 40

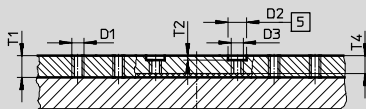

View A

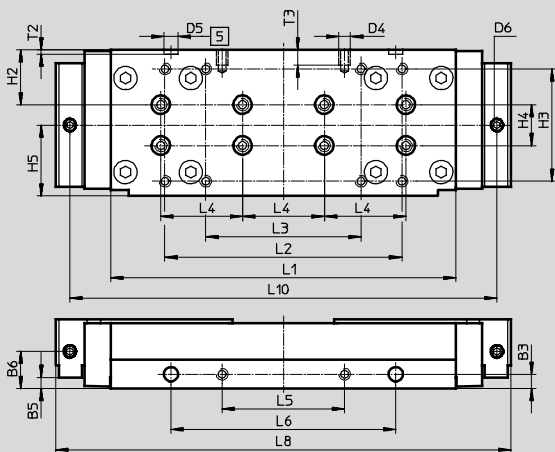

Ø 63

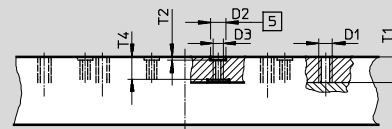

View A

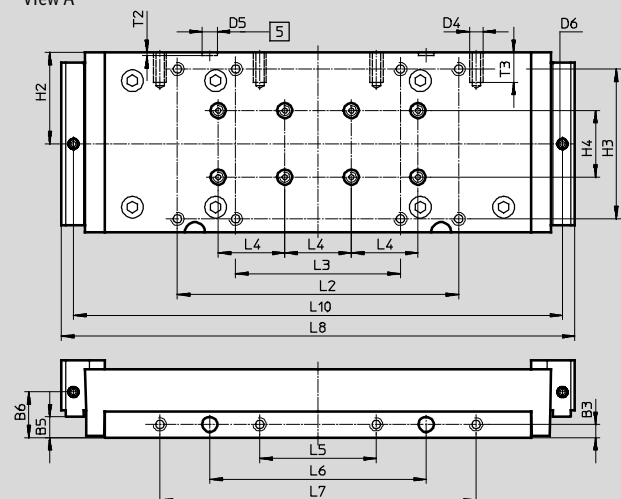

5 Hole for centring sleeve ZBH

# Linear drives DGCI, with displacement encoder

Technical data

∅	B3	B5	B6	D1	D2	D3	D4	D5	D6	H2	H3	H4	H5
[mm]	±0.05	±0.05			∅ H7			∅ H7				±0.03	±0.1
25	5	1	8.5	M5	9	M6	M5	7	M6x1	22	32±0.2	-	25.5
32	5	1.5	7.5	M5	9	M6	M5	7	M6x1	19.5	47±0.2	20	29.5
40	7	18.2	18.2	M5	9	M6	M6	7	M6x1	26.8	55±0.2	20	34.7
63	8	12.5	27.5	M8	9	M6	M8	9	M6x1	55	90±0.3	40	-

∅	L1	L2	L3	L4	L5	L6	L7	L8	L10	T1	T2	T3	T4
[mm]		±0.2	±0.2	±0.03	±0.1	±0.05	±0.1				+0.2		
25	104±0.2	74	44	40	30	60	-	145	132	10	2.1	7.5	8
32	131±0.2	100	70	40	45	85	-	172	158	10	2.1	7.5	8
40	169±0.2	116	76	40	60	110	-	223	209	10.5	2.1	7.5	8.5
63	256±0.1	169	99	40	70	130	190	308.4	293.8	15.5	2.1	18	13.6

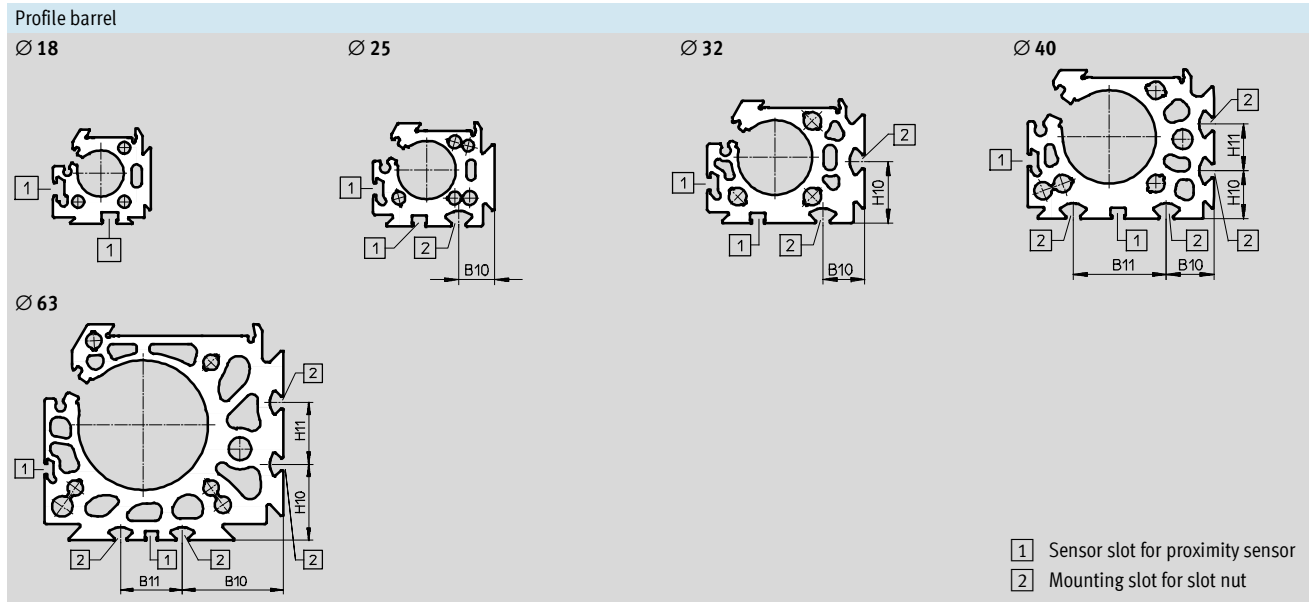

∅	B10	B11	H10	H11
[mm]				
25	15.23	-	-	-
32	18	-	26.5	-
40	20.5	40	20.5	20
63	49	30	37	30

## Linear drives DGCI, with displacement encoder

Technical data

### Dimensions

Download CAD data → [www.festo.com](http://www.festo.com)

1H – With clamping unit

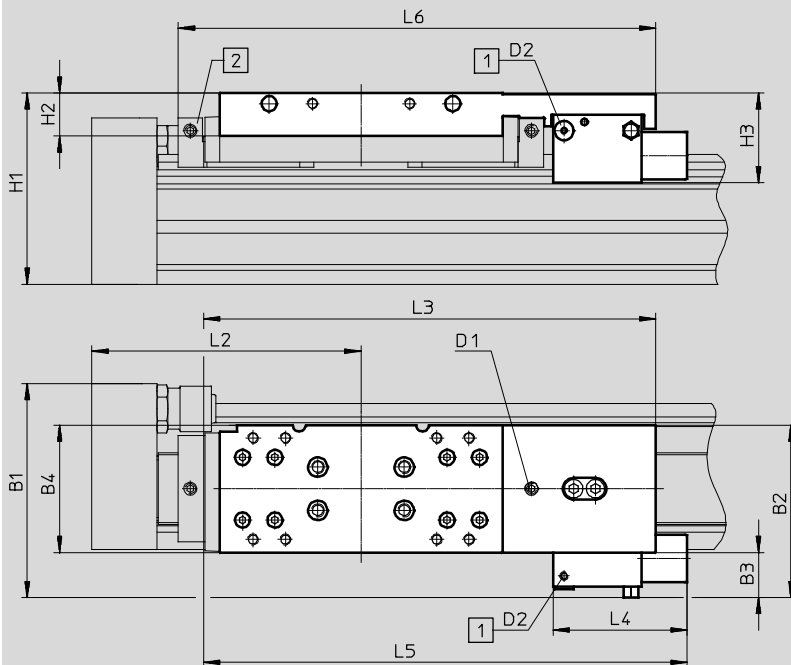

Size 25/32



 Note

Total length L1 with stroke = 0 mm → 25

In case of subsequent installation/modification, note that the dimension H1 is bigger on a linear drive with clamping unit.

 Supply port  
 Lubrication adapter

Type	B1	B2	B3	B4	H1	H2	H3	D1	D2	L2	L3	L4	L5	L6
DGCI-25-...-1H-PN	83.6	64.9	17.6	47.5	79	21	39.5	M6	M5	100	182.3	63	198	-
DGCI-25-...-C-1H-PN														193.8
DGCI-32-...-1H-PN	99.9	79.9	20.9	59	88.5	20	41.5	M6	M5	124.8	209.4	62	223.9	-
DGCI-32-...-C-1H-PN														221



# Linear drives DGCI, with displacement encoder

Technical data

**Dimensions**

Download CAD data → [www.festo.com](http://www.festo.com)

1H – With clamping unit

Size 40

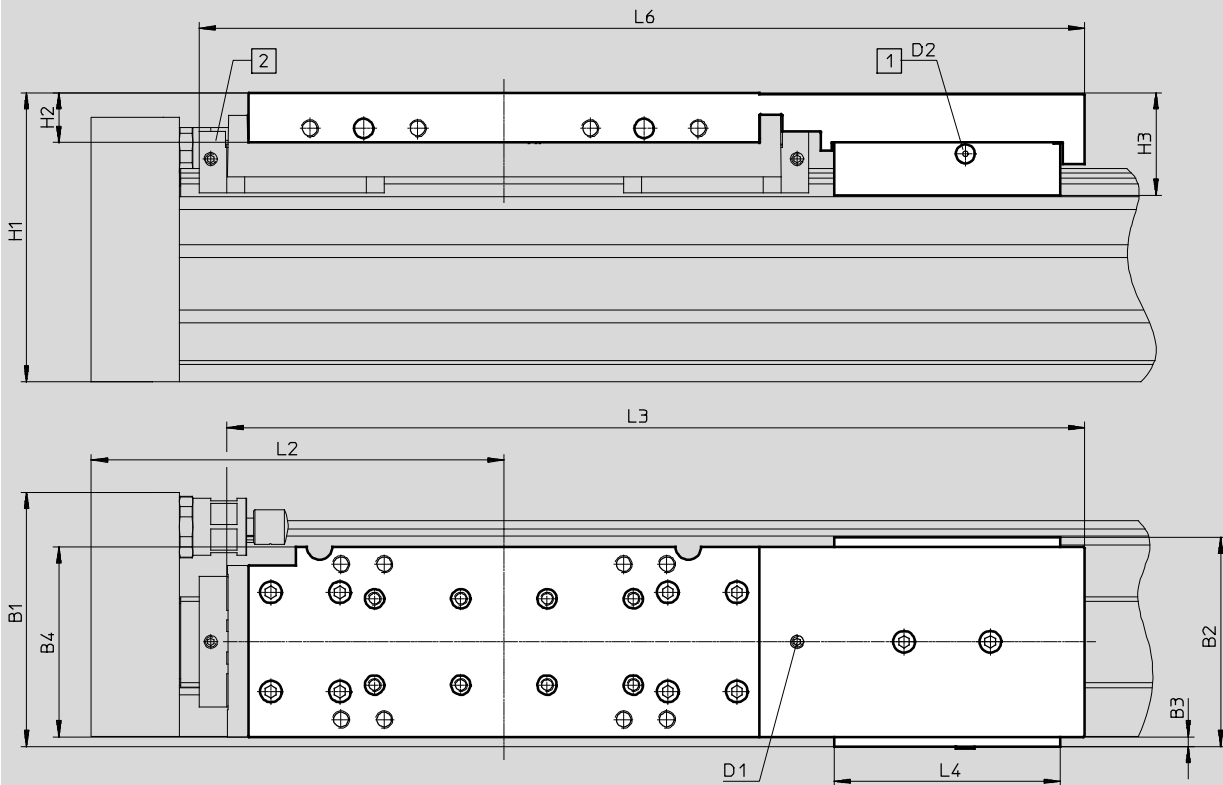

 Note

Total length L1 with stroke = 0 mm → 25

In case of subsequent installation/modification, note that the dimension H1 is bigger on a linear drive with clamping unit.

- 1 Supply port
- 2 Lubrication adapter

Type	B1	B2	B3	B4	H1	H2	H3	D1	D2	L2	L3	L4	L6
DGCI-40-...-1H-PN	109.9	97	11.7	69.4	113.5	28	48.9	M6	M5	150	331.2	105	-
DGCI-40-...-C-1H-PN													345.7

# Linear drives DGCI, with displacement encoder

Ordering data – Modular products

FESTO

## Order code

Mandatory data/options

-  - Note

Drive must not be operated without end stops or shock absorbers.

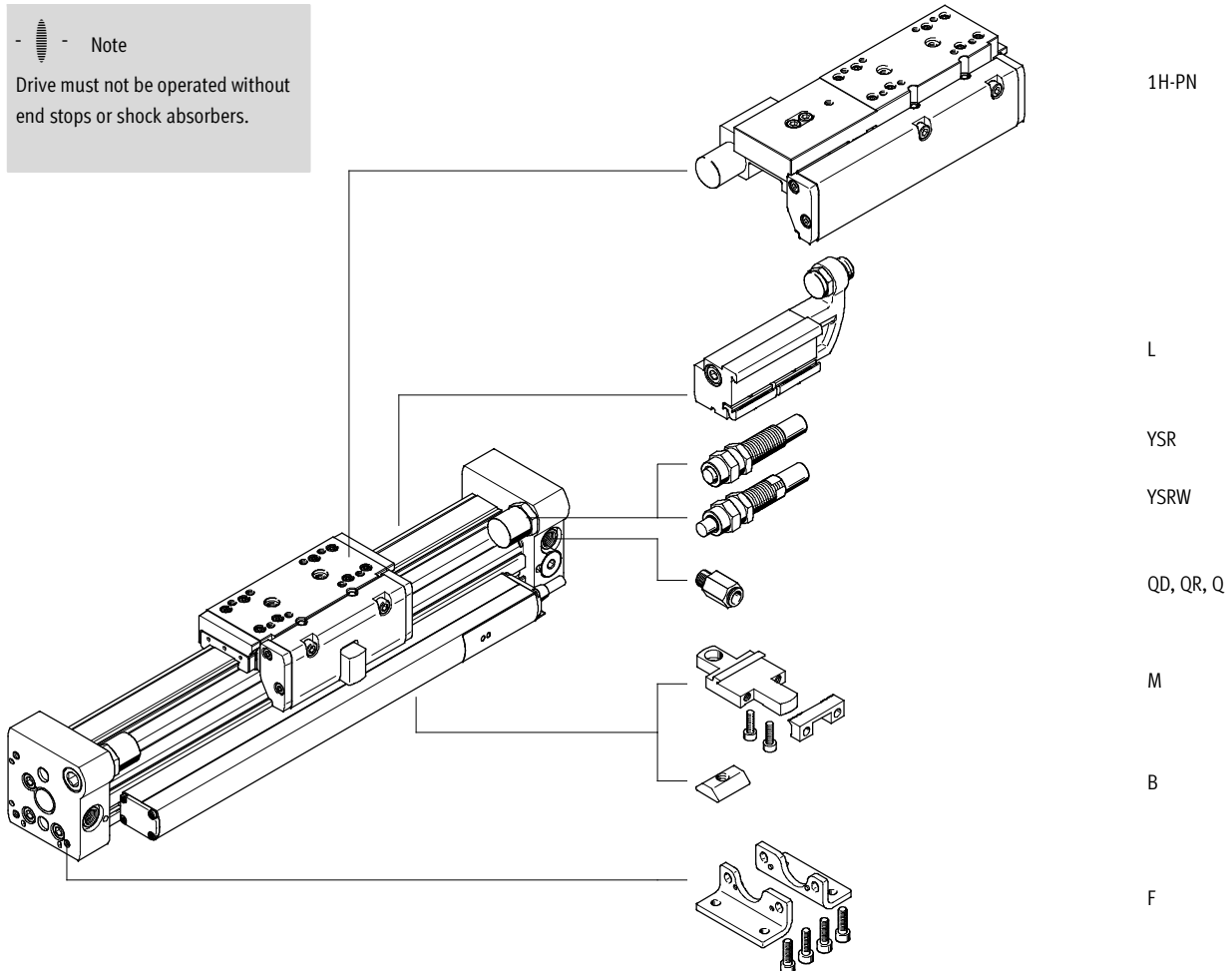

## Effective stroke reduction when ordering an additional slide KL or KR

For a linear drive DGCI with additional slide, the effective stroke is reduced by the length of the additional slide and the distance between both slides.

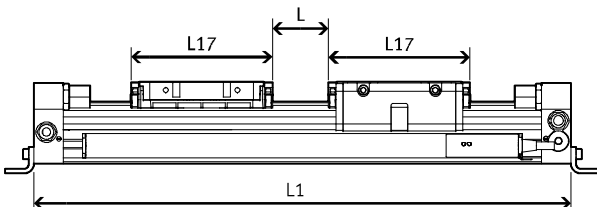

Given:  
 DGCI-18-500-...  
 L = 20 mm  
 L17 = 99 mm

The effective stroke is reduced to  
 381 mm = 500 mm – 20 mm – 99 mm

∅ [mm]	L17	
	DGCI-...-KF	DGCI-...-KF-...-GP
18	99	120
25	118.5	144
32	145.7	173
40	195.4	231
63	280	–

# Linear drives DGCI, with displacement encoder

Ordering data – Modular product

## Order code – Alternative supply port

Four different supply port options (see below) can be selected when ordering the linear drive.

To make commissioning easier, the linear drive is supplied with different

coloured push-in fittings (black or blue release ring) and without push-in

fittings in the case of the variant DGCI-...Q.

Push-in fitting at both ends, front (standard)  
DGCI-...

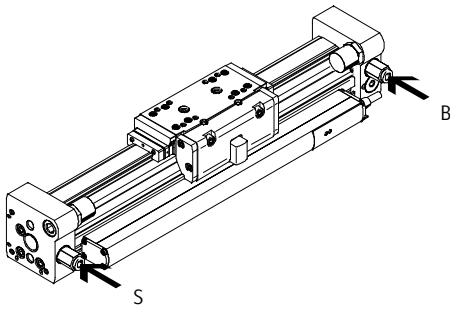

Push-in fitting at both ends, end face  
DGCI-...-QD

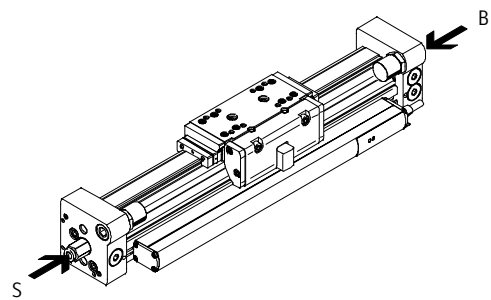

Push-in fitting at one end, end face  
DGCI-...-QR

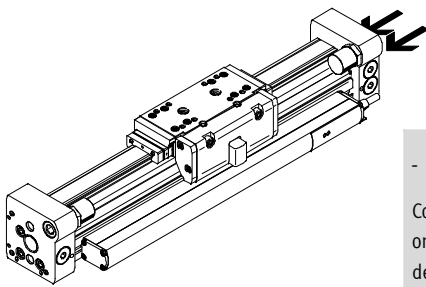

No push-in fitting, end face open  
DGCI-...Q

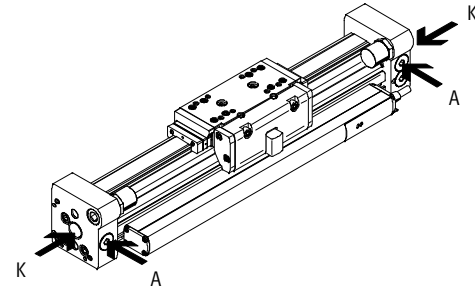

-  - Note  
Compressed air supply at one end is only recommended for strokes up to 600 mm.

## Direction of movement of the slide:

S To the right:  
Fitting with black release ring

B To the left:  
Fitting with blue release ring

## Alternative port option

K Supply ports open

A Supply ports sealed

## Order code

KL/KR – With additional slide

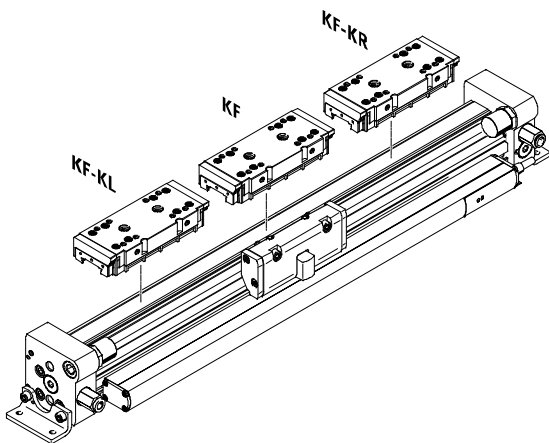

GP – With protected recirculating ball bearing guide

-  - Note  
In the case of the variant with GP, only fixed stops may be used in the end caps. Shock absorbers may only be used in combination with the shock absorber retainer DADP-DGC.

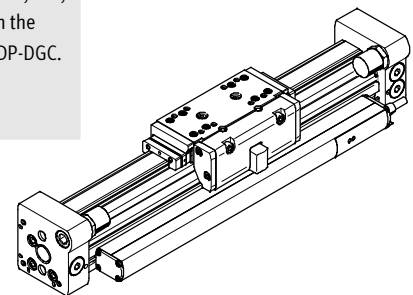

# Linear drives DGCI, with displacement encoder

Ordering data – Modular product

Ordering table									
Size	18	25	32	40	63	Condi- tions	Code	Enter code	
<b>M</b>	Module No.	<b>544425</b>	<b>544426</b>	<b>544427</b>	<b>544428</b>	<b>544429</b>			
	Function	Linear drive with displacement encoder						<b>DGCI</b>	DGCI
	Piston Ø [mm]	18	25	32	40	63	-...		
	Stroke [mm]	100; 160; 225; 300; 360; 450; 500; 600; 750; 850; 1,000; 1,250; 1,500; 1,750; 2,000						-...	
	Guide	Recirculating ball bearing guide						<b>-KF</b>	-KF
<b>O</b>	Alternative supply port	Push-in fitting at both ends, front face (standard)							
		Push-in fitting at both ends, end face						<b>-QD</b>	
		Push-in fitting at one end, end face, right side					<b>1</b>	<b>-QR</b>	
		Threaded connection (end face open, front face sealed)						<b>-Q</b>	
<b>↓</b>		M5	G½	G½	G¼	G¾			

**1 QR** Only for stroke 100 ... 600 mm

Transfer order code

## Linear drives DGCI, with displacement encoder

Ordering data – Modular product

Ordering table									
Size	18	25	32	40	63	Condi- tions	Code	Enter code	
Slide	Protected recirculating ball bearing guide						2	-GP	
Lubrication	Standard								
	Lubrication approved for use in food applications						3	-H1	
Lubrication function	Standard								
		Lubrication adapter						-C	
Additional slide on left	Additional slide, standard, on left						4	-KL	
Additional slide on right	Additional slide, standard, on right						4	-KR	
Clamping unit	None								
		1-channel					5	-1H	
Actuation type	None								
		Pneumatically actuated					5	-PN	
Cushioning	Adjustable mechanical stop without cushioning (standard)								
	Shock absorber, self-adjusting							-YSR	
	Shock absorber, self-adjusting, progressive							-YSRW	
Accessories								ZUB-	ZUB-
Type of mounting	Foot mounting (includes 0 ... 2 profile mountings depending on the stroke)						7	F	
	Profile mounting (2 ... 4 depending on the stroke)						7	M	
Slot cover for sensor slot	1 ... 9							...L	
Slot nut for mounting slot		1 ... 9						...B	
User documentation	Express waiver - no operating instructions to be included (already available) (operating instructions in PDF format are available free of charge on our website at <a href="http://www.festo.com">http://www.festo.com</a> )							O	

- 2 **GP** Not with YSR, YSRW and C
- 3 **H1** Not with protected version GP; cushioning YSR, YSRW or clamping unit 1H
- 4 **KL, KR** For a linear drive DGCI with additional slide (KL, KR), the effective stroke per additional slide is reduced by the dimension in the table → 34 plus the distance between the slides
- 5 **1H, PN** Not with protected version GP; additional slide KL, KR or lubrication H1  
Only with cushioning YSRW  
1H only with PN
- 7 **F, M** Allocation table → 22

**Transfer order code**

- [ ] - [ ] - [ ] - [ ] - [ ] - [ ] - [ ] - [ ] - **ZUB** - [ ] - [ ] - [ ] - [ ]

# Linear drives DGCI, with displacement encoder

Accessories

FESTO

Foot mounting HPC  
(order code: F)

Material:  
Galvanised steel

Note  
Additional profile mountings MUC  
are required for strokes above  
400 mm → 22.

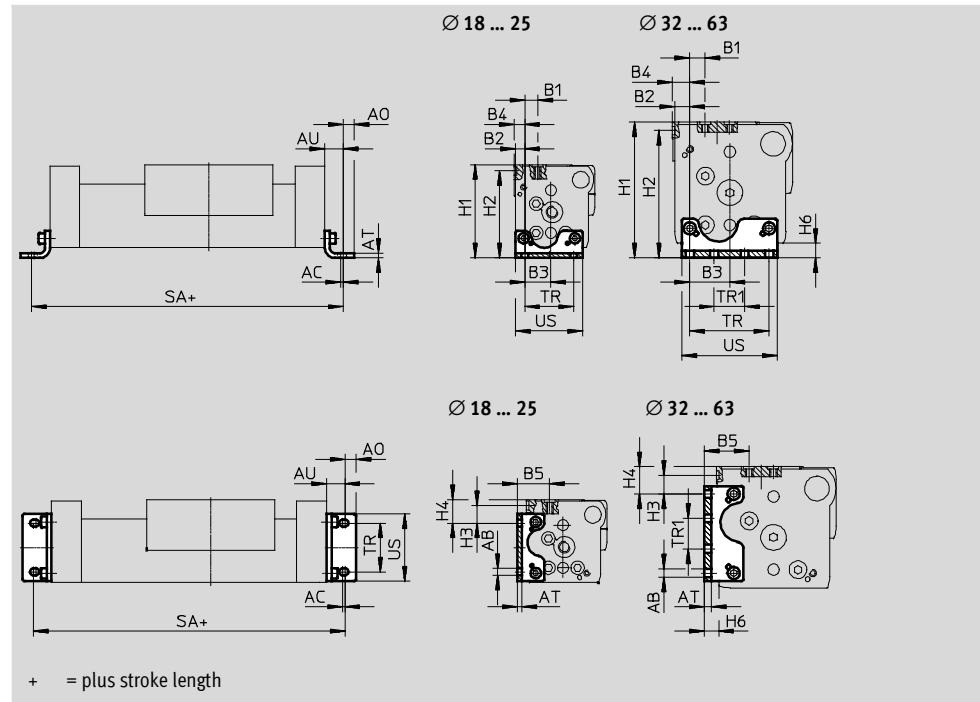

## Dimensions and ordering data

For Ø	AB Ø	AC	AO	AT	AU	B1	B2	B3
[mm]								
18	5.5	2	6.75	3	13.25	11.2	4.3	15.2
25	5.5	2	9	4	15	13.35	7.65	22.35
32	6.6	2	10	5	19	9	9	29.5
40	6.6	2	10	6	20	12.6	12.2	32.8
63	11	3	13.5	8	28	17.5	12.5	55.5

For Ø	B4	B5	H1	H2	H3	H4
[mm]						
18	5.3	23.2	64	59.5	16	21.5
25	8.65	29.5	76.5	71.5	14.35	19.35
32	10.5	27	87.5	82.5	8	13
40	14.2	36.8	111.5	104.5	15.3	22.3
63	17.5	49	172.5	164.5	22	30

For Ø	H6	SA	TR	TR1	US	Weight	Part No.	Type
[mm]		-0.2	±0.1	±0.1		[g]		
18	7.7	176.5	30	-	38.6	58	533667	HPC-18
25	8.5	230	40	-	55	131	533668	HPC-25
32	9	288	56.5	19.5	68	239	533669	HPC-32
40	12	340	65	25	78	348	533670	HPC-40
63	19	456	111	39	133	1,245	545237	HPC-63

# Linear drives DGCI, with displacement encoder

Accessories

## Profile mounting MUC (order code: M)

Material:  
High-alloy steel

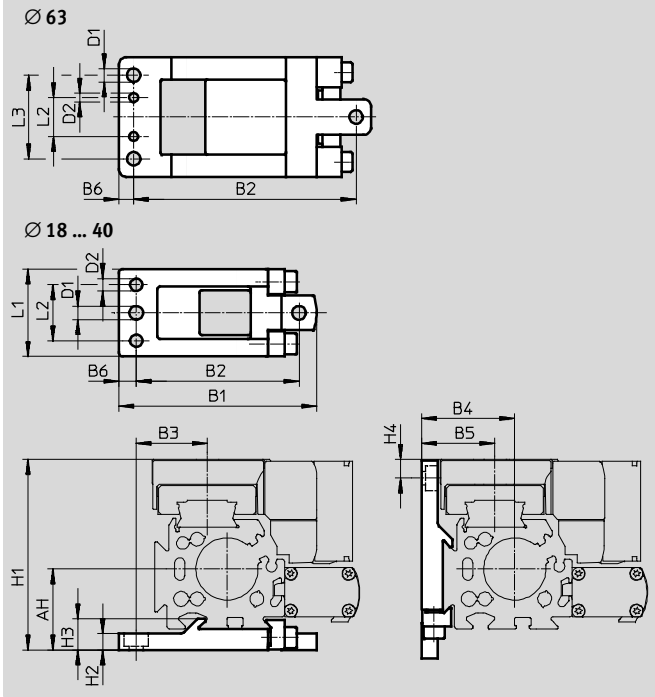

The profile mounting can only be mounted underneath in combination with the clamping unit, shock absorber retainer DADP and intermediate position module DADM.

Area of application  
→ 22

Dimensions and ordering data									
For Ø	AH	B1	B2	B3	B4	B5	B6	D1	D2
[mm]			±0.2					Ø H13	Ø H7
18	27.2	67.8±0.2	56±0.15	28.7	27.2	23.2	5.7	5.5	5
25	32.5	79.5±0.2	65.5±0.15	28.5	37.5	29.5	7	5.5	5
32	37.5	94±0.2	80±0.15	35	47.5	37	7	5.5	5
40	47	110.5±0.2	96±0.15	43	57	46.8	7	6.5	6
63	75	169±0.5	149±0.2	72.5	87	69	10	9	6

For Ø	H1	H2	H3	H4	L1	L2	L3	Weight	Part No.	Type
[mm]						±0.05	±0.2	[g]		
18	64	5.7 <sub>-0.2</sub>	9.9±0.1	6.4	33±0.1	20.5	-	78	531752	MUC-18
25	76.5	6.5 <sub>-0.2</sub>	12.5±0.1	7.43	35±0.1	22.5	-	113	531753	MUC-25
32	87.5	6.5 <sub>-0.2</sub>	13±0.1	4	45±0.1	30	-	174	531754	MUC-32
40	111.5	8.5 <sub>-0.2</sub>	16±0.1	11.3	60±0.1	44	-	346	531755	MUC-40
63	172.5	11	25.5	15	80±0.4	26	56	1,080	531757	MUC-63

# Linear drives DGCI, with displacement encoder

Accessories



**Shock absorber retainer DADP-DGC**  
**Stop KYC**

Materials: Stop  
Housing: Anodised aluminium  
Stop bracket: Stainless steel casting  
Bracket: High-alloy steel  
Free of copper and PTFE

Materials: Shock absorber retainer  
Housing: Anodised aluminium  
Free of copper and PTFE

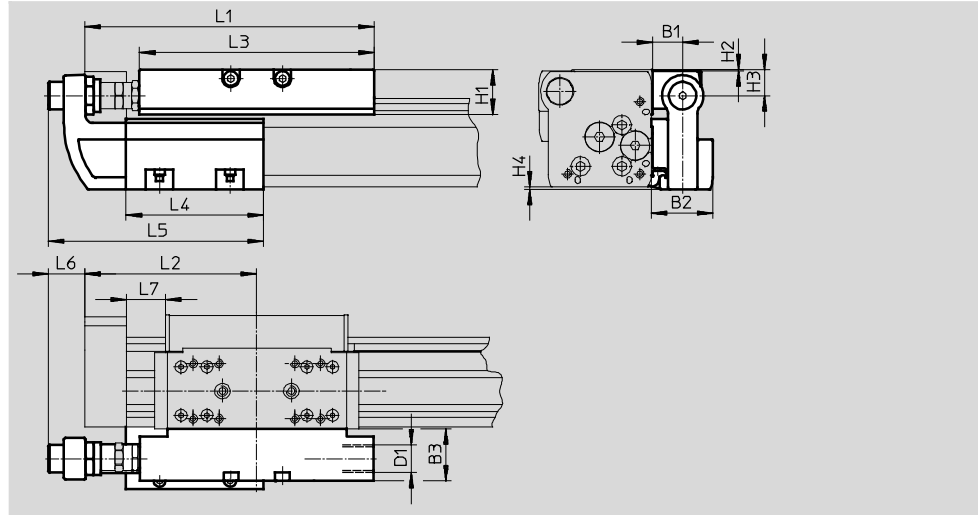

Note  
Shock absorbers are not included in the scope of delivery. Existing stop elements can be removed from the end caps of the linear drive and installed in the shock absorber retainer.

Dimensions									
For $\varnothing$	B1	B2	B3	D1	H1	H2	H3	H4	L1
[mm]									
18	16	34.5	29	M12x1	20.7	0.2	12.5	0.7	128
25	16.5	35	30	M16x1	25.5	0.5	15	1.4	168
32	16.5	35	30	M16x1	25.5	0.5	15	1.7	206.8
40	16	35.7	35	M22x1.5	37	0.5	21.5	2	255
63	25	50	40	M26x1.5	51.5	1.5	33	0	328





For $\varnothing$	L2	L3	L4	L5	L6	L7		
						KF	KF-GP	KF-YSR(W)
[mm]								
18	74.5	107	80	118.5	23.5	$\geq 14.5$	$\geq 18$	$\geq 14.5$
25	100	136	80	125	20.5	$\geq 22.5$	$\geq 25$	$\geq 22.5$
32	124.8	164	120	165	14.5	$\geq 27.3$	$\geq 27.3$	$\geq 27.3$
40	150	210	156	220.5	31	$\geq 31$	$\geq 37$	$\geq 31$
63	200	256	200	268	24	$\geq 41$	-	$\geq 41$

Note  
For reasons of functional safety of the displacement encoder and stability of the linear drive DGCI, the distance L7 must not fall below the values in the table.

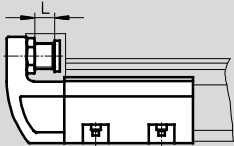

# Linear drives DGCI, with displacement encoder

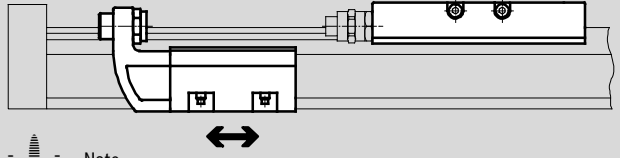
Accessories

Technical data and ordering data	Installation example
<p>Precision adjustment</p>  <p>-  - Note</p> <p>The stop KYC can be used in both directions.</p>	<p>Installation example</p>  <p>-  - Note</p> <ul style="list-style-type: none"> <li>The stop KYC can be mounted at any position along the stroke.</li> <li>Note dimension L7 → 40</li> </ul>

For Ø [mm]	Max. impact force [N]	Ambient temperature [°C]	CRC <sup>1)</sup>	Weight [g]	Part No.	Type
<b>Shock absorber retainer DADP-DGC</b>						
18	1,100	-10 ... +80	2	130	541729	DADP-DGC-18-KF
25	1,400			180	541730	DADP-DGC-25-KF
32	1,700			215	541731	DADP-DGC-32-KF
40	3,500			460	541732	DADP-DGC-40-KF
63	4,300			1,080	545245	DADP-DGC-63

1) Corrosion resistance class 2 according to Festo standard 940 070  
 Components subject to moderate corrosion stress. Externally visible parts with primarily decorative surface requirements which are in direct contact with a normal industrial environment or media such as coolants or lubricating agents.

For Ø [mm]	Precision adjustment L [mm]	Ambient temperature [°C]	CRC <sup>1)</sup>	Weight [g]	Part No.	Type
<b>Stop KYC</b>						
18	10	-10 ... +80	2	400	541691	KYC-18
25	10			560	541692	KYC-25
32	10			790	541693	KYC-32
40	15			1,525	541694	KYC-40
63	15			2,950	545243	KYC-63

1) Corrosion resistance class 2 according to Festo standard 940 070  
 Components subject to moderate corrosion stress. Externally visible parts with primarily decorative surface requirements which are in direct contact with a normal industrial environment or media such as coolants or lubricating agents.

-  - Note

Permissible impact energy  
 → 17

# Linear drives DGCI, with displacement encoder

Accessories



## Intermediate position module DADM-DGC

Materials:  
Housing: Anodised aluminium  
Stop screw, nut: Galvanised steel

Bracket, lever:  
High-alloy steel  
Free of copper and PTFE

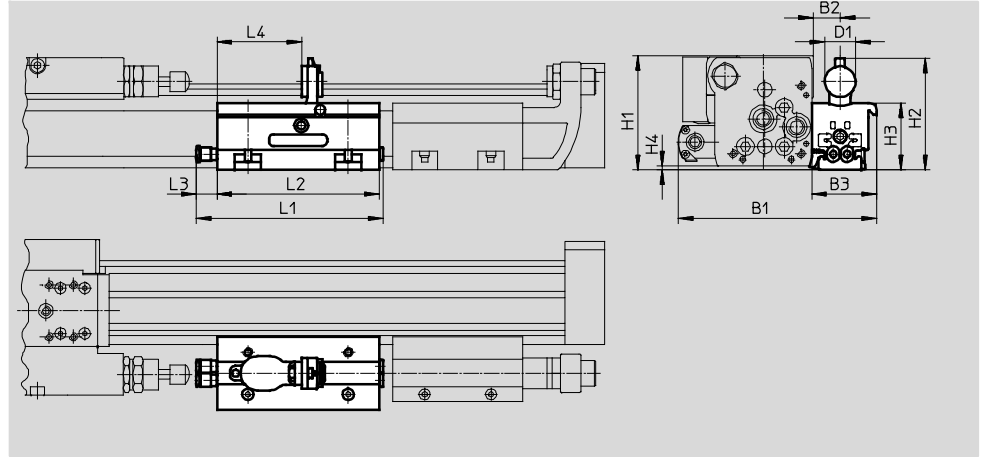

Note

- Shock absorbers are not included in the scope of delivery. Existing shock absorbers can be removed from the end caps of the linear drive and installed in the shock absorber retainer. Under no circumstances may the linear drive and the intermediate position module be operated without a shock absorber.
- A shock absorber retainer DADP-DGC and a stop KYC are additionally needed when using an intermediate position module.
- The projection (dimension H4) must be observed when using the drive in combination with the intermediate position module DADM-DGC. Mounting via foot mountings HPC or profile mountings MUC is recommended in this case.

Dimensions						
For $\varnothing$ [mm]	B1	B2	B3	D1	H1	H2
25	122.5	16.5	40	19	69.4	68.6
32	138	16.5	40	19	80.2	79.7

For $\varnothing$ [mm]	H3	H4	L1	L2	L3	L4
25	41	1.4	116	100	13.4	52.2
32	52	1.7	116	100	13.4	52.2

Note

Permissible impact energy  
→ 17

# Linear drives DGCI, with displacement encoder

Accessories

## Minimum distance

Between end stop and intermediate position

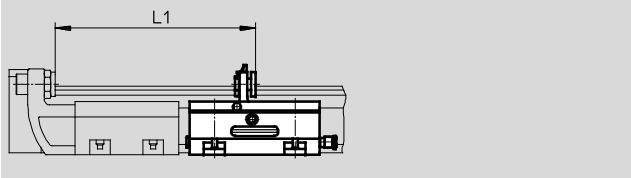

∅	L1
25	145.3
32	185.3

Between two intermediate positions

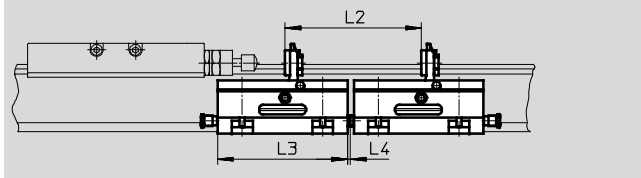

∅	L2	L3	L4
25	105	100	2.5
32	105	100	2.5

## Technical data and ordering data

Precision adjustment L

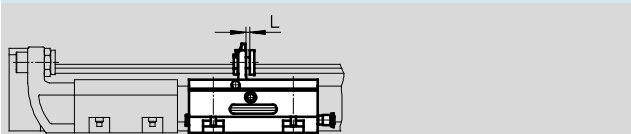

-  - Note

The intermediate position module DADM-DGC can be used in both directions. A shock absorber retainer DADP-DGC and a stop KYC are additionally needed when using an intermediate position module.

Installation example

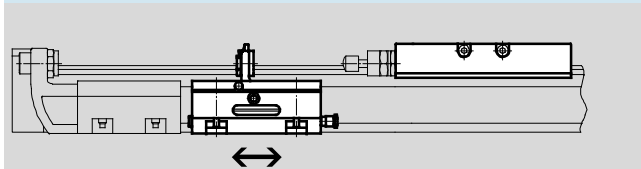

-  - Note

The intermediate position module DADM-DGC can be mounted at any position along the stroke.



For ∅ [mm]	Operating pressure [bar]	Impact velocity [m/s]	Swivel time [ms]	Repetition accuracy [mm]	Pneumatic connection	Precision adjustment L [mm]
25 32	2.5 ... 8	→ 21	<100	0.02	QS-4	2

For ∅ [mm]	Ambient temperature [°C]	CRC <sup>1)</sup>	Mounting position	Position sensing	Weight [g]	Part No.	Type
25 32	-10 ... +60	2	Any	For proximity sensor SME/SMT-10	430 530	<b>541700</b> <b>541701</b>	<b>DADM-DGC-25-A</b> <b>DADM-DGC-32-A</b>

1) Corrosion resistance class 2 according to Festo standard 940 070  
Components subject to moderate corrosion stress. Externally visible parts with primarily decorative surface requirements which are in direct contact with a normal industrial environment or media such as coolants or lubricating agents.

# Linear drives DGCI, with displacement encoder

Accessories

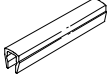
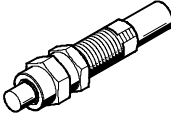
Ordering data						
	For Ø	Comment	Order code	Part No.	Type	PU <sup>1)</sup>
Slot nut HMBN <span style="float:right">Technical data → Internet: hmbn</span>						
	25 ... 40	For mounting slot	B	547264	HMBN-5-1M5	10
	63			186566	HMBN-5-2M5	
Centring pin/sleeve ZBS, ZBH <span style="float:right">Technical data → Internet: zbs, zbh</span>						
	18	For slide	-	150928	ZBS-5	10
	25 ... 63			150927	ZBH-9	
	18	For end cap	-	150928	ZBS-5	
	25 ... 63			150927	ZBH-9	
Slot cover ABP-S <span style="float:right">Technical data → Internet: abp</span>						
	18 ... 63	For sensor slot Every 0.5 m	L	151680	ABP-5-S	2
Shock absorber YSRW <span style="float:right">Technical data → Internet: ysrw</span>						
	18		YSRW	540347	YSRW-DGC-18-KF	1
	25			540349	YSRW-DGC-25-KF	
	32			540351	YSRW-DGC-32-KF	
	40			1232870	YSRW-DGC-40/50-B	
	63			543069	YSRW-DGC-63	

1) Packaging unit

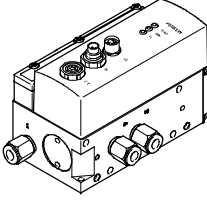
Ordering data – Proportional directional control valves and push-in fittings						
	For Ø	Stroke	Proportional directional control valve		Push-in fitting for DGCI	
	[mm]	[mm]	Technical data → Internet: vpwp		Technical data → Internet: quick star	
			Part No.	Type	Part No.	Type
	For applications with axis controller CPX-CMAX					
	18	100 ... 2,000	550170	VPWP-4-L-5-Q6-10-E-...	153306	QSM-M5-6
	25	100 ... 160	550170	VPWP-4-L-5-Q6-10-E-...	186096	QS-G <sup>1</sup> / <sub>8</sub> -6
		225 ... 600	550170	VPWP-4-L-5-Q8-10-E-...	186098	QS-G <sup>1</sup> / <sub>8</sub> -8
		750 ... 2,000	550171	VPWP-6-L-5-Q8-10-E-...	186098	QS-G <sup>1</sup> / <sub>8</sub> -8
	32	100 ... 400	550170	VPWP-4-L-5-Q8-10-E-...	186098	QS-G <sup>1</sup> / <sub>8</sub> -8
		450 ... 2,000	550171	VPWP-6-L-5-Q8-10-E-...	186098	QS-G <sup>1</sup> / <sub>8</sub> -8
	40	100 ... 300	550170	VPWP-4-L-5-Q8-10-E-...	186099	QS-G <sup>1</sup> / <sub>4</sub> -8
		360 ... 750	550171	VPWP-6-L-5-Q8-10-E-...	186099	QS-G <sup>1</sup> / <sub>4</sub> -8
		850 ... 2,000	550172	VPWP-8-L-5-Q10-10-E-...	186101	QS-G <sup>1</sup> / <sub>4</sub> -10
	63	100 ... 300	550171	VPWP-6-L-5-Q8-10-E-...	186100	QS-G <sup>3</sup> / <sub>8</sub> -8
		360 ... 750	550172	VPWP-8-L-5-Q10-10-E-...	186102	QS-G <sup>3</sup> / <sub>8</sub> -10
850 ... 2,000		1552544	VPWP-10-L-5-Q-10-E-G-EX1	186103	QS-G <sup>3</sup> / <sub>8</sub> -12	

1) Packaging unit

# Linear drives DGCI, with displacement encoder

Accessories

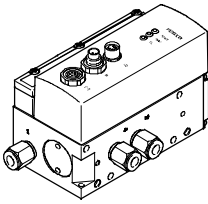
Ordering data – Proportional directional control valves and push-in fittings								
	For Ø	Stroke	Proportional directional control valve		Push-in fitting for DGCI			
	[mm]	[mm]	Technical data → Internet: vpwp		Technical data → Internet: quick star			
			Part No.	Type	Part No.	Type	PU <sup>1)</sup>	
	For applications with Soft Stop end-position controller CPX-CMPX, horizontal							
	18	100 ... 1,750	550170	VPWP-4-L-5-Q6-10-E...	153306	QSM-M5-6	10	
		2,000	550171	VPWP-6-L-5-Q-10-E...	153306	QSM-M5-6		
	25	100 ... 160	550170	VPWP-4-L-5-Q6-10-E...	186096	QS-G <sup>1</sup> / <sub>8</sub> -6		
		225 ... 300	550170	VPWP-4-L-5-Q8-10-E...	186098	QS-G <sup>1</sup> / <sub>8</sub> -8		
		360 ... 2,000	550171	VPWP-6-L-5-Q8-10-E...	186098	QS-G <sup>1</sup> / <sub>8</sub> -8		
	32	100	550170	VPWP-4-L-5-Q6-10-E...	186096	QS-G <sup>1</sup> / <sub>8</sub> -6		
		160 ... 1,000	550171	VPWP-6-L-5-Q8-10-E...	186098	QS-G <sup>1</sup> / <sub>8</sub> -8		
		1,250 ... 2,000	550172	VPWP-8-L-5-Q-10-E...	186098	QS-G <sup>1</sup> / <sub>8</sub> -8		
	40	100 ... 500	550171	VPWP-6-L-5-Q8-10-E...	186099	QS-G <sup>1</sup> / <sub>4</sub> -8		
		600 ... 750	550172	VPWP-8-L-5-Q-10-E...	186099	QS-G <sup>1</sup> / <sub>4</sub> -8		
		850 ... 2,000	550172	VPWP-8-L-5-Q10-10-E...	186101	QS-G <sup>1</sup> / <sub>4</sub> -10		
	63	100 ... 160	550170	VPWP-4-L-5-Q8-10-E...	186100	QS-G <sup>3</sup> / <sub>8</sub> -8		
		225 ... 300	550171	VPWP-6-L-5-Q8-10-E...	186100	QS-G <sup>3</sup> / <sub>8</sub> -8		
		360 ... 450	550172	VPWP-8-L-5-Q10-10-E...	186102	QS-G <sup>3</sup> / <sub>8</sub> -10		
		500 ... 2,000	1552544	VPWP-10-L-5-Q-10-E-G-EX1	186103	QS-G <sup>3</sup> / <sub>8</sub> -12		
	For applications with Soft Stop end-position controller CPX-CMPX, vertical							
	18	100 ... 1,750	550170	VPWP-4-L-5-Q6-10-E...	153306	QSM-M5-6	10	
		2,000	550171	VPWP-6-L-5-Q-10-E...	153306	QSM-M5-6		
	25	100 ... 160	550170	VPWP-4-L-5-Q6-10-E...	186096	QS-G <sup>1</sup> / <sub>8</sub> -6		
		225 ... 750	550170	VPWP-4-L-5-Q8-10-E...	186098	QS-G <sup>1</sup> / <sub>8</sub> -8		
		850 ... 2,000	550171	VPWP-6-L-5-Q8-10-E...	186098	QS-G <sup>1</sup> / <sub>8</sub> -8		
	32	100	550170	VPWP-4-L-5-Q6-10-E...	186096	QS-G <sup>1</sup> / <sub>8</sub> -6		
		160 ... 300	550170	VPWP-4-L-5-Q8-10-E...	186098	QS-G <sup>1</sup> / <sub>8</sub> -8		
360 ... 1,750		550171	VPWP-6-L-5-Q8-10-E...	186098	QS-G <sup>1</sup> / <sub>8</sub> -8			
2,000		550172	VPWP-8-L-5-Q-10-E...	186098	QS-G <sup>1</sup> / <sub>8</sub> -8			
40	100 ... 225	550170	VPWP-4-L-5-Q8-10-E...	186099	QS-G <sup>1</sup> / <sub>4</sub> -8			
	300 ... 750	550171	VPWP-6-L-5-Q8-10-E...	186099	QS-G <sup>1</sup> / <sub>4</sub> -8			
	850 ... 1,000	550171	VPWP-6-L-5-Q-10-E...	186101	QS-G <sup>1</sup> / <sub>4</sub> -10			
	1,250 ... 2,000	550172	VPWP-8-L-5-Q10-10-E...	186101	QS-G <sup>1</sup> / <sub>4</sub> -10			
63	100 ... 160	550170	VPWP-4-L-5-Q8-10-E...	186100	QS-G <sup>3</sup> / <sub>8</sub> -8			
	225 ... 300	550171	VPWP-6-L-5-Q8-10-E...	186100	QS-G <sup>3</sup> / <sub>8</sub> -8			
	360 ... 450	550172	VPWP-8-L-5-Q10-10-E...	186102	QS-G <sup>3</sup> / <sub>8</sub> -10			
	500 ... 2,000	1552544	VPWP-10-L-5-Q-10-E-G-EX1	186103	QS-G <sup>3</sup> / <sub>8</sub> -12			

1) Packaging unit

# Linear drives DGCI, with displacement encoder

Accessories

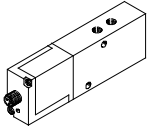
Ordering data – Proportional directional control valves and push-in fittings							
	For Ø [mm]	Stroke [mm]	Proportional directional control valve		Push-in fitting for DGCI		
			Technical data → Internet: mpye		Technical data → Internet: quick star		
			Part No.	Type	Part No.	Type	PU <sup>1)</sup>
	For applications with axis controller SPC200						
	18	100 ... 300	154200	MPYE-5-M5-010-B	153306	QSM-M5-6	10
		360 ... 2,000	151692	MPYE-5-1/8-LF-010-B	153306	QSM-M5-6	
	25	100 ... 160	154200	MPYE-5-M5-010-B	186096	QS-G1/8-6	
		225 ... 750	151692	MPYE-5-1/8-LF-010-B	186098	QS-G1/8-8	
		850 ... 2,000	151693	MPYE-5-1/8-HF-010-B	186098	QS-G1/8-8	
	32	100	154200	MPYE-5-M5-010-B	186096	QS-G1/8-6	
		160 ... 360	151692	MPYE-5-1/8-LF-010-B	186098	QS-G1/8-8	
		450 ... 2,000	151693	MPYE-5-1/8-HF-010-B	186098	QS-G1/8-8	
	40	100 ... 300	151692	MPYE-5-1/8-LF-010-B	186099	QS-G1/4-8	
		360 ... 750	151693	MPYE-5-1/8-HF-010-B	186099	QS-G1/4-8	
		850 ... 2,000	151694	MPYE-5-1/4-010-B	186101	QS-G1/4-10	
	63	100 ... 160	151692	MPYE-5-1/8-LF-010-B	186100	QS-G3/8-8	
		225 ... 300	151693	MPYE-5-1/8-HF-010-B	186100	QS-G3/8-8	
		360 ... 450	151694	MPYE-5-1/4-010-B	186102	QS-G3/8-10	
		500 ... 2,000	151695	MPYE-5-3/8-010-B	186103	QS-G3/8-12	

1) Packaging unit

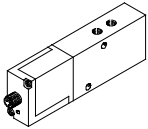
Ordering data – Proportional directional control valves and push-in fittings							
	For Ø [mm]	Stroke [mm]	Proportional directional control valve		Push-in fitting for DGCI		
			Technical data → Internet: mpye		Technical data → Internet: quick star		
			Part No.	Type	Part No.	Type	PU <sup>1)</sup>
	For applications with Soft Stop end-position controller SPC11-MTS-AIF-2, horizontal						
	18	100 ... 300	154200	MPYE-5-M5-010-B	153306	QSM-M5-6	10
		360 ... 1,750	151692	MPYE-5-1/8-LF-010-B	153306	QSM-M5-6	
		2,000	151693	MPYE-5-1/8-HF-010-B	153306	QSM-M5-6	
	25	100 ... 160	151692	MPYE-5-1/8-LF-010-B	186096	QS-G1/8-6	
		225 ... 300	151692	MPYE-5-1/8-LF-010-B	186098	QS-G1/8-8	
		360 ... 2,000	151693	MPYE-5-1/8-HF-010-B	186098	QS-G1/8-8	
	32	100	151692	MPYE-5-1/8-LF-010-B	186096	QS-G1/8-6	
		160 ... 1,000	151693	MPYE-5-1/8-HF-010-B	186098	QS-G1/8-8	
		1,250 ... 2,000	151694	MPYE-5-1/4-010-B	186098	QS-G1/8-8	
	40	100 ... 500	151693	MPYE-5-1/8-HF-010-B	186099	QS-G1/4-8	
		600 ... 750	151694	MPYE-5-1/4-010-B	186099	QS-G1/4-8	
		850 ... 2,000	151694	MPYE-5-1/4-010-B	186101	QS-G1/4-10	
	63	100 ... 160	151692	MPYE-5-1/8-LF-010-B	186100	QS-G3/8-8	
		225 ... 300	151693	MPYE-5-1/8-HF-010-B	186100	QS-G3/8-8	
		360 ... 450	151694	MPYE-5-1/4-010-B	186102	QS-G3/8-10	
500 ... 2,000		151695	MPYE-5-3/8-010-B	186103	QS-G3/8-12		

1) Packaging unit

# Linear drives DGCI, with displacement encoder

Accessories

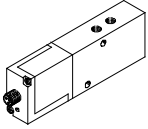
Ordering data – Proportional directional control valves and push-in fittings							
	For $\varnothing$	Stroke	Proportional directional control valve		Push-in fitting for DGCI		
	[mm]	[mm]	Technical data → Internet: mpye		Technical data → Internet: quick star		
			Part No.	Type	Part No.	Type	PU <sup>1)</sup>
	For applications with Soft Stop end-position controller SPC11-MTS-AIF-2, vertical						
	18	100 ... 300	154200	MPYE-5-M5-010-B	153306	QSM-M5-6	10
		360 ... 1,750	151692	MPYE-5-1/8-LF-010-B	153306	QSM-M5-6	
		2,000	151693	MPYE-5-1/8-HF-010-B	153306	QSM-M5-6	
	25	100 ... 160	151692	MPYE-5-1/8-LF-010-B	186096	QS-G1/8-6	
		225 ... 750	151692	MPYE-5-1/8-LF-010-B	186098	QS-G1/8-8	
		850 ... 2,000	151693	MPYE-5-1/8-HF-010-B	186098	QS-G1/8-8	
	32	100	151692	MPYE-5-1/8-LF-010-B	186096	QS-G1/8-6	
		160 ... 300	151692	MPYE-5-1/8-LF-010-B	186098	QS-G1/8-8	
		360 ... 1,750	151693	MPYE-5-1/8-HF-010-B	186098	QS-G1/8-8	
		2,000	151694	MPYE-5-1/4-010-B	186098	QS-G1/8-8	
	40	100 ... 225	151692	MPYE-5-1/8-LF-010-B	186099	QS-G1/4-8	
		300 ... 750	151693	MPYE-5-1/8-HF-010-B	186099	QS-G1/4-8	
		850 ... 1,000	151693	MPYE-5-1/8-HF-010-B	186101	QS-G1/4-10	
		1,250 ... 2,000	151694	MPYE-5-1/4-010-B	186101	QS-G1/4-10	
	63	100 ... 160	151692	MPYE-5-1/8-LF-010-B	186100	QS-G3/8-8	
		225 ... 300	151693	MPYE-5-1/8-HF-010-B	186100	QS-G3/8-8	
		360 ... 450	151694	MPYE-5-1/4-010-B	186102	QS-G3/8-10	
		500 ... 2,000	151695	MPYE-5-3/8-010-B	186103	QS-G3/8-12	

1) Packaging unit

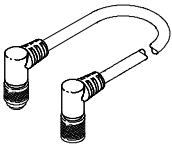
Ordering data – Connecting cables				
	Brief description	Cable length	Part No.	Type
		[m]		
Connection between axis controller CPX-CMAX/end-position controller CPX-CMPX and proportional directional control valve VPWP				
	Angled plug and angled socket	0.25	540327	KVI-CP-3-WS-WD-0,25
		0.5	540328	KVI-CP-3-WS-WD-0,5
		2	540329	KVI-CP-3-WS-WD-2
		5	540330	KVI-CP-3-WS-WD-5
		8	540331	KVI-CP-3-WS-WD-8
		Straight plug and straight socket	2	540332
	5		540333	KVI-CP-3-GS-GD-5
	8		540334	KVI-CP-3-GS-GD-8