

Racores rápidos roscados Quick Star CRQS, acero inoxidable, NPT

**FESTO**



## Racores rápidos roscados Quick Star CRQS, acero inoxidable, NPT

Datos técnicos

Datos técnicos generales	
Tamaño	Estándar
Construcción	Principio Push-Pull (presión y tracción)
Posición de montaje	Indistinta

Condiciones de funcionamiento y del entorno	
Presión de funcionamiento [psi]	-13,8 ... +203,1
Fluido de trabajo	Aire comprimido según ISO 8573-1:2010 [7:-:-]
Temperatura ambiente [°F]	-4 ... +302
Resistencia a la corrosión CRC <sup>1)</sup>	4

1) Clase de resistencia a la corrosión 4 según norma de Festo 940 070

Piezas expuestas a gran peligro de corrosión. Piezas expuestas a sustancias agresivas, por ejemplo en la industria alimentaria o química. Si procede, deben realizarse pruebas especiales con las sustancias presentes en estas aplicaciones.

### Materiales



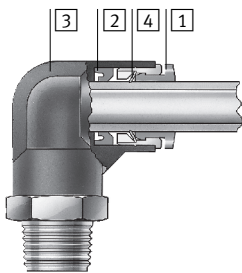



Vista en sección



	CRQS, NPT
1	Anillo para soltar Acero de aleación fina, inoxidable
2	Junta del tubo flexible FPM
3	Cuerpo Acero de aleación fina, inoxidable
4	Segmento de aprisionamiento del tubo flexible Acero de aleación fina, inoxidable
Características del material	Contiene sustancias agresivas para la laca Conformidad con RoHS

# Racores rápidos roscados Quick Star CRQS, acero inoxidable, NPT

Cuadro general de productos

Forma	Ejecución	Tipo	Conexión D1			Conexión D2		→ Página/ Internet
			Rosca NPT	Para tubo de diámetro exterior	Diámetro del casquillo enchufable	Para tubo de diámetro exterior		
Forma recta	<b>Racor rápido roscado: rosca exterior con hexágono interior y exterior</b>							
		CRQS	1/8	-	-	5/32, 1/4	4	
			1/4			1/4, 5/16, 3/8		
			3/8			3/8, 1/2		
			1/2			1/2		
	<b>Racor rápido</b>							
		CRQS-...T	-	-	5/32	-	4	
			1/4					
			5/16					
			3/8					
1/2								
<b>Racor con casquillo</b>								
	CRQS-...H	-	-	1/4	5/32	5		
		5/16		1/4				
		3/8		1/4, 5/16				
En forma de L	<b>Racor rápido en L, girable en 360°: rosca exterior con hexágono exterior</b>							
		CRQSL	1/8	-	-	5/32, 1/4	6	
			1/4			1/4, 5/16, 3/8		
			3/8			3/8, 1/2		
			1/2			1/2		
	<b>Racor rápido en L</b>							
		CRQSL-...T	-	-	5/32	-	6	
			1/4					
			5/16					
			3/8					
1/2								
En forma de T	<b>Racor rápido en L, girable en 360°: rosca exterior con hexágono exterior</b>							
		CRQST	1/8	-	-	5/32, 1/4	7	
			1/4			1/4, 5/16, 3/8		
			3/8			3/8		
	<b>Racor rápido en T</b>							
		CRQST-...T	-	-	5/32	-	7	
			1/4					
			5/16					
			3/8					
			1/2					

## Racores rápidos roscados Quick Star CRQS, acero inoxidable, NPT

Hoja de datos

### Racor rápido roscado CRQS

Rosca exterior  
con hexágono exterior

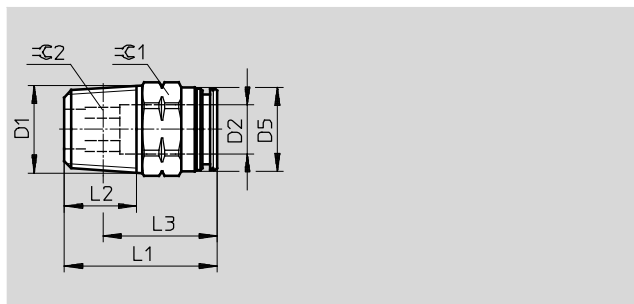

Dimensiones y referencias												
Conexión	Diámetro nominal	Para tubo de diámetro exterior	D5 $\varnothing$	L1	L2	L3	$\approx C1$	$\approx C2$	Peso/unidad	Nº art.	Tipo	PE <sup>1)</sup>
D1	[pulgadas]	D2							[oz]			
1/8	0,118	5/32	9,5	19,5	8,5	15,4	15/32	1/8	0,342	565318	CRQS-1/8-5/32-U	1
	0,157	1/4	12,0	22,0	8,5	17,9	1/2	5/32	0,388	565319	CRQS-1/8-1/4-U	1
1/4	0,157	1/4	12,0	24,5	13,0	18,7	35/64	5/32	0,628	565320	CRQS-1/4-1/4-U	1
	0,256	5/16	14,0	25,5	13,0	19,7	35/64	1/4	0,575	565321	CRQS-1/4-5/16-U	1
	0,256	3/8	16,0	32,0	13,0	26,2	21/32	1/4	0,896	565322	CRQS-1/4-3/8-U	1
3/8	0,315	3/8	16,0	25,5	13,0	19,4	45/64	5/16	0,917	565323	CRQS-3/8-3/8-U	1
	0,413	1/2	20,0	29,5	13,0	23,4	13/16	13/32	1,118	565324	CRQS-3/8-1/2-U	1
1/2	0,413	1/2	19,5	30,5	17,0	22,4	55/64	13/32	1,633	565325	CRQS-1/2-1/2-U	1

1) Cantidad por unidad de embalaje

### Racor rápido CRQS-...T

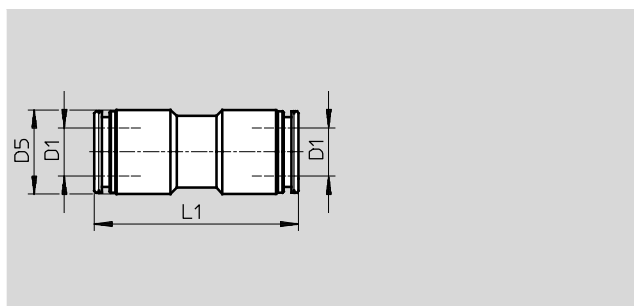

Dimensiones y referencias							
Para tubo de diámetro exterior	Diámetro nominal	D5 $\varnothing$	L1	Peso/unidad	Nº art.	Tipo	PE <sup>1)</sup>
D1	[pulgadas]			[oz]			
5/32	0,118	9,5	28,0	0,307	565340	CRQS-5/32T-U	1
1/4	0,217	12,0	33,5	0,515	565341	CRQS-1/4T-U	1
5/16	0,256	14,0	34,0	0,695	565342	CRQS-5/16T-U	1
3/8	0,335	16,0	38,5	0,945	565343	CRQS-3/8T-U	1
1/2	0,433	20,0	41,0	1,552	565344	CRQS-1/2T-U	1

1) Cantidad por unidad de embalaje

# Racores rápidos roscados Quick Star CRQS, acero inoxidable, NPT

**FESTO**

Hoja de datos

## Racor rápido CRQS-...H

Con casquillo

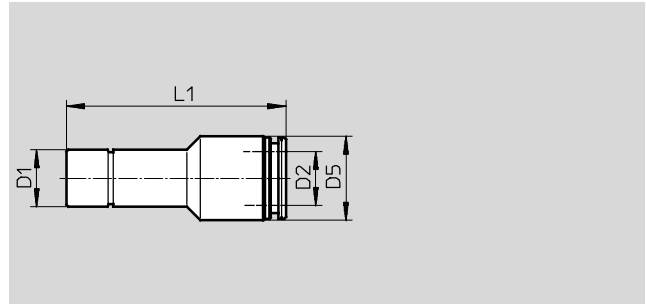

Dimensiones y referencias								
Conexión	Diámetro nominal	Para tubo de diámetro exterior	D5 Ø	L1	Peso/unidad	Nº art.	Tipo	PE <sup>1)</sup>
D1	[pulgadas]	D2			[oz]			
1/4	0,118	5/32	9,5	31,5	–	565355	CRQS-1/4H-5/32-U	1
5/16	0,197	1/4	12,0	34,5	0,406	565356	CRQS-5/16H-1/4-U	1
3/8	0,217	1/4	12,0	34,5	0,483	565357	CRQS-3/8H-1/4-U	1
	0,256	5/16	14,0	36,5	0,547	565358	CRQS-3/8H-5/16-U	1

1) Cantidad por unidad de embalaje

## Racores rápidos roscados Quick Star CRQS, acero inoxidable, NPT

Hoja de datos

### Racor rápido roscado en L CRQSL

Orientable en 360°

Rosca exterior

con hexágono exterior

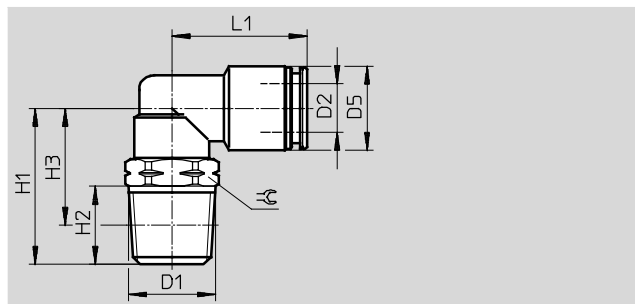

Dimensiones y referencias												
Conexión	Diámetro nominal	Para tubo de diámetro exterior	D5	H1	H2	H3	L1	⌀	Peso/unidad	Nº art.	Tipo	PE <sup>1)</sup>
D1	[pulgadas]	D2	∅						[oz]			
1/8	0,118	5/32	9,5	18,5	8,5	14,4	17,5	15/32	0,441	565326	CRQSL-1/8-5/32-U	1
	0,217	1/4	12,0	21,0	8,5	16,9	21,5	1/2	0,705	565327	CRQSL-1/8-1/4-U	1
1/4	0,217	1/4	12,0	26,0	13,0	20,2	21,5	35/64	0,97	565328	CRQSL-1/4-1/4-U	1
	0,236	5/16	14,0	26,0	13,0	20,2	22,5	35/64	0,967	565329	CRQSL-1/4-5/16-U	1
	0,335	3/8	16,0	29,0	13,0	23,2	26,0	21/32	1,376	565330	CRQSL-1/4-3/8-U	1
3/8	0,335	3/8	16,0	29,0	13,0	22,9	26,0	45/64	1,517	565331	CRQSL-3/8-3/8-U	1
	0,413	1/2	20,0	32,5	13,0	26,4	28,5	13/16	2,37	565332	CRQSL-3/8-1/2-U	1
1/2	0,413	1/2	20,0	37,0	17,0	28,9	28,5	55/64	2,723	565333	CRQSL-1/2-1/2-U	1

1) Cantidad por unidad de embalaje

### Racor rápido en L, CRQSL-...T

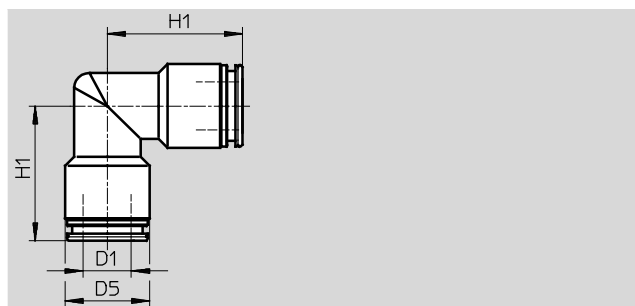

Dimensiones y referencias							
Para tubo de diámetro exterior	Diámetro nominal	D5	H1	Peso/unidad	Nº art.	Tipo	PE <sup>1)</sup>
D1	[pulgadas]	∅		[oz]			
5/32	0,138	9,5	17,5	0,444	565345	CRQSL-5/32-T-U	1
1/4	0,217	12,0	21,0	0,515	565346	CRQSL-1/4-T-U	1
5/16	0,256	14,0	22,5	0,868	565347	CRQSL-5/16-T-U	1
3/8	0,335	16,0	25,5	1,517	565348	CRQSL-3/8-T-U	1
1/2	0,433	20,0	27,5	1,781	565349	CRQSL-1/2-T-U	1

1) Cantidad por unidad de embalaje

# Racores rápidos roscados Quick Star CRQS, acero inoxidable, NPT

**FESTO**

Hoja de datos

## Racor rápido roscado en T CRQST

Orientable en 360°

Rosca exterior  
con hexágono exterior

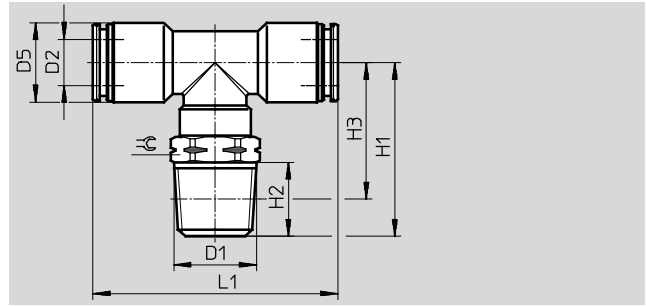

Dimensiones y referencias												
Conexión	Diámetro nominal	Para tubo de diámetro exterior	D5 Ø	H1	H2	H3	L1	⌀	Peso/unidad	Nº art.	Tipo	PE <sup>1)</sup>
D1	[pulgadas]	D2							[oz]			
1/8	0,118	5/32	9,5	22,5	8,5	18,4	35,0	15/32	0,656	565334	CRQST-1/8-5/32-U	1
	0,217	1/4	12,0	25,5	8,5	21,4	42,0	1/2	0,97	565335	CRQST-1/8-1/4-U	1
1/4	0,217	1/4	12,0	30,5	13,0	24,7	42,0	35/64	1,185	565336	CRQST-1/4-1/4-U	1
	0,236	5/16	14,0	30,5	13,0	24,7	43,0	35/64	1,305	565337	CRQST-1/4-5/16-U	1
	0,335	3/8	16,0	32,0	13,0	26,2	51,0	21/32	2,258	565338	CRQST-1/4-3/8-U	1
3/8	0,335	3/8	16,0	32,0	13,0	25,9	51,0	45/64	2,346	565339	CRQST-3/8-3/8-U	1

1) Cantidad por unidad de embalaje

## Racor rápido en T CRQST-...T

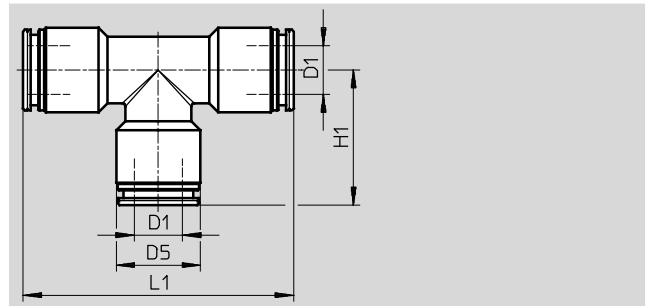

Dimensiones y referencias								
Para tubo de diámetro exterior	Diámetro nominal	D5 Ø	H1	L1	Peso/unidad	Nº art.	Tipo	PE <sup>1)</sup>
D1	[pulgadas]				[oz]			
5/32	0,138	9,5	17,5	35,0	0,564	565350	CRQST-5/32T-U	1
1/4	0,217	12,0	21,0	42,0	0,988	565351	CRQST-1/4T-U	1
5/16	0,256	14,0	21,5	43,0	1,157	565352	CRQST-5/16T-U	1
3/8	0,335	16,0	25,0	50,0	2,046	565353	CRQST-3/8T-U	1
1/2	0,433	20,0	27,5	55,0	2,469	565354	CRQST-1/2T-U	1

1) Cantidad por unidad de embalaje