

Valve terminals type 84 VTOC

FESTO



Valve terminals type 84 VTOC

Key features

FESTO

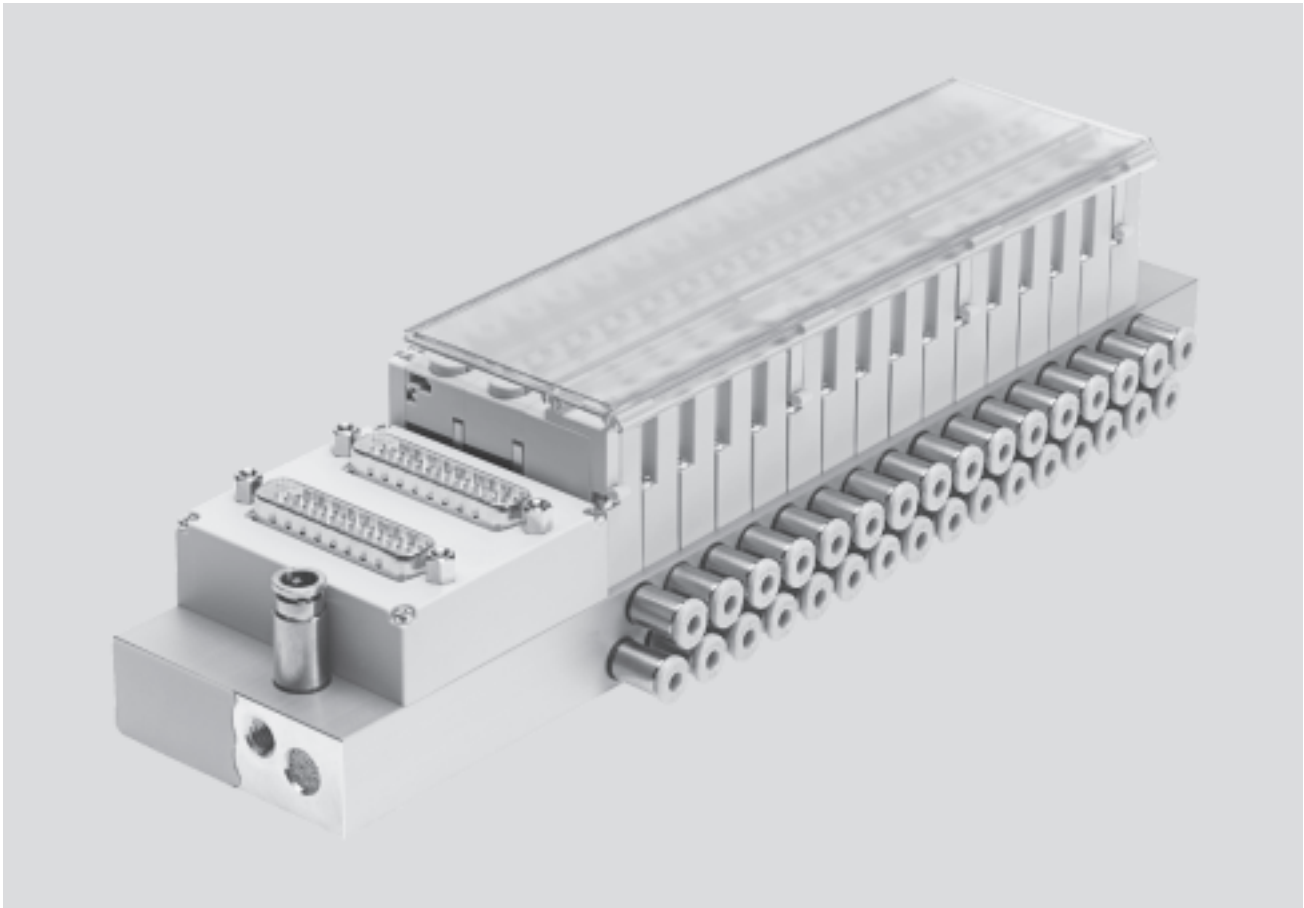

Innovative

- Valve terminal for a wide range of pneumatic applications
- Weight-optimised metal manifold rail
- Space-saving thanks to 2x3/2-way valves on one valve position
- Great flexibility during planning, assembly and operation
- Configurable manifold rails (pneumatic and electric connections)

Versatile

- Provides 2 ... 24 valve positions on one terminal
- Flexibility of the pneumatic working lines provides a practical solution to different requirements
- Wide range of electrical outlet directions
- Multi-pin plug connection with Sub-D plug or flat cable

Reliable

- Manual override
- Durable
- Sturdy thanks to simple structure

Easy to mount

- Ready-to-install and tested unit
- Lower ordering, installation and commissioning costs
- Easy valve assembly

Note

Ordering system for valve terminal type 84 VTOC
→ Internet: vtoc

Valve terminals type 84 VTOC

Key features

FESTO

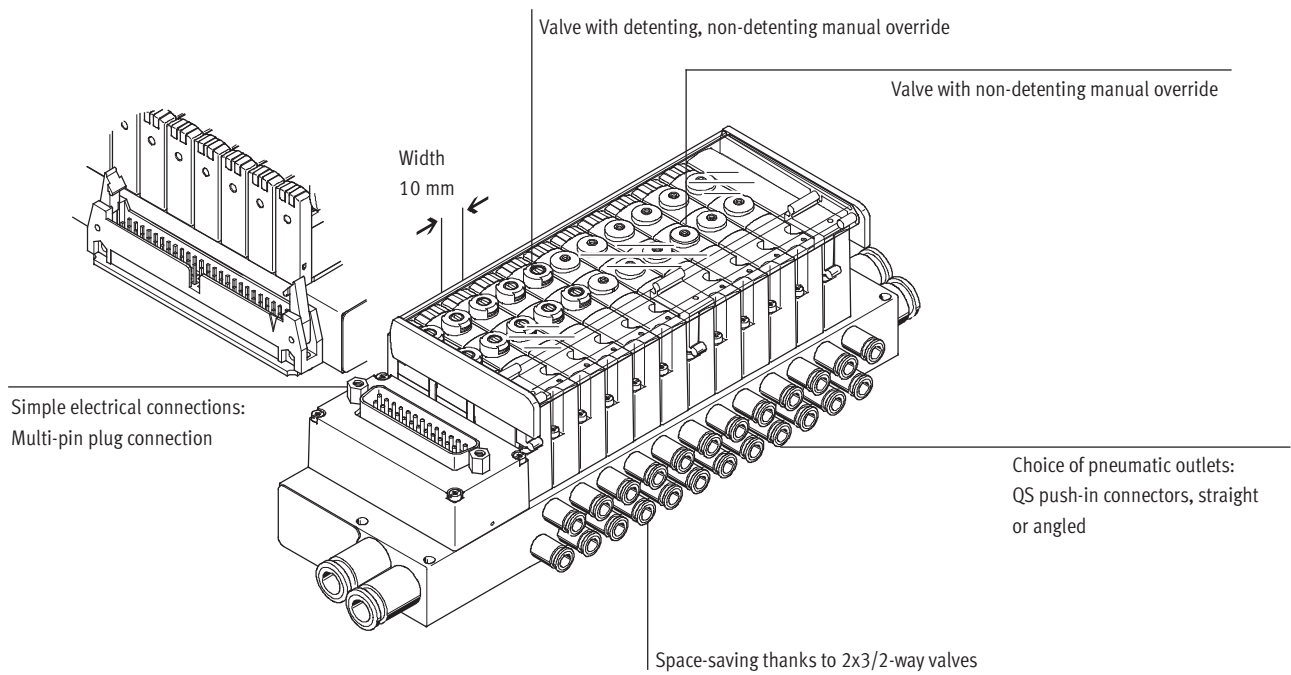

Equipment options

Valve functions

- 2x3/2-way valve, single solenoid, normally closed
- Valve with non-detenting manual override
- Valve with detenting, non-detenting manual override

Electrical connection options

- Multi-pin plug
- 2 ... 24 valve positions/
max. 48 solenoid coils
- Sub-D/flat cable

Valve terminals type 84 VTOC

Peripherals overview

Overview of valve terminals type 84 VTOC

Valve terminal with electrical multi-pin plug connection

- Up to 24 valve positions/
48 solenoid coils
- Flat cable connection type, code: RC
- Sub-D plug connection type, code:
SD

Valve terminals with electrical multi-pin plug connection are available in gradations from 2 to max. 24 valve positions. Each valve position can either be equipped with a valve body or a blanking plate.

Only valve bodies containing two single solenoid 3/2-way valves are available.

A maximum of 48 valve solenoid coils can be actuated via the electrical multi-pin plug connection.

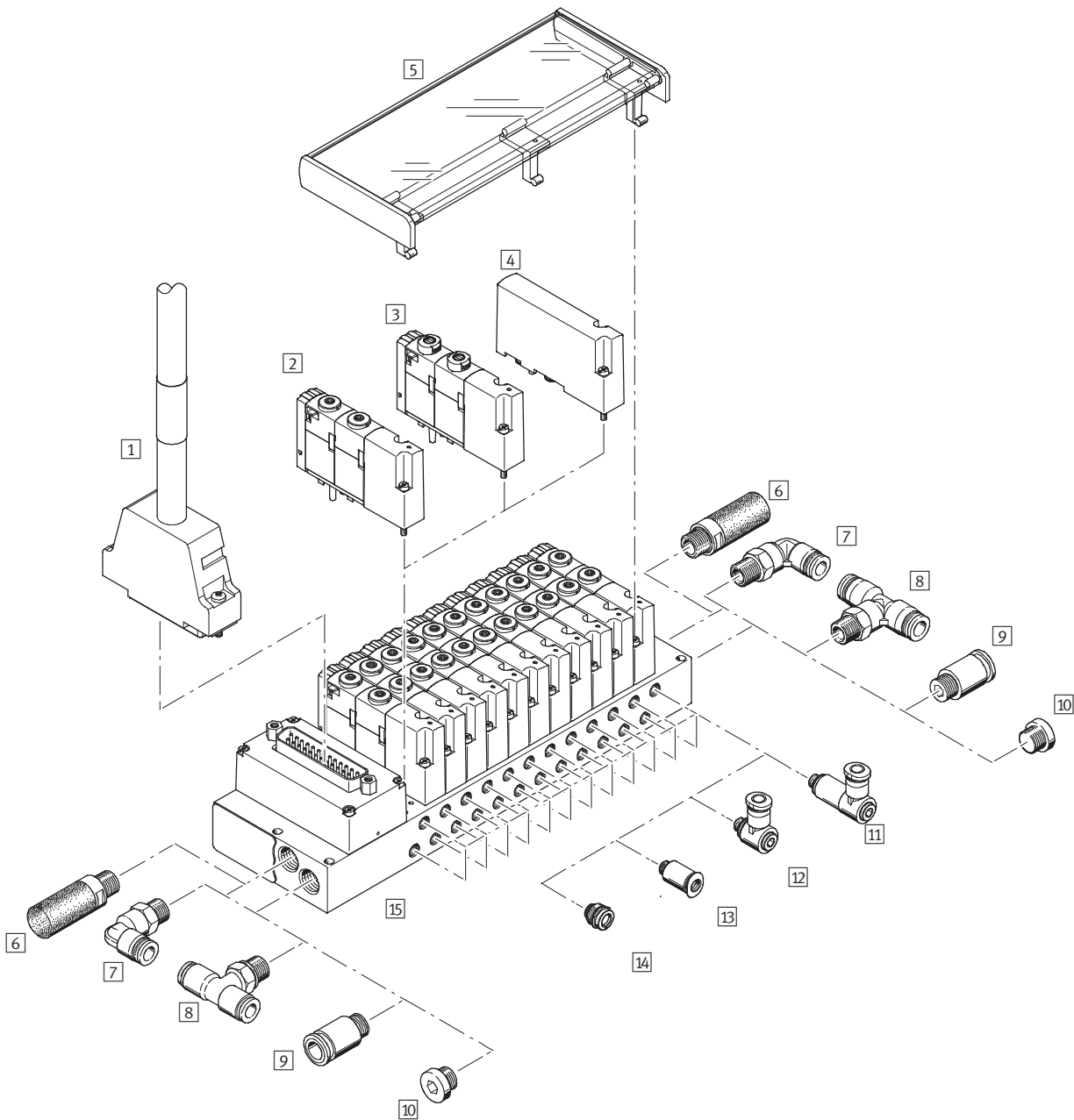

Valve terminals type 84 VTOC

Peripherals overview

Accessories				
	Type	Brief description	→ Page/ Internet	
1	Connecting cable	KMP6	Connecting cable for multi-pin plug connection, with Sub-D plug, 25-pin	26
2	Single solenoid valve	VOVC	Solenoid valve with non-detenting manual override	26
3	Single solenoid valve	VOVC	Solenoid valve with detenting, non-detenting manual override	26
4	Blanking plate	VABB	Blanking plate for vacant position	26
5	Inscription label holder	ASCF	For labelling the valves/manual override cover	26
6	Silencer	U	For fitting in exhaust ports	27
7	Push-in L-fitting	QSL	For connecting to the air supply or exhaust	27
8	T-fitting	QST	For connecting to the air supply or exhaust	27
9	Straight fitting	OS	For connecting to the air supply or exhaust	27
10	Blanking plug	B	For sealing the port for the air supply or exhaust	26
11	Push-in L-fitting, long	QSMLLV	Long elbow connector for working lines	27
12	Push-in L-fitting	QSMLV	Elbow connector for working lines	27
13	Push-in fitting	QS	Straight push-in fitting for working lines	27
14	Push-in fitting	QSIMG	Straight countersunk push-in fitting for working lines (compact)	–
15	Manifold rail	VABB	With multi-pin plug connection for max. 24 valve positions	–

Valve terminals type 84 VTOC

Peripherals overview

FESTO

Flat cable	Number of valve positions	Pin allocation variants									
		Top left (LT)				Bottom left (LB)		Top right (RT)			
		26 pins, 1-way	26 pins, 2-way	50 pins, 1-way	50 pins, 2-way	26 pins, 1-way	26 pins, 2-way	40 pins, 1-way	40 pins, 2-way	50 pins, 1-way	50 pins, 2-way
	4-12	V14	-	-	-	V8	-	-	-	-	-
	8-12	-	-	V11 ¹⁾	-	-	-	-	-	V10 ¹⁾	-
	6-10	-	-	-	-	-	-	V9 ¹⁾²⁾	-	-	-
	13-24	-	V15	-	-	-	V17	-	-	-	-
	16-24	-	-	-	V16 ¹⁾	-	-	-	-	-	-
	16-20	-	-	-	-	-	-	-	V18 ¹⁾²⁾	-	-
	18-24	-	-	-	-	-	-	-	-	-	V19 ¹⁾

- 1) Individual ground
- 2) Not bi-directional

Overview of electrical connections

Valve terminal with flat cable connection on top

- Flat cable connection type, code: RC
 - Connection direction:
 - Top left (code LT)
 - Top right (code RT)
- A total of 10 pin allocation variants are available. Detailed pin allocation → p. 16

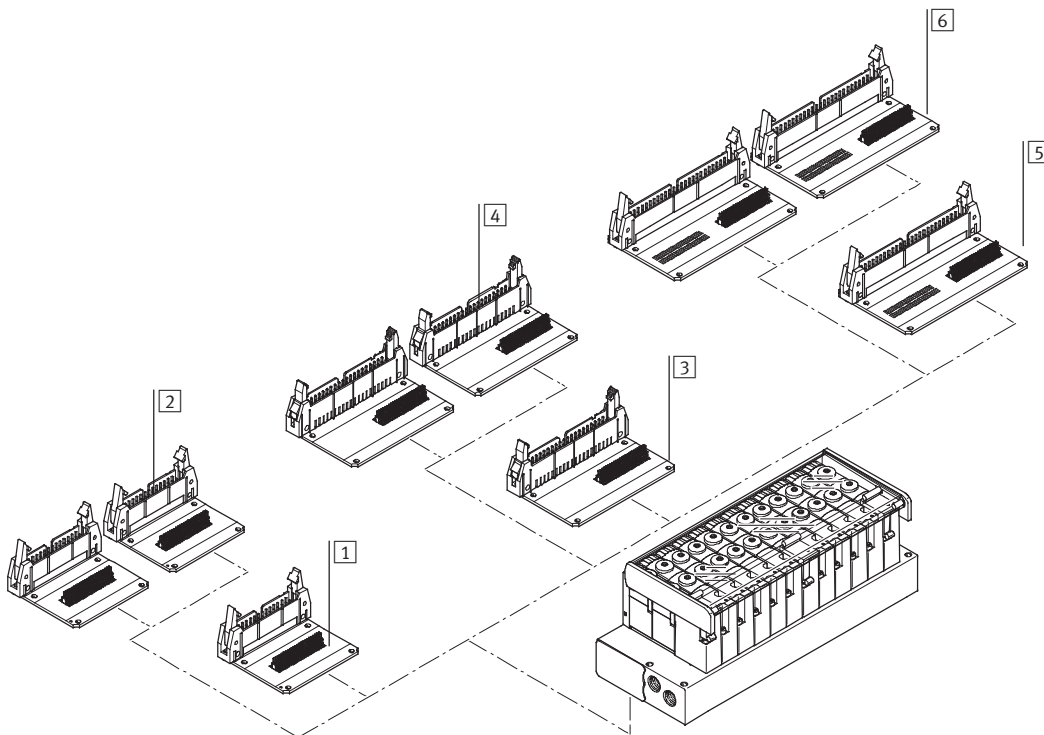

Accessories					
	Code	Brief description	Number of valve positions	Variants	
1	LT	Flat cable, 26-pin 1-way, top left	4-12	V14	
2	LT	Flat cable, 26-pin 2-way, top left	13-24	V15	
3	RT	Flat cable, 40-pin 1-way, top right	6-10	V9	
4	RT	Flat cable, 40-pin 2-way, top right	16-20	V18	
5	RT	Flat cable, 50-pin 1-way, top right	8-12	V10	
6	RT	Flat cable, 50-pin 2-way, top right	18-24	V19	
5	LT	Flat cable, 50-pin 1-way, top left	8-12	V11	
6	LT	Flat cable, 50-pin 2-way, top left	16-24	V16	

Valve terminals type 84 VTOC

Peripherals overview

Overview of electrical connections

Valve terminal with flat cable connection underneath

- Flat cable connection type, code: RC
 - Connection direction:
 - Bottom left (code LB)
- A total of 10 pin allocation variants are available.
- Detailed pin allocation → p. 16

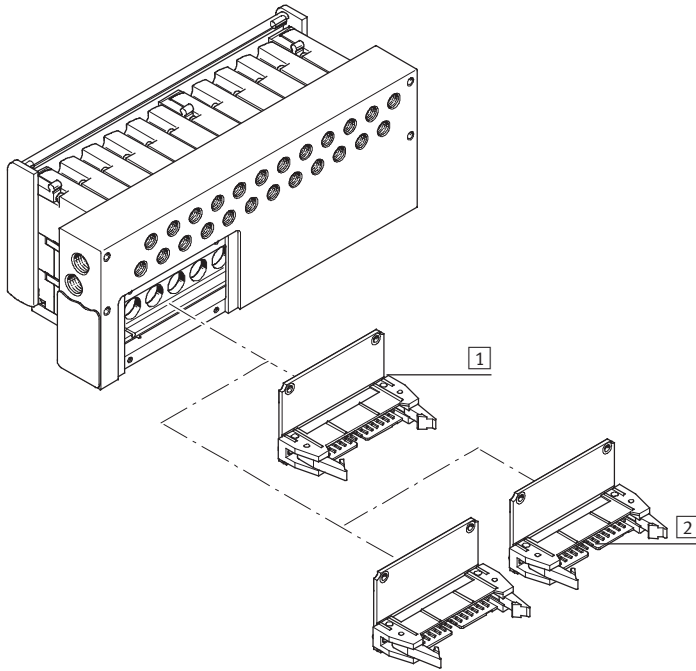

Accessories				
	Code	Brief description	Number of valve positions	Variants
1	LB	1-way, bottom left	4–12	V8
2		2-way, bottom left	13–24	V17

Valve terminals type 84 VTOC

Peripherals overview

Sub-D	Number of valve positions	Pin allocation variants									
		Top left (LT)								Top right (RT)	
		25 pins, 1-way			25 pins, 2-way	25 pins, 2-way	44 pins, 1-way	44 pins, 2-way		44 pins, 1-way	
	2-12	V2	V3 ²⁾	V1	-	-	-	-	-	-	-
	4-12	-	-	-	-	V12 ¹⁾	-	-	-	-	-
	13-21	-	-	-	-	-	V5	-	-	V13	-
	13-22	-	-	-	-	-	-	V7 ¹⁾	V6 ¹⁾²⁾	-	-
	13-24	-	-	-	V4	-	-	-	-	-	-

- 1) Individual ground
- 2) Not bi-directional

Overview of electrical connections

Valve terminal with Sub-D connection on top

- Sub-D connection type, code: SD

Connection direction:

- Top left (code LT)
- Top right (code RT)

A total of 9 pin allocation variants are available.

Detailed pin allocation → p. 14

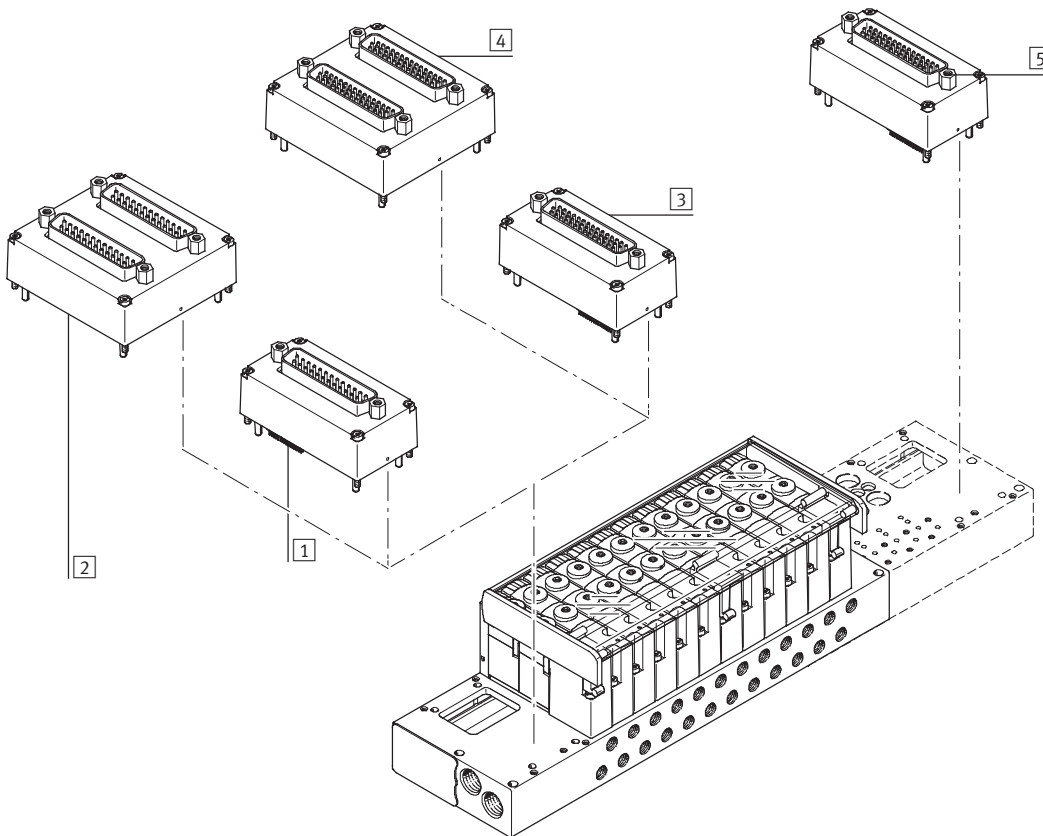

Accessories					
	Code	Brief description	Number of valve positions	Variants	
1	Sub-D, 25-pin	LT	1-way, top left	2...12	V1, V2, V3
2	Sub-D, 25-pin		2-way, top left	13...24	V4
				4...12	V12
3	Sub-D, 44-pin	LT	1-way, top left	13...21	V5
4	Sub-D, 44-pin		2-way, top left	13...22	V6, V7
5	Sub-D, 44-pin	RT	1-way, top right	13...20	V13

Valve terminals type 84 VTOC

Key features – Pneumatic components

Design

The valves are mounted on the metal manifold rail using two screws. The use of 2x3/2 directional control valves per valve position guarantees optimum use of space with maximum performance. The valves only differ in

the type of manual override. The assembled and tested units or individual components as modules enable a custom configuration.

Blanking plates can be replaced by valves at a later date. The dimensions, mounting points and existing

pneumatic and electrical installations remain unchanged during this process.

Valve function

Code	Circuit symbol	Width	Description
		10 mm	
K		■	2x3/2-way valve, single solenoid <ul style="list-style-type: none"> • Mechanical spring return • Non-reversible

Valve terminals type 84 VTOC

Key features – Pneumatic components

Fittings

Port 1/3

Wide range of connection sizes:

- Threaded connection M7, G $\frac{1}{8}$, $\frac{1}{8}$ NPT
- Push-in connector QS-6-, QS-8, QS- $\frac{3}{8}$ or QS- $\frac{1}{4}$ (compressed air supply)
- Push-in connector QS6, QS- $\frac{1}{4}$ or silencer (exhaust air)

Variable connection types for port 1, compressed air supply and port 3, exhaust air:

- Straight
- Push-in L-fitting
- T-fitting

Flexible connection positions for the compressed air supply and exhaust:

- Both sides
- Left-hand
- Right-hand

Port 1/3

Connection direction: front

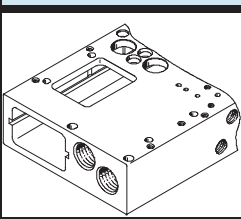

Code

Description

-G18

Manifold block G $\frac{1}{8}$
(diagram shows example of Sub-D electrical connection on left)
Basis for design:

- Push-in connector QS8
- Push-in connector QS- $\frac{3}{8}$ "

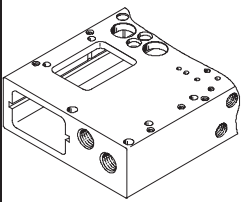

-M7

Manifold block M7
(diagram shows example of Sub-D electrical connection on left)
Basis for design:

- Push-in connector QS6
- Push-in connector QS- $\frac{1}{4}$ "
- Exhaust port via push-in fitting or silencer

Valve terminals type 84 VTOC

Key features – Pneumatic components

Fittings

Port 2/4

Wide range of connection sizes:

- Threaded connection M5
- 10-32 UNF
- Push-in connector QS-3, QS-4 or 1/8"

Outlet direction:

- Front
- Underneath

Connection on the valve (port 2/4)

Outlet direction to the front

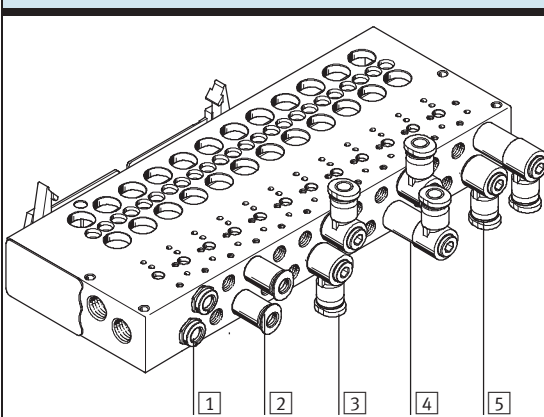

	Code	Description
1	X	Straight countersunk outlet (compact)
2	-	Straight outlet
3	FB	Angled output, upwards/downwards
4	FA	Angled outlet, upwards
5	FC	Angled outlet, downwards

Outlet direction underneath

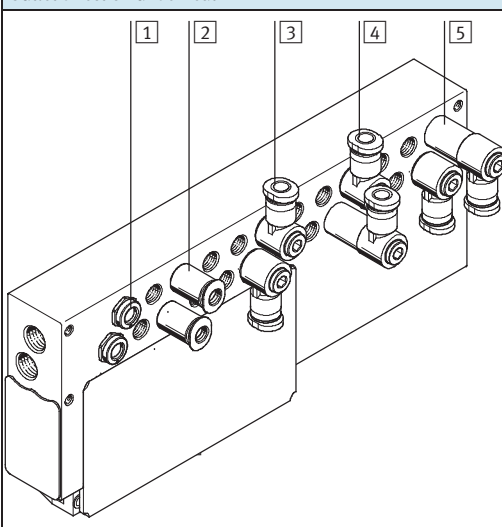

1	X	Straight countersunk outlet (compact)
2	U	Straight outlet
3	UB	Angled outlet, to the front/rear
4	UA	Angled outlet, to the front
5	UC	Angled outlet, to the rear

Valve terminals type 84 VTOC

Key features – Display and operation

Manual override (MO)

Manual override with automatic return (non-detenting)

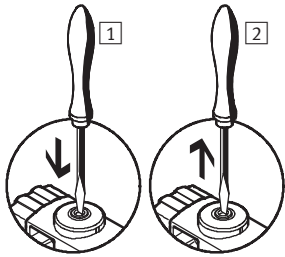

1 Press in the stem of the manual override with a pointed object or screwdriver.
The valve switches.

2 Remove the pointed object or screwdriver.
Spring force pushes the manual override back.
Valve returns to normal position.

Manual override with lock (non-detenting/detenting)

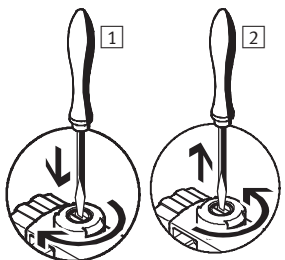

1 Press in the stem of the manual override with a screwdriver until the valve switches and then turn the stem clockwise by 90° until the stop is reached.
The valve remains switched.

2 Turn the stem anti-clockwise by 90° until the stop is reached and then remove the screwdriver.
Spring force pushes the manual override back.
Valve returns to normal position.

Note

VTOC provides two valves with the same valve function but different types of manual override. There is no provision for subsequent modification of the type of manual override (e.g. by attaching a cover).

Identification system

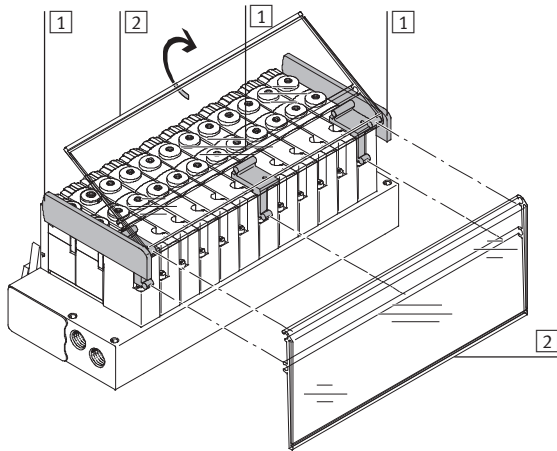

1 Retainer for inscription label holder
The retainer for the inscription label holder is fastened to the valves with one screw and enables the inscription label holder to be mounted in two different directions. The retainers at the side are flanged to prevent the inscription label sliding out.

2 Inscription label holder
A transparent inscription label holder ASCF-H-L2 (code F/T in the order code) can be mounted for labelling the valves.
Inscription labels can be inserted in the holders for labelling purposes. Templates for printing the inscription label are available on request.

Mounting – Valve terminal

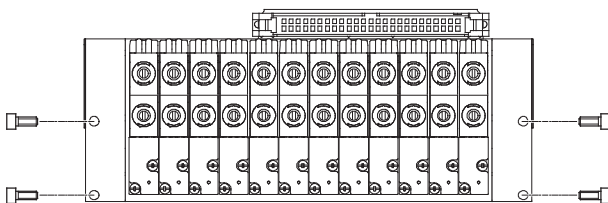

Sturdy terminal mounting thanks to:

- Four through-holes for wall mounting (hole \varnothing : 3.3 mm)
- Four holes with thread on the reverse side:
 - Thread M3
 - Thread M4

- Thread 8-32 UNC
- Thread 10-32 UNC-2B

Valve terminals type 84 VTOC

Key features – Electrical components

Electrical multi-pin plug connection

The following multi-pin plug connections are available for the valve terminal VTOC:

- Sub-D multi-pin plug connection (25-pin, 1-way or 2-way)
- Sub-D multi-pin plug connection (44-pin, 1-way or 2-way)
- Flat cable plug (26-pin, 1-way or 2-way)
- Flat cable plug (40-pin, 1-way or 2-way)
- Flat cable plug (50-pin, 1-way or 2-way)

Connection directions:

- Sub-D connection (top left/right)
- Flat cable (top/bottom left, top/bottom right)

Control signals from the controller to the valve terminal are transmitted via the multi-core pre-assembled cable, which substantially reduces installation time.

The valves are switched by means of positive or negative logic (positive switching or negative switching). Mixed operation is not permitted. Each pin on the multi-pin plug can actuate exactly one solenoid coil. If the maximum configurable number of valve positions is 24, then

48 valves can be addressed with one solenoid coil (single solenoid). The multi-pin plug connection is available with 19 different pin allocation variants. Other variants on request.

Explanation of pin allocation (V12)

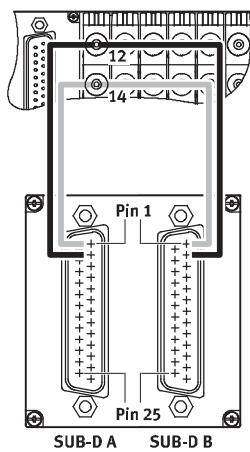

The example shows the pin allocation code V12. The solenoid coils are wired in ascending order of the valves so that solenoid coil 14 occupies the low-value pin and solenoid coil 12 the next pin of both Sub-D connections:

- Pin 1 of Sub-D A and Sub-D B at valve position 1, coil 14.
 - Pin 2 of Sub-D A and Sub-D B at valve position 1, coil 12.
- The following tables show the different pin allocation variants.

The circuitry may differ from the example depending on the multi-pin plug connection chosen.

Valve terminals type 84 VTOC

Key features – Electrical components



Pin allocation – Sub-D plug, 25-pin

	Pin	-V2		-V3		-V1		-V4				-V12				
		Sub-D A ¹⁾	Sub-D B ²⁾	Sub-D A ¹⁾	Sub-D B ²⁾	Sub-D A ¹⁾	Sub-D B ²⁾	Sub-D A ¹⁾	Sub-D B ²⁾	Sub-D A ¹⁾	Sub-D B ²⁾	Sub-D A ¹⁾	Sub-D B ²⁾			
	1	VP1	14	VP1	14-	VP1	12	VP1	14	VP13	14	VP1	14	VP1	14	
	2	VP2	14	VP2	14-	VP1	14	VP1	12	VP13	12	VP1	12	VP1	12	
	3	VP3	14	VP3	14-	VP2	12	VP2	14	VP14	14	VP2	14	VP2	14	
	4	VP4	14	VP4	14-	VP2	14	VP2	12	VP14	12	VP2	12	VP2	12	
	5	VP5	14	VP5	14-	VP3	12	VP3	14	VP15	14	VP3	14	VP3	14	
	6	VP6	14	VP6	14-	VP3	14	VP3	12	VP15	12	VP3	12	VP3	12	
	7	VP7	14	VP7	14-	VP4	12	VP4	14	VP16	14	VP4	14	VP4	14	
	8	VP8	14	VP8	14-	VP4	14	VP4	12	VP16	12	VP4	12	VP4	12	
	9	VP9	14	VP9	14-	VP5	12	VP5	14	VP17	14	VP5	14	VP5	14	
	10	VP10	14	VP10	14-	VP5	14	VP5	12	VP17	12	VP5	12	VP5	12	
	11	VP11	14	VP11	14-	VP6	12	VP6	14	VP18	14	VP6	14	VP6	14	
	12	VP12	14	VP12	14-	VP6	14	VP6	12	VP18	12	VP6	12	VP6	12	
	13	Com	Com+		VP7	12	VP7	14	VP19	14	VP7	14	VP7	14	VP7	14
	14	VP1	12	VP1	12-	VP7	14	VP7	12	VP19	12	VP7	12	VP7	12	
	15	VP2	12	VP2	12-	VP8	12	VP8	14	VP20	14	VP8	14	VP8	14	
	16	VP3	12	VP3	12-	VP8	14	VP8	12	VP20	12	VP8	12	VP8	12	
	17	VP4	12	VP4	12-	VP9	12	VP9	14	VP21	14	VP9	14	VP9	14	
	18	VP5	12	VP5	12-	VP9	14	VP9	12	VP21	12	VP9	12	VP9	12	
	19	VP6	12	VP6	12-	VP10	12	VP10	14	VP22	14	VP10	14	VP10	14	
	20	VP7	12	VP7	12-	VP10	14	VP10	12	VP22	12	VP10	12	VP10	12	
Note The drawing shows the view onto the Sub-D plug on the valve terminal.	21	VP8	12	VP8	12-	VP11	12	VP11	14	VP23	14	VP11	14	VP11	14	
	22	VP9	12	VP9	12-	VP11	14	VP11	12	VP23	12	VP11	12	VP11	12	
	23	VP10	12	VP10	12-	VP12	12	VP12	14	VP24	14	VP12	14	VP12	14	
	24	VP11	12	VP11	12-	VP12	14	VP12	12	VP24	12	VP12	12	VP12	12	
	25	VP12	12	VP12	12-	Com		Com 1-12		Com 13-24		-		-		

VP Valve position

- 1) Sub-D A, first Sub-D plug
- 2) Sub-D B, second Sub-D plug

Example of pin allocation V12

V12

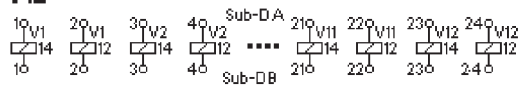

Valve terminals type 84 VTOC

Key features – Electrical components

Pin allocation – Sub-D plug, 44-pin													
Pin	-V5		-V7				-V6				-V13		
			Sub-D A ¹⁾		Sub-D B ²⁾		Sub-D A ¹⁾		Sub-D B ²⁾				
1	VP1	14	VP1	14	VP1	14	VP1	14+	VP1	14-	VP1	12	
2	VP1	12	VP1	12	VP1	12	VP1	12+	VP1	12-	VP1	14	
3	VP2	14	VP2	14	VP2	14	VP2	14+	VP2	14-	VP2	12	
4	VP2	12	VP2	12	VP2	12	VP2	12+	VP2	12-	VP2	14	
5	VP3	14	VP3	14	VP3	14	VP3	14+	VP3	14-	VP3	12	
6	VP3	12	VP3	12	VP3	12	VP3	12+	VP3	12-	VP3	14	
7	VP4	14	VP4	14	VP4	14	VP4	14+	VP4	14-	VP4	12	
8	VP4	12	VP4	12	VP4	12	VP4	12+	VP4	12-	VP4	14	
9	VP5	14	VP5	14	VP5	14	VP5	14+	VP5	14-	VP5	12	
10	VP5	12	VP5	12	VP5	12	VP5	12+	VP5	12-	VP5	14	
11	VP6	14	VP6	14	VP6	14	VP6	14+	VP6	14-	VP6	12	
12	VP6	12	VP6	12	VP6	12	VP6	12+	VP6	12-	VP6	14	
13	VP7	14	VP7	14	VP7	14	VP7	14+	VP7	14-	VP7	12	
14	VP7	12	VP7	12	VP7	12	VP7	12+	VP7	12-	VP7	14	
15	VP8	14	VP8	14	VP8	14	VP8	14+	VP8	14-	VP8	12	
16	VP8	12	VP8	12	VP8	12	VP8	12+	VP8	12-	VP8	14	
17	VP9	14	VP9	14	VP9	14	VP9	14+	VP9	14-	VP9	12	
18	VP9	12	VP9	12	VP9	12	VP9	12+	VP9	12-	VP9	14	
19	VP10	14	VP10	14	VP10	14	VP10	14+	VP10	14-	VP10	12	
20	VP10	12	VP10	12	VP10	12	VP10	12+	VP10	12-	VP10	14	
21	VP11	14	VP11	14	VP11	14	VP11	14+	VP11	14-	VP11	12	
22	VP11	12	VP11	12	VP11	12	VP11	12+	VP11	12-	VP11	14	
23	VP12	14	VP12	14	VP12	14	VP12	14+	VP12	14-	VP12	12	
24	VP12	12	VP12	12	VP12	12	VP12	12+	VP12	12-	VP12	14	
25	VP13	14	VP13	14	VP13	14	VP13	14+	VP13	14-	VP13	12	
26	VP13	12	VP13	12	VP13	12	VP13	12+	VP13	12-	VP13	14	
27	VP14	14	VP14	14	VP14	14	VP14	14+	VP14	14-	VP14	12	
28	VP14	12	VP14	12	VP14	12	VP14	12+	VP14	12-	VP14	14	
29	VP15	14	VP15	14	VP15	14	VP15	14+	VP15	14-	VP15	12	
30	VP15	12	VP15	12	VP15	12	VP15	12+	VP15	12-	VP15	14	
31	VP16	14	VP16	14	VP16	14	VP16	14+	VP16	14-	VP16	12	
32	VP16	12	VP16	12	VP16	12	VP16	12+	VP16	12-	VP16	14	
33	VP17	14	VP17	14	VP17	14	VP17	14+	VP17	14-	VP17	12	
34	VP17	12	VP17	12	VP17	12	VP17	12+	VP17	12-	VP17	14	
35	VP18	14	VP18	14	VP18	14	VP18	14+	VP18	14-	VP18	12	
36	VP18	12	VP18	12	VP18	12	VP18	12+	VP18	12-	VP18	14	
37	VP19	14	VP19	14	VP19	14	VP19	14+	VP19	14-	VP19	12	
38	VP19	12	VP19	12	VP19	12	VP19	12+	VP19	12-	VP19	14	
39	VP20	14	VP20	14	VP20	14	VP20	14+	VP20	14-	VP20	12	
40	VP20	12	VP20	12	VP20	12	VP20	12+	VP20	12-	VP20	14	
41	VP21	14	VP21	14	VP21	14	VP21	14+	VP21	14-	Com		
42	VP21	12	VP21	12	VP21	12	VP21	12+	VP21	12-	Com		
43	Com		VP22	14	VP22	14	VP22	14+	VP22	14-	Com		
44	Com		VP22	12	VP22	12	VP22	12+	VP22	12-	Com		

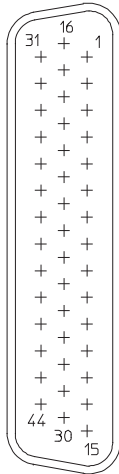

VP Valve position
 1) Sub-D A, first Sub-D plug
 2) Sub-D B, second Sub-D plug

Valve terminals type 84 VTOC

Key features – Electrical components



Pin allocation – Flat cable, 26-pin													
Pin	-V14		-V15				-V8		-V17				
			Plug 1		Plug 2				Plug 1		Plug 2		
	1	VP1	14	VP1	14	VP13	14	VP1	14	VP12	14	VP24	14
	2	VP1	12	VP1	12	VP13	12	VP1	12	VP12	12	VP24	12
	3	VP2	14	VP2	14	VP14	14	VP2	14	VP11	14	VP23	14
	4	VP2	12	VP2	12	VP14	12	VP2	12	VP11	12	VP23	12
	5	VP3	14	VP3	14	VP15	14	VP3	14	VP10	14	VP22	14
	6	VP3	12	VP3	12	VP15	12	VP3	12	VP10	12	VP22	12
	7	VP4	14	VP4	14	VP16	14	VP4	14	VP9	14	VP21	14
	8	VP4	12	VP4	12	VP16	12	VP4	12	VP9	12	VP21	12
	9	VP5	14	VP5	14	VP17	14	VP5	14	VP8	14	VP20	14
	10	VP5	12	VP5	12	VP17	12	VP5	12	VP8	12	VP20	12
	11	VP6	14	VP6	14	VP18	14	VP6	14	VP7	14	VP19	14
	12	VP6	12	VP6	12	VP18	12	VP6	12	VP7	12	VP19	12
	13	VP7	14	VP7	14	VP19	14	VP7	14	VP6	14	VP18	14
	14	VP7	12	VP7	12	VP19	12	VP7	12	VP6	12	VP18	12
	15	VP8	14	VP8	14	VP20	14	VP8	14	VP5	14	VP17	14
	16	VP8	12	VP8	12	VP20	12	VP8	12	VP5	12	VP17	12
	17	VP9	14	VP9	14	VP21	14	VP9	14	VP4	14	VP16	14
	18	VP9	12	VP9	12	VP21	12	VP9	12	VP4	12	VP16	12
	19	VP10	14	VP10	14	VP22	14	VP10	14	VP3	14	VP15	14
	20	VP10	14	VP10	14	VP22	12	VP10	14	VP3	12	VP15	12
	21	VP11	14	VP11	14	VP23	14	VP11	14	VP2	14	VP14	14
	22	VP11	12	VP21	12	VP23	12	VP11	12	VP2	12	VP14	12
	23	VP12	14	VP12	14	VP24	14	VP12	14	VP1	14	VP13	14
	24	VP12	12	VP12	12	VP24	12	VP12	12	VP1	12	VP13	12
25	Com		Com		Com		Com		Com		Com		
26	Com		Com		Com		Com		Com		Com		

Note

The drawing shows the view onto the flat cable plug on the valve terminal.

VP Valve position

Valve terminals type 84 VTOC

Key features – Electrical components



Pin allocation – Flat cable, 40-pin								
	Pin	-V9		-V18				
				Plug 1		Plug 2		
	1	VP10	12+	VP10	12+	VP11	14+	
	2	VP10	12-	VP10	12-	VP11	14-	
	3	VP10	14+	VP10	14+	VP11	12+	
	4	VP10	14-	VP10	14-	VP11	12-	
	5	VP9	12+	VP9	12+	VP12	14+	
	6	VP9	12-	VP9	12-	VP12	14-	
	7	VP9	14+	VP9	14+	VP12	12+	
	8	VP9	14-	VP9	14-	VP12	12-	
	9	VP8	12+	VP8	12+	VP13	14+	
	10	VP8	12-	VP8	12-	VP13	14-	
	11	VP8	14+	VP8	14+	VP13	12+	
	12	VP8	14-	VP8	14-	VP13	12-	
	13	VP7	12+	VP7	12+	VP14	14+	
	14	VP7	12-	VP7	12-	VP14	14-	
	15	VP7	14+	VP7	14+	VP14	12+	
	16	VP7	14-	VP7	14-	VP14	12-	
	17	VP6	12+	VP6	12+	VP15	14+	
	18	VP6	12-	VP6	12-	VP15	14-	
	19	VP6	14+	VP6	14+	VP15	12+	
	20	VP6	14-	VP6	14-	VP15	12-	
	21	VP5	12+	VP5	12+	VP16	14+	
	22	VP5	12-	VP5	12-	VP16	14-	
	23	VP5	14+	VP5	14+	VP16	12+	
	24	VP5	14-	VP5	14-	VP16	12-	
	25	VP4	12+	VP4	12+	VP17	14+	
	26	VP4	12-	VP4	12-	VP17	14-	
	27	VP4	14+	VP4	14+	VP17	12+	
	28	VP4	14-	VP4	14-	VP17	12-	
	29	VP3	12+	VP3	12+	VP18	14+	
	30	VP3	12-	VP3	12-	VP18	14-	
	31	VP3	14+	VP3	14+	VP18	12+	
	32	VP3	14-	VP3	14-	VP18	12-	
	33	VP2	12+	VP2	12+	VP19	14+	
	34	VP2	12-	VP2	12-	VP19	14-	
	35	VP2	14+	VP2	14+	VP19	12+	
	36	VP2	14-	VP2	14-	VP19	12-	
	Note The drawing shows the view onto the flat cable plug on the valve terminal.	37	VP1	12+	VP1	12+	VP20	14+
		38	VP1	12-	VP1	12-	VP20	14-
		39	VP1	14+	VP1	14+	VP20	12+
		40	VP1	14-	VP1	14-	VP20	12-

VP Valve position

Example of pin allocation V18

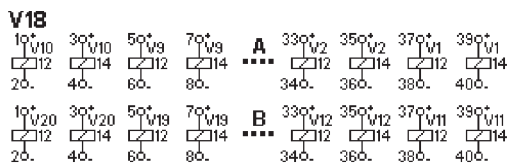

Valve terminals type 84 VTOC

Key features – Electrical components

Pin allocation – Flat cable, 50-pin												
Pin	-V11		-V16				-V10		-V19			
			Plug 1		Plug 2				Plug 1		Plug 2	
1	VP1	12	VP1	12	VP24	12	VP12	12	VP12	12	VP13	12
2	VP1	12	VP1	12	VP24	12	VP12	12	VP12	12	VP13	12
3	VP1	14	VP1	14	VP24	14	VP12	14	VP12	14	VP13	14
4	VP1	14	VP1	14	VP24	14	VP12	14	VP12	14	VP13	14
5	VP2	12	VP2	12	VP23	12	VP11	12	VP11	12	VP14	12
6	VP2	12	VP2	12	VP23	12	VP11	12	VP11	12	VP14	12
7	VP2	14	VP2	14	VP23	14	VP11	14	VP11	14	VP14	14
8	VP2	14	VP2	14	VP23	14	VP11	14	VP11	14	VP14	14
9	VP3	12	VP3	12	VP22	12	VP10	12	VP10	12	VP15	12
10	VP3	12	VP3	12	VP22	12	VP10	12	VP10	12	VP15	12
11	VP3	14	VP3	14	VP22	14	VP10	14	VP10	14	VP15	14
12	VP3	14	VP3	14	VP22	14	VP10	14	VP10	14	VP15	14
13	VP4	12	VP4	12	VP21	12	VP9	12	VP9	12	VP16	12
14	VP4	12	VP4	12	VP21	12	VP9	12	VP9	12	VP16	12
15	VP4	14	VP4	14	VP21	14	VP9	14	VP9	14	VP16	14
16	VP4	14	VP4	14	VP21	14	VP9	14	VP9	14	VP16	14
17	VP5	12	VP5	12	VP20	12	VP8	12	VP8	12	VP17	12
18	VP5	12	VP5	12	VP20	12	VP8	12	VP8	12	VP17	12
19	VP5	14	VP5	14	VP20	14	VP8	14	VP8	14	VP17	14
20	VP5	14	VP5	14	VP20	14	VP8	14	VP8	14	VP17	14
21	VP6	12	VP6	12	VP19	12	VP7	12	VP7	12	VP18	12
22	VP6	12	VP6	12	VP19	12	VP7	12	VP7	12	VP18	12
23	VP6	14	VP6	14	VP19	14	VP7	14	VP7	14	VP18	14
24	VP6	14	VP6	14	VP19	14	VP7	14	VP7	14	VP18	14
25	VP7	12	VP7	12	VP18	12	VP6	12	VP6	12	VP19	12
26	VP7	12	VP7	12	VP18	12	VP6	12	VP6	12	VP19	12
27	VP7	14	VP7	14	VP18	14	VP6	14	VP6	14	VP19	14
28	VP7	14	VP7	14	VP18	14	VP6	14	VP6	14	VP19	14
29	VP8	12	VP8	12	VP17	12	VP5	12	VP5	12	VP20	12
30	VP8	12	VP8	12	VP17	12	VP5	12	VP5	12	VP20	12
31	VP8	14	VP8	14	VP17	14	VP5	14	VP5	14	VP20	14
32	VP8	14	VP8	14	VP17	14	VP5	14	VP5	14	VP20	14
33	VP9	12	VP9	12	VP16	12	VP4	12	VP4	12	VP21	12
34	VP9	12	VP9	12	VP16	12	VP4	12	VP4	12	VP21	12
35	VP9	14	VP9	14	VP16	14	VP4	14	VP4	14	VP21	14
36	VP9	14	VP9	14	VP16	14	VP4	14	VP4	14	VP21	14
37	VP10	12	VP10	12	VP15	12	VP3	12	VP3	12	VP22	12
38	VP10	12	VP10	12	VP15	12	VP3	12	VP3	12	VP22	12
39	VP10	14	VP10	14	VP15	14	VP3	14	VP3	14	VP22	14
40	VP10	14	VP10	14	VP15	14	VP3	14	VP3	14	VP22	14
41	VP11	12	VP11	12	VP14	12	VP2	12	VP2	12	VP23	12
42	VP11	12	VP11	12	VP14	12	VP2	12	VP2	12	VP23	12
43	VP11	14	VP11	14	VP14	14	VP2	14	VP2	14	VP23	14
44	VP11	14	VP11	14	VP14	14	VP2	14	VP2	14	VP23	14
45	VP12	12	VP12	12	VP13	12	VP1	12	VP1	12	VP24	12
46	VP12	12	VP12	12	VP13	12	VP1	12	VP1	12	VP24	12
47	VP12	14	VP12	14	VP13	14	VP1	14	VP1	14	VP24	14
48	VP12	14	VP12	14	VP13	14	VP1	14	VP1	14	VP24	14
49	–	–	–	–	–	–	–	–	–	–	–	–
50	–	–	–	–	–	–	–	–	–	–	–	–

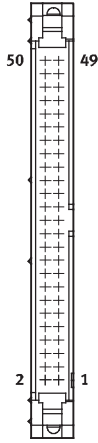

Note

The drawing shows the view onto the flat cable plug on the valve terminal.

VP Valve position

Valve terminals type 84 VTOC

Technical data

Voltage

24 V DC

Pressure

0 ... +8 bar

Temperature range

-5 ... +50 °C

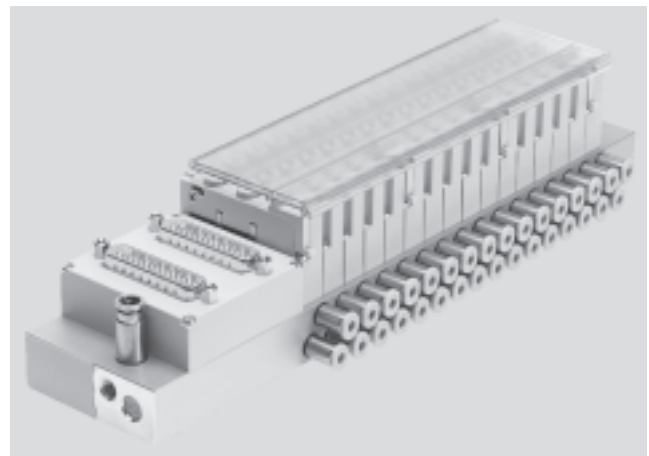

General technical data			
Valve function			2x3/2-way valve, single solenoid, closed
Design			Poppet valve with spring return
Sealing principle			Soft
Actuation type			Electrical
Reset method			Mechanical spring
Type of control			Direct
Direction of flow			Non-reversible
Exhaust function			No flow control
Manual override			Non-detenting, detenting and non-detenting
Type of mounting			Via through-hole or thread
Width	[mm]		10
Nominal size	[mm]		0.65
Max. number of valve positions			24
Standard nominal flow rate	qnN	[l/min]	10

Operating and environmental conditions			
Operating medium			Dried and filtered compressed air, lubricated or unlubricated, grade of filtration 40 µm
Operating pressure	[bar]		0 ... +8
Ambient temperature	[°C]		-5 ... +50
Temperature of medium	[°C]		+5 ... +50
Note on materials			RoHS-compliant

Product weight	
Approx. weight	[g]
Valve	30
Blanking plate for vacant position	20

Electrical data		
Electrical actuation		Multi-pin plug (Sub-D/flat cable)
Nominal operating voltage	[V DC]	24
Permissible voltage fluctuations	[%]	±10
Protection class to EN 60529		IP40
Duty cycle	[%]	100

Valve switching times	
	[ms]
On	4.7
Off	5.2

Valve terminals type 84 VTOC

Technical data

FESTO

Dimensions – Sub-D, single or double

Download CAD data → www.festo.com

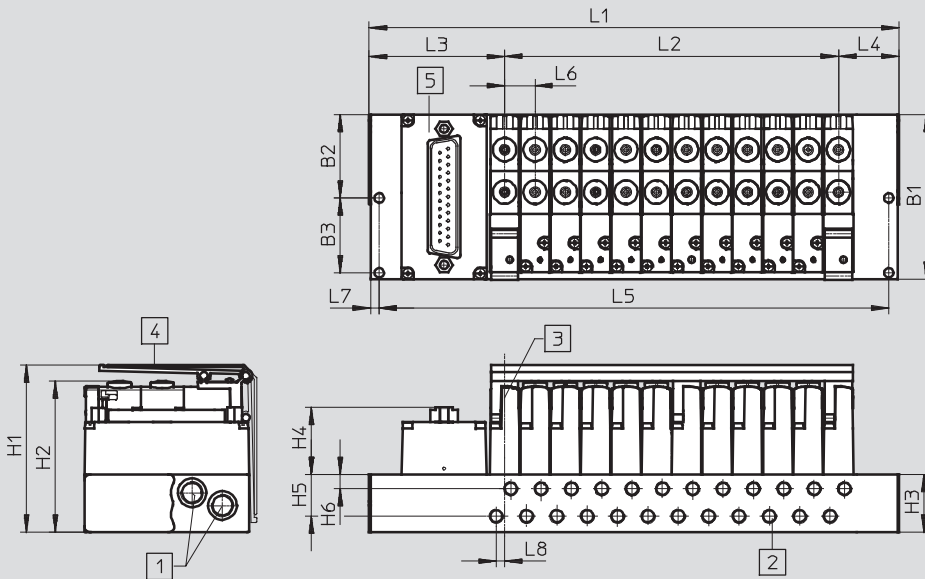

- 1 Ports 1 and 3, left and right, M7 or G1/8
- 2 Ports 2 and 4, front or underneath, M5 or 10-32 UNF
- 3 Centre of first valve position
- 4 Inscription label
- 5 Electrical connection via Sub-D, single or double (left or right)

	Comment	Electrical connection on top, single			Electrical connection on top, double		
Pneumatic connection	–	M7	G1/8	G1/8	M7	G1/8	G1/8
Through-hole	–	∅ 3.3	∅ 3.3	M4	∅ 3.3	∅ 3.3	M4
L1	–	L2+L3+L4	L2+L3+L4	L2+L3+L4	L2+L3+L4	L2+L3+L4	L2+L3+L4
L2	–	(n-1)x10.5	(n-1)x10.5	(n-1)x10.5	(n-1)x10.5	(n-1)x10.5	(n-1)x10.5
L3	Distance from centre of first valve position to outer edge on left-hand side	41.4	46.4	36.9	66.4	71.4	66.4
	Sub-D connection, 44-pin, top right, 1-way: Distance from centre of first valve position to outer edge on left-hand side	14.4	20.4	20.4	–	–	–
L4	Distance from centre of last valve position to outer edge on right-hand side	14.4	20.4	20.4	–	–	–
	Sub-D connection, 44-pin, top right, 1-way: Distance from centre of last valve position to outer edge on right-hand side	41.4	46.4	36.9	–	–	–
L5	–	(L1-6)	(L1-6)	(L1-6)	(L1-6)	(L1-6)	(L1-6)

B1	B2 ± 0.1	B3 ± 0.1	H1	H2	H3	H4	H5	H6	L6	L7 ± 0.1	L8
57	28.9	25.9	57.9	52.3	20	23.1	14.5	5	10.5	3	2.9

Valve terminals type 84 VTOC

Technical data

Dimensions – Flat cable on top

Download CAD data → www.festo.com

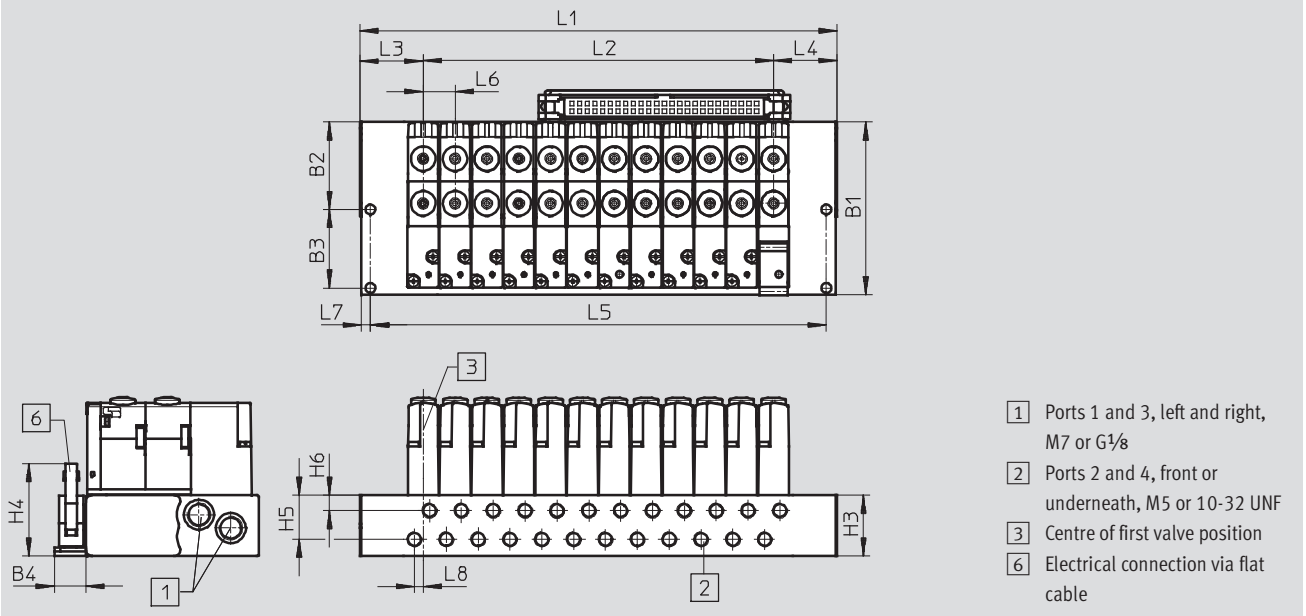

	Comment			
Pneumatic connection	–	M7	G1/8	G1/8
Through-hole	–	∅ 3.3	∅ 3.3	M4
L1	–	L2+L3+L4	L2+L3+L4	L2+L3+L4
L2	–	(n-1)x10.5	(n-1)x10.5	(n-1)x10.5
L3	Distance from centre of first valve position to outer edge on left-hand side	14.4	46.4	36.9
L4	Distance from centre of last valve position to outer edge on right-hand side	14.4	20.4	20.4
L5	–	(L1-6)	(L1-6)	(L1-6)

B1	B2	B3	B4	H3	H4	H5	H6	L6	L7	L8
	± 0.1	± 0.1							± 0.1	
57	28.9	25.9	10.4	20	30.5	14.5	5	10.5	3	2.9

Valve terminals type 84 VTOC

Technical data

FESTO

Dimensions – Flat cable underneath

Download CAD data → www.festo.com

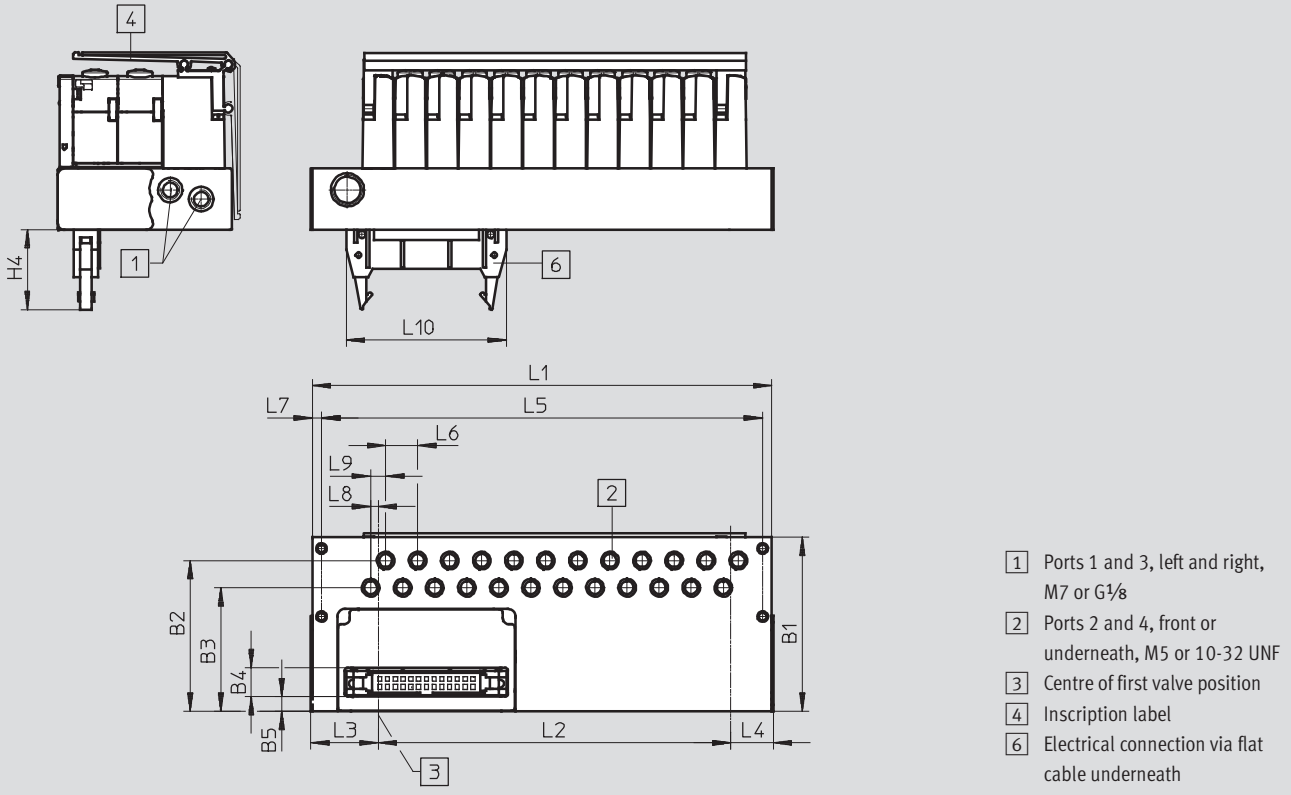

	Comment					
Pneumatic connection	-	M7 left	M7 front	G1/8 front	G1/8 left	G1/8 left
Through-hole	-	∅ 3.3	∅ 3.3	∅ 3.3	∅ 3.3	M4
L1	-	L2+L3+L4	L2+L3+L4	L2+L3+L4		
L2	-	(n-1)×10.5	(n-1)×10.5	(n-1)×10.5		
L3	Distance from centre of first valve position to outer edge on left-hand side	14.4	25.55	21.6	20.4	20.4
L4	Distance from centre of last valve position to outer edge on right-hand side	14.4	28.55	20.4	20.4	20.4
L5	-	(L1-6)	(L1-6)	(L1-6)	(L1-6)	(L1-6)

B1	B2	B3	B4	H3	H4	H5	H6	L6	L7	L8	L9	L10
	± 0.1	± 0.1							± 0.1			
57	28.9	25.9	10.4	20	30.5	14.5	5	10.5	3	2.5	4.9	52.5

Valve terminals type 84 VTOC

Technical data

FESTO

Dimensions – Pneumatic connections

Download CAD Data → www.festo.com/us/cad

Ports 2 and 4 underneath, M5 (10-32 UNF)

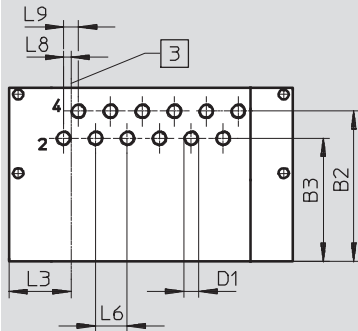

3 Centre of first valve position

Ports 2 and 4 underneath, compact

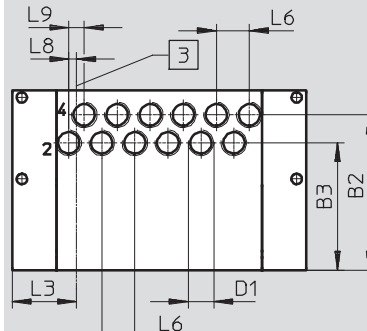

3 Centre of first valve position

Ports 2 and 4 at front, M5 (10-32 UNF)

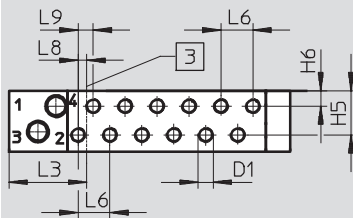

3 Centre of first valve position

Ports 2 and 4 at front, compact

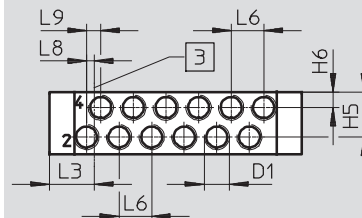

3 Centre of first valve position

Ports	B2	B3 ± 0.1	D1	H5	H6	L6	L8	L9
Underneath, M5 (10-32 UNF)	49.3	40.4	M5	–	–	10.5	2.5	4.9
Underneath, compact	49.3	40.4	M8x0.5	–	–	10.5	2.5	4.9
Front, M5 (10-32 UNF)	–	–	M5	14.5	5	10.5	2.9	5
Front, compact	–	–	M8x0.5	14.5	5	10.5	2.5	4.6

Ports 1 and 3, M7 left

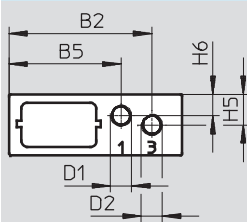

Ports 1 and 3, G1/8 left

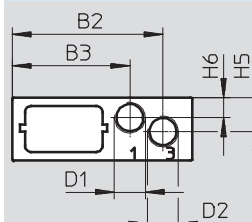

Ports 1 and 3, G1/8, left with mounting hole M4

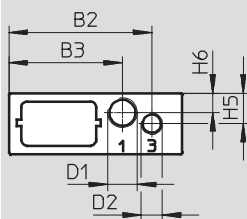

Ports 1 and 3	B2	B3	D1	D2	H5	H6
M7 left	47	36.8	M7	M7	10	7
G1/8 left	47.8	37.3	G1/8	G1/8	10.8	6.4
G1/8 left with mounting hole M4	47	37.3	G1/8	M7	10	6.4

Valve terminals type 84 VTOC

Technical data

FESTO

Dimensions – Mounting hole

Download CAD Data → www.festo.com/us/cad

∅ 3.3 underneath, ports 1 and 3, M7

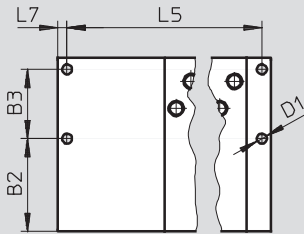

∅ 3.3 underneath, ports 1 and 3, G1/8

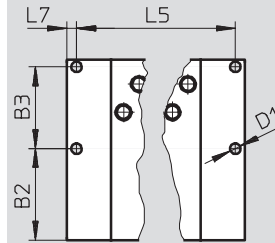

M3 underneath, ports 1 and 3, M7

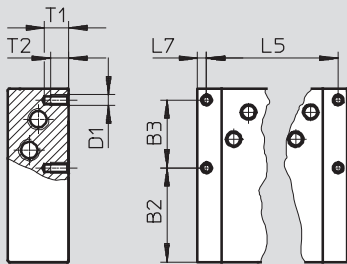

M3 underneath, ports 1 and 3, G1/8

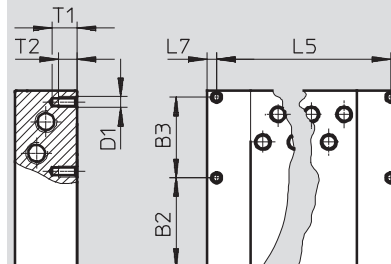

M4 underneath, ports 1 and 3, M7

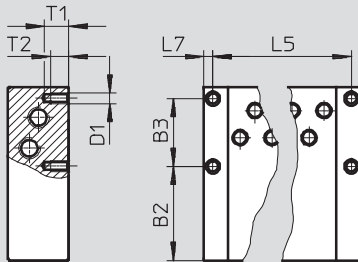

M4 or 8-32UNC underneath, ports 1 and 3, G1/8

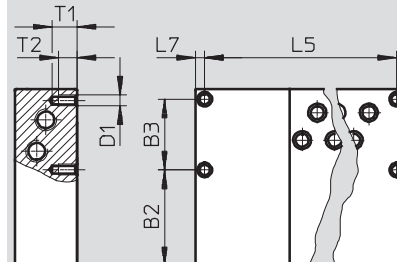

8-32UNC underneath, ports 1 and 3, M7

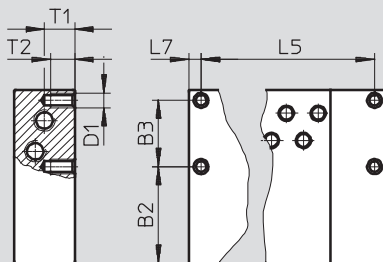

8-32UNC underneath, ports 1 and 3, G1/8

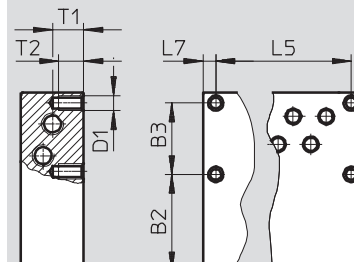

10-32UNF-2B underneath, ports 1 and 3, M7 or G1/8

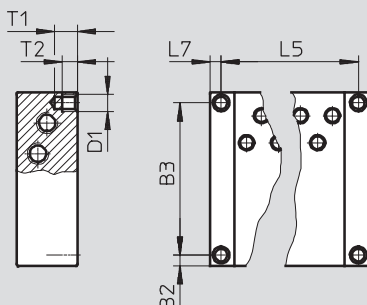



Valve terminals type 84 VTOC

Technical data

	B2	B3	D1	L5	L7	T1	T2
∅ 3.3 underneath, ports 1 and 3, M7	30.5	22.8	3.3	L1-2xL7	3	-	-
∅ 3.3 underneath, ports 1 and 3, G1/8	28.9	25.9	3.3		3	-	-
M3 underneath, ports 1 and 3, M7	31	22.3	M3		3	8	6
M3 underneath, ports 1 and 3, G1/8	28.9	25.9	M3		3	8	6
M4 underneath, ports 1 and 3, M7	31	22.3	M4		3	7.5	6
M4 or 8-32UNC underneath, ports 1 and 3, G1/8	30.8	22.8	M4 or 8-32UNC		3	7.5	6
8-32UNC underneath, ports 1 and 3, M7	31.8	21.8	8-32UNC		4	10	8
8-32UNC underneath, ports 1 and 3, G1/8	30.8	22.8	8-32UNC		4	10	8
10-32UNF-2B underneath, ports 1 and 3, M7 or G1/8	3.5	50	10-32UNF-28		3.5	7.5	5

Valve terminals type 84 VTOC

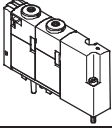
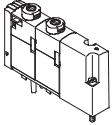
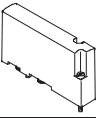

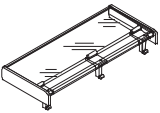
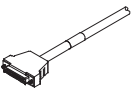

Accessories

Ordering data				
	Code	Valve function	Part No.	Type
Solenoid valves				
	K	2x3/2-way valve, single solenoid, normally closed, detenting, non-detenting/detenting manual override	565450	VOVC-BT-T32C-MT-F-1T1
	K	2x3/2-way valve, single solenoid, normally closed, non-detenting manual override	565449	VOVC-BT-T32C-MH-F-1T1
Blanking plate				
	L	Blanking plate for vacant position	565451	VABB-L2-P3
Blanking plug				
	-	For sealing the air supply or exhaust port	3568	B-1/8
			174309	B-M7
Inscription label holder				
	-	Inscription label holder for identifying the valves	3 valve positions	565571 ASCF-H-L2-3V
			4 valve positions	565572 ASCF-H-L2-4V
			5 valve positions	565573 ASCF-H-L2-5V
			6 valve positions	565574 ASCF-H-L2-6V
			7 valve positions	565575 ASCF-H-L2-7V
			8 valve positions	565576 ASCF-H-L2-8V
			9 valve positions	565577 ASCF-H-L2-9V
			10 valve positions	565578 ASCF-H-L2-10V
			11 valve positions	565579 ASCF-H-L2-11V
			12 valve positions	565580 ASCF-H-L2-12V
			13 valve positions	565581 ASCF-H-L2-13V
			14 valve positions	565582 ASCF-H-L2-14V
			15 valve positions	565583 ASCF-H-L2-15V
			16 valve positions	565584 ASCF-H-L2-16V
			17 valve positions	565585 ASCF-H-L2-17V
			18 valve positions	565586 ASCF-H-L2-18V
			19 valve positions	565587 ASCF-H-L2-19V
			20 valve positions	565588 ASCF-H-L2-20V
			21 valve positions	565589 ASCF-H-L2-21V
			22 valve positions	565590 ASCF-H-L2-22V
			23 valve positions	565591 ASCF-H-L2-23V
			24 valve positions	565592 ASCF-H-L2-24V
Connecting cable				
	-	Sub-D, 25-pin, 15-wire cable	2.5 m	530049 KMP6-25P-12-2,5
			5 m	530050 KMP6-25P-12-5
			10 m	530051 KMP6-25P-12-10
		Sub-D, 25-pin, 25-wire cable	2.5 m	530046 KMP6-25P-20-2,5
			5 m	530047 KMP6-25P-20-5
			10 m	530048 KMP6-25P-20-10

Valve terminals type 84 VTOC

Accessories

FESTO

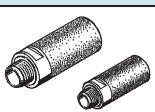
Ordering data						
	Code	Description	Tubing O.D.	Packaging unit	Part No.	Type
Push-in fittings						Technical data → Internet: quick star
	-	QS push-in fitting	1/4"	1 piece	183741	QS-1/8-1/4-I-U-M
			3/8"	1 piece	567773	QS-1/8-3/8-U
			8 mm	10 pieces	153015	QS-1/8-8-I
			6 mm	10 pieces	153321	QSM-M7-6-I
			1/4"	1 piece	183740	QSM-M7-1/4-I-U-M
			1/8"	10 pieces	183749	QSM-M5-1/8-I-U-M
			5/32"	10 pieces	130593	QSM-M5-5/32-I-U-M
			3 mm	10 pieces	153313	QSM-M5-3-I
	-	Push-in L-fitting	8 mm	20 pieces	130928	QSL-B-1/8-8-20
			3/16	1 piece	533234	QBL-1/8-3/16-U-M
			1/4	1 piece	533235	QBL-1/8-1/4-U-M
			3/8	1 piece	562578	QBL-1/8-3/8-U-M
			3 mm	10 pieces	130830	QSMLV-M5-3-I
			4 mm	10 pieces	130831	QSMLV-M5-4-I
	-	Push-in L-fitting, long	3 mm	10 pieces	130834	QSMLLV-M5-3-I
			4 mm	10 pieces	130835	QSMLLV-M5-4-I
	-	T-fitting	1/4	1 piece	533254	QST-H-1/8-1/4-U-M
			3/8	1 piece	562579	QST-H-1/8-3/8-U-M
			8 mm	20 pieces	130940	QST-B-1/8-8-20
Silencer						Technical data → Internet: quick star
	U	Silencer	-	1 piece	161418	UC-M7
				50 pieces	534218	UC-M7-50

Product Range and Company Overview

A Complete Suite of Automation Services

Our experienced engineers provide complete support at every stage of your development process, including: conceptualization, analysis, engineering, design, assembly, documentation, validation, and production.



Custom Automation Components
Complete custom engineered solutions



Custom Control Cabinets
Comprehensive engineering support and on-site services



Complete Systems
Shipment, stocking and storage services

The Broadest Range of Automation Components

With a comprehensive line of more than 30,000 automation components, Festo is capable of solving the most complex automation requirements.



Electromechanical
Electromechanical actuators, motors, controllers & drives



Pneumatics
Pneumatic linear and rotary actuators, valves, and air supply



PLCs and I/O Devices
PLC's, operator interfaces, sensors and I/O devices

Supporting Advanced Automation... As No One Else Can!

Festo is a leading global manufacturer of pneumatic and electromechanical systems, components and controls for industrial automation, with more than 12,000 employees in 56 national headquarters serving more than 180 countries. For more than 80 years, Festo has continuously elevated the state of manufacturing with innovations and optimized motion control solutions that deliver higher performing, more profitable automated manufacturing and processing equipment. Our dedication to the advancement of automation extends beyond technology to the education and development of current and future automation and robotics designers with simulation tools, teaching programs, and on-site services.

Quality Assurance, ISO 9001 and ISO 14001 Certifications

Festo Corporation is committed to supply all Festo products and services that will meet or exceed our customers' requirements in product quality, delivery, customer service and satisfaction.

To meet this commitment, we strive to ensure a consistent, integrated, and systematic approach to management that will meet or exceed the requirements of the ISO 9001 standard for Quality Management and the ISO 14001 standard for Environmental Management.



© Copyright 2008, Festo Corporation. While every effort is made to ensure that all dimensions and specifications are correct, Festo cannot guarantee that publications are completely free of any error, in particular typing or printing errors. Accordingly, Festo cannot be held responsible for the same. For Liability and Warranty conditions, refer to our "Terms and Conditions of Sale", available from your local Festo office. All rights reserved. No part of this publication may be reproduced, distributed, or transmitted in any form or by any means, electronic, mechanical, photocopying or otherwise, without the prior written permission of Festo. All technical data subject to change according to technical update.



Printed on recycled paper at New Horizon Graphic, Inc., FSC certified as an environmentally friendly printing plant.

Festo North America

Festo Regional Contact Center

5300 Explorer Drive
Mississauga, Ontario L4W 5G4
Canada

USA Customers:

For ordering assistance,

Call: 1.800.99.FESTO (1.800.993.3786)

Fax: 1.800.96.FESTO (1.800.963.3786)

Email: customer.service@us.festo.com

For technical support,

Call: 1.866.GO.FESTO (1.866.463.3786)

Fax: 1.800.96.FESTO (1.800.963.3786)

Email: product.support@us.festo.com

Canadian Customers:

Call: 1.877.GO.FESTO (1.877.463.3786)

Fax: 1.877.FX.FESTO (1.877.393.3786)

Email: festo.canada@ca.festo.com

USA Headquarters

Festo Corporation
395 Moreland Road
P.O. Box 18023
Hauppauge, NY 11788, USA
www.festo.com/us

USA Sales Offices

Appleton

North 922 Tower View Drive, Suite N
Greenville, WI 54942, USA

Boston

120 Presidential Way, Suite 330
Woburn, MA 01801, USA

Chicago

1441 East Business Center Drive
Mt. Prospect, IL 60056, USA

Dallas

1825 Lakeway Drive, Suite 600
Lewisville, TX 75057, USA

Detroit – Automotive Engineering Center

2601 Cambridge Court, Suite 320
Auburn Hills, MI 48326, USA

New York

395 Moreland Road
Hauppauge, NY 11788, USA

Silicon Valley

4935 Southfront Road, Suite F
Livermore, CA 94550, USA

United States



USA Headquarters, East: Festo Corp., 395 Moreland Road, Hauppauge, NY 11788

Phone: 1.631.435.0800; Fax: 1.631.435.8026;

Email: info@festo-usa.com

www.festo.com/us

Canada



Headquarters: Festo Inc., 5300 Explorer Drive, Mississauga, Ontario L4W 5G4

Phone: 1.905.624.9000; Fax: 1.905.624.9001;

Email: festo.canada@ca.festo.com

www.festo.ca

Mexico



Headquarters: Festo Pneumatic, S.A., Av. Ceylán 3, Col. Tequesquahuac,
54020 Tlalneantla, Edo. de México

Phone: 011 52 [55] 53 21 66 00; Fax: 011 52 [55] 53 21 66 65;

Email: festo.mexico@mx.festo.com

www.festo.com/mx

Central USA

Festo Corporation
1441 East Business
Center Drive
Mt. Prospect, IL 60056, USA
Phone: 1.847.759.2600
Fax: 1.847.768.9480



Western USA

Festo Corporation
4935 Southfront Road,
Suite F
Livermore, CA 94550, USA
Phone: 1.925.371.1099
Fax: 1.925.245.1286



Festo Worldwide

Argentina Australia Austria Belarus Belgium Brazil Bulgaria Canada Chile China Colombia Croatia Czech Republic Denmark
Estonia Finland France Germany Great Britain Greece Hong Kong Hungary India Indonesia Iran Ireland Israel Italy Japan Latvia
Lithuania Malaysia Mexico Netherlands New Zealand Norway Peru Philippines Poland Romania Russia Serbia Singapore
Slovakia Slovenia South Africa South Korea Spain Sweden Switzerland Taiwan Thailand Turkey Ukraine United States Venezuela

www.festo.com