

Linear modules HMPL

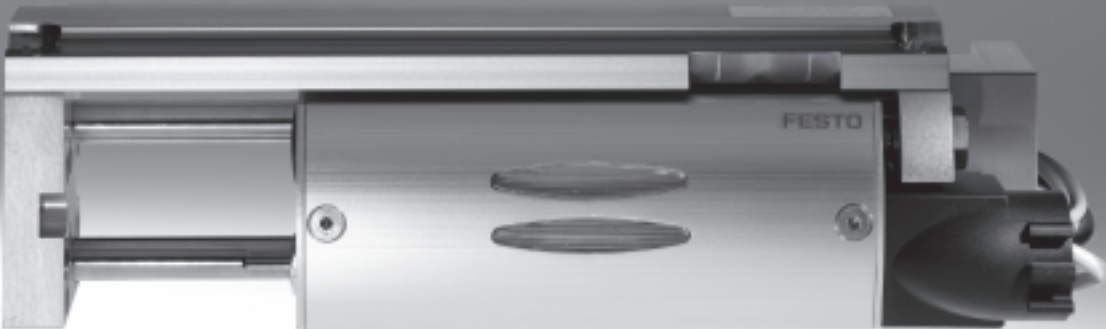

Linear modules HMPL

Key features

FESTO

At a glance

- Diameter of 12 ... 20 mm
- Stroke lengths of 30 ... 200 mm
- The drive design ensures maximum force and dynamics, especially for vertical operation.
- High precision:
 - Four press-fitted recirculating ball bearing guides and two guide rods ensure high precision and good rigidity
 - Metallic inserts in the limit stops ensure exceptional end-position accuracy results
- Highly dynamic:
 - With integrated shock absorbers, exhaust air flow control and a very rigid housing, the linear module HMPL is capable of cycle times down to <0.5 seconds.
- User-friendly installation system:
 - Centrally arranged and protected cables and tubing.
- Lightweight:
 - The linear module HMPL has a very low dead weight, making it ideal as a front-end axis for the Festo modular system for handling and assembly.
- Modular functionality:
 - By means of versatile and accurate mounting options.

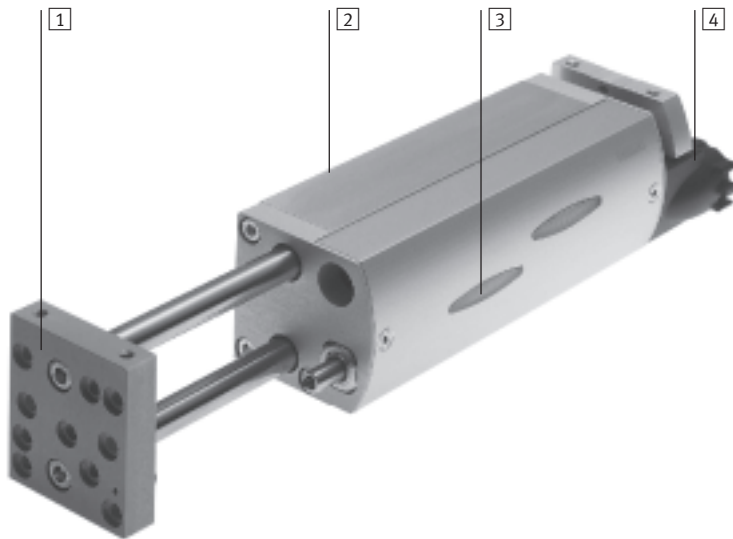

- 1** Front plate
With precision mounting options for attachment components such as drives, grippers, etc.
- 2** Basic profile
The rigid, sealed housing contains both guide and cylinder. High precision and load capacity is achieved by means of the large spacing between the recirculating ball bearing guides.
- 3** Housing cover
For protection against contamination of internal components and with built-in display window.
- 4** Connector cap
Cables and tubing are arranged externally in a centralised, safe and convenient fashion. With mounting option for sensor inscription labels.

Linear modules HMPL

Key features

Wide choice of variants

Internal stop element and position sensing

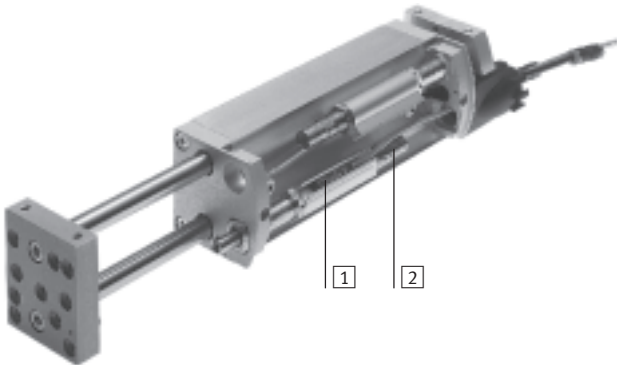

1 Internal stop element
Self-adjusting soft shock absorbers with metallic inserts are used in both end positions. The stop element combines important handling technology functions including position sensing, cushioning stroke adjustment and drive stroke adjustment. Depending upon the size of the stop elements, the end positions can be precision adjusted within a range of up to 20 mm.

2 Position sensing
Sensor slots for proximity sensor SME/SMT-8 are included in the stop elements. The proximity sensor's LED position display can be viewed at the two display windows in the housing cover, even when the linear module is closed.

Clamping unit



A clamping cartridge holds the clamping rod by means of friction (for safety in the event of pressure failure). The clamping rod is attached to the front plate. When the clamping cartridge is pressurised, the guide

rods move freely along with the front plate and the yoke plate. The clamping cartridge can be released by means of an integrated manual override.

Active intermediate position



Travel to any desired position between the end positions of the linear module is made possible with an additionally attached cylinder, and an additional stop element. The intermediate position can be approached from

either the rear or the front end position. Furthermore, continued travel in the original direction is also possible from the intermediate position.

Reinforcing plate



For additional stability, especially for multi-axis operation. The reinforcing plate is attached via the front plate and the yoke plate. Additional functions include a dovetail for

flexible adaptation, and three through-holes through which tubing or cables can be fed, or which can be used for direct air connection.

Linear modules HMPL

System example

System elements and accessories		
	Brief description	→ Page/Internet
1	Drives	Wide range of combination options within handling and assembly technology drive
2	Grippers	Wide range of combination options within handling and assembly technology gripper
3	Basic components	Profiles and profile combinations as well as profile/drive combinations basic component
4	Installation components	For achieving a clear-cut, safe layout for electrical cables and tubing installtion component
-	Adapters	For combining drives with drives and drives with grippers adapter kit
-	Axes	Wide range of combination options within handling and assembly technology axes
-	Motors	Servo and stepper motors, with or without gearing motor

Linear modules HMPL

Peripherals overview

FESTO

Peripherals overview

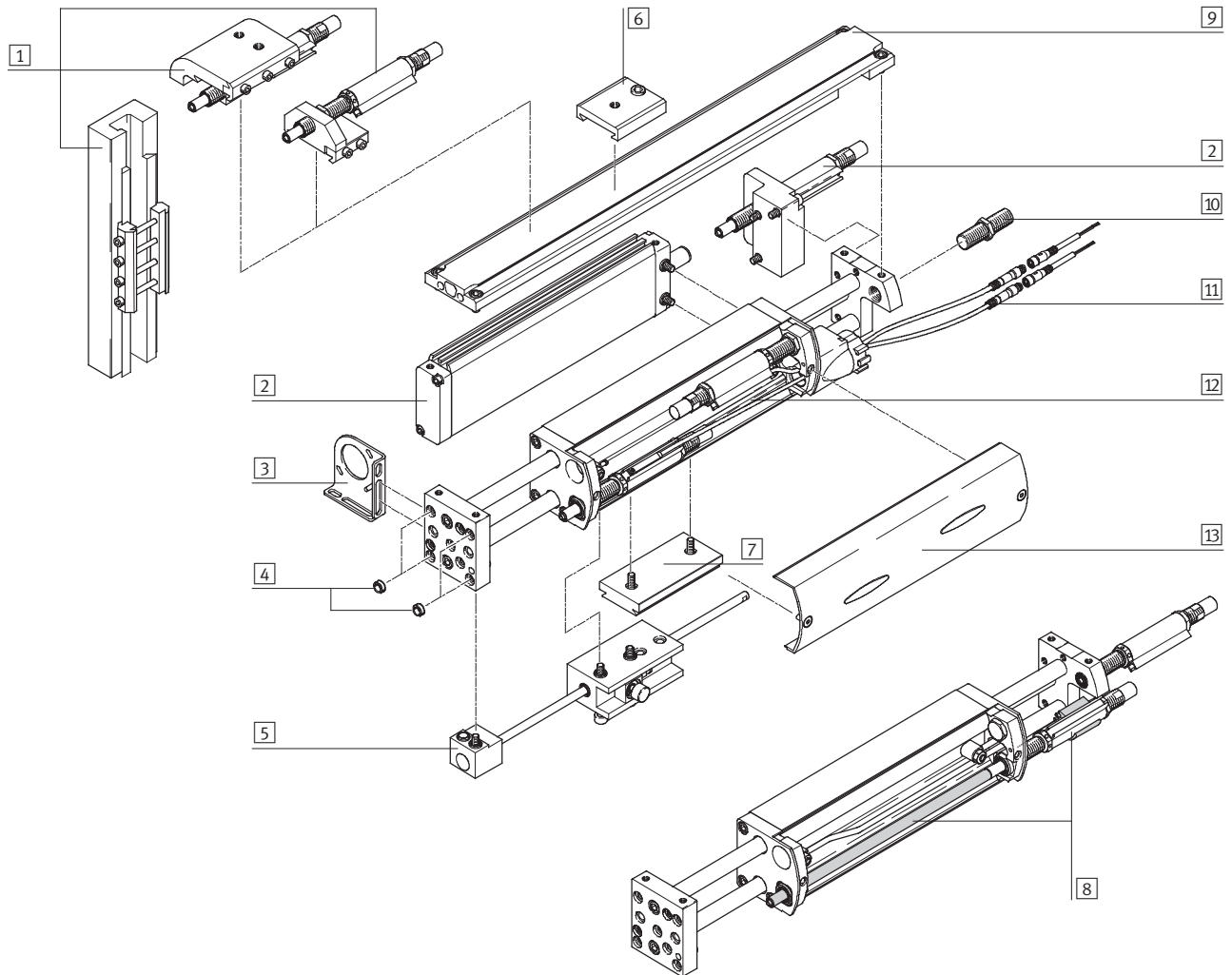

Linear modules HMPL

Peripherals overview

Accessories		
	Brief description	→ Page/Internet
1	Passive intermediate position	25
2	Active intermediate position M	26
3	Mounting bracket H	1 / 7.1-30
4	Centring sleeve Z	35
5	Clamping unit KP	22
6	Clamping component J	1 / 7.1-30
7	Adapter I	1 / 7.1-30
8	Stop element AI/AE	20
9	Reinforcing plate VP	24
10	Stop bolt K	1 / 7.1-30
11	Cable with socket V	36
12	Proximity sensor 2A...	35
13	Housing cover	–

Linear modules HMPL

Type codes

		HMPL	-	20	-	200	-	AI	-		-	KP	-	100 M	-	2A1
Type																
HMPL	Linear module															
Piston Ø [mm]																
Stroke [mm]																
Stop element																
AI	Integrated															
AE	External															
Reinforcement																
VP	Reinforcing plate															
Clamping unit																
KP	Supplied separately															
Active intermediate position																
...M	Active intermediate position															
Proximity sensor																
2A1	With cable, 2.5 m															
2A2	Contactless with cable, 2.5 m, NPN															
2A3	Contactless with cable, 2.5 m, PNP															
2A4	With plug															
2A5	Contactless with plug, NPN															
2A6	Contactless with plug, PNP															

Linear modules HMPL

Type codes

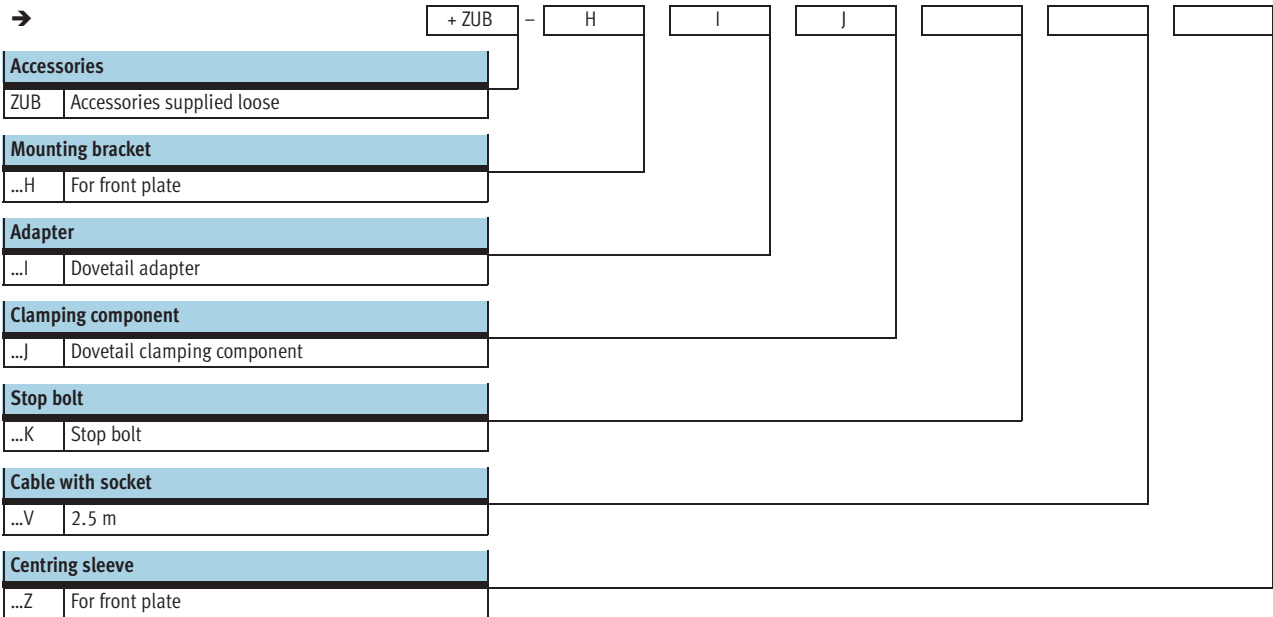

Linear modules HMPL

Technical data

FESTO

Function



-  - Piston \varnothing
12 ... 20 mm

-  - Stroke length
30 ... 200 mm

-  - [www.festo.com/en/
Spare_parts_service](http://www.festo.com/en/Spare_parts_service)

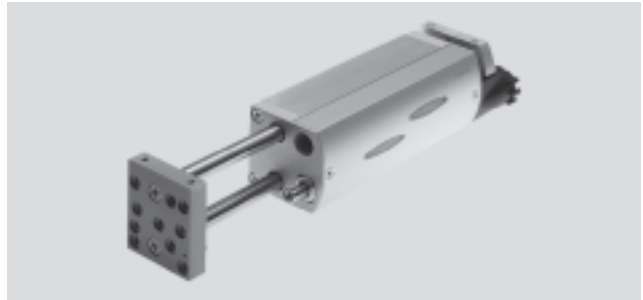

General technical data				
Piston \varnothing		12	16	20
System mode	Yoke			
Mode of operation	Double-acting			
Constructional design	Piston			
	Piston rod			
	Guide rod			
	Front and yoke plate			
Type of connection	Female thread			
	For 2 already integrated one-way flow control valves with 2 tubes with O.D. 4 mm and 2 push-in fittings QSM-4			
Pneumatic connection	M5			
Mounting position	Any			
Stroke	[mm]	30 ... 100	50 ... 160	50 ... 200
Stroke adjustment per end position	[mm]	15	20	
Position sensing	For proximity sensing			
Max. repetition accuracy ¹⁾	[mm]	0.02		

1) Variation of end position for 100 successive strokes under constant operating conditions

Operating and environmental conditions				
Piston \varnothing		12	16	20
Operating pressure	[bar]	4 ... 8		
Operating medium	Filtered compressed air, lubricated or unlubricated			
Ambient temperature ¹⁾	[°C]	0 ... +60		
Noise level L_{pEq}	[dB(A)]	62	57	56

1) Note operating range of proximity sensors

Forces [N]				
Piston \varnothing		12	16	20
Theoretical force at 6 bar, advancing		51	104	158
Theoretical force at 6 bar, retracting		68	121	188

Linear modules HMPL

Technical data

Weights [g]				
Piston Ø		12	16	20
Product weight with stroke (HMPL-...-Al)	30 mm	610	–	–
	50 mm	658	975	1 439
	80 mm	770	1 090	1 591
	100 mm	843	1 194	1 739
	125 mm	–	1 318	1 888
	160 mm	–	1499	2 179
	200 mm	–	–	2 471
Moving load with stroke (HMPL-...-Al)	30 mm	244	–	–
	50 mm	272	401	584
	80 mm	326	467	679
	100 mm	362	521	758
	125 mm	–	587	856
	160 mm	–	681	993
	200 mm	–	–	1 150

Materials

Sectional view

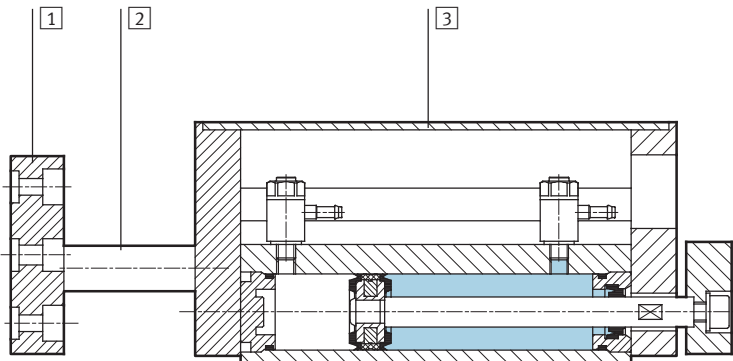

Linear module		
1	Front plate	Anodised aluminium
2	Guide rods	Tempered steel
3	End cap	Anodised aluminium
–	Reinforcing plate	Anodised aluminium
–	Seals	Nitrile rubber, polyurethane
	Material note	Free of copper, PTFE and silicone

Linear modules HMPL

Technical data

Permissible torque M as a function of the stroke length l (at the front plate)

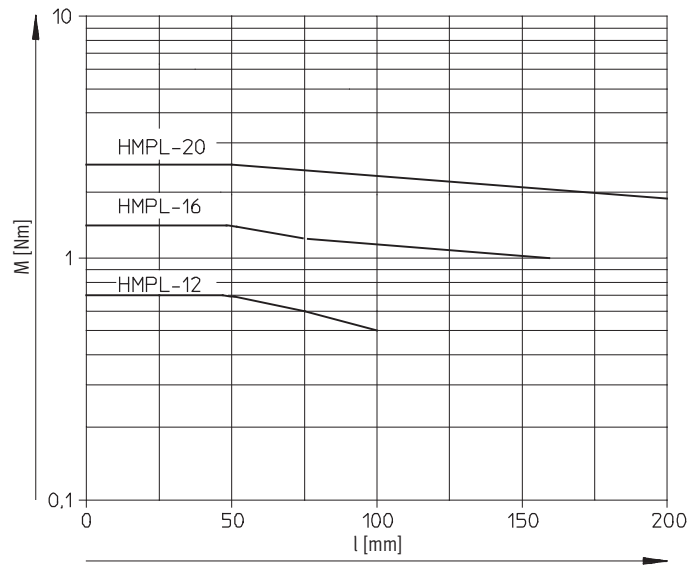
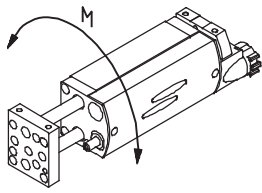

Permissible effective load Fq as a function of the stroke length l (at the front plate)

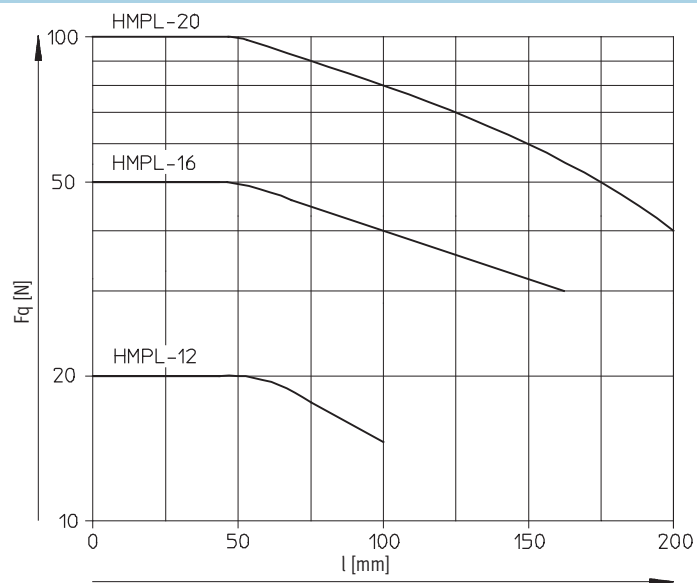
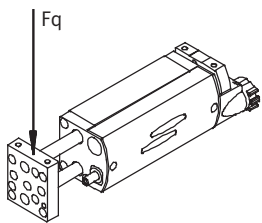

Linear modules HMPL

Technical data

Deflection/deformation f as a function of the applied load m and the position l (stroke)

Primary direction with reinforcing plate

Primary direction without reinforcing plate

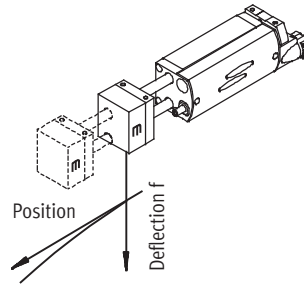
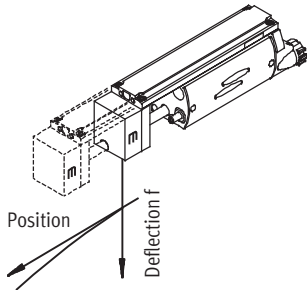

HMPL-12

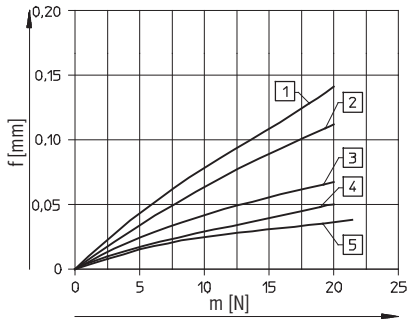

HMPL-12

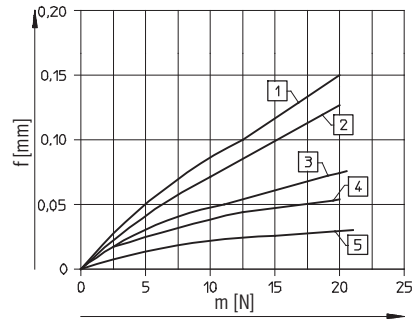

HMPL-16

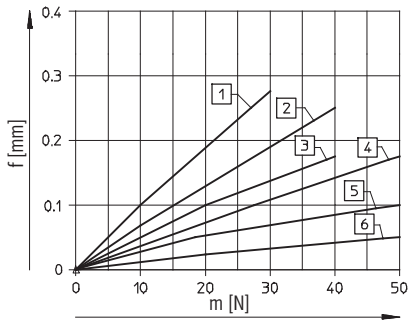

HMPL-16

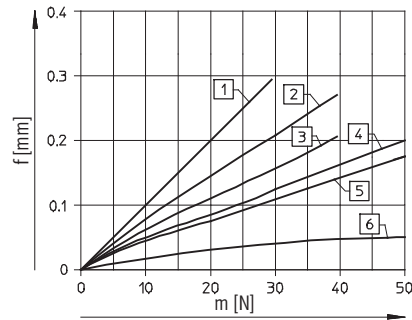

HMPL-20

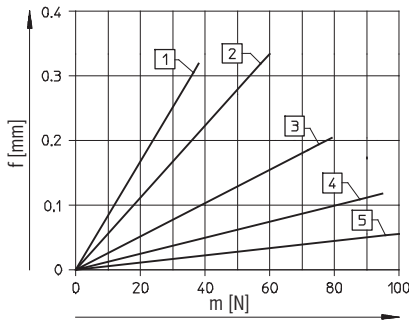

HMPL-20

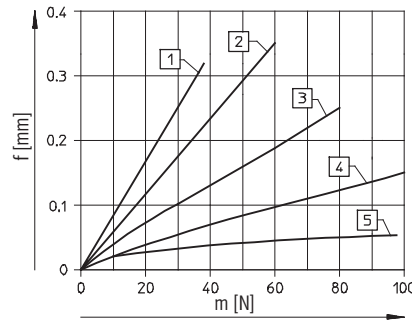

Linear modules HMPL

Technical data

FESTO

Permissible horizontal travel time t at 6 bar as a function of the stroke length and the applied load m

Advancing

Retracting

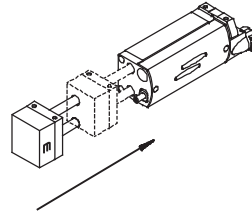
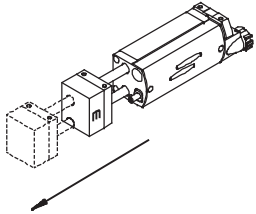

HMPL-12

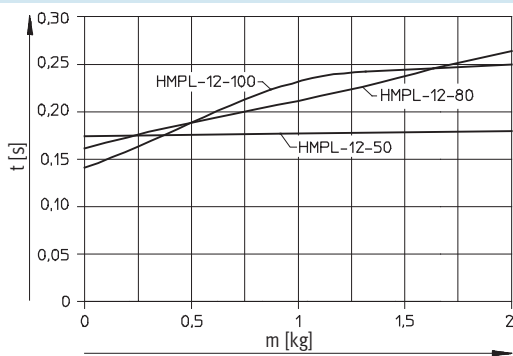

HMPL-12

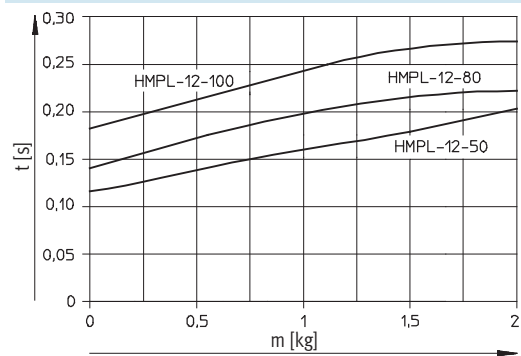

HMPL-16

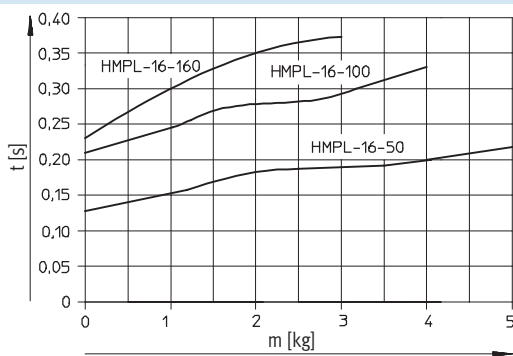

HMPL-16

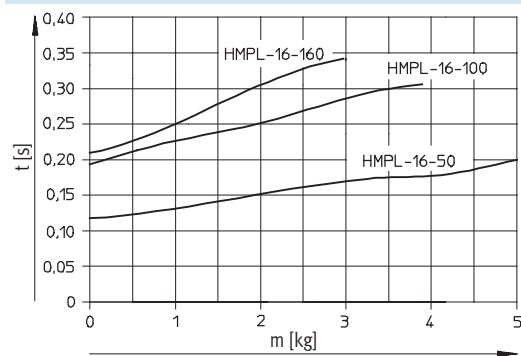

HMPL-20

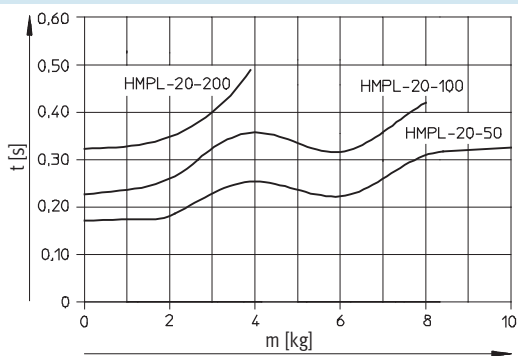

HMPL-20

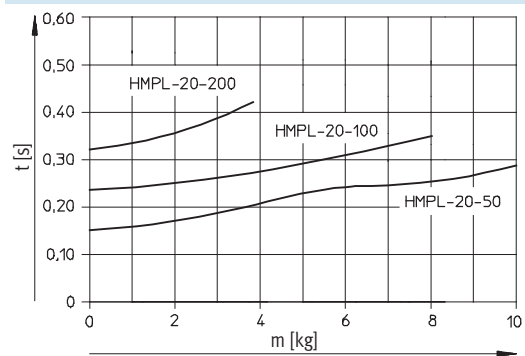

Linear modules HMPL

Technical data

Permissible vertical travel time t at 6 bar as a function of the stroke length and the applied load m

Advancing

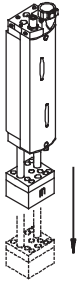

Retracting

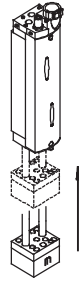

HMPL-12

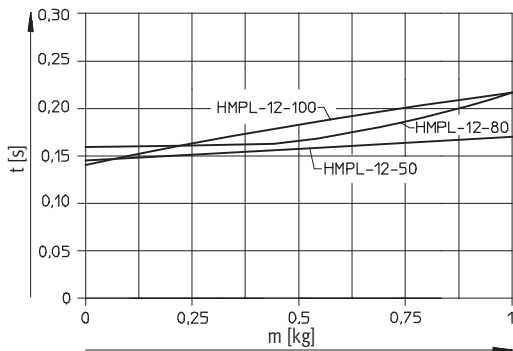

HMPL-12

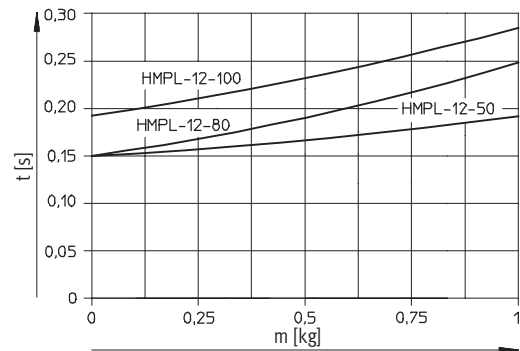

HMPL-16

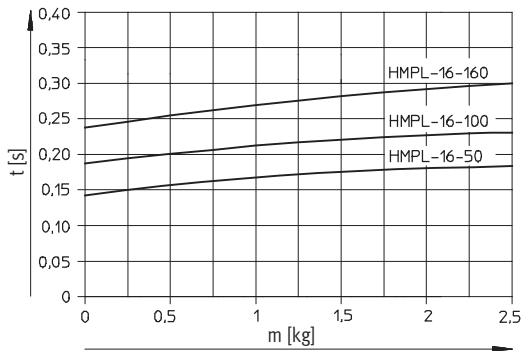

HMPL-16

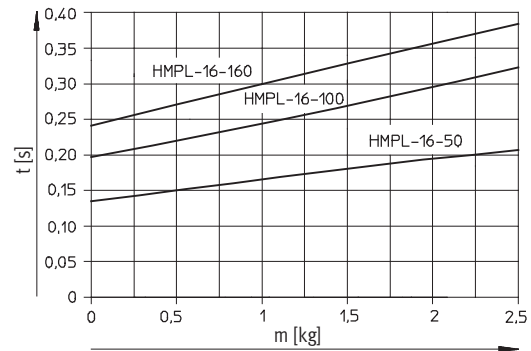

HMPL-20

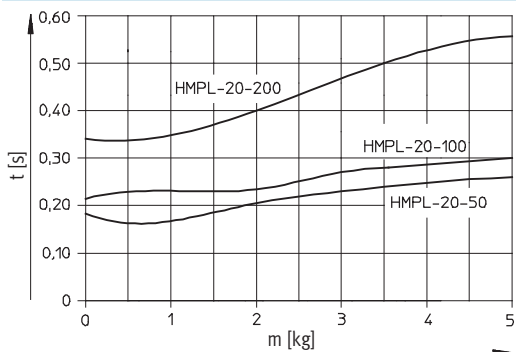

HMPL-20

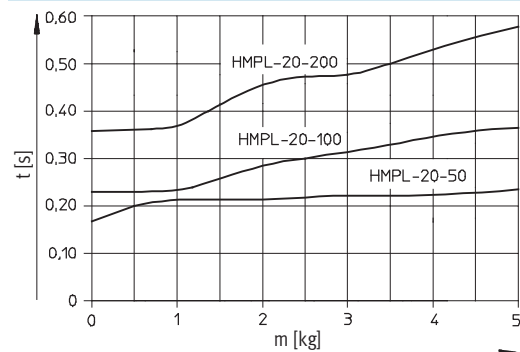

Linear modules HMPL

Technical data

FESTO

Dimensions

Download CAD Data → www.festo.com/us/cad

Piston \varnothing 20 mm

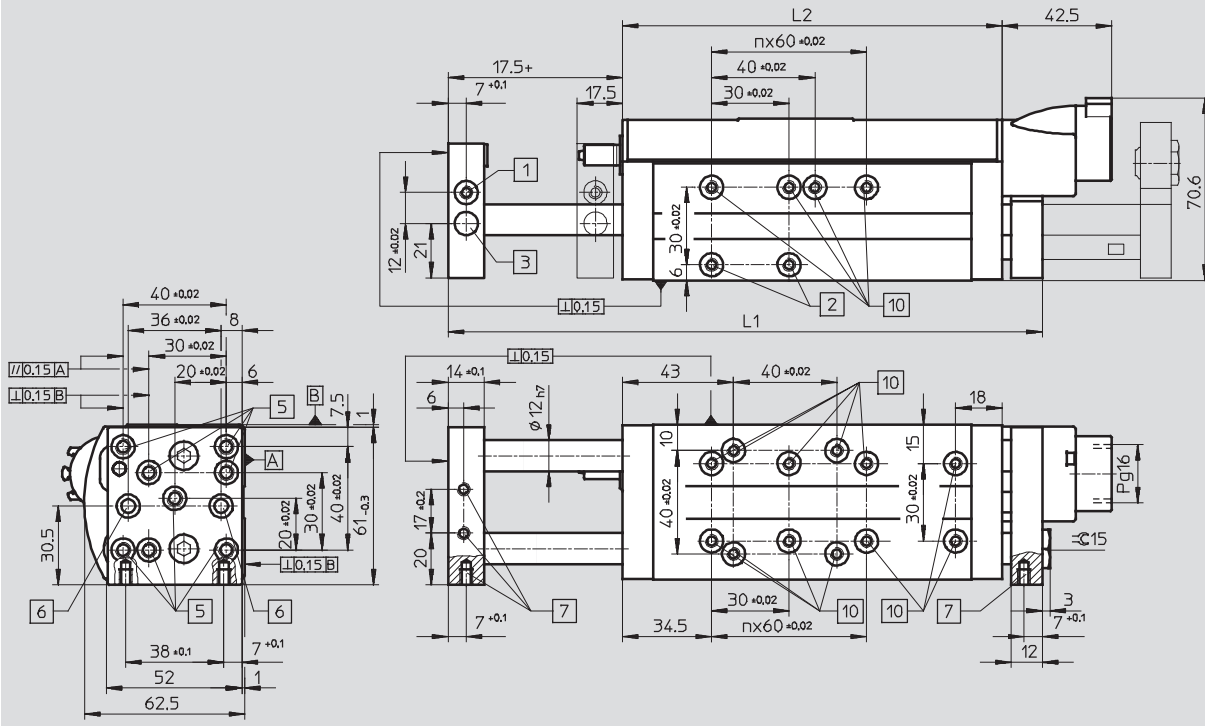

A, B = Mounting surfaces + = plus stroke length

Hole patterns on the housing and the front plate

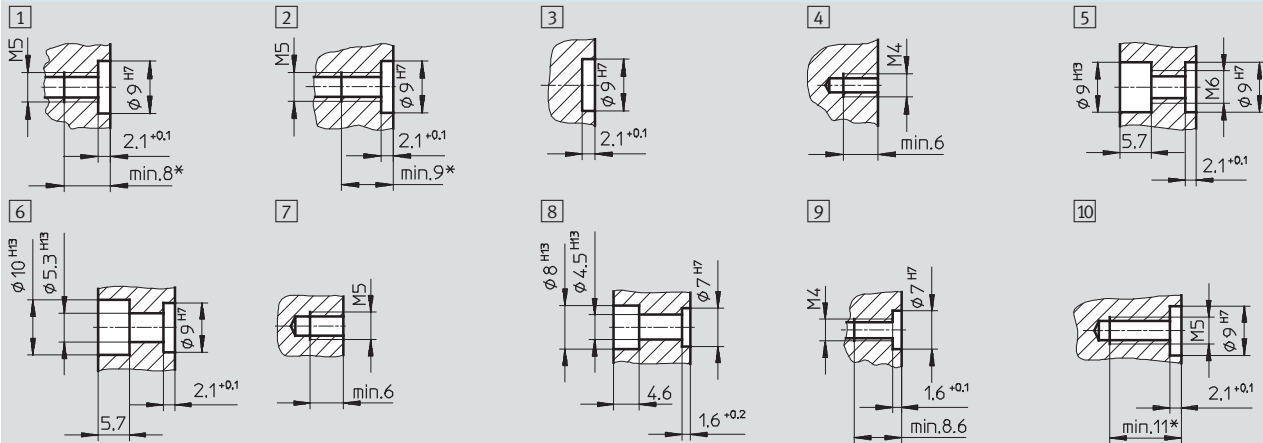

* Max. screw-in depth

\varnothing [mm]	Stroke [mm]	L1 +0.25/-0.1	L2 +0.2/-0.4	n
12	-	172	111	1
	50	202	121	
	80	262	151	
	100	302	171	2
	-	-	-	
	-	-	-	

\varnothing [mm]	Stroke [mm]	L1 +0.25/-0.1	L2 +0.2/-0.4	n
16	-	-	-	-
	50	217	134	1
	80	267	154	
	100	307	174	
	125	357	199	2
	160	427	234	
	-	-	-	

\varnothing [mm]	Stroke [mm]	L1 +0.25/-0.1	L2 +0.2/-0.4	n
20	-	-	-	-
	50	230	147	1
	80	267	154	
	100	307	174	
	125	357	199	2
	160	427	234	
	200	507	274	

Linear modules HMPL

Technical data

FESTO

Mounting options – Variant A

(Y/Z axes in primary direction)

Piston Ø 20 mm

Piston Ø 16 mm

Piston Ø 12 mm

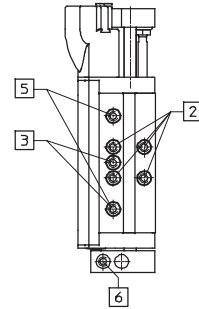
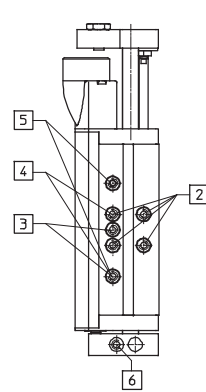
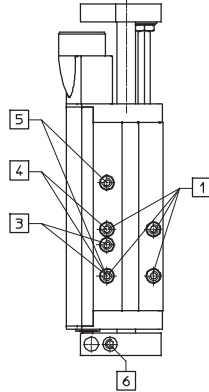
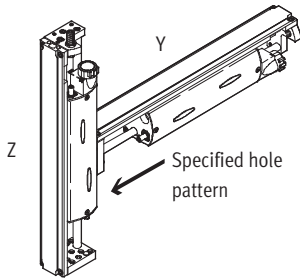

	Y axis	Z axis	Grid dimension [mm]	Mounting thread	Centring sleeve
1	HMPL-20	HMPL-20	30x30	M5	ZBH-9
2	HMPL-16	HMPL-12/-16	20x20	M5	ZBH-9
	HMPL-12	HMPL-12			
	Clamping unit HMPL-12-...-KP		20	M5	ZBH-9
3	Clamping unit HMPL-16/-20-...-KP		30	M5	ZBH-9
4	Mounting bracket HMBV		40	M5	ZBH-9
5	HMP-16/-20/-25	–	60	M5	ZBH-9
	Dovetail adapter				
	Clamping unit HMPL-...-KP for attachment to HMP front plate				
6	Clamping unit mounting		–	M5	2x ZBH-9

Mounting options – Variant B

(Y axis in primary direction)

Piston Ø 20 mm

Piston Ø 16 mm

Piston Ø 12 mm

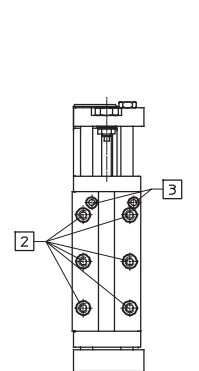
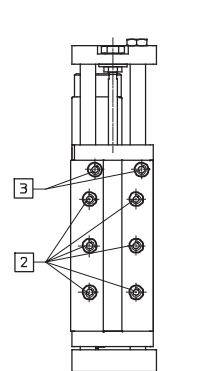
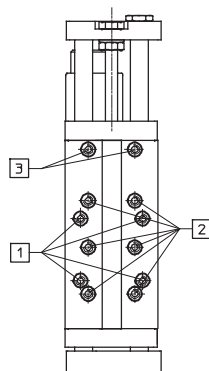
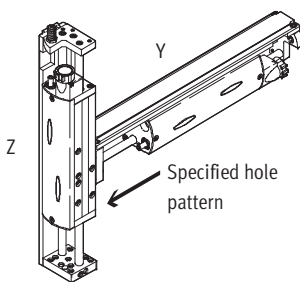

	Y axis	Z axis	Grid dimension [mm]	Mounting thread	Centring sleeve
1	HMPL-20	HMPL-20	40x40	M5	ZBH-9
	Mounting bracket HMBV				
2	HMPL-20	HMPL-12/-16/-20	30x30	M5	ZBH-9
	HMPL-16	HMPL-12/-16			
3	Active intermediate position HMPL-16/-20		–	2x M5	ZBH-9
	Active intermediate position HMPL-12			2x M4	ZBH-7

Linear modules HMPL

Technical data

FESTO

Mounting options – Front plate

(Y/Z axes in primary direction)

Piston Ø 20 mm

Piston Ø 16 mm

Piston Ø 12 mm

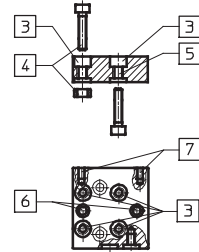
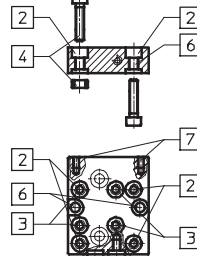
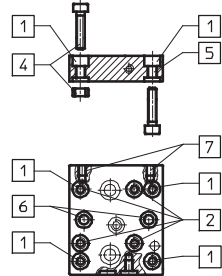

- 1) Mounting option variants
- 2) Through-holes for socket head screws

	Y axis	Z axis	Grid dimension [mm]	Mounting thread	Centring sleeve
1	HMPL-20	HMPL-20 B ¹⁾	40x40	M6	ZBH-9
2	HMPL-20	HMPL-20 A ¹⁾	30x30	M6	ZBH-9
	HMPL-16	HMPL-12/-16 B ¹⁾			
	Adapter kits HAPG-36/-37/-38 for grippers				
	Swivel/gripper unit HGDS-16/-20				
3	HMPL-16	HMPL-12/-16 B ¹⁾	20x20	M6	ZBH-9
	HMPL-12	HMPL-12 A ¹⁾			
	HMPL-12: Adapter kits HAPG-39/-60 for grippers				
	Adjustment unit HMX-1				
	Swivel/gripper unit HGDS-12				
4	Attachment of all Z axes HMPL		-	M5 ²⁾	ZBH-9
5	Individual mounting		-	M6	-
6	HMPL-12: Direct mounting DRQD-6		-	M4 ²⁾	ZBH-7
	HMPL-16/-20: Direct mounting DRQD-8/-12		-	M5 ²⁾	ZBH-9
7	HMPL-12/16: Reinforcing plate		-	2x M4	-
	HMPL-20: Reinforcing plate		-	2x M5	-

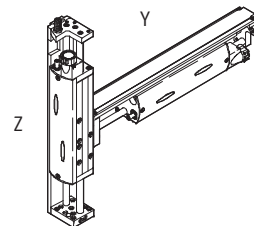
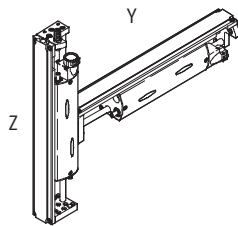

- 1) Screws and centring sleeves are not included with the drives.

HMPL/HMPL and HMP/HMPL combinations

	Y/Z axes in primary direction ¹⁾			Y axis in primary direction ¹⁾		
	HMPL-12	HMPL-16	HMPL-20	HMPL-12	HMPL-16	HMPL-20
HMPL-12	2x M5x16 2x ZBH-9	-	-	-	-	-
HMPL-16	2x M5x16 2x ZBH-9	2x M5x16 2x ZBH-9	-	2x M5x16 2x ZBH-9	2x M5x16 2x ZBH-9	-
HMPL-20	2x M5x16 2x ZBH-9	2x M5x16 2x ZBH-9	2x M5x16 2x ZBH-9	2x M5x16 2x ZBH-9	2x M5x16 2x ZBH-9	2x M5x16 2x ZBH-9
HMP-16	2x M5x22 2x ZBH-9	2x M5x22 2x ZBH-9	2x M5x22 2x ZBH-9	-	-	-
HMP-20	2x M5x22 2x ZBH-9	2x M5x22 2x ZBH-9	2x M5x22 2x ZBH-9	-	-	-
HMP-25	-	2x M5x30 2x ZBH-9	2x M5x30 2x ZBH-9	-	-	-

Linear modules HMPL

Technical data



Stop element YSRWJ

for position sensing, cushioning stroke adjustment and drive stroke adjustment.



Retrofit kit for external stop element

BAE-HMPL-...

The integrated (code AI) or external (code AE) stop element can be ordered via the modular product system. The kit BAE-HMPL and additionally the stop element YSRWJ can be ordered for external retrofitting.



- 1 Soft cushioning characteristics. The cushioning stroke is adjustable
- 2 Precision end position thanks to internal, metallic inserts
- 3 Precision end-position adjustment
- 4 Position sensing via integratable proximity sensor SME-8/SMT-8

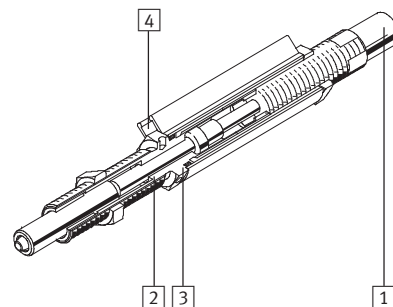

General technical data			
	YSRWJ-5-8-A	YSRWJ-7-10-A	YSRWJ-8-14-A
Piston Ø	5	7	8
Stroke [mm]	8	10	14
Max. energy per stroke [Nm]	1	2	3
absorption per hour [Nm]	10000	15000	21000
Load range [kg]	2	5	10
Reset time ¹⁾ [s]	< 0.2		
Max. residual impact force ²⁾ [N]	200	300	500

1) Increased rest times must be expected at low temperatures (0 °C).
 2) Impact force may not exceed the maximum specified value.

Operating and environmental conditions			
Piston Ø	5	7	8
Ambient temperature [°C]	0 ... +60		

Weights [g]			
Piston Ø	5	7	8
	45	75	110

Linear modules HMPL

Technical data

Dimensions – External stop element

Download CAD Data → www.festo.com/us/cad

HMPL-...-AE (code AE)

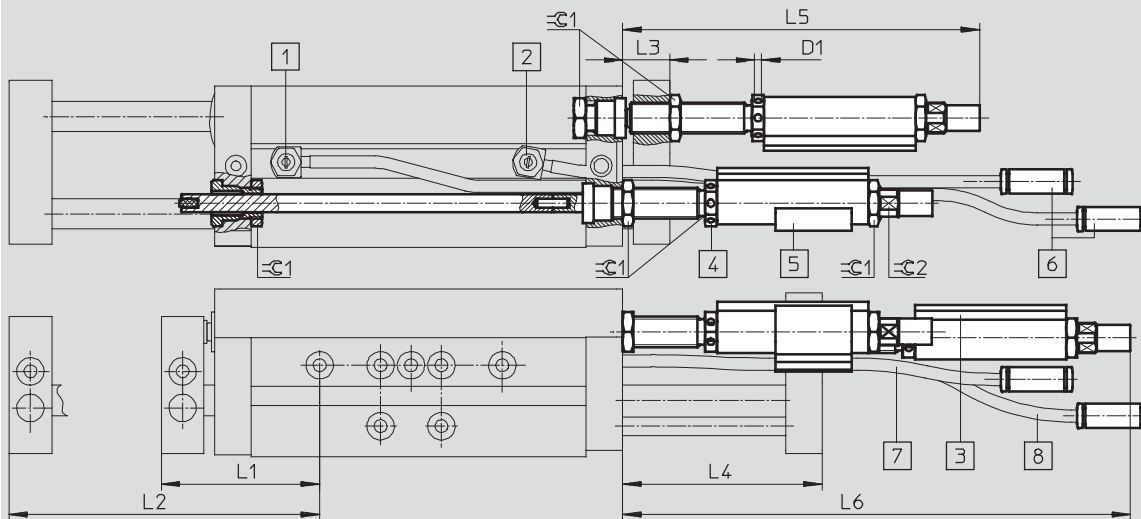

- 1 Speed adjustment via one-way flow control valve, advancing
- 2 Speed adjustment via one-way flow control valve, retracting
- 3 Slot for proximity sensor SME-8/SMT-8 and identification labels
- 4 Drilled hole for precision stroke adjustment with internal hex
- 5 Tubing clip for attaching cables, proximity sensors and tubing
- 6 Push-in fitting QSM-4
- 7 Tubing, silver = return stroke air connection
- 8 Tubing, black = forward stroke air connection

∅	Stroke	D1 ∅	L1	L2	L3	L4	L5	L6	∅ 1	∅ 2
[mm]	[mm]	+0.1	+15 ¹ /-0.5	+0.5/-15 ²	+15 ¹ /-0.5	+0.5/-15 ²	+2	+2/-15 ²		
12	30	2	42.3	72.3	13.7	43.7	98.9	131.1	10	7
	50			92.3		63.7		151.1		
	80			122.3		93.7		181.1		
	100			142.3		113.7		201.1		

∅	Stroke	D1 ∅	L1	L2	L3	L4	L5	L6	∅ 1	∅ 2
[mm]	[mm]	+0.1	+20 ¹ /-0.5	+0.5/-20 ²	+20 ¹ /-0.5	+0.5/-20 ²	+2	+2/-20 ²		
16	50	2.4	52	102	15.5	65.5	116.3	168.3	13	9
	80			132		95.5		198.3		
	100			152		115.5		218.3		
	125			177		140.5		243.3		
	160			212		175.5		278.3		

∅	Stroke	D1 ∅	L1	L2	L3	L4	L5	L6	∅ 1	∅ 2
[mm]	[mm]	+0.1	+20 ¹ /-0.5	+0.5/-20 ²	+20 ¹ /-0.5	+0.5/-20 ²	+2	+2/-20 ²		
20	50	2.4	52	102	15.5	65.5	134.8	210.8	15	11
	80			132		95.5		240.8		
	100			152		115.5		260.8		
	125			177		140.5		285.8		
	160			212		175.5		320.8		
	200			252		215.5		360.8		

1) Precision stroke adjustment, retracted end position
 2) Precision stroke adjustment, advanced end position

Linear modules HMPL

Technical data

FESTO

Clamping unit HMPL-...-KP
not suitable for positioning

**Retrofit kit for clamping unit
BKP-HMPL-...**

The clamping unit can be ordered via the modular product system (code KP). The kit BKP-HMPL can be ordered for retrofitting.

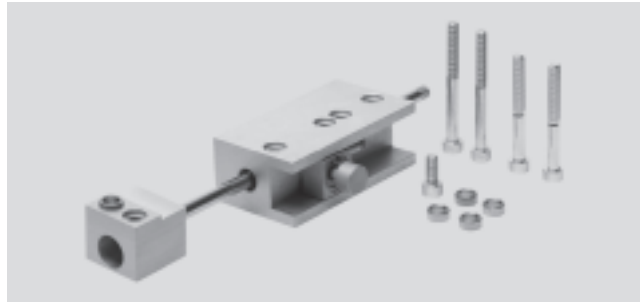

General technical data				
Piston Ø		12	16	20
Pneumatic connection ¹⁾		M3		
Max applied load, vertical	[kg]	1	2.5	5
Max. holding force	[N]	100		

1) Pneumatic connection is accomplished with a pre-assembled push-in fitting QSM-M3-4-I for 4 mm tubing.

Operating and environmental conditions				
Piston Ø		12	16	20
Operating pressure ¹⁾	[bar]	4 ... 8		
Ambient temperature	[°C]	0 ... +60		

1) Clamping is released within the operating pressure range.

Weights [g]				
Piston Ø		12	16	20
Product weight with stroke	30 mm	255	-	
	50 mm	260	270	
	80 mm	270	280	
	100 mm			
	125 mm		290	
	160 mm			
	200 mm			300
Moving load with stroke	30 mm	60	-	
	50 mm	65	74	
	80 mm	75	84	
	100 mm			
	125 mm		95	
	160 mm			
	200 mm			105

Linear modules HMPL

Technical data

Dimensions – Clamping unit

Download CAD Data → www.festo.com/us/cad

HMPL-...-KP (code KP)

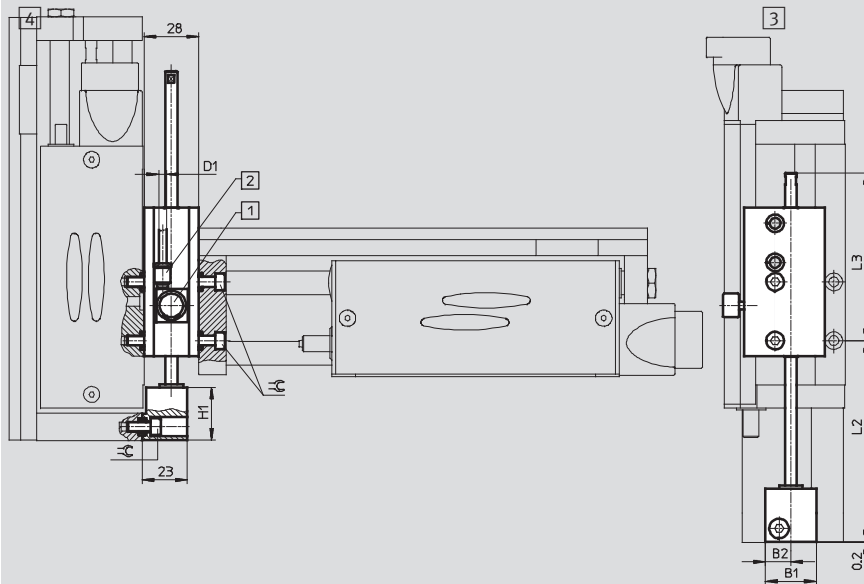

- 1 Manual override
- 2 M3 compressed air connection (push-in fitting QSM-M3-4-I for 4 mm tubing included)
- 3 Extended end position
- 4 Retracted end position

∅	Stroke	B1	B2	D1	L1	L2	L3	L4	H1	⊕
[mm]	[mm]			∅	+15 ¹ /-0.5	+0.5/-15 ¹	+15 ¹ /-0.5	+0.5/-15 ¹		
12	30	30	22	4	42.1	72.1	80	110	15.5	4
	50					92.1	85	135		
	80					122.1	105	185		
	100					142.1	85	185		

∅	Stroke	B1	B2	D1	L1	L2	L3	L4	H1	⊕
[mm]	[mm]			∅	+20 ¹ /-0.5	+0.5/-20 ¹	+20 ¹ /-0.5	+0.5/-20 ¹		
16	50	26	13	4	51.8	101.8	86.8	136.8	27	4
	80					131.8	106.8	186.8		
	100					151.8	86.8	186.8		
	125					176.8	111.8	236.8		
	160					211.8	76.8	236.8		

∅	Stroke	B1	B2	D1	L1	L2	L3	L4	H1	⊕
[mm]	[mm]			∅	+20 ¹ /-0.5	+0.5/-20 ¹	+20 ¹ /-0.5	+0.5/-20 ¹		
20	50	26	13	4	51.8	101.8	86.8	136.8	27	4
	80					131.8	106.8	186.8		
	100					151.8	86.8	186.8		
	125					176.8	111.8	236.8		
	160					211.8	76.8	236.8		
	200					251.8	86.8	286.8		

1) Stroke setting range of the HMPL axis

Linear modules HMPL

Technical data



Reinforcing plate HMPL-...-VP

Retrofit kit for reinforcing plate BVP-HMPL-...

The reinforcing plate can be ordered via the modular product system (code VP). The kit BVP-HMPL can be ordered for retrofitting.

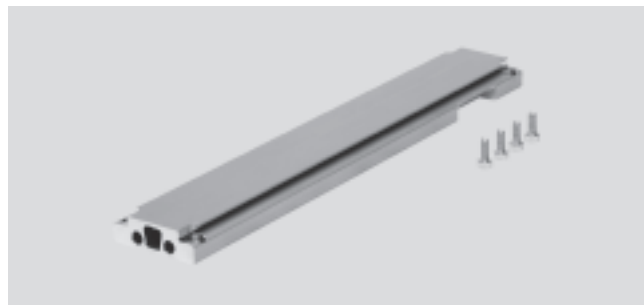

Dimensions – Reinforcing plate Download CAD Data → www.festo.com/us/cad

HMPL-...-VP (code VP)

- 1 Mounting screws
- 2 Space for tubing throughfeed
- 3 Suitable for dovetail clamping

∅	Stroke	B1	B2	B3	D1	D2	H1	H2	L1	Weight
[mm]	[mm]					∅				[g]
12	30	42	11	6.2	M4	4.2	14	10	171.6	177
	50								201.6	208
	80								261.6	272
	100								301.6	314

∅	Stroke	B1	B2	B3	D1	D2	H1	H2	L1	Weight
[mm]	[mm]					∅				[g]
16	50	45	10	7.6	M4	6	14	10	216.6	240
	80								266.6	297
	100								306.6	342
	125								356.6	398
	160								426.6	478

∅	Stroke	B1	B2	B3	D1	D2	H1	H2	L1	Weight
[mm]	[mm]					∅				[g]
20	50	52	12	8.4	M5	6	14	10	229.6	283
	80								266.6	343
	100								306.6	395
	125								356.6	457
	160								426.6	547
	200								506.6	648

Linear modules HMPL

Technical data



External passive intermediate position HMMP-...E

The intermediate position in the Z axis is approached with extended Y axis. A counter-stop for the stop element (in this case mounted on the reinforcing plate VP on the linear module HMPL) must be provided by the user.

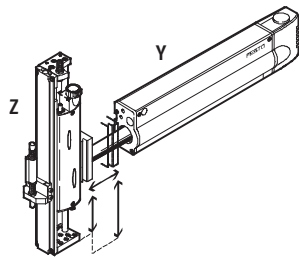

Dimensions – External passive intermediate position

Download CAD Data → www.festo.com/us/cad

HMMP-...-E

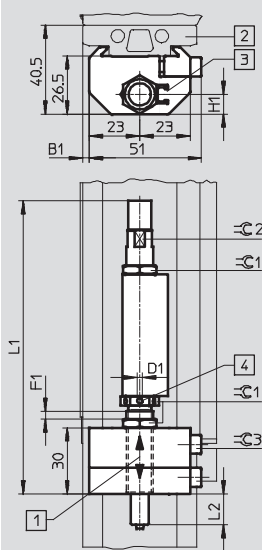

- 1 Stop position can be adjusted by sliding across the reinforcing plate. Precision end-position adjustment (F1) via thread on stop element
- 2 Reinforcing plate
- 3 Slot for proximity sensor SME-8/SMT-8
- 4 Drilled hole for precision end-position adjustment with internal hexagon socket

Type	B1	D1 +0.1	F1	H1	L1	L2	∅ 1	∅ 2	∅ 3	Weight [g]
HMMP-12-E	-1	2	15	7	97.4	8	10	7	4	115
HMMP-16-E	0.5	2.4	22	7	114.8	10	13	9	4	145
HMMP-20-E	4	2.4	35	9	133.3	14	15	11	4	205

Linear modules HMPL

Technical data

FESTO

Active intermediate position HMPL-...M

Retrofit kit for active intermediate position BM-HMPL-...

The active intermediate position can be ordered via the modular product system (code M). The kit BM-HMPL can be ordered for retrofitting.

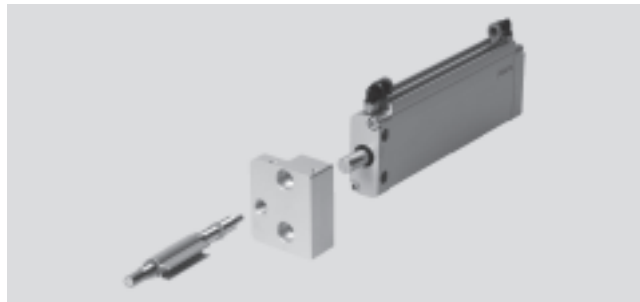

General technical data			
Piston Ø		12	16 20
Pneumatic connection		M5	
Selectable stroke range X for the intermediate position with stroke	30 mm	1 ... 29	–
	50 mm	1 ... 49	
	80 mm	1 ... 79	
	100 mm	1 ... 99	
	125 mm	–	1 ... 124
	160 mm		1 ... 159
	200 mm		– 1 ... 199
Setting range for the intermediate position	[mm]	±7.5 ¹⁾	±10 ¹⁾

1) Valid for stroke range 7.5 or 10 mm to max. stroke –7.5 or –10 mm.

Operating and environmental conditions			
Piston Ø		12	16 20
Operating pressure ¹⁾	[bar]	4 ... 8	
Ambient temperature ¹⁾	[°C]	0 ... +60	

1) Operating pressure of the mid-position cylinder must be greater than or equal to operating pressure of the linear module HMPL.

Weights [g]			
Piston Ø		12	16 20
Product weight with 0 mm stroke		420	700 840
Product weight per 10 mm stroke		18	24

 Note

The mid-position cylinder should be throttled during the following motion sequence: From HMPL advanced, to HMPL intermediate position.

Linear modules HMPL

Technical data

FESTO

Dimensions – Active intermediate position

Download CAD Data → www.festo.com/us/cad

HMPL-...M (code M)

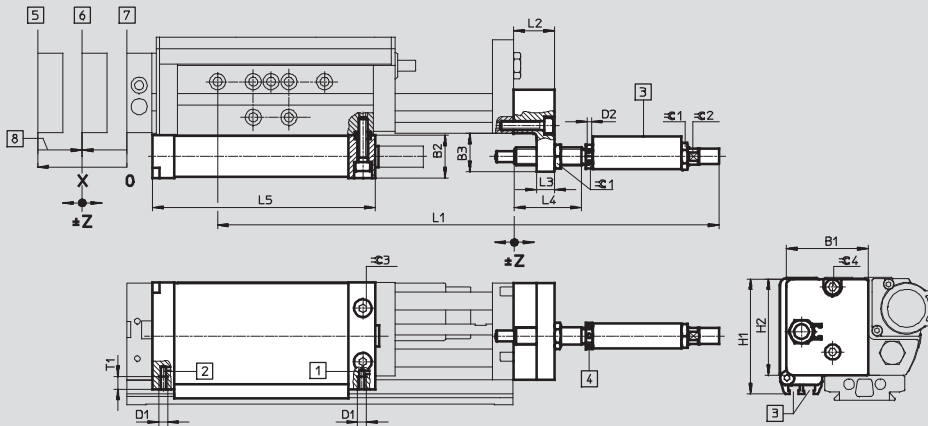

- 1 Supply port, retracting
- 2 Supply port, advancing
- 3 Slot for proximity sensor SME-8/SMT-8
- 4 Drilled hole for precision stroke adjustment with internal hex
- 5 Extended position (max. stroke)
- 6 Intermediate position
- 7 Retracted position
- 8 The mid-position cylinder should be throttled during the following motion sequence: From HMPL advanced, to HMPL intermediate position.

∅	Stroke	B1	B2	B3	D1	D2 ∅	H1	H2	L1	L2	L3	L4	L5	T1	≈C1	≈C2	≈C3	≈C4	Intermediate position Stroke X	Setting range Z ²⁾
[mm]	[mm]	±0.3	-0.6	±0.5		+0.1	±0.3	±0.3	+2/-15 ¹⁾	±0.2			+0.6							
12	30	38	20	17.5	M5	2	55	45	238	18	8	30	Stroke HMPL + 81.5 - X	6	10	7	3	4	1 ... 29	±7.5
	50								1 ... 49											
	80								1 ... 79											
	100								1 ... 99											

∅	Stroke	B1	B2	B3	D1	D2 ∅	H1	H2	L1	L2	L3	L4	L5	T1	≈C1	≈C2	≈C3	≈C4	Intermediate position Stroke X	Setting range Z ³⁾
[mm]	[mm]	±0.3	-0.6	±0.5		+0.1	±0.3	±0.3	+2/-20 ¹⁾	±0.2			+0.6							
16	50	46	24	21.5	M5	2.4	64.5	54	294	23	10	37	Stroke HMPL + 86 - X	7	13	9	4	4	1 ... 49	±10
	80								1 ... 79											
	100								1 ... 99											
	125								1 ... 124											
	160								1 ... 159											

∅	Stroke	B1	B2	B3	D1	D2 ∅	H1	H2	L1	L2	L3	L4	L5	T1	≈C1	≈C2	≈C3	≈C4	Intermediate position Stroke X	Setting range Z ³⁾
[mm]	[mm]	±0.3	-0.6	±0.5		+0.1	±0.3	±0.3	+2/-20 ¹⁾	±0.2			+0.6							
20	50	51.5	24	22	M5	2.4	64.5	61	321	23	10	37	Stroke HMPL + 86 - X	7	15	11	4	4	1 ... 49	±10
	80								1 ... 79											
	100								1 ... 99											
	125								1 ... 124											
	160								1 ... 159											
	200								1 ... 199											

1) Precision stroke adjustment, advanced end position
 2) Valid within a range of 7.5 mm to max. stroke -7.5 mm
 3) Valid within a range of 10 mm to max. stroke -10 mm
 X = Selected intermediate position

Linear modules HMPL

Technical data



Passive intermediate position HMMP-...-HMP

The intermediate position in the Z axis is approached with retracted Y axis. The counter-stop for the stop element (in this case mounted on the reinforcing plate VP on the linear module HMPL) is attached to the linear module HMP and is included in the scope of delivery.

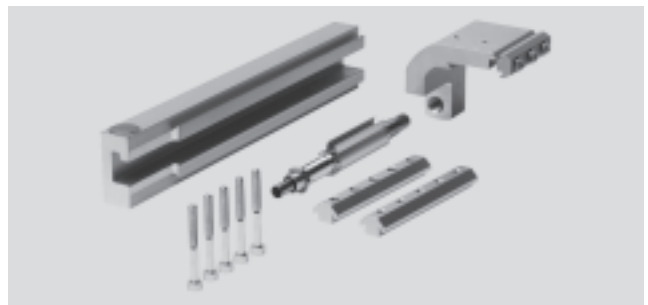
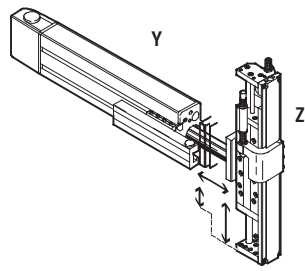

 - Note
For reasons of rigidity, the retracted end position may not be moved forward more than 50 mm.

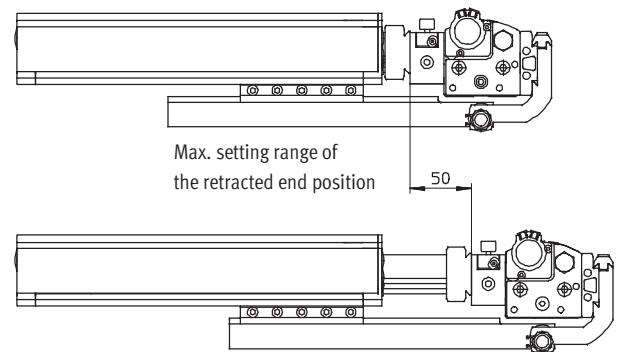

Linear modules HMPL

Technical data

Dimensions – Passive intermediate position

Download CAD Data → www.festo.com/us/cad

HMMP-...-HMP

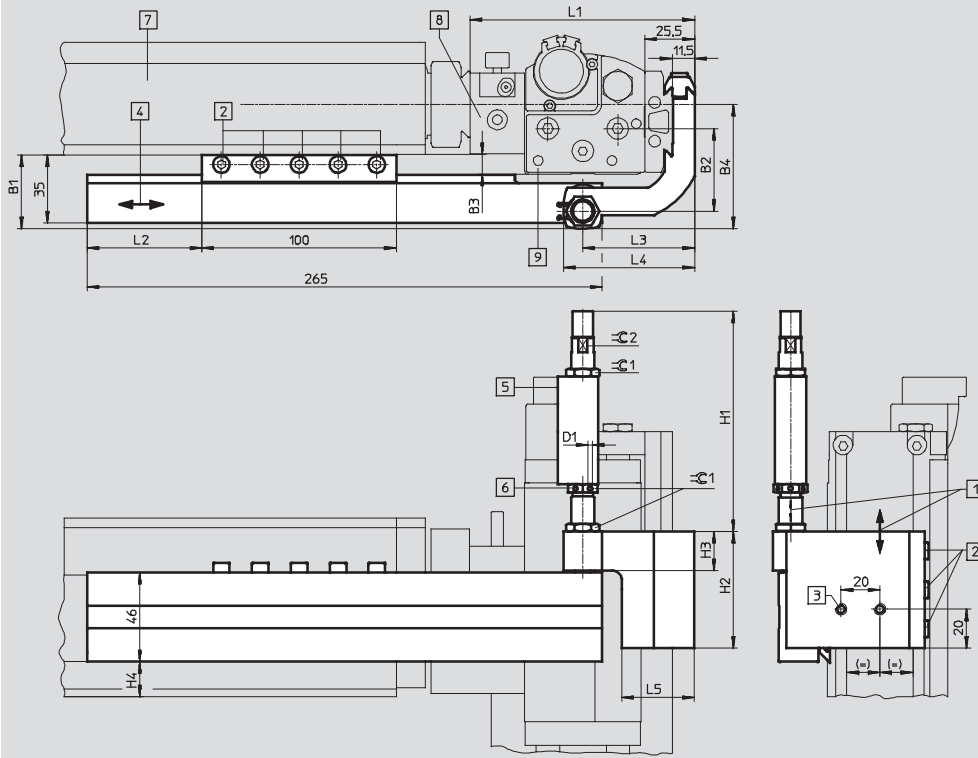

- 1 Stop position can be adjusted by sliding across the reinforcing plate
- 2 Clamping by means of M5 socket head screws with internal hexagon socket
- 3 M5 holes, 6 mm deep: for attaching adapter plate HMZAS or retaining clip MKRS
- 4 Horizontal adjusting range for stop position in the retracted end position
- 5 Slot for proximity sensor SME-8/SMT-8
- 6 Drilled hole for precision end-position adjustment with internal hexagon socket
- 7 Linear module HMP
- 8 Clamping unit HMPL-...-KP
- 9 Linear module HMPL

Type	Horizontal Y axis	Vertical Z axis	B1	B2	B3	B4	D1 ∅	H1	H2	H3	H4
HMMP-12-HMP	HMP-16	HMPL-12-...	26.5	35	0.5	52.5	2	82.4 +0.5/-12 ¹⁾	40	15	18
HMMP-16-HMP	HMP-16	HMPL-16-...	30.5	37	4	56.5	2.4	94.8 +0.5/-14 ¹⁾	60	20	18
	HMP-20		0		23.5						
HMMP-20-HMP	HMP-16	HMPL-20-...	38	42.5	10	64	2.4	113.3 +0.5/-14 ¹⁾	60	20	18
	HMP-20		6		23.5						

Type	Horizontal Y axis	Vertical Z axis	L1	L1 with KP	L2	L2 with KP	L3	L4	L5	∅ 1	∅ 2	Weight [g]
HMMP-12-HMP	HMP-16	HMPL-12-...	71.5	99.5	95	67	49.5	56.5	29.5	10	7	845
HMMP-16-HMP	HMP-16	HMPL-16-...	80.5	108.5	90	62	53.5	61.5	33.5	13	9	945
	HMP-20											
HMMP-20-HMP	HMP-16	HMPL-20-...	87.5	115.5	87	59	57.5	67.5	37.5	15	11	995
	HMP-20											

1) Setting range via stop element

Linear modules HMPL

Ordering data – Modular products



M Mandatory data					O Options						
Module No.	Drive function	Piston Ø	Stroke	Stop element	Reinforcement	Clamping unit	Active intermediate position	Proximity sensor	Accessories	Accessories	
191 181	HMPL	12	30 ... 200	AI	VP	KP	...M	2A1 2A2 2A3 2A4 2A5 2A6	ZUB	...H	
191 182		16		AE						...I	
191 183		20		...J ...K ...V ...Z							
Ordering example											
191 182	HMPL	- 16	- 100	- AI	- VP	- KP	-	- 2A1	- ZUB	- 2H512V	

Ordering table							
Size	12	16	20	Condi- tions	Code	Enter code	
M Module No.	191 181	191 182	191 183				
Drive function	Linear module				HMPL		HMPL
Piston Ø [mm]	12	16	20		-...		
Stroke [mm]	30	-	-		-30		
	50	50	50		-50		
	80	80	80		-80		
	100	100	100		-100		
	-	125	125		-125		
	-	160	160		-160		
	-	-	200		-200		
Stop element	Integrated				-AI		
	External				-AE		
O Reinforcement	Reinforcing plate (required for multi-axis operation)				-VP		
Clamping unit	Supplied separately				-KP		
Active intermediate position [mm]	1 ... 99	1 ... 159	1 ... 199	¹	-...M		
Proximity sensor, magnetic, assembled	With cable, 2.5 m				-2A1		
	Contactless, with cable, 2.5 m, NPN				-2A2		
	Contactless, with cable, 2.5 m, PNP				-2A3		
	With plug				-2A4		
	Contactless, with plug, NPN				-2A5		
	Contactless, with plug, PNP				-2A6		
Accessories	Supplied separately				ZUB-		ZUB-
Mounting bracket	Front plate PG21, 1 ... 10				...H		
Adapter	Dovetail adapter, basic profile, 1 ... 10				...I		
Clamping component	Dovetail clamping component, 1 ... 10				...J		
Stop bolt	1 ... 10				...K		
Cable with socket, 2.5 m	1 ... 10				...V		
Centring sleeves (pack of 10)	10, 20, 30, 40, 50, 60, 70, 80, 90				...Z		

¹ **M** The dimension selected must be at least 1 mm smaller than the specified stroke length.

Transfer order code

	HMPL	-		-		-		-		-		-		ZUB	-	
--	-------------	---	--	---	--	---	--	---	--	---	--	---	--	------------	---	--

Linear modules HMPL

Technical data

FESTO

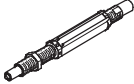
Ordering data – Stop element			
	For Ø [mm]	Part No.	Type
	12	192 968	YSRWJ-5-8-A
	16	192 967	YSRWJ-7-10-A
	20	192 966	YSRWJ-8-14-A

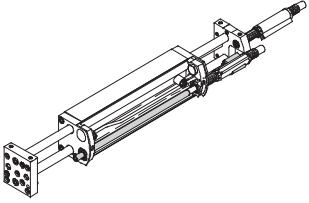
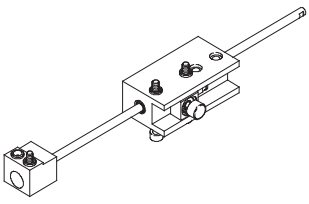
Ordering data – Retrofit kits			
	For Ø [mm]	Stroke [mm]	Part No. Type
External stop element (scope of delivery shown against a grey background)			
	12	30	193 765 BAE-HMPL-12-30
		50	193 766 BAE-HMPL-12-50
		80	193 767 BAE-HMPL-12-80
		100	193 768 BAE-HMPL-12-100
	16	50	193 769 BAE-HMPL-16-50
		80	193 770 BAE-HMPL-16-80
		100	193 771 BAE-HMPL-16-100
		125	193 772 BAE-HMPL-16-125
		160	193 773 BAE-HMPL-16-160
	20	50	193 774 BAE-HMPL-20-50
		80	193 775 BAE-HMPL-20-80
		100	193 776 BAE-HMPL-20-100
		125	193 777 BAE-HMPL-20-125
160		193 778 BAE-HMPL-20-160	
200		193 779 BAE-HMPL-20-200	
Clamping unit			
	12	30	193 110 BKP-HMPL-12-30
		50	193 111 BKP-HMPL-12-50
		80/100	193 112 BKP-HMPL-12-80/100
	16	50	193 114 BKP-HMPL-16/20-50
		80/100	193 115 BKP-HMPL-16/20-80/100
		125/160	193 116 BKP-HMPL-16/20-125/160
	20	50	193 114 BKP-HMPL-16/20-50
		80/100	193 115 BKP-HMPL-16/20-80/100
		125/160	193 116 BKP-HMPL-16/20-125/160
		200	193 117 BKP-HMPL-20-200

Linear modules HMPL

Technical data

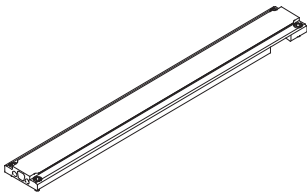
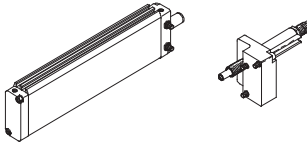
Ordering data – Retrofit kits				
	For Ø [mm]	Stroke [mm]	Part No.	Type
Reinforcing plate				
	12	30	193 369	BVP-HMPL-12-30
		50	193 370	BVP-HMPL-12-50
		80	193 371	BVP-HMPL-12-80
		100	193 372	BVP-HMPL-12-100
	16	50	193 364	BVP-HMPL-16-50
		80	193 365	BVP-HMPL-16-80
		100	193 366	BVP-HMPL-16-100
		125	193 367	BVP-HMPL-16-125
		160	193 368	BVP-HMPL-16-160
	20	50	193 358	BVP-HMPL-20-50
		80	193 359	BVP-HMPL-20-80
		100	193 360	BVP-HMPL-20-100
		125	193 361	BVP-HMPL-20-125
	200	193 363	BVP-HMPL-20-200	
Active intermediate position³⁾				
	12	1 ... 99 (up to the intermediate position)	193 022	BM-HMPL-12-... ¹⁾ -... ²⁾
	16	1 ... 159 (up to the intermediate position)	193 021	BM-HMPL-16-... ¹⁾ -... ²⁾
	20	1 ... 199 (up to the intermediate position)	193 020	BM-HMPL-20-... ¹⁾ -... ²⁾
Ordering example				
Existing: HMPL-16-100-AI Desired intermediate position: Advance 25 mm Required kit: 193 021 BM-HMPL-16-100-25M				

1) Indicate stroke length of the existing HMPL linear module.

2) Indicate desired intermediate position measured from the retracted end position.

3) The mid-position cylinder should be throttled during the following motion sequence: From HMPL advanced, to HMPL intermediate position.

Linear modules HMPL

Technical data



Ordering data – External passive intermediate position

Combined with linear module HMP

The intermediate position in the Z axis is approached with extended Y axis. A counter-stop for the stop element (in this case mounted on the reinforcing plate VP on the linear module HMPL) must be provided by the user.

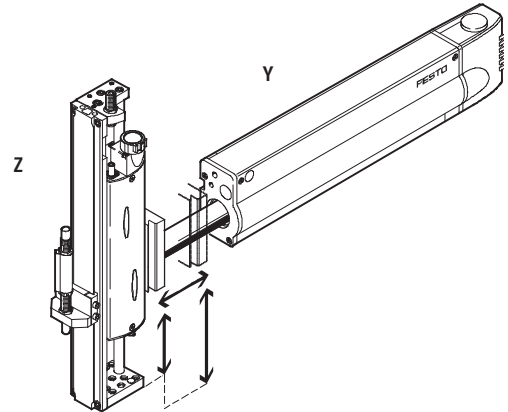

Linear module ∅ [mm]	Z axis					
	HMPL-12-... ¹⁾		HMPL-16-... ¹⁾		HMPL-20-... ¹⁾	
	Part No.	Type	Part No.	Type	Part No.	Type
Y axis						
HMP-16	196 168	HMMP-12-E	196 167	HMMP-16-E	196 166	HMMP-20-E
HMP-20	-		-		-	
HMP-25	-		-		-	
HMPL-12	196 168	HMMP-12-E	196 167	HMMP-16-E	-	
HMPL-16	-		-		-	
HMPL-20	-		-		196 166	HMMP-20-E

1) Reinforcing plate VP is required for this function, or, in the event of retrofitting, kit BVP-HMPL-...

Ordering data – Passive intermediate position

Combined with linear module HMP

The intermediate position in the Z axis is approached with retracted Y axis. The counter-stop for the stop element (in this case mounted on the reinforcing plate VP on the linear module HMPL) is attached to the linear module HMP and is included in the scope of delivery.

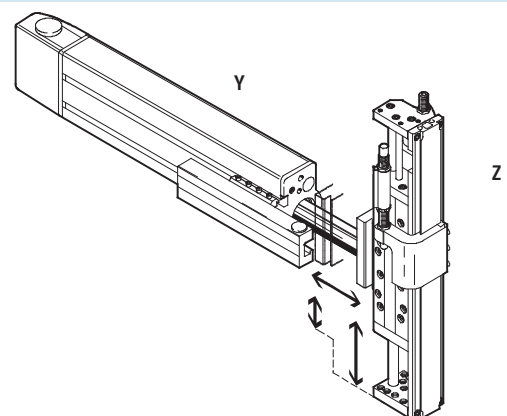

Linear module ∅ [mm]	Z axis					
	HMPL-12-... ¹⁾		HMPL-16-... ¹⁾		HMPL-20-... ¹⁾	
	Part No.	Type	Part No.	Type	Part No.	Type
Y axis						
HMP-16	193 726	HMMP-12-HMP	193 725	HMMP-16-HMP	193 724	HMMP-20-HMP
HMP-20	-		-		-	
HMP-25	-		-		-	

1) Reinforcing plate VP is required for this function, or, in the event of retrofitting, kit BVP-HMPL-...

Linear modules HMPL

Accessories

FESTO

Dovetail adapter HMPL-...-I (code I)

Material:
Wrought aluminium alloy
Free of copper, PTFE and silicone

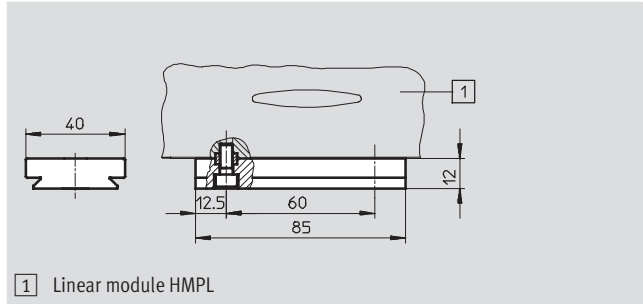

1 Linear module HMPL

Dimensions and ordering data		
For Ø	Part No.	Type
[mm]		
12 ... 20	193 923	HMSV-46

Clamping component HMPL-J (code J)

Material:
Wrought aluminium alloy
Free of copper, PTFE and silicone

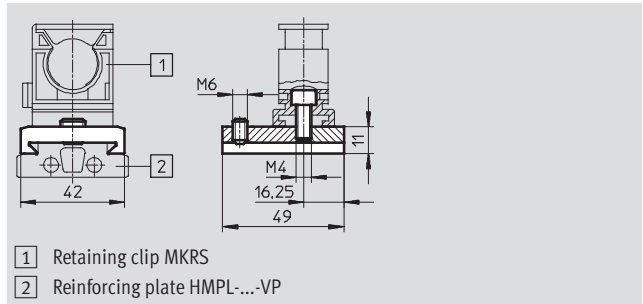

1 Retaining clip MKRS
2 Reinforcing plate HMPL-...-VP

Dimensions and ordering data		
For Ø	Part No.	Type
[mm]		
12 ... 20	193 126	HMPL-20-J

Stop bolt HMPL-...-K (code K)

Material:
Galvanised steel
Free of copper, PTFE and silicone

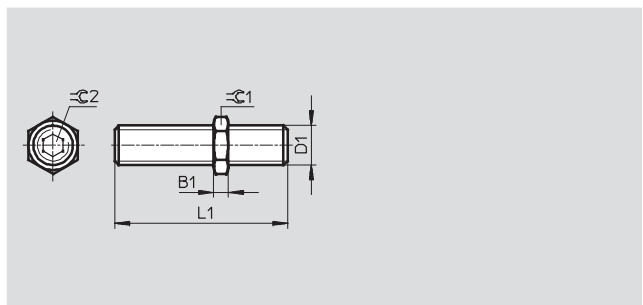



Dimensions and ordering data						
For Ø	B1	D1	L1	C1	C2	Part No. Type
[mm]						
12	3	M8x1	35	10	4	192 683 HMPL-12-K
16	3.5	M10x1	40	13	5	192 684 HMPL-16-K
20	4	M12x1	43	15	6	192 685 HMPL-20-K



Linear modules HMPL



Accessories

FESTO

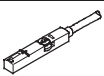
Ordering data						
	For piston Ø [mm]	Remarks	Order code	Part No.	Type	PU ¹⁾
Centring sleeve ZBH			Technical data → Internet: zbh			
	12 ... 20	For front plate	Z	150 927	ZBH-9	10
Inscription label SBS			Technical data → Internet: sbs			
	12 ... 20	For labelling the linear module	-	193 125	SBS-8x10	44

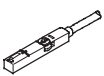
1) Packaging unit quantity

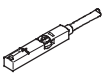

Ordering data – Proximity sensors for T-slot, magneto-resistive						Technical data → Internet: smt
	Type of mounting	Switch output	Electrical connection	Cable length [m]	Part No.	Type
N/O contact						
	Insertable in the slot from above, flush with cylinder profile	PNP	Cable, 3-wire	2.5	543 867	SMT-8M-PS-24V-K-2,5-OE
			Plug M8x1, 3-pin	0.3	543 866	SMT-8M-PS-24V-K-0,3-M8D
			Plug M12x1, 3-pin	0.3	543 869	SMT-8M-PS-24V-K-0,3-M12
	Insertable in the slot lengthwise, flush with the cylinder profile	PNP	Cable, 3-wire	2.5	543 870	SMT-8M-NS-24V-K-2,5-OE
			Plug M8x1, 3-pin	0.3	543 871	SMT-8M-NS-24V-K-0,3-M8D
N/C contact						
	Insertable in the slot from above, flush with cylinder profile	PNP	Cable, 3-wire	7.5	543 873	SMT-8M-PO-24V-K7,5-OE

Ordering data – Proximity sensors for T-slot, magnetic reed						Technical data → Internet: sme
	Type of mounting	Switch output	Electrical connection	Cable length [m]	Part No.	Type
N/O contact						
	Insertable in the slot from above, flush with cylinder profile	Contacting	Cable, 3-wire	2.5	543 862	SME-8M-DS-24V-K-2,5-OE
				5.0	543 863	SME-8M-DS-24V-K-5,0-OE
			Cable, 3-wire	2.5	543 872	SME-8M-ZS-24V-K-2,5-OE
			Plug M8x1, 3-pin	0.3	543 861	SME-8M-DS-24V-K-0,3-M8D
	Insertable in the slot lengthwise, flush with the cylinder profile	Contacting	Cable, 3-wire	2.5	150 855	SME-8-K-LED-24
			Plug M8x1, 3-pin	0.3	150 857	SME-8-S-LED-24
N/C contact						
	Insertable in the slot lengthwise, flush with the cylinder profile	Contacting	Cable, 3-wire	7.5	160 251	SME-8-O-K-LED-24

Linear modules HMPL

Accessories



Ordering data – Connecting cables				Technical data → Internet: nebu	
	Electrical connection, left	Electrical connection, right	Cable length [m]	Part No.	Type
	Straight socket, M8x1, 3-pin	Cable, open end, 3-wire	2.5	541 333	NEBU-M8G3-K-2.5-LE3
			5	541 334	NEBU-M8G3-K-5-LE3
	Straight socket, M12x1, 5-pin	Cable, open end, 3-wire	2.5	541 363	NEBU-M12G5-K-2.5-LE3
			5	541 364	NEBU-M12G5-K-5-LE3
	Angled socket, M8x1, 3-pin	Cable, open end, 3-wire	2.5	541 338	NEBU-M8W3-K-2.5-LE3
			5	541 341	NEBU-M8W3-K-5-LE3
	Angled socket, M12x1, 5-pin	Cable, open end, 3-wire	2.5	541 367	NEBU-M12W5-K-2.5-LE3
			5	541 370	NEBU-M12W5-K-5-LE3

Product Range and Company Overview

A Complete Suite of Automation Services

Our experienced engineers provide complete support at every stage of your development process, including: conceptualization, analysis, engineering, design, assembly, documentation, validation, and production.



Custom Automation Components
Complete custom engineered solutions



Custom Control Cabinets
Comprehensive engineering support and on-site services



Complete Systems
Shipment, stocking and storage services

The Broadest Range of Automation Components

With a comprehensive line of more than 30,000 automation components, Festo is capable of solving the most complex automation requirements.



Electromechanical
Electromechanical actuators, motors, controllers & drives



Pneumatics
Pneumatic linear and rotary actuators, valves, and air supply



PLCs and I/O Devices
PLC's, operator interfaces, sensors and I/O devices

Supporting Advanced Automation... As No One Else Can!

Festo is a leading global manufacturer of pneumatic and electromechanical systems, components and controls for industrial automation, with more than 12,000 employees in 56 national headquarters serving more than 180 countries. For more than 80 years, Festo has continuously elevated the state of manufacturing with innovations and optimized motion control solutions that deliver higher performing, more profitable automated manufacturing and processing equipment. Our dedication to the advancement of automation extends beyond technology to the education and development of current and future automation and robotics designers with simulation tools, teaching programs, and on-site services.

Quality Assurance, ISO 9001 and ISO 14001 Certifications

Festo Corporation is committed to supply all Festo products and services that will meet or exceed our customers' requirements in product quality, delivery, customer service and satisfaction.

To meet this commitment, we strive to ensure a consistent, integrated, and systematic approach to management that will meet or exceed the requirements of the ISO 9001 standard for Quality Management and the ISO 14001 standard for Environmental Management.



© Copyright 2008, Festo Corporation. While every effort is made to ensure that all dimensions and specifications are correct, Festo cannot guarantee that publications are completely free of any error, in particular typing or printing errors. Accordingly, Festo cannot be held responsible for the same. For Liability and Warranty conditions, refer to our "Terms and Conditions of Sale", available from your local Festo office. All rights reserved. No part of this publication may be reproduced, distributed, or transmitted in any form or by any means, electronic, mechanical, photocopying or otherwise, without the prior written permission of Festo. All technical data subject to change according to technical update.



Printed on recycled paper at New Horizon Graphic, Inc., FSC certified as an environmentally friendly printing plant.

Festo North America

Festo Regional Contact Center

5300 Explorer Drive
Mississauga, Ontario L4W 5G4
Canada

USA Customers:

For ordering assistance,

Call: 1.800.99.FESTO (1.800.993.3786)

Fax: 1.800.96.FESTO (1.800.963.3786)

Email: customer.service@us.festo.com

For technical support,

Call: 1.866.GO.FESTO (1.866.463.3786)

Fax: 1.800.96.FESTO (1.800.963.3786)

Email: product.support@us.festo.com

Canadian Customers:

Call: 1.877.GO.FESTO (1.877.463.3786)

Fax: 1.877.FX.FESTO (1.877.393.3786)

Email: festo.canada@ca.festo.com

USA Headquarters

Festo Corporation
395 Moreland Road
P.O. Box 18023
Hauppauge, NY 11788, USA
www.festo.com/us

USA Sales Offices

Appleton

North 922 Tower View Drive, Suite N
Greenville, WI 54942, USA

Boston

120 Presidential Way, Suite 330
Woburn, MA 01801, USA

Chicago

1441 East Business Center Drive
Mt. Prospect, IL 60056, USA

Dallas

1825 Lakeway Drive, Suite 600
Lewisville, TX 75057, USA

Detroit – Automotive Engineering Center

2601 Cambridge Court, Suite 320
Auburn Hills, MI 48326, USA

New York

395 Moreland Road
Hauppauge, NY 11788, USA

Silicon Valley

4935 Southfront Road, Suite F
Livermore, CA 94550, USA

United States



USA Headquarters, East: Festo Corp., 395 Moreland Road, Hauppauge, NY 11788

Phone: 1.631.435.0800; Fax: 1.631.435.8026;

Email: info@festo-usa.com

www.festo.com/us

Canada



Headquarters: Festo Inc., 5300 Explorer Drive, Mississauga, Ontario L4W 5G4

Phone: 1.905.624.9000; Fax: 1.905.624.9001;

Email: festo.canada@ca.festo.com

www.festo.ca

Mexico



Headquarters: Festo Pneumatic, S.A., Av. Ceylán 3, Col. Tequesquahuac,
54020 Tlalneantla, Edo. de México

Phone: 011 52 [55] 53 21 66 00; Fax: 011 52 [55] 53 21 66 65;

Email: festo.mexico@mx.festo.com

www.festo.com/mx

Central USA

Festo Corporation
1441 East Business
Center Drive
Mt. Prospect, IL 60056, USA
Phone: 1.847.759.2600
Fax: 1.847.768.9480



Western USA

Festo Corporation
4935 Southfront Road,
Suite F
Livermore, CA 94550, USA
Phone: 1.925.371.1099
Fax: 1.925.245.1286



Festo Worldwide

Argentina Australia Austria Belarus Belgium Brazil Bulgaria Canada Chile China Colombia Croatia Czech Republic Denmark
Estonia Finland France Germany Great Britain Greece Hong Kong Hungary India Indonesia Iran Ireland Israel Italy Japan Latvia
Lithuania Malaysia Mexico Netherlands New Zealand Norway Peru Philippines Poland Romania Russia Serbia Singapore
Slovakia Slovenia South Africa South Korea Spain Sweden Switzerland Taiwan Thailand Turkey Ukraine United States Venezuela

www.festo.com