

Parallel kits EAMM-U

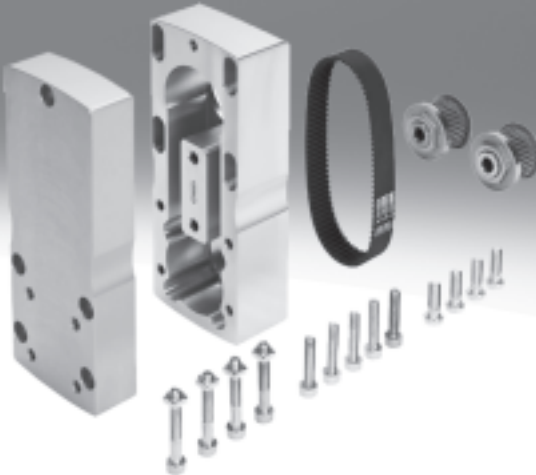

Parallel kits EAMM-U

Key features

FESTO

At a glance

Parallel kits EAMM-U



- Space-saving gravity die-cast housing

Parallel kits EAMM-U

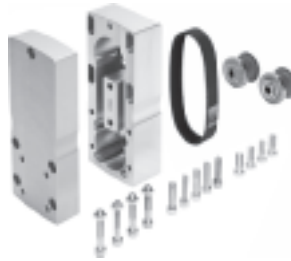

- Increased housing rigidity
- More flexible motor connection possible
- Optionally with protection to IP65
- Use in combination with third-party motors on request

Counter bearing EAMG

The counter bearing cannot be used in combination with this parallel kit.

Counter bearing EAMG

→ 17



The counter bearing in combination with the additional clamping sleeve EAMH-...-P enables axis or motor shafts to be braced by means of a needle roller bearing against the transverse forces generated by a toothed belt.

Clamping sleeve EAMH-...-P

The clamping sleeve cannot be used in combination with this parallel kit.

Clamping sleeve EAMH-...-P

→ 17



To retrofit the counter bearing, the clamping sleeve without trunnion contained as standard in the parallel kit must be replaced by the clamping sleeve EAMH-...-P with integrated trunnion.

Clamping component EADT

The clamping component cannot be used in combination with this parallel kit.

Clamping component EADT

→ 18



For adjusting the toothed belt pretension with EAMM-U-110 and EAMM-U-145. The motor is pushed away from the axis mechanism by turning the clamping component secured in a hole in the housing (the motor can be moved in a slot for this purpose). This enables high toothed belt pretension forces to be generated with low torques at the clamping component.

Parallel kits EAMM-U

Product range overview

Permissible axis/motor combinations with spindle axis DGE-SP

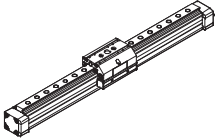

Properties of the kits

- Space-saving gravity die-cast housing



Motor Type	Parallel kit	
	Part No.	Type
DGE-25		
With servo motor		
EMMS-AS-55-...	543230	EAMM-U-E32-55A
With motor unit		
MTR-DCI-42S-...-G07	543228	EAMM-U-E32-42B
MTR-DCI-42S-...-G14	543229	EAMM-U-E32-42C
DGE-40		
With servo motor		
EMMS-AS-70-...	543234	EAMM-U-E48-70A
With motor unit		
MTR-DCI-52S-...-G07	543232	EAMM-U-E48-52B
MTR-DCI-52S-...-G14	543233	EAMM-U-E48-52C

Permissible axis/motor combinations with positioning axis DMES

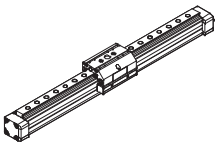

Properties of the kits

- Space-saving gravity die-cast housing



Motor Type	Parallel kit	
	Part No.	Type
DMES-18		
With servo motor		
EMMS-AS-40-...	543226	EAMM-U-E24-40A
With motor unit		
MTR-DCI-32S-...	543225	EAMM-U-E24-32B
DMES-25		
With servo motor		
EMMS-AS-55-...	543230	EAMM-U-E32-55A
With motor unit		
MTR-DCI-42S-...-G7	543228	EAMM-U-E32-42B
MTR-DCI-42S-...-G14	543229	EAMM-U-E32-42C
DMES-40		
With servo motor		
EMMS-AS-70-...	543234	EAMM-U-E48-70A
With motor unit		
MTR-DCI-52S-...-G7	543232	EAMM-U-E48-52B
MTR-DCI-52S-...-G14	543233	EAMM-U-E48-52C

Note

At ambient temperatures below room temperature, the frictional torques increase in the case of the DMES-...-GF (plain-bearing guide). The maximum feed force of the axis may not be reached depending on the combination of motor/motor unit and positioning axis.

The respective no-load driving torque of the kit must be taken into consideration when using parallel kits.

Parallel kits EAMM-U

Product range overview



Permissible axis/motor combinations with electric cylinder DNCE

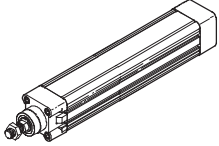

Properties of the kits

- Space-saving gravity die-cast housing



Properties of the kits

- Increased housing rigidity
- More flexible motor connection possible
- Optionally with protection to IP65
- Use in combination with third-party motors on request

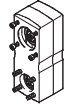

Motor	Parallel kit	
Type	Part No.	Type
DNCE-32		
With servo motor		
EMMS-AS-40-...	543150	EAMM-U-D32-40A
With motor unit		
MTR-DCI-32S-...	543152	EAMM-U-D32-32B
DNCE-40		
With servo motor		
EMMS-AS-55-...	543157	EAMM-U-D40-55A
With motor unit		
MTR-DCI-42S-...-G7	543159	EAMM-U-D40-42B
MTR-DCI-42S-...-G14	543160	EAMM-U-D40-42C
DNCE-63		
With servo motor		
EMMS-AS-70-...	543165	EAMM-U-D60-70A
With motor unit		
MTR-DCI-52S-...-G7	543167	EAMM-U-D60-52B
MTR-DCI-52S-...-G14	543168	EAMM-U-D60-52C

Note

The motor unit MTR-DCI may only be used in combination with the electric cylinder DNCE-...-LS (lead screw).

The maximum feed force of the cylinder may not be reached depending on the combination of motor/motor unit and electric cylinder.

The respective no-load driving torque of the kit must be taken into consideration when using parallel kits.

Motor	Parallel kit	
Type	Part No.	Type
DNCE-32		
With servo motor		
EMMS-AS-40-...	1201591	EAMM-U-50-D32-40A-78
	1202302	EAMM-U-50-D32-40A-78-S1 ¹⁾
EMMS-AS-55-...	1210126	EAMM-U-60-D32-55A-91
	1210450	EAMM-U-60-D32-55A-91-S1 ¹⁾
With stepper motor		
EMMS-ST-42-...	1201607	EAMM-U-50-D32-42A-78
	1202312	EAMM-U-50-D32-42A-78-S1 ¹⁾
EMMS-ST-57-...	1210419	EAMM-U-60-D32-57A-91
	1210453	EAMM-U-60-D32-57A-91-S1 ¹⁾
DNCE-40		
With servo motor		
EMMS-AS-55-...	1210438	EAMM-U-60-D40-55A-91
	1210458	EAMM-U-60-D40-55A-91-S1 ¹⁾
EMMS-AS-70-...	1212826	EAMM-U-86-D40-70A-102
	1212854	EAMM-U-86-D40-70A-102-S1 ¹⁾
With stepper motor		
EMMS-ST-57-...	1210442	EAMM-U-60-D40-57A-91
	1210462	EAMM-U-60-D40-57A-91-S1 ¹⁾
EMMS-ST-87-...	1215802	EAMM-U-86-D40-87A-102
	1215814	EAMM-U-86-D40-87A-102-S1 ¹⁾
DNCE-63		
With servo motor		
EMMS-AS-70-...	1212477	EAMM-U-86-D60-70A-102
	1212835	EAMM-U-86-D60-70A-102-S1 ¹⁾
EMMS-AS-100-...	1202436	EAMM-U-110-D60-100A-120
	1203112	EAMM-U-110-D60-100A-120-S1 ¹⁾
With stepper motor		
EMMS-ST-87-...	1215784	EAMM-U-86-D60-87A-102
	1215810	EAMM-U-86-D60-87A-102-S1 ¹⁾

1) With protection class IP65

Note

Clamping component EADT for adjusting the toothed belt pretension with EAMM-U-110 → 18

Parallel kits EAMM-U

Product range overview

Permissible axis/motor combinations with spindle axis EGC-BS

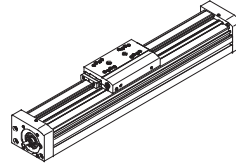

Properties of the kits

- Increased housing rigidity
- More flexible motor connection possible
- Use in combination with third-party motors on request

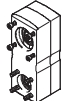

Motor	Parallel kit	
Type	Part No.	Type
EGC-70-...-BS		
With servo motor		
EMMS-AS-40-...	1217708	EAMM-U-50-S38-40A-78
EMMS-AS-55-...	1218538	EAMM-U-60-S38-55A-91
With stepper motor		
EMMS-ST-42-...	1217945	EAMM-U-50-S38-42A-78
EMMS-ST-57-...	1218568	EAMM-U-60-S38-57A-91
EGC-80-...-BS		
With servo motor		
EMMS-AS-55-...	1219370	EAMM-U-60-S48-55A-91
EMMS-AS-70-...	1217689	EAMM-U-86-S48-70A-102
With stepper motor		
EMMS-ST-57-...	1219379	EAMM-U-60-S48-57A-91
EMMS-ST-87-...	1217604	EAMM-U-86-S48-87A-177
EGC-120-...-BS		
With servo motor		
EMMS-AS-70-...	1217543	EAMM-U-86-S62-70A-177
EMMS-AS-100-...	1217381	EAMM-U-110-S62-100A-207
EMMS-AS-140-...	1219440	EAMM-U-145-S62-140A-288
With stepper motor		
EMMS-ST-87-...	1217373	EAMM-U-86-S62-87A-177
EGC-185-...-BS		
With servo motor		
EMMS-AS-100-...	1220656	EAMM-U-110-S95-100A-207
EMMS-AS-140-...	1220582	EAMM-U-145-S95-140A-288

Note

Clamping component EADT for adjusting the toothed belt pretension with EAMM-U-110 and EAMM-U-145 → 18

Parallel kits EAMM-U

Product range overview

Permissible axis/motor combinations with mini slide EGSL

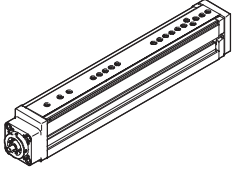

Properties of the kits

- Space-saving gravity die-cast housing



Motor	Parallel kit	
Type	Part No.	Type
EGSL-45		
With servo motor		
EMMS-AS-40-...	543150	EAMM-U-D32-40A
EGSL-55		
With servo motor		
EMMS-AS-55-...	543157	EAMM-U-D40-55A
EGSL-75		
With servo motor		
EMMS-AS-70-...	543165	EAMM-U-D60-70A

Properties of the kits

- Increased housing rigidity
- More flexible motor connection possible
- Use in combination with third-party motors on request

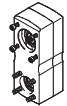

Motor	Parallel kit	
Type	Part No.	Type
EGSL-45		
With servo motor		
EMMS-AS-40-...	1201591	EAMM-U-50-D32-40A-78
EMMS-AS-55-...	1210126	EAMM-U-60-D32-55A-91
With stepper motor		
EMMS-ST-42-...	1201607	EAMM-U-50-D32-42A-78
EMMS-ST-57-...	1210419	EAMM-U-60-D32-57A-91
EGSL-55		
With servo motor		
EMMS-AS-55-...	1210438	EAMM-U-60-D40-55A-91
EMMS-AS-70-...	1212826	EAMM-U-86-D40-70A-102
With stepper motor		
EMMS-ST-57-...	1210442	EAMM-U-60-D40-57A-91
EMMS-ST-87-...	1215802	EAMM-U-86-D40-87A-102
EGSL-75		
With servo motor		
EMMS-AS-70-...	1212477	EAMM-U-86-D60-70A-102
EMMS-AS-100-...	1202436	EAMM-U-110-D60-100A-120
With stepper motor		
EMMS-ST-87-...	1215784	EAMM-U-86-D60-87A-102

Note

Clamping component EADT for adjusting the toothed belt pretension with EAMM-U-110 → 18

Parallel kits EAMM-U

Product range overview

Permissible axis/motor combinations with cantilever axis EGSA

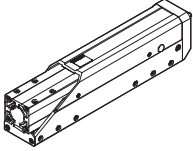

Properties of the kits

- Space-saving machined housing



Motor	Parallel kit	
Type	Part No.	Type
EGSA-50		
With servo motor		
EMMS-AS-40-...	559785	EAMM-U-A19-40A
EGSA-60		
With servo motor		
EMMS-AS-55-...	559786	EAMM-U-A22-55A
EMMS-AS-70-...	559787	EAMM-U-A22-70A

Permissible axis/motor combinations with rotary/lifting module EHMB

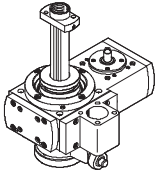

Properties of the kits

- Space-saving gravity die-cast housing



Motor	Parallel kit	
Type	Part No.	Type
EHMB-20/-25 with DNCE-32		
With servo motor		
EMMS-AS-40-...	543150	EAMM-U-D32-40A
With motor unit		
MTR-DCI-32S-...	543152	EAMM-U-D32-32B
EHMB-32 with DNCE-40		
With servo motor		
EMMS-AS-55-...	543157	EAMM-U-D40-55A
With motor unit		
MTR-DCI-42S-...-G7	543159	EAMM-U-D40-42B
MTR-DCI-42S-...-G14	543160	EAMM-U-D40-42C

Note

The motor unit MTR-DCI may only be used in combination with the electric cylinder DNCE-...-LS (lead screw).

The maximum feed force of the cylinder may not be reached depending on the combination of motor/motor unit and electric cylinder.

Properties of the kits

- Increased housing rigidity
- More flexible motor connection possible
- Use in combination with third-party motors on request

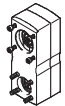

Motor	Parallel kit	
Type	Part No.	Type
EHMB-20/-25 with DNCE-32		
With servo motor		
EMMS-AS-40-...	1201591	EAMM-U-50-D32-40A-78
EMMS-AS-55-...	1210126	EAMM-U-60-D32-55A-91
With stepper motor		
EMMS-ST-42-...	1201607	EAMM-U-50-D32-42A-78
EMMS-ST-57-...	1210419	EAMM-U-60-D32-57A-91
EHMB-32 with DNCE-40		
With servo motor		
EMMS-AS-55-...	1210438	EAMM-U-60-D40-55A-91
EMMS-AS-70-...	1212826	EAMM-U-86-D40-70A-102
With stepper motor		
EMMS-ST-57-...	1210442	EAMM-U-60-D40-57A-91
EMMS-ST-87-...	1215802	EAMM-U-86-D40-87A-102

Parallel kits EAMM-U

Type codes

Properties of the kits

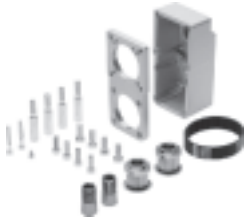

- Space-saving gravity die-cast housing

EAMM		U	D32	40A
Type				
EAMM	Kit			
Motor configuration				
U	Parallel			
Axis mechanism interface				
Motor interface				

Properties of the kits

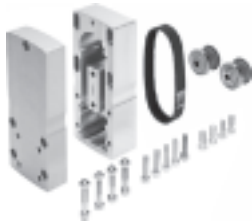

- Increased housing rigidity
- More flexible motor connection possible
- Optionally with protection to IP65
- Use in combination with third-party motors on request

EAMM		U	50	D32	40A	78	
Type							
EAMM	Kit						
Motor configuration							
U	Parallel						
Size							
Axis mechanism interface							
Motor interface							
Centre distance							
Special design							
S1	Protection class IP65						

Parallel kits EAMM-U

Technical data

Properties:

- Space-saving gravity die-cast housing

Materials:

Housing: Gravity die-cast aluminium
 Clamping component, clamping sleeve, toothed belt pulley: Corrosion-resistant steel
 Toothed belt: Polychloroprene
 Screws: Galvanised steel



General technical data									
Type	For axis	Transferable torque [Nm]	Mass moment of inertia [kgmm ²]	Max. rotational speed [rpm]	No-load driving torque [Nm]	Weight [g]	Protection class ¹⁾	→ Page	
EAMM-U-A19-40A	EGSA	1	2.87	6,000	0.05	270	IP40	16	
EAMM-U-A22-55A	EGSA	3	9.63	4,000	0.1	410	IP40		
EAMM-U-A22-70A	EGSA	5.5	10.1	4,000	0.2	540	IP40		
EAMM-U-D32-32B	DNCE	1	2.93	3,000	0.05	300	IP40	13	
EAMM-U-D32-40A	DNCE, EGSL	1	2.93	3,000	0.05	300	IP40		
EAMM-U-D40-42B	DNCE	3	10.0	3,000	0.1	660	IP40		
EAMM-U-D40-42C	DNCE	3	10.0	3,000	0.1	690	IP40		
EAMM-U-D40-55A	DNCE, EGSL	3	10.0	3,000	0.1	530	IP40		
EAMM-U-D60-52B	DNCE	5.5	70.5	3,000	0.3	1,530	IP40		
EAMM-U-D60-52C	DNCE	5.5	70.5	3,000	0.3	1,630	IP40		
EAMM-U-D60-70A	DNCE, EGSL	5.5	70.5	3,000	0.3	1,170	IP40		
EAMM-U-E24-32B	DMES	1	3.02	3,000	0.05	240	IP40		12
EAMM-U-E24-40A	DMES	1	3.02	3,000	0.05	240	IP40		
EAMM-U-E32-42B	DGE-SP, DMES	3	10.2	3,000	0.1	660	IP40		
EAMM-U-E32-42C	DGE-SP, DMES	3	10.2	3,000	0.1	690	IP40		
EAMM-U-E32-55A	DGE-SP, DMES	3	10.2	3,000	0.1	540	IP40		
EAMM-U-E48-52B	DGE-SP, DMES	5.5	71.1	3,000	0.3	1,700	IP40		
EAMM-U-E48-52C	DGE-SP, DMES	5.5	71.1	3,000	0.3	1,800	IP40		
EAMM-U-E48-70A	DGE-SP, DMES	5.5	71.1	3,000	0.3	1,300	IP40		

1) Only in combination with attached motor and axis.

Operating and environmental conditions		
Ambient temperature	[°C]	0 ... +50
Storage temperature	[°C]	-25 ... +60
Relative air humidity	[%]	0 ... 95
Corrosion resistance class CRC ²⁾		1
Note on materials		Contains PWIS (paint-wetting impairment substances)
		RoHS-compliant

2) Corrosion resistance class 1 according to Festo standard 940 070
 Components subject to low corrosion stress. Transport and storage protection. Parts that do not have primarily decorative surface requirements, e.g. in internal areas that are not visible or behind covers.

Parallel kits EAMM-U

Technical data



Properties:

- Increased housing rigidity
- More flexible motor connection possible
- Optionally with protection to IP65
- Use in combination with third-party motors on request

Materials:

Housing: Wrought aluminium alloy
 Clamping component, clamping sleeve, toothed belt pulley: Corrosion-resistant steel
 Toothed belt: Polychloroprene
 Screws: Galvanised steel

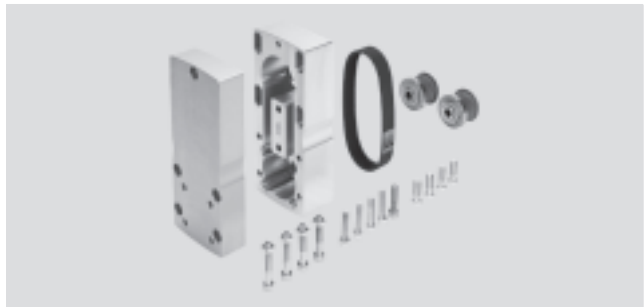

General technical data									
Type	For axis	Transferable torque [Nm]	Mass moment of inertia [kgmm ²]	Max. rotational speed [rpm]	No-load driving torque [Nm]	Weight [g]	Protection class ¹⁾	→ Page	
EAMM-U-50-D32-40A-78	DNCE, EGSL	1	12.1	6,000	0.01	600	IP40	14	
EAMM-U-50-D32-40A-78-S1	DNCE	1	12.1	6,000	0.01	620	IP65		
EAMM-U-50-D32-42A-78	DNCE, EGSL	1	12.1	6,000	0.01	610	IP40		
EAMM-U-50-D32-42A-78-S1	DNCE	1	12.1	6,000	0.01	630	IP65		
EAMM-U-50-S38-40A-78	EGC-BS	1	12.1	6,000	0.01	580	IP40	15	
EAMM-U-50-S38-42A-78	EGC-BS	1	12.1	6,000	0.01	590	IP40		
EAMM-U-60-D32-55A-91	DNCE, EGSL	3	26.7	6,000	0.07	1,050	IP40	14	
EAMM-U-60-D32-55A-91-S1	DNCE	3	26.7	6,000	0.07	1,100	IP65		
EAMM-U-60-D32-57A-91	DNCE, EGSL	3	26.7	6,000	0.07	1,160	IP40		
EAMM-U-60-D32-57A-91-S1	DNCE	3	26.7	6,000	0.07	1,190	IP65		
EAMM-U-60-D40-55A-91	DNCE, EGSL	3	26.7	6,000	0.07	1,040	IP40		
EAMM-U-60-D40-55A-91-S1	DNCE	3	26.7	6,000	0.07	1,080	IP65		
EAMM-U-60-D40-57A-91	DNCE, EGSL	3	26.7	6,000	0.07	1,140	IP40		
EAMM-U-60-D40-57A-91-S1	DNCE	3	26.7	6,000	0.07	1,170	IP65		
EAMM-U-60-S38-55A-91	EGC-BS	3	26.7	6,000	0.07	990	IP40		15
EAMM-U-60-S38-57A-91	EGC-BS	3	26.7	6,000	0.07	1,090	IP40		
EAMM-U-60-S48-55A-91	EGC-BS	3	26.7	6,000	0.07	1,060	IP40		
EAMM-U-60-S48-57A-91	EGC-BS	3	26.7	6,000	0.07	1,160	IP40		
EAMM-U-86-D40-70A-102	DNCE, EGSL	9.5	175	5,000	0.25	2,450	IP40	14	
EAMM-U-86-D40-70A-102-S1	DNCE	9.5	175	5,000	0.25	2,460	IP65		
EAMM-U-86-D40-87A-102	DNCE, EGSL	9.5	175	5,000	0.25	2,510	IP40		
EAMM-U-86-D40-87A-102-S1	DNCE	9.5	175	5,000	0.25	2,530	IP65		
EAMM-U-86-D60-70A-102	DNCE, EGSL	9.5	175	5,000	0.25	2,440	IP40		
EAMM-U-86-D60-70A-102-S1	DNCE	9.5	175	5,000	0.25	2,460	IP65		
EAMM-U-86-D60-87A-102	DNCE, EGSL	9.5	175	5,000	0.25	2,510	IP40		
EAMM-U-86-D60-87A-102-S1	DNCE	9.5	175	5,000	0.25	2,520	IP65		
EAMM-U-86-S48-70A-102	EGC-BS	9.5	175	5,000	0.25	2,440	IP40		15
EAMM-U-86-S48-87A-177	EGC-BS	9.5	175	5,000	0.25	3,270	IP40		
EAMM-U-86-S62-70A-177	EGC-BS	9.5	175	5,000	0.25	3,270	IP40		
EAMM-U-86-S62-87A-177	EGC-BS	9.5	175	5,000	0.25	3,330	IP40		

1) Only in combination with attached motor and axis.

Parallel kits EAMM-U

Technical data

General technical data								
Type	For axis	Transferable torque [Nm]	Mass moment of inertia [kgmm ²]	Max. rotational speed [rpm]	No-load driving torque [Nm]	Weight [g]	Protection class ¹⁾	→ Page
EAMM-U-110-D60-100A-120	DNCE, EGSL	25	799	5,000	0.3	4,950	IP40	14
EAMM-U-110-D60-100A-120-S1	DNCE	25	799	5,000	0.3	5,020	IP65	
EAMM-U-110-S62-100A-207	EGC-BS	25	799	5,000	0.3	6,900	IP40	15
EAMM-U-110-S95-100A-207	EGC-BS	25	799	5,000	0.3	6,810	IP40	
EAMM-U-145-S62-140A-288	EGC-BS	50	2,270	4,000	2.0	15,030	IP40	
EAMM-U-145-S95-140A-288	EGC-BS	50	2,270	4,000	2.0	14,850	IP40	

1) Only in combination with attached motor and axis

Operating and environmental conditions		
Ambient temperature	[°C]	-10 ... +60
Storage temperature	[°C]	-25 ... +60
Relative air humidity	[%]	0 ... 95
Corrosion resistance class CRC ²⁾		2
Note on materials		RoHS-compliant

2) Corrosion resistance class 2 according to Festo standard 940 070
 Components subject to moderate corrosion stress. Externally visible parts with primarily decorative surface requirements which are in direct contact with a normal industrial environment or media such as coolants or lubricating agents.

Parallel kits EAMM-U

Technical data

FESTO

Dimensions and ordering data Download CAD Data → www.festo.com/us/cad

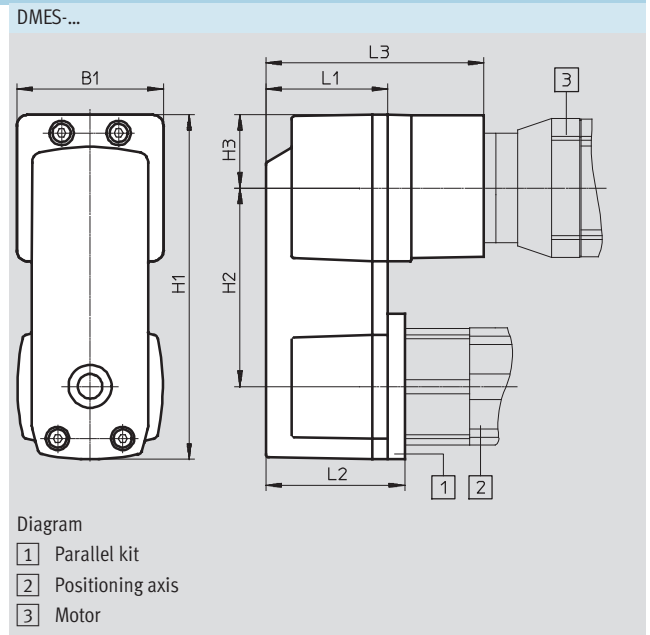
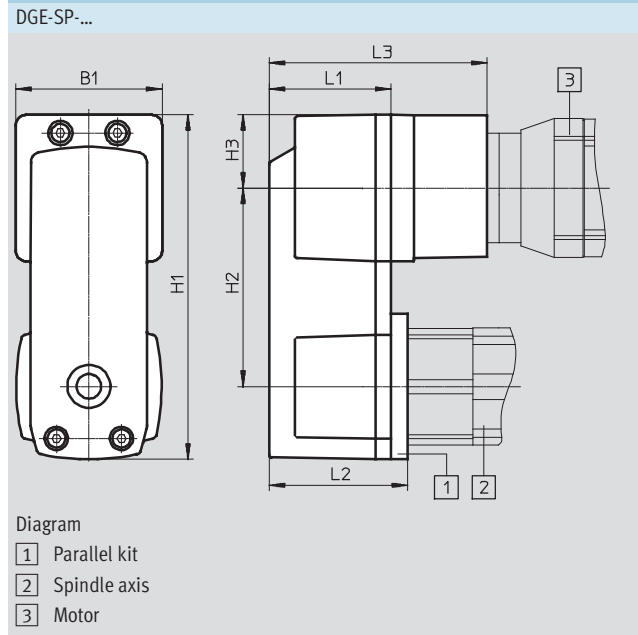

Type	B1	H1	H2	H3	L1	L2	L3	Part No.	Type
EAMM-U-E24-32B ¹⁾	43.3	110.05	69 _{-0.1}	21.7	39	-	-	543225	EAMM-U-E24-32B
EAMM-U-E24-40A ¹⁾								543226	EAMM-U-E24-40A
EAMM-U-E32-42B	56.4	132.7	76.5 _{-0.1}	28.2	47	53.5	84	543228	EAMM-U-E32-42B
EAMM-U-E32-42C							97	543229	EAMM-U-E32-42C
EAMM-U-E32-55A							-	543230	EAMM-U-E32-55A
EAMM-U-E48-52B	85.8	189.9	107.5 _{-0.2}	42.9	58	66.5	106	543232	EAMM-U-E48-52B
EAMM-U-E48-52C							120	543233	EAMM-U-E48-52C
EAMM-U-E48-70A							-	543234	EAMM-U-E48-70A

1) Only in combination with DMES-...

Parallel kits EAMM-U

Technical data

Dimensions and ordering data

Download CAD Data → www.festo.com/us/cad

EGSL-...

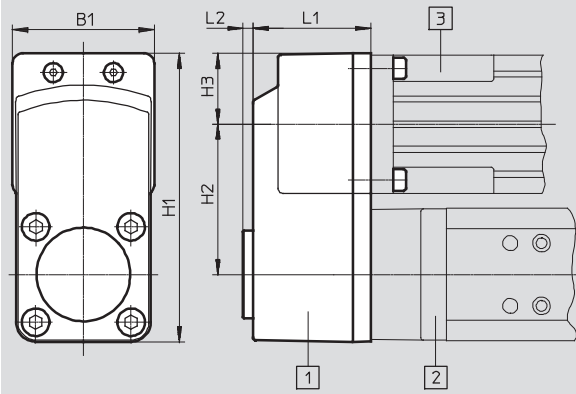

Diagram:

- 1 Parallel kit
- 2 Mini slide
- 3 Motor

Note

The motor can only be mounted on the side and underneath.

DNCE-...

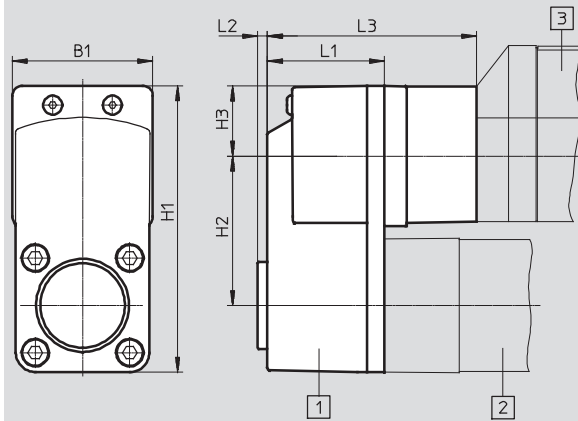

Diagram:

- 1 Parallel kit
- 2 Electric cylinder
- 3 Motor

Type	B1	H1	H2 ±0.1	H3	L1	L2	L3	Part No.	Type
EAMM-U-D32-32B ¹⁾	45.1	93.1	48	22.6	40	4	-	543152	EAMM-U-D32-32B
EAMM-U-D32-40A								543150	EAMM-U-D32-40A
EAMM-U-D40-42B ¹⁾	56.5	115	60	28.2	47	4	84	543159	EAMM-U-D40-42B
EAMM-U-D40-42C ¹⁾							97	543160	EAMM-U-D40-42C
EAMM-U-D40-55A							-	543157	EAMM-U-D40-55A
EAMM-U-D60-52B ¹⁾	86	162.6	82.5	42.9	58	4	106	543167	EAMM-U-D60-52B
EAMM-U-D60-52C ¹⁾							120	543168	EAMM-U-D60-52C
EAMM-U-D60-70A							-	543165	EAMM-U-D60-70A

1) Only in combination with DNCE-...

Parallel kits EAMM-U

Technical data

FESTO

Dimensions and ordering data Download CAD Data → www.festo.com/us/cad

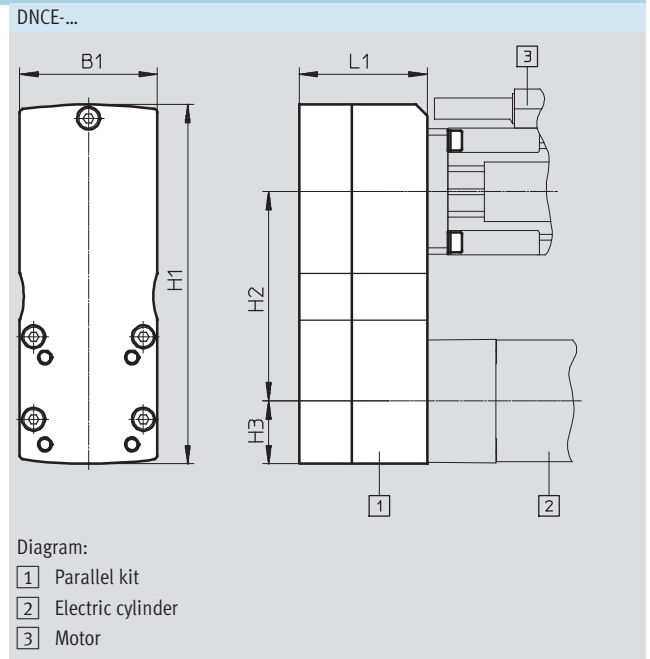
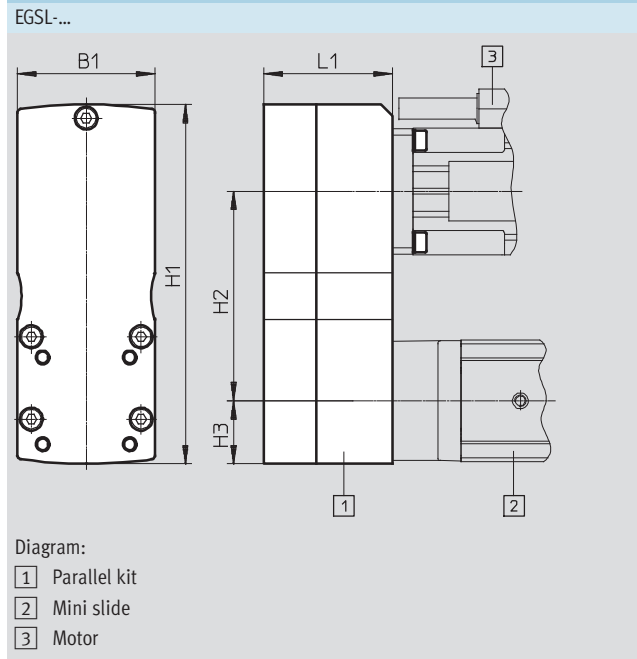

Type	B1	H1	H2 ±1	H3	L1	Part No.	Type
EAMM-U-50-D32-40A-78	50	128.8	78	22.8	45	1201591	EAMM-U-50-D32-40A-78
EAMM-U-50-D32-40A-78-S1 ¹⁾						1202302	EAMM-U-50-D32-40A-78-S1
EAMM-U-50-D32-42A-78						1201607	EAMM-U-50-D32-42A-78
EAMM-U-50-D32-42A-78-S1 ¹⁾						1202312	EAMM-U-50-D32-42A-78-S1
EAMM-U-60-D32-55A-91	60	157	91.5	27.5	56	1210126	EAMM-U-60-D32-55A-91
EAMM-U-60-D32-55A-91-S1 ¹⁾						1210450	EAMM-U-60-D32-55A-91-S1
EAMM-U-60-D32-57A-91						1210419	EAMM-U-60-D32-57A-91
EAMM-U-60-D32-57A-91-S1 ¹⁾						1210453	EAMM-U-60-D32-57A-91-S1
EAMM-U-60-D40-55A-91						1210438	EAMM-U-60-D40-55A-91
EAMM-U-60-D40-55A-91-S1 ¹⁾						1210458	EAMM-U-60-D40-55A-91-S1
EAMM-U-60-D40-57A-91						1210442	EAMM-U-60-D40-57A-91
EAMM-U-60-D40-57A-91-S1 ¹⁾						1210462	EAMM-U-60-D40-57A-91-S1
EAMM-U-86-D40-70A-102	86	188.5	102.5	38	69	1212826	EAMM-U-86-D40-70A-102
EAMM-U-86-D40-70A-102-S1 ¹⁾						1212854	EAMM-U-86-D40-70A-102-S1
EAMM-U-86-D40-87A-102						1215802	EAMM-U-86-D40-87A-102
EAMM-U-86-D40-87A-102-S1 ¹⁾						1215814	EAMM-U-86-D40-87A-102-S1
EAMM-U-86-D60-70A-102					71	1212477	EAMM-U-86-D60-70A-102
EAMM-U-86-D60-70A-102-S1 ¹⁾						1212835	EAMM-U-86-D60-70A-102-S1
EAMM-U-86-D60-87A-102						1215784	EAMM-U-86-D60-87A-102
EAMM-U-86-D60-87A-102-S1 ¹⁾						1215810	EAMM-U-86-D60-87A-102-S1
EAMM-U-110-D60-100A-120	110	225	120	45	82	1202436	EAMM-U-110-D60-100A-120
EAMM-U-110-D60-100A-120-S1 ¹⁾						1203112	EAMM-U-110-D60-100A-120-S1

1) Only in combination with DNCE-...

Parallel kits EAMM-U

Technical data

Dimensions and ordering data

Download CAD Data → www.festo.com/us/cad

EGC-...-BS-...

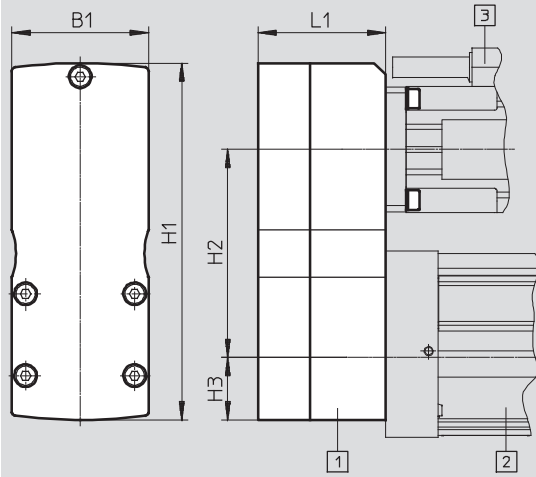

Diagram:

- 1 Parallel kit
- 2 Spindle axis
- 3 Motor

Type	B1	H1	H2 ±1	H3	L1	Part No.	Type
EAMM-U-50-S38-40A-78	50	131	78	25	43	1217708	EAMM-U-50-S38-40A-78
1217945						EAMM-U-50-S38-42A-78	
EAMM-U-60-S38-55A-91	60	157	91.5	27.5	53	1218538	EAMM-U-60-S38-55A-91
EAMM-U-60-S38-57A-91						1218568	EAMM-U-60-S38-57A-91
EAMM-U-60-S48-55A-91	60	161.5	91.5	32	54	1219370	EAMM-U-60-S48-55A-91
EAMM-U-60-S48-57A-91						1219379	EAMM-U-60-S48-57A-91
EAMM-U-86-S48-70A-102	86	188.5	102.5	38	67	1217689	EAMM-U-86-S48-70A-102
EAMM-U-86-S48-87A-177	86	268.5	177.5	43	67	1217604	EAMM-U-86-S48-87A-177
EAMM-U-86-S62-70A-177	86	268.5	177.5	43	69	1217543	EAMM-U-86-S62-70A-177
EAMM-U-86-S62-87A-177						1217373	EAMM-U-86-S62-87A-177
EAMM-U-110-S62-100A-207	110	322.5	207.5	55	82	1217381	EAMM-U-110-S62-100A-207
EAMM-U-110-S95-100A-207						1220656	EAMM-U-110-S95-100A-207
EAMM-U-145-S62-140A-288	145	448	288	70	99.5	1219440	EAMM-U-145-S62-140A-288
EAMM-U-145-S95-140A-288						1220582	EAMM-U-145-S95-140A-288

Parallel kits EAMM-U

Technical data

FESTO

Dimensions and ordering data

Download CAD Data → www.festo.com/us/cad

EGSA-...

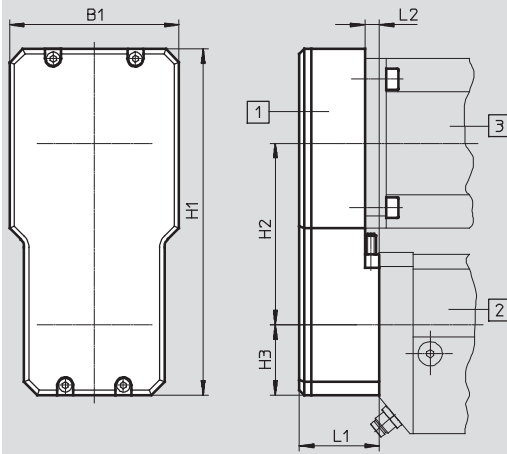

Diagram:

- 1 Parallel kit
- 2 Cantilever axis
- 3 Motor

Type	B1	H1	H2	H3 +1/-4	L1	L2	Part No.	Type
EAMM-U-A19-40A	49	107	24.5	57	30	7	559785	EAMM-U-A19-40A
EAMM-U-A22-55A	58	133	29	67.8	32	4.5	559786	EAMM-U-A22-55A
EAMM-U-A22-70A	70	143	29	75	33	6	559787	EAMM-U-A22-70A

Parallel kits EAMM-U

Accessories

Counter bearing EAMG

Material:
Wrought aluminium alloy
RoHS-compliant

Can only be used in combination with a parallel kit as per the following diagram (→ page 3 ... 7).

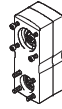

Ordering data							
Type	For size	Max. rotational speed [rpm]	Ambient temperature [°C]	Weight [g]	Part No.	Type	
EAMG-U1-50	50	6,000	-10 ... +60	20	1354281	EAMG-U1-50	
EAMG-U1-60	60	6,000		35	1354282	EAMG-U1-60	
EAMG-U1-86	86	5,000		83	1354283	EAMG-U1-86	
EAMG-U1-110	110	5,000		169	1354284	EAMG-U1-110	
EAMG-U1-145	145	4,000		186	1354285	EAMG-U1-145	

Clamping sleeve EAMH

Material:
Corrosion-resistant steel
RoHS-compliant

Can only be used in combination with a parallel kit as per the following diagram (→ page 3 ... 7).

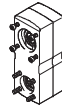

Ordering data								
Type	For size	For shaft Ø, motor/axis Ø h7 ... k7	Max. rotational speed [rpm]	Mass moment of inertia [kg mm ²]	Ambient temperature [°C]	Weight [g]	Part No.	Type
EAMH-50-5-C13.6-P	50	5	6,000	0.39	-10 ... +60	20	1354092	EAMH-50-5-C13.6-P
EAMH-50-6-C13.6-P	50	6	6,000	0.38		19	1354093	EAMH-50-6-C13.6-P
EAMH-50-8-C13.6-P	50	8	6,000	0.35		16	1354094	EAMH-50-8-C13.6-P
EAMH-60-12-C18.1-P	60	12	6,000	1.3		32	1354099	EAMH-60-12-C18.1-P
EAMH-60-6-C18.1-P	60	6	6,000	1.57		44	1354095	EAMH-60-6-C18.1-P
EAMH-60-6.35-C18.1-P	60	6.35	6,000	1.56		43	1354096	EAMH-60-6.35-C18.1-P
EAMH-60-8-C18.1-P	60	8	6,000	1.53		41	1354097	EAMH-60-8-C18.1-P
EAMH-60-9-C18.1-P	60	9	6,000	1.5		39	1354098	EAMH-60-9-C18.1-P
EAMH-86-8-C27.3-P	86	8	5,000	10.3		128	1354100	EAMH-86-8-C27.3-P
EAMH-86-11-C27.3-P	86	11	5,000	10.1		119	1354101	EAMH-86-11-C27.3-P
EAMH-86-12-C27.3-P	86	12	5,000	10		115	1354102	EAMH-86-12-C27.3-P
EAMH-86-14-C27.3-P	86	14	5,000	8.74		103	1459337	EAMH-86-14-C27.3-P
EAMH-110-12-C34-P	110	12	5,000	36.3		278	1354103	EAMH-110-12-C34-P
EAMH-110-14-C34-P	110	14	5,000	35.8		267	1354104	EAMH-110-14-C34-P
EAMH-110-16-C34-P	110	16	5,000	35.1		254	1354105	EAMH-110-16-C34-P
EAMH-110-19-C34-P	110	19	5,000	33.3		230	1354106	EAMH-110-19-C34-P
EAMH-110-25-C34-P	110	25	5,000	25.8		170	1354107	EAMH-110-25-C34-P
EAMH-145-12-C34-P	145	12	4,000	43.9		338	1354108	EAMH-145-12-C34-P
EAMH-145-19-C34-P	145	19	4,000	38		281	1459342	EAMH-145-19-C34-P
EAMH-145-24-C34-P	145	24	4,000	34		229	1354109	EAMH-145-24-C34-P
EAMH-145-25-C34-P	145	25	4,000	32.1	217	1354110	EAMH-145-25-C34-P	

Parallel kits EAMM-U

Accessories

Clamping component EADT

Material:

Plastic

RoHS-compliant

This enables high toothed belt pretension forces to be generated with low torques at the clamping component.

For adjusting the toothed belt pretension with EAMM-U-110 and EAMM-U-145.

The motor is pushed away from the axis mechanism by turning the clamping component secured in a hole in the housing (the motor can be moved in a slot for this purpose).

Can only be used in combination with a parallel kit as per the following diagram (→ page 3 ... 7).



Ordering data				
Type	Ambient temperature [°C]	Weight [g]	Part No.	Type
EADT-E-U1-110	-10 ... +60	9	1461069	EADT-E-U1-110

Product Range and Company Overview

A Complete Suite of Automation Services

Our experienced engineers provide complete support at every stage of your development process, including: conceptualization, analysis, engineering, design, assembly, documentation, validation, and production.



Custom Automation Components
Complete custom engineered solutions



Custom Control Cabinets
Comprehensive engineering support and on-site services



Complete Systems
Shipment, stocking and storage services

The Broadest Range of Automation Components

With a comprehensive line of more than 30,000 automation components, Festo is capable of solving the most complex automation requirements.



Electromechanical
Electromechanical actuators, motors, controllers & drives



Pneumatics
Pneumatic linear and rotary actuators, valves, and air supply



PLCs and I/O Devices
PLC's, operator interfaces, sensors and I/O devices

Supporting Advanced Automation... As No One Else Can!

Festo is a leading global manufacturer of pneumatic and electromechanical systems, components and controls for industrial automation, with more than 12,000 employees in 56 national headquarters serving more than 180 countries. For more than 80 years, Festo has continuously elevated the state of manufacturing with innovations and optimized motion control solutions that deliver higher performing, more profitable automated manufacturing and processing equipment. Our dedication to the advancement of automation extends beyond technology to the education and development of current and future automation and robotics designers with simulation tools, teaching programs, and on-site services.

Quality Assurance, ISO 9001 and ISO 14001 Certifications

Festo Corporation is committed to supply all Festo products and services that will meet or exceed our customers' requirements in product quality, delivery, customer service and satisfaction.

To meet this commitment, we strive to ensure a consistent, integrated, and systematic approach to management that will meet or exceed the requirements of the ISO 9001 standard for Quality Management and the ISO 14001 standard for Environmental Management.



© Copyright 2008, Festo Corporation. While every effort is made to ensure that all dimensions and specifications are correct, Festo cannot guarantee that publications are completely free of any error, in particular typing or printing errors. Accordingly, Festo cannot be held responsible for the same. For Liability and Warranty conditions, refer to our "Terms and Conditions of Sale", available from your local Festo office. All rights reserved. No part of this publication may be reproduced, distributed, or transmitted in any form or by any means, electronic, mechanical, photocopying or otherwise, without the prior written permission of Festo. All technical data subject to change according to technical update.



Printed on recycled paper at New Horizon Graphic, Inc., FSC certified as an environmentally friendly printing plant.

Festo North America

Festo Regional Contact Center

5300 Explorer Drive
Mississauga, Ontario L4W 5G4
Canada

USA Customers:

For ordering assistance,

Call: 1.800.99.FESTO (1.800.993.3786)

Fax: 1.800.96.FESTO (1.800.963.3786)

Email: customer.service@us.festo.com

For technical support,

Call: 1.866.GO.FESTO (1.866.463.3786)

Fax: 1.800.96.FESTO (1.800.963.3786)

Email: product.support@us.festo.com

Canadian Customers:

Call: 1.877.GO.FESTO (1.877.463.3786)

Fax: 1.877.FX.FESTO (1.877.393.3786)

Email: festo.canada@ca.festo.com

USA Headquarters

Festo Corporation
395 Moreland Road
P.O. Box 18023
Hauppauge, NY 11788, USA
www.festo.com/us

USA Sales Offices

Appleton

North 922 Tower View Drive, Suite N
Greenville, WI 54942, USA

Boston

120 Presidential Way, Suite 330
Woburn, MA 01801, USA

Chicago

1441 East Business Center Drive
Mt. Prospect, IL 60056, USA

Dallas

1825 Lakeway Drive, Suite 600
Lewisville, TX 75057, USA

Detroit – Automotive Engineering Center

2601 Cambridge Court, Suite 320
Auburn Hills, MI 48326, USA

New York

395 Moreland Road
Hauppauge, NY 11788, USA

Silicon Valley

4935 Southfront Road, Suite F
Livermore, CA 94550, USA

United States



USA Headquarters, East: Festo Corp., 395 Moreland Road, Hauppauge, NY 11788

Phone: 1.631.435.0800; Fax: 1.631.435.8026;

Email: info@festo-usa.com

www.festo.com/us

Canada



Headquarters: Festo Inc., 5300 Explorer Drive, Mississauga, Ontario L4W 5G4

Phone: 1.905.624.9000; Fax: 1.905.624.9001;

Email: festo.canada@ca.festo.com

www.festo.ca

Mexico



Headquarters: Festo Pneumatic, S.A., Av. Ceylán 3, Col. Tequesquahuac,
54020 Tlalneantla, Edo. de México

Phone: 011 52 [55] 53 21 66 00; Fax: 011 52 [55] 53 21 66 65;

Email: festo.mexico@mx.festo.com

www.festo.com/mx

Central USA

Festo Corporation
1441 East Business
Center Drive
Mt. Prospect, IL 60056, USA
Phone: 1.847.759.2600
Fax: 1.847.768.9480



Western USA

Festo Corporation
4935 Southfront Road,
Suite F
Livermore, CA 94550, USA
Phone: 1.925.371.1099
Fax: 1.925.245.1286



Festo Worldwide

Argentina Australia Austria Belarus Belgium Brazil Bulgaria Canada Chile China Colombia Croatia Czech Republic Denmark
Estonia Finland France Germany Great Britain Greece Hong Kong Hungary India Indonesia Iran Ireland Israel Italy Japan Latvia
Lithuania Malaysia Mexico Netherlands New Zealand Norway Peru Philippines Poland Romania Russia Serbia Singapore
Slovakia Slovenia South Africa South Korea Spain Sweden Switzerland Taiwan Thailand Turkey Ukraine United States Venezuela

www.festo.com