

Standard cylinders DNG/DNGL/DNGZK/DNGZS, ISO 15552



Standard cylinders DNG/DNGL/DNGZK/DNGZS, ISO 15552

FESTO

Features

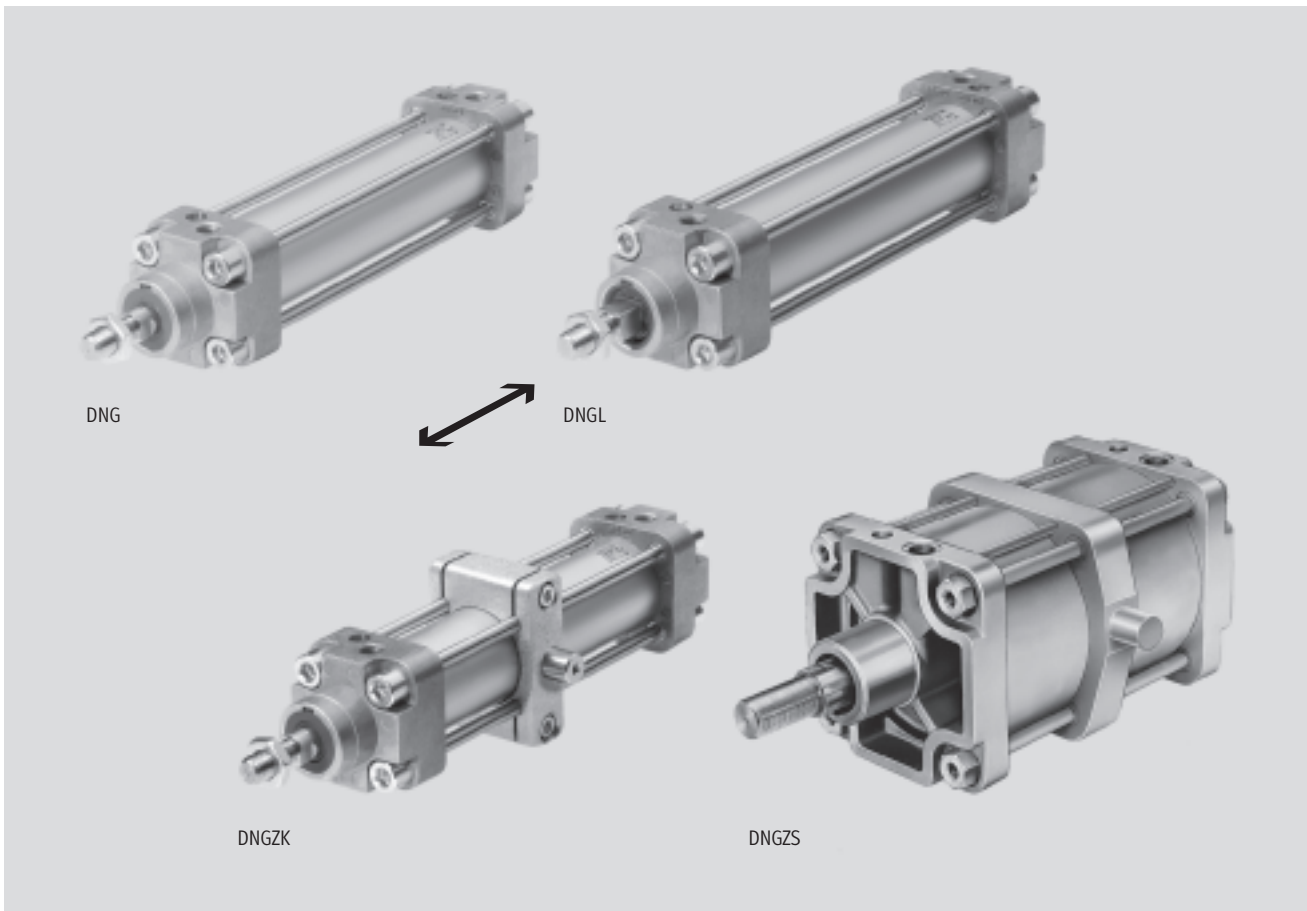

Brief description

- Double-acting
- For contactless position sensing
- With adjustable end-position cushioning at both ends
- Robust tie rod design
- DNGL/DNGLZ: secured against rotation by means of square piston rod
- Standards-based cylinders to ISO 15552 (corresponds to the withdrawn standards ISO 6431, DIN ISO 6431, VDMA 24 562, NF E 49 003.1 and UNI 10290)



DIN



Standard cylinders DNG/DNGL/DNGZK/DNGZS, ISO 15552

Features

Variants

DNG/DNGZK/DNGZS

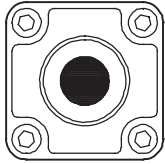

DNGL/DNGLZ with square piston rod (non-rotating)

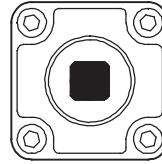

Contactless sensing with proximity sensors SMEO-1/SMT0-1/SMPO-1

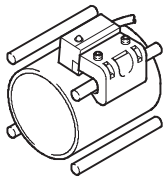

Depending on the stroke, each cylinder can have one or more proximity sensors attached to the tie rods (piston \varnothing 32 ... 100 mm). With piston \varnothing 125 ... 320 mm, they

are fixed to additional mounting rods that are included in the scope of delivery. The sensors are used for contactless sensing of end or intermediate positions of the cylinder.

Mounting options

Installation of basic version

Mounting at front

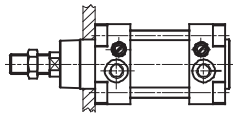

Mounting at rear

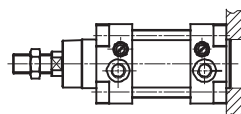

Installation options using mounting attachments

Foot mounting MS1¹⁾

HNG

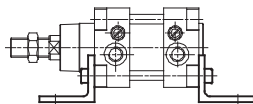

Flange mounting MF1/MF2¹⁾

FNG

at front at rear

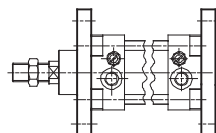

Trunnion flange

ZNG

at at rear

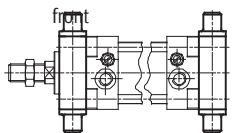

Swivel flange MP2¹⁾

SNG/SNGB/SNGL

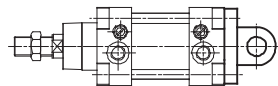

Swivel flange with spherical bearing

SSNG

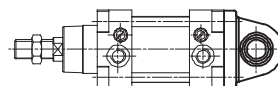

Trunnion mounting kit MT4¹⁾

LNZG

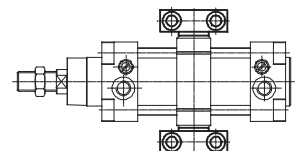

1) Standard designation to ISO 15552 (ISO 6431)

Standard cylinders DNG/DNGL/DNGZK/DNGZS, ISO 15552

Product range overview

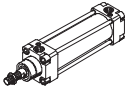
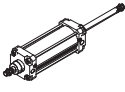
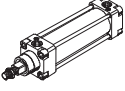
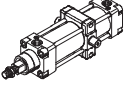
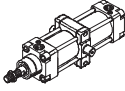
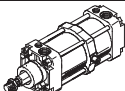
Function	Design	Type	Piston Ø [mm]	Stroke [mm]	Variable stroke ¹⁾ [mm]	Position sensing A	Cushioning Adjustable PPV				
Double-acting	Basic version										
		DNG Single-ended piston rod	32, 40, 50, 63, 80, 100, 125	25, 40, 50, 100, 125, 160, 200, 250, 320, 400, 500	1 ... 2000	■	■				
			160, 250, 320	–	1 ... 2000						
		DNG-...-S2 Through piston rod	32, 40	–	1 ... 500	■	■				
			50		1 ... 2000						
			63		1 ... 500						
			80, 100		1 ... 2000						
			125		1 ... 500						
			160, 200		1 ... 2000						
			250, 320		1 ... 2000						
			Non-rotating piston rod								
		DNGL Single-ended piston rod	32, 40, 50, 63, 80, 100	–	1 ... 500	■	■				
			32, 40, 50, 63, 80, 100	–	1 ... 2000						
		DNGLZ with central trunnion mounting	32, 40, 50, 63, 80, 100	–	1 ... 500	■	■				
			With central trunnion mounting								
			DNGZK adjustable	32, 40, 50, 63	40, 50, 80, 100, 125, 160, 200, 250, 320, 400, 500			1 ... 2000	■	■	
	80, 100	50, 80, 100, 125, 160, 200, 250, 320, 400, 500		1 ... 2000							
	125	–		1 ... 1500							
	160, 200	–		1 ... 2000							
	DNGZS fixed	250, 320	–	1 ... 1100	■	■					

1) Cylinders with position sensing require a minimum stroke of 10 mm to ensure reliable sensing

Standard cylinders DNG/DNGL/DNGZK/DNGZS, ISO 15552

Product range overview

Type	Piston rod		Heat-resistant seal S6	High corrosion protection S8	→ Page/Internet
	Male thread	Stainless steel S3			
Basic version					
DNG Single-ended piston rod	■	■	■	■	9
DNG-...-S2 Through piston rod	■	-	-	-	9
Non-rotating piston rod					
DNGL Single-ended piston rod	■	-	■	-	9
DNGL-...-S2 Through piston rod	■	-	-	-	9
DNGLZ with central trunnion mounting	■	-	■	-	9
With central trunnion mounting					
DNGZK adjustable	■	■	■	■	9
DNGZS fixed	■	■	■	■	9

Standard cylinders DNG/DNGL/DNGZK/DNGZS, ISO 15552

Peripherals overview

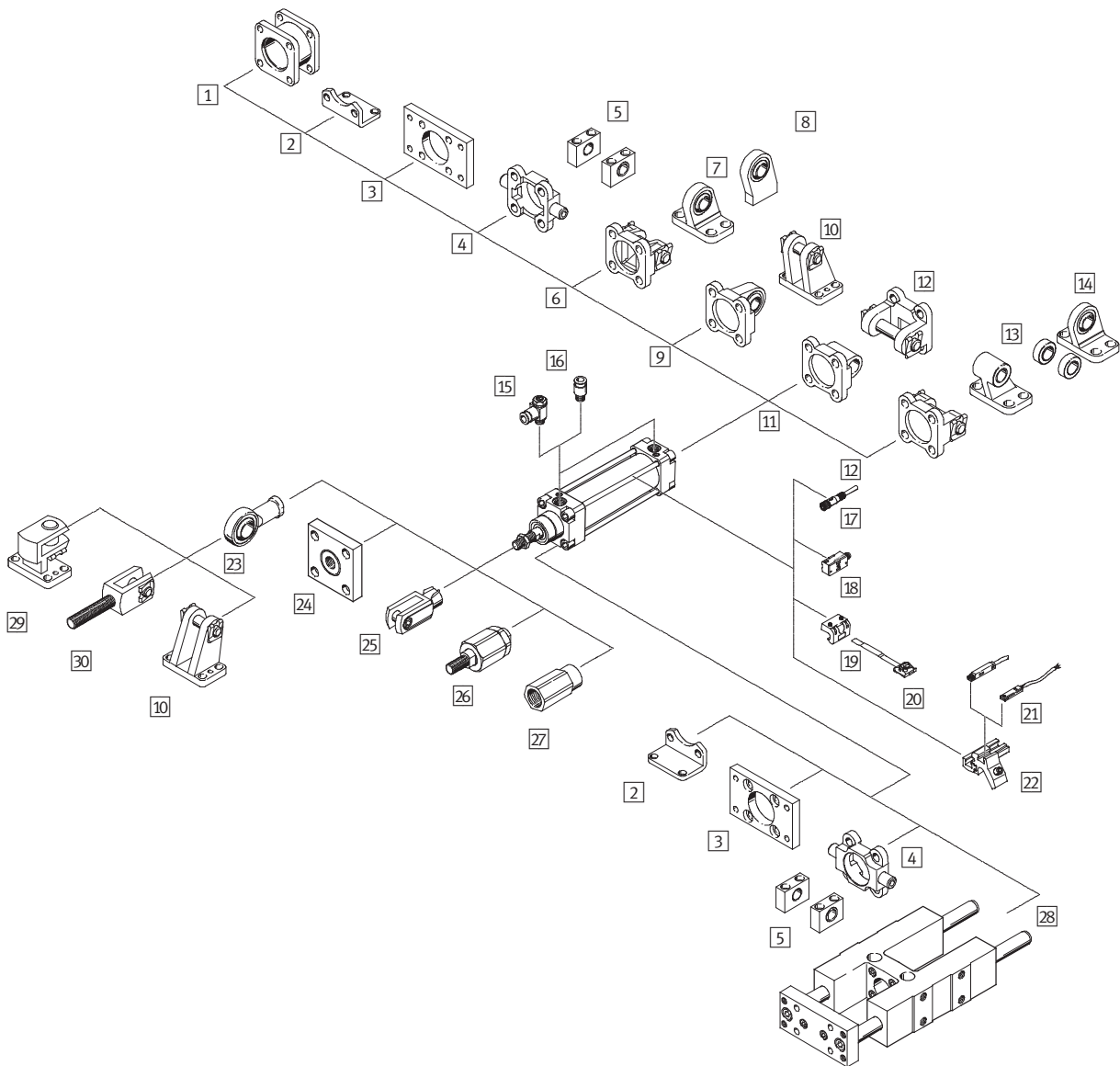

Mounting attachments and accessories		
	Brief description	→ Page/Internet
1	Adapter kit DPNG	For connecting two DNG cylinders with identical piston \varnothing to form a multi-position cylinder 19
2	Foot mounting HNG	For bearing and end caps corresponds to MS1 to ISO 15552 20
3	Flange mounting FNG	For bearing or end caps corresponds to MF1/MF2 to ISO 15552 21
4	Trunnion flange ZNG	For bearing or end caps 21
5	Trunnion support LNZG	Corresponds to MT4 to ISO 15552 22
6	Swivel flange SNG	For end caps 22

Standard cylinders DNG/DNGL/DNGZK/DNGZS, ISO 15552

Peripherals overview

Mounting attachments and accessories		
	Brief description	→ Page/Internet
7	Clevis foot mounting LSNG	With spherical bearing 25
8	Clevis foot mounting LSNSG	Weld-on with spherical bearing 25
9	Swivel flange SSNG	With spherical bearing for clevis foot mounting LBG 23
10	Clevis foot mounting LBG	With non-rotating pivot pin 25
11	Swivel flange SNGL	For end caps corresponds to MP2 to ISO 15552 24
12	Swivel flange SNGB	For end caps corresponds to MP2 to ISO 15552 23
13	Clevis foot mounting LNG	For swivel flange SNGB 25
14	Clevis foot mounting LSN	With spherical bearing 25
15	One-way flow control valve GRLA	For speed regulation 25
16	Push-in fitting QS	For connecting compressed air tubing with standard O.D. quick star
17	Connecting cable, straight NEBU	– 28
	Connecting cable, angled NEBU	– 28
18	Proximity sensors SMEO-1/SMT0-1/SMPO-1-H-B	– 29
19	Sensor mounting kit SMB	For proximity sensor SMEO-1/SMT0-1 29
20	Sensor mounting kit SMBS	For proximity sensor SMPO-1-H-B 29
	Sensor mounting kit SMBR-8-8/100-S6	Corrosion resistant, for proximity sensor SME/SMT-8 29
21	Proximity sensors SME/SMT-8	– 28
22	Sensor mounting kit SMBZ-8- ...	For proximity sensor SME/SMT-8 28
23	Rod eye SGS	With spherical bearing 26
24	Coupling piece KSG/KSZ	For compensating radial deviations 26
25	Rod clevis SG	Permits a swivelling movement of the cylinder in one plane 26
26	Self-aligning rod coupler FK	For compensating radial and angular deviations 26
27	Adapter AD	– 26
28	Guided unit FENG	To protect against torsion at high torque loads 27
29	Right-angle clevis foot LQG	With non-rotating pivot pin 25
30	Rod clevis SGA	Suitable for spherical mounting of cylinders in conjunction with rod eye SGS 26

Standard cylinders DNG/DNGL/DNGZK/DNGZS, ISO 15552

Type codes

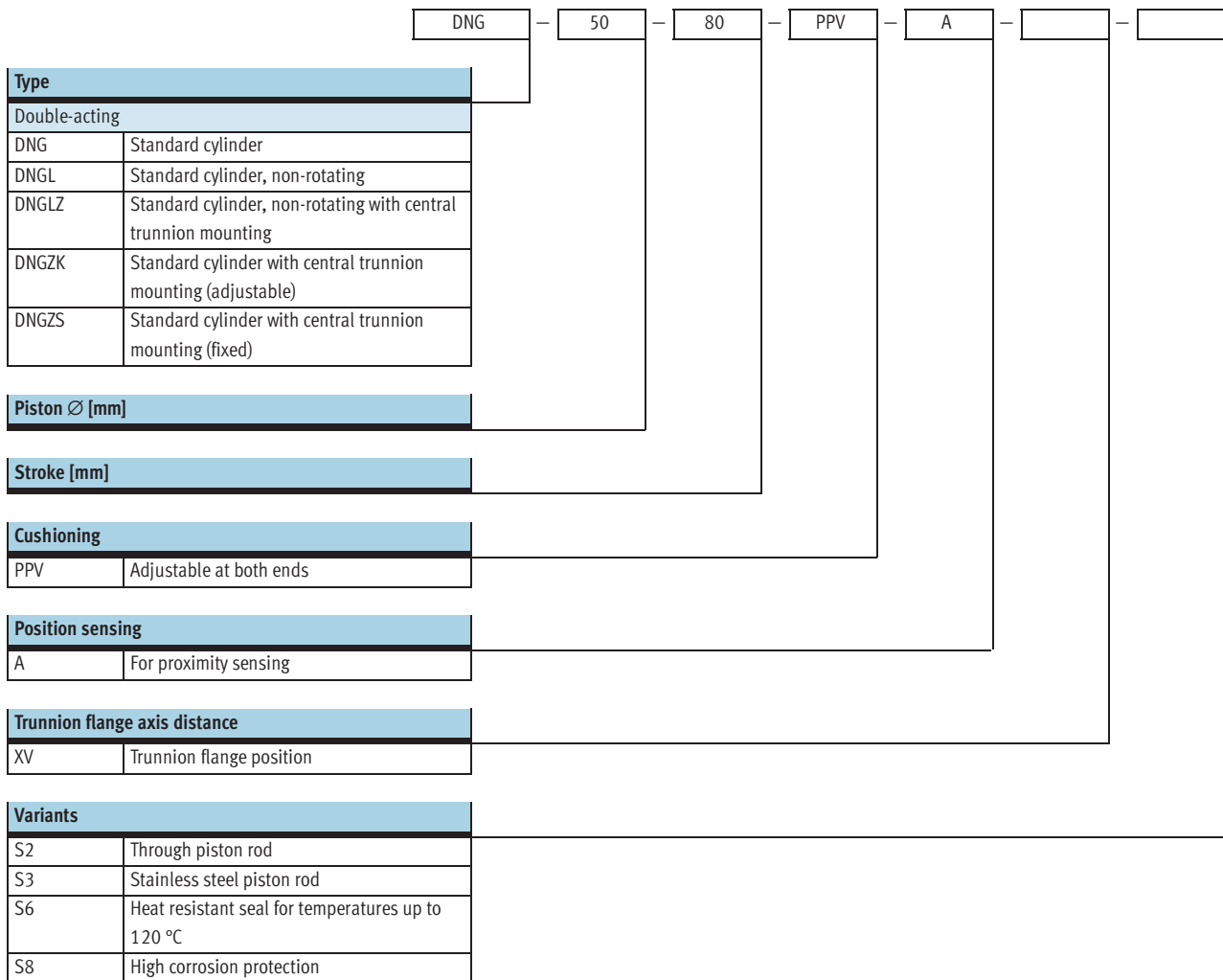

Standard cylinders DNG/DNGL/DNGZK/DNGZS, ISO 15552

Technical data

Function

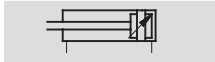

- N- Diameter
32 ... 320 mm
- T- Stroke length
10 ... 2000 mm

www.festo.com/en/
Spare_parts_service

Variants



S2



S3



S6



S8

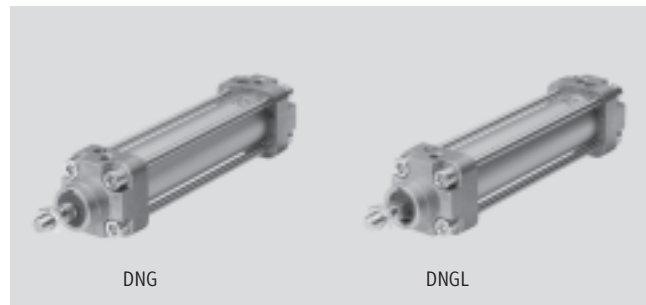

DNG

DNGL

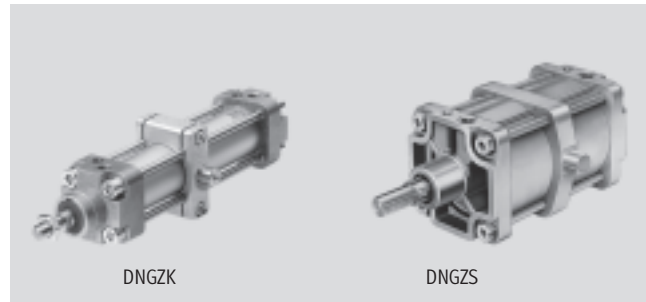

DNGZK

DNGZS

- Standards-based cylinders to ISO 15552 (corresponds to the withdrawn standards ISO 6431, DIN ISO 6431, VDMA 24 562, NF E 49 003.1 and UNI 10290)



DIN



General technical data											
Piston Ø	32	40	50	63	80	100	125	160	200	250	320
Pneumatic connection	G $\frac{1}{8}$	G $\frac{1}{4}$	G $\frac{1}{4}$	G $\frac{3}{8}$	G $\frac{3}{8}$	G $\frac{1}{2}$	G $\frac{1}{2}$	G $\frac{3}{4}$	G $\frac{3}{4}$	G1	G1
Piston rod thread	M10x1.25	M12x1.25	M16x1.5	M16x1.5	M20x1.5	M20x1.5	M27x2	M36x2	M36x2	M42x2	M48x2
Operating medium	Filtered compressed air, lubricated or unlubricated										
Design	Piston										
	Piston rod										
	Profile barrel										
Cushioning	Adjustable at both ends										
Cushioning length [mm]	19	21	23	23	30	30	40	40	50	60	66
Position sensing	For proximity sensing										
Type of mounting	Via accessories										
Mounting position	Any										

Operating and environmental conditions											
Piston Ø	32	40	50	63	80	100	125	160	200	250	320
Operating pressure [bar]	0.6 ... 10										
Ambient temperature ¹⁾ [°C]	-20 ... +80										
ATEX	Specified types → www.festo.com										

1) Note operating range of proximity sensors

Forces [N]											
Piston Ø	32	40	50	63	80	100	125	160	200	250	320
Theoretical force at 6 bar, advancing	482	753	1,178	1,870	3,015	4,712	7,360	12,064	18,850	29,450	48,250
Theoretical force at 6 bar, retracting	415	633	990	1,682	2,720	4,418	6,880	11,310	18,096	28,270	46,380

Standard cylinders DNG/DNGL/DNGZK/DNGZS, ISO 15552

Technical data

Lateral force F_Q as a function of the stroke length l

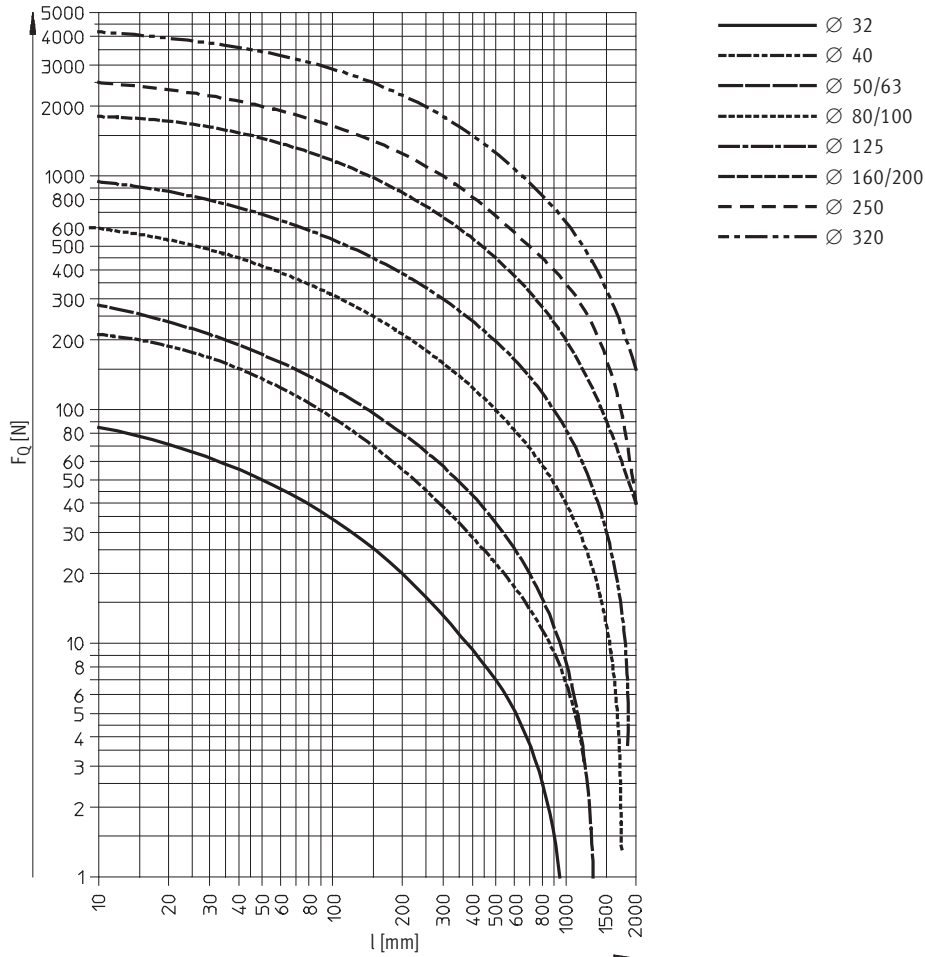
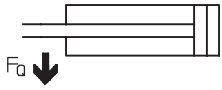

Weights [g]											
Piston Ø	32	40	50	63	80	100	125	160	200	250	320
DNG/DNGL											
Product weight at 0 mm stroke	565	790	1,400	1,725	2,875	4,100	7,305	17,265	20,115	30,800	53,200
Additional weight per 10 mm stroke	30	40	50	60	80	100	140	190	250	360	570
DNGZK/DNGLZ/DNGZS											
Product weight at 0 mm stroke	820	1,275	1,945	2,765	3,960	6,210	10,215	19,510			
Additional weight per 10 mm stroke	30	40	50	60	80	100	140	190			

Standard cylinders DNG/DNGL/DNGZK/DNGZS, ISO 15552

Technical data

Materials

Sectional view DNG/DNGL

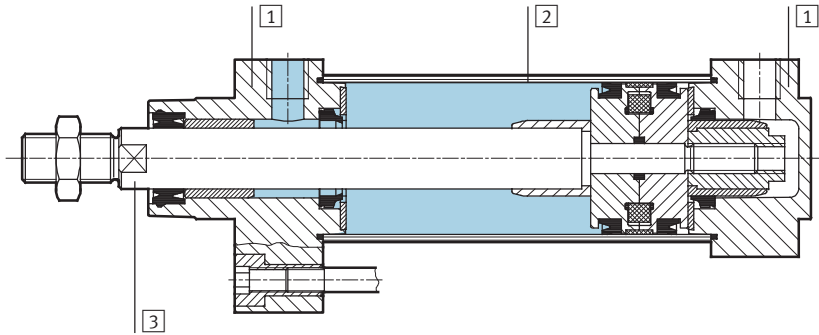

Sectional view DNGZK/DNGLZ

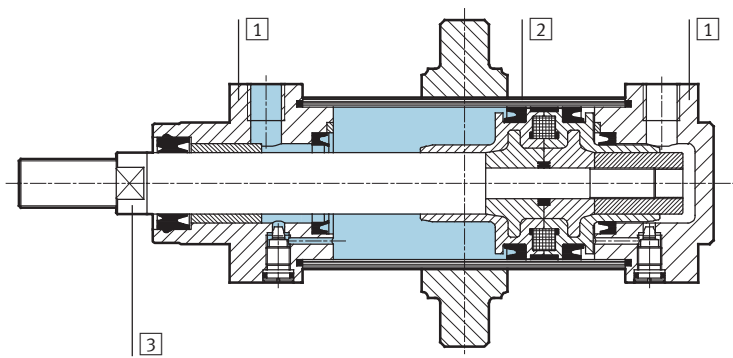

Standard cylinder	DNG/DNGL	DNGZK/DNGLZ
1 Bearing and end caps	Aluminium	Die-cast aluminium (∅ 160/200: die-cast aluminium)
2 Cylinder barrel	Aluminium	Aluminium (∅ 160/200: brass)
3 Piston rod, tie rod	High-alloy steel	
- Seals	Polyurethane, nitrile rubber	

Standard cylinders DNG/DNGL/DNGZK/DNGZS, ISO 15552

Technical data

FESTO

Dimensions

Download CAD Data → www.festo.com/us/cad

DNG/DNGL

DNG-32 ... 63

DNG-80 ... 320

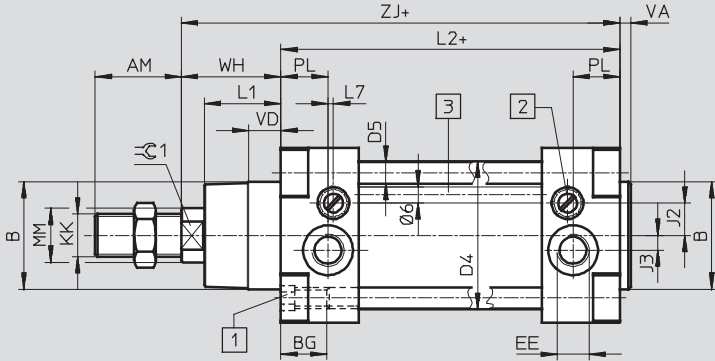
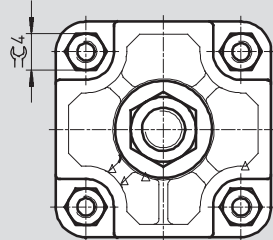
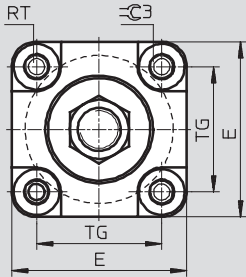

- 1 Socket head screw with female thread for mounting attachments
- 2 Regulating screw for adjustable end-position cushioning
- 3 From $\varnothing 125$ with additional rods for mounting proximity sensors

+ = plus stroke length

DNGL/DNGLZ

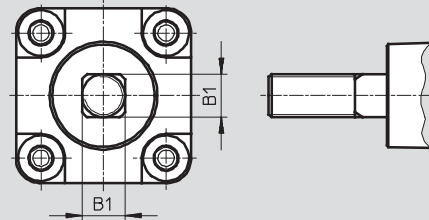

Variant S2 – Through piston rod

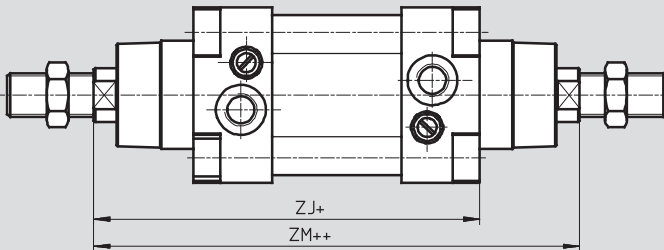

+ = plus stroke length
++ = plus 2x stroke length

DNGZK/DNGLZ/DNGZS – with central trunnion mounting adjustable, fixed

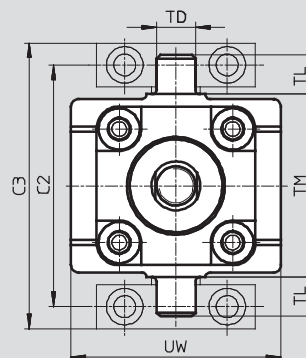
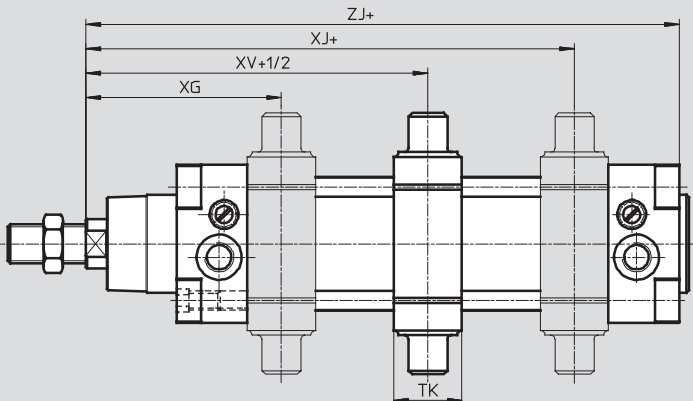

+ = plus stroke length
+1/2 = plus half stroke length

Standard cylinders DNG/DNGL/DNGZK/DNGZS, ISO 15552

FESTO

Technical data

∅ [mm]	AM	B ∅ d11	B1 f9	BG	C2	C3	D4 ∅	D5 ∅	E	EE	J2	J3
32	22	30	10	17	71	86	37	6	50	G1/8	7	-
40	24	35	12	16.5	87	105	45	6	55	G1/4	9.5	2.5
50	32	40	16	17	99	117	55	8	65	G1/4	12	5.5
63	32	45	16	19.5	116	136	68	8	75	G3/8	14	6
80	40	45	20	20	136	156	86	10	100	G3/8	15	7
100	40	55	20	20	164	189	107	10	120	G1/2	13	8
125	54	60	-	25	192	217	133	12	145	G1/2	13	8
160	72	65	-	24	245	280	167	16	186	G3/4	16	22
200	72	75	-	24	295	330	210	16	230	G3/4	22	22
250	84	90	-	25.5	375	420	254	18.3	270	G1	25	25
320	96	110	-	28.5	465	520	325	22	340	G1	30	30

∅ [mm]	KK	L1	L2	L7	MM ∅	PL	RT	TD ∅ e9	TG	TK	TL
32	M10x1.25	19	94 ±0.4	5.8	12	13	M6	12	32.5	20	12
40	M12x1.25	21.5	105 ±0.7	5.3	16	14	M6	16	38	25	16
50	M16x1.5	28.5	106 ±0.7	2	20	17.5	M8	16	46.5	28	16
63	M16x1.5	28.5	121 ±0.8	5	20	18	M8	20	56.5	30	20
80	M20x1.5	34.5	128 ±0.8	8	25	17	M10	20	72	32	20
100	M20x1.5	37.5	138 ±0.8	13	25	18	M10	25	89	38	25
125	M27x2	46	160 ±1	14	32	18	M12	25	110	44	25
160	M36x2	55	180 ±1.1	8.5	40	25.5	M16	32	140	48	32
200	M36x2	65	180 ±1.6	-	40	23	M16	32	175	48	32
250	M42x2	67	200 ±2	-	50	31	M20	40	220	60	40
320	M48x2	82	220 ±2	-	63	31	M24	50	270	70	50

∅ [mm]	TM	UW	VA	VD	WH	XG	XJ	XV	ZJ	ZM	≈C1	≈C3	≈C4
32	50	68	4	10.5	26	62 ±1.8	84 ±1.8	73 ±1.8	120	146	10	6	-
40	63	72	4	10.5	30	69 ±1.8	96 ±1.8	82.5 ±1.8	135	165	13	6	-
50	75	86	4	12	37	80 ±1.8	100 ±1.8	90 ±1.8	143	180	17	8	-
63	90	98	4	12.5	37	87 ±2.2	108 ±2.2	97.5 ±2.2	158	195	17	8	-
80	110	110	4	16.5	46	101 ±2.2	119 ±2.2	110 ±2.2	174	220	22	-	17
100	132	136	4	15.5	51	112 ±2.2	128 ±2.2	120 ±2.2	189	240	22	-	17
125	160	160	6	20.5	65	136 ±2.2	154 ±2.2	145 ±2.2	225	290	27	-	19
160	200	200	6	-	80	155 ±2.6	185 ±2.6	170 ±2.6	260	340	36	-	32
200	250	240	6	-	95	165 ±2.2	205 ±2.2	185 ±2.2	275	370	36	-	32
250	320	270	10	-	105	187	223	205	305	410	46	-	36
320	400	340	10	-	120	211	249	230	340	460	55	-	46

Note



DNGZS-250/-320-...-PPV-A:
The central trunnion mounting is fitted as standard tightly screwed with the tie rods in the cylinder mid-section. As a special design,

mounting is possible between the dimensions XG and XJ.
The required dimension XV must be entered in the order (➔ 18).

Standard cylinders DNG/DNGL/DNGZK/DNGZS, ISO 15552

FESTO

Technical data

Ordering data							
Design	Stroke [mm]	Piston Ø 32 [mm] Part No. Type ¹⁾		Piston Ø 40 [mm] Part No. Type ¹⁾		Piston Ø 50 [mm] Part No. Type ¹⁾	
Basic version							
	25	36 321	DNG-32-25-PPV-A	36 333	DNG-40-25-PPV-A	36 345	DNG-50-25-PPV-A
	40	36 322	DNG-32-40-PPV-A	36 334	DNG-40-40-PPV-A	36 346	DNG-50-40-PPV-A
	50	36 323	DNG-32-50-PPV-A	36 335	DNG-40-50-PPV-A	36 347	DNG-50-50-PPV-A
	80	36 324	DNG-32-80-PPV-A	36 336	DNG-40-80-PPV-A	36 348	DNG-50-80-PPV-A
	100	36 325	DNG-32-100-PPV-A	36 337	DNG-40-100-PPV-A	36 349	DNG-50-100-PPV-A
	125	36 326	DNG-32-125-PPV-A	36 338	DNG-40-125-PPV-A	36 350	DNG-50-125-PPV-A
	160	36 327	DNG-32-160-PPV-A	36 339	DNG-40-160-PPV-A	36 351	DNG-50-160-PPV-A
	200	36 328	DNG-32-200-PPV-A	36 340	DNG-40-200-PPV-A	36 352	DNG-50-200-PPV-A
	250	36 329	DNG-32-250-PPV-A	36 341	DNG-40-250-PPV-A	36 353	DNG-50-250-PPV-A
	320	36 330	DNG-32-320-PPV-A	36 342	DNG-40-320-PPV-A	36 354	DNG-50-320-PPV-A
	400	36 331	DNG-32-400-PPV-A	36 343	DNG-40-400-PPV-A	36 355	DNG-50-400-PPV-A
	500	36 332	DNG-32-500-PPV-A	36 344	DNG-40-500-PPV-A	36 356	DNG-50-500-PPV-A
	Variable stroke	1 ... 2,000 ²⁾	30 000	DNG-32-...-PPV-A	30 001	DNG-40-...-PPV-A	30 002
Variant S2	1 ... 2,000 ²⁾	34 625	DNG-32-...-PPV-A-S2	34 626	DNG-40-...-PPV-A-S2	34 627	DNG-50-...-PPV-A-S2
Variant S3	1 ... 2,000 ²⁾	34 973	DNG-32-...-PPV-A-S3	34 974	DNG-40-...-PPV-A-S3	34 975	DNG-50-...-PPV-A-S3
Variant S6	1 ... 2,000 ²⁾	34 854	DNG-32-...-PPV-A-S6	34 855	DNG-40-...-PPV-A-S6	34 856	DNG-50-...-PPV-A-S6
Variant S8	1 ... 2,000 ²⁾	35 453	DNG-32-...-PPV-A-S8	35 454	DNG-40-...-PPV-A-S8	35 455	DNG-50-...-PPV-A-S8
with non-rotating piston rod							
Variable stroke	1 ... 300 ²⁾	30 049	DNGL-32-...-PPV-A	–	–	–	–
	1 ... 400 ²⁾	–	–	30 050	DNGL-40-...-PPV-A	–	–
	1 ... 500 ²⁾	–	–	–	–	30 051	DNGL-50-...-PPV-A
	1 ... 600 ²⁾	–	–	–	–	–	–
Variant S2	1 ... 300 ²⁾	35 338	DNGL-32-...-PPV-A-S2	–	–	–	–
	1 ... 400 ²⁾	–	–	35 339	DNGL-40-...-PPV-A-S2	–	–
	1 ... 500 ²⁾	–	–	–	–	35 340	DNGL-50-...-PPV-A-S2
	1 ... 600 ²⁾	–	–	–	–	–	–
Variant S6	1 ... 300 ²⁾	35 344	DNGL-32-...-PPV-A-S6	–	–	–	–
	1 ... 400 ²⁾	–	–	35 345	DNGL-40-...-PPV-A-S6	–	–
	1 ... 500 ²⁾	–	–	–	–	35 346	DNGL-50-...-PPV-A-S6
	1 ... 600 ²⁾	–	–	–	–	–	–
with adjustable central trunnion mounting							
	40	36 405	DNGZK-32-40-PPV-A	36 416	DNGZK-40-40-PPV-A	36 427	DNGZK-50-40-PPV-A
	50	36 406	DNGZK-32-50-PPV-A	36 417	DNGZK-40-50-PPV-A	36 428	DNGZK-50-50-PPV-A
	80	36 407	DNGZK-32-80-PPV-A	36 418	DNGZK-40-80-PPV-A	36 429	DNGZK-50-80-PPV-A
	100	36 408	DNGZK-32-100-PPV-A	36 419	DNGZK-40-100-PPV-A	36 430	DNGZK-50-100-PPV-A
	125	36 409	DNGZK-32-125-PPV-A	36 420	DNGZK-40-125-PPV-A	36 431	DNGZK-50-125-PPV-A
	160	36 410	DNGZK-32-160-PPV-A	36 421	DNGZK-40-160-PPV-A	36 432	DNGZK-50-160-PPV-A
	200	36 411	DNGZK-32-200-PPV-A	36 422	DNGZK-40-200-PPV-A	36 433	DNGZK-50-200-PPV-A
	250	36 412	DNGZK-32-250-PPV-A	36 423	DNGZK-40-250-PPV-A	36 434	DNGZK-50-250-PPV-A
	320	36 413	DNGZK-32-320-PPV-A	36 424	DNGZK-40-320-PPV-A	36 435	DNGZK-50-320-PPV-A
	400	36 414	DNGZK-32-400-PPV-A	36 425	DNGZK-40-400-PPV-A	36 436	DNGZK-50-400-PPV-A
	500	36 415	DNGZK-32-500-PPV-A	36 426	DNGZK-40-500-PPV-A	36 437	DNGZK-50-500-PPV-A
Variable stroke	1 ... 2,000 ²⁾	34 440	DNGZK-32-...-PPV-A	34 441	DNGZK-40-...-PPV-A	34 442	DNGZK-50-...-PPV-A
Variant S3	1 ... 2,000 ²⁾	34 938	DNGZK-32-...-PPV-A-S3	34 939	DNGZK-40-...-PPV-A-S3	34 940	DNGZK-50-...-PPV-A-S3
Variant S6	1 ... 2,000 ²⁾	34 947	DNGZK-32-...-PPV-A-S6	34 948	DNGZK-40-...-PPV-A-S6	34 949	DNGZK-50-...-PPV-A-S6
Variant S8	1 ... 2,000 ²⁾	35 499	DNGZK-32-...-PPV-A-S8	35 520	DNGZK-40-...-PPV-A-S8	35 521	DNGZK-50-...-PPV-A-S8



1) The scope of delivery includes a hex nut for the piston rod thread.

2) Cylinders with position sensing require a minimum stroke of 10 mm to ensure reliable sensing

Standard cylinders DNG/DNGL/DNGZK/DNGZS, ISO 15552

FESTO

Technical data

Ordering data							
Design	Stroke [mm]	Piston Ø 63 [mm]		Piston Ø 80 [mm]		Piston Ø 100 [mm]	
		Part No.	Type ¹⁾	Part No.	Type ¹⁾	Part No.	Type ¹⁾
Basic version							
	25	36 357	DNG-63-25-PPV-A	36 369	DNG-80-25-PPV-A	36 381	DNG-100-25-PPV-A
	40	36 358	DNG-63-40-PPV-A	36 370	DNG-80-40-PPV-A	36 382	DNG-100-40-PPV-A
	50	36 359	DNG-63-50-PPV-A	36 371	DNG-80-50-PPV-A	36 383	DNG-100-50-PPV-A
	80	36 360	DNG-63-80-PPV-A	36 372	DNG-80-80-PPV-A	36 384	DNG-100-80-PPV-A
	100	36 361	DNG-63-100-PPV-A	36 373	DNG-80-100-PPV-A	36 385	DNG-100-100-PPV-A
	125	36 362	DNG-63-125-PPV-A	36 374	DNG-80-125-PPV-A	36 386	DNG-100-125-PPV-A
	160	36 363	DNG-63-160-PPV-A	36 375	DNG-80-160-PPV-A	36 387	DNG-100-160-PPV-A
	200	36 364	DNG-63-200-PPV-A	36 376	DNG-80-200-PPV-A	36 388	DNG-100-200-PPV-A
	250	36 365	DNG-63-250-PPV-A	36 377	DNG-80-250-PPV-A	36 389	DNG-100-250-PPV-A
	320	36 366	DNG-63-320-PPV-A	36 378	DNG-80-320-PPV-A	36 390	DNG-100-320-PPV-A
	400	36 367	DNG-63-400-PPV-A	36 379	DNG-80-400-PPV-A	36 391	DNG-100-400-PPV-A
	500	36 368	DNG-63-500-PPV-A	36 380	DNG-80-500-PPV-A	36 392	DNG-100-500-PPV-A
	Variable stroke	1 ... 2,000 ²⁾	30 003	DNG-63-...-PPV-A	30 004	DNG-80-...-PPV-A	30 005
Variant S2	1 ... 2,000 ²⁾	34 628	DNG-63-...-PPV-A-S2	34 629	DNG-80-...-PPV-A-S2	34 630	DNG-100-...-PPV-A-S2
Variant S3	1 ... 2,000 ²⁾	34 976	DNG-63-...-PPV-A-S3	34 977	DNG-80-...-PPV-A-S3	34 978	DNG-100-...-PPV-A-S3
Variant S6	1 ... 2,000 ²⁾	34 857	DNG-63-...-PPV-A-S6	34 858	DNG-80-...-PPV-A-S6	34 859	DNG-100-...-PPV-A-S6
Variant S8	1 ... 2,000 ²⁾	35 456	DNG-63-...-PPV-A-S8	35 457	DNG-80-...-PPV-A-S8	35 458	DNG-100-...-PPV-A-S8
with non-rotating piston rod							
Variable stroke	1 ... 300 ²⁾	–	–	–	–	–	–
	1 ... 400 ²⁾	–	–	–	–	–	–
	1 ... 500 ²⁾	30 052	DNGL-63-...-PPV-A	–	–	–	–
	1 ... 600 ²⁾	–	–	30 053	DNGL-80-...-PPV-A	30 054	DNGL-100-...-PPV-A
Variant S2	1 ... 300 ²⁾	–	–	–	–	–	–
	1 ... 400 ²⁾	–	–	–	–	–	–
	1 ... 500 ²⁾	35 341	DNGL-63-...-PPV-A-S2	–	–	–	–
	1 ... 600 ²⁾	–	–	35 342	DNGL-80-...-PPV-A-S2	35 343	DNGL-100-...-PPV-A-S2
Variant S6	1 ... 300 ²⁾	–	–	–	–	–	–
	1 ... 400 ²⁾	–	–	–	–	–	–
	1 ... 500 ²⁾	35 347	DNGL-63-...-PPV-A-S6	–	–	–	–
	1 ... 600 ²⁾	–	–	35 348	DNGL-80-...-PPV-A-S6	35 349	DNGL-100-...-PPV-A-S6
with adjustable central trunnion mounting							
	40	36 438	DNGZK-63-40-PPV-A	–	–	–	–
	50	36 439	DNGZK-63-50-PPV-A	36 449	DNGZK-80-50-PPV-A	36 459	DNGZK-100-50-PPV-A
	80	36 440	DNGZK-63-80-PPV-A	36 450	DNGZK-80-80-PPV-A	36 460	DNGZK-100-80-PPV-A
	100	36 441	DNGZK-63-100-PPV-A	36 451	DNGZK-80-100-PPV-A	36 461	DNGZK-100-100-PPV-A
	125	36 442	DNGZK-63-125-PPV-A	36 452	DNGZK-80-125-PPV-A	36 462	DNGZK-100-125-PPV-A
	160	36 443	DNGZK-63-160-PPV-A	36 453	DNGZK-80-160-PPV-A	36 463	DNGZK-100-160-PPV-A
	200	36 444	DNGZK-63-200-PPV-A	36 454	DNGZK-80-200-PPV-A	36 464	DNGZK-100-200-PPV-A
	250	36 445	DNGZK-63-250-PPV-A	36 455	DNGZK-80-250-PPV-A	36 465	DNGZK-100-250-PPV-A
	320	36 446	DNGZK-63-320-PPV-A	36 456	DNGZK-80-320-PPV-A	36 466	DNGZK-100-320-PPV-A
	400	36 447	DNGZK-63-400-PPV-A	36 457	DNGZK-80-400-PPV-A	36 467	DNGZK-100-400-PPV-A
	500	36 448	DNGZK-63-500-PPV-A	36 458	DNGZK-80-500-PPV-A	36 468	DNGZK-100-500-PPV-A
Variable stroke	1 ... 2,000 ²⁾	34 443	DNGZK-63-...-PPV-A	34 444	DNGZK-80-...-PPV-A	34 445	DNGZK-100-...-PPV-A
Variant S3	1 ... 2,000 ²⁾	34 941	DNGZK-63-...-PPV-A-S3	34 942	DNGZK-80-...-PPV-A-S3	34 943	DNGZK-100-...-PPV-A-S3
Variant S6	1 ... 2,000 ²⁾	34 950	DNGZK-63-...-PPV-A-S6	34 951	DNGZK-80-...-PPV-A-S6	34 952	DNGZK-100-...-PPV-A-S6
Variant S8	1 ... 2,000 ²⁾	35 522	DNGZK-63-...-PPV-A-S8	35 523	DNGZK-80-...-PPV-A-S8	35 524	DNGZK-100-...-PPV-A-S8

1) The scope of delivery includes a hex nut for the piston rod thread.

2) Cylinders with position sensing require a minimum stroke of 10 mm to ensure reliable sensing

Standard cylinders DNG/DNGL/DNGZK/DNGZS, ISO 15552

FESTO

Technical data

Ordering data							
Design	Stroke [mm]	Piston Ø 32 [mm] Part No. Type ¹⁾		Piston Ø 40 [mm] Part No. Type ¹⁾		Piston Ø 50 [mm] Part No. Type ¹⁾	
with non-rotating piston rod and adjustable central trunnion mounting							
Variable stroke	1 ... 300 ²⁾	35 320	DNGLZ-32-...-PPV-A	–	–	–	–
	1 ... 400 ²⁾	–	–	35 321	DNGLZ-40-...-PPV-A	–	–
	1 ... 500 ²⁾	–	–	–	–	35 322	DNGLZ-50-...-PPV-A
	1 ... 600 ²⁾	–	–	–	–	–	–
Variant S6	1 ... 300 ²⁾	35 332	DNGLZ-32-...-PPV-A-S6	–	–	–	–
	1 ... 400 ²⁾	–	–	35 333	DNGLZ-40-...-PPV-A-S6	–	–
	1 ... 500 ²⁾	–	–	–	–	35 334	DNGLZ-50-...-PPV-A-S6
	1 ... 600 ²⁾	–	–	–	–	–	–

1) The scope of delivery includes a hex nut for the piston rod thread.

2) Cylinders with position sensing require a minimum stroke of 10 mm to ensure reliable sensing

Ordering data							
Design	Stroke [mm]	Piston Ø 125 [mm] Part No. Type ¹⁾		Piston Ø 160 [mm] Part No. Type ¹⁾		Piston Ø 200 [mm] Part No. Type ¹⁾	
Basic version							
	25	36 393	DNG-125-25-PPV-A	–	–	–	–
	40	36 394	DNG-125-40-PPV-A	–	–	–	–
	50	36 395	DNG-125-50-PPV-A	–	–	–	–
	80	36 396	DNG-125-80-PPV-A	–	–	–	–
	100	36 397	DNG-125-100-PPV-A	–	–	–	–
	125	36 398	DNG-125-125-PPV-A	–	–	–	–
	160	36 399	DNG-125-160-PPV-A	–	–	–	–
	200	36 400	DNG-125-200-PPV-A	–	–	–	–
	250	36 401	DNG-125-250-PPV-A	–	–	–	–
	320	36 402	DNG-125-320-PPV-A	–	–	–	–
	400	36 403	DNG-125-400-PPV-A	–	–	–	–
	500	36 404	DNG-125-500-PPV-A	–	–	–	–
Variable stroke	1 ... 2,000 ²⁾	30 006	DNG-125-...-PPV-A	33 024	DNG-160-...-PPV-A	33 025	DNG-200-...-PPV-A
	1 ... 1,100 ²⁾	–	–	–	–	–	–
Variant S2	1 ... 2,000 ²⁾	34 631	DNG-125-...-PPV-A-S2	34 632	DNG-160-...-PPV-A-S2	34 633	DNG-200-...-PPV-A-S2
	1 ... 1,100 ²⁾	–	–	–	–	–	–
Variant S3	1 ... 2,000 ²⁾	34 979	DNG-125-...-PPV-A-S3	34 980	DNG-160-...-PPV-A-S3	34 981	DNG-200-...-PPV-A-S3
	1 ... 1,100 ²⁾	–	–	–	–	–	–
Variant S6	1 ... 2,000 ²⁾	34 860	DNG-125-...-PPV-A-S6	34 861	DNG-160-...-PPV-A-S6	34 862	DNG-200-...-PPV-A-S6
	1 ... 1,100 ²⁾	–	–	–	–	–	–
Variant S8	1 ... 2,000 ²⁾	35 459	DNG-125-...-PPV-A-S8	35 497	DNG-160-...-PPV-A-S8	35 498	DNG-200-...-PPV-A-S8
	1 ... 1,100 ²⁾	–	–	–	–	–	–
with adjustable central trunnion mounting							
Variable stroke	1 ... 2,000 ²⁾	34 446	DNGZK-125-...-PPV-A	34 447	DNGZK-160-...-PPV-A	34 456	DNGZK-200-...-PPV-A
Variant S3	1 ... 2,000 ²⁾	34 944	DNGZK-125-...-PPV-A-S3	34 945	DNGZK-160-...-PPV-A-S3	34 946	DNGZK-200-...-PPV-A-S3
Variant S6	1 ... 2,000 ²⁾	34 953	DNGZK-125-...-PPV-A-S6	34 954	DNGZK-160-...-PPV-A-S6	34 955	DNGZK-200-...-PPV-A-S6
Variant S8	1 ... 2,000 ²⁾	35 525	DNGZK-125-...-PPV-A-S8	35 526	DNGZK-160-...-PPV-A-S8	35 527	DNGZK-200-...-PPV-A-S8

1) The scope of delivery includes a hex nut for the piston rod thread.

2) Cylinders with position sensing require a minimum stroke of 10 mm to ensure reliable sensing

Standard cylinders DNG/DNGL/DNGZK/DNGZS, ISO 15552

Technical data

Ordering data							
Design	Stroke [mm]	Piston Ø 63 [mm]		Piston Ø 80 [mm]		Piston Ø 100 [mm]	
		Part No.	Type ¹⁾	Part No.	Type ¹⁾	Part No.	Type ¹⁾
with non-rotating piston rod and adjustable central trunnion mounting							
Variable stroke	1 ... 300 ²⁾	-		-		-	
	1 ... 400 ²⁾	-		-		-	
	1 ... 500 ²⁾	35 323	DNGLZ-63-...-PPV-A	-		-	
	1 ... 600 ²⁾	-	-	35 324	DNGLZ-80-...-PPV-A	35 325	DNGLZ-100-...-PPV-A
Variant S6	1 ... 300 ²⁾	-		-		-	
	1 ... 400 ²⁾	-		-		-	
	1 ... 500 ²⁾	35 335	DNGLZ-63-...-PPV-A-S6	-		-	
	1 ... 600 ²⁾	-	-	35 336	DNGLZ-80-...-PPV-A-S6	35 337	DNGLZ-100-...-PPV-A-S6

- 1) The scope of delivery includes a hex nut for the piston rod thread.
- 2) Cylinders with position sensing require a minimum stroke of 10 mm to ensure reliable sensing

Ordering data					
Design	Stroke [mm]	Piston Ø 250 [mm]		Piston Ø 320 [mm]	
		Part No.	Type ¹⁾	Part No.	Type ¹⁾
Basic version					
	25	-		-	
	40	-		-	
	50	-		-	
	80	-		-	
	100	-		-	
	125	-		-	
	160	-		-	
	200	-		-	
	250	-		-	
	320	-		-	
	400	-		-	
	500	-		-	
	Variable stroke	1 ... 2,000 ²⁾	-		-
1 ... 1,100 ²⁾		151 892	DNG-250-...-PPV-A	151 897	DNG-320-...-PPV-A
Variant S2	1 ... 2,000 ²⁾	-		-	
	1 ... 1,100 ²⁾	151 893	DNG-250-...-PPV-A-S2	151 898	DNG-320-...-PPV-A-S2
Variant S3	1 ... 2,000 ²⁾	-		-	
	1 ... 1,100 ²⁾	151 894	DNG-250-...-PPV-A-S3	151 899	DNG-320-...-PPV-A-S3
Variant S6	1 ... 2,000 ²⁾	-		-	
	1 ... 1,100 ²⁾	151 895	DNG-250-...-PPV-A-S6	151 900	DNG-320-...-PPV-A-S6
Variant S8	1 ... 2,000 ²⁾	-		-	
	1 ... 1,100 ²⁾	151 896	DNG-250-...-PPV-A-S8	151 901	DNG-320-...-PPV-A-S8
with fixed central trunnion mounting					
Variable stroke	1 ... 1,100 ²⁾	→ 18			

- 1) The scope of delivery includes a hex nut for the piston rod thread.
- 2) Cylinders with position sensing require a minimum stroke of 10 mm to ensure reliable sensing

Standard cylinders DNG/DNGL/DNGZK/DNGZS, to ISO 15552



Ordering data – Modular product DNGZS

M Mandatory data						O Options		
Module No.	Function	Piston Ø	Stroke	Cushioning	Position sensing	Trunnion flange position	Temperature-resistant	Corrosion protection
157 500 157 504	DNGZS	250 320	10 ... 1 100	PPV	A	...XV	S6	S3 S8
Ordering example								
157 504	DNGZS	- 320	- 600	- PPV	- A	- 215XV	- S6	- S3

Ordering table						
Size	250	320	Condition s	Code	Enter code	
M Module No.	157 500	157 504				
Function	Standard cylinder, double-acting, with central trunnion mounting to ISO 15552				DNGZS	DNGZS
Piston Ø [mm]	250	320			-...	
Stroke [mm]	10 ... 1 100				-...	
Cushioning	Pneumatic cushioning adjustable at both ends				-PPV	-PPV
Position sensing	For proximity sensing				-A	-A
O Trunnion flange position [mm]	187 ... 1 323	211 ... 1 349	[1]		-...XV	
Temperature-resistant	Heat-resistant seals up to max. 120 °C				-S6	
Corrosion protection	Stainless steel piston rod				- S3	
	High corrosion protection including piston rod, stainless steel			[2]	-S8	

[1] ...XV Trunnion flange at standard mid-position of cylinder:
Piston Ø 250 mm: $205 \text{ mm} + \frac{\text{Stroke}}{2}$
Piston Ø 320 mm: $230 \text{ mm} + \frac{\text{Stroke}}{2}$

[2] S8 Not with S6.

Transfer order code

	DNGZS	-		-		-	PPV	-	A	-		-		-	
--	--------------	---	--	---	--	---	------------	---	----------	---	--	---	--	---	--

Standard cylinders DNG/DNGL/DNGZK/DNGZS, ISO 15552



Accessories

Adapter kit DPNG
for piston \varnothing 32 ... 100 mm

Material:
Flange: Wrought aluminium alloy;
Threaded studs, hex nuts:
Galvanised steel
Free of copper, PTFE and silicone

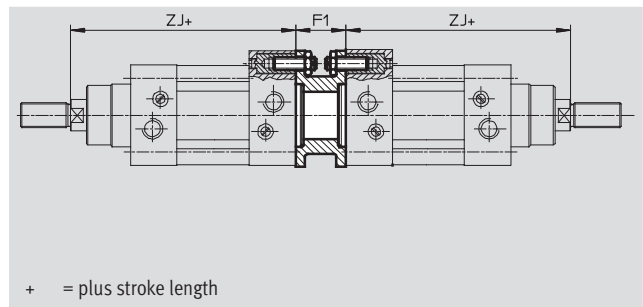

Dimensions and ordering data						
For \varnothing	F1	ZJ	Max. overall stroke length [mm]	CRC ¹⁾	Weight [g]	Part No. Type
32	27	120	1,000	2	85	159 485 DPNG-32
40	27	135	1,000	2	115	159 486 DPNG-40
50	32	143	1,000	2	210	159 487 DPNG-50
63	28	158	1,000	2	360	159 488 DPNG-63
80	38	174	1,000	2	620	159 489 DPNG-80
100	38	189	1,000	2	1,190	159 490 DPNG-100

Note
The maximum overall stroke length may not be exceeded when combining cylinders and the adapter kit.

1) Corrosion resistance class 2 according to Festo standard 940 070
Components requiring moderate corrosion resistance. Externally visible parts with primarily decorative surface requirements which are in direct contact with a surrounding industrial atmosphere or media such as cooling or lubricating agents

Connecting two cylinders with identical piston \varnothing as a 3 or 4-position cylinder

A 3 or 4-position cylinder consists of two separate cylinders whose piston rods advance in opposing directions. This means that depending upon actuation and stroke pattern, this type

of cylinder can assume up to four positions. In each case the cylinder is driven precisely against a stop. Note that when one end of the piston rod is

fixed, the cylinder barrel executes the movement. The cylinder must be connected with flexible line connections.

To achieve 3 positions

Two cylinders with identical stroke length must be connected together.

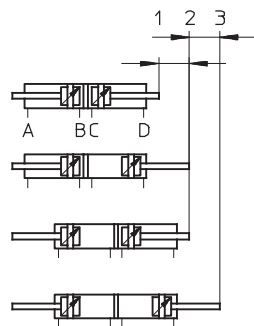

To achieve 4 positions

Two cylinders with different stroke lengths must be connected together.

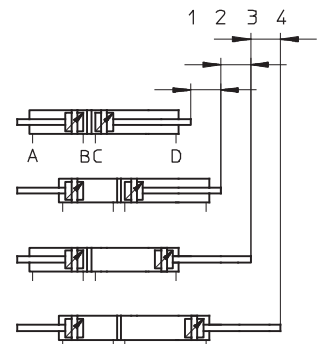

Standard cylinders DNG/DNGL/DNGZK/DNGZS, ISO 15552



Accessories

Foot mounting HNG

Material:

Galvanised steel

Free of copper, PTFE and silicone



For piston $\varnothing 32 \dots 250$

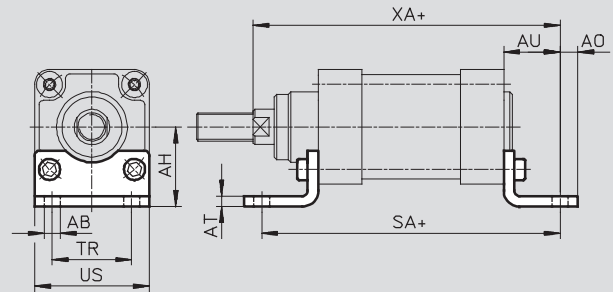

For piston $\varnothing 320$

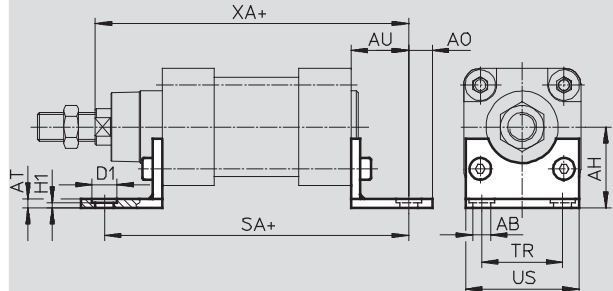

+ = plus stroke length

Dimensions and ordering data

For \varnothing [mm]	AB \varnothing H14	AH	AO	AT	AU	D1	H1	SA	TR	US	XA	CRC ¹⁾	Weight [g]	Part No.	Type
32	7	32	6.5	4	24	-	-	142	32	45	144	2	225	32 947	HNG-32
40	10	36	9	4	28	-	-	161	36	54	163	2	270	32 948	HNG-40
50	10	45	9.5	5	32	-	-	170	45	64	175	2	400	32 949	HNG-50
63	10	50	12.5	5	32	-	-	185	50	75	190	2	480	32 950	HNG-63
80	12	63	15	6	41	-	-	210	63	93	215	2	1,080	32 951	HNG-80
100	14.5	71	17.5	6	41	-	-	220	75	110	230	2	1,250	32 952	HNG-100
125	16.5	90	22	8	45	-	-	250	90	131	270	2	2,025	32 953	HNG-125
160	18.5	115	20	10	60	-	-	300	115	169	320	2	2,200	34 476	HNG-160
200	24	135	30	12	70	-	-	320	135	214	345	2	3,795	34 477	HNG-200
250	28	165	35	20	75	-	-	350	165	270	380	2	8,000	157 510	HNG-250
320	35	185	40	25	85	60	23	390	200	340	425	2	13,000	157 511	HNG-320

1) Corrosion resistance class 2 according to Festo standard 940 070

Components requiring moderate corrosion resistance. Externally visible parts with primarily decorative surface requirements which are in direct contact with a surrounding industrial atmosphere or media such as cooling or lubricating agents

Standard cylinders DNG/DNGL/DNGZK/DNGZS, ISO 15552

Accessories

Flange mounting FNG

Material:

- FNG-32 ... 100: Galvanised steel
- FNG-125 ... 320: Painted nodular graphite cast iron
- Free of copper, PTFE and silicone

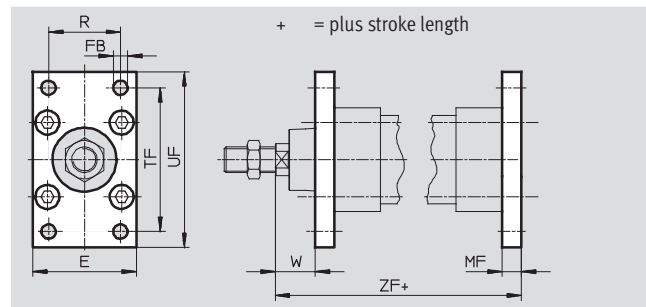
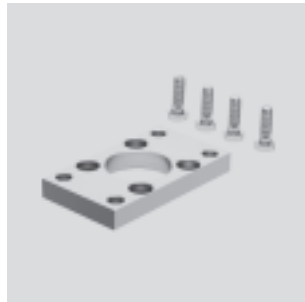

Dimensions and ordering data												
For Ø	E	FB	MF	R	TF	UF	W	ZF	CRC ¹⁾	Weight	Part No.	Type
[mm]		Ø								[g]		
32	45	7	10	32	64	80	16	130	1	221	32 940	FNG-32
40	54	9	10	36	72	90	20	145	1	291	32 941	FNG-40
50	65	9	12	45	90	110	25	155	1	536	32 942	FNG-50
63	75	9	12	50	100	120	25	170	1	679	32 943	FNG-63
80	93	12	16	63	126	150	30	190	1	1,495	32 944	FNG-80
100	110	14	16	75	150	175	35	205	1	2,041	32 945	FNG-100
125	140	16	20	90	180	220	45	245	1	2,216	32 946	FNG-125
160	180	18	20	115	230	280	60	280	1	3,550	34 478	FNG-160
200	220	22	25	135	270	320	70	300	1	5,321	34 479	FNG-200
250	270	26	25	165	330	390	80	330	1	8,657	157 508	FNG-250
320	340	33	30	200	400	470	90	370	1	15,109	157 509	FNG-320

1) Corrosion resistance class 1 according to Festo standard 940 070
Components with light corrosion exposure. Protection for transport and storage. Components without significant decorative function or surface, e.g. installed out of sight internally or behind covers.

Trunnion flange ZNG

for trunnion mounting LNZG

Material:

- Corrosion resistant cast steel
- Free of copper, PTFE and silicone

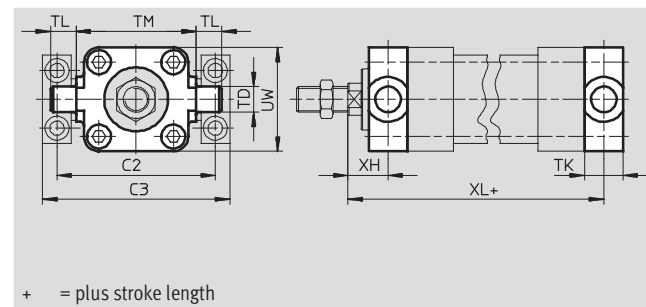

Dimensions and ordering data													
For Ø	C2	C3	TD	TK	TL	TM	UW	XH	XL	CRC ¹⁾	Weight	Part No.	Type
[mm]			Ø								[g]		
32	71	86	12	16	12	50	50	18	128	2	190	31 754	ZNG-32
40	87	105	16	20	16	63	55	20	145	2	330	31 755	ZNG-40
50	99	117	16	24	16	75	65	25	155	2	535	31 756	ZNG-50
63	116	136	20	24	20	90	75	25	170	2	800	31 757	ZNG-63
80	136	156	20	28	20	110	100	32	188	2	1,380	31 758	ZNG-80
100	164	189	25	38	25	132	120	32	208	2	2,745	31 759	ZNG-100
125	192	217	25	50	25	160	150	40	250	2	5,100	31 760	ZNG-125

1) Corrosion resistance class 2 according to Festo standard 940 070
Components requiring moderate corrosion resistance. Externally visible parts with primarily decorative surface requirements which are in direct contact with a surrounding industrial atmosphere or media such as cooling or lubricating agents

Standard cylinders DNG/DNGL/DNGZK/DNGZS, ISO 15552

FESTO

Accessories

LNZG trunnion support

Material:

Trunnion support:

32 ... 125: Anodised aluminium

160 ... 320: Galvanised steel

Plain bearing:

32 ... 200: Plastic

250 ... 320: Sintered bronze

Free of copper, PTFE and silicone

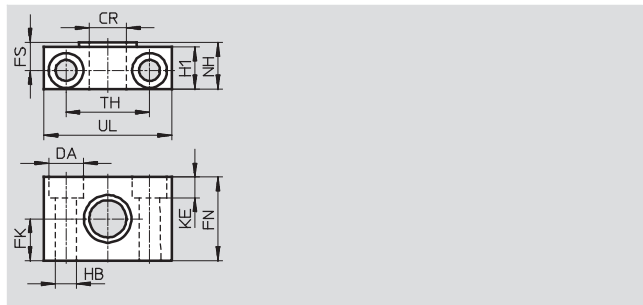
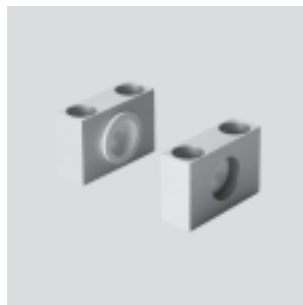

Dimensions and ordering data															
For Ø	CR	DA	FK	FN	FS	H1	HB	KE	NH	TH	UL	CRC ¹⁾	Weight	Part No.	Type
[mm]	Ø	Ø H13	Ø				Ø H13						[g]		
32	12 D11	11	15 ±0.1	30	10.5	15	6.6	6.8	18	32 ±0.2	46	2	90	32 959	LNZG-32
40/50	16 D11	15	18 ±0.1	36	12	18	9	9	21	36 ±0.2	55	2	140	32 960	LNZG-40/50
63/80	20 D11	18	20 ±0.1	40	13	20	11	11	23	42 ±0.2	65	2	190	32 961	LNZG-63/80
100/125	25 D11	20	25 ±0.1	50	16	24.5	14	13	28.5	50 ±0.2	75	2	320	32 962	LNZG-100/125
160/200	32 D11	26	30 ±0.2	60	22.5	36	18	17	40	60 ±0.3	92	2	1,830	35 780	LNZG-160/200
250	40 G7	33	35 ±0.2	70	27.5	45	22	21.5	50	90 ±0.3	140	2	1,910	157 516	LNZG-250
320	50 G7	40	40 ±0.2	80	32.5	55	26	21.5	60	100 ±0.3	150	2	6,630	157 517	LNZG-320

1) Corrosion resistance class 2 according to Festo standard 940 070

Components requiring moderate corrosion resistance. Externally visible parts with primarily decorative surface requirements which are in direct contact with a surrounding industrial atmosphere or media such as cooling or lubricating agents

Swivel flange SNG

for clevis foot LSNG/LSNSG

Material:

Die-cast aluminium

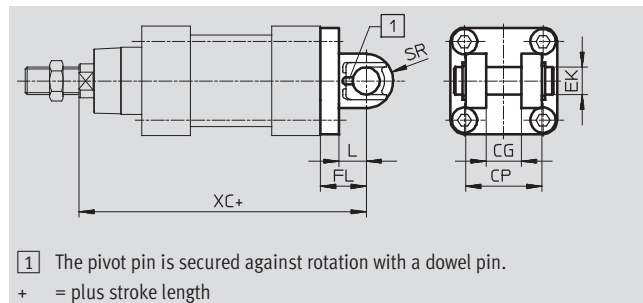

Dimensions and ordering data											
For Ø	CG	CP	EK	FL	L	SR	XC	CRC ¹⁾	Weight	Part No.	Type
[mm]	H14	d12	Ø						[g]		
32	14	34	10	22	13	11	142	2	190	32 968	SNG-32
40	16	40	12	25	16	13	160	2	270	32 969	SNG-40
50	21	45	16	27	16	15	170	2	445	32 970	SNG-50
63	21	51	16	32	21	18	190	2	675	32 971	SNG-63
80	25	65	20	36	22	20	210	2	1,265	32 972	SNG-80
100	25	75	20	41	27	22	230	2	1,790	32 973	SNG-100
125	37	97	30	50	30	26	275	2	4,000	32 974	SNG-125
160	43	122	35	55	35	32	315	2	6,558	152 597	SNG-160
200	43	122	35	60	35	32	335	2	9,678	152 598	SNG-200

1) Corrosion resistance class 2 according to Festo standard 940 070

Components requiring moderate corrosion resistance. Externally visible parts with primarily decorative surface requirements which are in direct contact with a surrounding industrial atmosphere or media such as cooling or lubricating agents

Standard cylinders DNG/DNGL/DNGZK/DNGZS, ISO 15552

FESTO

Accessories

Swivel flange SNGB for clevis foot LN/LSN

Material:
Die-cast aluminium
Ø 200: Steel

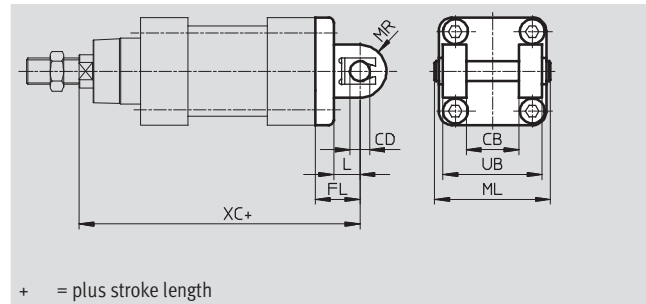

+ = plus stroke length

Dimensions and ordering data

For Ø [mm]	CB Ø	CD Ø	FL	L	ML	MR	UB h14	XC	CRC ¹⁾	Weight [g]	Part No.	Type
32	26	10	22	13	55	10	45	142	2	125	34 540	SNGB-32
40	28	12	25	16	63	12	52	160	2	175	34 541	SNGB-40
50	32	12	27	16	71	12	60	170	2	243	34 542	SNGB-50
63	40	16	32	21	83	16	70	190	2	380	34 543	SNGB-63
80	50	16	36	22	103	16	90	210	2	610	34 544	SNGB-80
100	60	20	41	27	127	20	110	230	2	1,040	34 545	SNGB-100
125	70	25	50	30	148	25	130	275	2	1,750	34 546	SNGB-125
160	90	30	55	37	191	30	170	315	2	7,000	34 547	SNGB-160
200	90	30	60	35	191	36	170	335	2	11 000	562 455	SNGB-200-B
250	110	40	70	47	231	40	200	375	2	15 200	157 512	SNGB-250
320	120	45	80	52	253	45	220	420	2	26 450	157 513	SNGB-320

1) Corrosion resistance class 2 according to Festo standard 940 070

Components requiring moderate corrosion resistance. Externally visible parts with primarily decorative surface requirements which are in direct contact with a surrounding industrial atmosphere or media such as cooling or lubricating agents

Swivel flange SSNG with spherical bearing for clevis foot LBG

Material:
Nodular graphite cast iron

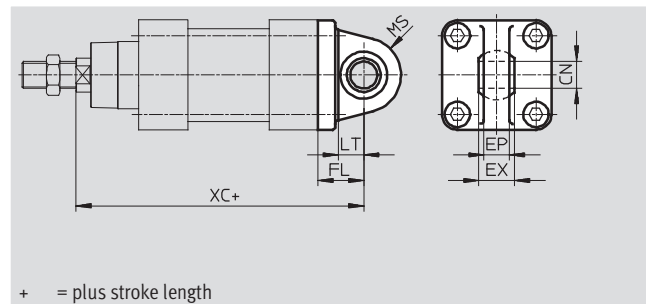

+ = plus stroke length

Dimensions and ordering data

For Ø [mm]	CN Ø	EP	EX	FL	LT	MS	XC	CRC ¹⁾	Weight [g]	Part No.	Type
32	10	10.5	14	22	–	16	142	2	195	34 291	SSNG-32
40	12	12	16	25	–	18	160	2	255	34 292	SSNG-40
50	16	15	21	27	–	21	170	2	430	34 293	SSNG-50
63	16	15	21	32	19	23	190	2	565	34 294	SSNG-63
80	20	18	25	36	21	27	210	2	940	34 295	SSNG-80
100	20	18	25	41	24	30	230	2	1,510	34 296	SSNG-100
125	30	25	37	50	28	40	275	2	3,082	34 568	SSNG-125

1) Corrosion resistance class 2 according to Festo standard 940 070

Components requiring moderate corrosion resistance. Externally visible parts with primarily decorative surface requirements which are in direct contact with a surrounding industrial atmosphere or media such as cooling or lubricating agents

Standard cylinders DNG/DNGL/DNGZK/DNGZS, ISO 15552



Accessories

Swivel flange SNGL

Material:
Die-cast aluminium

Variant CT:
Free of copper, PTFE and silicone

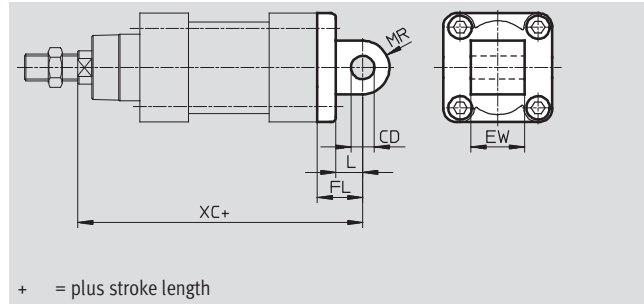

Dimensions and ordering data

For Ø	CD Ø	EW	FL	L	MR	XC	CRC ¹⁾	Weight [g]	Part No.	Type
32	10	26	22	13	10	142	2	75	151 527	SNGL-32
40	12	28	25	16	12	160	2	106	151 528	SNGL-40
50	12	32	27	16	12	170	2	183	151 529	SNGL-50
63	16	40	32	21	16	190	2	270	151 530	SNGL-63
80	16	50	36	22	16	210	2	503	151 531	SNGL-80
100	20	60	41	27	20	230	2	767	151 532	SNGL-100
125	25	70	50	30	25	275	2	1,433	151 533	SNGL-125
160	30	90	55	35	25	315	2	2,252	151 534	SNGL-160
200	30	90	60	35	25	335	2	3,306	151 535	SNGL-200







1) Corrosion resistance class 2 according to Festo standard 940 070

Components requiring moderate corrosion resistance. Externally visible parts with primarily decorative surface requirements which are in direct contact with a surrounding industrial atmosphere or media such as cooling or lubricating agents

Standard cylinders DNG/DNGL/DNGZK/DNGZS, ISO 15552

FESTO

Accessories







Ordering data – Mounting attachments				Technical data → Internet: clevis foot			
Designation	For Ø	Part No.	Type	Designation	For Ø	Part No.	Type
Clevis foot LSNG				Weld-on clevis foot LSNSG			
	32	31 740	LSNG-32		32	31 747	LSNSG-32
	40	31 741	LSNG-40		40	31 748	LSNSG-40
	50	31 742	LSNG-50		50	31 749	LSNSG-50
	63	31 743	LSNG-63		63	31 750	LSNSG-63
	80	31 744	LSNG-80		80	31 751	LSNSG-80
	100	31 745	LSNG-100		100	31 752	LSNSG-100
	125	31 746	LSNG-125		125	31 753	LSNSG-125
	160	152 599	LSNG-160		160	–	–
	200	152 600	LSNG-200		200	–	–
Clevis foot LBG				Clevis foot LNG			
	32	31 761	LBG-32		32	33 890	LNG-32
	40	31 762	LBG-40		40	33 891	LNG-40
	50	31 763	LBG-50		50	33 892	LNG-50
	63	31 764	LBG-63		63	33 893	LNG-63
	80	31 765	LBG-80		80	33 894	LNG-80
	100	31 766	LBG-100		100	33 895	LNG-100
	125	31 767	LBG-125		125	33 896	LNG-125
	160	–	–		160	–	–
	200	–	–		200	33 898	LNG-200
Clevis foot LSN				Clevis foot, right-angled LQG			
	32	5 561	LSN-32		32	31 768	LQG-32
	40	5 562	LSN-40		40	31 769	LQG-40
	50	5 563	LSN-50		50	31 770	LQG-50
	63	5 564	LSN-63		63	31 771	LQG-63
	80	5 565	LSN-80		80	31 772	LQG-80
	100	5 566	LSN-100		100	31 773	LQG-100
	125	6 987	LSN-125		125	31 774	LQG-125
	160	6 988	LSN-160		160	–	–
	200	6 989	LSN-200		200	–	–
	250	6 990	LSN-250		250	–	–
	320	6 991	LSN-320		320	–	–

Ordering data – One-way flow control valves				Technical data → Internet: grla	
	Connection		Material	Part No.	Type
	Thread	For tubing OD			
	G ¹ / ₈	3	Metal design	193 142	GRLA- ¹ / ₈ -QS-3-D
		4		193 143	GRLA- ¹ / ₈ -QS-4-D
		6		193 144	GRLA- ¹ / ₈ -QS-6-D
		8		193 145	GRLA- ¹ / ₈ -QS-8-D
	G ¹ / ₄	6		193 146	GRLA- ¹ / ₄ -QS-6-D
		8		193 147	GRLA- ¹ / ₄ -QS-8-D
		10		193 148	GRLA- ¹ / ₄ -QS-10-D
	G ³ / ₈	6		193 149	GRLA- ³ / ₈ -QS-6-D
		8		193 150	GRLA- ³ / ₈ -QS-8-D
		10		193 151	GRLA- ³ / ₈ -QS-10-D
	G ¹ / ₂	12		193 152	GRLA- ¹ / ₂ -QS-12-D

Standard cylinders DNG/DNGL/DNGZK/DNGZS, ISO 15552

FESTO

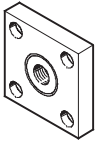
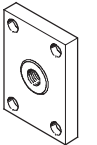
Accessories

Ordering data – Piston rod attachments				Technical data → Internet: piston-rod attachment			
Designation	For Ø	Part No.	Type	Designation	For Ø	Part No.	Type
Rod eye SGS				Rod clevis SGA			
	32	9 261	SGS-M10x1,25		32	32 954	SGA-M10x1,25
	40	9 262	SGS-M12x1,25		40	10 767	SGA-M12x1,25
	50	9 263	SGS-M16x1,5		50	10 768	SGA-M16x1,5
	63						
	80				10 769		
	100						
	125	10 774	SGS-M27x2			125	10 770
	160	10 775	SGS-M36x2		160	10 775	SGA-M36x2
	200				200		
	250	10 776	SGS-M42x2		–	–	–
320	10 777	SGS-M48x2	–	–	–		
Rod clevis SG				Self-aligning rod coupler FK			
	32	6 144	SG-M10x1,25		32	6 140	FK-M10x1,25
	40	6 145	SG-M12x1,25		40	6 141	FK-M12x1,25
	50	6 146	SG-M16x1,5		50	6 142	FK-M16x1,5
	63						
	80				6 143		
	100						
	125	14 987	SG-M27x2-B			125	10 485
	160	9 581	SG-M36x2		160	10 746	FK-M36x2
	200				200		
	250	9 582	SG-M42x2		250	–	–
320	9 583	SG-M48x2	320	–	–		
Coupling piece KSG				Coupling piece KSZ			
	32	32 963	KSG-M10x1,25		32	36 125	KSZ-M10x1,25
	40	32 964	KSG-M12x1,25		40	36 126	KSZ-M12x1,25
	50	32 965	KSG-M16x1,5		50	36 127	KSZ-M16x1,5
	63						
	80				36 128		
	100						
125	32 967	KSG-M27x2	125	–		–	
Adapter AD							
	32	157 333	AD-M10x1,25-1/8				
		157 334	AD-M10x1,25-1/4				
	40	160 256	AD-M12x1,25-1/4				
		160 257	AD-M12x1,25-3/8				

Standard cylinders DNG/DNGL/DNGZK/DNGZS, ISO 15552

FESTO

Accessories

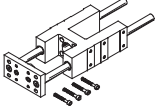

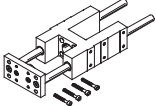
Ordering data – Guide units for fixed strokes (recirculating ball bearing guide only)				Technical data → Internet: festo		
	Stroke [mm]	Part No.	Type	Stroke [mm]	Part No.	Type
	For Ø 32 mm			For Ø 40 mm		
	10 ... 50	34 493	FENG-32-50-KF	10 ... 50	34 499	FENG-40-50-KF
	10 ... 100	34 494	FENG-32-100-KF	10 ... 100	34 500	FENG-40-100-KF
	10 ... 160	34 495	FENG-32-160-KF	10 ... 160	34 501	FENG-40-160-KF
	10 ... 200	34 496	FENG-32-200-KF	10 ... 200	34 502	FENG-40-200-KF
	10 ... 250	150 289	FENG-32-250-KF	10 ... 250	34 503	FENG-40-250-KF
	10 ... 320	34 497	FENG-32-320-KF	10 ... 320	34 504	FENG-40-320-KF
	10 ... 400	150 290	FENG-32-400-KF	10 ... 400	150 291	FENG-40-400-KF
	10 ... 500	34 498	FENG-32-500-KF	10 ... 500	34 505	FENG-40-500-KF
	For Ø 50 mm			For Ø 63 mm		
	10 ... 50	34 506	FENG-50-50-KF	10 ... 50	34 513	FENG-63-50-KF
	10 ... 100	34 507	FENG-50-100-KF	10 ... 100	34 514	FENG-63-100-KF
	10 ... 160	34 508	FENG-50-160-KF	10 ... 160	34 515	FENG-63-160-KF
	10 ... 200	34 509	FENG-50-200-KF	10 ... 200	34 516	FENG-63-200-KF
	10 ... 250	34 510	FENG-50-250-KF	10 ... 250	34 517	FENG-63-250-KF
	10 ... 320	34 511	FENG-50-320-KF	10 ... 320	34 518	FENG-63-320-KF
	10 ... 400	150 292	FENG-50-400-KF	10 ... 400	34 519	FENG-63-400-KF
	10 ... 500	34 512	FENG-50-500-KF	10 ... 500	34 520	FENG-63-500-KF
	For Ø 80 mm			For Ø 100 mm		
	10 ... 50	34 521	FENG-80-50-KF	10 ... 50	34 529	FENG-100-50-KF
	10 ... 100	34 522	FENG-80-100-KF	10 ... 100	34 530	FENG-100-100-KF
	10 ... 160	34 523	FENG-80-160-KF	10 ... 160	34 531	FENG-100-160-KF
	10 ... 200	34 524	FENG-80-200-KF	10 ... 200	34 532	FENG-100-200-KF
	10 ... 250	34 525	FENG-80-250-KF	10 ... 250	34 533	FENG-100-250-KF
	10 ... 320	34 526	FENG-80-320-KF	10 ... 320	34 534	FENG-100-320-KF
	10 ... 400	34 527	FENG-80-400-KF	10 ... 400	34 535	FENG-100-400-KF
	10 ... 500	34 528	FENG-80-500-KF	10 ... 500	34 536	FENG-100-500-KF



Ordering data – Guide units for variable strokes				Technical data → Internet: festo	
	For Ø [mm]	Stroke [mm]	With recirculating ball bearing guide Part No. Type	With sliding bearing guide Part No. Type	
	32	10 ... 500	34 487 FENG-32-...-KF	34 481 FENG-32-...	
	40	10 ... 500	34 488 FENG-40-...-KF	34 482 FENG-40-...	
	50	10 ... 500	34 489 FENG-50-...-KF	34 483 FENG-50-...	
	63	10 ... 500	34 490 FENG-63-...-KF	34 484 FENG-63-...	
	80	10 ... 500	34 491 FENG-80-...-KF	34 485 FENG-80-...	
	100	10 ... 500	34 492 FENG-100-...-KF	34 486 FENG-100-...	



Standard cylinders DNG/DNGL/DNGZK/DNGZS, ISO 15552

FESTO

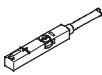
Accessories

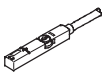
Ordering data – Connecting cables				Technical data → Internet: nebu	
	Electrical connection, left	Electrical connection, right	Cable length [m]	Part No.	Type
	Straight socket, M8x1, 3-pin	Cable, open end, 3-wire	2.5	541 333	NEBU-M8G3-K-2.5-LE3
			5	541 334	NEBU-M8G3-K-5-LE3
	Angled socket, M8x1, 3-pin	Cable, open end, 3-wire	2.5	541 338	NEBU-M8W3-K-2.5-LE3
			5	541 341	NEBU-M8W3-K-5-LE3

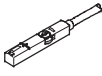
Ordering data – Proximity sensors for T-slot, magneto-resistive				Technical data → Internet: smt	
	Type of mounting	Switch output	Electrical connection	Cable length [m]	Part No. Type
N/O contact					
	Insertable in the slot from above, flush with cylinder profile	PNP	Cable, 3-wire	2.5	543 867 SMT-8M-PS-24V-K-2,5-OE
			Plug M8x1, 3-pin	0.3	543 866 SMT-8M-PS-24V-K-0,3-M8D
			Plug M12x1, 3-pin	0.3	543 869 SMT-8M-PS-24V-K-0,3-M12
		NPN	Cable, 3-wire	2.5	543 870 SMT-8M-NS-24V-K-2,5-OE
			Plug M8x1, 3-pin	0.3	543 871 SMT-8M-NS-24V-K-0,3-M8D
			Plug M12x1, 3-pin	0.3	543 872 SMT-8M-NS-24V-K-0,3-M12
	Insertable in the slot lengthwise, flush with the cylinder profile	PNP	Cable, 3-wire	2.5	175 436 SMT-8-PS-K-LED-24-B
			Plug M8x1, 3-pin	0.3	175 484 SMT-8-PS-S-LED-24-B
N/C contact					
	Insertable in the slot from above, flush with cylinder profile	PNP	Cable, 3-wire	7.5	543 873 SMT-8M-PO-24V-K7,5-OE

Ordering data – Proximity sensors for T-slot, magnetic reed				Technical data → Internet: sme	
	Type of mounting	Switch output	Electrical connection	Cable length [m]	Part No. Type
N/O contact					
	Insertable in the slot from above, flush with cylinder profile	Contacting	Cable, 3-wire	2.5	543 862 SME-8M-DS-24V-K-2,5-OE
			Cable, 3-wire	5.0	543 863 SME-8M-DS-24V-K-5,0-OE
			Plug M8x1, 3-pin	0.3	543 861 SME-8M-DS-24V-K-0,3-M8D
			Plug M12x1, 3-pin	0.3	543 864 SME-8M-DS-24V-K-0,3-M12
	Insertable in the slot lengthwise, flush with the cylinder profile	Contacting	Cable, 3-wire	2.5	150 855 SME-8-K-LED-24
			Plug M8x1, 3-pin	0.3	150 857 SME-8-S-LED-24
N/C contact					
	Insertable in the slot lengthwise, flush with the cylinder profile	Contacting	Cable, 3-wire	7.5	160 251 SME-8-O-K-LED-24

Ordering data – Mounting kits for proximity sensors SME/SMT-8			Technical data → Internet: smbz	
	For Ø	Materials	Part No.	Type
	32 ... 100 mm	Rail: Wrought aluminium alloy, anodised	537 806	SMBZ-8-32/100
	125 ... 320 mm	Screws: High-alloy steel Free of copper and PTFE	537 808	SMBZ-8-125/320

Standard cylinders DNG/DNGL/DNGZK/DNGZS, ISO 15552

FESTO

Accessories

Ordering data – Rectangular proximity sensors, magneto-resistive						Technical data → Internet: smto	
	Mounting	Switch output	Electrical connection		Cable length [m]	Part No.	Type
			Cables	M8 plug			
NO contact							
	Via accessories	PNP	3-wire	–	2.5	151 683	SMTO-1-PS-K-LED-24-C
			–	3-pin	–	151 685	SMTO-1-PS-S-LED-24-C
		NPN	3-wire	–	2.5	151 684	SMTO-1-NS-K-LED-24-C
			–	3-pin	–	151 686	SMTO-1-NS-S-LED-24-C

Ordering data – Rectangular proximity sensors, magnetic reed						Technical data → Internet: smeo	
	Mounting	Electrical connection		Cable length [m]	Part No.	Type	
		Cables	M8 plug				
NO contact							
	Via accessories	3-wire	–	2.5	30 459	SMEO-1-LED-24-B	
		3-wire	–	5.0	151 672	SMEO-1-LED-24-K5-B	
		–	3-pin	–	150 848	SMEO-1-S-LED-24-B	

Ordering data – Mounting kits for proximity sensors SMEO/SMTO-1				Technical data → Internet: smb	
	For Ø	Mounting		Part No.	Type
	32 ... 50 mm	Directly on the mounting or tie rod		36 162	SMB-2-B
	125 ... 320 mm			11 886	SMB-1
	63 ... 100 mm			36 163	SMB-3-B

Ordering data – Rectangular proximity sensors, pneumatic				Technical data → Internet: smpo	
	Mounting	Pneumatic connection		Part No.	Type
3/2-way valve, normally closed					
	Via accessories	Barbed fitting for tubing ID of 3 mm		31 008	SMPO-1-H-B

Ordering data – Mounting kits for proximity sensors SMPO-1				Technical data → Internet: smbs	
	For Ø	Mounting		Part No.	Type
	32 ... 100 mm	On the cylinder barrel via clamping strap		151 226	SMBS-2

Ordering data – Mounting kits for proximity sensors SME/SMT-8				Technical data → Internet: smbr	
	For Ø	Mounting	CRC ¹⁾	Part No.	Type
	32 ... 100 mm	On the cylinder barrel via clamping strap	4	538 937	SMBR-8-8/100-S6

1) Corrosion resistance class 4 according to Festo standard 940 070
Components requiring higher corrosion resistance. Parts used with aggressive media, e.g. food or chemical industry. These applications should be supported with special tests with the media if required

Product Range and Company Overview

A Complete Suite of Automation Services

Our experienced engineers provide complete support at every stage of your development process, including: conceptualization, analysis, engineering, design, assembly, documentation, validation, and production.



Custom Automation Components
Complete custom engineered solutions



Custom Control Cabinets
Comprehensive engineering support and on-site services



Complete Systems
Shipment, stocking and storage services

The Broadest Range of Automation Components

With a comprehensive line of more than 30,000 automation components, Festo is capable of solving the most complex automation requirements.



Electromechanical
Electromechanical actuators, motors, controllers & drives



Pneumatics
Pneumatic linear and rotary actuators, valves, and air supply



PLCs and I/O Devices
PLC's, operator interfaces, sensors and I/O devices

Supporting Advanced Automation... As No One Else Can!

Festo is a leading global manufacturer of pneumatic and electromechanical systems, components and controls for industrial automation, with more than 12,000 employees in 56 national headquarters serving more than 180 countries. For more than 80 years, Festo has continuously elevated the state of manufacturing with innovations and optimized motion control solutions that deliver higher performing, more profitable automated manufacturing and processing equipment. Our dedication to the advancement of automation extends beyond technology to the education and development of current and future automation and robotics designers with simulation tools, teaching programs, and on-site services.

Quality Assurance, ISO 9001 and ISO 14001 Certifications

Festo Corporation is committed to supply all Festo products and services that will meet or exceed our customers' requirements in product quality, delivery, customer service and satisfaction.

To meet this commitment, we strive to ensure a consistent, integrated, and systematic approach to management that will meet or exceed the requirements of the ISO 9001 standard for Quality Management and the ISO 14001 standard for Environmental Management.



© Copyright 2008, Festo Corporation. While every effort is made to ensure that all dimensions and specifications are correct, Festo cannot guarantee that publications are completely free of any error, in particular typing or printing errors. Accordingly, Festo cannot be held responsible for the same. For Liability and Warranty conditions, refer to our "Terms and Conditions of Sale", available from your local Festo office. All rights reserved. No part of this publication may be reproduced, distributed, or transmitted in any form or by any means, electronic, mechanical, photocopying or otherwise, without the prior written permission of Festo. All technical data subject to change according to technical update.



Printed on recycled paper at New Horizon Graphic, Inc., FSC certified as an environmentally friendly printing plant.

Festo North America

Festo Regional Contact Center

5300 Explorer Drive
Mississauga, Ontario L4W 5G4
Canada

USA Customers:

For ordering assistance,

Call: 1.800.99.FESTO (1.800.993.3786)

Fax: 1.800.96.FESTO (1.800.963.3786)

Email: customer.service@us.festo.com

For technical support,

Call: 1.866.GO.FESTO (1.866.463.3786)

Fax: 1.800.96.FESTO (1.800.963.3786)

Email: product.support@us.festo.com

Canadian Customers:

Call: 1.877.GO.FESTO (1.877.463.3786)

Fax: 1.877.FX.FESTO (1.877.393.3786)

Email: festo.canada@ca.festo.com

USA Headquarters

Festo Corporation
395 Moreland Road
P.O. Box 18023
Hauppauge, NY 11788, USA
www.festo.com/us

USA Sales Offices

Appleton

North 922 Tower View Drive, Suite N
Greenville, WI 54942, USA

Boston

120 Presidential Way, Suite 330
Woburn, MA 01801, USA

Chicago

1441 East Business Center Drive
Mt. Prospect, IL 60056, USA

Dallas

1825 Lakeway Drive, Suite 600
Lewisville, TX 75057, USA

Detroit – Automotive Engineering Center

2601 Cambridge Court, Suite 320
Auburn Hills, MI 48326, USA

New York

395 Moreland Road
Hauppauge, NY 11788, USA

Silicon Valley

4935 Southfront Road, Suite F
Livermore, CA 94550, USA

United States



USA Headquarters, East: Festo Corp., 395 Moreland Road, Hauppauge, NY 11788

Phone: 1.631.435.0800; Fax: 1.631.435.8026;

Email: info@festo-usa.com

www.festo.com/us

Canada



Headquarters: Festo Inc., 5300 Explorer Drive, Mississauga, Ontario L4W 5G4

Phone: 1.905.624.9000; Fax: 1.905.624.9001;

Email: festo.canada@ca.festo.com

www.festo.ca

Mexico



Headquarters: Festo Pneumatic, S.A., Av. Ceylán 3, Col. Tequesquahuac,
54020 Tlalneantla, Edo. de México

Phone: 011 52 [55] 53 21 66 00; Fax: 011 52 [55] 53 21 66 65;

Email: festo.mexico@mx.festo.com

www.festo.com/mx

Central USA

Festo Corporation
1441 East Business
Center Drive
Mt. Prospect, IL 60056, USA
Phone: 1.847.759.2600
Fax: 1.847.768.9480



Western USA

Festo Corporation
4935 Southfront Road,
Suite F
Livermore, CA 94550, USA
Phone: 1.925.371.1099
Fax: 1.925.245.1286



Festo Worldwide

Argentina Australia Austria Belarus Belgium Brazil Bulgaria Canada Chile China Colombia Croatia Czech Republic Denmark
Estonia Finland France Germany Great Britain Greece Hong Kong Hungary India Indonesia Iran Ireland Israel Italy Japan Latvia
Lithuania Malaysia Mexico Netherlands New Zealand Norway Peru Philippines Poland Romania Russia Serbia Singapore
Slovakia Slovenia South Africa South Korea Spain Sweden Switzerland Taiwan Thailand Turkey Ukraine United States Venezuela

www.festo.com