

Slide units SPZ, twin piston



Slide units SPZ, twin piston

Key features

Multi-axis and drive combinations

The slide unit SPZ can be combined with different drives. An adapter kit is required for mounting between the two drives.

DPZ-/SPZ axis

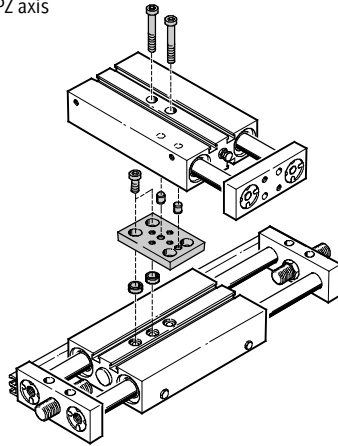

Adapter kits

→ www.festo.com

Shock absorbers for slide operation

- From 30 ... 900 mm/s
- In slide operation, shock absorbers provide highly dynamic but gentle operating characteristics

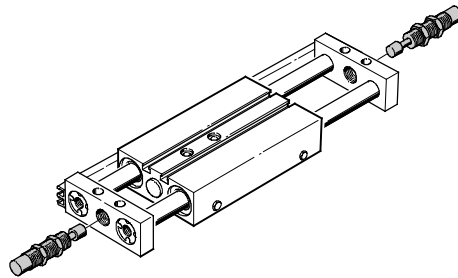

Slide operation SPZ-...

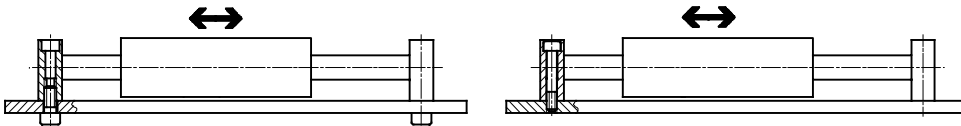

Slide units SPZ, twin piston

Overview and type codes

Function	Version	Piston Ø [mm]	Stroke [mm]	Position sensing A	Plain bearing guide GF	Recirculating ball bearing guide KF
Double-acting		10	10, 25, 40, 50	■	■	■
		16, 20, 25, 32	10, 25, 40, 50, 80, 100			

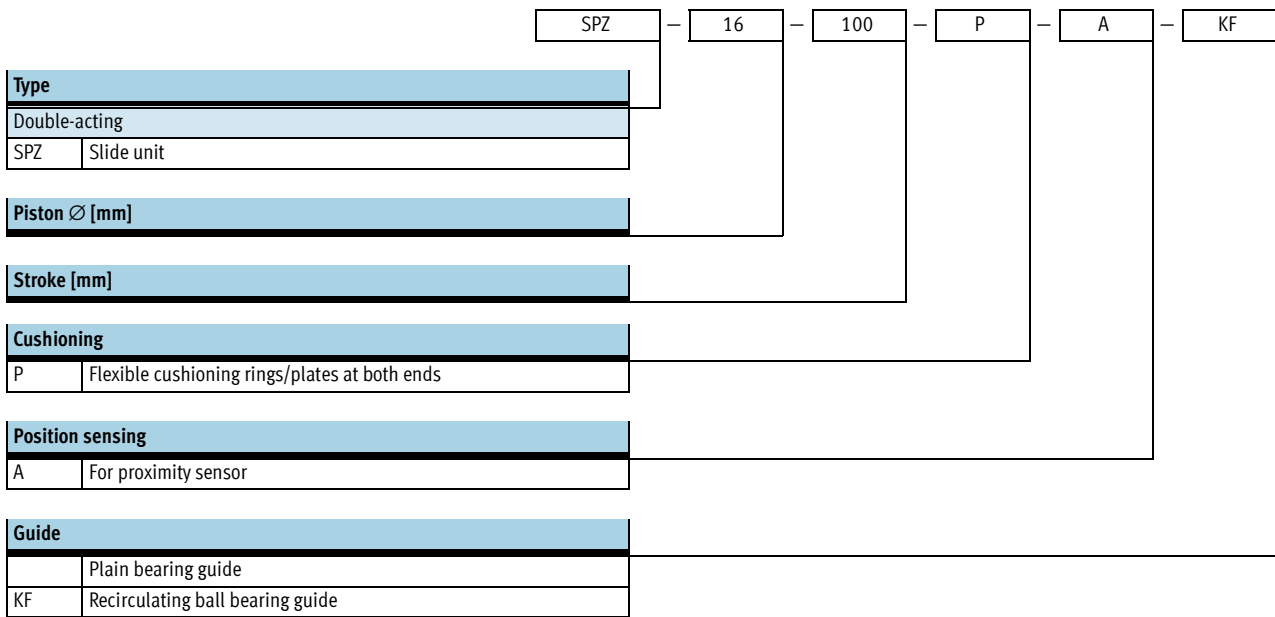

Slide units SPZ, twin piston

Peripherals overview

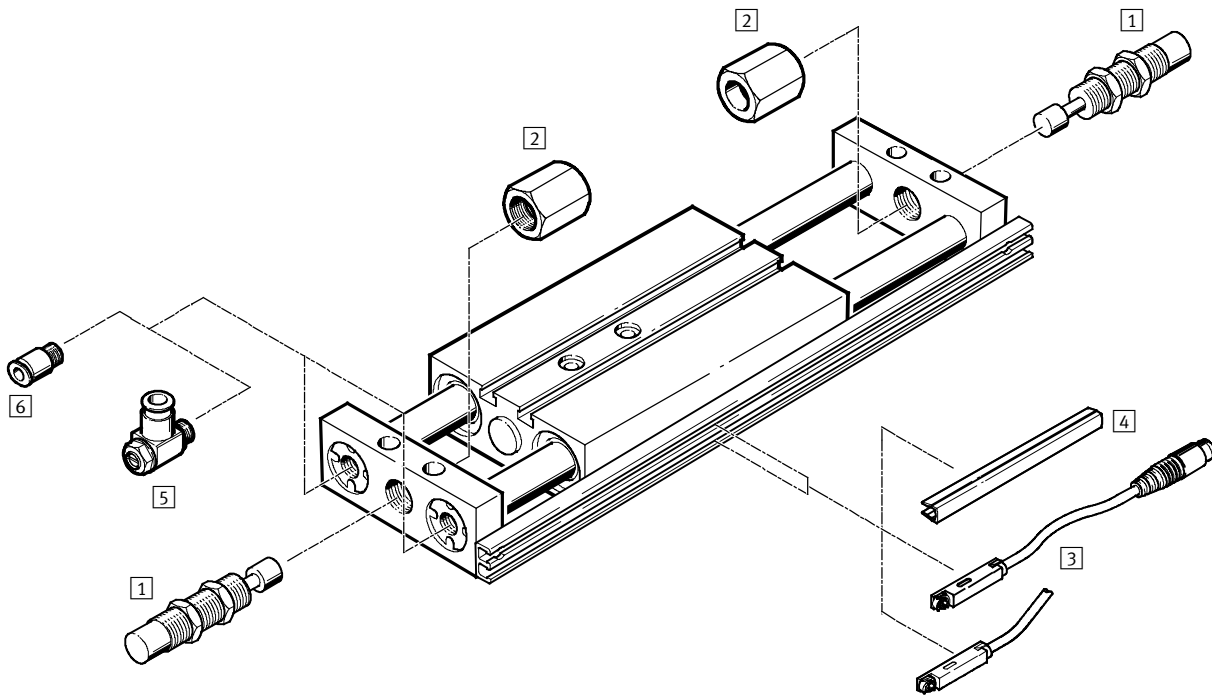



Accessories					
	Brief description	Piston Ø		→ Page/Internet	
		10, 16 mm	20, 25, 32 mm		
1	Shock absorber YSR-C	Hydraulic shock absorber with rapidly increasing cushioning characteristic	■	■	13
2	Stop limiters YSRA	Stroke limiter for shock absorber	■	■	13
3	Proximity sensor SME/SMT-8	Can be integrated in the cylinder profile barrel	■	■	14
4	Slot cover ABP-5-S	To protect the sensor cable and keep dirt out of the sensor slots	■	■	14
5	One-way flow control valve GRLA	To regulate speed	■	■	15
6	Push-in fitting QS	For connecting compressed air tubing with standard O.D.	■	■	quick star
-	Centring pin ZBS	2 pieces included in scope of delivery	■	-	15
-	Centring sleeve ZBH	2 pieces included in scope of delivery	-	■	15

Slide units SPZ, twin piston

Technical data

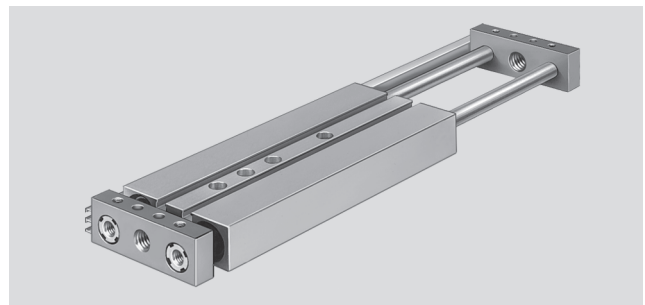
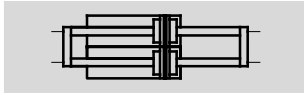
Function



-  - Diameter
10 ... 32 mm

-  - Stroke length
10 ... 100 mm

-  - www.festo.com

General technical data					
Piston \varnothing	10	16	20	25	32
Pneumatic connection	M5	M5	M5	M5	G $\frac{1}{8}$
Operating medium	Compressed air in accordance with ISO 8573-1:2010 [7:4:4]				
Note on operating/pilot medium	Operation with lubricated medium possible (in which case lubricated operation will always be required)				
Operating pressure [bar]	2,5 ... 10	1 ... 10			
Constructional design	Slide				
	Parallel piston rods				
Cushioning	Flexible cushioning rings/plates at both ends				
Position sensing	For proximity sensing				
Type of mounting	Via through-holes				
	With female thread				
	With mounting plate				
Mounting position	Any				
Protection against torsion/guide	Parallel piston rods/with plain-bearing guide or ball bearing guide				

Ambient conditions		
Variant	Plain-bearing guide GF	Recirculating ball bearing guide KF
Ambient temperature ¹⁾ [°C]	-20 ... +80	
Corrosion resistance class CRC ²⁾	2	-
ATEX	Specified types → www.festo.com	

1) Note operating range of proximity sensors.

2) Corrosion resistance class 2 according to Festo standard 940 070

Components requiring moderate corrosion resistance. Externally visible parts with primarily decorative surface requirements which are in direct contact with a surrounding industrial atmosphere or media such as cooling or lubricating agents.

Forces [N]					
Piston \varnothing	10	16	20	25	32
Theoretical force at 6 bar, advancing	60	180	282	452	724
Theoretical force at 6 bar, retracting	60	180	282	452	724

Slide units SPZ, twin piston

Technical data

Permissible lateral force F_Q as a function of stroke l

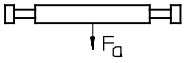

Plain-bearing guide GF

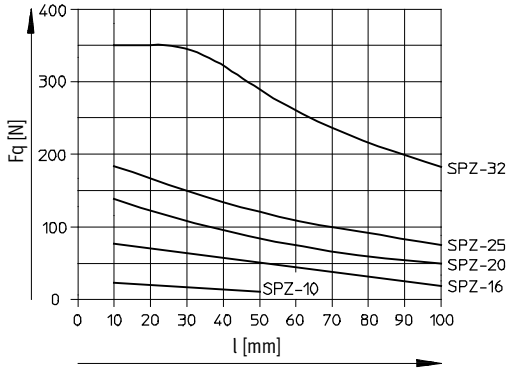

Recirculating ball bearing guide KF

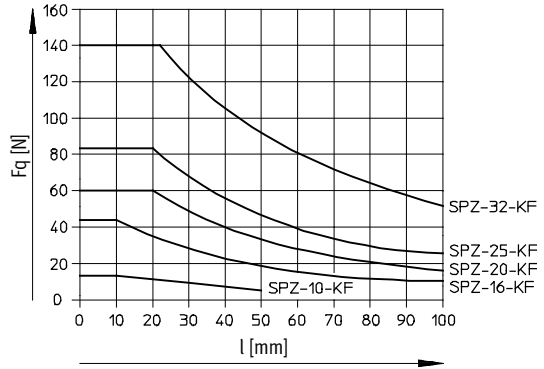

Permissible torque M_L as a function of stroke l

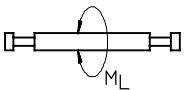

Plain-bearing guide GF

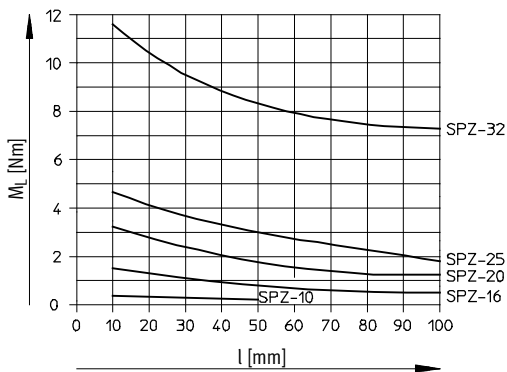

Recirculating ball bearing guide KF

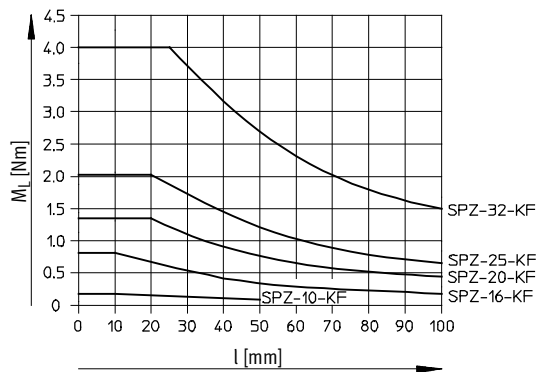

Slide units SPZ, twin piston

Technical data

Materials

Sectional view

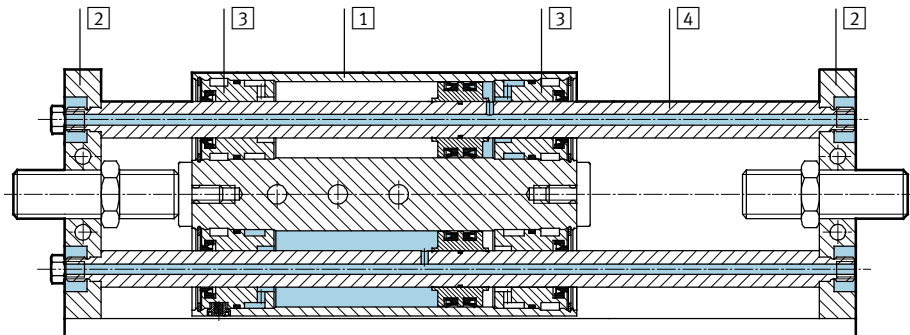

Slide unit

1	Housing		Wrought aluminium alloy
2	Yoke plate		Tool steel
3	Plug cap	GF	Brass
		KF	Wrought aluminium alloy
4	Piston rod	GF	High-alloy stainless steel
		KF	Tempered steel
-	Seals		Polyurethane, nitrile rubber

Slide units SPZ, twin piston

Technical data



Dimensions

Download CAD data → www.festo.com

Piston Ø 10, 16 mm, plain-bearing guide GF

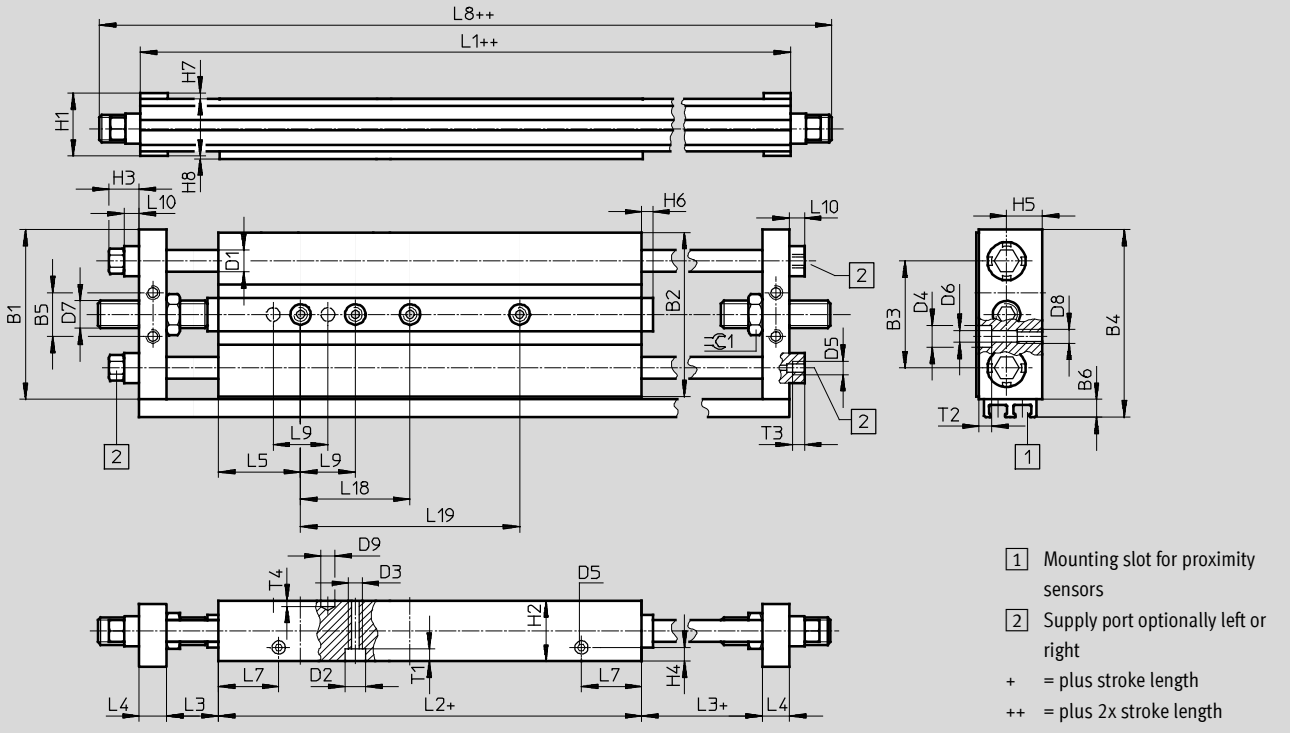

Ø	B1	B2	B3	B4	B5	B6	D1	D2	D3	D4	D5	D6	D7	D8	D9	H1	H2	H3
[mm]							Ø	Ø		Ø		Ø			Ø			
10	52	50	33	58.5	16	6.5	6	7.5	M5	8	M5	4.2	M10x1	M5	5	20	19	10
16	62	60	39	68.5	16	6.5	8	7.5	M5	8	M5	4.2	M10x1	M5	5	23	22	11

Ø	H4	H5	H6	H7	H8	L1	L2	L3	L4	L5	L7	L8	L9 ¹⁾	L10	T1	T2	T3	T4	≲C1
[mm]																			
10	5	11.5	4	2	1	129.6	71.6	19	10	30	23.4	159.6	20	4.5	4.4	3.4	5	2	13
16	5	13	4	2	1	132.6	74.6	19	10	30	22	162.6	20	5.5	4.4	4.6	4.5	2	13

Stroke	L18 ¹⁾	L19 ¹⁾
[mm]	±0.03	±0.03
10	-	-
25	-	-
40	40	-
50	40	-
80	40	80
100	40	80

1) Tolerance for centring hole ±0.03 mm
Tolerance for thread ±0.2 mm

Slide units SPZ, twin piston

Technical data



Dimensions

Download CAD data → www.festo.com

Piston Ø 20, 25, 32 mm, plain-bearing guide GF

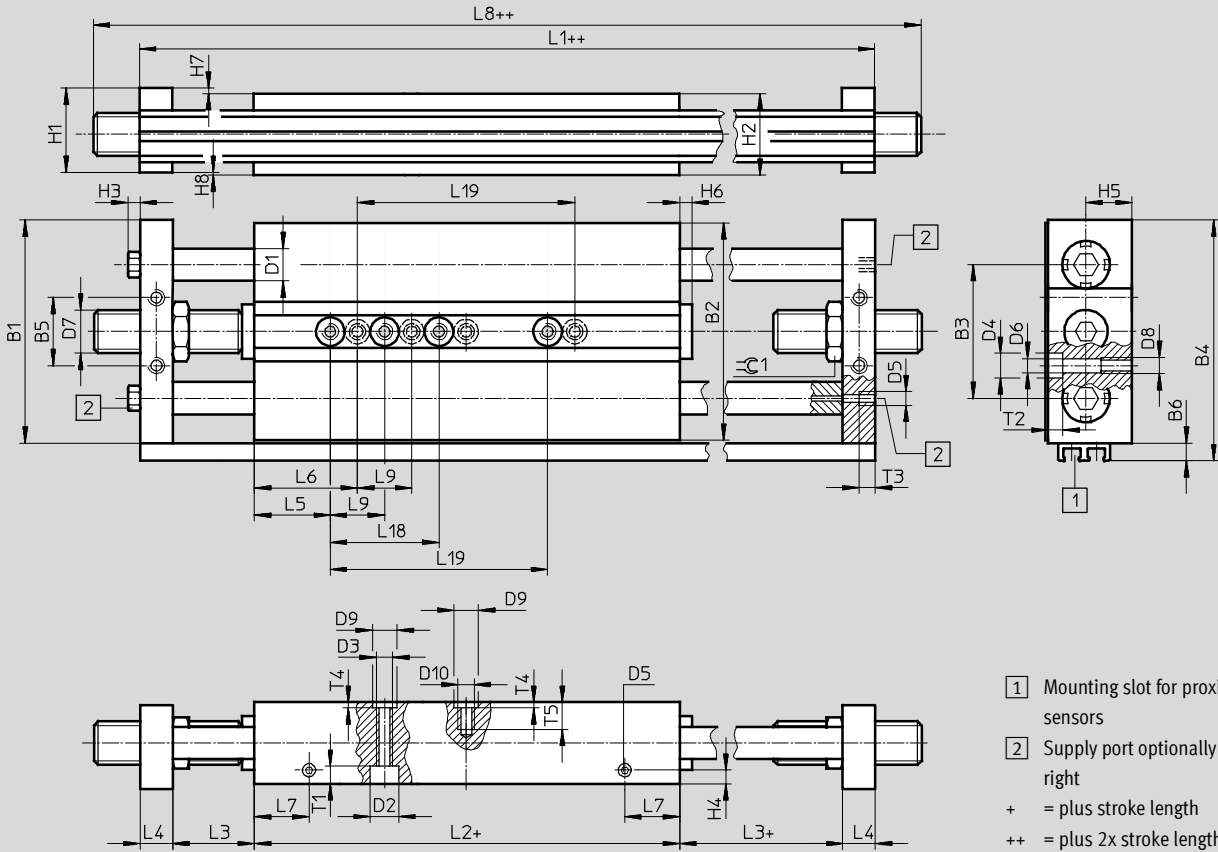

Ø	B1	B2	B3	B4	B5	B6	D1	D2	D3	D4	D5	D6	D7	D8	D9	D10	H1	H2	H3
[mm]							Ø	Ø	Ø	Ø		Ø		Ø	Ø				
20	74	72	45.6	80.5	23	6.5	10	9	M6	9.5	M5	5.2	M12x1	M6	9	M6	25	24	5
25	82	80	49.2	88.5	25	6.5	12	10.5	6.4	9.5	M5	5.2	M16x1	M6	9	M6	31	30	5
32	100	98	57	106.5	24	6.5	16	10.5	6.4	10.5	G1/8	6.2	M16x1	M8	9	M6	39	38	-

Ø	H4	H5	H6	H7	H8	L1	L2	L3	L4	L5	L6	L7	L8	L9 ¹⁾	T1	T2	T3	T4	T5	≙C1
[mm]																				
20	5	14	4	2	1	146.6	76.6	23	12	30	-	22.8	178.6	20	5.4	5	6	2.1	10	15
25	5	17	4.5	2	1	160.6	76.6	30	12	28	38	20.2	194.6	20	6.4	5	6	2.1	10	19
32	7.5	21	4.5	2	1	170.1	80.1	30	15	35	45	25	204.1	20	6.4	6.5	10	2.1	10	19

Stroke	L18 ¹⁾	L19 ¹⁾
[mm]	±0.03	±0.03
10	-	-
25	-	-
40	40	-
50	40	-
80	40	80
100	40	80

1) Tolerance for centring hole ±0.03 mm
 Tolerance for thread ±0.2 mm

Slide units SPZ, twin piston

Technical data

Dimensions

Download CAD data → www.festo.com

Piston Ø 20, 25, 32 mm, recirculating ball bearing guide KF

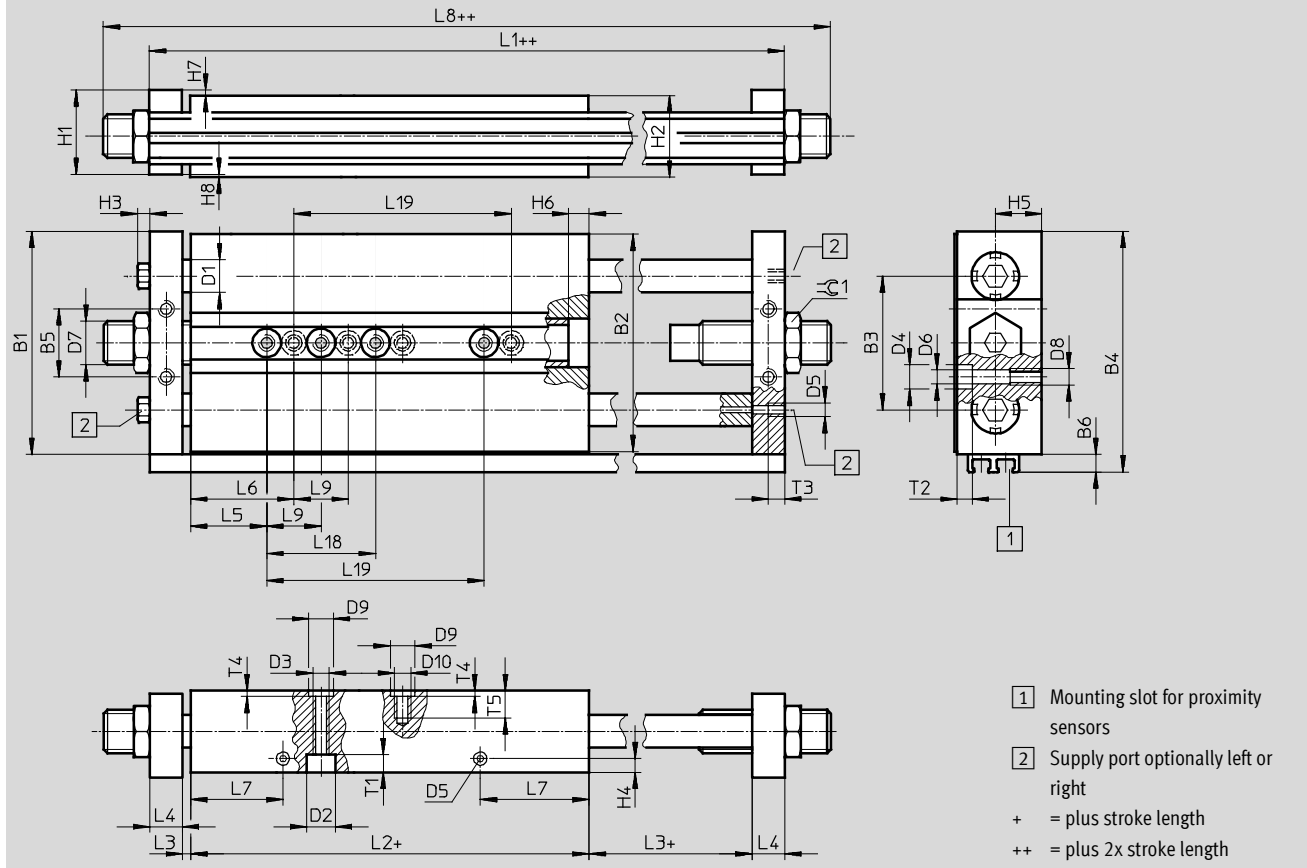

Ø	B1	B2	B3	B4	B5	B6	D1	D2	D3	D4	D5	D6	D7	D8	D9	D10	H1	H2	H3
[mm]							Ø	Ø	Ø	Ø		Ø			Ø				
20	74	72	45.6	80.5	23	6.5	10	9	M6	9.5	M5	5.2	M12x1	M6	9	M6	25	24	5
25	82	80	49.2	88.5	25	6.5	12	10.5	6.4	9.5	M5	5.2	M16x1	M6	9	M6	31	30	5
32	100	98	57	106.5	24	6.5	16	10.5	6.4	10.5	G $\frac{1}{8}$	6.2	M16x1	M8	9	M6	39	38	-

Ø	H4	H5	H6	H7	H8	L1	L2	L3	L4	L5	L6	L7	L8	L9 ¹⁾	T1	T2	T3	T4	T5	≈1
[mm]																				
20	5	14	6.5	2	1	146.6	120.6	1	12	30	-	43.4	184.6	20	5.4	5	6	2.1	10	15
25	5	17	7.5	2	1	160.6	130.6	3	12	28	38	40	202.6	20	6.4	5	6	2.1	10	19
32	7.5	21	7.5	2	1	170.1	134.1	3	15	35	45	44.9	206.1	20	6.4	6.5	10	2.1	10	19

Stroke	L18 ¹⁾	L19 ¹⁾
[mm]	±0.03	±0.03
10	-	-
25	-	-
40	40	-
50	40	-
80	40	80
100	40	80

1) Tolerance for centring hole ±0.03 mm
 Tolerance for thread ±0.2 mm

Slide units SPZ, twin piston

Technical data

Ordering data						
Type	Piston Ø [mm]	Stroke [mm]	Plain-bearing guide GF		Recirculating ball bearing guide KF	
			Part No.	Type ¹⁾	Part No.	Type ¹⁾
	10	10	32 714	SPZ-10-10-P-A	162 166	SPZ-10-10-P-A-KF
		25	32 715	SPZ-10-25-P-A	162 167	SPZ-10-25-P-A-KF
		40	32 716	SPZ-10-40-P-A	162 168	SPZ-10-40-P-A-KF
		50	32 717	SPZ-10-50-P-A	162 169	SPZ-10-50-P-A-KF
	16	10	32 719	SPZ-16-10-P-A	162 171	SPZ-16-10-P-A-KF
		25	32 720	SPZ-16-25-P-A	162 172	SPZ-16-25-P-A-KF
		40	32 721	SPZ-16-40-P-A	162 173	SPZ-16-40-P-A-KF
		50	32 722	SPZ-16-50-P-A	162 174	SPZ-16-50-P-A-KF
		80	32 723	SPZ-16-80-P-A	162 175	SPZ-16-80-P-A-KF
		100	32 724	SPZ-16-100-P-A	162 176	SPZ-16-100-P-A-KF
	20	10	32 726	SPZ-20-10-P-A	162 178	SPZ-20-10-P-A-KF
		25	32 727	SPZ-20-25-P-A	162 179	SPZ-20-25-P-A-KF
		40	32 728	SPZ-20-40-P-A	162 180	SPZ-20-40-P-A-KF
		50	32 729	SPZ-20-50-P-A	162 181	SPZ-20-50-P-A-KF
		80	32 730	SPZ-20-80-P-A	162 182	SPZ-20-80-P-A-KF
		100	32 731	SPZ-20-100-P-A	162 183	SPZ-20-100-P-A-KF
	25	10	32 733	SPZ-25-10-P-A	162 185	SPZ-25-10-P-A-KF
		25	32 734	SPZ-25-25-P-A	162 186	SPZ-25-25-P-A-KF
		40	32 735	SPZ-25-40-P-A	162 187	SPZ-25-40-P-A-KF
		50	32 736	SPZ-25-50-P-A	162 188	SPZ-25-50-P-A-KF
		80	32 737	SPZ-25-80-P-A	162 189	SPZ-25-80-P-A-KF
		100	32 738	SPZ-25-100-P-A	162 190	SPZ-25-100-P-A-KF
	32	10	159 721	SPZ-32-10-P-A	162 192	SPZ-32-10-P-A-KF
		25	159 722	SPZ-32-25-P-A	162 193	SPZ-32-25-P-A-KF
		40	159 723	SPZ-32-40-P-A	162 194	SPZ-32-40-P-A-KF
		50	159 724	SPZ-32-50-P-A	162 195	SPZ-32-50-P-A-KF
		80	159 725	SPZ-32-80-P-A	162 196	SPZ-32-80-P-A-KF
		100	159 726	SPZ-32-100-P-A	162 197	SPZ-32-100-P-A-KF

1) 2 centring pins or sleeves are included in the scope of delivery.

Slide units SPZ, twin piston

Accessories

Shock absorber YSR-C

Material:
 YSR-7-5-C, YSR-8-8-C: Nickel-plated brass
 YSR-12-12-C: Galvanised steel
 Free of copper, PTFE and silicone

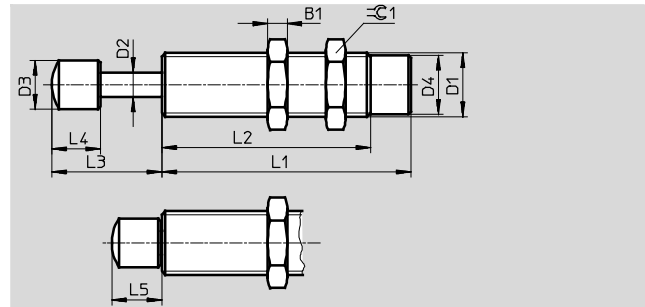

Dimensions and ordering data												Part No.	Type
For \varnothing	B1	D1	D2 \varnothing	D3 \varnothing	D4 \varnothing	L1 ± 0.1	L2 ± 0.3	L3 $+0.7/-0.35$	L4 ± 0.2	L5 $+0.55/-0.25$	\approx		
[mm]													
10, 16	3.5	M10x1	3	6 ± 0.1	8.6 ± 0.05	34	23	12.3	7	7.3	13	160 272	YSR-7-5-C
20	4	M12x1	4	8 ± 0.2	10.4 ± 0.1	46	33	16.3	8	8.3	15	34 571	YSR-8-8-C
25, 32	5	M16x1	6	12 ± 0.2	14.5 ± 0.1	64	51	24.5	12	12.5	19	34 572	YSR-12-12-C

Stop limiter YSRA

for use when shock absorbers are fitted
 (not in the case of recirculating ball bearing guide)

Material:
 Steel

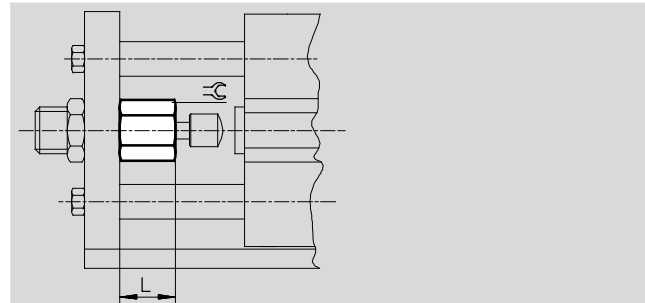
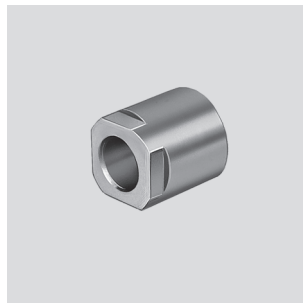





Dimensions and ordering data					
For \varnothing	L	\approx	For shock absorbers	Weight	Part No. Type
[mm]				[g]	
10, 16	15	13	YSR-7-5-C	12	150 932 YSRA-7-C
20	19	15	YSR-8-8-C	28	150 933 YSRA-8-C
25, 32	25.5	19	YSR-12-12-C	48	150 934 YSRA-12-C

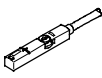

Slide units SPZ, twin piston

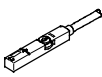
Accessories

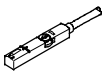
FESTO

Ordering data – Proximity sensors for T-slot, magneto-resistive						Technical data → Internet: smt
	Type of mounting	Switch output	Electrical connection	Cable length [m]	Part No.	Type
N/O contact						
	Insertable in the slot from above, flush with cylinder profile	PNP	Cable, 3-wire	2.5	543 867	SMT-8M-PS-24V-K-2,5-OE
			Plug M8x1, 3-pin	0.3	543 866	SMT-8M-PS-24V-K-0,3-M8D
			Plug M12x1, 3-pin	0.3	543 869	SMT-8M-PS-24V-K-0,3-M12
		NPN	Cable, 3-wire	2.5	543 870	SMT-8M-NS-24V-K-2,5-OE
			Plug M8x1, 3-pin	0.3	543 871	SMT-8M-NS-24V-K-0,3-M8D
			Plug M12x1, 3-pin	0.3	543 872	SMT-8M-NS-24V-K-0,3-M12
	Insertable in the slot lengthwise, flush with the cylinder profile	PNP	Cable, 3-wire	2.5	175 436	SMT-8-PS-K-LED-24-B
			Plug M8x1, 3-pin	0.3	175 484	SMT-8-PS-S-LED-24-B
N/C contact						
	Insertable in the slot from above, flush with cylinder profile	PNP	Cable, 3-wire	7.5	543 873	SMT-8M-PO-24V-K7,5-OE

Ordering data – Proximity sensors for T-slot, magnetic reed						Technical data → Internet: sme	
	Type of mounting	Switch output	Electrical connection	Cable length [m]	Part No.	Type	
N/O contact							
	Insertable in the slot from above, flush with cylinder profile	Contacting	Cable, 3-wire	2.5	543 862	SME-8M-DS-24V-K-2,5-OE	
				5.0	543 863	SME-8M-DS-24V-K-5,0-OE	
			Plug M8x1, 3-pin	Cable, 2-wire	2.5	543 872	SME-8M-ZS-24V-K-2,5-OE
				0.3	543 861	SME-8M-DS-24V-K-0,3-M8D	
	Insertable in the slot lengthwise, flush with the cylinder profile	Contacting	Cable, 3-wire	2.5	150 855	SME-8-K-LED-24	
			Plug M8x1, 3-pin	0.3	150 857	SME-8-S-LED-24	
N/C contact							
	Insertable in the slot lengthwise, flush with the cylinder profile	Contacting	Cable, 3-wire	7.5	160 251	SME-8-O-K-LED-24	

Ordering data – Connecting cables					Technical data → Internet: nebu
	Electrical connection, left	Electrical connection, right	Cable length [m]	Part No.	Type
	Straight socket, M8x1, 3-pin	Cable, open end, 3-wire	2.5	541 333	NEBU-M8G3-K-2.5-LE3
			5	541 334	NEBU-M8G3-K-5-LE3
	Straight socket, M12x1, 5-pin	Cable, open end, 3-wire	2.5	541 363	NEBU-M12G5-K-2.5-LE3
			5	541 364	NEBU-M12G5-K-5-LE3
	Angled socket, M8x1, 3-pin	Cable, open end, 3-wire	2.5	541 338	NEBU-M8W3-K-2.5-LE3
			5	541 341	NEBU-M8W3-K-5-LE3
	Angled socket, M12x1, 5-pin	Cable, open end, 3-wire	2.5	541 367	NEBU-M12W5-K-2.5-LE3
			5	541 370	NEBU-M12W5-K-5-LE3



Ordering data – Slot cover for T-slot				
	Mounting	Length	Part No.	Type
	Insertable from above	2x 0.5 m	151 680	ABP-5-S

Slide units SPZ, twin piston

Accessories



Ordering data – One-way flow control valves				Technical data → Internet: grla	
	Connection		Material	Part No.	Type
	Thread	For tubing O.D.			
	M5	3	Metal design	193 137	GRLA-M5-QS-3-D
		4		193 138	GRLA-M5-QS-4-D
		6		193 139	GRLA-M5-QS-6-D
	G $\frac{1}{8}$	3		193 142	GRLA-$\frac{1}{8}$-QS-3-D
		4		193 143	GRLA-$\frac{1}{8}$-QS-4-D
		6		193 144	GRLA-$\frac{1}{8}$-QS-6-D
		8		193 145	GRLA-$\frac{1}{8}$-QS-8-D

Ordering data – Accessories				Technical data → Internet: zbs	
	For dia. [mm]	Material	Part No.	Type	PE ¹⁾
Centring pin ZBS					
	10, 16	Stainless steel Free of copper, PTFE and silicone	150 928	ZBS-5	10
Centring sleeve ZBH					
	20, 25, 30	Stainless steel Free of copper, PTFE and silicone	150 927	ZBH-9	10

1) Packaging unit quantity