

Parallel kinematic robots EXPT, tripod



# Parallel kinematic robots EXPT, tripod

Key features

### At a glance

The high-speed handling unit with robot functionality for free movement in three dimensions provides precision in movement and positioning as well as a high dynamic response of up to 150 picks/min.

The highly rigid mechanical design and low moving mass make the parallel kinematic robot with toothed belt axes in delta arrangement up to three times as fast as comparable Cartesian systems.

Three double rods keep the front unit horizontal at all times. The axes and servo motors do not move with the unit.

The parallel kinematic robots are suitable for handling loads of up to max. 5 kg.

Typical applications include:

- Picking & placing small parts
- Bonding
- Labelling
- Palletising
- Sorting
- Grouping
- Repositioning and separating

### Comparison between parallel kinematic and Cartesian systems

#### Parallel kinematic robot

- Low moving mass – ideal for demanding requirements on dynamic response in three dimensions
- High path accuracy with a range of path profiles, even for highly dynamic operation
- Four sizes with a working space diameter of up to 1,200 mm

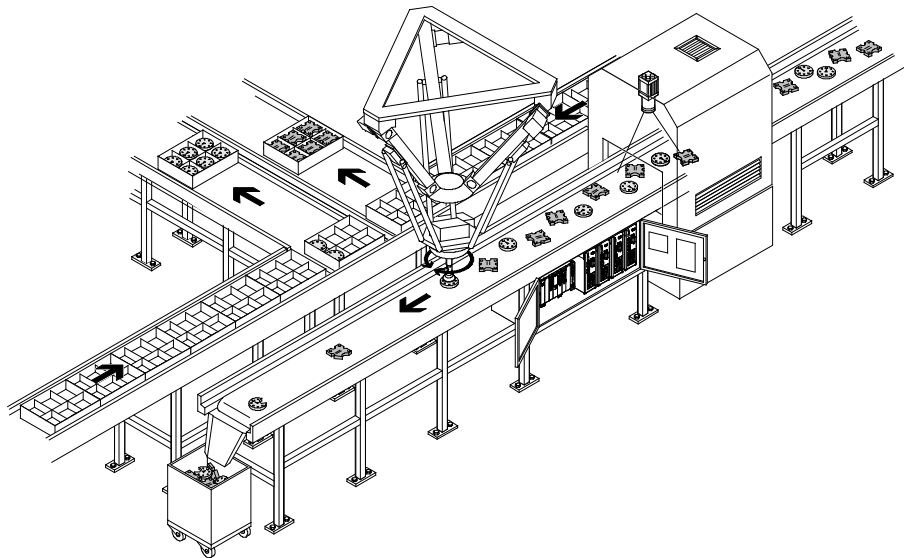

#### Cartesian system

- Axes build on one another; the first axis carries all the subsequent axes
- High moving mass, therefore much lower dynamic response
- Rectangular, scalable working space
- Based on standard components
- Flexible designs

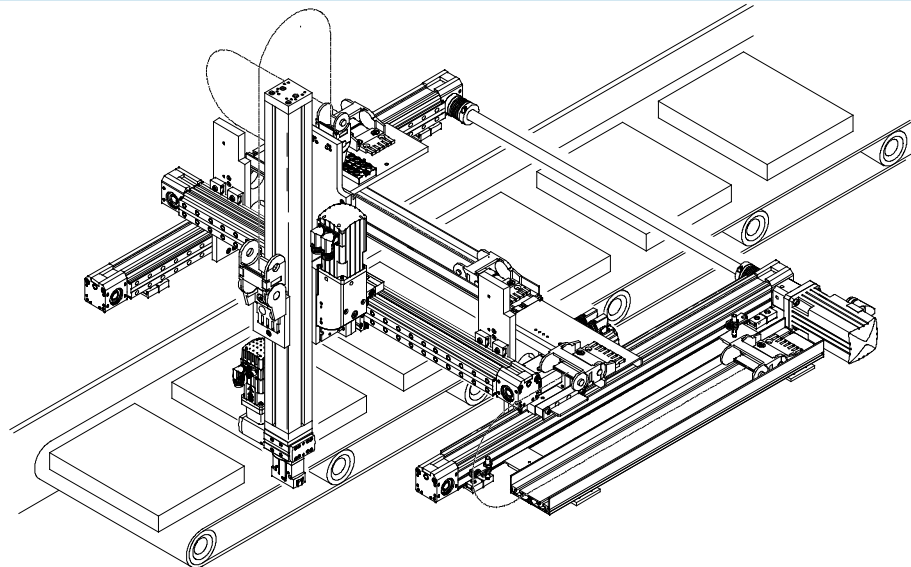

# Parallel kinematic robots EXPT, tripod

Key features

## The technology in detail

### Parallel kinematic robot

- 1 Mounting frame
- 2 Mounting bracket for toothed belt axis
- 3 Motor
- 4 Connection block
- 5 Rod pair
- 6 Interface housing
- 7 Angle kit → 31
- 8 Protective conduit → 31
- 9 Toothed belt axis
- 10 Tubing holder → 31
- 11 Front unit for attaching a gripper, etc. → 22

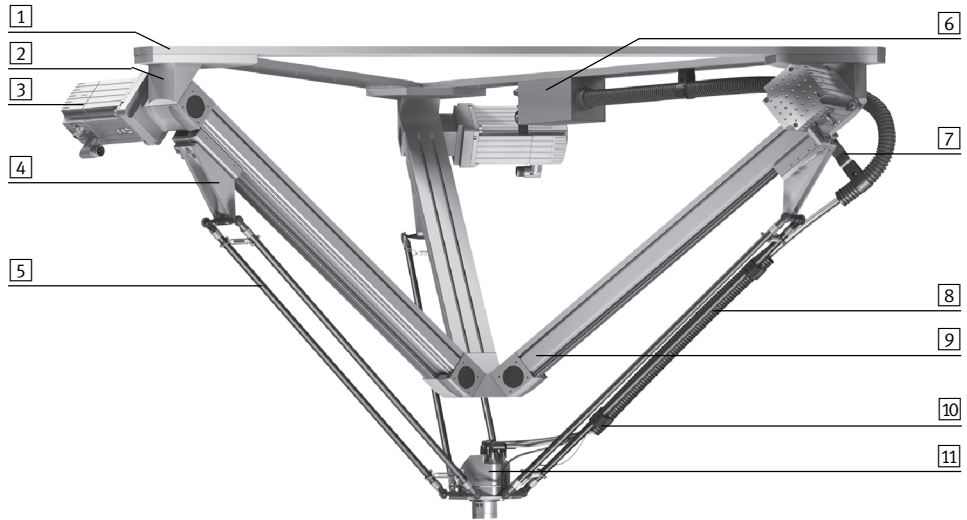

### Front unit

→ 22

The front unit can optionally be ordered via the modular product system.

It includes a geared motor that enables rotary movement (fourth axis) and is available in two sizes.

The front unit can also be chosen with or without rotary through-feed, for vacuum or excess pressure.

A range of grippers can be attached to it → 32.



### Installation type: Protected version (P8)

→ 28

A variant P8, where the axes are installed turned (slide on top), is available for the sizes 95 and 120. Abraded particles can form at the toothed belt; these particles therefore mostly collect in the axis and do not fall into the working space.

Standard

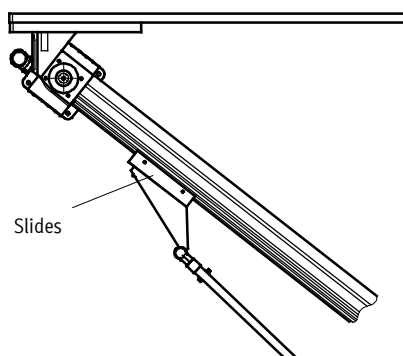

Slides

Protected version (P8)

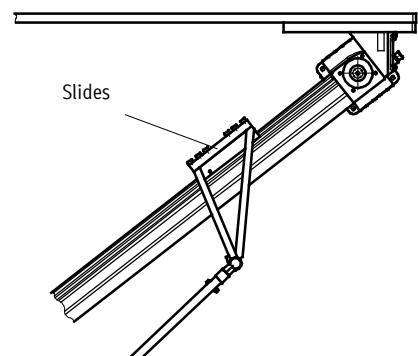

Slides

# Parallel kinematic robots EXPT, tripod

Key features

## Available working space

There are four sizes available with different working space diameters. In simplified terms, the possible working space can be described using the shape of a cylinder (→ drawing on the right). The more working space required, the smaller its diameter (→ graph below).

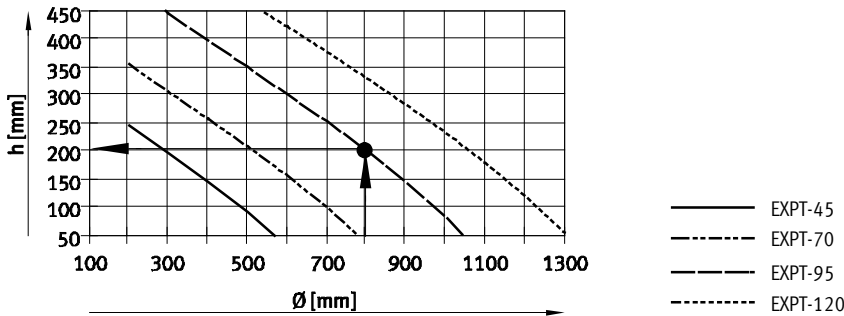
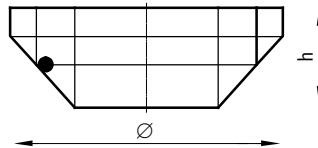
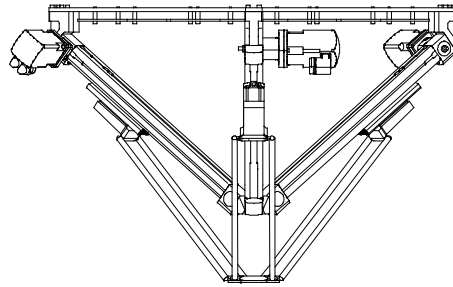

## Motor mounting variants

The attachment position of the motors can be individually configured via the modular product system (→ 28). The standard motor attachment position corresponds to code HHH (cf. illustration below). This means: A1/A2/A3 rear.

If a motor is to be attached on the front, a 'V' must be specified in the order code for the respective axis.

Code	Description
HHH	A1/A2/A3 rear
HHV	A3 front; A1/A2 rear
HVH	A2 front; A1/A3 rear
HVV	A2/A3 front; A1 rear
VHH	A1 front; A2/A3 rear
VHV	A1/A3 front; A2 rear
VVH	A1/A2 front; A3 rear
VVV	A1/A2/A3 front

The position of the interface housing depends on the position of the motor (V or H) on axis A1.

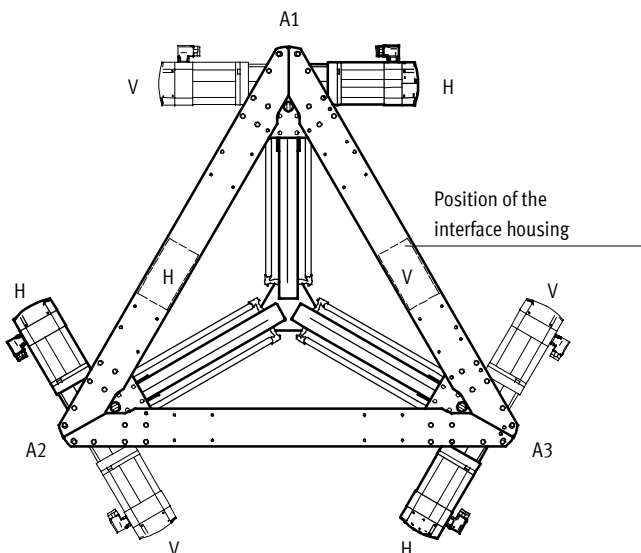

Coordinate system

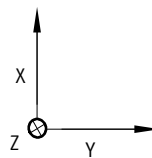

# Parallel kinematic robots EXPT, tripod

Key features

## Control solution CMCA

The control solution CMCA is suitable for the parallel kinematic robot EXPT. It is available in two variants:

- Mounting plate
- Mounting plate in the control cabinet housing

Can be ordered via the modular product system → 28 or separately  
→ Internet: cmca

The control solution includes the multi-axis controller CMXR and the motor controller CMMP required for activation. In addition, a safety circuit is also integrated, which together with the teach pendant CDSA represents the basic functionality.

The version with the control cabinet housing also features control elements and fans in the door. The control solution CMCA is pre-programmed and already tested together with the relevant parallel kinematic robot.

### Mounting plate

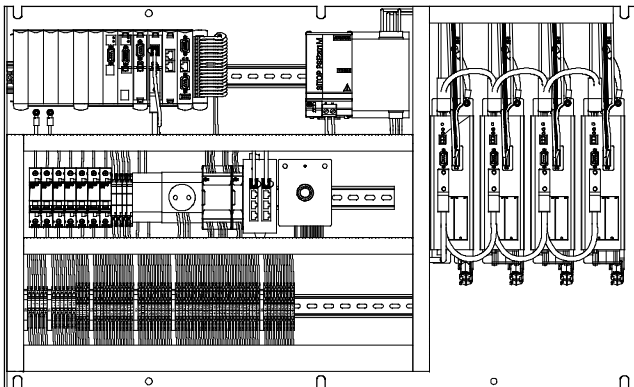

### Mounting plate in the control cabinet housing

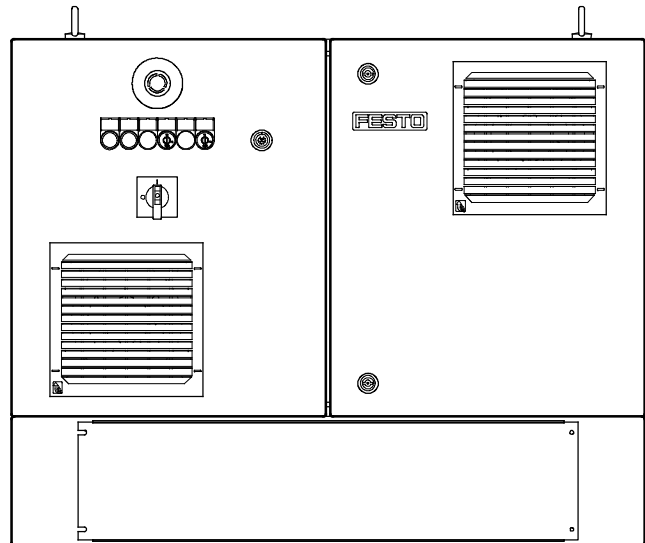

## Relationship between the order code of the parallel kinematic robot EXPT and the control solution CMCA

Depending on the configured parallel kinematic robot EXPT

- with or without front unit
- variant of the control solution
- controller type

the order codes for the control solution CMCA are as follows:

Allocation table	
Parallel kinematic robot EXPT	Control solution CMCA
<b>For mounting plate</b>	
EXPT-...-T0-...-C-C1-...	CMCA-K1-C1-A4-C-S1
EXPT-...-T0-...-C-C2-...	CMCA-K1-C2-A4-C-S1
EXPT-...-T1 to T4-...-C-C1-...	CMCA-K1-C1-A5-C-S1
EXPT-...-T1 to T4-...-C-C2-...	CMCA-K1-C2-A5-C-S1
<b>For mounting plate in the control cabinet housing</b>	
EXPT-...-T0-...-CC-C1-...	CMCA-K1-C1-A4-CC-S1
EXPT-...-T0-...-CC-C2-...	CMCA-K1-C2-A4-CC-S1
EXPT-...-T1 to T4-...-CC-C1-...	CMCA-K1-C1-A5-CC-S1
EXPT-...-T1 to T4-...-CC-C2-...	CMCA-K1-C2-A5-CC-S1

# Parallel kinematic robots EXPT, tripod

Type codes

		EXPT	-	70	-	E1	-	T2	-	HHH	-	
<b>Type</b>												
EXPT	Parallel kinematic robot											
<b>Working space [mm]</b>												
45	∅ 450, H100											
70	∅ 700, H100											
95	∅ 950, H100											
120	∅ 1,200; H100											
<b>Drive</b>												
E1	DGE-25											
E4	EGC-80											
<b>Attachment components</b>												
T0	Without rotary drive											
T1	Rotary drive, size 8											
T2	Rotary drive, size 8 with pneumatic rotary through-feed											
T3	Rotary drive, size 11											
T4	Rotary drive, size 11 with pneumatic rotary through-feed											
<b>Motor attachment position</b>												
HHH	A1/A2/A3 rear											
HHV	A3 front; A1/A2 rear											
HVH	A2 front; A1/A3 rear											
HVV	A2/A3 front; A1 rear											
VHH	A1 front; A2/A3 rear											
VHV	A1/A3 front; A2 rear											
VVH	A1/A2 front; A3 rear											
VVV	A1/A2/A3 front											
<b>Particle protection</b>												
-	Standard											
P8	Protected version											

# Parallel kinematic robots EXPT, tripod

Type codes

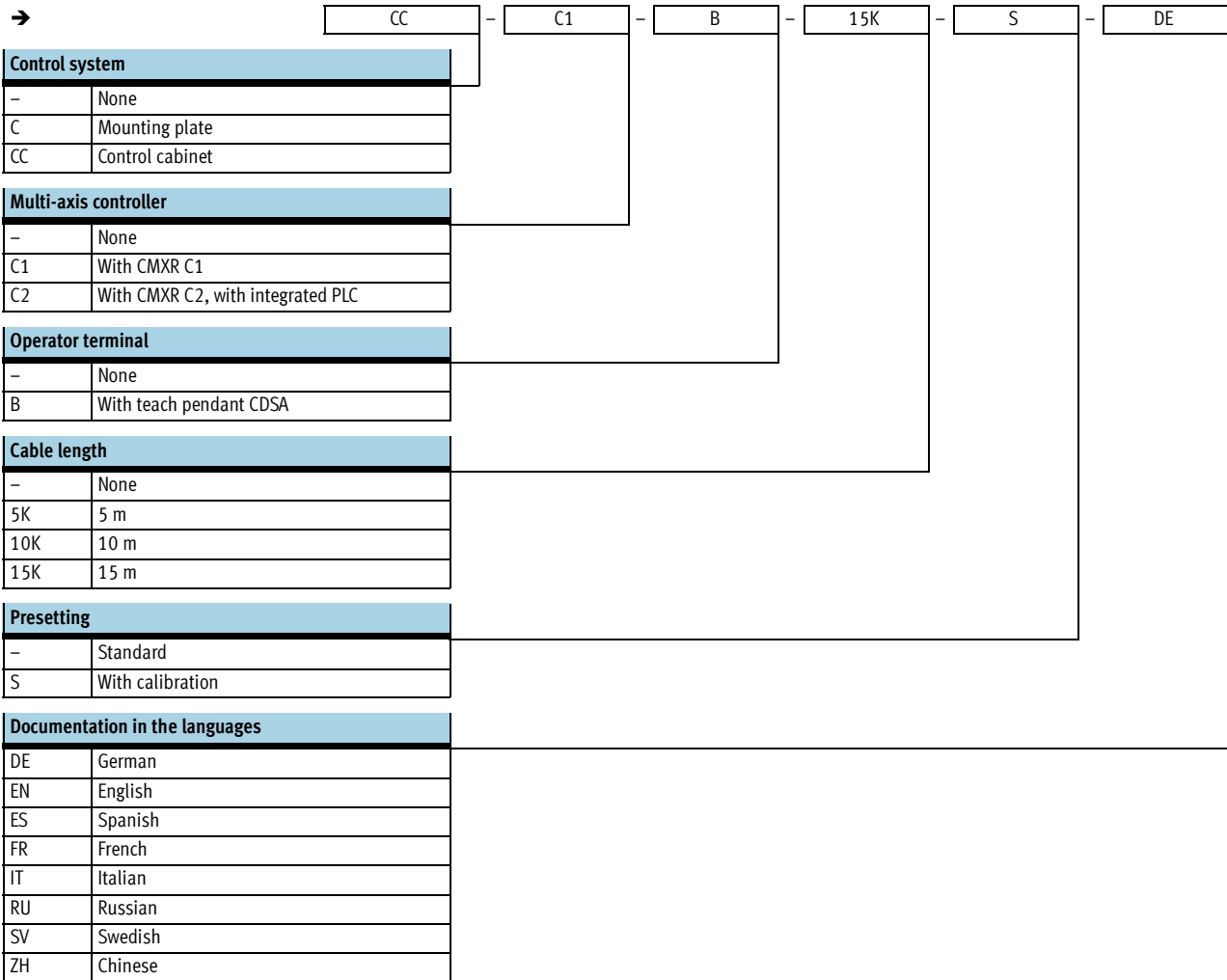

# Parallel kinematic robots EXPT, tripod

Peripherals overview

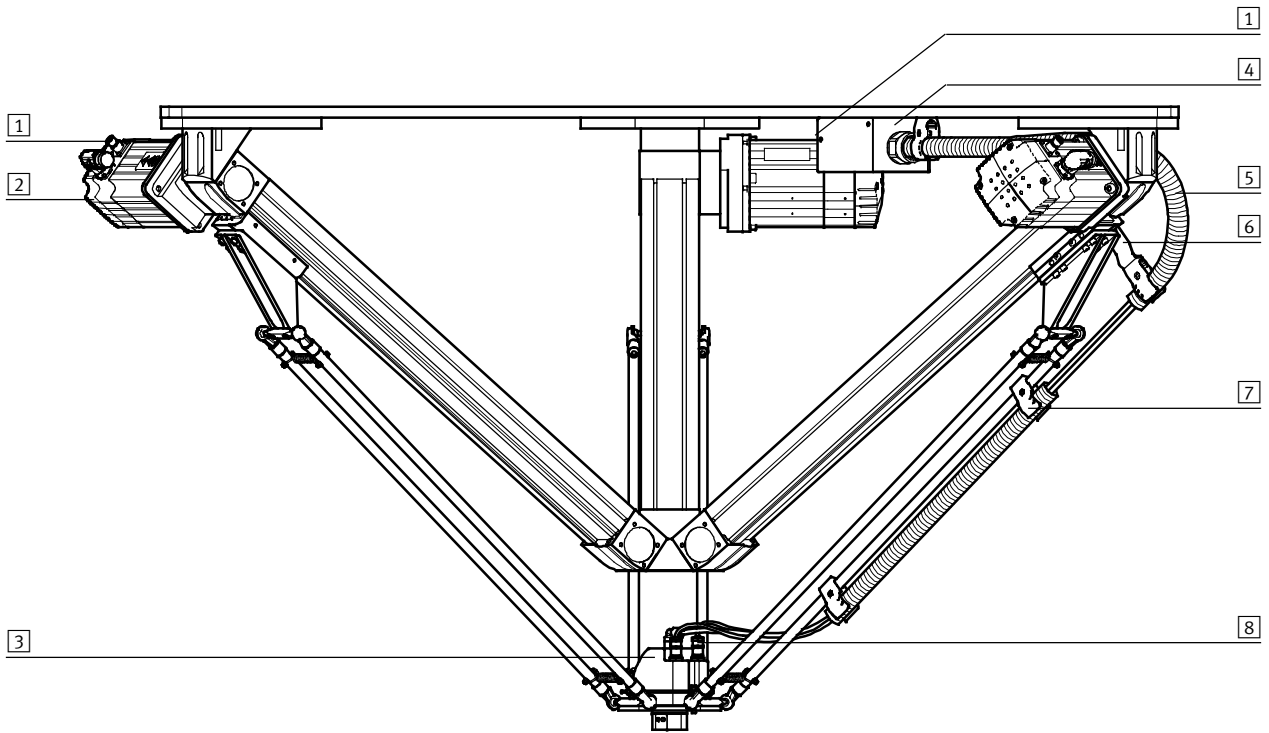



## Parallel kinematic robots EXPT, tripod

Peripherals overview

Attachments and accessories		
Type	Description	→ Page/Internet
1 Connecting cable 5K, 10K, 15K	All required connecting cables/tubing are included in the delivery as loose parts. The required cable length can be selected in the modular product system (none, 5 m, 10 m or 15 m)	30
2 Servo motor HHH, HHV, ...	The attachment position of the motors can be defined via the modular product system (HHH ... VVV). No homing required thanks to a multi-turn rotary encoder	-
3 Front unit T0, T1, T2, ...	Choose from: <ul style="list-style-type: none"> <li>• Front unit without rotary drive (T0)</li> <li>• Front unit with rotary drive (T1 to T4)</li> </ul>	-
4 Interface housing	Serves as the interface between the parallel kinematic robot and the control cabinet, to supply the front unit	-
5 Protective conduit MKG	Is pre-assembled for all variants (T0 to T4), on axis A1	31
6 Angle kit EAHM-E10	Is pre-assembled for all variants (T0 to T4), on axis A1. If required, further angle kits can be ordered as accessories	31
7 Tubing holder EAHM-E10-TH	Is pre-assembled for all variants (T0 to T4), on axis A1. If required, further tubing holders can be ordered as accessories	31
8 Front unit installation	The lines to supply the front unit are already installed between the front unit and the interface housing	-

# Parallel kinematic robots EXPT, tripod

Technical data

 Size  
45, 70, 95, 120

 [www.festo.com](http://www.festo.com)



General technical data					
Size		45	70	95	120
Design		Parallel kinematic robot			
Motor type		Servo motor			
Mounting position		Horizontal			
Working space					
Nominal diameter	[mm]	450	700	950	1,200
Nominal height	[mm]	100	100	100	100
Max. acceleration <sup>1)</sup>	[m/s <sup>2</sup> ]	110			
Max. speed <sup>1)</sup>	[m/s]	7			
Max. pick rate <sup>1)2)</sup>	[picks/min]	150			
Repetition accuracy	[mm]	±0.1			
Positioning accuracy <sup>3)</sup>	[mm]	±0.5			
Track precision <sup>3)4)</sup>	[mm]	±0.5			
Effective load <sup>5)</sup>					
With min. dynamic response	[kg]	5			
With max. dynamic response	[kg]	1			
Base weight	[kg]	45	47.5	61.5	66

- 1) When used in combination with motor controller CMMP-AS-C5-3A and multi-axis controller CMXR.
- 2) In the 12° cycle.
- 3) Only with calibrated system (order code S).
- 4) At a speed of ≤0.3 m/s.
- 5) Total of the load mass and the accessories mounted on the front unit.

Max. process force in Z direction					
Size		45	70	95	120
With working space diameter	[mm]	0	0	0	0
Process force	[N]	1,300	1,000	1,000	850
With working space diameter <sup>6)</sup>	[mm]	112.5	175	237.5	300
Process force	[N]	1,000	750	750	750

- 6) The specified values correspond to 25% of the nominal diameter.

Operating and environmental conditions		
Ambient temperature	[°C]	0 ... +40
Storage temperature	[°C]	-10 ... +60
Operating pressure for rod loss detection	[bar]	2 ... 8
Duty cycle <sup>7)</sup>	[%]	100
Corrosion resistance class CRC <sup>8)</sup>		2

- 7) When used in combination with motor controller CMMP-AS-C5-3A and multi-axis controller CMXR.
- 8) Corrosion resistance class 2 according to Festo standard 940 070  
Components subject to moderate corrosion stress. Externally visible parts with primarily decorative surface requirements which are in direct contact with a normal industrial environment or media such as coolants or lubricating agents.

# Parallel kinematic robots EXPT, tripod

Technical data

FESTO

## Materials

Sectional view

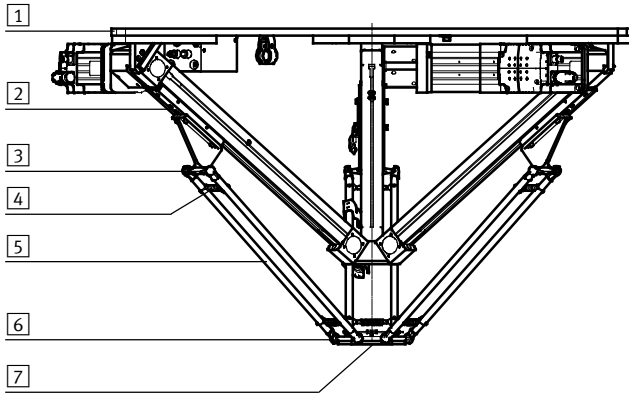

### Parallel kinematic robot

1	Mounting frame	Wrought aluminium alloy
2	Toothed belt axis DGE/EGC	→ Internet: dge, egc
3	Ball stud	Wrought aluminium alloy
4	Tension spring	High-alloy stainless steel
5	Rod pair	Plastic, carbon-fibre reinforced
6	Ball cup	Polyamide
	Ball	Ceramic
7	Front unit	Wrought aluminium alloy
-	Note on materials	Contains PWIS (paint-wetting impairment substances) Free of copper and PTFE

## Rod loss detection

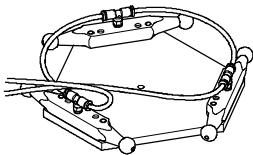

The rod loss detection feature detects detached rods and initiates an emergency stop.

It is realised via permanent compressed air monitoring (pressure switch integrated in the frame of the interface housing)

This is done by pressurising the ball cup connections of the front unit with compressed air at 2 bar (rel.).

Connections on the interface housing:

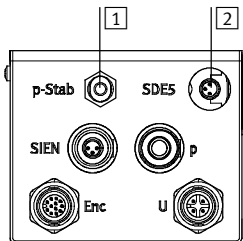

1 Compressed air supply for rod loss detection.  
The compressed air is adjusted to 2 bar in the interface housing.

2 Pressure sensor for monitoring rod loss detection.  
Connecting cable → 30

## Pick rate as a function of effective load

The characteristic values for dynamic response are determined in so-called 12" cycles. The graph below shows the maximum number of possible cycles as a function of effective load. It is based on an accuracy of ±0.5 mm.

One 12" cycle means:

1. To the gripping position
2. To the start position
3. To the transfer position
4. To the set down position
5. To the transfer position
6. To the start position

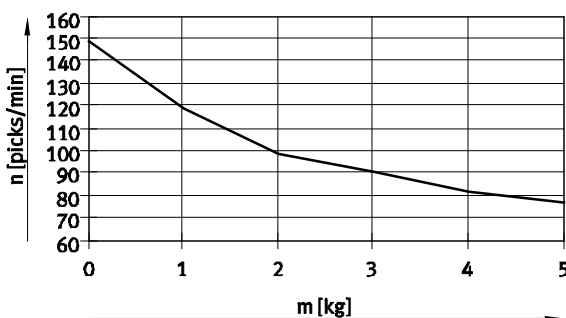
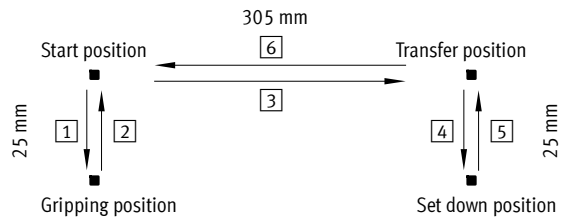

n= Cycles per minute  
m= Effective load

# Parallel kinematic robots EXPT, tripod

Technical data

Max. acceleration  $a$  as a function of position in the working space  $R$  and distance  $l$  from the centre of gravity of the effective load  $m$  to the front unit

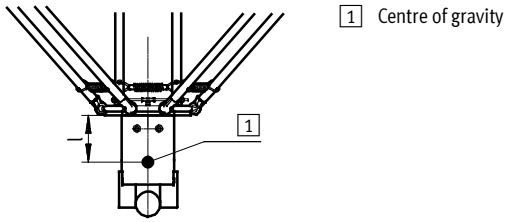

## EXPT-45

Effective load of 0.1 kg

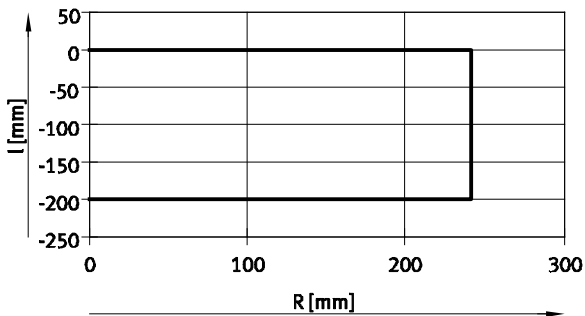

—  $a = 0 \dots 100 \text{ m/s}^2$

Effective load of 0.5 kg

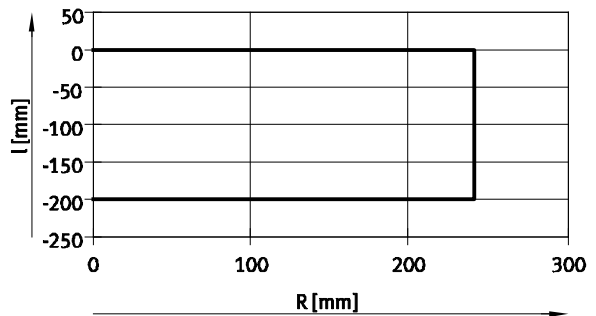

—  $a = 0 \dots 100 \text{ m/s}^2$

Effective load of 1 kg

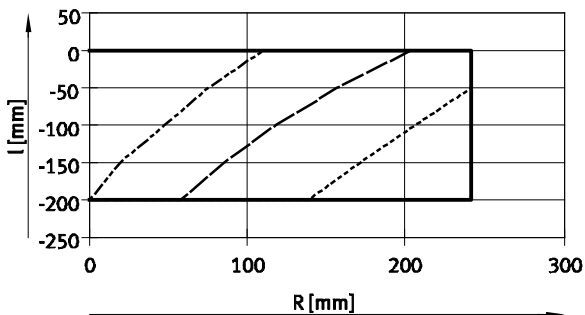

—  $a = 0 \dots 70 \text{ m/s}^2$   
 - - -  $a = 100 \text{ m/s}^2$   
 - - -  $a = 90 \text{ m/s}^2$   
 - - -  $a = 80 \text{ m/s}^2$

Effective load of 1.5 kg

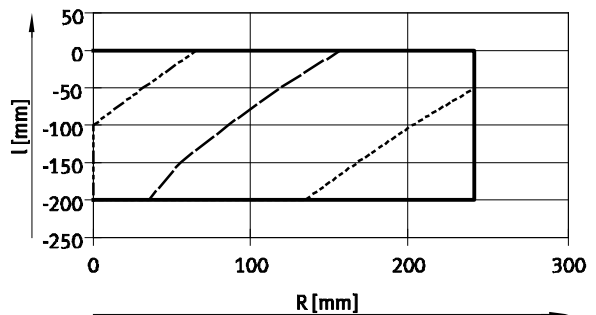

—  $a = 0 \dots 50 \text{ m/s}^2$   
 - - -  $a = 80 \text{ m/s}^2$   
 - - -  $a = 70 \text{ m/s}^2$   
 - - -  $a = 60 \text{ m/s}^2$

# Parallel kinematic robots EXPT, tripod

Technical data

Max. acceleration  $a$  as a function of position in the working space  $R$  and distance  $l$  from the centre of gravity of the effective load  $m$  to the front unit

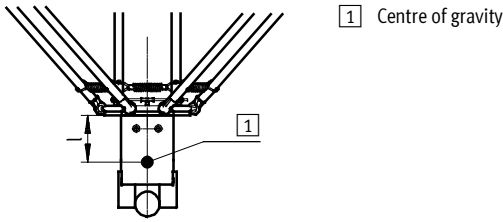

## EXPT-45

Effective load of 2 kg

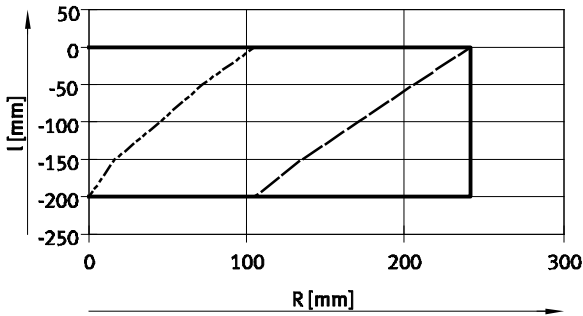

—  $a = 0 \dots 40 \text{ m/s}^2$   
 - - -  $a = 60 \text{ m/s}^2$   
 - · -  $a = 50 \text{ m/s}^2$

Effective load of 3 kg

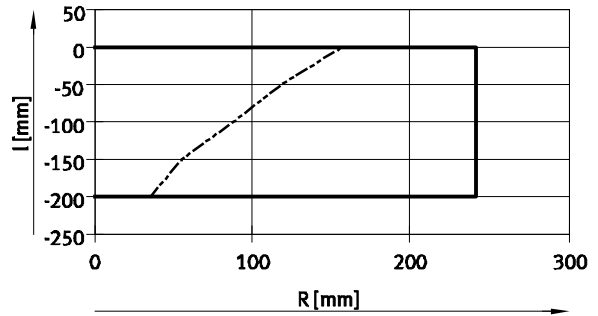

—  $a = 0 \dots 30 \text{ m/s}^2$   
 - - -  $a = 40 \text{ m/s}^2$

Effective load of 4 kg

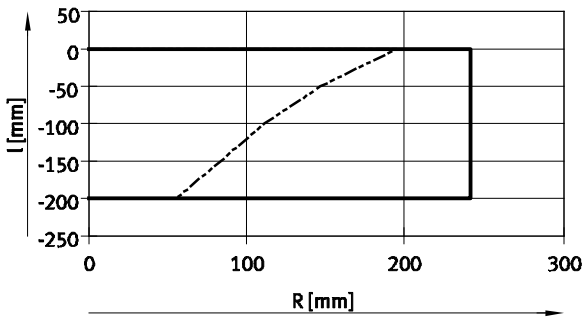

—  $a = 0 \dots 20 \text{ m/s}^2$   
 - - -  $a = 30 \text{ m/s}^2$

Effective load of 5 kg

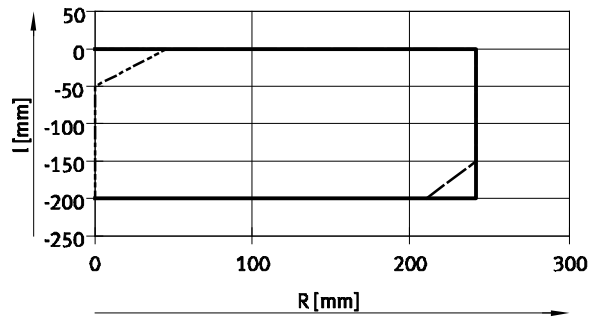

—  $a = 0 \dots 10 \text{ m/s}^2$   
 - - -  $a = 30 \text{ m/s}^2$   
 - · -  $a = 20 \text{ m/s}^2$

# Parallel kinematic robots EXPT, tripod

Technical data

Max. acceleration  $a$  as a function of position in the working space  $R$  and distance  $l$  from the centre of gravity of the effective load  $m$  to the front unit

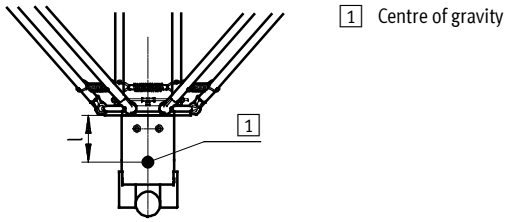

## EXPT-70

Effective load of 0.1 kg

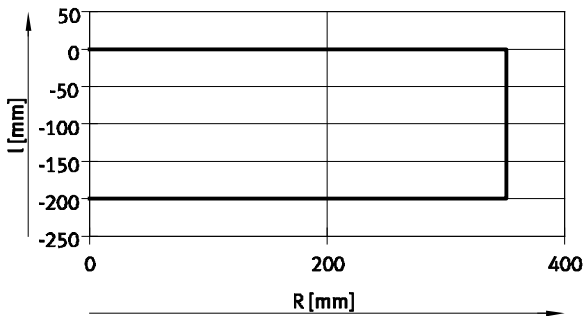

—  $a = 0 \dots 100 \text{ m/s}^2$

Effective load of 0.5 kg

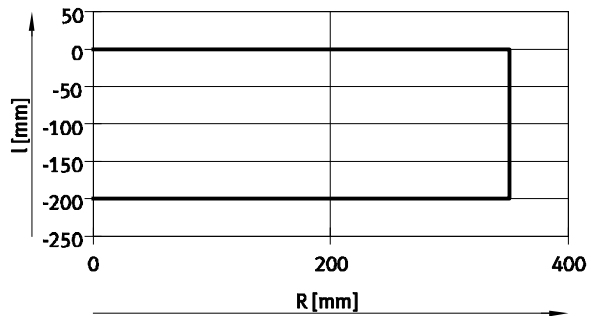

—  $a = 0 \dots 100 \text{ m/s}^2$

Effective load of 1 kg

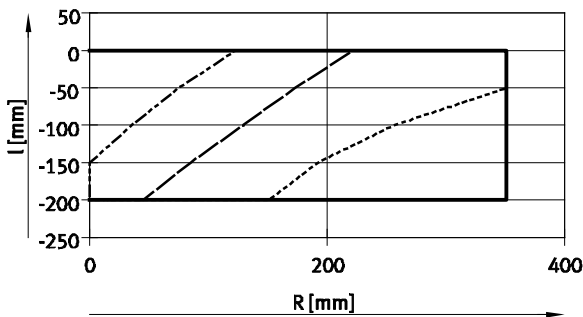

—  $a = 0 \dots 70 \text{ m/s}^2$   
 - - -  $a = 100 \text{ m/s}^2$   
 - - -  $a = 90 \text{ m/s}^2$   
 - - -  $a = 80 \text{ m/s}^2$

Effective load of 1.5 kg

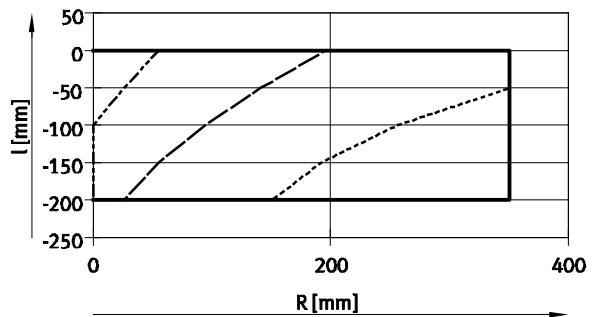

—  $a = 0 \dots 50 \text{ m/s}^2$   
 - - -  $a = 80 \text{ m/s}^2$   
 - - -  $a = 70 \text{ m/s}^2$   
 - - -  $a = 60 \text{ m/s}^2$

# Parallel kinematic robots EXPT, tripod

Technical data

Max. acceleration  $a$  as a function of position in the working space  $R$  and distance  $l$  from the centre of gravity of the effective load  $m$  to the front unit

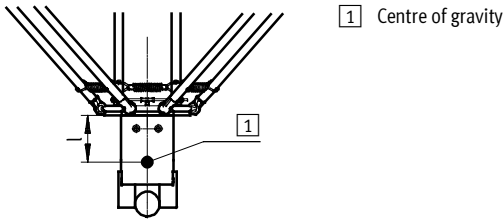

## EXPT-70

Effective load of 2 kg

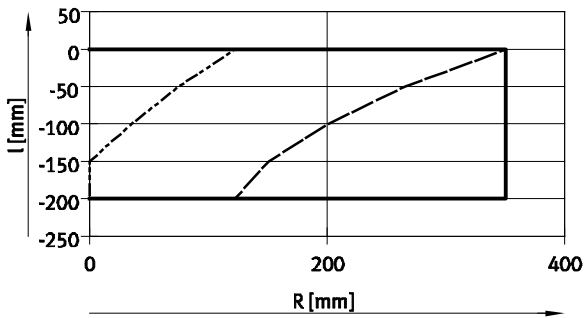

—  $a = 0 \dots 40 \text{ m/s}^2$   
 - - -  $a = 60 \text{ m/s}^2$   
 - · -  $a = 50 \text{ m/s}^2$

Effective load of 3 kg

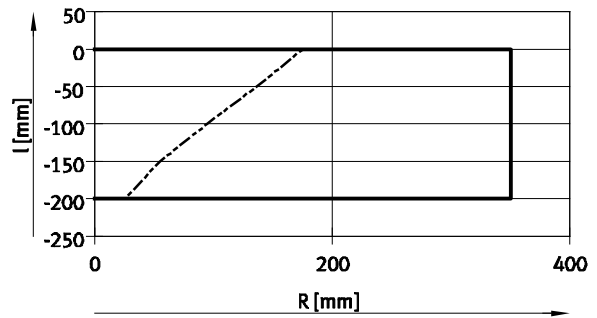

—  $a = 0 \dots 30 \text{ m/s}^2$   
 - - -  $a = 40 \text{ m/s}^2$

Effective load of 4 kg

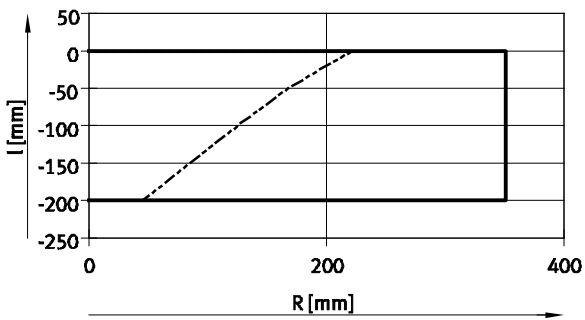

—  $a = 0 \dots 20 \text{ m/s}^2$   
 - - -  $a = 30 \text{ m/s}^2$

Effective load of 5 kg

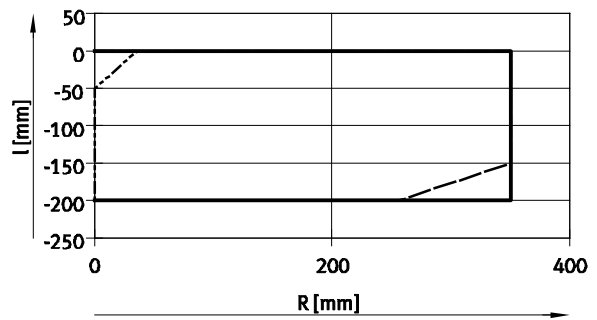

—  $a = 0 \dots 10 \text{ m/s}^2$   
 - - -  $a = 30 \text{ m/s}^2$   
 - · -  $a = 20 \text{ m/s}^2$

# Parallel kinematic robots EXPT, tripod

Technical data

Max. acceleration  $a$  as a function of position in the working space  $R$  and distance  $l$  from the centre of gravity of the effective load  $m$  to the front unit

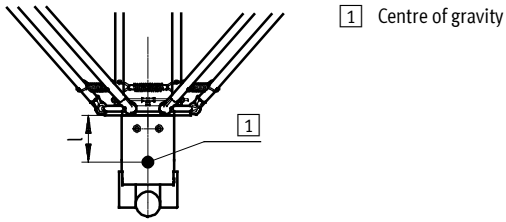

## EXPT-95

Effective load of 0.1 kg

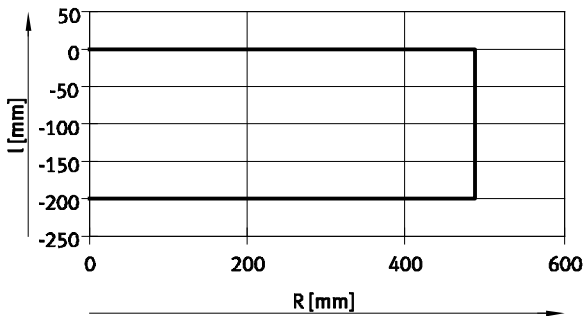

—  $a = 0 \dots 100 \text{ m/s}^2$

Effective load of 0.5 kg

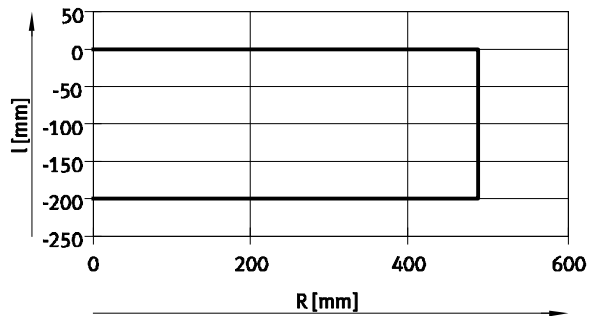

—  $a = 0 \dots 100 \text{ m/s}^2$

Effective load of 1 kg

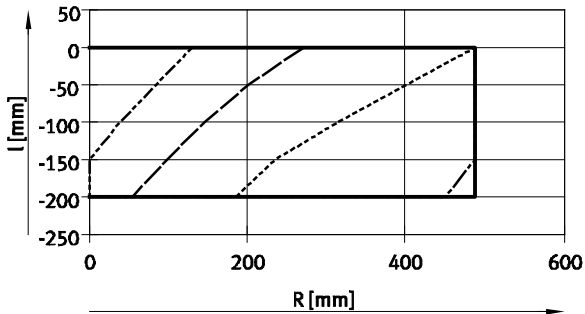

—  $a = 0 \dots 60 \text{ m/s}^2$   
 - - -  $a = 100 \text{ m/s}^2$   
 - - -  $a = 90 \text{ m/s}^2$   
 - - -  $a = 80 \text{ m/s}^2$   
 - - -  $a = 70 \text{ m/s}^2$

Effective load of 1.5 kg

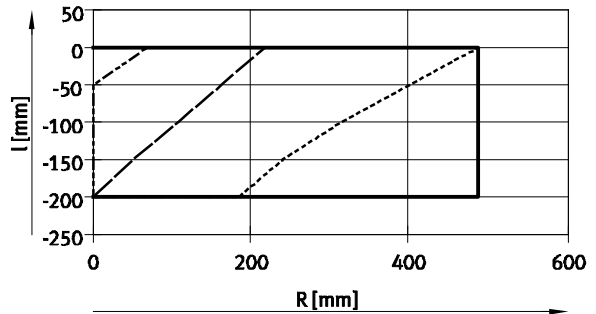

—  $a = 0 \dots 50 \text{ m/s}^2$   
 - - -  $a = 80 \text{ m/s}^2$   
 - - -  $a = 70 \text{ m/s}^2$   
 - - -  $a = 60 \text{ m/s}^2$



# Parallel kinematic robots EXPT, tripod

Technical data

Max. acceleration  $a$  as a function of position in the working space  $R$  and distance  $l$  from the centre of gravity of the effective load  $m$  to the front unit

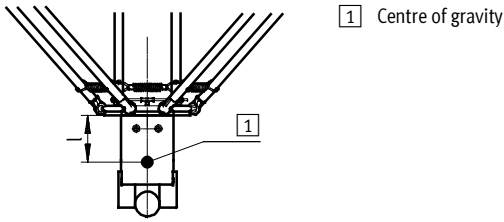

## EXPT-95

Effective load of 2 kg

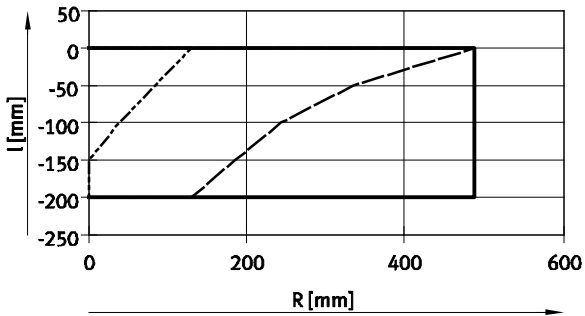

—  $a = 0 \dots 40$  m/s<sup>2</sup>  
 - - -  $a = 60$  m/s<sup>2</sup>  
 - · -  $a = 50$  m/s<sup>2</sup>

Effective load of 3 kg

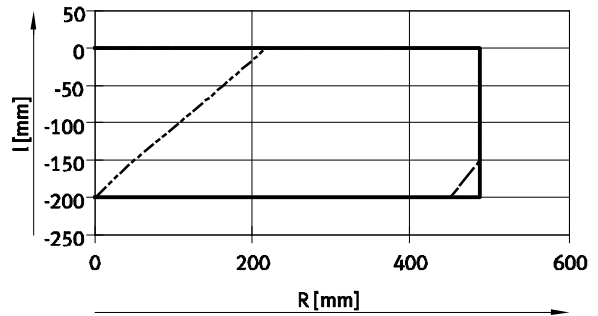

—  $a = 0 \dots 20$  m/s<sup>2</sup>  
 - - -  $a = 40$  m/s<sup>2</sup>  
 - · -  $a = 30$  m/s<sup>2</sup>

Effective load of 4 kg

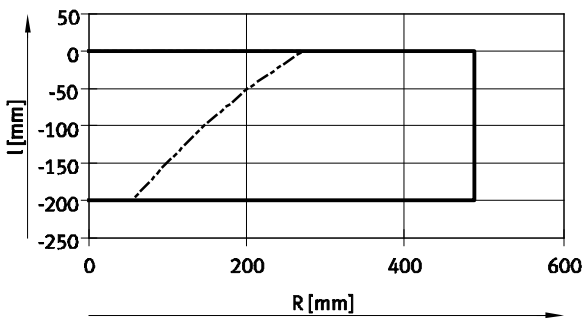

—  $a = 0 \dots 20$  m/s<sup>2</sup>  
 - - -  $a = 30$  m/s<sup>2</sup>

Effective load of 5 kg

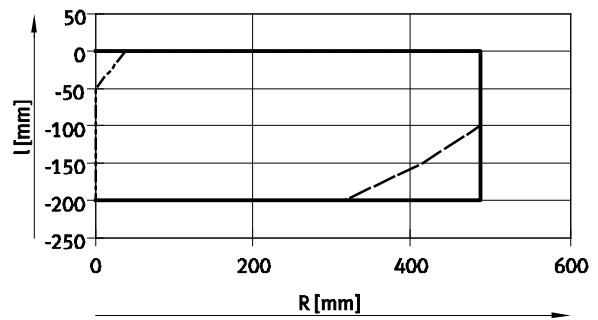

—  $a = 0 \dots 10$  m/s<sup>2</sup>  
 - - -  $a = 30$  m/s<sup>2</sup>  
 - · -  $a = 20$  m/s<sup>2</sup>

# Parallel kinematic robots EXPT, tripod

Technical data

Max. acceleration  $a$  as a function of position in the working space  $R$  and distance  $l$  from the centre of gravity of the effective load  $m$  to the front unit

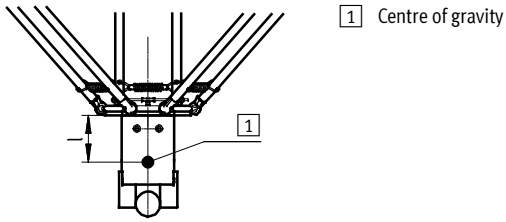

## EXPT-120

Effective load of 0.1 kg

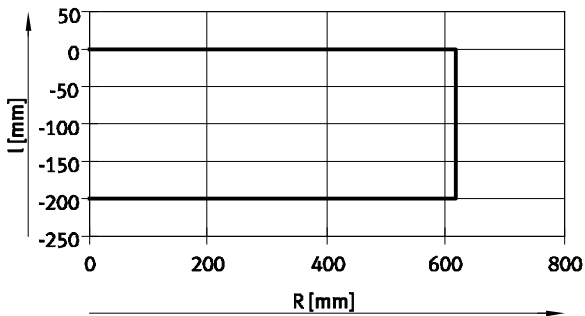

—  $a = 0 \dots 100 \text{ m/s}^2$

Effective load of 0.5 kg

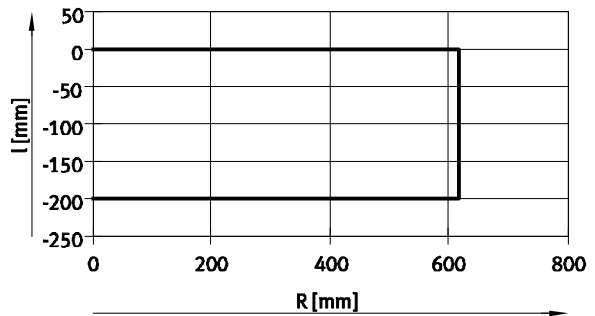

—  $a = 0 \dots 100 \text{ m/s}^2$

Effective load of 1 kg

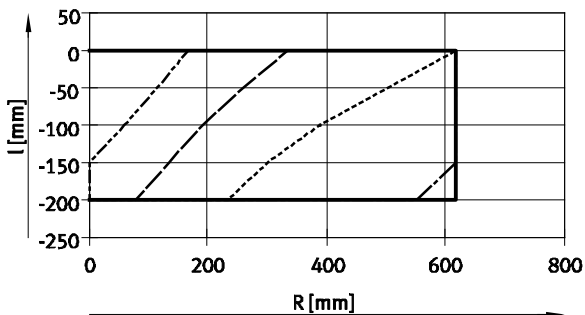

—  $a = 0 \dots 60 \text{ m/s}^2$   
 - - -  $a = 100 \text{ m/s}^2$   
 - - -  $a = 90 \text{ m/s}^2$   
 - - -  $a = 80 \text{ m/s}^2$   
 - - -  $a = 70 \text{ m/s}^2$

Effective load of 1.5 kg

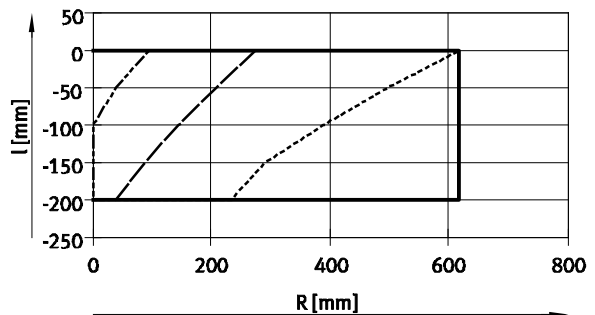

—  $a = 0 \dots 50 \text{ m/s}^2$   
 - - -  $a = 80 \text{ m/s}^2$   
 - - -  $a = 70 \text{ m/s}^2$   
 - - -  $a = 60 \text{ m/s}^2$

# Parallel kinematic robots EXPT, tripod

Technical data

Max. acceleration  $a$  as a function of position in the working space  $R$  and distance  $l$  from the centre of gravity of the effective load  $m$  to the front unit

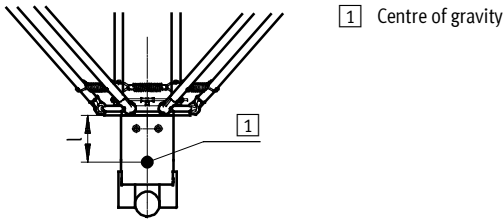

## EXPT-120

Effective load of 2 kg

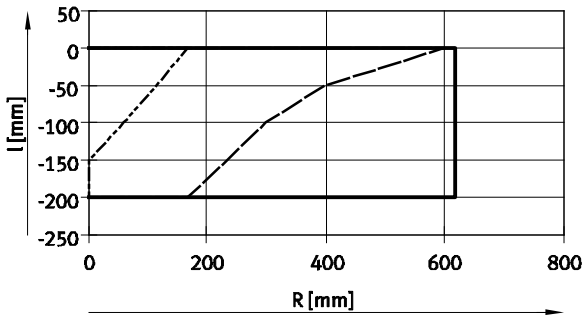

—  $a = 0 \dots 40 \text{ m/s}^2$   
 - - -  $a = 60 \text{ m/s}^2$   
 - · -  $a = 50 \text{ m/s}^2$

Effective load of 3 kg

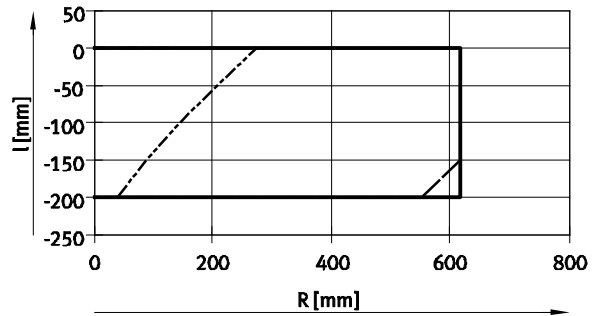

—  $a = 0 \dots 20 \text{ m/s}^2$   
 - - -  $a = 40 \text{ m/s}^2$   
 - · -  $a = 30 \text{ m/s}^2$

Effective load of 4 kg

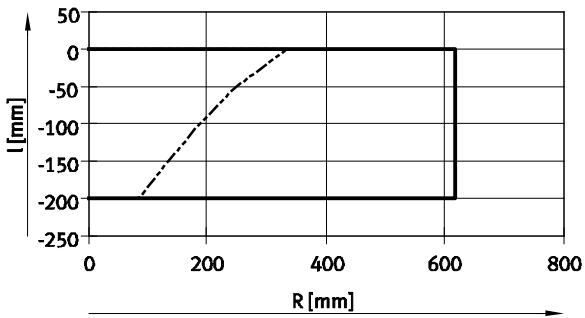

—  $a = 0 \dots 20 \text{ m/s}^2$   
 - - -  $a = 30 \text{ m/s}^2$

Effective load of 5 kg

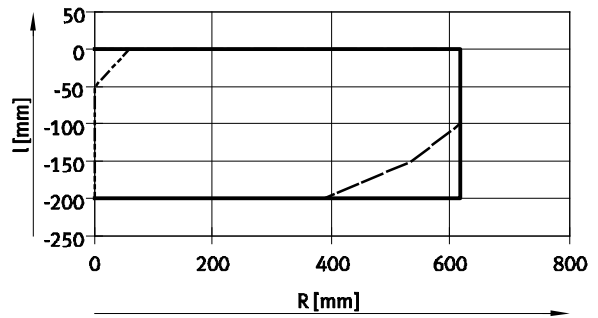

—  $a = 0 \dots 10 \text{ m/s}^2$   
 - - -  $a = 30 \text{ m/s}^2$   
 - · -  $a = 20 \text{ m/s}^2$

# Parallel kinematic robots EXPT, tripod

Technical data

## Requirements for the frame

The positioning and path accuracy depends to a large extent on the frame design.

The following influences must therefore be taken into consideration:

- Frame rigidity
- Frame mass
- Parallel kinematic robot mass

- Start-up frequency caused by dynamic operation of the parallel kinematic robot
  - Cycles per minute
  - Dynamic settings for acceleration and jerk

Maximum forces occur if two axes accelerate in the opposite direction to the third and result in horizontal movement of the effective load. The frame must be designed so that the maximum forces that can occur as a result of the parallel kinematics can be absorbed with the necessary degree of certainty.

The guide value for the first natural frequency is specified for the complete system of at least 16 Hz.

At maximum dynamic response for the axes, the following forces act on the corner bracket and therefore on the mounting in the frame.

Size		45	70	95	120
Vertical force	[N]	±250	±290	±325	±475
Horizontal force	[N]	±145	±150	±200	±215

## Mounting options on the frame

The kinematic structure must always be mounted in the area of the corner bracket of the mounting frame. Ensure that the corner bracket area has a torsionally rigid, flat bearing surface.

The bearing surface must meet the following minimum requirements in order to achieve the positioning accuracy:

- Flatness = 0.05 mm
- Parallelism = 0.5 mm

Since the distance between slots is 40 mm in the 80x80 profile, the holes in the corner brackets are positioned so that the profile can be mounted in various positions.

Since axis homing settings are lost when the motor is dismounted, it is recommended to use mounting holes that do not require the motor to be removed. The holes 1 are not accessible, depending on the attachment position of the motor.

### Direct mounting via screws

#### Screws M8x...

Via at least 4 screws (M8) per corner bracket directly on the frame. These 4 screws should be placed as far apart

as possible to ensure a torsionally rigid connection.

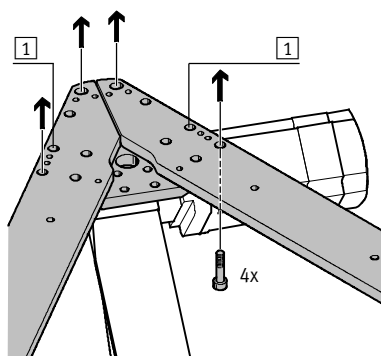

#### Screws M20x...

Via 1 screw (M20) per corner bracket directly on the frame. There is a central hole for this purpose on every corner.

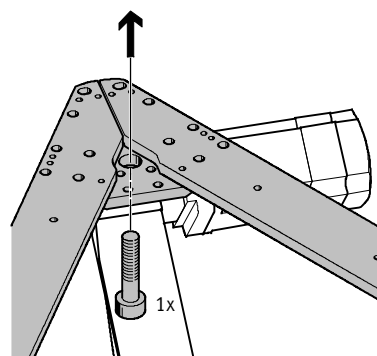

# Parallel kinematic robots EXPT, tripod

Technical data

## Mounting options on the frame

Mounting via slot nuts – parallel to the mounting frame

- 1 Profile (e.g. HMBS-80/80)
- 2 Slot nut (e.g. NST-HMV-8-2-M8)
- 3 Screws (e.g. M8x35)

### Example 1

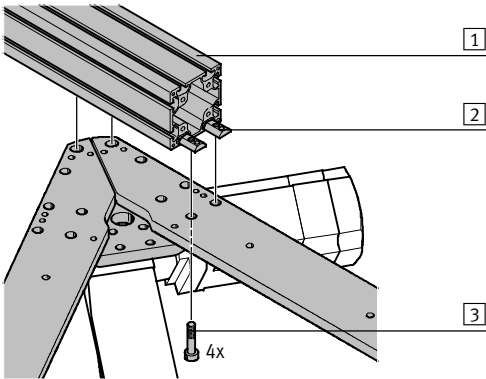

### Example 2

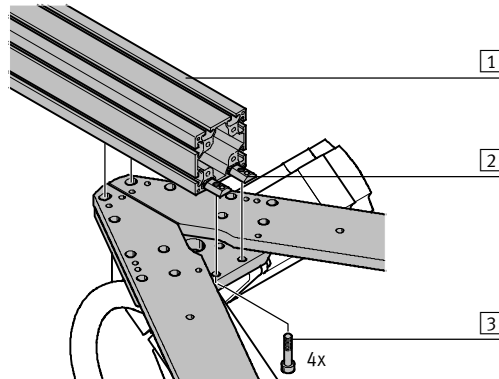

Mounting via slot nuts – at right angles to the mounting frame

- 1 Profile (e.g. HMBS-80/80)
- 2 Slot nut (e.g. NST-HMV-8-2-M8)
- 3 Screws (e.g. M8x35)
- 4 Bracket

The additional angle brackets in the following examples are required in order to increase the torsional rigidity and the bearing surface.

### Example 1

Profile mounting

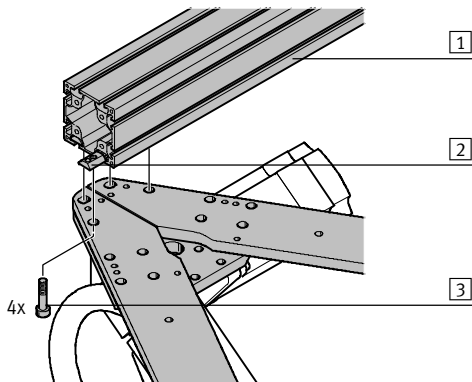

Angle bracket mounting

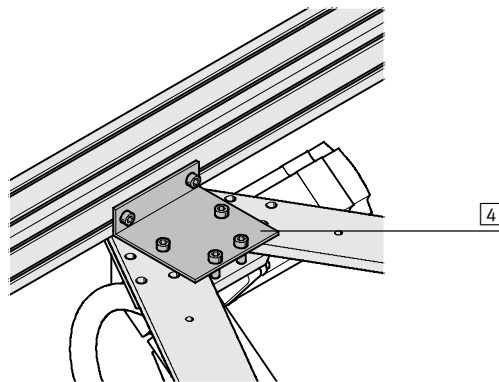

### Example 2

Profile mounting

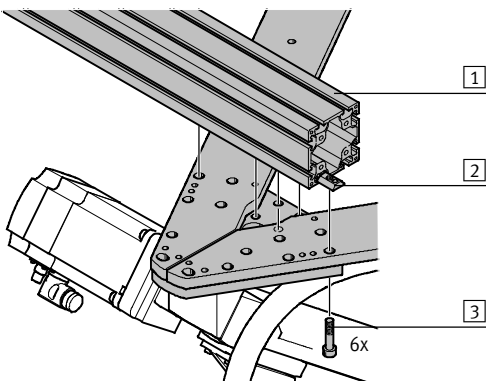

Angle bracket mounting

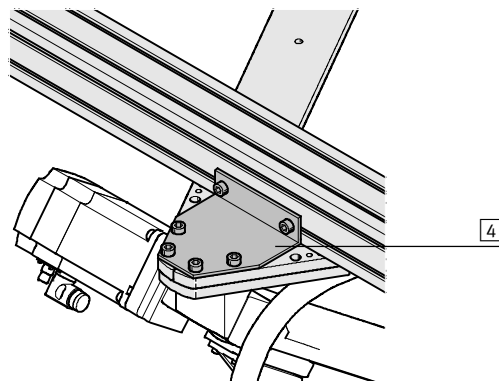

# Parallel kinematic robots EXPT, tripod

Technical data

**Technical data – Front unit**

EXPT-...-T...



Mechanical data				
Type	EXPT-...-			
	T1	T2	T3	T4
Design	Electromechanical rotary module			
	-	With rotary through-feed	-	With rotary through-feed
Motor type	Servo motor			
Size	8	8	11	11
Rotation angle	Infinite			
Pneumatic connection	-	G1/8	-	G1/8
Nominal size [mm]	-	4	-	4
Standard nominal flow rate [l/min]	-	350	-	350
Gear ratio	30:1			
Repetition accuracy [°]	±0.01			
Max. output speed [rpm]	200			
Nominal torque [Nm]	0.75	0.75	1.8	1.8
Peak torque [Nm]	1.8	1.8	4.5	4.5
Max. axial force [N]	200	200	300	300
Max. pull-out torque, static [Nm]	15	15	40	40
Perm. mass moment of inertia of load [kgm <sup>2</sup> ]	0.0026	0.0026	0.006	0.006
Mounting position	Any			
Load mass for EXPT [g]	640	690	850	900

Electrical data				
Type	EXPT-...-			
	T1	T2	T3	T4
Nominal voltage [V AC]	230			
Nominal current [A]	0.31	0.31	0.74	0.74
Peak current [A]	0.61	0.61	1.5	1.5
Rated output [W]	9.2	9.2	22.1	22.1
Duty cycle [%]	100			
Measuring system <sup>1)</sup>	Encoder			

1) Homing required

Operating and environmental conditions				
Type	EXPT-...-			
	T1	T2	T3	T4
Operating pressure [bar]	-	-0.9 ... +10	-	-0.9 ... +10
Ambient temperature [°C]	0 ... 40			
Protection	IP40			
Note on materials	RoHS-compliant			
Corrosion resistance class CRC <sup>1)</sup>	2			

1) Corrosion resistance class 2 according to Festo standard 940 070  
 Components subject to moderate corrosion stress. Externally visible parts with primarily decorative surface requirements which are in direct contact with a normal industrial environment or media such as coolants or lubricating agents.

# Parallel kinematic robots EXPT, tripod

Technical data

FESTO

## Connections on the interface housing

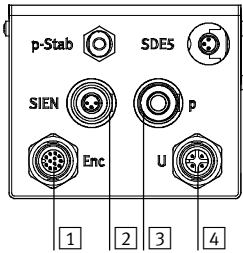

Connection for:

- 1 Encoder cable → 30
- 2 Sensor for rotary motion → 30
- 3 Supply port for pneumatic rotary through-feed
- 4 Motor cable → 30

## Dimensions

Download CAD data → [www.festo.com](http://www.festo.com)

Front unit

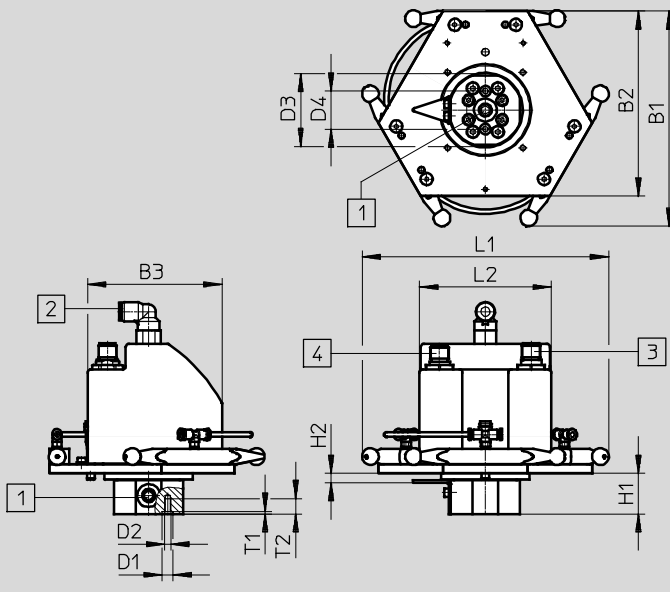

- 1 Supply port outlet
- 2 Supply port rotary through-feed
- 3 Connection for motor cable
- 4 Connection for encoder cable

Type	B1	B2	B3	D1 ∅ H7	D2	D3 ∅	D4 ∅	H1	H2 +1	L1	L2	T1	T2
EXPT-...	141	122	88	7	M4	48	25	27	6	162	86	1.6	10

# Parallel kinematic robots EXPT, tripod

Technical data

**Dimensions**

Download CAD data → [www.festo.com](http://www.festo.com)

Parallel kinematic robot

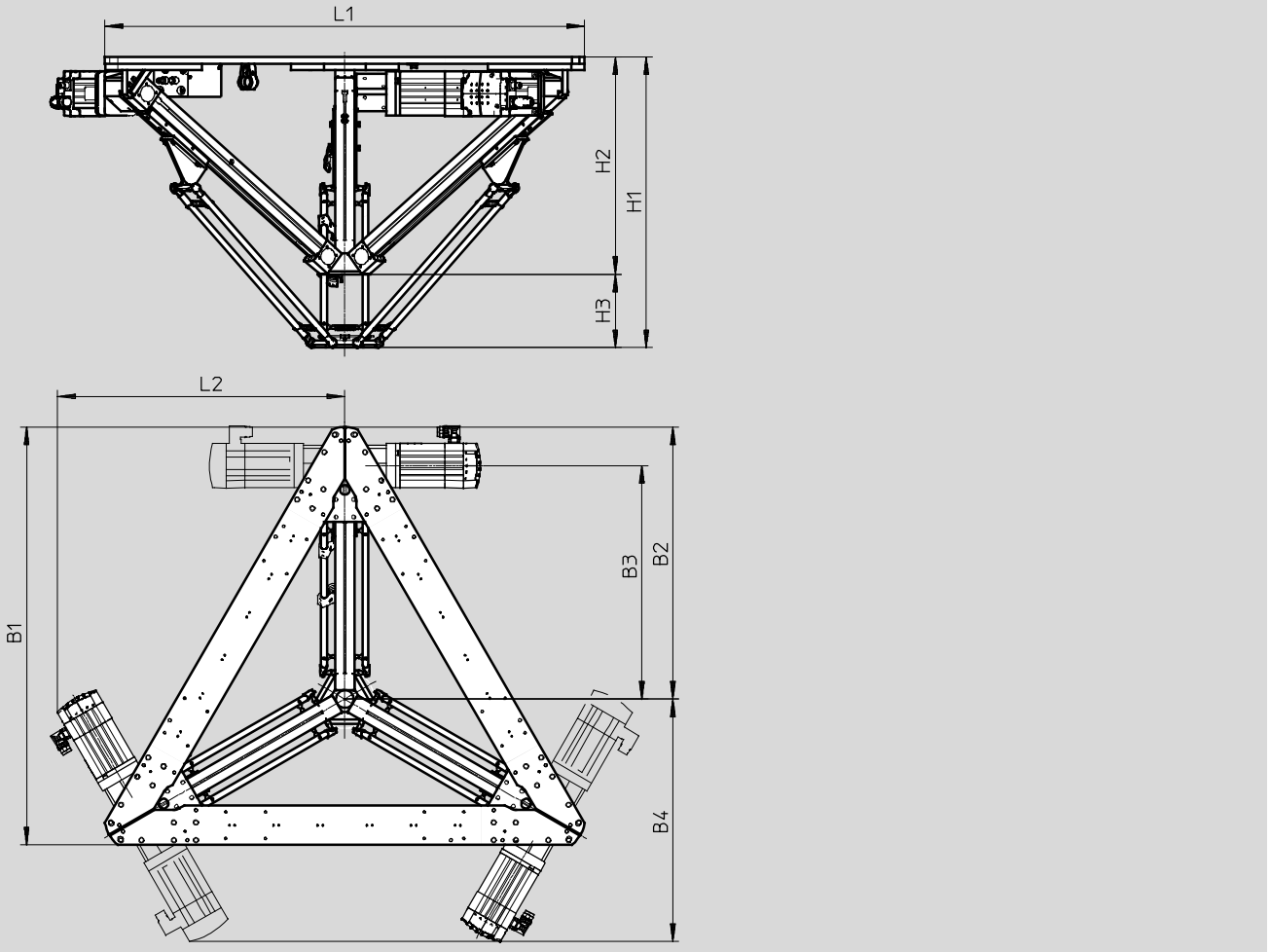

Type	B1	B2	B3	B4	H1	H2	H3	L1	L2
EXPT-45	947	617	530	549	659	493	166	1,088	652
EXPT-70	1,077	703	622	590	727	561	166	1,238	727
EXPT-95	1,213	794	705	626	827	636	191	1,394	803
EXPT-120	1,355	888	800	672	944	710	234	1,558	885



# Parallel kinematic robots EXPT, tripod

Technical data

**Dimensions**

Download CAD data → [www.festo.com](http://www.festo.com)

Mounting holes on the mounting frame

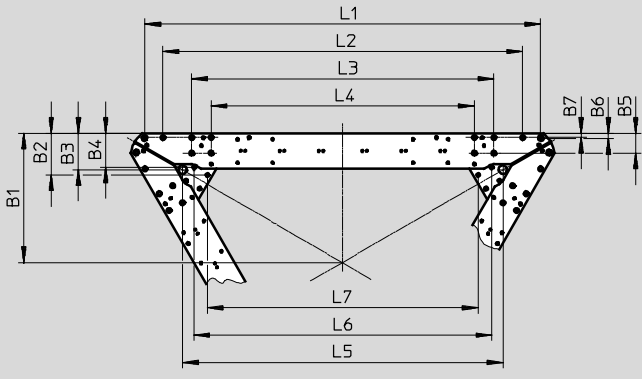

Type	B1	B2	B3	B4	B5	B6	B7
EXPT-45	330.8	107.2	93.5	87.2	51	12.3	11
EXPT-70	374.1	107.2	93.5	87.2	51	12.3	11
EXPT-95	419.3	107.2	93.5	87.2	51	12.3	11
EXPT-120	466.6	107.2	93.5	87.2	51	12.3	11

Type	L1	L2	L3	L4	L5	L6	L7
EXPT-45	1,017	923	775.4	675.4	822	794	694.6
EXPT-70	1,167.1	1,073.1	925.5	825.5	972.1	914	844.7
EXPT-95	1,323.7	1,229.7	1,082.1	982.1	1,128.7	1,070.6	1,001.3
EXPT-120	1,487.5	1,393.5	1,245.9	1,145.9	1,292.5	1,234.4	1,165.1

# Parallel kinematic robots EXPT, tripod

Technical data

**Dimensions**

Download CAD data → [www.festo.com](http://www.festo.com)

Interference contour within the operating area

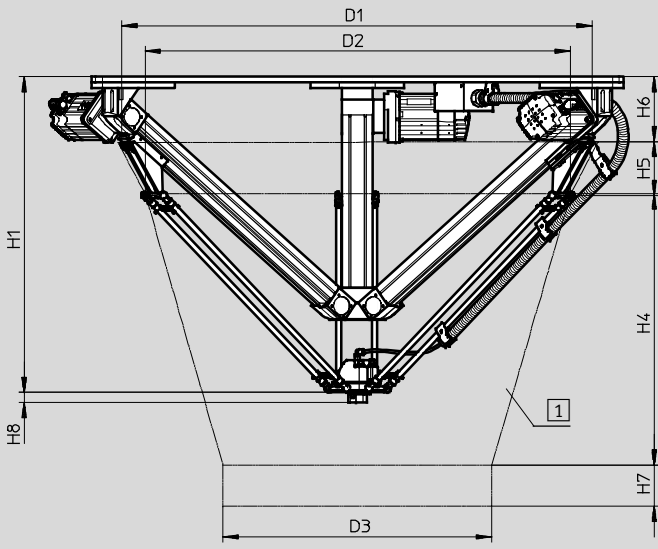

**1** Interference contour

Type	D1	D2	D3	H1	H4	H5	H6	H7	H8
EXPT-45	915	770	620	659	553	105	138	100	27
EXPT-70	1,090	925	870	727	647	105	159	100	27
EXPT-95	1,250	1,115	1,120	827	729	155	188	100	27
EXPT-120	1,410	1,285	1,370	944	877	155	192	100	27

# Parallel kinematic robots EXPT, tripod

Technical data

## Pin allocations

### Axis motor

Motor

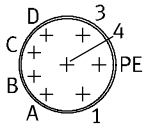

Encoder

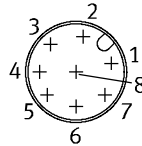

Pin	Function
1	Phase U
PE	PE (protective earth)
3	Phase W
4	Phase V
A	Temperature sensor $M_T+$
B	Temperature sensor $M_T-$
C	Holding brake BR+
D	Holding brake BR-

Pin	Function
1	-SENS
2	+SENS
3	DATA
4	DATA/
5	0 V
6	CLOCK/
7	CLOCK
8	UP

### Front unit motor

Motor

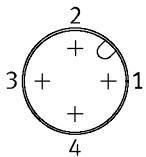

Encoder

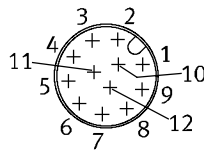

Pin	Function
1	U
2	V
3	W
4	PE

Pin	Function
1	A
2	A\
3	B
4	B\
5	Z
6	Z\
7	U
8	V
9	W
10	GND
11	5 V
12	Shield

## Parallel kinematic robots EXPT, tripod

Ordering data – Modular products

Ordering table							
Size	45	70	95	120	Condi- tions	Code	Enter code
<b>M</b> Module No.	<b>569797</b>	<b>569798</b>	<b>569799</b>	<b>569800</b>			
Product type	EXPT series T					<b>EXPT</b>	EXPT
Working space	[mm] 450	-				<b>-45</b>	
	[mm] -	700	-			<b>-70</b>	
	[mm] -	950		-		<b>-95</b>	
	[mm] -	1,200				<b>-120</b>	
Drive	DGE-25		-			<b>-E1</b>	
	-		EGC-80			<b>-E4</b>	
Attachment components	Without rotary drive					<b>-T0</b>	
	Rotary drive, size 8					<b>-T1</b>	
	Rotary drive, size 8 with pneum. air through-feed					<b>-T2</b>	
	Rotary drive, size 11					<b>-T3</b>	
	Rotary drive, size 11 with pneum. air through-feed					<b>-T4</b>	
Motor attachment position	A1/A2/A3 rear					<b>-HHH</b>	
	A3 front, A1/A2 rear					<b>-HHV</b>	
	A2 front, A1/A3 rear					<b>-HVH</b>	
	A2/A3 front, A1 rear					<b>-HVV</b>	
	A1 front, A2/A3 rear					<b>-VHH</b>	
	A1/A3 front, A2 rear					<b>-VHV</b>	
	A1/A2 front, A3 rear					<b>-VVH</b>	
	A1/A2/A3 front					<b>-VVV</b>	
<b>O</b> Particle protection	Standard						
	-		Protected version			<b>-P8</b>	

Transfer order code

**EXPT**  -  -  -  -  -

# Parallel kinematic robots EXPT, tripod

Ordering data – Modular products

Ordering table								
Size	45	70	95	120	Condi- tions	Code	Enter code	
O	Control system	None						
		Mounting plate					-C	
		Control cabinet					-CC	
	Multi-axis controller	None						
		With CMXR-C1					-C1	
		With CMXR-C2, with integrated PLC					-C2	
	Operator terminal	None						
		With teach pendant CDSA					-B	
	Cable length	None						
		5 m					-5K	
		10 m					-10K	
		15 m					-15K	
Presetting	Standard							
	With calibration					-S		
M	Documentation in the languages	German					DE	
		English					EN	
		Spanish					ES	
		French					FR	
		Italian					IT	
		Russian					RU	
		Swedish					SV	
		Chinese					ZH	

 Note

To order a parallel kinematic robot, please get in touch with your local Festo contact person.

The parallel kinematic robots may only be commissioned by a specially trained technician (robotics specialist).

The following knowledge is required:

- Specialist knowledge of robotics and CoDeSys

- Knowledge of handling motor controllers CMMP and multi-axis controllers CMXR
- Knowledge of handling parallel kinematic systems

Transfer order code

-  -  -  -  -  -

## Parallel kinematic robots EXPT, tripod

Accessories

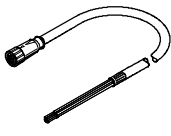
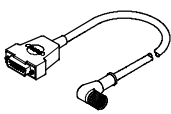
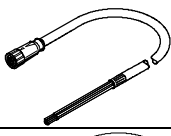
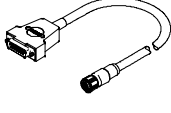
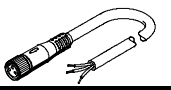

Ordering data			
	Cable length [m]	Part No.	Type
<b>Connection from axis motor to motor controller in the control cabinet</b>			
	Motor cable NEBM		
	5	550310	NEBM-M23G6-E-5-N-LE7
	10	550311	NEBM-M23G6-E-10-N-LE7
	15	550312	NEBM-M23G6-E-15-N-LE7
	X length <sup>1)</sup>	550313	NEBM-M23G6-E- -N-LE7
	Encoder cable NEBM		
	5	550318	NEBM-M12W8-E-5-N-S1G15
	10	550319	NEBM-M12W8-E-10-N-S1G15
	15	550320	NEBM-M12W8-E-15-N-S1G15
	X length <sup>1)</sup>	550321	NEBM-M12W8-E- -N-S1G15
<b>Connection from interface housing to the motor controller in the control cabinet</b>			
	Motor cable NEBM		
	15	571907	NEBM-M12G4-RS-15-N-LE4
	Encoder cable NEBM		
	15	571915	NEBM-M12G12-RS-15-N-S1G15
<b>Connecting cable NEBU for rod loss detection or reference sensor of the rotary drive</b>			
	5	541334	NEBU-M8G3-K-5-LE3
	10	541332	NEBU-M8G3-K-10-LE3
	15	575986	NEBU-M8G3-K-15-LE3

1) Max. 25 m

## Parallel kinematic robots EXPT, tripod

Accessories

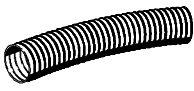
FESTO

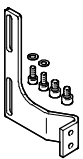
Ordering data			
	Description	Part No.	Type
Protective conduit MKG			
	2 m are required per axis	177589	MKG-23-PG-29
Tubing holder EAHM			
	For attaching the protective conduit	1574902	EAHM-E10-TH
Angle kit EAHM			
	For attaching the tubing holder to the connection block	2075203	EAHM-E10-AK
		2075842	EAHM-E10-AK-P8 <sup>1)</sup>

1) For the variant EXPT-...-P8

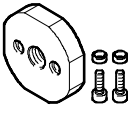
Ordering data			
	Description	Part No.	Type
Adapter kit EAHA			
	For suction gripper ESG- (retainer size 2)	1574224	EAHA-R2-M12P
	For suction gripper ESG- (retainer size 3 and 4)	1574227	EAHA-R2-M14P

# Parallel kinematic robots EXPT, tripod

Accessories

**Adapter kit**  
**DHAA, HAPG**

Material:  
Wrought aluminium alloy  
Free of copper and PTFE  
RoHS-compliant

 **Note**  
The kit includes the individual mounting interface as well as the necessary mounting material.

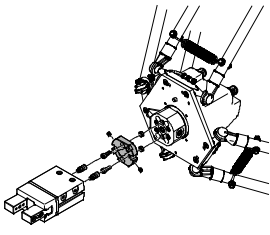
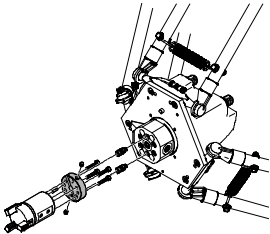
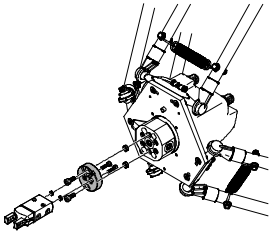
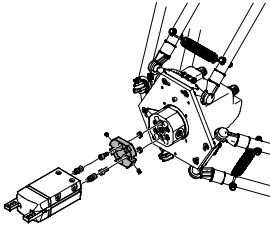
Gripper combinations with adapter kit		Download CAD data → <a href="http://www.festo.com">www.festo.com</a>	
Grippers	Size	Adapter kit	
		Part No.	Type
<b>Parallel gripper</b>			
	DHPS, standard		
	6	187566	HAPG-SD2-12
	10	184477	HAPG-SD2-1
	16	184478	HAPG-SD2-2
	HGPT-B, heavy-duty		
	16	564958	DHAA-G-Q5-12-B8-16
	20	564955	DHAA-G-Q5-16-B8-20
	25	537181	HAPG-SD2-25
	HGPL, heavy-duty with long stroke		
	14 (stroke 40/60/80)	537310	HAPG-SD2-31
	HGPC		
	12	542671	HAPG-SD2-41
	16	542668	HAPG-SD2-42
	HGPD, sealed		
	16	564958	DHAA-G-Q5-12-B8-16
20	564955	DHAA-G-Q5-16-B8-20	
25	537181	HAPG-SD2-25	
<b>Three-point gripper</b>			
	DHDS, standard		
	16	187567	HAPG-SD2-13
	HGDT, heavy-duty		
25	542439	HAPG-SD2-32	
<b>Radial gripper</b>			
	DHRS, standard		
	10	187566	HAPG-SD2-12
	16	184477	HAPG-SD2-1
	25	184478	HAPG-SD2-2
	HGRT, heavy-duty		
	16	1273999	DHAA-G-Q5-16-B11-16
	HGRC		
	16	542668	HAPG-SD2-42
<b>Angle gripper</b>			
	DHWS, standard		
	10	187566	HAPG-SD2-12
	16	184477	HAPG-SD2-1
	25	184478	HAPG-SD2-2
	HGWC		
	16	542668	HAPG-SD2-42