

Electric slides EGSK/EGSP

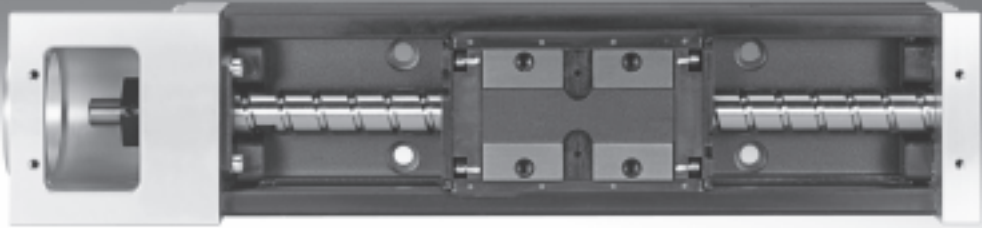

Electric slides EGSK/EGSP

Key features

At a glance

Precision embedded in steel

The new generation of electric slide axes EGSK and EGSP impresses with its precision, repetition accuracy, compactness and rigidity.

The two axis series form a complete range with a uniform design, long service life and standardised mounting interfaces. The U-shaped steel housing serves simultaneously as a guide rail. The slide combines

linear guide elements and the spindle nuts of the ball screw in one component, thus avoiding the accumulation of production tolerances.

Both series come in three accuracy classes with the option of an additional slide (series 33 and 46 are also available in a short-slide design).

Electric slide EGSK

- Recirculating ball bearing guide and ball screw without caged balls
- Standard designs available ex-stock

Electric slide EGSP

- Recirculating ball bearing guide with caged balls
- Size 33, 46 features a ball screw with caged balls
- Low-maintenance
- Uniform operating behaviour with very low noise levels

Linear guide with caged balls

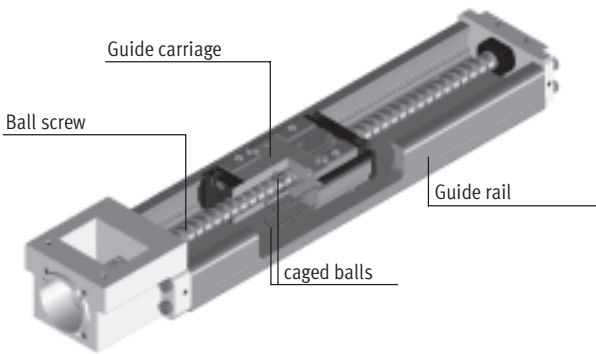

The linear guide features four rows of balls circulating within the guide carriage. In the loaded area, the balls run between the honed grooves of the guide carriage and guide rail until they are returned by means of the reversers in the end plates and the return channels. The very rigid design of the guide carriage enables precision linear movements to be

executed with impressive dynamism. The four rows of balls are arranged at a contact angle of 45°, giving the guide carriage the same basic load ratings in both radial coordinate directions. This type of guide can therefore be used in any mounting position for a wide range of load directions.

Axis characteristics

The specifications shown in the table are maximum values.

The precise values for each of the variants can be found in the relevant technical data section.

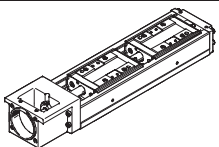
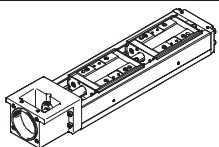
Design	Size	Working stroke [mm]	Speed [m/s]	Repetition accuracy [µm]	Feed force [N]	Guide characteristics				
						Forces and torques				
						F _y [N]	F _z [N]	M _x [Nm]	M _y [Nm]	M _z [Nm]
Electric slide EGSK						→ 6				
	15	25 ... 100	0.33	±3	57	1,185	1,185	13	3.7	3.7
	20	25 ... 125	1.10	±3	133	2,204	2,204	28.7	9.2	9.2
	26	50 ... 200	0.83	±3	184	3,528	3,528	60	20.4	20.4
	33	100 ... 630	1.10	±3	239	3,920	3,920	79.5	26	26
	46	200 ... 840	1.48	±3	392	7,809	7,809	231	77.3	77.3
Electric slide EGSP						→ 22				
	20	25 ... 125	0.6	±3	112	2,929	2,929	36.3	12.5	12.5
	26	50 ... 200	0.6	±3	212	5,028	5,028	81.5	31.6	31.6
	33	100 ... 630	2	±3	466	4,559	4,559	90.3	32.1	32.1
	46	200 ... 840	2	±3	460	8,935	8,935	258	94	94

Electric slides EGSK/EGSP

Key features

Complete system comprising electric slide, motor, motor controller and motor mounting kit
 Electric slide with recirculating ball bearing guide



Motor

→ 35



- 1 Servo motor EMMS-AS
- 2 Stepper motor EMMS-ST

Note

A range of specially matched complete solutions is available for the electric slides EGSK, EGSP and the motors.

Motor controller

Technical data → Internet: motor controller



- 1 Servo motor controller CMMP-AS, CMMS-AS
- 2 Stepper motor controller CMMS-ST

Motor mounting kit

→ 35

Axial kit



Kit comprising:

- Motor flange
- Coupling
- Screws

Electric slides EGSK/EGSP

Peripherals overview

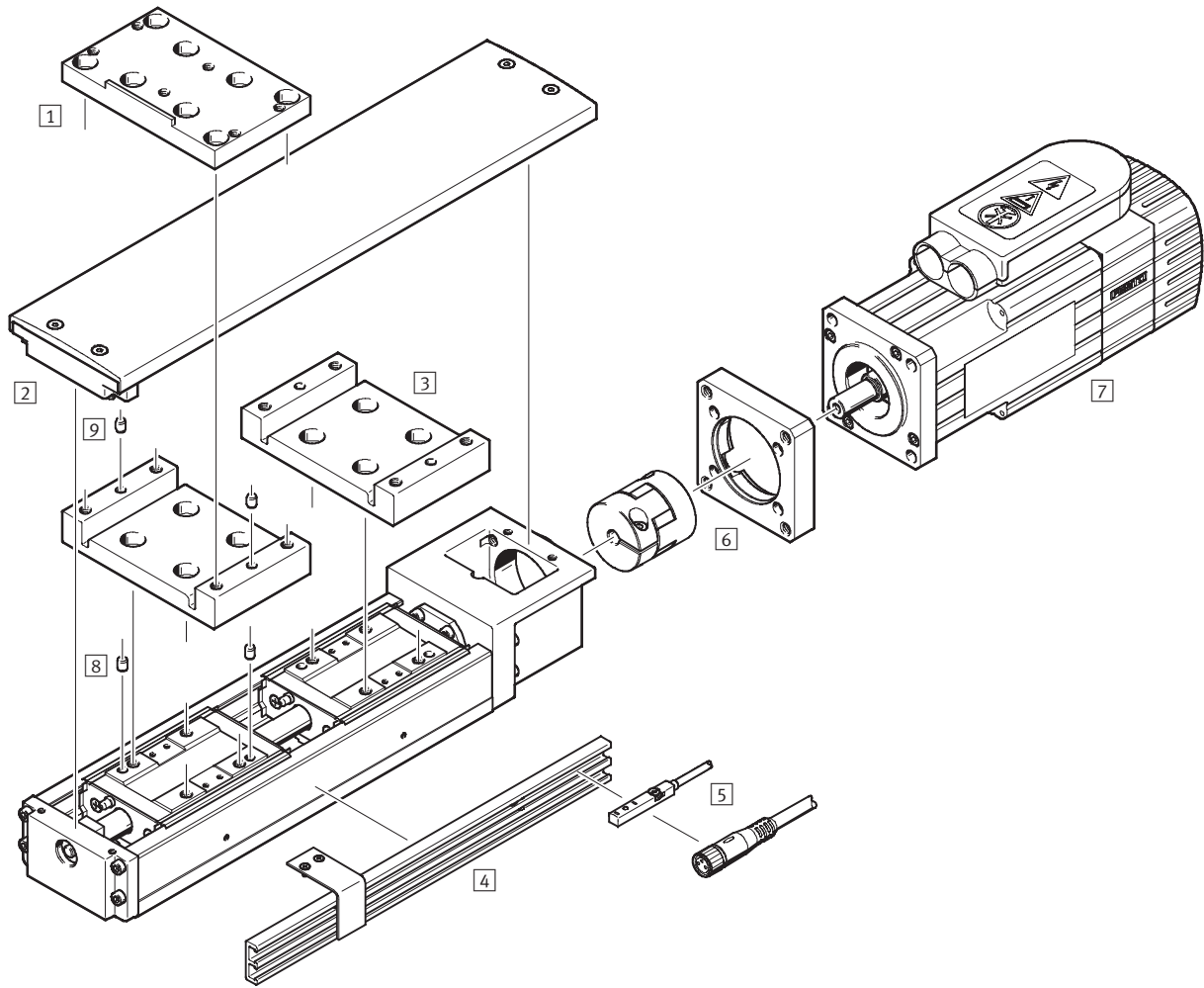

Electric slides EGSK/EGSP

Peripherals overview

FESTO

Accessories		
Type	Brief description	→ Page/Internet
1 Cross connecting kit EHAM-S1	For mounting an assembly axis EGSK/EGSP at right angles on the slide of a basic axis EGSK/EGSP. The assembly axis is one size smaller than the respective basic axis.	38
2 Covering kit EASC-S1	For covering the axis profile that is open at the top. The kit includes a slide adapter EASA-S1.	40
3 Slide adapter EASA-S1	Required to mount the effective load in combination with the covering kit for axis variants with additional slide.	39
4 Sensor strip EAPR-S1-S	<ul style="list-style-type: none"> • For mounting the inductive proximity sensor SIES-8M on the electric slide. • Switching lugs are included in the scope of delivery. 	42
5 Proximity sensor SIES-8M	Inductive proximity sensor, for T-slot.	43
6 Axial kit EAMM-A	For axial motor mounting (comprising: coupling and motor flange).	35
7 Motor EMMS	Motors specially matched to the axis, with or without brake.	35
8 Centring pin ZBS	For centring loads and attachments on the slide.	43
9 Centring pin ZBS	For centring loads and attachments on the slide adapter.	43

Electric slides EGSK

Type codes



		EGSK	-	20	-	125	-	6P	-	H	-		-	Z
Type														
EGSK	Electric slide													
Size														
Stroke [mm]														
Spindle pitch														
Accuracy														
-	Standard													
H	High accuracy													
P	Precision design													
Slide design														
-	Standard slide													
S	Slide, short													
Additional slide														
-	No additional slide													
Z	Additional slide													

Electric slides EGSK

Technical data

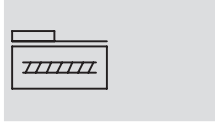
Function



-  - Size
15 ... 46
-  - Stroke length
25 ... 840 mm



General technical data													
Size		15 ²⁾		20		26		33		46			
Spindle pitch		1	2	1	6	2	6	6	10	10	20		
		Code ¹⁾											
Constructional design		Electromechanical linear axis with recirculating ball bearing spindle											
Guide		Recirculating ball bearing guide											
Installation position		Any											
Type of mounting for effective load		Female thread											
		Centring sleeve				Locating pin							
Working stroke ³⁾	-	[mm]		25 ... 100		25 ... 125		50 ... 200		100 ... 600		200 ... 800	
	S	[mm]		-		-		-		130 ... 630		240 ... 840	
Max. feed force	-/H ⁴⁾	[N]		36	19	69	72	116	116	150	148	264	192
F _{x,max}	P ⁵⁾	[N]		57	31	110	133	184	184	239	183	392	343
Max. driving torque	-/H ⁴⁾	[Ncm]		0.6	0.6	1.1	6.9	3.7	11	14	24	42	61
M _{Driving,max}	P ⁵⁾	[Ncm]		0.9	1.0	1.8	13	5.9	18	23	29	62	109
No-load torque	-/H	[Ncm]		0.4	0.4	0.5	0.5	1.5	1.5	7	7	10	10
M _{No-load}	P	[Ncm]		0.8	0.8	1.2	1.2	4.0	4.0	15	15	17	17
Max. rotational speed ⁶⁾		[1/min]		9,600	9,900	11,400	7,900	8,400	5,900	4,700	4,700	3,100	3,100
Max. speed ⁶⁾	-/H	[m/s]		0.16	0.33	0.19	0.79	0.28	0.59	0.47	0.79	0.52	1.05
	P	[m/s]		0.16	0.33	0.19	1.10	0.28	0.83	0.66	1.10	0.74	1.48
Max. acceleration		[m/s ²]		10		10		10		20		20	
Homing		Inductive proximity sensor SIES-8M											

- 1) Variant code → 6
- 2) Size 15 only comes in the accuracy classes H and P
- 3) Maximum travel distance → 15
In combination with an additional slide, the working stroke is reduced by the length of the additional slide and the distance between the two slides
- 4) Loads are based on a service life specification of 5×10^8 rotations
- 5) Loads are based on a service life specification of 1.25×10^8 rotations
- 6) Reduced speeds with sizes 33 and 46 with long strokes → 9

Operating and environmental conditions		
Ambient temperature	[°C]	0 ... +40
Relative air humidity	[%]	0 ... 95 (non-condensing)

Weight [kg]											
Size		15		20		26		33		46	
		Code ¹⁾									
Basic weight with 0 mm stroke ²⁾	-			0.16	0.38	0.78	1.38	5.17			
	S			-	-	-	1.28	4.77			
Additional weight per 100 mm stroke	-			0.12	0.27	0.42	0.63	1.27			
Moving load	-			0.04	0.07	0.15	0.31	0.91			
	S			-	-	-	0.17	0.57			
Additional slide Z	-			0.04	0.07	0.15	0.31	0.91			
	S			-	-	-	0.17	0.57			

- 1) Variant code → 6
- 2) Including slide, without additional slide

Electric slides EGSK

Technical data

Accuracy data [µm]			15	20	26	33	46
Size	Stroke	Code ¹⁾					
Repetition accuracy ²⁾		–	–	±10	±10	±10	±10
		H	±4	±5	±5	±5	±5
		P	±3	±3	±3	±3	±3
Operating parallelism	25 ... 340	H	20	25	25	25	35
	400 ... 540	H	–	–	–	35	35
	600 ... 640	H	–	–	–	40	40
	800 ... 840	H	–	–	–	–	50
	25 ... 340	P	10	10	10	10	15
	400 ... 540	P	–	–	–	15	15
Max. reversing play		–	–	20	20	20	20
		H	10	10	10	20	20
		P	2	3	3	3	3

1) Variant code → 6

2) The repetition accuracy that can be achieved with a motor/axis system is also influenced by the angle resolution of the motor and the chosen control parameters. The specified repetition accuracy cannot, therefore, be achieved with all motors.

Materials

Sectional view

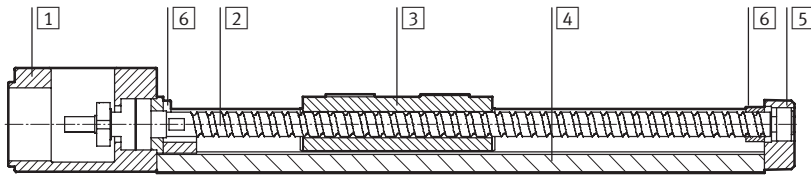

Electric slide	
1 Drive cover	Die-cast aluminium, coated
2 Spindle	Steel
3 Slide	Steel
4 Profile	High-alloy steel
5 End cap	Die-cast aluminium, coated
6 Buffer	Ethylene vinyl acetate copolymer
Note on materials	RoHS-compliant
	Contains PWIS (paint-wetting impairment substances)

Mass moment of inertia											
Size		15		20		26		33		46	
Spindle pitch		1	2	1	6	2	6	6	10	10	20
	Code ¹⁾										
J ₀	[kg mm ²]	0.030	0.033	0.087	0.143	0.355	0.479	1.15	1.65	8.43	15.3
	S [kg mm ²]	–	–	–	–	–	–	0.791	1.07	6.01	10.3
J _S per 100 mm stroke	[kg mm ² /100 mm]	0.048		0.099		0.314		0.766		3.877	
J _L per kg effective load	[kg mm ² /kg]	0.03	0.10	0.03	0.91	0.10	0.91	0.91	2.53	2.53	10.13
J _W per additional slide	[kg mm ²]	0.001	0.004	0.002	0.058	0.016	0.14	0.28	0.79	2.31	9.22
	S [kg mm ²]	–	–	–	–	–	–	0.16	0.43	1.44	5.78

1) Variant code → 6

The mass moment of inertia J_A of the entire axis is calculated as follows:

$$J_A = J_0 + J_W + J_S \times \text{working stroke} + J_L \times m_{\text{Effective load}}$$

Electric slides EGSK

Technical data

Speed v, rotational speed n as a function of working stroke l

EGSK-33-...-6P

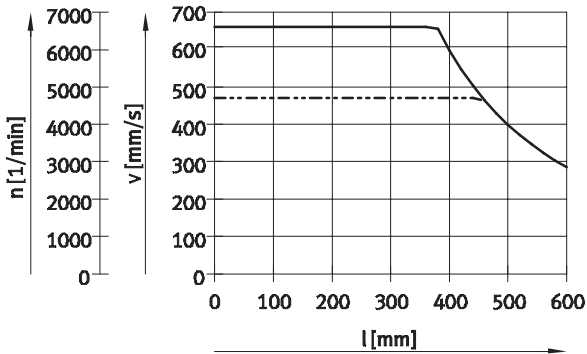

— EGSK-33-...-6P-P
 - - - - EGSK-33-...-6P, EGSK-33-...-6P-H

EGSK-33-...-10P

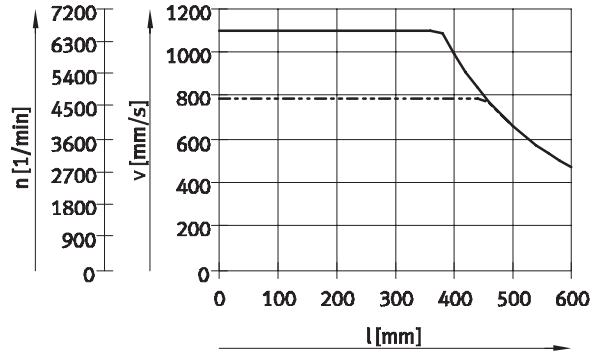

— EGSK-33-...-10P-P
 - - - - EGSK-33-...-10P, EGSK-33-...-10P-H

EGSK-46-...-10P

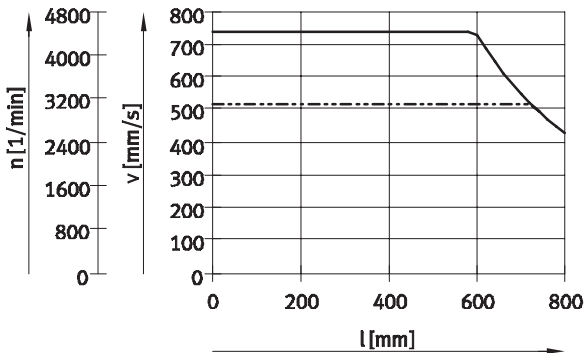

— EGSK-46-...-10P-P
 - - - - EGSK-46-...-10P, EGSK-46-...-10P-H

EGSK-46-...-20P

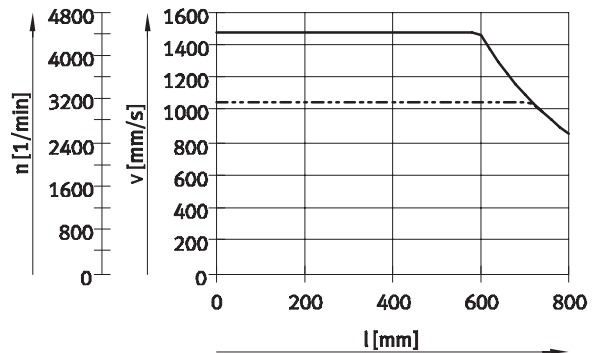

— EGSK-46-...-20P-P
 - - - - EGSK-46-...-20P, EGSK-46-...-20P-H

2nd moment of area

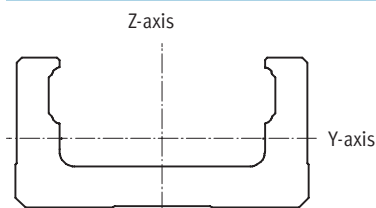

Size		15	20	26	33	46
ly	[mm ⁴]	908	6,100	17,000	62,000	240,000
lz	[mm ⁴]	14,200	62,000	150,000	380,000	1,500,000

Electric slides EGSK

Technical data

Characteristic load values

The indicated forces and torques refer to the centre axis of the spindle.

The coordinate zero point is the point where the centre of the guide and the longitudinal centre of the slide intersect.

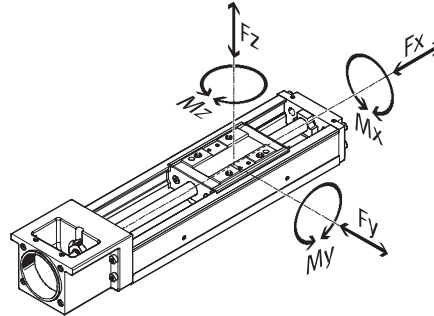

Note

PositioningDrives
sizing software
www.festo.com

Permissible dynamic forces and torques¹⁾

Size			15 ³⁾		20		26		33		46		
Spindle pitch			1	2	1	6	2	6	6	10	10	20	
	Code ²⁾												
F _y max., F _z max.	-/H ⁴⁾	-	[N]	747	593	1,389	764	2,223	1,541	2,469	2,083	4,919	3,904
	P ⁵⁾	-	[N]	1,185	941	2,204	1,213	3,528	2,446	3,920	3,306	7,809	6,198
	-/H ⁴⁾	S	[N]	-	-	-	-	-	-	1,043	880	2,514	1,995
	P ⁵⁾	S	[N]	-	-	-	-	-	-	1,656	1,396	3,990	3,167
M _x max.	-/H ⁴⁾	-	[Nm]	8.2	6.5	18.1	9.9	37.8	26.2	50.1	42.2	145	115
	P ⁵⁾	-	[Nm]	13	10.3	28.7	15.8	60	41.6	79.5	67.1	231	183
	-/H ⁴⁾	S	[Nm]	-	-	-	-	-	-	21.2	17.8	74.4	59
	P ⁵⁾	S	[Nm]	-	-	-	-	-	-	33.6	28.3	118	93.7
M _y max., M _z max.	-/H ⁴⁾	-	[Nm]	2.3	1.9	5.8	3.2	12.9	8.9	16.4	13.8	48.7	38.7
	P ⁵⁾	-	[Nm]	3.7	2.9	9.2	5.1	20.4	14.1	26	21.9	77.3	61.4
	-/H ⁴⁾	S	[Nm]	-	-	-	-	-	-	3.8	3.2	13.6	10.8
	P ⁵⁾	S	[Nm]	-	-	-	-	-	-	6	5	21.6	17.1

- 1) Calculated with a speed-dependent load factor f_w of 1.2
- 2) Variant code → 6
- 3) Size 15 only comes in the accuracy classes H and P
- 4) Loads are based on a service life specification of 5 x 10⁸ rotations and a load factor f_w of 1.2
- 5) Loads are based on a service life specification of 1.25 x 10⁸ rotations and a load factor f_w of 1.2

Basic load ratings

Size			15 ²⁾		20		26		33		46	
Spindle pitch			1	2	1	6	2	6	6	10	10	20
	Code ¹⁾											
Ball screw												
Static C ₀ ball screw	-/H	[N]	660	410	1,170	1,450	4,020	3,510	4,900	2,840	6,760	7,150
	P	[N]	660	410	1,170	1,600	4,020	3,900	2,740	1,570	3,720	5,290
Dynamic C _{dyn} ball screw	-/H ³⁾	[N]	340	230	660	860	2,350	1,950	2,840	1,760	3,140	3,040
	P ³⁾	[N]	340	230	660	1,060	2,350	2,390	2,250	1,370	2,940	3,430
Fixed bearing												
Static C ₀ bearing		[N]	290		1,240		1,760		2,590		3,240	
Dynamic C _{dyn} bearing ³⁾		[N]	590		1,000		1,380		1,790		6,660	

- 1) Variant code → 6
- 2) Size 15 only comes in the accuracy classes H and P
- 3) Dynamic basic load ratings are based on a basic service life of 10⁶ rotations

Electric slides EGSK

Technical data

FESTO

Basic load ratings												
Size			15 ²⁾		20		26		33		46	
Spindle pitch			1	2	1	6	2	6	6	10	10	20
Code ¹⁾												
Linear guide												
Static C _{0,guide}	-	[N]	3,450		6,300		12,150		20,200		45,500	
	S	[N]	-		-		-		10,000		22,700	
Dynamic c _{dyn,guide} ³⁾	-	[N]	1,532		2,849		5,746		9,207		21,747	
	S	[N]	-		-		-		3,889		11,112	
Torque equivalence factors												
k _x	-	[1/m]	90.9		76.9		58.8		49.3		33.8	
	S	[1/m]	-		-		-		49.3		33.8	
k _y , k _z	-	[1/m]	319.9		238.7		172.9		151		101	
	S	[1/m]	-		-		-		277.1		185	

1) Variant code → 6

2) Size 15 only comes in the accuracy classes H and P

3) Dynamic basic load ratings are based on a basic service life of 100 km

Speed-dependent load factor f_w

f_w = 1.0 ... 1.2 (v ≤ 0.25 m/s)

f_w = 1.2 ... 1.5 (0.25 m/s ≤ v ≤ 1.0 m/s)

f_w = 1.5 ... 2.0 (1.0 m/s ≤ v ≤ 2.0 m/s)

f_w = 2.0 ... 3.5 (v ≥ 2.0 m/s)

Calculation of the maximum feed force F_x

$$F_{x,max} = \frac{1}{f_w} \times \frac{\text{Min}[C_{dyn,KGT}; C_{dyn,bearing}]}{\sqrt[3]{\frac{L_{ref,rot}}{10^6}}}$$

Calculation of the maximum forces F_{y/z} and torques M_{x/y/z}

$$F_{y/z,max} = \frac{1}{f_w} \times \frac{C_{dyn,guide}}{\sqrt[3]{\frac{L_{ref,km}}{100km}}}$$

$$M_{x/y/z,max} = \frac{1}{k_{x/y/z}} \times \frac{1}{f_w} \times \frac{C_{dyn,guide}}{\sqrt[3]{\frac{L_{ref,km}}{100km}}}$$

Electric slides EGSK

Technical data

Calculation of the service life

Size	15		20		26		33		46		
Spindle pitch P	1	2	1	6	2	6	6	10	10	20	
	Code ¹⁾										
Reference service life	-/H	5 x 10 ⁸									
in rotations, L _{ref,rot}	P	1.25 x 10 ⁸									
Reference service life	-/H [km]	500	1,000	500	3,000	1,000	3,000	3,000	5,000	5,000	10,000
in kilometres, L _{ref,km}	P [km]	125	250	125	750	250	750	750	1,250	1,250	2,500

1) Variant code → 6

1 Representation of the loads

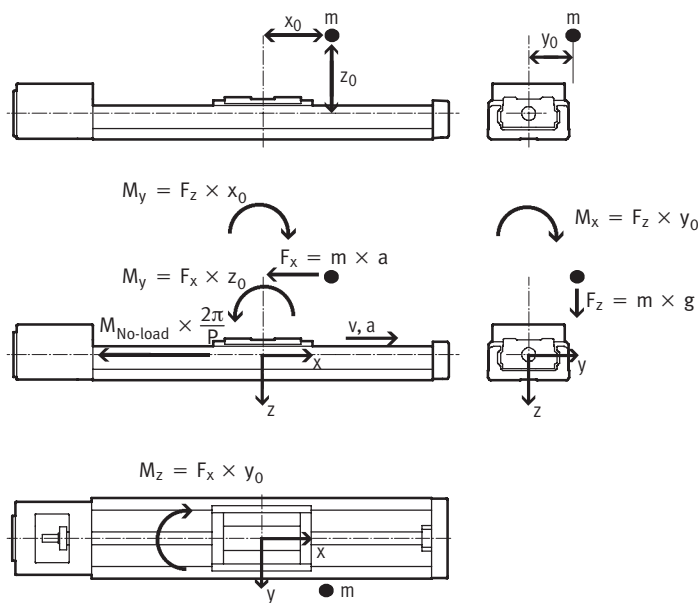

2 Determination of the loads over the travel cycle

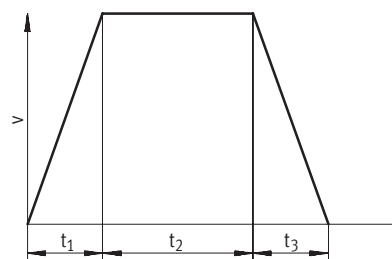

$$q_1 = \frac{t_1}{t_{tot}} \quad q_2 = \frac{t_2}{t_{tot}} \quad q_3 = \frac{t_3}{t_{tot}}$$

$$t_{tot} = t_1 + t_2 + t_3$$

v	Speed
t ₁	Acceleration time
t ₂	Constant travel time
t ₃	Deceleration time
q _{1/2/3}	Relative time of the cycle phases
t _{tot}	Cycle time

Ball screw

For t₁: $F_{x1} = - (m \times a) - (M_{No-load} \times \frac{2\pi}{P})$

For t₂: $F_{x2} = - (M_{No-load} \times \frac{2\pi}{P})$

For t₃: $F_{x3} = m \times a - (M_{No-load} \times \frac{2\pi}{P})$

F _{x1/2/3}	Calculated force load per cycle phase
F _{x,dyn}	Calculated average force load
m	Effective load (centre of gravity)
a	Acceleration
M _{No-load}	No-load torque → 7
P	Spindle pitch → 7
q _{1/2/3}	Relative time of the cycle phases

$$F_{x,dyn} = \sqrt[3]{q_1 \times |F_{x1}|^3 + q_2 \times |F_{x2}|^3 + q_3 \times |F_{x3}|^3}$$

Electric slides EGSK

Technical data

2 Determination of the loads over the travel cycle

Linear guide

For t₁: a →, v →

$$F_{y1} = 0$$

$$F_{z1} = m \times g$$

$$M_{x1} = F_z \times y_0 = m \times g \times y_0$$

$$M_{y1} = -F_z \times x_0 + F_x \times z_0 = -m \times g \times x_0 + m \times a \times z_0$$

$$M_{z1} = F_x \times y_0 = m \times a \times y_0$$

For t₂: a = 0, v →

$$F_{y2} = 0$$

$$F_{z2} = m \times g$$

$$M_{x2} = F_z \times y_0 = m \times g \times y_0$$

$$M_{y2} = -F_z \times x_0 = -m \times g \times x_0$$

$$M_{z2} = 0$$

For t₃: a ←, v →

$$F_{y3} = 0$$

$$F_{z3} = m \times g$$

$$M_{x3} = F_z \times y_0 = m \times g \times y_0$$

$$M_{y3} = -F_z \times x_0 - F_x \times z_0 = -m \times g \times x_0 - m \times a \times z_0$$

$$M_{z3} = -F_x \times y_0 = -m \times a \times y_0$$

$$F_{y,dyn} = \sqrt[3]{q_1 \times |F_{y1}|^3 + q_2 \times |F_{y2}|^3 + q_3 \times |F_{y3}|^3}$$

$$F_{z,dyn} = \sqrt[3]{q_1 \times |F_{z1}|^3 + q_2 \times |F_{z2}|^3 + q_3 \times |F_{z3}|^3}$$

$$M_{x,dyn} = \sqrt[3]{q_1 \times |M_{x1}|^3 + q_2 \times |M_{x2}|^3 + q_3 \times |M_{x3}|^3}$$

$$M_{y,dyn} = \sqrt[3]{q_1 \times |M_{y1}|^3 + q_2 \times |M_{y2}|^3 + q_3 \times |M_{y3}|^3}$$

$$M_{z,dyn} = \sqrt[3]{q_1 \times |M_{z1}|^3 + q_2 \times |M_{z2}|^3 + q_3 \times |M_{z3}|^3}$$

3 Total load

Ball screw

$$\frac{|F_{x,dyn}|}{F_{x,max}} \leq f_v$$

$F_{x,dyn}$	Calculated average force load
$F_{x,max}$	Max. permissible force load → 7
f_v	Load comparison factor → 14

Linear guide

$$\frac{|F_{y,dyn}|}{F_{y,max}} + \frac{|F_{z,dyn}|}{F_{z,max}} + \frac{|M_{x,dyn}|}{M_{x,max}} + \frac{|M_{y,dyn}|}{M_{y,max}} + \frac{|M_{z,dyn}|}{M_{z,max}} \leq f_v$$

$F_{y/z,dyn}$	Calculated average force load
$F_{y/z,max}$	Max. permissible force load → 10
$M_{x/y/z,dyn}$	Calculated average torque load
$M_{x/y/z,max}$	Max. permissible torque load → 10
f_v	Load comparison factor → 14

Electric slides EGSK

Technical data

4 Determination of the load comparison factor f_v

$$f_v = \frac{1}{\sqrt[3]{q}} \quad \text{with} \quad q = \frac{L_{\text{calc,km}}}{L_{\text{ref,km}}} = \frac{L_{\text{calc,rot}}}{L_{\text{ref,rot}}}$$

for $q = 1$:
 Calculated service life (here desired service life) $L_{\text{calc,km}} = 1 \times$ reference service life $L_{\text{ref,km}}$
 gives $f_v = 1$

for $q \neq 1$:
 Calculated service life (here desired service life) $L_{\text{calc,km}} = q \times$ reference service life $L_{\text{ref,km}}$
 read off (\rightarrow graph) or calculate f_v

f_v	Load comparison factor
q	Quotient of desired service life divided by reference service life
$L_{\text{calc, km}}$	Calculated service life in km
$L_{\text{ref, km}}$	Reference service life in km $\rightarrow 12$
$L_{\text{calc, rot}}$	Calculated service life in rotations
$L_{\text{ref, rot}}$	Reference service life in rotations $\rightarrow 12$

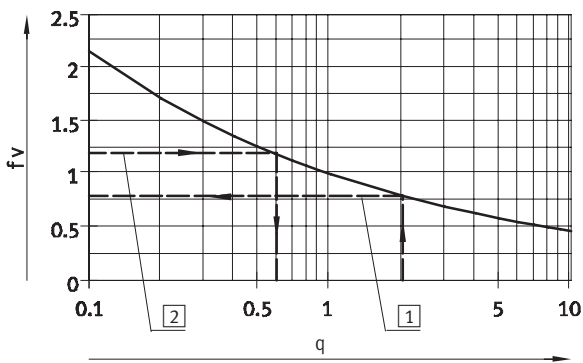

- 1** \rightarrow Example 1
- 2** \rightarrow Example 2

5 Calculation examples

<p>Example 1:</p> <p>EGSK-26-...-2P-H-...</p> <p>$L_{\text{ref,km}} = 1,000 \text{ km}$ $L_{\text{calc,km}} = 2,000 \text{ km}$</p> <p>$q = \frac{2000\text{km}}{1000\text{km}} = 2.0$</p> <p>$f_v = \frac{1}{\sqrt[3]{q}} = 0.79$</p>	<p>Result:</p> <p>A desired service life of 200% of the reference service life means that the permissible total load must be 21% lower.</p>	<p>Example 2:</p> <p>If the total load calculation gives a load comparison factor f_v of 1.2, the mathematical service life is only approx. 60% ($x = 0.6 \rightarrow$ graph) of the reference service life.</p> <p>$q = \frac{1}{f_v^3} = 0.58$</p>
--	--	--

6 Static sizing

Ball screw

$F_{x,\text{stat}} = \text{Max}[F_{x1}, F_{x2}, F_{x3}] \leq \frac{C_{0,\text{KGT}}}{f_s}$	$F_{x,\text{stat}}$	Maximum value of the calculated force load per cycle phase	$C_{0,\text{KGT}}$	Static basic load rating of ball screw $\rightarrow 10$
	$F_{x1/2/3}$	Calculated force load per cycle phase	f_s	Safety factor against static overload $f_s = 1.0 \dots 3.0$

Linear guide

$F_{y,\text{stat}} = \text{Max}[F_{y1}, F_{y2}, F_{y3}] \leq \frac{C_{0,\text{guide}}}{f_s}$	$F_{y/z,\text{stat}}$	Maximum value of the calculated force load per cycle phase	$M_{x1/2/3},$ $M_{y1/2/3},$ $M_{z1/2/3}$	Calculated torque load per cycle phase
$F_{z,\text{stat}} = \text{Max}[F_{z1}, F_{z2}, F_{z3}] \leq \frac{C_{0,\text{guide}}}{f_s}$	$M_{x/y/z,\text{stat}}$	Maximum value of the calculated torque load per cycle phase	$C_{0,\text{guide}}$	
$M_{x,\text{stat}} = \text{Max}[M_{x1}, M_{x2}, M_{x3}] \leq \frac{1}{k_x} \times \frac{C_{0,\text{guide}}}{f_s}$	$F_{y1/2/3},$ $F_{z1/2/3}$	Calculated force load per cycle phase	$k_{x/y/z}$	Torque equivalence factors $\rightarrow 11$
$M_{y,\text{stat}} = \text{Max}[M_{y1}, M_{y2}, M_{y3}] \leq \frac{1}{k_y} \times \frac{C_{0,\text{guide}}}{f_s}$			f_s	Safety factor against static overload $f_s = 1.0 \dots 3.0$
$M_{z,\text{stat}} = \text{Max}[M_{z1}, M_{z2}, M_{z3}] \leq \frac{1}{k_z} \times \frac{C_{0,\text{guide}}}{f_s}$				

Electric slides EGSK

Technical data

Dimensions

Download CAD Data → www.festo.com/us/cad

EGSK-15

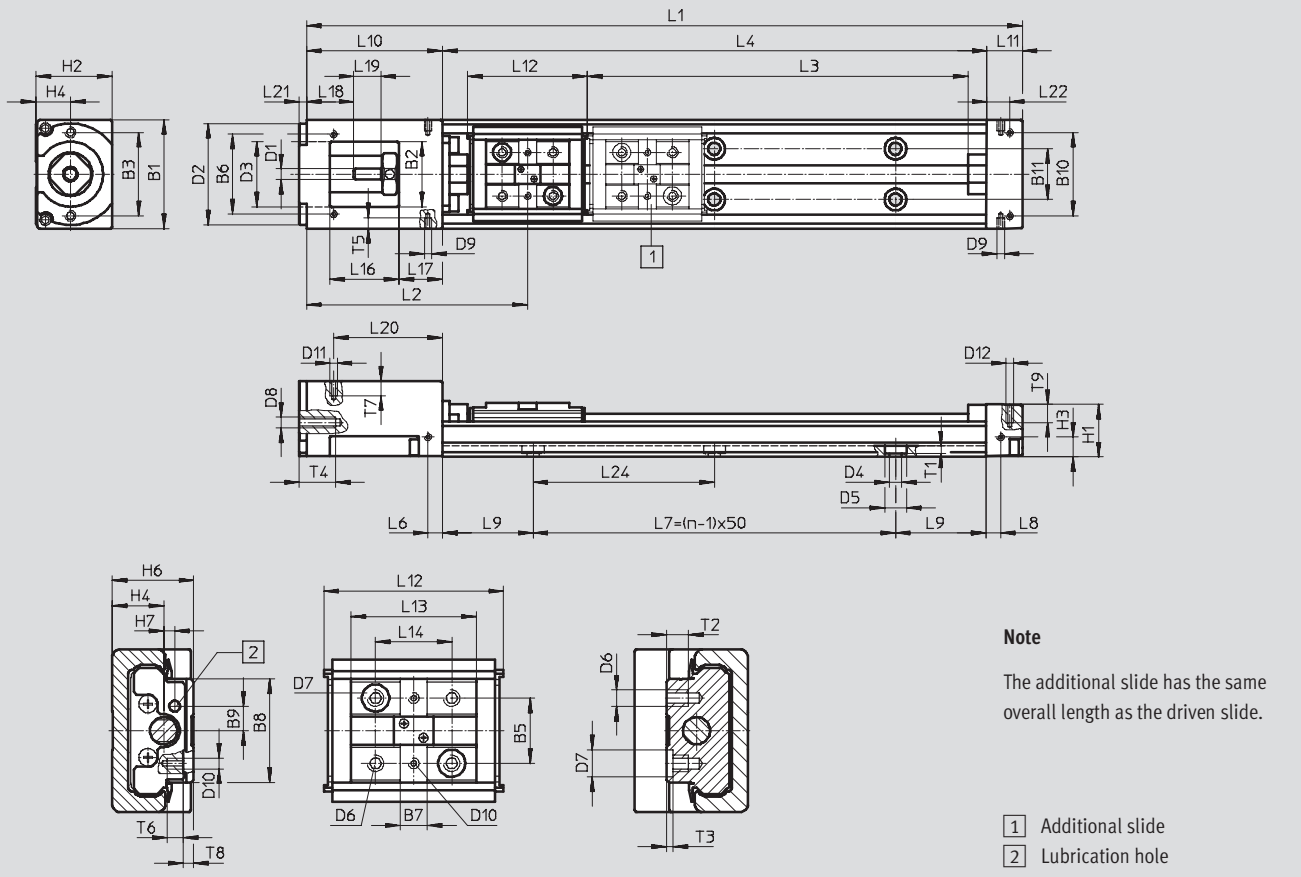

Note

The additional slide has the same overall length as the driven slide.

- 1 Additional slide
- 2 Lubrication hole

Size	Stroke	L1	L3 +4	L4	L7	L9	n
15	25	122.5	30	75	50	12.5	2
	50	147.5	55	100	50	25	2
	75	172.5	80	125	100	12.5	3
	100	197.5	105	150	100	25	3

Size	B1	B2	B3	B5	B6	B7	B8	B9	B11	B10	D1	D2	D3	D4	D5	D6	D7	D8
15	30	18	±0.1 23	±0.02 12	±0.1 22	5	19	4.5	14	±0.1 23	h6 3	g7 28	∅ 18	∅ 3.4	∅ 6	M3	∅ 5	M3

Size	D9	D10	D11	D12	H1	H2	H3	H4	H6	H7	L2	L6	L8	L10	L11	L12	L13	L14
15	M2	M2	M2	M2	14.5	20.9	5.5	9.5	15	2	60.3	4	4	37.5	10	33	23	14

Size	L16	L17	L18	L19	L20	L21	L22	L24	T1	T2	T3	T4	T5	T6	T7	T8	T9
15	19	12	13	7.5	±0.1 30	2	±0.1 6.5	50	2	4	+0.1 1.2	10	3	3	4	1.9	5

Electric slides EGSK

Technical data

Dimensions

Download CAD Data → www.festo.com/us/cad

EGSK-20/26

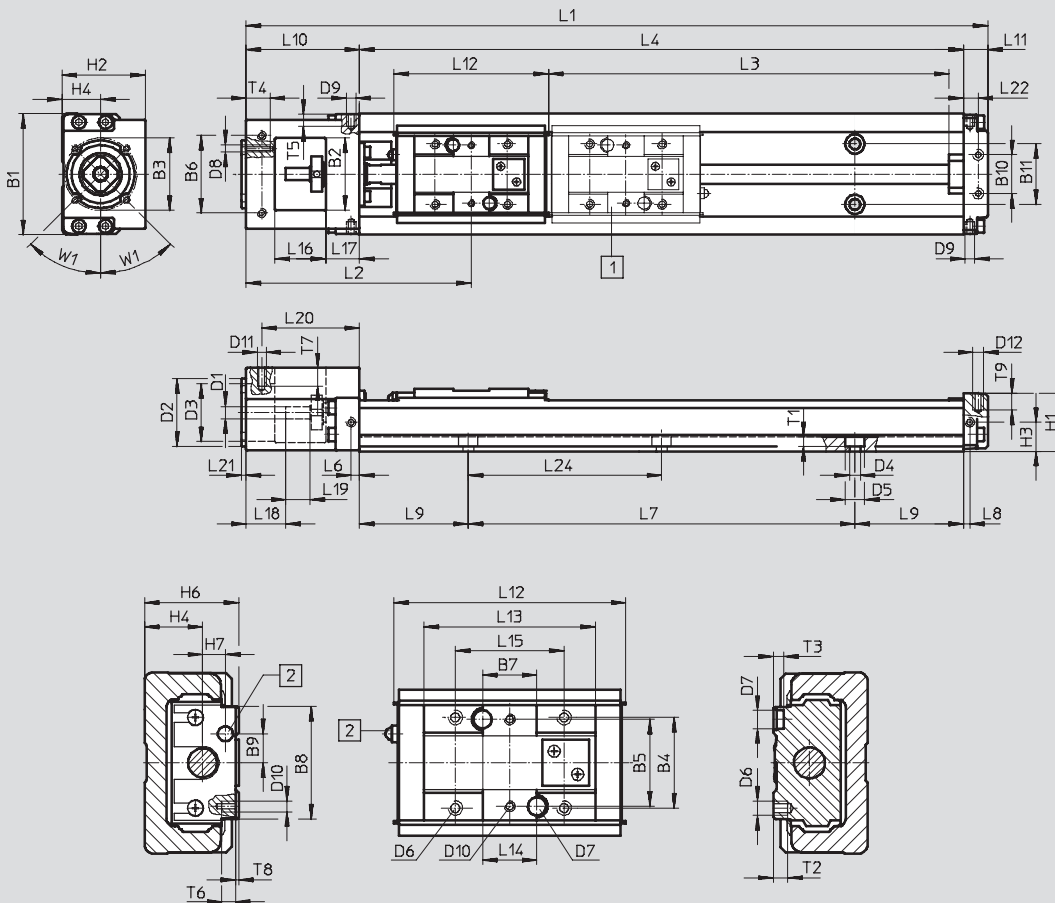

Note

The additional slide has the same overall length as the driven slide.

- 1 Additional slide
- 2 Lubrication nipple

Size	Stroke	L1	L3 +4	L4	L7= (n-1)x60	L9	n
20	25	152	40	100	60	20	2
	75	202	90	150	120	15	3
	125	252	140	200	120	40	3

Size	Stroke	L1	L3 +4	L4	L7= (n-1)x80	L9	n
26	50	207	67	150	80	35	2
	100	257	117	200	160	20	3
	150	307	167	250	160	45	3
	200	357	217	300	240	30	4

Electric slides EGSK

Technical data

Size	B1	B2	B3 ∅	B4	B5 ±0.02	B6 ±0.1	B7	B8	B9	B10 ±0.1	B11	D1 ∅ h7	D2 ∅ g7	D3 ∅
20	40	22	30	18	18	29	10	23	5	18	18	4	28	22
26	50	30	30	25	24	32	15	31	8	16	25	5	28	24

Size	D4 ∅	D5 ∅	D6	D7 ∅ H7	D8	D9	D10	D11	D12	H1	H2	H3	H4	H6
20	3.4	6.5	M3	2	M3	M2.6	M2	M2.5	M2.5	19	28	10	13	20
26	4.5	8	M4	5	M3	M2.6	M3	M2.5	M3	24	34.5	12	16	26

Size	H7	L2	L6	L8	L10	L11	L12	L13	L14 ¹⁾ ±0.02	L15	L16	L17	L18	L19
20	3.4	72.5	3.5	2.5	42	10	46	33.2	10	20	18	12	16	8
26	6	91	3.5	2.5	47	10	64	47.4	15	30	21	14	16.5	10

Size	L20 ±0.1	L21	L22 ±0.1	L24	T1	T2	T3	T4	T5	T6	T7	T8	T9	W1
20	34.5	2	6.5	60	3	4.5	3	10	4	5	5	0.9	5	45°
26	40.5	2	6	80	4	6.5	3	10	4	6	5	0.9	6	45°

1) Distance between the locating holes

Electric slides EGSK

Technical data

Dimensions

Download CAD Data → www.festo.com/us/cad

EGSK-33/46

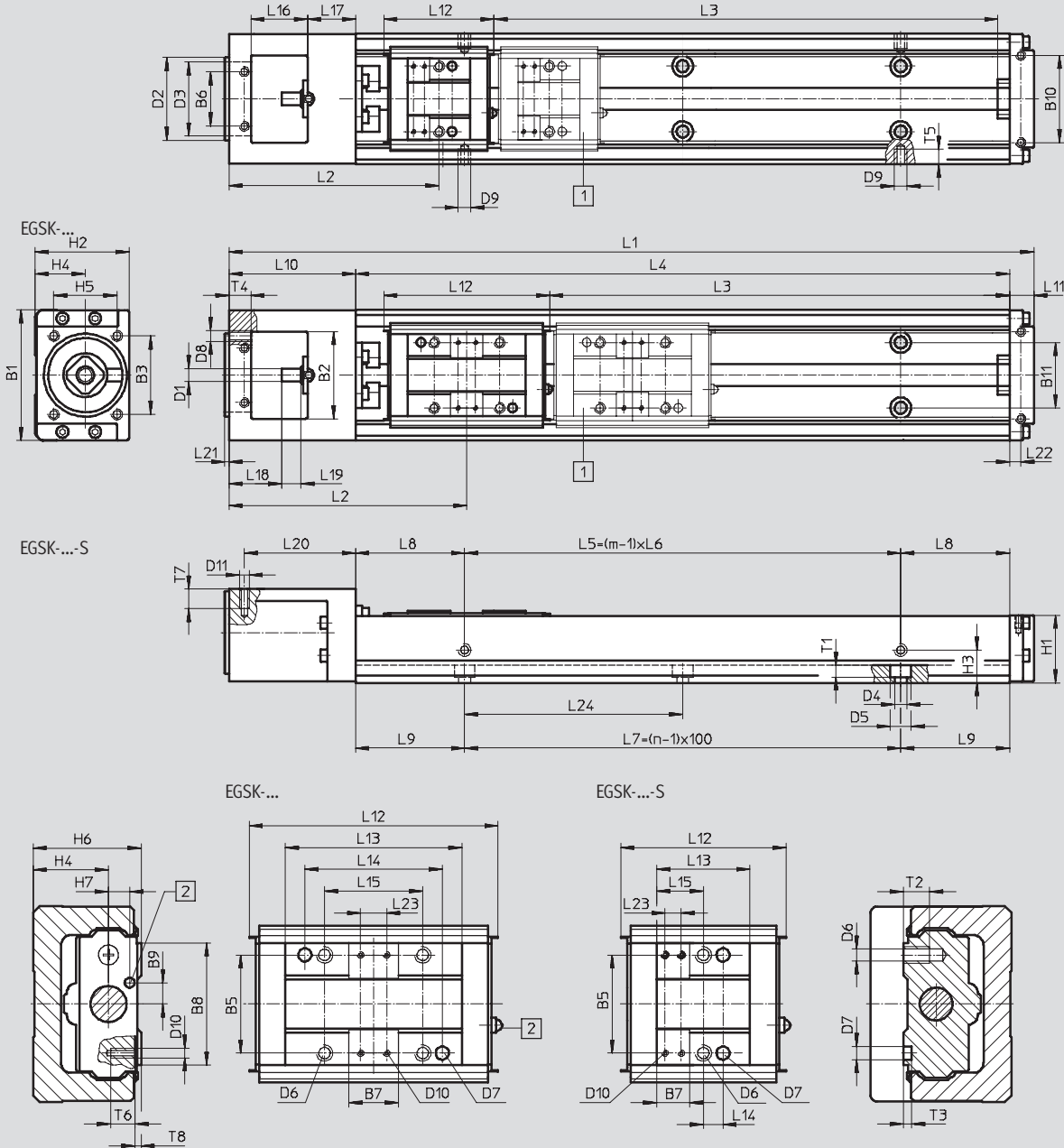

Note

The additional slide has the same overall length as the driven slide.

- 1 Additional slide
- 2 Lubrication nipple

Electric slides EGSK

Technical data

FESTO

Size	Stroke	L1	L3 +4		L4	L5	L6	L7	L8	m	n
				S							
33	100	269	110	135	200	100	100	100	50	2	2
	200	369	210	235	300	200	200	200	50	2	3
	300	469	310	335	400	200	200	300	100	2	4
	400	569	410	435	500	400	200	400	50	3	5
	500	669	510	535	600	400	200	500	100	3	6
	600	769	610	635	700	600	200	600	50	4	7

Size	Stroke	L1	L3 +4		L4	L5	L6	L7	L8	m	n
				S							
46	200	425.5	206	244	340	200	200	200	70	2	3
	300	525.5	306	344	440	400	200	300	20	3	4
	400	625.5	406	444	540	400	200	400	70	3	5
	500	725.5	506	544	640	600	200	500	20	4	6
	600	825.5	606	644	740	600	200	600	70	4	7
	800	1,025.5	806	844	940	800	200	800	70	5	9

Size	B1	B2	B3 ±0.1	B5 ±0.04	B6 ±0.1	B7	B8	B9	B10 ±0.1	B11	D1 ∅ h7	D2 ∅ g7	D3 ∅	D4 ∅	D5 ∅
33	60	40	36	30	25	15	37.4	6.5	40	30	6	38	34	5.5	9.5
46	86	48	36	46	42	15	54.4	10	58	46	8	38	34	6.6	11

Size	D6	D7 ∅ H7	D8	D9	D10	D11	H1	H2	H3	H4	H5 ±0.1	H6	H7	L2	
															S
33	M5	4	M5	M2.6	M2	M3	31	43	15	23	29	33	6.5	105	92.3
46	M6	5	M5	M2.6	M2	M4	43.5	60	28	32	29	46	9	142.5	123.8

Size	L9	L10	L11	L12		L13		L14		L15		L16	L17	L18	L19
					S		S	±0.04	S ±0.1		S				
33	50	58	11	76	50.5	54	28.5	42	6	30	14.25	26	22	24	9
46	70	72.5	13	110	72.5	81	43.5	28	11	46	21.75	33.5	25	21.5	18

Size	L20 ±0.1	L21	L22 ±0.1	L23		L24	T1	T2	T3	T4	T5	T6	T7	T8
					S									
33	51	2	5	8	5	100	5.4	8	2.5	10	4	5	6	1
46	65.5	2	3.5	8	8	100	6.5	12	2.5	10	4	5	8	1

Electric slides EGSK

Technical data

Ordering data – Electric slides with standard slide					
Size	Stroke [mm]	Part No.	Type	Part No.	Type
		Spindle pitch 1 mm		Spindle pitch 6 mm	
20	25	562758	EGSK-20-25-1P	562761	EGSK-20-25-6P
	75	562759	EGSK-20-75-1P	562762	EGSK-20-75-6P
	125	562760	EGSK-20-125-1P	562763	EGSK-20-125-6P

Size	Stroke [mm]	Part No.	Type	Part No.	Type
		Spindle pitch 2 mm		Spindle pitch 6 mm	
26	50	562764	EGSK-26-50-2P	562768	EGSK-26-50-6P
	100	562765	EGSK-26-100-2P	562769	EGSK-26-100-6P
	150	562766	EGSK-26-150-2P	562770	EGSK-26-150-6P
	200	562767	EGSK-26-200-2P	562771	EGSK-26-200-6P

Size	Stroke [mm]	Part No.	Type	Part No.	Type
		Spindle pitch 6 mm		Spindle pitch 10 mm	
33	100	562772	EGSK-33-100-6P	562778	EGSK-33-100-10P
	200	562773	EGSK-33-200-6P	562779	EGSK-33-200-10P
	300	562774	EGSK-33-300-6P	562780	EGSK-33-300-10P
	400	562775	EGSK-33-400-6P	562781	EGSK-33-400-10P
	500	562776	EGSK-33-500-6P	562782	EGSK-33-500-10P
	600	562777	EGSK-33-600-6P	562783	EGSK-33-600-10P

Size	Stroke [mm]	Part No.	Type	Part No.	Type
		Spindle pitch 10 mm		Spindle pitch 20 mm	
46	200	562784	EGSK-46-200-10P	562790	EGSK-46-200-20P
	300	562785	EGSK-46-300-10P	562791	EGSK-46-300-20P
	400	562786	EGSK-46-400-10P	562792	EGSK-46-400-20P
	500	562787	EGSK-46-500-10P	562793	EGSK-46-500-20P
	600	562788	EGSK-46-600-10P	562794	EGSK-46-600-20P
	800	562789	EGSK-46-800-10P	562795	EGSK-46-800-20P

Electric slides EGSK

Ordering data – Modular products

Ordering table									
Size	15	20	26	33	46	Conditions	Code	Enter code	
M Module No.	562749	562750	562751	562752	562753				
Drive function	Electric slide drive							EGSK	EGSK
Size	15	20	26	33	46		-...	-...	
Standard stroke for standard slide [mm]	25	-		-			-25	-...	
	50	-	50	-	-		-50	-...	
	75	-		-			-75	-...	
	100	-	100	-	-		-100	-...	
	-	125	-		-		-125	-...	
	-	-		150	-	-		-150	-...
	-	-		200	-		-200	-...	
	-	-			300	-	-300	-...	
	-	-			400	-	-400	-...	
	-	-			500	-	-500	-...	
	-	-			600	-	-600	-...	
	-	-				800	-	-800	-...
	Standard stroke for slide, short [mm]	-	-		130	-	-130	-...	
-		-		230	-	-230	-...		
-		-			240	-	-240	-...	
-		-			330	-	-330	-...	
-		-			340	-	-340	-...	
-		-			430	-	-430	-...	
-		-			440	-	-440	-...	
-		-			530	-	-530	-...	
-		-			540	-	-540	-...	
-		-			630	-	-630	-...	
-		-			640	-	-640	-...	
Spindle pitch [mm]	1	-		-			-1P	-...	
	2	-	2	-	-		-2P	-...	
	-	6	-		-		-6P	-...	
	-	-	-	10	-		-10P	-...	
	-	-			20	-	-20P	-...	
O Accuracy	-	Standard accuracy						-	-...
	-	Greater accuracy						-H	-...
	-	Precision accuracy					1	-P	-...
Slide design	Standard slide						-	-...	
	-			Slide, short			-S	-...	
Additional slide	No additional slide						-	-...	
	Additional slide (additional slide Z in combination with slide design S also results in a short slide)					2	-Z	-...	

- 1 P** With size 33 not in combination with stroke for standard slide 600 and stroke for slide, short 630
 With size 46 not in combination with stroke for standard slide 800 and stroke for slide, short 840
- 2 Z** With size 15 not in combination with stroke for standard slide 25 and stroke for standard slide 50
 With size 20 not in combination with stroke for standard slide 25
 With size 26 not in combination with stroke for standard slide 50
 With size 33 not in combination with stroke for standard slide 100

Transfer order code

	EGSK	-		-		-		-		-		-	
--	-------------	---	--	---	--	---	--	---	--	---	--	---	--

Electric slides EGSP

Type codes

		EGSP	-	26	-	150	-	2P	-	H	-		-	Z
Type														
EGSP	Electric slide													
Size														
Stroke [mm]														
Spindle pitch														
Accuracy														
-	Standard													
H	High accuracy													
P	Precision design													
Slide design														
-	Standard slide													
S	Slide, short													
Additional slide														
-	No additional slide													
Z	Additional slide													

Electric slides EGSP

Technical data

Function

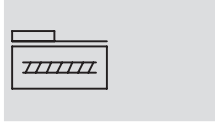

- Ø - Size
20 ... 46
- | - Stroke length
25 ... 840 mm



General technical data										
Size		20		26		33			46	
Spindle pitch		1	6	2	6	6	10	20	10	20
		Code ¹⁾								
Constructional design		Electromechanical linear axis with recirculating ball bearing spindle								
Guide		Recirculating ball bearing guide								
Installation position		Any								
Type of mounting for effective load		Female thread Locating pin								
Working stroke ²⁾	- [mm]	25 ... 125		50 ... 200		100 ... 600			200 ... 800	
	S [mm]	-		-		130 ... 630			240 ... 840	
Max. feed force	-/H ³⁾ [N]	69	72	168	164	370	227	165	365	267
F _{x,max}	P ⁴⁾ [N]	87	112	212	212	466	286	208	460	337
Max. driving torque	-/H ³⁾ [Ncm]	1.1	6.9	5.3	16	35	36	53	58	85
M _{Driving,max}	P ⁴⁾ [Ncm]	1.4	11	6.7	20	45	46	66	73	107
No-load torque	-/H [Ncm]	0.5	0.5	1.5	1.5	7	7	7	10	10
M _{No-load}	P [Ncm]	1.2	1.2	4.0	4.0	15	15	15	17	17
Max. rotational speed ⁵⁾	[1/min]	6,000	6,000	6,000	6,000	6,000	6,000	6,000	6,000	6,000
Max. speed ⁵⁾	-/H [m/s]	0.1	0.6	0.2	0.6	0.6	1	2	1	2
	P [m/s]	0.1	0.6	0.2	0.6	0.6	1	2	1	2
Max. acceleration	[m/s ²]	10		10		20			20	
Homing		Inductive proximity sensor SIES-8M								

1) Variant code → 22

2) Maximum travel distance → 31

In combination with an additional slide, the working stroke is reduced by the length of the additional slide and the distance between the two slides

3) Loads are based on a service life specification of 5×10^8 rotations

4) Loads are based on a service life specification of 2.5×10^8 rotations

5) Reduced speeds with sizes 33 and 46 with long strokes → 25

Operating and environmental conditions		
Ambient temperature	[°C]	0 ... +40
Relative air humidity	[%]	0 ... 95 (non-condensing)

Weight [kg]					
Size		20	26	33	46
		Code ¹⁾			
Basic weight with 0 mm stroke ²⁾	-	0.38	0.78	1.38	3.60
	S	-	-	1.30	3.30
Additional weight per 100 mm stroke	-	0.27	0.42	0.72	1.40
Moving load	-	0.07	0.15	0.31	0.91
	S	-	-	0.17	0.57
Additional slide Z	-	0.07	0.15	0.31	0.91
	S	-	-	0.17	0.57

1) Variant code → 22

2) Including slide, without additional slide

Electric slides EGSP

Technical data

Accuracy data [μm]				20		26		33		46	
Size	Stroke	Code ¹⁾									
Repetition accuracy ²⁾		–	±10	±10	±10	±10	±10	±10	±10	±10	±10
		H	±5	±5	±5	±5	±5	±5	±5	±5	±5
		P	±3	±3	±3	±3	±3	±3	±3	±3	±3
Running parallelism	25 ... 340	H	25	25	25	25	25	25	25	25	35
	400 ... 540	H	–	–	–	–	–	–	–	–	35
	600 ... 640	H	–	–	–	–	–	–	–	–	40
	800 ... 840	H	–	–	–	–	–	–	–	–	50
	25 ... 340	P	10	10	10	10	10	10	10	10	15
	400 ... 540	P	–	–	–	–	–	–	–	–	15
	600 ... 640	P	–	–	–	–	–	–	–	–	20
Max. reversing play		–	20	20	20	20	20	20	20	20	20
		H	10	10	10	10	10	10	10	10	20
		P	3	3	3	3	3	3	3	3	3

1) Variant code → 22

2) The repetition accuracy that can be achieved with a motor/axis system is also influenced by the angle resolution of the motor and the chosen control parameters. The specified repetition accuracy cannot, therefore, be achieved with all motors.

Materials

Sectional view

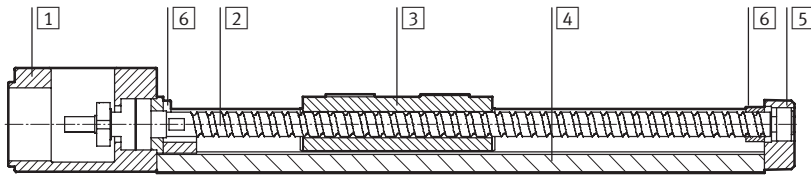

Electric slide		
1	Drive cover	Die-cast aluminium, coated
2	Spindle	Steel
3	Slide	Steel
4	Profile	High-alloy steel
5	End cap	Die-cast aluminium, coated
6	Buffer	Ethylene vinyl acetate copolymer
Note on materials		RoHS-compliant
		Contains PWIS (paint-wetting impairment substances)

Mass moment of inertia											
Size			20		26		33			46	
Spindle pitch	Code ¹⁾		1	6	2	6	6	10	20	10	20
J_0		[kg mm ²]	0.087	0.143	0.355	0.479	2.72	3.22	5.57	8.51	15.42
	S	[kg mm ²]	–	–	–	–	1.93	2.21	–	6.10	10.43
J_S per 100 mm stroke		[kg mm ² /100 mm]	0.099		0.314		0.766			3.877	
J_L per kg effective load		[kg mm ² /kg]	0.03	0.91	0.10	0.91	0.91	2.53	10.13	2.53	10.13
J_W per additional slide		[kg mm ²]	0.002	0.058	0.016	0.14	0.28	0.79	3.14	2.31	9.22
	S	[kg mm ²]	–	–	–	–	0.16	0.43	–	1.44	5.78

1) Variant code → 22

The mass moment of inertia J_A of the entire axis is calculated as follows:

$$J_A = J_0 + J_W + J_S \times \text{working stroke} + J_L \times m_{\text{effective load}}$$

Electric slides EGSP

Technical data

Speed v, rotational speed n as a function of working stroke l

EGSP-33-...-6P

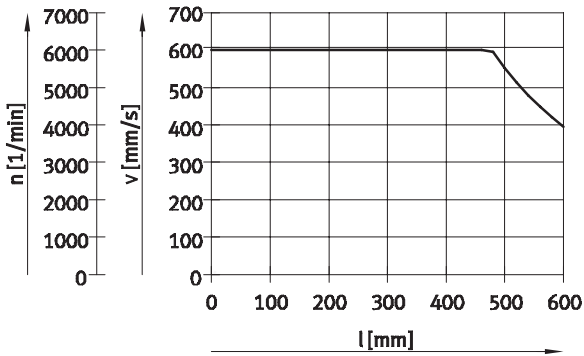

EGSP-33-...-10P

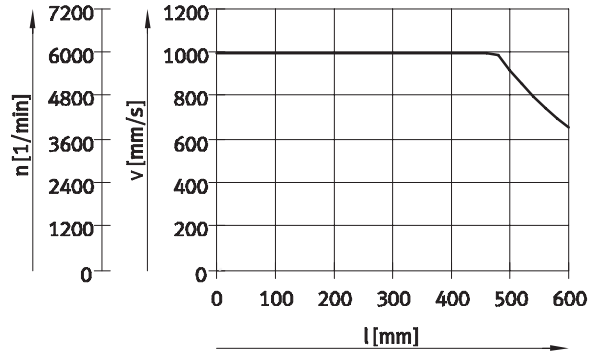

EGSP-33-...-20P

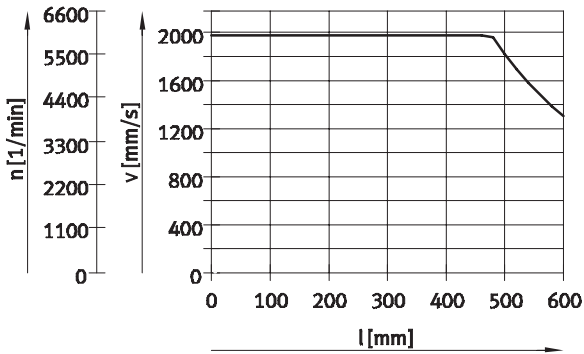

EGSP-46-...-10P

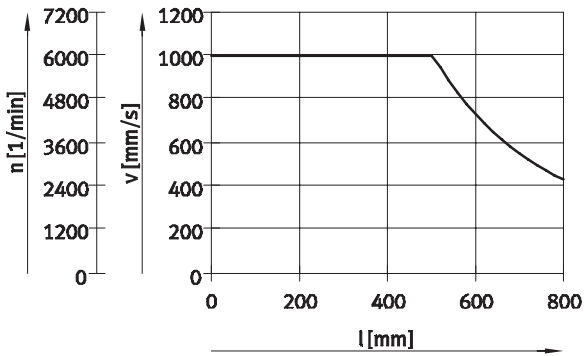

EGSP-46-...-20P

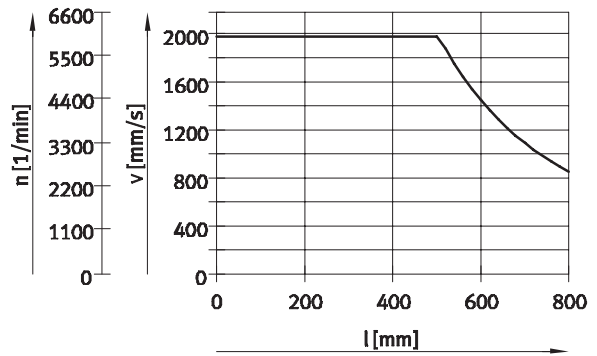

2nd moment of area

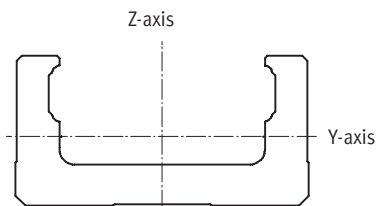

Size		20	26	33	46
ly	[mm ⁴]	6,000	16,600	53,500	205,000
lz	[mm ⁴]	61,400	148,000	352,000	1,450,000

Electric slides EGSP

Technical data

Characteristic load values

The indicated forces and torques refer to the centre axis of the spindle.
The coordinate zero point is the point where the centre of the guide and the longitudinal centre of the slide intersect.

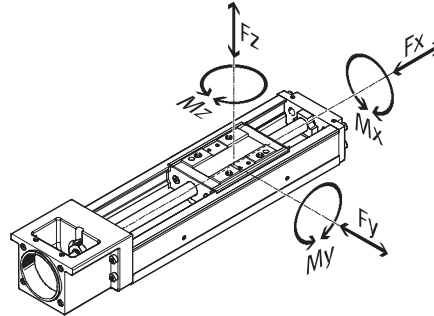

Note

PositioningDrives
sizing software
www.festo.com

Permissible dynamic forces and torques ¹⁾			20		26		33			46		
Size			1	6	2	6	6	10	20	10	20	
Spindle pitch	Code ²⁾											
F _y max., F _z max.	-/H ³⁾	-	[N]	2,325	1,279	3,991	2,767	3,619	3,052	2,422	7,092	5,629
	P ⁴⁾	-	[N]	2,929	1,612	5,028	3,486	4,559	3,845	3,052	8,935	7,092
	-/H ³⁾	S	[N]	-	-	-	-	2,405	2,029	-	5,099	4,047
	P ⁴⁾	S	[N]	-	-	-	-	3,031	2,556	-	6,424	5,099
M _x max.	-/H ³⁾	-	[Nm]	28.8	15.9	64.7	44.8	71.7	60.4	48.0	205	163
	P ⁴⁾	-	[Nm]	36.3	20.0	81.5	56.5	90.3	76.1	60.4	258	205
	-/H ³⁾	S	[Nm]	-	-	-	-	47.6	40.2	-	147	117
	P ⁴⁾	S	[Nm]	-	-	-	-	60.0	50.6	-	186	147
M _y max., M _z max.	-/H ³⁾	-	[Nm]	9.9	5.5	25.1	17.4	25.5	21.5	17.1	74.6	59.2
	P ⁴⁾	-	[Nm]	12.5	6.9	31.6	21.9	32.1	27.1	21.5	94.0	74.6
	-/H ³⁾	S	[Nm]	-	-	-	-	10.1	8.5	-	34.9	27.7
	P ⁴⁾	S	[Nm]	-	-	-	-	12.7	10.7	-	44.0	34.9

- 1) Calculated with a speed-dependent load factor f_w of 1.2
- 2) Variant code → 22
- 3) Loads are based on a service life specification of 5×10^8 rotations and a load factor f_w of 1.2
- 4) Loads are based on a service life specification of 2.5×10^8 rotations and a load factor f_w of 1.2

Basic load ratings			20		26		33			46	
Size			1	6	2	6	6	10	20	10	20
Spindle pitch	Code ¹⁾										
Ball screw											
Static C ₀ ball screw	-/H	[N]	1,170	1,450	4,020	3,510	6,290	3,780	3,770	6,990	7,040
	P	[N]	1,170	1,600	4,020	3,900	6,290	3,780	3,770	6,990	7,040
Dynamic c _{dyn} ball screw	-/H ²⁾	[N]	660	860	2,350	1,950	4,400	2,700	2,620	4,350	4,240
	P ²⁾	[N]	660	1,060	2,350	2,390	4,400	2,700	2,620	4,350	4,240
Fixed bearing											
Static C ₀ bearing		[N]	735		1,230		2,700			3,330	
Dynamic c _{dyn} bearing ²⁾		[N]	1,150		2,000		6,250			6,700	

- 1) Variant code → 22
- 2) Dynamic basic load ratings are based on a basic service life of 10^6 rotations

Electric slides EGSP

Technical data

FESTO

Basic load ratings											
Size			20		26		33			46	
Spindle pitch			1	6	2	6	6	10	20	10	20
Code ¹⁾											
Linear guide											
Static $C_{0,guide}$	-	[N]	8,030		16,500		20,400			45,900	
	S	[N]	-		-		11,500			-	
Dynamic $c_{dyn,guide}$ ²⁾	-	[N]	4,770		10,318		13,493			31,351	
	S	[N]	-		-		8,969			-	
Torque equivalence factors											
k_x	-	[1/m]	80.7		61.7		50.5			34.6	
	S	[1/m]	-		-		50.5			-	
k_y, k_z	-	[1/m]	234.4		159.1		142			95.1	
	S	[1/m]	-		-		239.1			-	

1) Variant code → 22

2) Dynamic basic load ratings are based on a basic service life of 100 km

Speed-dependent load factor f_w

$f_w = 1.0 \dots 1.2$ ($v \leq 0.25$ m/s)

$f_w = 1.2 \dots 1.5$ (0.25 m/s $\leq v \leq 1.0$ m/s)

$f_w = 1.5 \dots 2.0$ (1.0 m/s $\leq v \leq 2.0$ m/s)

$f_w = 2.0 \dots 3.5$ ($v \geq 2.0$ m/s)

Calculation of the maximum feed force F_x

$$F_{x,max} = \frac{1}{f_w} \times \frac{\text{Min}[C_{dyn,KGT}; C_{dyn,bearing}]}{\sqrt[3]{\frac{L_{ref,rot}}{10^6}}}$$

Calculation of the maximum forces $F_{y/z}$ and torques $M_{x/y/z}$

$$F_{y/z,max} = \frac{1}{f_w} \times \frac{C_{dyn,guide}}{\sqrt[3]{\frac{L_{ref,km}}{100km}}}$$

$$M_{x/y/z,max} = \frac{1}{k_{x/y/z}} \times \frac{1}{f_w} \times \frac{C_{dyn,guide}}{\sqrt[3]{\frac{L_{ref,km}}{100km}}}$$

Electric slides EGSP

Technical data

Calculation of the service life

Size		20	26		33			46		
Spindle pitch P		1	6	2	6	6	10	20	10	20
	Code ¹⁾									
Reference service life	-/H	5 x 10 ⁸								
in rotations, L _{ref,rot}	P	2.5 x 10 ⁸								
Reference service life	-/H [km]	500	3,000	1,000	3,000	3,000	5,000	10,000	5,000	10,000
in kilometres, L _{ref,km}	P [km]	250	1,500	500	1,500	1,500	2,500	5,000	2,500	5,000

1) Variant code → 22

1 Representation of the loads

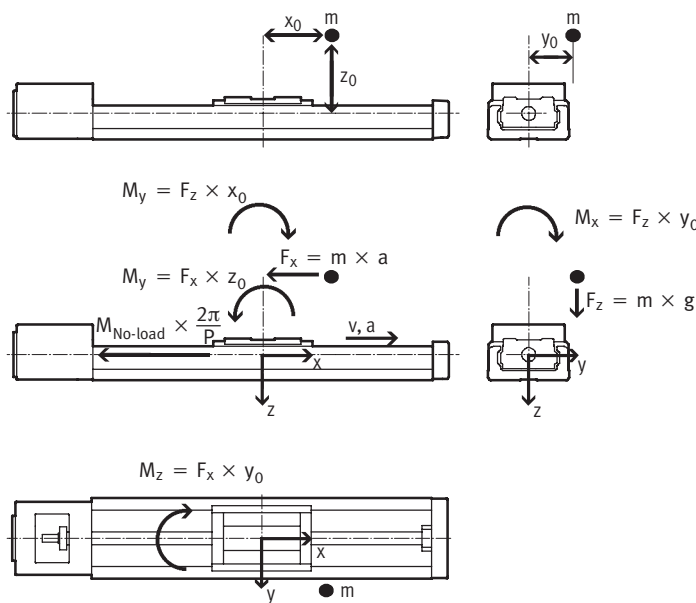

2 Determination of the loads over the travel cycle

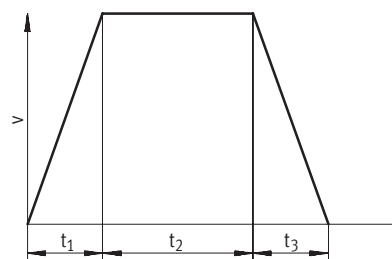

$$q_1 = \frac{t_1}{t_{tot}} \quad q_2 = \frac{t_2}{t_{tot}} \quad q_3 = \frac{t_3}{t_{tot}}$$

$$t_{tot} = t_1 + t_2 + t_3$$

v	Speed
t ₁	Acceleration time
t ₂	Constant travel time
t ₃	Deceleration time
q _{1/2/3}	Relative time of the cycle phases
t _{tot}	Cycle time

Ball screw

For t₁: $F_{x1} = - (m \times a) - (M_{No-load} \times \frac{2\pi}{P})$

For t₂: $F_{x2} = - (M_{No-load} \times \frac{2\pi}{P})$

For t₃: $F_{x3} = m \times a - (M_{No-load} \times \frac{2\pi}{P})$

$$F_{x,dyn} = \sqrt[3]{q_1 \times |F_{x1}|^3 + q_2 \times |F_{x2}|^3 + q_3 \times |F_{x3}|^3}$$

F _{x1/2/3}	Calculated force load per cycle phase
F _{x,dyn}	Calculated average force load
m	Effective load (centre of gravity)
a	Acceleration
M _{No-load}	No-load torque → 23
P	Spindle pitch → 23
q _{1/2/3}	Relative time of the cycle phases

Electric slides EGSP

Technical data

FESTO

2 Determination of the loads over the travel cycle		
Linear guide		
<p>For t₁: a →, v →</p> $F_{y1} = 0$ $F_{z1} = m \times g$ $M_{x1} = F_z \times y_0 = m \times g \times y_0$ $M_{y1} = -F_z \times x_0 + F_x \times z_0 = -m \times g \times x_0 + m \times a \times z_0$ $M_{z1} = F_x \times y_0 = m \times a \times y_0$	$F_{y1/2/3}$ $F_{z1/2/3}$ $M_{x1/2/3}$ $M_{y1/2/3}$ $M_{z1/2/3}$ $F_{y/z,dyn}$ $M_{x/y/z,dyn}$	<p>Calculated force load per cycle phase</p> <p>Calculated torque load per cycle phase</p> <p>Calculated average force load</p> <p>Calculated average torque load</p>
<p>For t₂: a = 0, v →</p> $F_{y2} = 0$ $F_{z2} = m \times g$ $M_{x2} = F_z \times y_0 = m \times g \times y_0$ $M_{y2} = -F_z \times x_0 = -m \times g \times x_0$ $M_{z2} = 0$	m g a x_0, y_0, z_0	<p>Effective load (centre of gravity)</p> <p>Gravitational acceleration</p> <p>Acceleration</p> <p>Distances between the centre of gravity of the effective load and the slide centre point</p>
<p>For t₃: a ←, v →</p> $F_{y3} = 0$ $F_{z3} = m \times g$ $M_{x3} = F_z \times y_0 = m \times g \times y_0$ $M_{y3} = -F_z \times x_0 - F_x \times z_0 = -m \times g \times x_0 - m \times a \times z_0$ $M_{z3} = -F_x \times y_0 = -m \times a \times y_0$	$q_{1/2/3}$	<p>Relative time of the cycle phases</p>
$F_{y,dyn} = \sqrt[3]{q_1 \times F_{y1} ^3 + q_2 \times F_{y2} ^3 + q_3 \times F_{y3} ^3}$ $F_{z,dyn} = \sqrt[3]{q_1 \times F_{z1} ^3 + q_2 \times F_{z2} ^3 + q_3 \times F_{z3} ^3}$ $M_{x,dyn} = \sqrt[3]{q_1 \times M_{x1} ^3 + q_2 \times M_{x2} ^3 + q_3 \times M_{x3} ^3}$ $M_{y,dyn} = \sqrt[3]{q_1 \times M_{y1} ^3 + q_2 \times M_{y2} ^3 + q_3 \times M_{y3} ^3}$ $M_{z,dyn} = \sqrt[3]{q_1 \times M_{z1} ^3 + q_2 \times M_{z2} ^3 + q_3 \times M_{z3} ^3}$		
3 Total load		
Ball screw		
$\frac{ F_{x,dyn} }{F_{x,max}} \leq f_v$	$F_{x,dyn}$ $F_{x,max}$ f_v	<p>Calculated average force load</p> <p>Max. permissible force load → 23</p> <p>Load comparison factor → 30</p>
Linear guide		
$\frac{ F_{y,dyn} }{F_{y,max}} + \frac{ F_{z,dyn} }{F_{z,max}} + \frac{ M_{x,dyn} }{M_{x,max}} + \frac{ M_{y,dyn} }{M_{y,max}} + \frac{ M_{z,dyn} }{M_{z,max}} \leq f_v$	$F_{y/z,dyn}$ $F_{y/z,max}$ $M_{x/y/z,dyn}$ $M_{x/y/z,max}$ f_v	<p>Calculated average force load</p> <p>Max. permissible force load → 26</p> <p>Calculated average torque load</p> <p>Max. permissible torque load → 26</p> <p>Load comparison factor → 30</p>

Electric slides EGSP

Technical data

4 Determination of the load comparison factor f_v

$$f_v = \frac{1}{\sqrt[3]{q}} \quad \text{with} \quad q = \frac{L_{\text{calc,km}}}{L_{\text{ref,km}}} = \frac{L_{\text{calc,rot}}}{L_{\text{ref,rot}}}$$

for $q = 1$:

Calculated service life (here desired service life) $L_{\text{calc,km}} = 1 \times$ reference service life $L_{\text{ref,km}}$ gives $f_v = 1$

for $q \neq 1$:

Calculated service life (here desired service life) $L_{\text{calc,km}} = q \times$ reference service life $L_{\text{ref,km}}$ read off (\rightarrow graph) or calculate f_v

f_v	Load comparison factor
q	Quotient of desired service life divided by reference service life
$L_{\text{calc, km}}$	Calculated service life in km
$L_{\text{ref, km}}$	Reference service life in km $\rightarrow 28$
$L_{\text{calc, rot}}$	Calculated service life in rotations
$L_{\text{ref, rot}}$	Reference service life in rotations $\rightarrow 28$

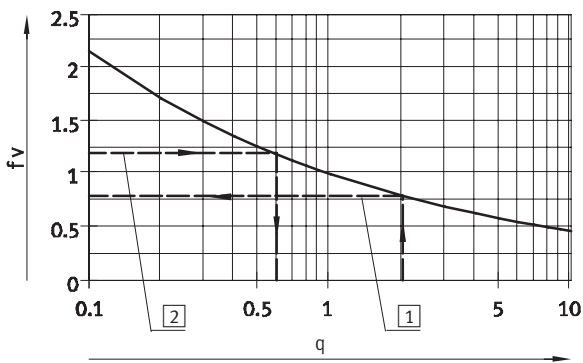

- 1** \rightarrow Example 1
- 2** \rightarrow Example 2

5 Calculation examples

Example 1:

EGSP-26-...-2P-H-...
 $L_{\text{ref,km}} = 1,000 \text{ km}$
 $L_{\text{calc,km}} = 2,000 \text{ km}$
 $q = \frac{2000\text{km}}{1000\text{km}} = 2.0$
 $f_v = \frac{1}{\sqrt[3]{q}} = 0.79$

Result:
 A desired service life of 200% of the reference service life means that the permissible total load must be 21% lower.

Example 2:

If the total load calculation gives a load comparison factor f_v of 1.2, the mathematical service life is only approx. 60% ($x = 0.6 \rightarrow$ graph) of the reference service life.

$$q = \frac{1}{f_v^3} = 0.58$$

6 Static sizing

Ball screw

$$F_{x,\text{stat}} = \text{Max}[F_{x1}, F_{x2}, F_{x3}] \leq \frac{C_{0,\text{KGT}}}{f_s}$$

$F_{x,\text{stat}}$	Maximum value of the calculated force load per cycle phase
$F_{x1/2/3}$	Calculated force load per cycle phase

$C_{0,\text{KGT}}$	Static basic load rating of ball screw $\rightarrow 26$
f_s	Safety factor against static overload $f_s = 1.0 \dots 3.0$

Linear guide

$$F_{y,\text{stat}} = \text{Max}[F_{y1}, F_{y2}, F_{y3}] \leq \frac{C_{0,\text{guide}}}{f_s}$$

$$F_{z,\text{stat}} = \text{Max}[F_{z1}, F_{z2}, F_{z3}] \leq \frac{C_{0,\text{guide}}}{f_s}$$

$$M_{x,\text{stat}} = \text{Max}[M_{x1}, M_{x2}, M_{x3}] \leq \frac{1}{k_x} \times \frac{C_{0,\text{guide}}}{f_s}$$

$$M_{y,\text{stat}} = \text{Max}[M_{y1}, M_{y2}, M_{y3}] \leq \frac{1}{k_y} \times \frac{C_{0,\text{guide}}}{f_s}$$

$$M_{z,\text{stat}} = \text{Max}[M_{z1}, M_{z2}, M_{z3}] \leq \frac{1}{k_z} \times \frac{C_{0,\text{guide}}}{f_s}$$

$F_{y/z,\text{stat}}$	Maximum value of the calculated force load per cycle phase
$M_{x/y/z,\text{stat}}$	Maximum value of the calculated torque load per cycle phase
$F_{y1/2/3}$	Calculated force load per cycle phase

$M_{x1/2/3}$, $M_{y1/2/3}$, $M_{z1/2/3}$	Calculated torque load per cycle phase
$C_{0,\text{guide}}$	Static basic load rating of ball screw $\rightarrow 27$
$k_{x/y/z}$	Torque equivalence factors $\rightarrow 27$
f_s	Safety factor against static overload $f_s = 1.0 \dots 3.0$

Electric slides EGSP

Technical data

Dimensions

Download CAD Data → www.festo.com/us/cad

EGSP-20/26

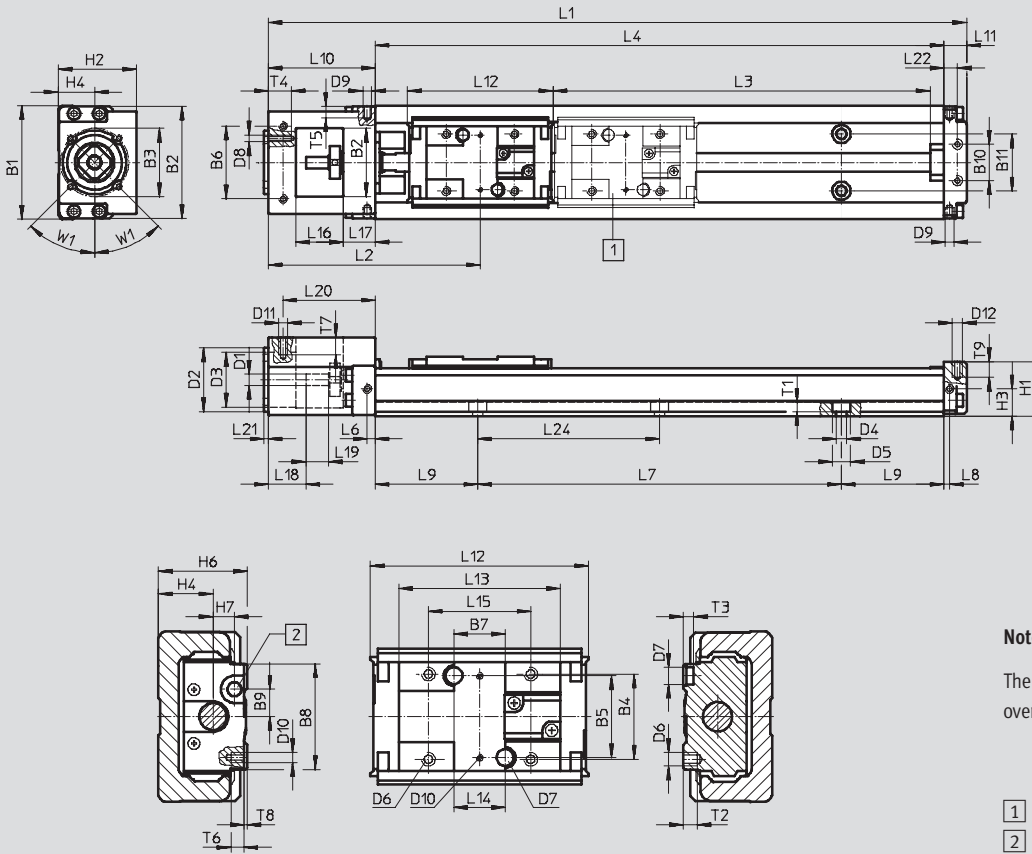

Note
The additional slide has the same overall length as the driven slide.

- 1) Additional slide
- 2) Lubrication hole

Size	Stroke	L1	L3 +4	L4	L7= (n-1)x60	L9	n	Size	Stroke	L1	L3 +4	L4	L7= (n-1)x80	L9	n
20	25	152	39	100	60	20	2	26	50	207	67	150	80	35	2
	75	202	89	150	120	15	3		100	257	117	200	160	20	3
	125	252	139	200	120	40	3		150	307	167	250	160	45	3
									200	357	217	300	240	30	4

Size	B1	B2	B3 Ø	B4	B5 ±0.02	B6 ±0.1	B7	B8	B9	B10 ±0.1	B11	D1 Ø h7	D2 Ø g7	D3 Ø	D4 Ø	D5 Ø	D6	D7 Ø H7	D8
20	40	22	30	18	18	29	10	23	5.5	18	18	4	28	22	3.4	6.5	M3	2	M3
26	50	30	30	25	24	32	15	31	8	16	25	5	28	24	4.5	8	M4	5	M3

Size	D9	D10	D11	D12	H1	H2	H3	H4	H6	H7	L2	L6	L8	L10	L11	L12	L13	L14 ¹⁾ ±0.02
20	M2.6	M1.6	M2.5	M2.5	19	28	10	13	20	4	72.8	3.5	2.5	42	10	46	33.2	10
26	M2.6	M2	M2.5	M3	24	34.5	12	16	26	6.3	91.3	3.5	2.5	47	10	64	47.4	15

Size	L15	L16	L17	L18	L19 ±0.1	L20 ±0.1	L21	L22	L24	T1	T2	T3	T4	T5	T6	T7	T8	T9	W1
20	20	18	12	16	8	34.5	2	6.5	60	3	3	3	10	4	2.4	5	0.9	5	45°
26	30	21	14	16.5	10	40.5	2	6	80	4	4	3	10	4	3	5	0.9	6	45°

1) Distance between the locating holes

Electric slides EGSP

Technical data

Dimensions

Download CAD Data → www.festo.com/us/cad

EGSP-33/46

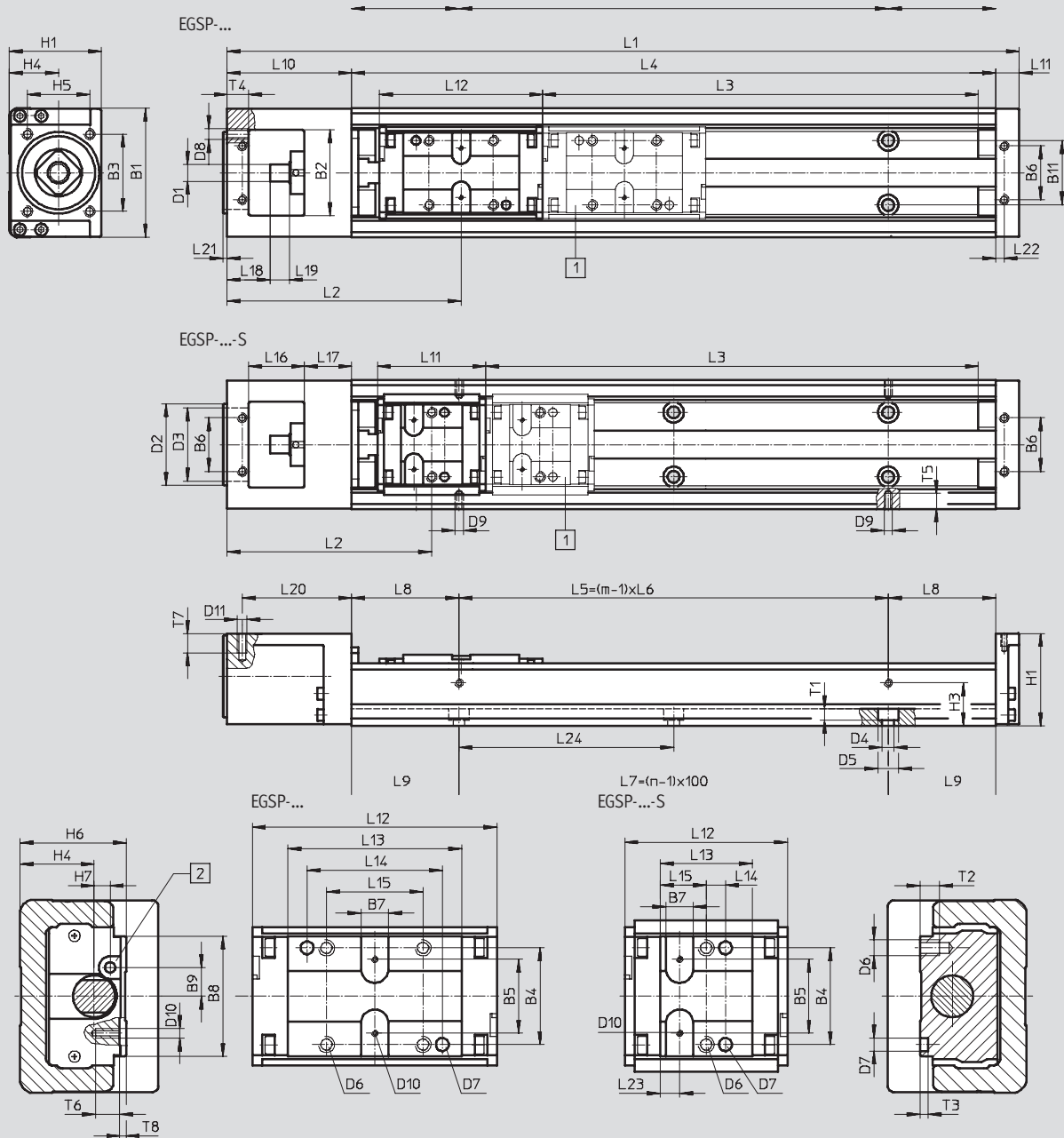

Note

The additional slide has the same overall length as the driven slide.

- 1 Additional slide
- 2 Lubrication hole

Electric slides EGSP

Technical data

FESTO

Size	Stroke	L1	L3 +4		L4	L5	L6	L7	L8	m	n
				S							
33	100	269	103	130	200	100	100	100	50	2	2
	200	369	203	230	300	200	200	200	50	2	3
	300	469	303	330	400	200	200	300	100	2	4
	400	569	403	430	500	400	200	400	50	3	5
	500	669	503	530	600	400	200	500	100	3	6
	600	769	603	630	700	600	200	600	50	4	7

Size	Stroke	L1	L3 +4		L4	L5	L6	L7	L8	m	n
				S							
46	200	425.5	206	240	340	200	200	200	70	2	3
	300	525.5	306	340	440	400	200	300	20	3	4
	400	625.5	406	440	540	400	200	400	70	3	5
	500	725.5	506	540	640	600	200	500	20	4	6
	600	825.5	606	640	740	600	200	600	70	4	7
	800	1,025.5	806	840	940	800	200	800	70	5	9

Size	B1	B2	B3 ±0.1	B4	B5 ±0.04	B6 ±0.1	B7	B8	B9	B10	B11	D1 ∅ h7	D2 ∅ g7	D3 ∅	D4 ∅
33	60	40	36	30	30	25	8.5	37.4	8.9	23	30	8	38	34	5.5
46	86	48	36	46	46	42	10	54.4	10	46	46	10	38	34	6.6

Size	D5 ∅	D6	D7 ∅ H7	D8	D9	D10	D11	H1	H3	H4	H5 ±0.1	H6	H7	L2	
															S
33	9.5	M5	4	M5	M2.6	M2	M3	43	20	23	29	33	5	107	94.3
46	11	M6	5	M5	M2.6	M2	M4	60	29	32	29	46	8	140	123.5

Size	L9	L10	L11	L12		L13		L14		L15		L16	L17	L18	L19
					S		S	±0.04	±0.1		S				
33	50	58	11	76	50.5	54	28.5	42	6	30	14.25	26	22	20	9
46	70	72.5	13	110	77	81	48	28	11	46	24	33.5	25	19.5	18

Size	L20 ±0.1	L21	L22 ±0.1	L24	T1	T2	T3	T4	T5	T6	T7	T8
33	51	2	4	100	5.4	6	2.5	10	3.5	5	6	2
46	65.5	2	6	100	6.5	9	2.5	10	4	5	8	2

Electric slides EGSP

Ordering data – Modular products

Ordering table							
Size	20	26	33	46	Conditions	Code	Enter code
M Module No.	562754	562755	562756	562757			
Drive function	Electric slide drive, with caged balls					EGSP	EGSP
Size	20	26	33	46		-...	-...
Standard stroke for standard slide [mm]	25	-	-	-		-25	-...
	-	50	-	-		-50	-...
	75	-	-	-		-75	-...
	-	100	-	-		-100	-...
	125	-	-	-		-125	-...
	-	150	-	-		-150	-...
	-	200	-	-		-200	-...
	-	-	300	-		-300	-...
	-	-	400	-		-400	-...
	-	-	500	-		-500	-...
	-	-	600	-		-600	-...
	-	-	-	800		-800	-...
	Standard stroke for slide, short [mm]	-	-	130	-		-130
-		-	230	-		-230	-...
-		-	-	240		-240	-...
-		-	330	-		-330	-...
-		-	-	340		-340	-...
-		-	430	-		-430	-...
-		-	-	440		-440	-...
-		-	530	-		-530	-...
-		-	-	540		-540	-...
-		-	630	-		-630	-...
-		-	-	640		-640	-...
Spindle pitch [mm]	1	-	-	-		-1P	-...
	-	2	-	-		-2P	-...
	6	-	-	-		-6P	-...
	-	-	10	-		-10P	-...
	20	-	20	-		-20P	-...
O Accuracy	Standard accuracy						
	Greater accuracy					-H	
	Precision accuracy				[1]	-P	
Slide design	Standard slide					-	
			Slide, short		[2]	-S	
Additional slide	No additional slide					-	
	Additional slide (additional slide Z in combination with slide design S also results in a short slide)				[3]	-Z	

- [1] **P** With size 46 not in combination with stroke for standard slide 800 and stroke for slide, short 840
- [2] **S** With size 33 not in combination with spindle pitch 20
- [3] **Z** With size 20 not in combination with stroke for standard slide 25
With size 26 not in combination with stroke for standard slide 50
With size 33 not in combination with stroke for standard slide 100

Transfer order code

EGSP - - - - - - -

Electric slides EGSK/EGSP

Accessories

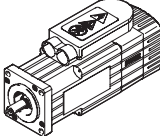
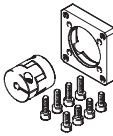
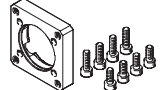
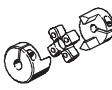
Permissible axis/motor combinations with axial kit – without gear unit			
Motor	Axial kit	Axial kit comprising:	
		Motor flange	Coupling
			
Type	Part No. Type	Part No. Type	Part No. Type
EGSK-20/EGSP-20			
With servo motor			
EMMS-AS-40-M-...	562637 EAMM-A-P4-28B-40A	552163 EAMF-A-28B-40A	562673 EAMC-16-20-4-6
With stepper motor			
EMMS-ST-42-S-...	562636 EAMM-A-P4-28B-42A	552164 EAMF-A-28B-42A	562674 EAMC-16-20-4-5
EGSK-26/EGSP-26			
With servo motor			
EMMS-AS-40-M-...	562641 EAMM-A-P5-28B-40A	552163 EAMF-A-28B-40A	543419 EAMC-16-20-5-6
With stepper motor			
EMMS-ST-42-S-...	562640 EAMM-A-P5-28B-42A	552164 EAMF-A-28B-42A	562676 EAMC-16-20-5-5
EGSK-33			
With servo motor			
EMMS-AS-40-M-...	562646 EAMM-A-P6-38A-40A	562667 EAMF-A-38A-40A	558312 EAMC-30-32-6-6
EMMS-AS-55-S-...	562647 EAMM-A-P6-38A-55A	558176 EAMF-A-38A-55A	551003 EAMC-30-32-6-9
With stepper motor			
EMMS-ST-42-S-...	562644 EAMM-A-P6-38A-42A	562668 EAMF-A-38A-42A	561333 EAMC-30-32-5-6
EMMS-ST-57-S-...	562645 EAMM-A-P6-38A-57A	560692 EAMF-A-38A-57A	551002 EAMC-30-32-6-6.35
EGSK-46/EGSP-33			
With servo motor			
EMMS-AS-40-M-...	562652 EAMM-A-P8-38A-40A	562667 EAMF-A-38A-40A	533708 EAMC-30-32-6-8
EMMS-AS-55-S-...	562653 EAMM-A-P8-38A-55A	558176 EAMF-A-38A-55A	543423 EAMC-30-32-8-9
EMMS-AS-70-S-...	564996 EAMM-A-P8-38A-70A	558018 EAMF-A-38A-70A	551004 EAMC-30-32-8-11
With stepper motor			
EMMS-ST-42-S-...	562650 EAMM-A-P8-38A-42A	562668 EAMF-A-38A-42A	562678 EAMC-30-32-5-8
EMMS-ST-57-S-...	562651 EAMM-A-P8-38A-57A	560692 EAMF-A-38A-57A	543421 EAMC-30-32-6.35-8
EMMS-ST-87-S-...	564998 EAMM-A-P8-38A-87A	560693 EAMF-A-38A-87A	551004 EAMC-30-32-8-11

Electric slides EGSK/EGSP

Accessories

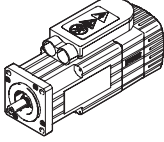
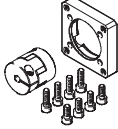
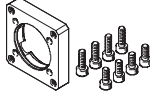
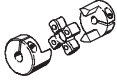
Permissible axis/motor combinations with axial kit – without gear unit			
Motor	Axial kit	Axial kit comprising:	
		Motor flange	Coupling
			
Type	Part No. Type	Part No. Type	Part No. Type
EGSP-46			
With servo motor			
EMMS-AS-55-S-...	562659 EAMM-A-P10-38A-55A	558176 EAMF-A-38A-55A	562680 EAMC-30-32-9-10
EMMS-AS-70-S-...	564997 EAMM-A-P10-38A-70A	558018 EAMF-A-38A-70A	565008 EAMC-30-32-10-11
With stepper motor			
EMMS-ST-57-S-...	562658 EAMM-A-P10-38A-57A	560692 EAMF-A-38A-57A	562679 EAMC-30-32-6.35-10
EMMS-ST-87-S-...	564999 EAMM-A-P10-38A-87A	560693 EAMF-A-38A-87A	565008 EAMC-30-32-10-11

Electric slides EGSK/EGSP

Accessories



Axial kit EAMM-A-...

Material:
Coupling hubs, motor flange:
Aluminium
Screws: Steel
RoHS-compliant

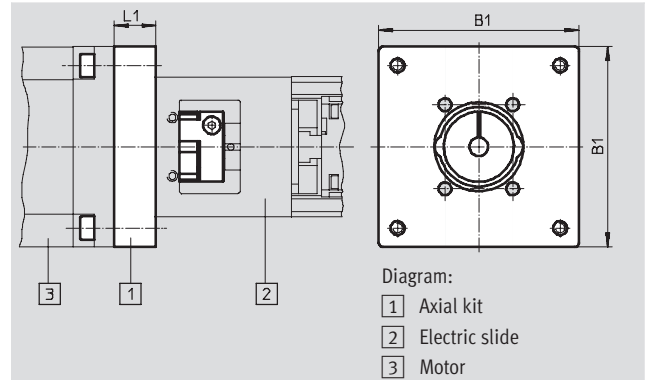

General technical data									
EAMM-A-...	P4-28B-		P5-28B-		P6-38A-				
	40A	42A	40A	42A	40A	42A	55A	57A	
Transferable torque [Nm]	0.7	0.7	1.1	1.1	6.5	3.5	6.5	6.5	
Mass moment of inertia [kgmm ²]	0.28				5.88				
Max. rotational speed [1/min]	10,000				8,000				
Installation position	Any								

EAMM-A-...	P8-38A-						P10-38A-				
	40A	42A	55A	57A	70A	87A	55A	57A	70A	87A	
Transferable torque [Nm]	6.5	3.5	12.5	6.5	12.5	12.5	12.5	6.5	12.5	12.5	
Mass moment of inertia [kgmm ²]	5.88										
Max. rotational speed [1/min]	8,000										
Installation position	Any										

Operating and environmental conditions		
Ambient temperature [°C]	0 ... +50	
Storage temperature [°C]	-25 ... +60	
Relative air humidity [%]	0 ... 95 (non-condensing)	

Dimensions and ordering data						
Type	B1	L1	Weight [g]	Part No.	Type	
EAMM-A-P4-28B-40A	40	8.3	50	562637	EAMM-A-P4-28B-40A	
EAMM-A-P5-28B-40A				562641	EAMM-A-P5-28B-40A	
EAMM-A-P4-28B-42A	42	16.5	60	562636	EAMM-A-P4-28B-42A	
EAMM-A-P5-28B-42A				562640	EAMM-A-P5-28B-42A	
EAMM-A-P6-38A-40A	50	9	100	562646	EAMM-A-P6-38A-40A	
EAMM-A-P8-38A-40A				562652	EAMM-A-P8-38A-40A	
EAMM-A-P6-38A-42A	55	15	160	562644	EAMM-A-P6-38A-42A	
EAMM-A-P8-38A-42A				562650	EAMM-A-P8-38A-42A	
EAMM-A-P6-38A-55A	55	11	130	562647	EAMM-A-P6-38A-55A	
EAMM-A-P8-38A-55A				562653	EAMM-A-P8-38A-55A	
EAMM-A-P10-38A-55A				562659	EAMM-A-P10-38A-55A	
EAMM-A-P6-38A-57A	56	11	130	562645	EAMM-A-P6-38A-57A	
EAMM-A-P8-38A-57A				562651	EAMM-A-P8-38A-57A	
EAMM-A-P10-38A-57A				562658	EAMM-A-P10-38A-57A	
EAMM-A-P8-38A-70A	70	13.75	200	564996	EAMM-A-P8-38A-70A	
EAMM-A-P10-38A-70A				564997	EAMM-A-P10-38A-70A	
EAMM-A-P8-38A-87A	85.8	18	380	564998	EAMM-A-P8-38A-87A	
EAMM-A-P10-38A-87A				564999	EAMM-A-P10-38A-87A	

Electric slides EGSK/EGSP

Accessories

Cross connecting kit EHAM

Material:

Adapter plate: Anodised aluminium

Screws, locating pins: Steel

RoHS-compliant

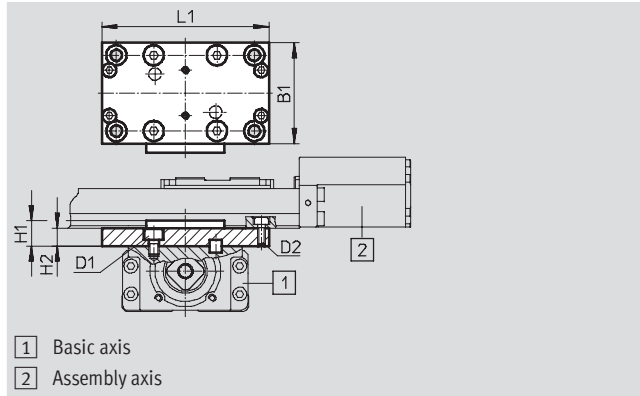

Dimensions and ordering data										
For size		B1	D1	D2	H1	H2	L1	Weight [g]	Part No.	Type
Basic axis 1	Assembly axis 2	±0.2					±0.2			
20	15	30	M3	M3	7	5	56	27	563747	EHAM-S1-20-15
26	20	40	M4	M3	10	7	66	59	563748	EHAM-S1-26-20
33	26	54	M5	M4	12	9	86	124	563749	EHAM-S1-33-26
46	33	60	M6	M5	15	10	112	216	563750	EHAM-S1-46-33

Electric slides EGSK/EGSP

Accessories



Slide adapter EASA

Material:
 Adapter plate: Anodised aluminium
 Screws, locating pins: Steel
 RoHS-compliant

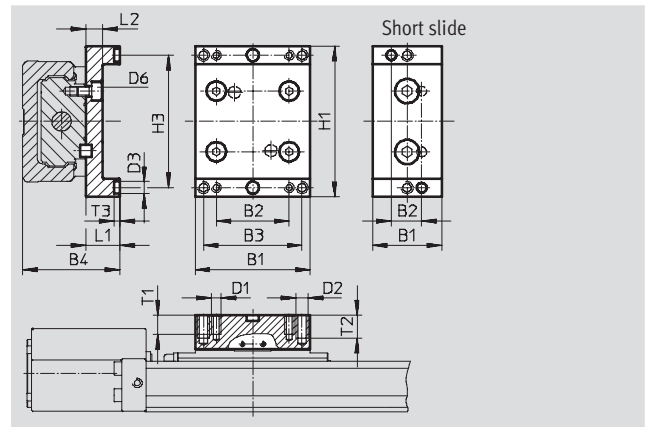
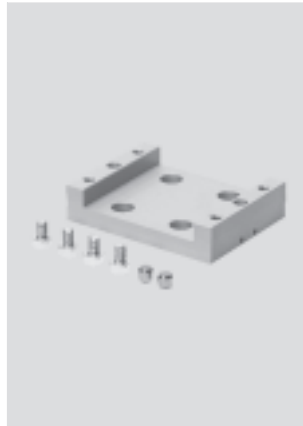

Dimensions and ordering data										
For size	B1	B2	B3	B4	D1	D2	D3	D6	H1	H3
	±0.2						∅ H7		±0.2	±0.04
With standard slide										
15	23	14	–	25	M3	–	4	M3	44	38
20	33.2	23	–	32	M3	–	2	M3	52	44.5
26	47.4	30	–	40	M4	–	5	M4	62	54.5
33	54	40	–	48	M5	–	4	M5	86	74
46	81	30	48	68	M5	M6	5	M6	112	100
With short slide										
33	28.5	12.5±0.04	–	48	M5	–	4	M5	86	74
46	48	22±0.04	–	68	M6	–	5	M6	112	100

For size	L1	L2	T1	T2	T3	Weight [g]	Part No.	Type
					±0.1			
With standard slide								
15	10	5.4	6	–	2.5	20	562742	EASA-S1-15
20	12	6	6	–	2.5	38	562743	EASA-S1-20
26	14	7	8	–	2.5	74	562744	EASA-S1-26
33	15	9	15	–	2.6	130	562745	EASA-S1-33
46	22	10	10	12	2.6	310	562746	EASA-S1-46
With short slide								
33	15	9	15	–	2.6	70	562747	EASA-S1-33-S
46	22	10	12	–	2.6	180	562748	EASA-S1-46-S

Electric slides EGSK/EGSP

Accessories

Covering kit EASC
for standard slide

Material:
Cover profile, adapter plate, adapter:
Anodised aluminium
Screws, locating pins: Steel
RoHS-compliant

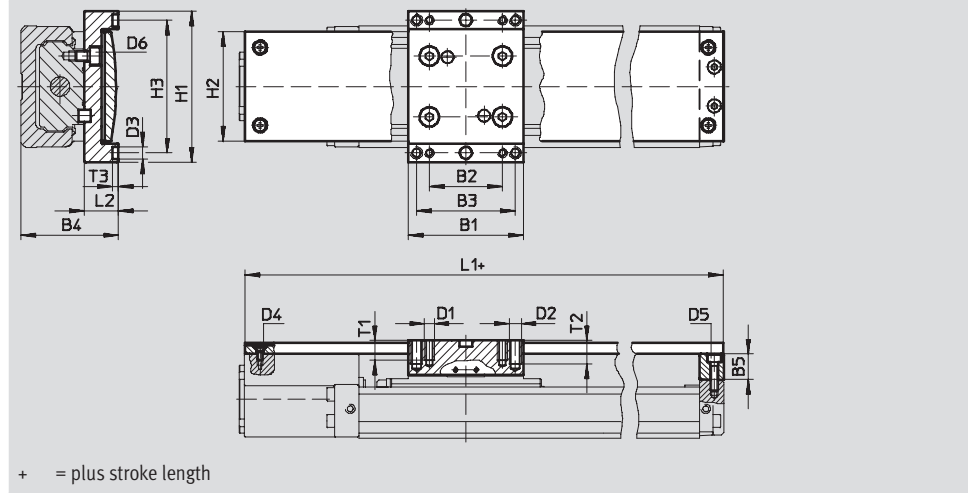

Dimensions										
For size	B1	B2	B3	B4	B5	D1	D2	D3 ∅ H7	D4	D5
	±0.2									
15	23	14	–	25	6.5	M3	–	4	M2	M2
20	33.2	23		32	9	M3		2	M2.5	M2.5
26	47.4	30		40	10.5	M4		5	M2.5	M3
33	54	40		48	7	M5		4	M3	M3
46	81	30	48	68	10	M5	M6	5	M4	M4

For size	D6	H1	H2	H3	L1	L2	T1	T2	T3
		±0.2	±0.2	±0.04	–0.3				+0.1
15	M3	44	30	38	96.7	10	6	–	2.5
20	M3	52	35.6	44.5	126.2	12	6		2.5
26	M4	62	45	54.5	156.2	14	8		2.5
33	M5	86	62.5	74	168.2	15	15		2.6
46	M6	112	82.4	100	224.7	22	10	12	2.6

Ordering data										
For size	Stroke [mm]	Weight [g]	Part No.	Type	For size	Stroke [mm]	Weight [g]	Part No.	Type	
15	25	51	562707	EASC-S1-15-25	33	100	327	562718	EASC-S1-33-100	
	50	57	562708	EASC-S1-15-50		200	391	562719	EASC-S1-33-200	
	75	62	562709	EASC-S1-15-75		300	454	562720	EASC-S1-33-300	
	100	67	562710	EASC-S1-15-100		400	518	562721	EASC-S1-33-400	
20	25	92	562711	EASC-S1-20-25		500	581	562722	EASC-S1-33-500	
	75	107	562712	EASC-S1-20-75		600	645	562723	EASC-S1-33-600	
	125	121	562713	EASC-S1-20-125		46	200	850	562724	EASC-S1-46-200
26	50	187	562714	EASC-S1-26-50			300	965	562725	EASC-S1-46-300
	100	211	562715	EASC-S1-26-100			400	1,080	562726	EASC-S1-46-400
	150	234	562716	EASC-S1-26-150			500	1,200	562727	EASC-S1-46-500
	200	258	562717	EASC-S1-26-200	600		1,310	562728	EASC-S1-46-600	
					800		1,540	562729	EASC-S1-46-800	

Electric slides EGSK/EGSP

Accessories

Covering kit EASC
for slide, short

Material:
Cover profile, adapter plate, adapter:
Anodised aluminium
Screws, locating pins: Steel
RoHS-compliant

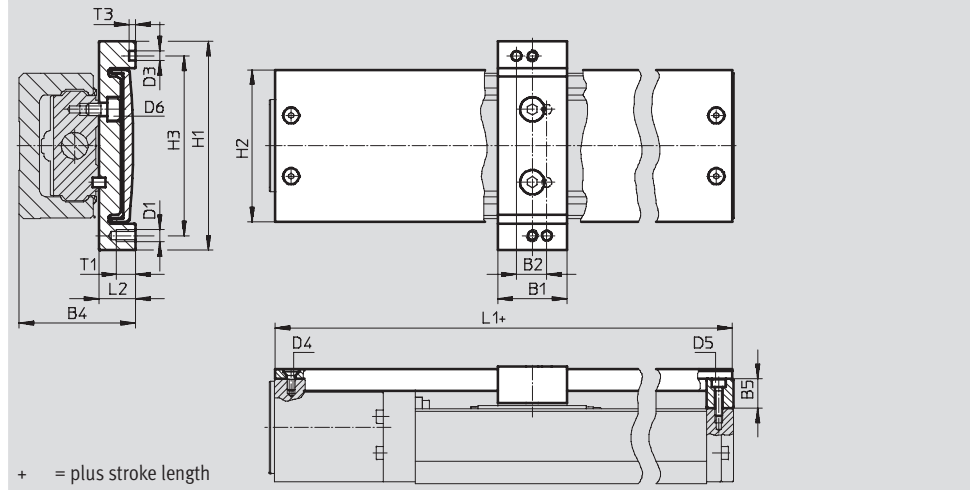

Dimensions								
For size	B1	B2	B4	B5	D1	D3 ∅	D4	D5
	±0.2	±0.04				H7		
33	28.5	12.5	48	7	M5	4	M3	M3
46	48	22	68	10	M6	5	M4	M4

For size	D6	H1	H2	H3	L1	L2	T1	T3
		±0.2	±0.2	±0.04	-0.3			+0.1
33	M5	86	62.5	74	138.2	15	15	2.6
46	M6	112	82.4	100	184.7	22	12	2.6

Ordering data				
For size	Stroke [mm]	Weight [g]	Part No.	Type
33	130	263	562730	EASC-S1-33-130-S
	230	328	562731	EASC-S1-33-230-S
	330	391	562732	EASC-S1-33-330-S
	430	454	562733	EASC-S1-33-430-S
	530	518	562734	EASC-S1-33-530-S
	630	581	562735	EASC-S1-33-630-S
46	240	724	562736	EASC-S1-46-240-S
	340	840	562737	EASC-S1-46-340-S
	440	955	562738	EASC-S1-46-440-S
	540	1,070	562739	EASC-S1-46-540-S
	640	1,190	562740	EASC-S1-46-640-S
	840	1,420	562741	EASC-S1-46-840-S

Electric slides EGSK/EGSP

Accessories

Sensor strip EAPR

Material:
 Sensor bracket: Anodised aluminium
 Switching lug, screws:
 Galvanised steel
 RoHS-compliant

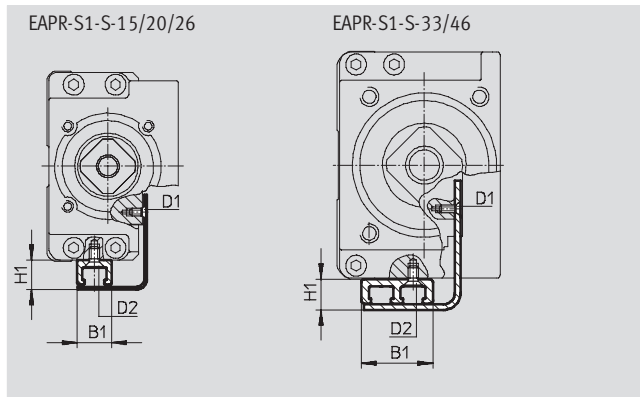

Dimensions						
For size	B1	H1		D1		D2
For type		EGSK	EGSP	EGSK	EGSP	
With standard slide						
15	9	8.5	-	M2	-	M2
20		7.75	7.75		M3	M1.6
26				M2	M2	
33	19	7.75	8.5	M2	M2	M2.5
46						
With slide, short						
33	19	7.5	8.5	M2	M2	M2.5
46		8.5				

Ordering data					
For size	Stroke	Weight	Part No.	Type	
For type	[mm]	[g]			
With standard slide					
15	25	10	562611	EAPR-S1-S-15-25	
	50	12	562612	EAPR-S1-S-15-50	
	75	14	562613	EAPR-S1-S-15-75	
	100	16	562614	EAPR-S1-S-15-100	
20	25	14	562615	EAPR-S1-S-20-25	
	75	18	562616	EAPR-S1-S-20-75	
	125	22	562617	EAPR-S1-S-20-125	
26	50	24	562618	EAPR-S1-S-26-50	
	100	28	562619	EAPR-S1-S-26-100	
	150	32	562620	EAPR-S1-S-26-150	
	200	37	562621	EAPR-S1-S-26-200	
With standard slide or slide, short					
33	100/130-S	51	562622	EAPR-S1-S-33-100/130-S	
	200/230-S	69	562623	EAPR-S1-S-33-200/230-S	
	300/330-S	88	562624	EAPR-S1-S-33-300/330-S	
	400/430-S	106	562625	EAPR-S1-S-33-400/430-S	
	500/530-S	125	562626	EAPR-S1-S-33-500/530-S	
	600/630-S	144	562627	EAPR-S1-S-33-600/630-S	
46	200/240-S	78	562628	EAPR-S1-S-46-200/240-S	
	300/340-S	97	562629	EAPR-S1-S-46-300/340-S	
	400/440-S	115	562630	EAPR-S1-S-46-400/440-S	
	500/540-S	134	562631	EAPR-S1-S-46-500/540-S	
	600/640-S	153	562632	EAPR-S1-S-46-600/640-S	
	800/840-S	190	562633	EAPR-S1-S-46-800/840-S	

Electric slides EGSK/EGSP



Accessories

FESTO

Ordering data – Centring pins, centring sleeves					
	For size	Comment	Part No.	Type	PU ¹⁾
	15	For slide	189652	ZBH-5	10
	20		525273	ZBS-2	
	26, 46		150928	ZBS-5	
	33		562959	ZBS-4	
	15, 33	For slide adapter	562959	ZBS-4	
	20		525273	ZBS-2	
	26, 46		150928	ZBS-5	

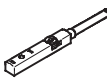
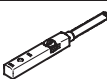
1) Packaging unit quantity

Ordering data – Proximity sensors for T-slot, inductive					Technical data → Internet: sies	
	Type of mounting	Switching output	Electrical connection	Cable length [m]	Part No.	Type
N/O contact						
	Insertable in slot from above, flush with sensor strip	PNP	Cable, 3-wire	7.5	551386	SIES-8M-PS-24V-K-7,5-OE
			Plug M8x1, 3-pin	0.3	551387	SIES-8M-PS-24V-K-0,3-M8D
		NPN	Cable, 3-wire	7.5	551396	SIES-8M-NS-24V-K-7,5-OE
			Plug M8x1, 3-pin	0.3	551397	SIES-8M-NS-24V-K-0,3-M8D
N/C contact						
	Insertable in slot from above, flush with sensor strip	PNP	Cable, 3-wire	7.5	551391	SIES-8M-PO-24V-K-7,5-OE
			Plug M8x1, 3-pin	0.3	551392	SIES-8M-PO-24V-K-0,3-M8D
		NPN	Cable, 3-wire	7.5	551401	SIES-8M-NO-24V-K-7,5-OE
			Plug M8x1, 3-pin	0.3	551402	SIES-8M-NO-24V-K-0,3-M8D

Ordering data – Connecting cables				Technical data → Internet: nebu	
	Electrical connection, left	Electrical connection, right	Cable length [m]	Part No.	Type
	Straight socket, M8x1, 3-pin	Cable, open end, 3-wire	2.5	541333	NEBU-M8G3-K-2.5-LE3
			5	541334	NEBU-M8G3-K-5-LE3
	Angled socket, M8x1, 3-pin	Cable, open end, 3-wire	2.5	541338	NEBU-M8W3-K-2.5-LE3
			5	541341	NEBU-M8W3-K-5-LE3

Product Range and Company Overview

A Complete Suite of Automation Services

Our experienced engineers provide complete support at every stage of your development process, including: conceptualization, analysis, engineering, design, assembly, documentation, validation, and production.



Custom Automation Components
Complete custom engineered solutions



Custom Control Cabinets
Comprehensive engineering support and on-site services



Complete Systems
Shipment, stocking and storage services

The Broadest Range of Automation Components

With a comprehensive line of more than 30,000 automation components, Festo is capable of solving the most complex automation requirements.



Electromechanical
Electromechanical actuators, motors, controllers & drives



Pneumatics
Pneumatic linear and rotary actuators, valves, and air supply



PLCs and I/O Devices
PLC's, operator interfaces, sensors and I/O devices

Supporting Advanced Automation... As No One Else Can!

Festo is a leading global manufacturer of pneumatic and electromechanical systems, components and controls for industrial automation, with more than 12,000 employees in 56 national headquarters serving more than 180 countries. For more than 80 years, Festo has continuously elevated the state of manufacturing with innovations and optimized motion control solutions that deliver higher performing, more profitable automated manufacturing and processing equipment. Our dedication to the advancement of automation extends beyond technology to the education and development of current and future automation and robotics designers with simulation tools, teaching programs, and on-site services.

Quality Assurance, ISO 9001 and ISO 14001 Certifications

Festo Corporation is committed to supply all Festo products and services that will meet or exceed our customers' requirements in product quality, delivery, customer service and satisfaction.

To meet this commitment, we strive to ensure a consistent, integrated, and systematic approach to management that will meet or exceed the requirements of the ISO 9001 standard for Quality Management and the ISO 14001 standard for Environmental Management.



© Copyright 2008, Festo Corporation. While every effort is made to ensure that all dimensions and specifications are correct, Festo cannot guarantee that publications are completely free of any error, in particular typing or printing errors. Accordingly, Festo cannot be held responsible for the same. For Liability and Warranty conditions, refer to our "Terms and Conditions of Sale", available from your local Festo office. All rights reserved. No part of this publication may be reproduced, distributed, or transmitted in any form or by any means, electronic, mechanical, photocopying or otherwise, without the prior written permission of Festo. All technical data subject to change according to technical update.



Printed on recycled paper at New Horizon Graphic, Inc., FSC certified as an environmentally friendly printing plant.

Festo North America

Festo Regional Contact Center

5300 Explorer Drive
Mississauga, Ontario L4W 5G4
Canada

USA Customers:

For ordering assistance,

Call: 1.800.99.FESTO (1.800.993.3786)

Fax: 1.800.96.FESTO (1.800.963.3786)

Email: customer.service@us.festo.com

For technical support,

Call: 1.866.GO.FESTO (1.866.463.3786)

Fax: 1.800.96.FESTO (1.800.963.3786)

Email: product.support@us.festo.com

Canadian Customers:

Call: 1.877.GO.FESTO (1.877.463.3786)

Fax: 1.877.FX.FESTO (1.877.393.3786)

Email: festo.canada@ca.festo.com

USA Headquarters

Festo Corporation
395 Moreland Road
P.O. Box 18023
Hauppauge, NY 11788, USA
www.festo.com/us

USA Sales Offices

Appleton

North 922 Tower View Drive, Suite N
Greenville, WI 54942, USA

Boston

120 Presidential Way, Suite 330
Woburn, MA 01801, USA

Chicago

1441 East Business Center Drive
Mt. Prospect, IL 60056, USA

Dallas

1825 Lakeway Drive, Suite 600
Lewisville, TX 75057, USA

Detroit – Automotive Engineering Center

2601 Cambridge Court, Suite 320
Auburn Hills, MI 48326, USA

New York

395 Moreland Road
Hauppauge, NY 11788, USA

Silicon Valley

4935 Southfront Road, Suite F
Livermore, CA 94550, USA

United States



USA Headquarters, East: Festo Corp., 395 Moreland Road, Hauppauge, NY 11788

Phone: 1.631.435.0800; Fax: 1.631.435.8026;

Email: info@festo-usa.com

www.festo.com/us

Canada



Headquarters: Festo Inc., 5300 Explorer Drive, Mississauga, Ontario L4W 5G4

Phone: 1.905.624.9000; Fax: 1.905.624.9001;

Email: festo.canada@ca.festo.com

www.festo.ca

Mexico



Headquarters: Festo Pneumatic, S.A., Av. Ceylán 3, Col. Tequesquahuac,
54020 Tlalneantla, Edo. de México

Phone: 011 52 [55] 53 21 66 00; Fax: 011 52 [55] 53 21 66 65;

Email: festo.mexico@mx.festo.com

www.festo.com/mx

Central USA

Festo Corporation
1441 East Business
Center Drive
Mt. Prospect, IL 60056, USA
Phone: 1.847.759.2600
Fax: 1.847.768.9480



Western USA

Festo Corporation
4935 Southfront Road,
Suite F
Livermore, CA 94550, USA
Phone: 1.925.371.1099
Fax: 1.925.245.1286



Festo Worldwide

Argentina Australia Austria Belarus Belgium Brazil Bulgaria Canada Chile China Colombia Croatia Czech Republic Denmark
Estonia Finland France Germany Great Britain Greece Hong Kong Hungary India Indonesia Iran Ireland Israel Italy Japan Latvia
Lithuania Malaysia Mexico Netherlands New Zealand Norway Peru Philippines Poland Romania Russia Serbia Singapore
Slovakia Slovenia South Africa South Korea Spain Sweden Switzerland Taiwan Thailand Turkey Ukraine United States Venezuela

www.festo.com