

Valve terminals type 84 VTOC

FESTO



Valve terminals type 84 VTOC

Key features

FESTO

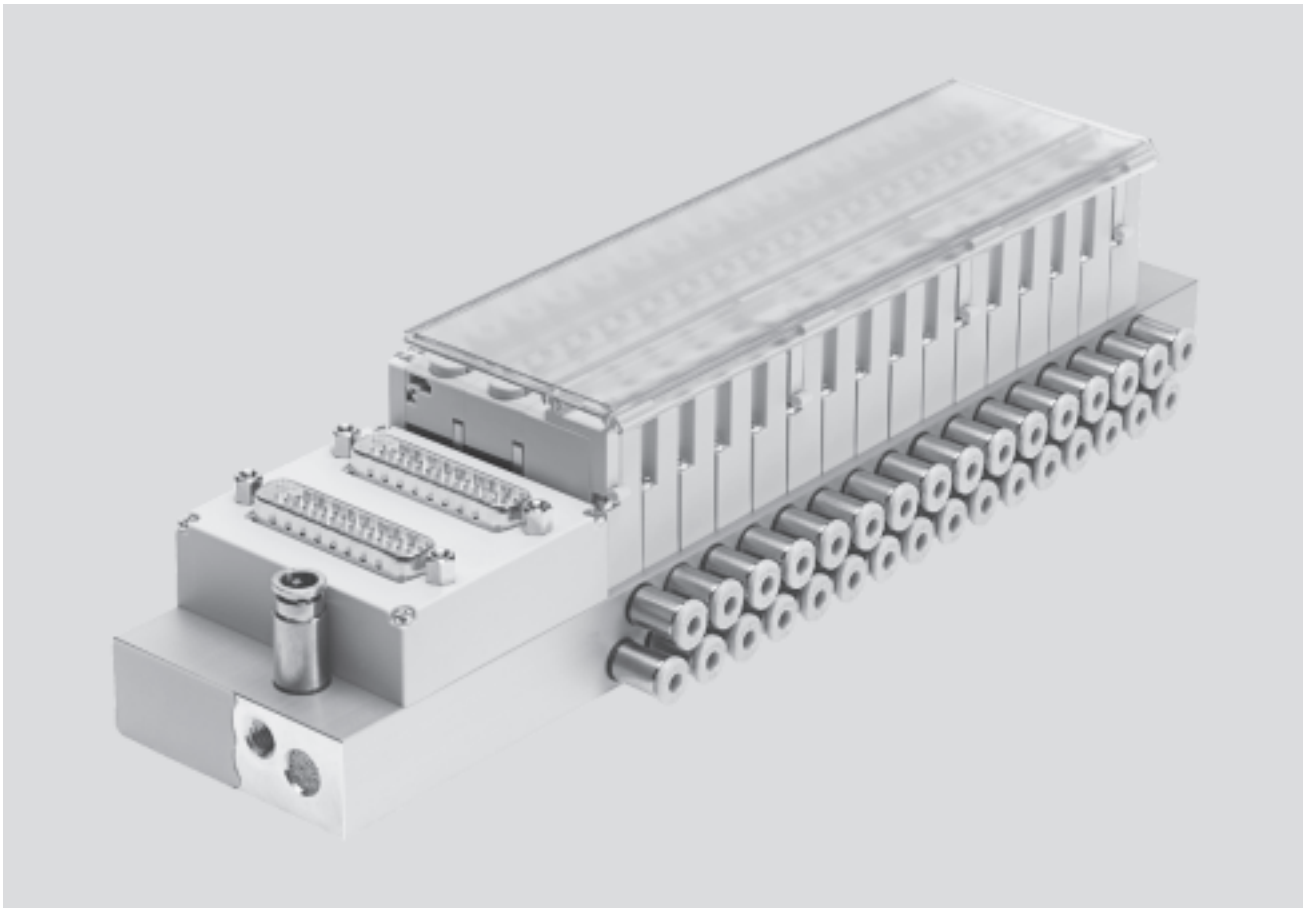

Innovative

- Valve terminal for a wide range of pneumatic applications
- Weight-optimised metal manifold rail
- Space-saving thanks to 2x3/2-way valves on one valve position
- Great flexibility during planning, assembly and operation
- Configurable manifold rails (pneumatic and electric connections)

Versatile

- Provides 2 ... 24 valve positions on one terminal
- Flexibility of the pneumatic working lines provides a practical solution to different requirements
- Wide range of electrical outlet directions
- Multi-pin plug connection with Sub-D plug or flat cable

Reliable

- Manual override
- Durable
- Sturdy thanks to simple structure

Easy to mount

- Ready-to-install and tested unit
- Lower ordering, installation and commissioning costs
- Easy valve assembly

-  - Note

Ordering system for valve terminal type 84 VTOC

➔ Internet: vtoc

Valve terminals type 84 VTOC

Key features

FESTO

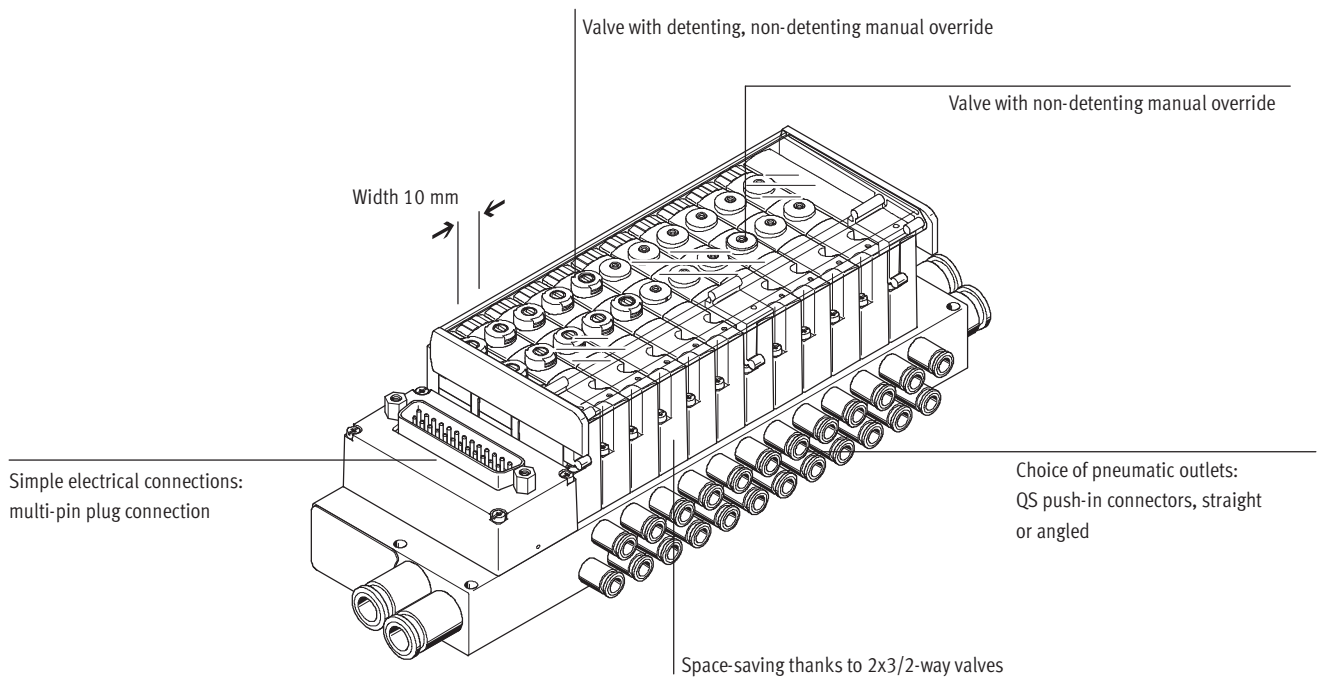

Equipment options

Valve functions

- 2x3/2-way valve, single solenoid, normally closed
- Valve with detenting, non-detenting manual override
- Valve with non-detenting manual override

Electrical connection options

- Multi-pin plug
- 2 ... 24 valve positions/
max. 48 solenoid coils
- Sub-D/flat cable

Valve terminals type 84 VTOC

Peripherals overview

Overview of valve terminals type 84 VTOC

Valve terminal with electrical multi-pin plug connection

- Up to 24 valve positions/
48 solenoid coils
- Flat cable connection type, code: RC
- Sub-D plug connection type, code:
SD

Valve terminals with electrical multi-pin plug connection are available in gradations from 2 to max. 24 valve positions. Each valve position can either be equipped with a valve body or a blanking plate.

Only valve bodies containing two single solenoid 3/2-way valves are available.

A maximum of 48 valve solenoid coils can be actuated via the electrical multi-pin plug connection.

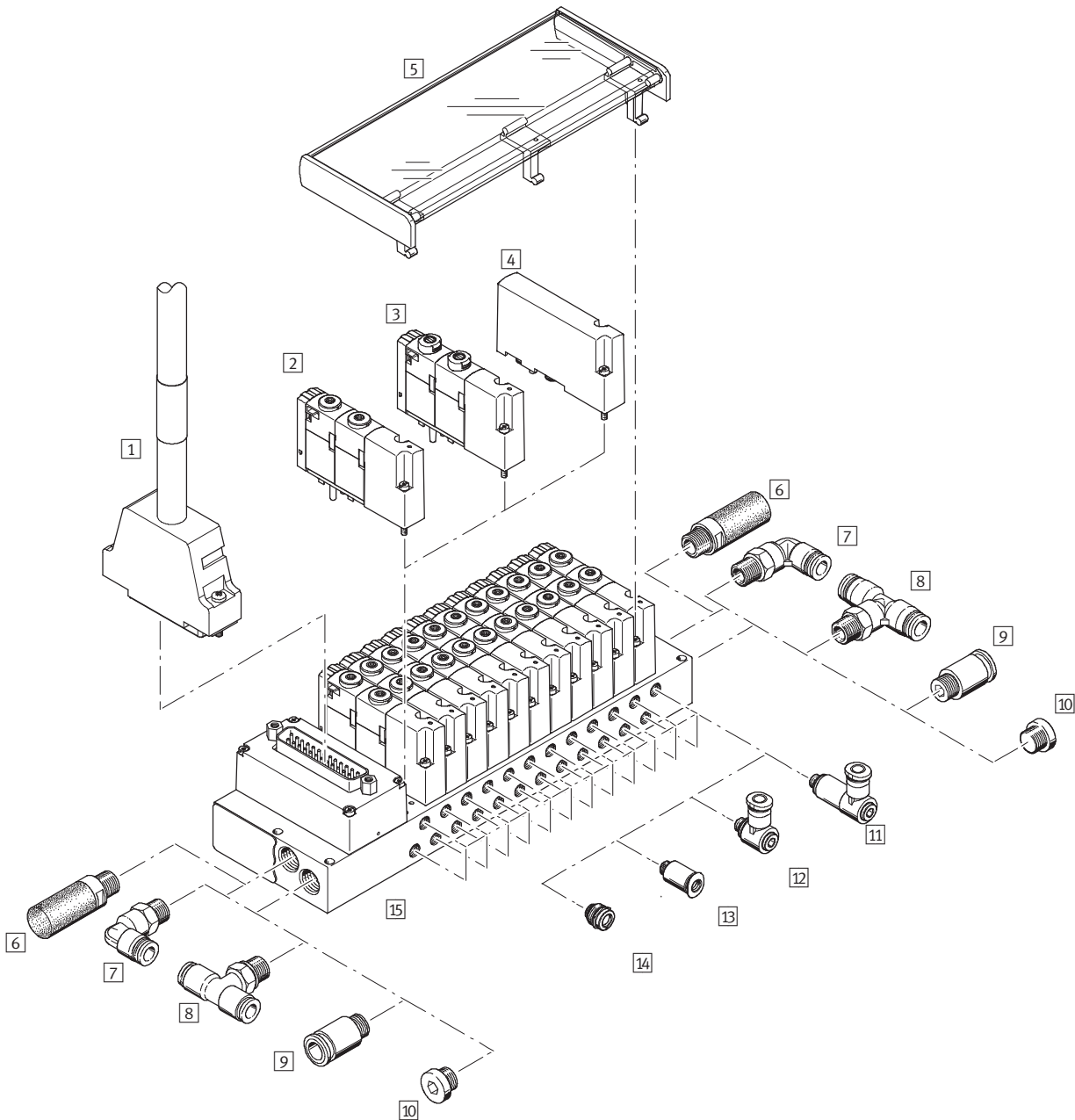

Valve terminals type 84 VTOC

Peripherals overview

FESTO

Accessories				
	Type	Brief description	→ Page/ Internet	
1	Connecting cable	KMP6	Connecting cable for multi-pin plug connection, with Sub-D plug, 25-pin	24
2	Single solenoid valve	VOVC	Solenoid valve with non-detenting manual override	24
3	Single solenoid valve	VOVC	Solenoid valve with detenting, non-detenting manual override	24
4	Blanking plate	VABB	Blanking plate for vacant position	24
5	Inscription label holder	ASCF	For labelling the valves/manual override cover	24
6	Silencer	U	For fitting in exhaust ports	25
7	Push-in L-fitting	QSL	For connecting to the air supply or exhaust	25
8	T-fitting	QST	For connecting to the air supply or exhaust	25
9	Straight fitting	OS	For connecting to the air supply or exhaust	25
10	Blanking plug	B	For sealing the port for the air supply or exhaust	24
11	Push-in L-fitting, long	QSMLLV	Long elbow connector for working lines	25
12	Push-in L-fitting	QSMLV	Elbow connector for working lines	25
13	Push-in fitting	QS	Straight push-in fitting for working lines	25
14	Push-in fitting	QSIMG	Straight countersunk push-in fitting for working lines (compact)	–
15	Manifold rail	VABB	With multi-pin plug connection for max. 24 valve positions	–

Valve terminals type 84 VTOC

Peripherals overview

Overview of electrical connections

Valve terminal with flat cable connection on top

- Flat cable connection type, code: RC
- Connection direction:
 - Left (code LT)
 - Right (code RT)

VTOC valve terminals with electrical multi-pin plug connection are available in gradations from 2 to max. 24 valve positions. A valve body occupies one valve position and contains two single solenoid 3/2-way valves.

A maximum of 48 solenoid coils can therefore be actuated via the electrical multi-pin plug connection.

A total of 19 pin allocation variants are available.

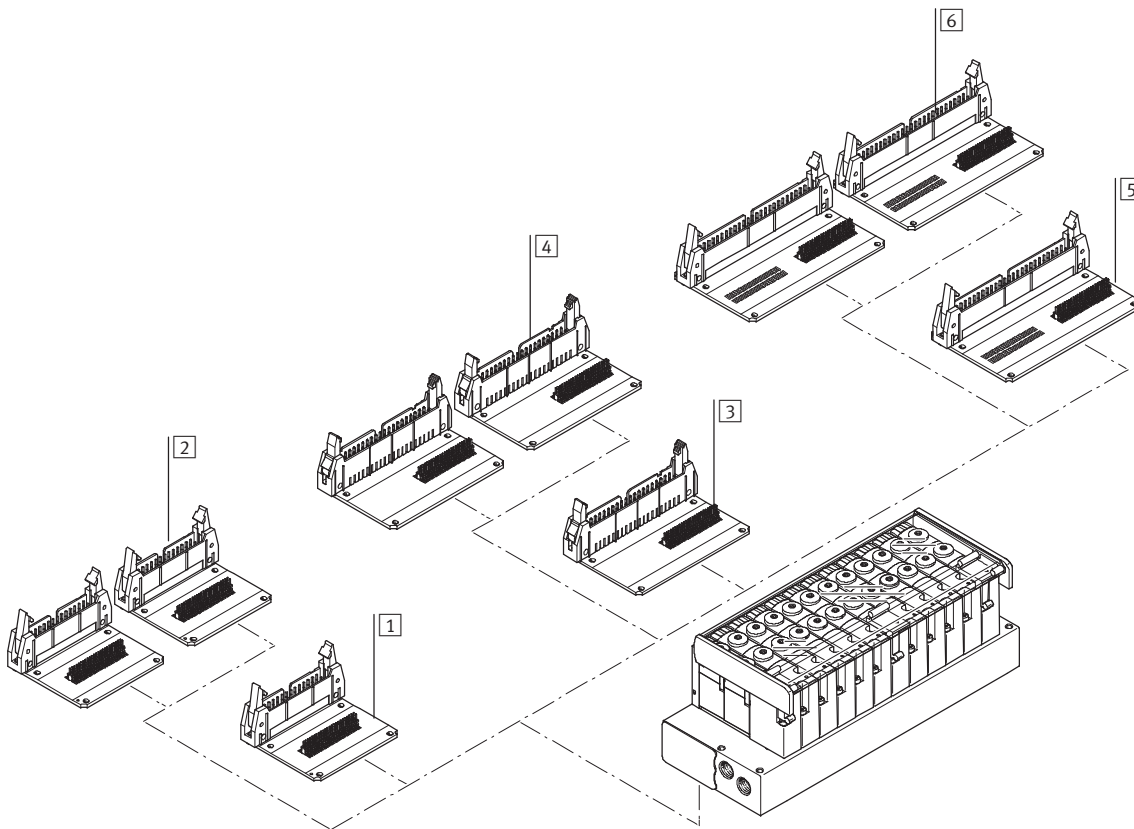

Accessories		
	Code	Brief description
1	LT	1-way, top left
2		2-way, top left
3	RT	1-way, top right
4		2-way, top right
5	RT/LT	1-way, top right/left
6		2-way, top right/left

Valve terminals type 84 VTOC

Peripherals overview

Overview of electrical connections

Valve terminal with flat cable connection underneath

- Flat cable connection type, code: RC
 - Connection direction:
 - Left (code LB)
- VTOC valve terminals with electrical multi-pin plug connection are available in gradations from 2 to max. 24 valve positions. A valve body occupies one valve position and contains two single solenoid 3/2-way valves.
- A maximum of 48 solenoid coils can therefore be actuated via the electrical multi-pin plug connection.
- A total of 19 pin allocation variants are available.

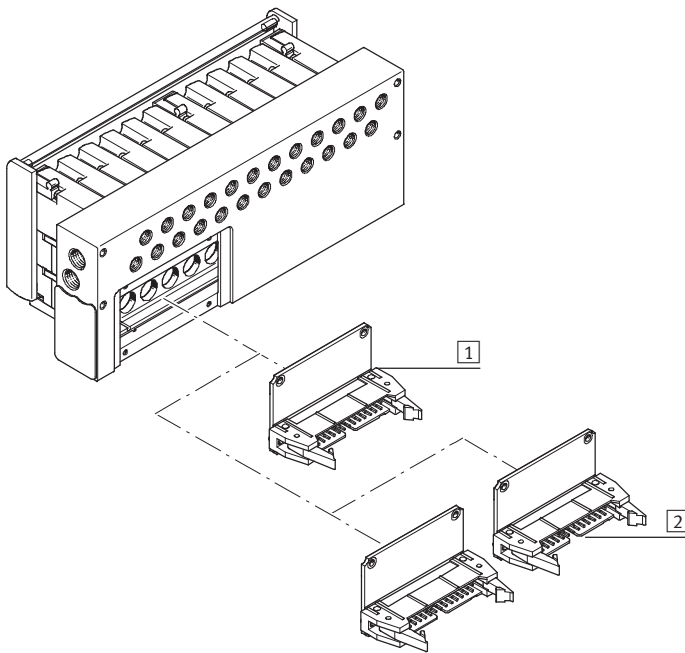

Accessories		
	Code	Brief description
1 Flat cable, 26-pin	LB	1-way, bottom left
2 Flat cable, 26-pin		2-way, bottom left

Valve terminals type 84 VTOC

Peripherals overview

Overview of electrical connections

Valve terminal with Sub-D connection on top

- Sub-D connection type, code: SD
- Connection direction:
 - Left (code LT)
 - Right (code RT)

VTOC valve terminals with electrical multi-pin plug connection are available in gradations from 2 to max. 24 valve positions. A valve body occupies one valve position and contains two single solenoid 3/2-way valves.

A maximum of 48 solenoid coils can therefore be actuated via the electrical multi-pin plug connection.

A total of 19 pin allocation variants are available.

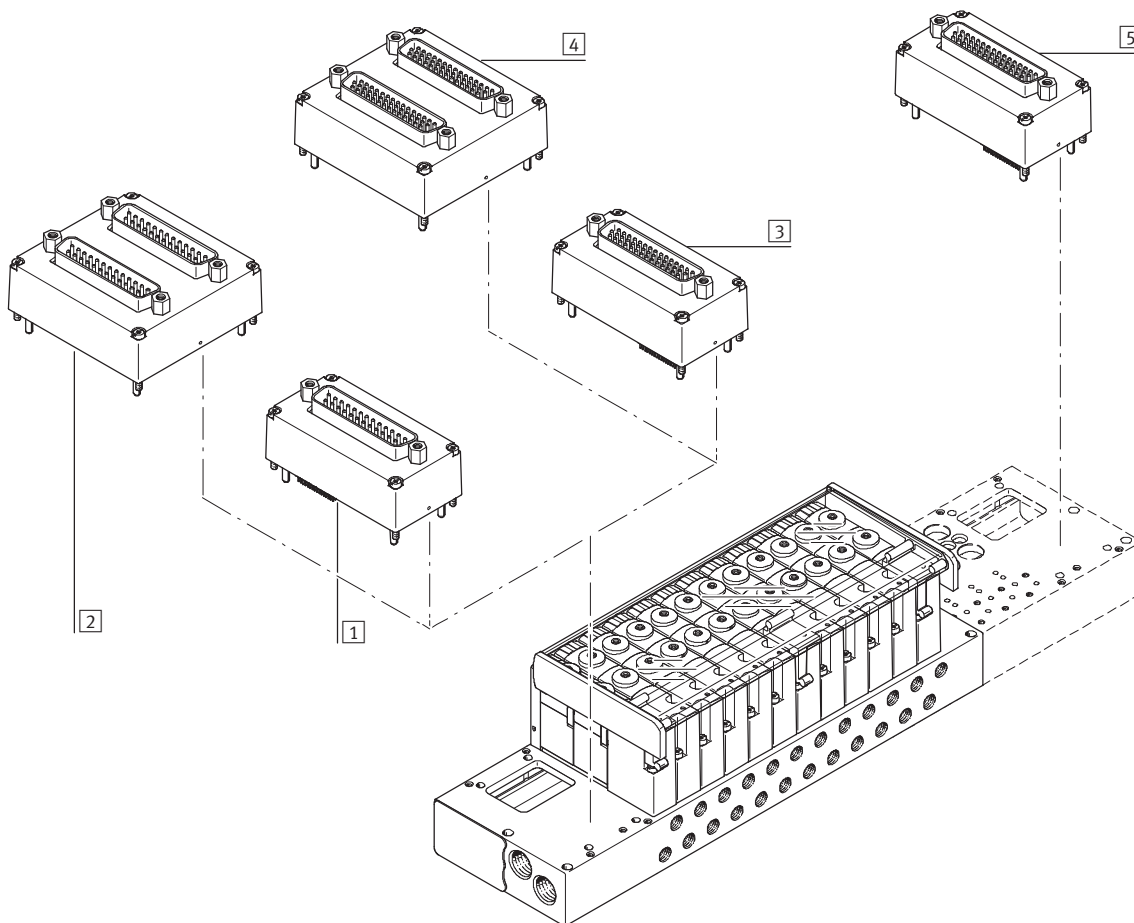

Accessories		
	Code	Brief description
1	LT	1-way, top left
2		2-way, top left
3	LT	1-way, top left
4		2-way, top left
5	RT	1-way, top right

Valve terminals type 84 VTOC

Key features – Pneumatic components

Design

The valves are mounted on the metal manifold rail using two screws. The use of 2x3/2 directional control valves per valve position guarantees optimum use of space with maximum performance. The valves only differ in

the type of manual override. The assembled and tested units or individual components as modules enable a custom configuration.

Blanking plates can be replaced by valves at a later date. The dimensions, mounting points and existing

pneumatic and electrical installations remain unchanged during this process.

Valve function

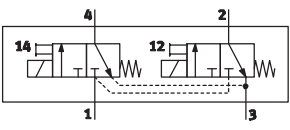
Code	Circuit symbol	Width	Description
		10 mm	
K		■	2x3/2-way valve, single solenoid <ul style="list-style-type: none"> • Mechanical spring return • Non-reversible

Valve terminals type 84 VTOC

Key features – Pneumatic components

Fittings

Port 1/3

Wide range of connection sizes:

- Threaded connection M7, G $\frac{1}{8}$, $\frac{1}{8}$ NPT
- Push-in connector QS-6-, QS-8, QS- $\frac{3}{8}$ or QS- $\frac{1}{4}$ (compressed air supply)
- Push-in connector QS6, QS- $\frac{1}{4}$ or silencer (exhaust air)

Variable connection types for port 1, compressed air supply and port 3, exhaust air:

- Straight
- Push-in L-fitting
- T-fitting

Flexible connection positions for the compressed air supply and exhaust:

- Both sides
- Left-hand
- Right-hand

Port 1/3

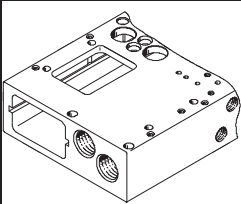
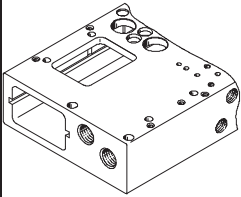
Connection direction: front	Code	Description
	-G18	Manifold block G $\frac{1}{8}$ (diagram shows example of Sub-D electrical connection on left) Basis for design: <ul style="list-style-type: none"> • Push-in connector QS8 • Push-in connector QS-$\frac{3}{8}$"
	-M7	Manifold block M7 (diagram shows example of Sub-D electrical connection on left) Basis for design: <ul style="list-style-type: none"> • Push-in connector QS6 • Push-in connector QS-$\frac{1}{4}$" • Exhaust port via push-in fitting or silencer

Valve terminals type 84 VTOC

Key features – Pneumatic components

Fittings

Port 2/4

Wide range of connection sizes:

- Threaded connection M5
- 10-32 UNF
- Push-in connector QS-3, QS-4 or 1/8"

Outlet direction:

- Front
- Underneath

Connection on the valve (port 2/4)

Outlet direction to the front

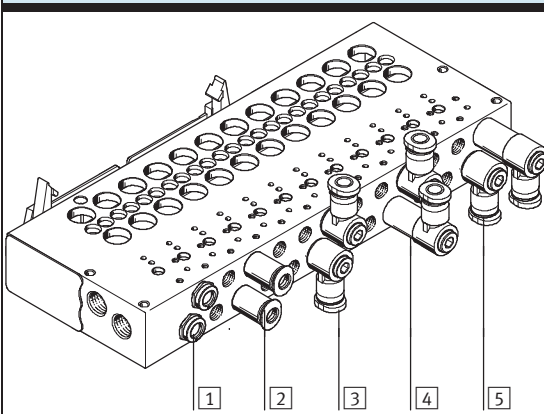

	Code	Description
1	X	Straight countersunk outlet (compact)
2	-	Straight outlet
3	FB	Angled output, upwards/downwards
4	FA	Angled outlet, upwards
5	FC	Angled outlet, downwards

Outlet direction underneath

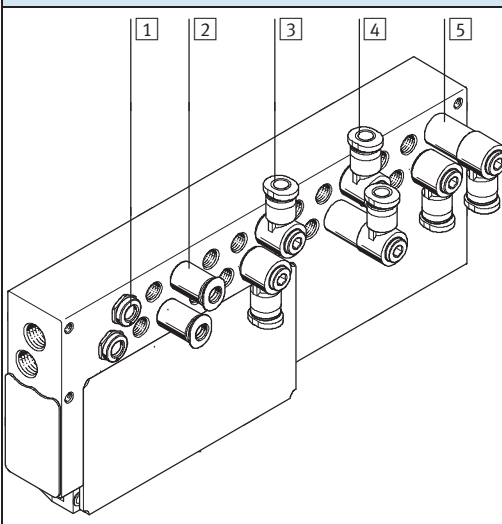

1	X	Straight countersunk outlet (compact)
2	U	Straight outlet
3	UB	Angled outlet, to the front/rear
4	UA	Angled outlet, to the front
5	UC	Angled outlet, to the rear

Valve terminals type 84 VTOC

Key features – Display and operation

Manual override (MO)

Manual override with automatic return (non-detenting)

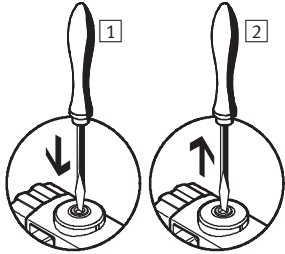

1 Press in the stem of the manual override with a pointed object or screwdriver.
The valve switches.

2 Remove the pointed object or screwdriver.
Spring force pushes the manual override back.
Valve returns to normal position.

Manual override with lock (non-detenting/detenting)

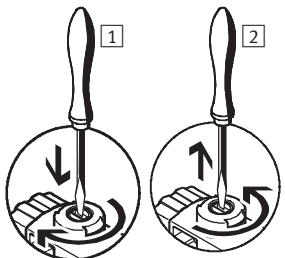

1 Press in the stem of the manual override with a screwdriver until the valve switches and then turn the stem clockwise by 90° until the stop is reached.
The valve remains switched.

2 Turn the stem anti-clockwise by 90° until the stop is reached and then remove the screwdriver.
Spring force pushes the manual override back.
Valve returns to normal position.

 Note

VTOC provides two valves with the same valve function but different types of manual override. There is no provision for subsequent modification of the type of manual override (e.g. by attaching a cover).

Identification system

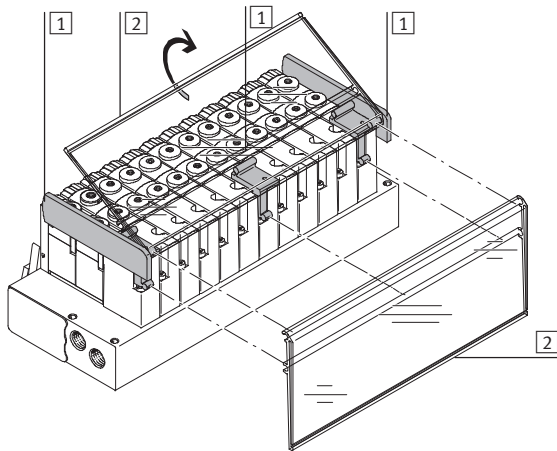

1 Retainer for inscription label holder
The retainer for the inscription label holder is fastened to the valves with one screw and enables the inscription label holder to be mounted in two different directions. The retainers at the side are flanged to prevent the inscription label sliding out.

2 Inscription label holder
A transparent inscription label holder ASCF-H-L2 (code F/T in the order code) can be mounted for labelling the valves.
Inscription labels can be inserted in the holders for labelling purposes. Templates for printing the inscription label are available on request.

Mounting – Valve terminal

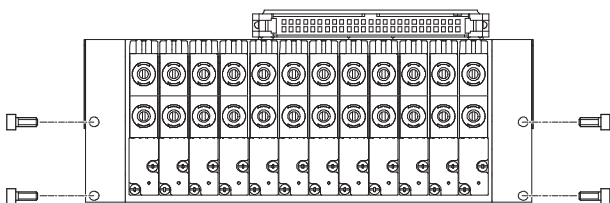

Sturdy terminal mounting thanks to:

- Four through-holes for wall mounting (hole \varnothing : 3.3 mm)
- Four holes with thread on the reverse side:
 - Thread M3
 - Thread M4

- Thread 8-32 UNC
- Thread 10-32 UNC-2B

Valve terminals type 84 VTOC

Key features – Electrical components

Electrical multi-pin plug connection

The following multi-pin plug connections are available for the valve terminal VTOC:

- Sub-D multi-pin plug connection (25-pin, 1-way or 2-way)
- Sub-D multi-pin plug connection (44-pin, 1-way or 2-way)
- Flat cable plug (26-pin, 1-way or 2-way)
- Flat cable plug (40-pin, 1-way or 2-way)
- Flat cable plug (50-pin, 1-way or 2-way)

Connection directions:

- Sub-D connection (top left/right)
- Flat cable (top/bottom left, top/bottom right)

Control signals from the controller to the valve terminal are transmitted via the multi-core pre-assembled cable, which substantially reduces installation time.

The valves are switched by means of positive or negative logic (positive switching or negative switching). Mixed operation is not permitted. Each pin on the multi-pin plug can actuate exactly one solenoid coil. If the maximum configurable number of valve positions is 24, then

48 valves can be addressed with one solenoid coil (single solenoid).

The multi-pin plug connection is available with 19 different pin allocation variants.

Other variants on request.

Pin allocation – Sub-D plug, 25-pin

Pin	-V2		-V3		-V1		-V4				-V12			
	Sub-D A ¹⁾		Sub-D B ²⁾		Sub-D A ¹⁾		Sub-D B ²⁾		Sub-D A ¹⁾		Sub-D B ²⁾			
1	VP1	14	VP1	14-	VP1	12	VP1	14	VP13	14	VP1	14	VP1	14
2	VP2	14	VP2	14-	VP1	14	VP1	12	VP13	12	VP1	12	VP1	12
3	VP3	14	VP3	14-	VP2	12	VP2	14	VP14	14	VP2	14	VP2	14
4	VP4	14	VP4	14-	VP2	14	VP2	12	VP14	12	VP2	12	VP2	12
5	VP5	14	VP5	14-	VP3	12	VP3	14	VP15	14	VP3	14	VP3	14
6	VP6	14	VP6	14-	VP3	14	VP3	12	VP15	12	VP3	12	VP3	12
7	VP7	14	VP7	14-	VP4	12	VP4	14	VP16	14	VP4	14	VP4	14
8	VP8	14	VP8	14-	VP4	14	VP4	12	VP16	12	VP4	12	VP4	12
9	VP9	14	VP9	14-	VP5	12	VP5	14	VP17	14	VP5	14	VP5	14
10	VP10	14	VP10	14-	VP5	14	VP5	12	VP17	12	VP5	12	VP5	12
11	VP11	14	VP11	14-	VP6	12	VP6	14	VP18	14	VP6	14	VP6	14
12	VP12	14	VP12	14-	VP6	14	VP6	12	VP18	12	VP6	12	VP6	12
13	Com		Com+		VP7	12	VP7	14	VP19	14	VP7	14	VP7	14
14	VP1	12	VP1	12-	VP7	14	VP7	12	VP19	12	VP7	12	VP7	12
15	VP2	12	VP2	12-	VP8	12	VP8	14	VP20	14	VP8	14	VP8	14
16	VP3	12	VP3	12-	VP8	14	VP8	12	VP20	12	VP8	12	VP8	12
17	VP4	12	VP4	12-	VP9	12	VP9	14	VP21	14	VP9	14	VP9	14
18	VP5	12	VP5	12-	VP9	14	VP9	12	VP21	12	VP9	12	VP9	12
19	VP6	12	VP6	12-	VP10	12	VP10	14	VP22	14	VP10	14	VP10	14
20	VP7	12	VP7	12-	VP10	14	VP10	12	VP22	12	VP10	12	VP10	12
21	VP8	12	VP8	12-	VP11	12	VP11	14	VP23	14	VP11	14	VP11	14
22	VP9	12	VP9	12-	VP11	14	VP11	12	VP23	12	VP11	12	VP11	12
23	VP10	12	VP10	12-	VP12	12	VP12	14	VP24	14	VP12	14	VP12	14
24	VP11	12	VP11	12-	VP12	14	VP12	12	VP24	12	VP12	12	VP12	12
25	VP12	12	VP12	12-	Com		Com 1-12		Com 13-24		-	-	-	-

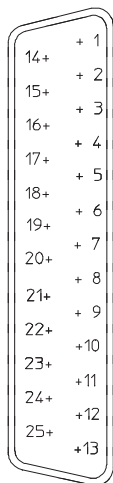

Note
The drawing shows the view onto the Sub-D plug on the valve terminal.

VP Valve position
1) Sub-D A, first Sub-D plug
2) Sub-D B, second Sub-D plug

Valve terminals type 84 VTOC

Key features – Electrical components



Pin allocation – Sub-D plug, 44-pin

Pin	-V5		-V7				-V6				-V13	
			Sub-D A ¹⁾		Sub-D B ²⁾		Sub-D A ¹⁾		Sub-D B ²⁾			
1	VP1	14	VP1	14	VP1	14	VP1	14+	VP1	14-	VP1	12
2	VP1	12	VP1	12	VP1	12	VP1	12+	VP1	12-	VP1	14
3	VP2	14	VP2	14	VP2	14	VP2	14+	VP2	14-	VP2	12
4	VP2	12	VP2	12	VP2	12	VP2	12+	VP2	12-	VP2	14
5	VP3	14	VP3	14	VP3	14	VP3	14+	VP3	14-	VP3	12
6	VP3	12	VP3	12	VP3	12	VP3	12+	VP3	12-	VP3	14
7	VP4	14	VP4	14	VP4	14	VP4	14+	VP4	14-	VP4	12
8	VP4	12	VP4	12	VP4	12	VP4	12+	VP4	12-	VP4	14
9	VP5	14	VP5	14	VP5	14	VP5	14+	VP5	14-	VP5	12
10	VP5	12	VP5	12	VP5	12	VP5	12+	VP5	12-	VP5	14
11	VP6	14	VP6	14	VP6	14	VP6	14+	VP6	14-	VP6	12
12	VP6	12	VP6	12	VP6	12	VP6	12+	VP6	12-	VP6	14
13	VP7	14	VP7	14	VP7	14	VP7	14+	VP7	14-	VP7	12
14	VP7	12	VP7	12	VP7	12	VP7	12+	VP7	12-	VP7	14
15	VP8	14	VP8	14	VP8	14	VP8	14+	VP8	14-	VP8	12
16	VP8	12	VP8	12	VP8	12	VP8	12+	VP8	12-	VP8	14
17	VP9	14	VP9	14	VP9	14	VP9	14+	VP9	14-	VP9	12
18	VP9	12	VP9	12	VP9	12	VP9	12+	VP9	12-	VP9	14
19	VP10	14	VP10	14	VP10	14	VP10	14+	VP10	14-	VP10	12
20	VP10	12	VP10	12	VP10	12	VP10	12+	VP10	12-	VP10	14
21	VP11	14	VP11	14	VP11	14	VP11	14+	VP11	14-	VP11	12
22	VP11	12	VP11	12	VP11	12	VP11	12+	VP11	12-	VP11	14
23	VP12	14	VP12	14	VP12	14	VP12	14+	VP12	14-	VP12	12
24	VP12	12	VP12	12	VP12	12	VP12	12+	VP12	12-	VP12	14
25	VP13	14	VP13	14	VP13	14	VP13	14+	VP13	14-	VP13	12
26	VP13	12	VP13	12	VP13	12	VP13	12+	VP13	12-	VP13	14
27	VP14	14	VP14	14	VP14	14	VP14	14+	VP14	14-	VP14	12
28	VP14	12	VP14	12	VP14	12	VP14	12+	VP14	12-	VP14	14
29	VP15	14	VP15	14	VP15	14	VP15	14+	VP15	14-	VP15	12
30	VP15	12	VP15	12	VP15	12	VP15	12+	VP15	12-	VP15	14
31	VP16	14	VP16	14	VP16	14	VP16	14+	VP16	14-	VP16	12
32	VP16	12	VP16	12	VP16	12	VP16	12+	VP16	12-	VP16	14
33	VP17	14	VP17	14	VP17	14	VP17	14+	VP17	14-	VP17	12
34	VP17	12	VP17	12	VP17	12	VP17	12+	VP17	12-	VP17	14
35	VP18	14	VP18	14	VP18	14	VP18	14+	VP18	14-	VP18	12
36	VP18	12	VP18	12	VP18	12	VP18	12+	VP18	12-	VP18	14
37	VP19	14	VP19	14	VP19	14	VP19	14+	VP19	14-	VP19	12
38	VP19	12	VP19	12	VP19	12	VP19	12+	VP19	12-	VP19	14
39	VP20	14	VP20	14	VP20	14	VP20	14+	VP20	14-	VP20	12
40	VP20	12	VP20	12	VP20	12	VP20	12+	VP20	12-	VP20	14
41	VP21	14	VP21	14	VP21	14	VP21	14+	VP21	14-	Com	
42	VP21	12	VP21	12	VP21	12	VP21	12+	VP21	12-	Com	
43	Com		VP22	14	VP22	14	VP22	14+	VP22	14-	Com	
44	Com		VP22	12	VP22	12	VP22	12+	VP22	12-	Com	

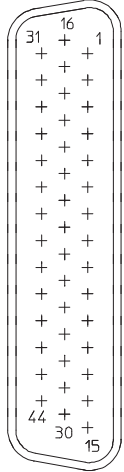

 Note
The drawing shows the view onto the Sub-D plug on the valve terminal.

VP Valve position
1) Sub-D A, first Sub-D plug
2) Sub-D B, second Sub-D plug

Valve terminals type 84 VTOC

Key features – Electrical components



Pin allocation – Flat cable, 26-pin												
Pin	-V14		-V15				-V8		-V17			
			Plug 1		Plug 2				Plug 1		Plug 2	
1	VP1	14	VP1	14	VP13	14	VP1	14	VP12	14	VP24	14
2	VP1	12	VP1	12	VP13	12	VP1	12	VP12	12	VP24	12
3	VP2	14	VP2	14	VP14	14	VP2	14	VP11	14	VP23	14
4	VP2	12	VP2	12	VP14	12	VP2	12	VP11	12	VP23	12
5	VP3	14	VP3	14	VP15	14	VP3	14	VP10	14	VP22	14
6	VP3	12	VP3	12	VP15	12	VP3	12	VP10	12	VP22	12
7	VP4	14	VP4	14	VP16	14	VP4	14	VP9	14	VP21	14
8	VP4	12	VP4	12	VP16	12	VP4	12	VP9	12	VP21	12
9	VP5	14	VP5	14	VP17	14	VP5	14	VP8	14	VP20	14
10	VP5	12	VP5	12	VP17	12	VP5	12	VP8	12	VP20	12
11	VP6	14	VP6	14	VP18	14	VP6	14	VP7	14	VP19	14
12	VP6	12	VP6	12	VP18	12	VP6	12	VP7	12	VP19	12
13	VP7	14	VP7	14	VP19	14	VP7	14	VP6	14	VP18	14
14	VP7	12	VP7	12	VP19	12	VP7	12	VP6	12	VP18	12
15	VP8	14	VP8	14	VP20	14	VP8	14	VP5	14	VP17	14
16	VP8	12	VP8	12	VP20	12	VP8	12	VP5	12	VP17	12
17	VP9	14	VP9	14	VP21	14	VP9	14	VP4	14	VP16	14
18	VP9	12	VP9	12	VP21	12	VP9	12	VP4	12	VP16	12
19	VP10	14	VP10	14	VP22	14	VP10	14	VP3	14	VP15	14
20	VP10	14	VP10	14	VP22	12	VP10	14	VP3	12	VP15	12
21	VP11	14	VP11	14	VP23	14	VP11	14	VP2	14	VP14	14
22	VP11	12	VP21	12	VP23	12	VP11	12	VP2	12	VP14	12
23	VP12	14	VP12	14	VP24	14	VP12	14	VP1	14	VP13	14
24	VP12	12	VP12	12	VP24	12	VP12	12	VP1	12	VP13	12
25	Com		Com		Com		Com		Com		Com	
26	Com		Com		Com		Com		Com		Com	

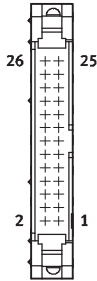

- - Note
The drawing shows the view onto the flat cable plug on the valve terminal.

VP Valve position

Valve terminals type 84 VTOC

Key features – Electrical components



Pin allocation – Flat cable, 40-pin

Pin	-V9		-V18			
			Plug 1		Plug 2	
1	VP10	12+	VP10	12+	VP11	14+
2	VP10	12-	VP10	12-	VP11	14-
3	VP10	14+	VP10	14+	VP11	12+
4	VP10	14-	VP10	14-	VP11	12-
5	VP9	12+	VP9	12+	VP12	14+
6	VP9	12-	VP9	12-	VP12	14-
7	VP9	14+	VP9	14+	VP12	12+
8	VP9	14-	VP9	14-	VP12	12-
9	VP8	12+	VP8	12+	VP13	14+
10	VP8	12-	VP8	12-	VP13	14-
11	VP8	14+	VP8	14+	VP13	12+
12	VP8	14-	VP8	14-	VP13	12-
13	VP7	12+	VP7	12+	VP14	14+
14	VP7	12-	VP7	12-	VP14	14-
15	VP7	14+	VP7	14+	VP14	12+
16	VP7	14-	VP7	14-	VP14	12-
17	VP6	12+	VP6	12+	VP15	14+
18	VP6	12-	VP6	12-	VP15	14-
19	VP6	14+	VP6	14+	VP15	12+
20	VP6	14-	VP6	14-	VP15	12-
21	VP5	12+	VP5	12+	VP16	14+
22	VP5	12-	VP5	12-	VP16	14-
23	VP5	14+	VP5	14+	VP16	12+
24	VP5	14-	VP5	14-	VP16	12-
25	VP4	12+	VP4	12+	VP17	14+
26	VP4	12-	VP4	12-	VP17	14-
27	VP4	14+	VP4	14+	VP17	12+
28	VP4	14-	VP4	14-	VP17	12-
29	VP3	12+	VP3	12+	VP18	14+
30	VP3	12-	VP3	12-	VP18	14-
31	VP3	14+	VP3	14+	VP18	12+
32	VP3	14-	VP3	14-	VP18	12-
33	VP2	12+	VP2	12+	VP19	14+
34	VP2	12-	VP2	12-	VP19	14-
35	VP2	14+	VP2	14+	VP19	12+
36	VP2	14-	VP2	14-	VP19	12-
37	VP1	12+	VP1	12+	VP20	14+
38	VP1	12-	VP1	12-	VP20	14-
39	VP1	14+	VP1	14+	VP20	12+
40	VP1	14-	VP1	14-	VP20	12-

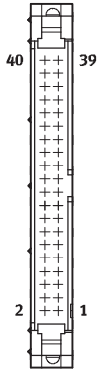

 Note

The drawing shows the view onto the flat cable plug on the valve terminal.

VP Valve position

Valve terminals type 84 VTOC

Key features – Electrical components



Pin allocation – Flat cable, 50-pin

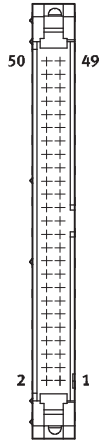

Pin	-V11		-V16				-V10		-V19			
			Plug 1		Plug 2				Plug 1		Plug 2	
1	VP1	12	VP1	12	VP24	12	VP12	12	VP12	12	VP13	12
2	VP1	12	VP1	12	VP24	12	VP12	12	VP12	12	VP13	12
3	VP1	14	VP1	14	VP24	14	VP12	14	VP12	14	VP13	14
4	VP1	14	VP1	14	VP24	14	VP12	14	VP12	14	VP13	14
5	VP2	12	VP2	12	VP23	12	VP11	12	VP11	12	VP14	12
6	VP2	12	VP2	12	VP23	12	VP11	12	VP11	12	VP14	12
7	VP2	14	VP2	14	VP23	14	VP11	14	VP11	14	VP14	14
8	VP2	14	VP2	14	VP23	14	VP11	14	VP11	14	VP14	14
9	VP3	12	VP3	12	VP22	12	VP10	12	VP10	12	VP15	12
10	VP3	12	VP3	12	VP22	12	VP10	12	VP10	12	VP15	12
11	VP3	14	VP3	14	VP22	14	VP10	14	VP10	14	VP15	14
12	VP3	14	VP3	14	VP22	14	VP10	14	VP10	14	VP15	14
13	VP4	12	VP4	12	VP21	12	VP9	12	VP9	12	VP16	12
14	VP4	12	VP4	12	VP21	12	VP9	12	VP9	12	VP16	12
15	VP4	14	VP4	14	VP21	14	VP9	14	VP9	14	VP16	14
16	VP4	14	VP4	14	VP21	14	VP9	14	VP9	14	VP16	14
17	VP5	12	VP5	12	VP20	12	VP8	12	VP8	12	VP17	12
18	VP5	12	VP5	12	VP20	12	VP8	12	VP8	12	VP17	12
19	VP5	14	VP5	14	VP20	14	VP8	14	VP8	14	VP17	14
20	VP5	14	VP5	14	VP20	14	VP8	14	VP8	14	VP17	14
21	VP6	12	VP6	12	VP19	12	VP7	12	VP7	12	VP18	12
22	VP6	12	VP6	12	VP19	12	VP7	12	VP7	12	VP18	12
23	VP6	14	VP6	14	VP19	14	VP7	14	VP7	14	VP18	14
24	VP6	14	VP6	14	VP19	14	VP7	14	VP7	14	VP18	14
25	VP7	12	VP7	12	VP18	12	VP6	12	VP6	12	VP19	12
26	VP7	12	VP7	12	VP18	12	VP6	12	VP6	12	VP19	12
27	VP7	14	VP7	14	VP18	14	VP6	14	VP6	14	VP19	14
28	VP7	14	VP7	14	VP18	14	VP6	14	VP6	14	VP19	14
29	VP8	12	VP8	12	VP17	12	VP5	12	VP5	12	VP20	12
30	VP8	12	VP8	12	VP17	12	VP5	12	VP5	12	VP20	12
31	VP8	14	VP8	14	VP17	14	VP5	14	VP5	14	VP20	14
32	VP8	14	VP8	14	VP17	14	VP5	14	VP5	14	VP20	14
33	VP9	12	VP9	12	VP16	12	VP4	12	VP4	12	VP21	12
34	VP9	12	VP9	12	VP16	12	VP4	12	VP4	12	VP21	12
35	VP9	14	VP9	14	VP16	14	VP4	14	VP4	14	VP21	14
36	VP9	14	VP9	14	VP16	14	VP4	14	VP4	14	VP21	14
37	VP10	12	VP10	12	VP15	12	VP3	12	VP3	12	VP22	12
38	VP10	12	VP10	12	VP15	12	VP3	12	VP3	12	VP22	12
39	VP10	14	VP10	14	VP15	14	VP3	14	VP3	14	VP22	14
40	VP10	14	VP10	14	VP15	14	VP3	14	VP3	14	VP22	14
41	VP11	12	VP11	12	VP14	12	VP2	12	VP2	12	VP23	12
42	VP11	12	VP11	12	VP14	12	VP2	12	VP2	12	VP23	12
43	VP11	14	VP11	14	VP14	14	VP2	14	VP2	14	VP23	14
44	VP11	14	VP11	14	VP14	14	VP2	14	VP2	14	VP23	14
45	VP12	12	VP12	12	VP13	12	VP1	12	VP1	12	VP24	12
46	VP12	12	VP12	12	VP13	12	VP1	12	VP1	12	VP24	12
47	VP12	14	VP12	14	VP13	14	VP1	14	VP1	14	VP24	14
48	VP12	14	VP12	14	VP13	14	VP1	14	VP1	14	VP24	14
49	-	-	-	-	-	-	-	-	-	-	-	-
50	-	-	-	-	-	-	-	-	-	-	-	-



- - Note
The drawing shows the view onto the flat cable plug on the valve terminal.

VP Valve position

Valve terminals type 84 VTOC

FESTO

Technical data

-  Voltage
24 V DC
-  Pressure
0 ... +8 bar
-  Temperature range
-5 ... +50 °C

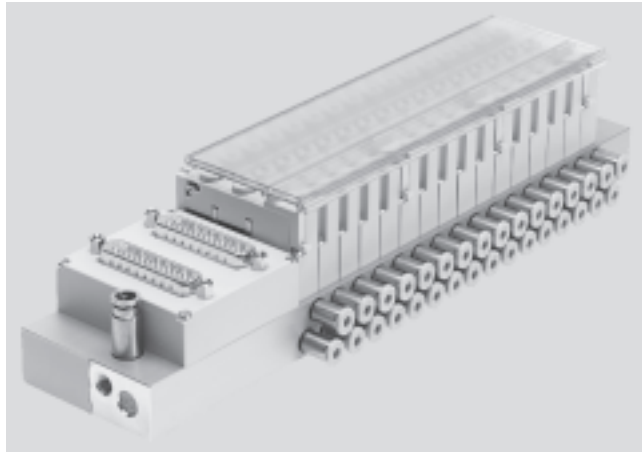

General technical data	
Valve function	2x3/2-way valve, single solenoid, closed
Design	Poppet valve with spring return
Sealing principle	Soft
Actuation type	Electrical
Reset method	Mechanical spring
Type of control	Direct
Direction of flow	Non-reversible
Exhaust function	No flow control
Manual override	Non-detenting, detenting and non-detenting
Type of mounting	Via through-hole or thread
Width	[mm] 10
Nominal size	[mm] 0.65
Max. number of valve positions	24
Standard nominal flow rate	qnN [l/min] 10

Operating and environmental conditions	
Operating medium	Dried and filtered compressed air, lubricated or unlubricated, grade of filtration 40 µm
Operating pressure	[bar] 0 ... +8
Ambient temperature	[°C] -5 ... +50
Temperature of medium	[°C] +5 ... +50
Note on materials	RoHS-compliant

Product weight	
Approx. weight	[g]
Valve	30
Blanking plate for vacant position	20

Electrical data	
Electrical actuation	Multi-pin plug (Sub-D/flat cable)
Nominal operating voltage	[V DC] 24
Permissible voltage fluctuations	[%] ±10
Protection class to EN 60529	IP40
Duty cycle	[%] 100

Valve switching times	
	[ms]
On	4.7
Off	5.2

Valve terminals type 84 VTOC

Technical data

Dimensions – Sub-D, single or double

Download CAD data → www.festo.com

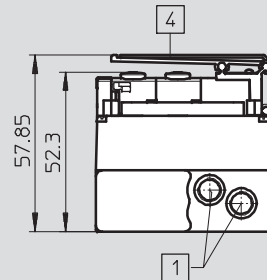
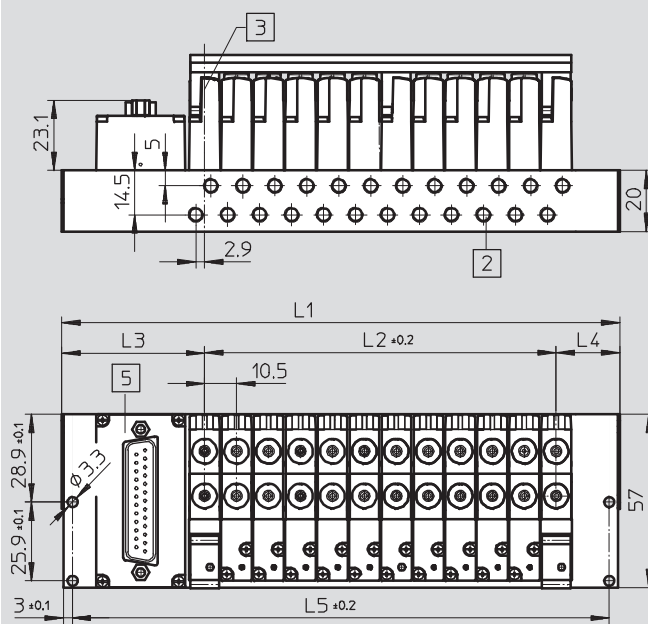

- 1 Ports 1 and 3, left and right, M7 or G1/8
- 2 Ports 2 and 4, front or underneath, M5 or 10-32 UNF
- 3 Centre of first valve position
- 4 Inscription label
- 5 Electrical connection via Sub-D, single or double (left or right)

	Comment	Electrical connection on top, single			Electrical connection on top, double		
Pneumatic connection	–	M7	G1/8	G1/8	M7	G1/8	G1/8
Through-hole	–	∅ 3.3	∅ 3.3	M4	∅ 3.3	∅ 3.3	M4
L1	–	L2+L3+L4	L2+L3+L4	L2+L3+L4	L2+L3+L4	L2+L3+L4	L2+L3+L4
L2	–	(n-1)×10.5	(n-1)×10.5	(n-1)×10.5	(n-1)×10.5	(n-1)×10.5	(n-1)×10.5
L3	Distance from centre of first valve position to outer edge on left-hand side	41.4	46.4	36.9	66.4	71.4	66.4
	Sub-D connection, 44-pin, top right, 1-way: Distance from centre of first valve position to outer edge on left-hand side	14.4	20.4	20.4	–	–	–
L4	Distance from centre of last valve position to outer edge on right-hand side	14.4	20.4	20.4	–	–	–
	Sub-D connection, 44-pin, top right, 1-way: Distance from centre of last valve position to outer edge on right-hand side	41.4	46.4	36.9	–	–	–
L5	–	(L1-6)	(L1-6)	(L1-6)	(L1-6)	(L1-6)	(L1-6)

Valve terminals type 84 VTOC

Technical data

FESTO

Dimensions – Flat cable on top

Download CAD data → www.festo.com

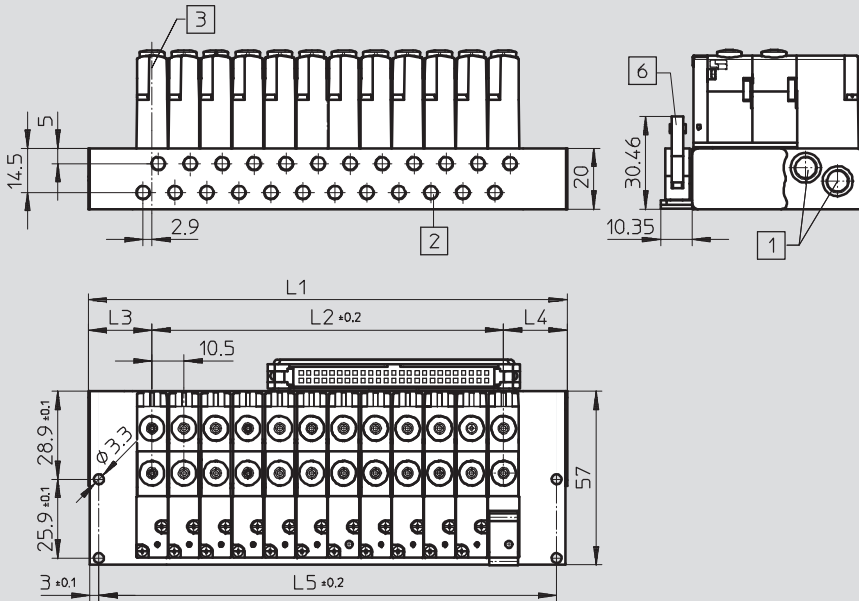

- 1 Ports 1 and 3, left and right, M7 or G $\frac{1}{8}$
- 2 Ports 2 and 4, front or underneath, M5 or 10-32 UNF
- 3 Centre of first valve position
- 6 Electrical connection via flat cable

	Comment			
Pneumatic connection	–	M7	G $\frac{1}{8}$	G $\frac{1}{8}$
Through-hole	–	∅ 3.3	∅ 3.3	M4
L1	–	L2+L3+L4	L2+L3+L4	L2+L3+L4
L2	–	(n-1)×10.5	(n-1)×10.5	(n-1)×10.5
L3	Distance from centre of first valve position to outer edge on left-hand side	41.4	46.4	36.9
L4	Distance from centre of last valve position to outer edge on right-hand side	14.4	20.4	20.4
L5	–	(L1-6)	(L1-6)	(L1-6)

Valve terminals type 84 VTOC

Technical data

Dimensions – Flat cable underneath

Download CAD data → www.festo.com

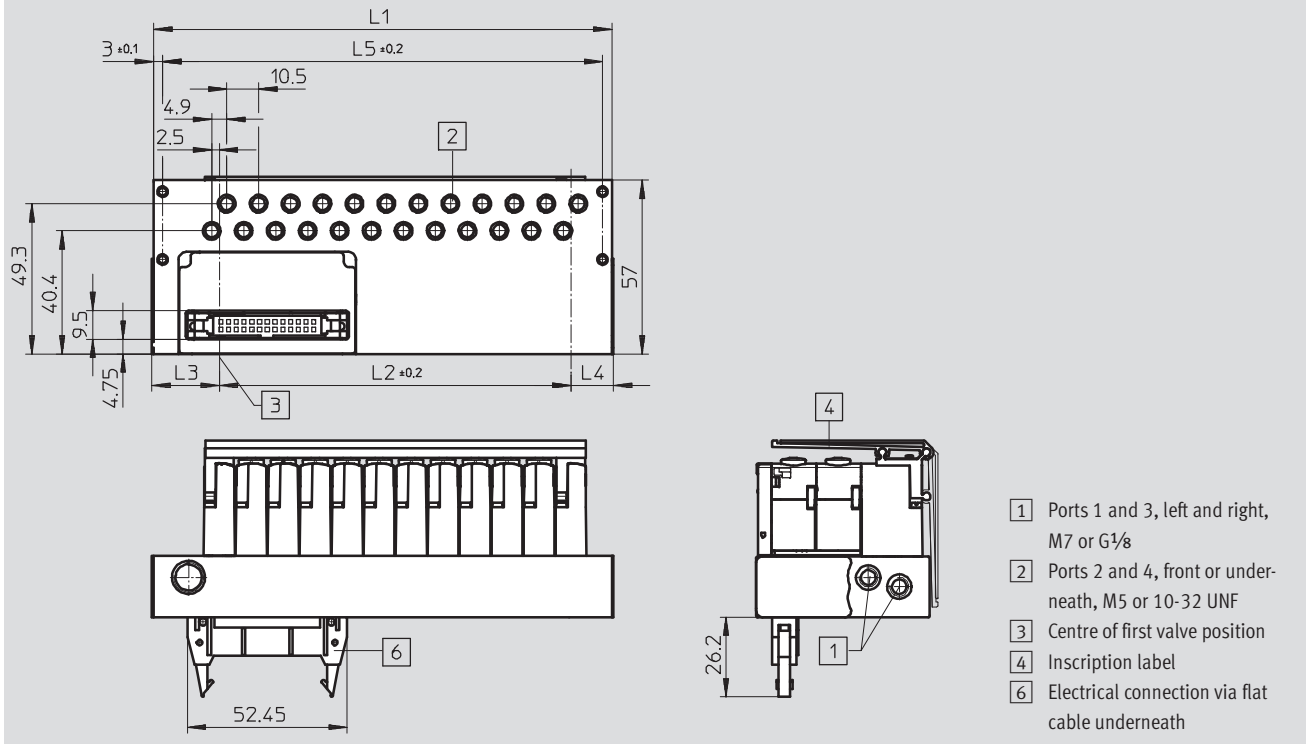

- 1 Ports 1 and 3, left and right, M7 or G $\frac{1}{8}$
- 2 Ports 2 and 4, front or underneath, M5 or 10-32 UNF
- 3 Centre of first valve position
- 4 Inscription label
- 6 Electrical connection via flat cable underneath

	Comment					
Pneumatic connection	–	M7 left	M7 front	G $\frac{1}{8}$ front	G $\frac{1}{8}$ left	G $\frac{1}{8}$ left
Through-hole	–	∅ 3.3	∅ 3.3	∅ 3.3	∅ 3.3	M4
L1	–	L2+L3+L4	L2+L3+L4	L2+L3+L4		
L2	–	(n-1)x10.5	(n-1)x10.5	(n-1)x10.5		
L3	Distance from centre of first valve position to outer edge on left-hand side	14.4	25.55	21.6	20.4	20.4
L4	Distance from centre of last valve position to outer edge on right-hand side	14.4	28.55	20.4	20.4	20.4
L5	–	(L1-6)	(L1-6)	(L1-6)	(L1-6)	(L1-6)

Valve terminals type 84 VTOC

Technical data

FESTO

Dimensions – Pneumatic connections

Download CAD data → www.festo.com

Ports 2 and 4 underneath, M5 (10-32 UNF)

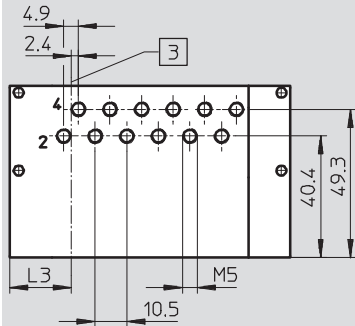

3 Centre of first valve position

Ports 2 and 4 underneath, compact

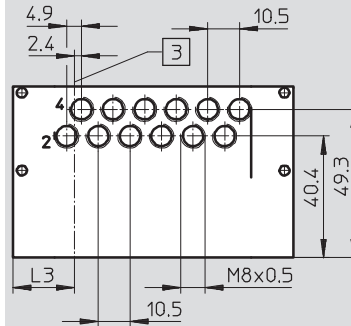

3 Centre of first valve position

Ports 2 and 4 at front, M5 (10-32 UNF)

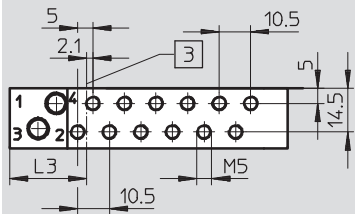

3 Centre of first valve position

Ports 2 and 4 at front, compact

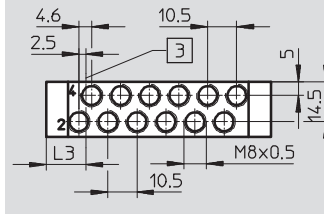

3 Centre of first valve position

Ports 1 and 3, M7 left

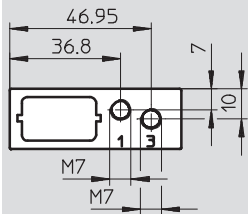

Ports 1 and 3, G1/8 left

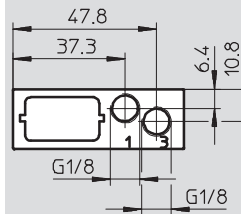

Ports 1 and 3, G1/8, left with mounting hole M4

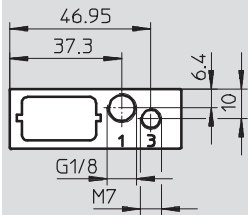

Valve terminals type 84 VTOC

Technical data

FESTO

Dimensions – Mounting hole

Download CAD data → www.festo.com

∅ 3.3 underneath, ports 1 and 3, M7

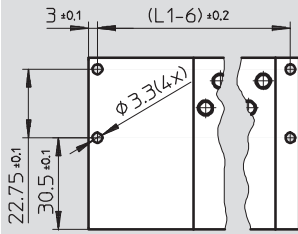

∅ 3.3 underneath, ports 1 and 3, G1/8

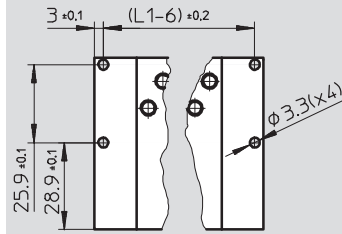

M3 underneath, ports 1 and 3, M7

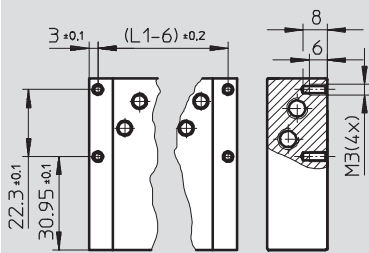

M3 underneath, ports 1 and 3, G1/8

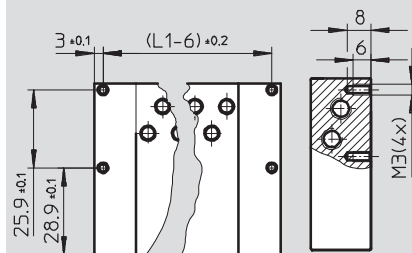

M4 underneath, ports 1 and 3, M7

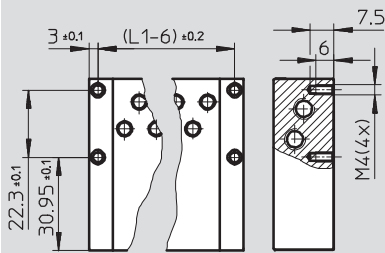

M4 or 8-32UNC underneath, ports 1 and 3, G1/8

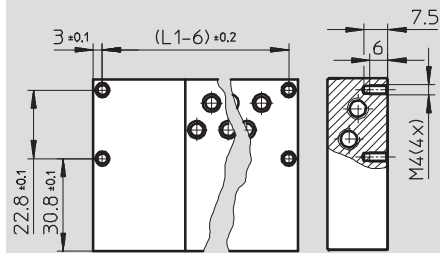

8-32UNC underneath, ports 1 and 3, M7

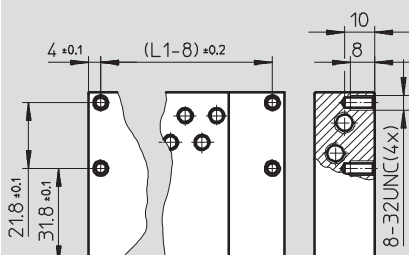

8-32UNC underneath, ports 1 and 3, G1/8

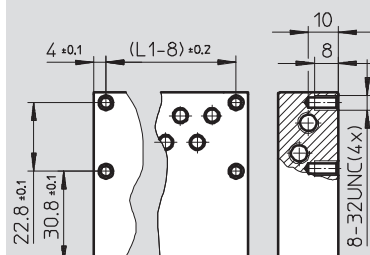

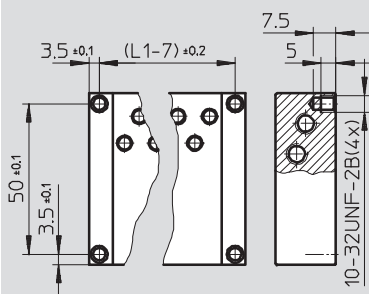

10-32UNF-2B underneath, ports 1 and 3, M7 or G1/8



Valve terminals type 84 VTOC

Accessories

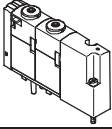
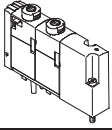
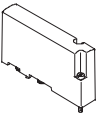

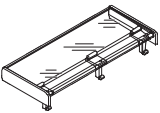
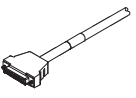
FESTO

Ordering data				
	Code	Valve function	Part No.	Type
Solenoid valves				
	K	2x3/2-way valve, single solenoid, normally closed, non-detenting manual override	565450	VOVC-BT-T32C-MT-F-1T1
	K	2x3/2-way valve, single solenoid, normally closed, detenting, non-detenting/detenting manual override	565449	VOVC-BT-T32C-MH-F-1T1
Blanking plate				
	L	Blanking plate for vacant position	565451	VABB-L2-P3
Blanking plug				
	-	For sealing the air supply or exhaust port	3568	B-1/8
			174309	B-M7
Inscription label holder				
	-	Inscription label holder for identifying the valves	3 valve positions	565571 ASCF-H-L2-3V
			4 valve positions	565572 ASCF-H-L2-4V
			5 valve positions	565573 ASCF-H-L2-5V
			6 valve positions	565574 ASCF-H-L2-6V
			7 valve positions	565575 ASCF-H-L2-7V
			8 valve positions	565576 ASCF-H-L2-8V
			9 valve positions	565577 ASCF-H-L2-9V
			10 valve positions	565578 ASCF-H-L2-10V
			11 valve positions	565579 ASCF-H-L2-11V
			12 valve positions	565580 ASCF-H-L2-12V
			13 valve positions	565581 ASCF-H-L2-13V
			14 valve positions	565582 ASCF-H-L2-14V
			15 valve positions	565583 ASCF-H-L2-15V
			16 valve positions	565584 ASCF-H-L2-16V
			17 valve positions	565585 ASCF-H-L2-17V
			18 valve positions	565586 ASCF-H-L2-18V
		19 valve positions	565587 ASCF-H-L2-19V	
		20 valve positions	565588 ASCF-H-L2-20V	
		21 valve positions	565589 ASCF-H-L2-21V	
		22 valve positions	565590 ASCF-H-L2-22V	
		23 valve positions	565591 ASCF-H-L2-23V	
		24 valve positions	565592 ASCF-H-L2-24V	
Connecting cable				
	-	Sub-D, 25-pin, 15-wire cable	2.5 m	530049 KMP6-25P-12-2,5
			5 m	530050 KMP6-25P-12-5
			10 m	530051 KMP6-25P-12-10
		Sub-D, 25-pin, 25-wire cable	2.5 m	530046 KMP6-25P-20-2,5
			5 m	530047 KMP6-25P-20-5
			10 m	530048 KMP6-25P-20-10

Valve terminals type 84 VTOC

Accessories

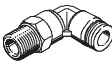
FESTO

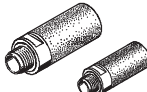
Ordering data						
	Code	Description	Tubing O.D.	Packaging unit	Part No.	Type
Push-in fittings						Technical data → Internet: quick star
	-	QS push-in fitting	1/4"	1 piece	183741	QS-1/8-1/4-I-U-M
			3/8"	1 piece	190679	QS-1/8-3/8-U
			8 mm	10 pieces	153015	QS-1/8-8-I
			6 mm	10 pieces	153321	QSM-M7-6-I
			1/4"	1 piece	183740	QSM-M7-1/4-I-U-M
			1/8"	10 pieces	183749	QSM-M5-1/8-I-U-M
			5/32"	10 pieces	130593	QSM-M5-5/32-I-U-M
			3 mm	10 pieces	153313	QSM-M5-3-I
	-	Push-in L-fitting	8 mm	20 pieces	130928	QSL-B-1/8-8-20
			3/16	1 piece	533234	QSL-H-1/8-3/16-U-M
			1/4	1 piece	533235	QSL-H-1/8-1/4-U-M
			3/8	1 piece	562578	QSL-H-1/8-3/8-U-M
			3 mm	10 pieces	130830	QSMLV-M5-3-I
			4 mm	10 pieces	130831	QSMLV-M5-4-I
	-	Push-in L-fitting, long	3 mm	10 pieces	130834	QSMLLV-M5-3-I
			4 mm	10 pieces	130835	QSMLLV-M5-4-I
	-	T-fitting	1/4	1 piece	533254	QST-H-1/8-1/4-U-M
			3/8	1 piece	562579	QST-H-1/8-3/8-U-M
					132412	QST-H-1/8-3/8-U-MP
			8 mm	20 pieces	130940	QST-B-1/8-8-20
Silencer						Technical data → Internet: quick star
	U	Silencer	-	1 piece	161418	UC-M7
				50 pieces	534218	UC-M7-50