

Pressure sensors SDE5



Pressure sensors SDE5

Key features

FESTO

At a glance

SDE5-...-M8
Plug version, plug M8x1,
3-pin



SDE5-...-K
Cable version, 2.5 m long,
3-wire



Linkable wall bracket with clip-in facility for sensors
(included in the scope of delivery)

Product description

The pressure sensor SDE5 is a cost-effective alternative for simple and quick pressure monitoring. The “intelligent fitting” delivers instant information about the current pressure and is an equally effective device for object detection via back pressure as it is for pressure, regulation and vacuum detection.

Main applications

The pressure sensor SDE5 can be used wherever simple sensing of the current pressure is required:

- Compressed air monitoring
- Regulator monitoring
- Suction confirmation in vacuum technology
- Object detection via back pressure

Features

- Selectable output functions
- Teach-in function for programming
- Minimal assembly times thanks to QS fittings and linkable wall bracket
- Quick switching-point adjustment at the touch of a button
- Switching status indicated by an LED visible from all sides
- Relative pressure or differential pressure measurement
- Five pressure measuring ranges: 0 ... -1, -1 ... 1, 0 ... 2, 0 ... 6, 0 ... 10 bar
- Analogue output: 0 ... 10 V
- Electrical outputs: 1 switching output PNP or NPN

Pressure sensors SDE5

Key features

Application examples

Vacuum monitoring

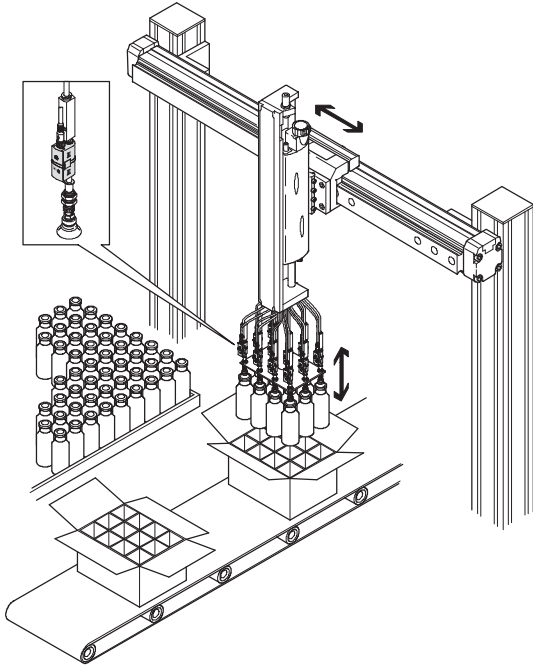

- Pressure sensor SDE5 in combination with a vacuum generator VN for vacuum monitoring in the handling of bottles

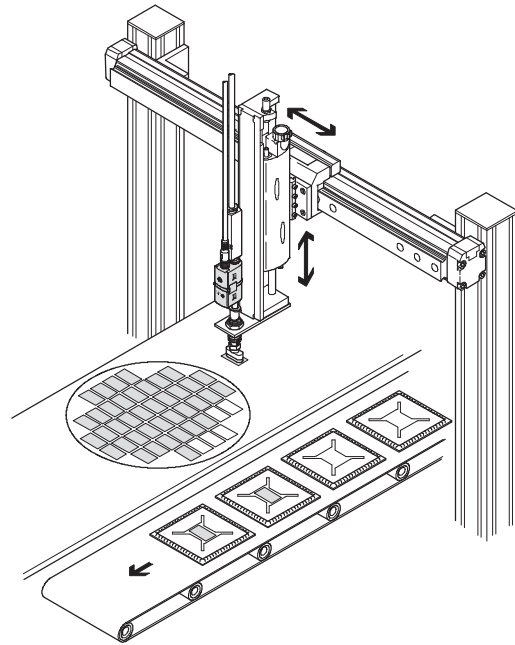

- Pressure sensor SDE5 as suction monitoring in the handling of small parts, such as computer chips

Pressure monitoring

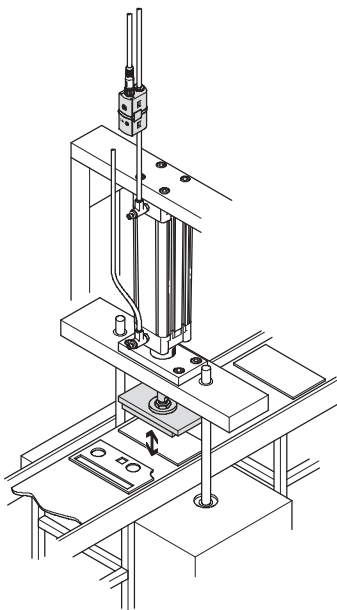

- Pressure sensor SDE5 as pressure monitor for the pressing in of punched parts

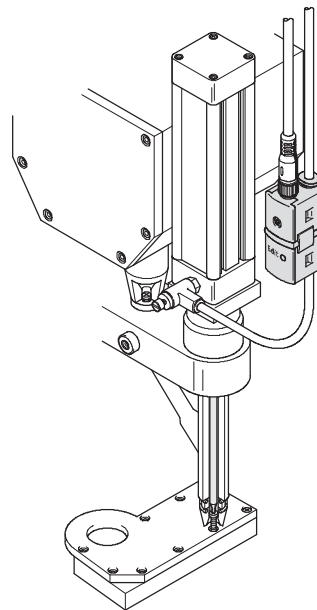

- Pressure sensor SDE5 as "inline variant" for pressure range monitoring on a compressed air screw driver

Pressure sensors SDE5

Peripherals overview

Peripherals overview

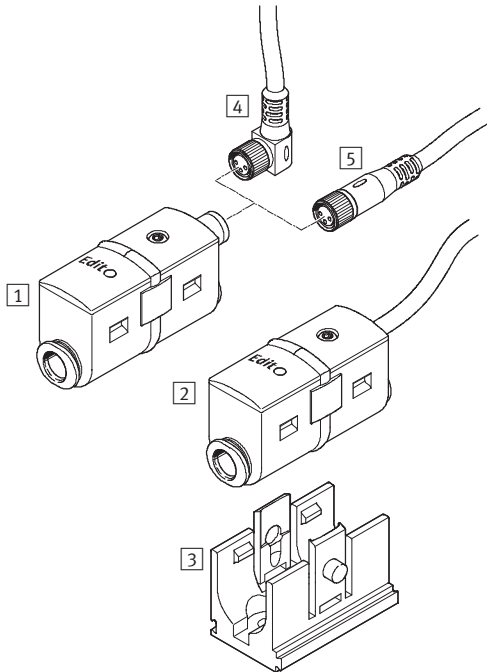

Mounting attachments and accessories		→ Page/Internet
1	Pressure sensor SDE5-...-M8, plug version	-
2	Pressure sensor SDE5-...-K, cable version	-
3	Wall bracket (included in scope of delivery)	-
4	Connecting cable NEBU-M8W3 with angled plug socket	11
5	Connecting cable NEBU-M8G3 with straight plug socket	11

Pressure sensors SDE5

Type codes

		SDE5	-	D10	-	Z	-	FP	-	Q6	-	P	-	M8	
Type															
SDE5	Pressure sensor														
Pressure measuring range															
V1	0 ... -1 bar														
D2	0 ... +2 bar														
D10	0 ... +10 bar														
Pressure input															
	Relative pressure														
Z	Differential pressure														
Output function															
Freely programmable															
FP	Selectable														
Threshold value with fixed hysteresis, 1 teach-in pressure															
O	N/O contact														
C	N/C contact														
Threshold value with fixed hysteresis, 2 teach-in pressures															
O1	N/O contact														
Threshold value with variable hysteresis, 2 teach-in pressures															
O2	N/O contact														
Window comparator with fixed hysteresis, 2 teach-in pressures															
O3	N/O contact														
C3	N/C contact														
Analogue output (no binary switching function)															
NF	Analogue output 0 ... 10 V														
Pneumatic connection															
Push-in connector at both ends															
Q4	For tubing O.D. 4 mm														
Q6	For tubing O.D. 6 mm														
Push-in connector at one end															
Q4E	For tubing O.D. 4 mm														
Q6E	For tubing O.D. 6 mm														
T14E	For tubing O.D. 1/4"														
Electrical output															
P	1 switching output PNP														
N	1 switching output NPN														
V	1 analogue output 0 ... 10 V														
Electrical connection															
K	Cable, 2.5 m long, 3-wire														
M8	Plug, M8x1, 3-pin														

Additional variants can be ordered using the modular system → 10

- Pressure measuring range
- Output function
- Pneumatic connection
- Electrical accessories
- X teach-in point permanently set/negative
- Y teach-in point permanently set/negative

Pressure sensors SDE5

Technical data

Function

Switching output PNP

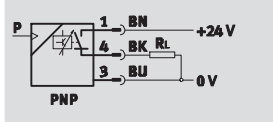

Analogue output

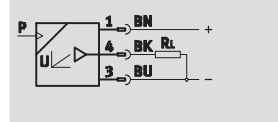

Switching output NPN

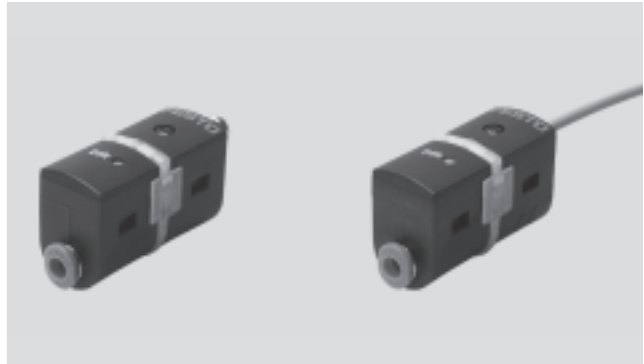
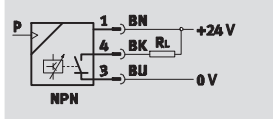

General technical data					
Type SDE5	-V1	-B2	-D2	-D6	-D10
General information					
Certification	C tick cULus recognized (OL)				
CE mark (see declaration of conformity)	To EU EMC Directive				
Note on materials	RoHS-compliant				
Input signal/measuring element					
Measured variable	Relative pressure Differential pressure				
Method of measurement	Piezoresistive pressure sensor				
Pressure measuring range [bar]	0 ... -1	-1 ... +1	0 ... +2	0 ... +6	0 ... +10
Operating medium	Filtered compressed air, lubricated or unlubricated, grade of filtration 40 µm				
Temperature of medium [°C]	0 ... +50				
Ambient temperature [°C]	0 ... +50				

Electrical data		
Output, general ¹⁾		
Repetition accuracy ±FS [%]		0.3
Temperature coefficient ±FS/K [%]		0.05
Switching output		
Accuracy [%]		0.5
Switching output ±FS ¹⁾		
Switching output		PNP NPN
Switching function		Freely programmable (switching/teach-in function, N/O contact, N/C contact) Threshold value with fixed hysteresis Threshold value with variable hysteresis Window comparator with fixed hysteresis
Switching element function		N/C contact N/O contact Switchable
Max. output current [mA]		100
Voltage drop [V]		Max. 1.8
Inductive protective circuit		Adapted to MZ, MY, ME coils
Analogue output		
Output characteristic curve [V]		0 ... 10
Accuracy [%]		3 (ambient temperature 20 ... +25 °C)
Analogue output ±FS ¹⁾		4 (ambient temperature 0 ... +50 °C)
Linearity error ±FS ¹⁾ [%]		0.3

1) % FS = % of the measuring range final value (full-scale)

Pressure sensors SDE5

Technical data

FESTO

Electrical data	
Output, additional data	
Protection against short circuit	Yes
Electronics	
Operating voltage range DC [V]	15 ... 30
Protection against polarity reversal	For all electrical connections
Electromechanics	
Electrical connection	Plug M8x1, 3-pin, round design, to EN 60947-5-2 Cable 2.5 m. 3-wire, to EN 60947-5-2

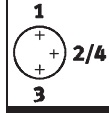
Pin allocation		
Plug, M8x1, 3-pin	Pin	Meaning
	1	Operating voltage +24 V DC
	2/4	Switching output or analogue output
	3	0 V

Mechanics	
Type of mounting	Via accessories
Mounting position	Any
Pneumatic connection	QS-4 QS-6 QS-1/4" QS-5/32"
Product weight [g]	19 (plug version) 47 (cable version)
Product weight of wall bracket [g]	5.5
Material of housing	PA POM

Display/operation	
Switching output	
Switching status display	Yellow LED
Threshold value setting range [%]	0 ... 100
Analogue output	
Ready status display	Green LED

Immissions/emissions	
Storage temperature [°C]	-20 ... +80
Protection class	IP40
Electrical protection class	III
Corrosion resistance class CRC ¹⁾	2

1) Corrosion resistance class 2 according to Festo standard 940 070
Components subject to moderate corrosion stress. Externally visible parts with primarily decorative surface requirements which are in direct contact with a normal industrial environment or media such as coolants or lubricating agents.

Pressure sensors SDE5

Technical data

Dimensions

Download CAD data → www.festo.com

SDE5-...-M8, plug version

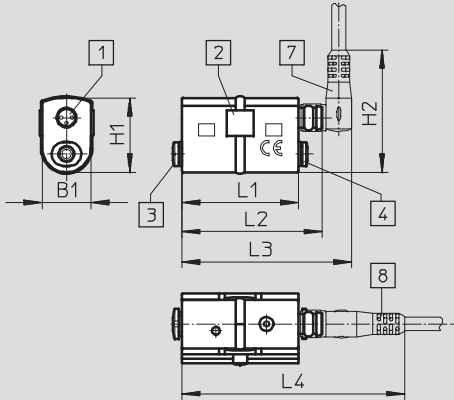

SDE5 with wall bracket

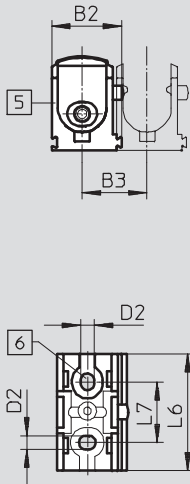

SDE5-...-K, cable version

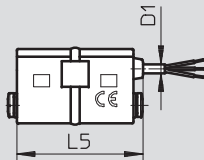

- 1 Plug M8x1, 3-pin or cable, 3-wire, 2.5 m long
- 2 LED display, visible from all sides
- 3 Pneumatic connection 1
- 4 Pneumatic connection 2 or blanking plug with SDE5-...E
- 5 Holder for wall mounting (included in scope of delivery)
- 6 2x through-hole for mounting screw
- 7 Connecting cable NEBU-M8W3 with angled plug socket
- 8 Connecting cable NEBU-M8G3 with straight plug socket

Type	B1	B2	B3	D1	D2	H1	H2	L1	L2	L3	L4	L5	L6	L7
SDE5-...-M8	16	23	21.4	-	4.5	24.5	40.3	38.5	45.5	56	73.5	-	38.5	20
SDE5-...-K				2.9			-		-		41.5			

Ordering data – Measured variable differential pressure

Pressure measuring range [bar]	Switching element function	Electrical output	Electrical connection	Pneumatic connection		Part No.	Type
				At one end	At both ends		
Freely programmable (switching/teach-in function, N/O contact, N/C contact)							
0 ... +10	Switchable	Switching output PNP	Plug, M8x1, 3-pin	-	QS-6	567460	SDE5-D10Z-FP-Q6-P-M8
Threshold value with fixed hysteresis, 1 teach-in pressure							
0 ... +10	N/O contact	Switching output PNP	Plug, M8x1, 3-pin	-	QS-6	567462	SDE5-D10Z-O-Q6-P-M8

Pressure sensors SDE5

Technical data

Ordering data – Measured variable relative pressure										
Pressure measuring range [bar]	Switching element function	Electrical output	Electrical connection	Pneumatic connection		Part No.	Type			
				At one end	At both ends					
Freely programmable (switching/teach-in function, N/O contact, N/C contact)										
0 ... -1	Switchable	Switching output PNP	Plug, M8x1, 3-pin	-	QS-6	542887	SDE5-V1-FP-Q6-P-M8			
0 ... +10	Switchable	Switching output PNP	Plug, M8x1, 3-pin	QS-4	-	542900	SDE5-D10-FP-Q4E-P-M8			
				QS-6	-	542897	SDE5-D10-FP-Q6E-P-M8			
				QS-1/4	-	567467	SDE5-D10-FP-T14E-P-M8			
				-	QS-6	542898	SDE5-D10-FP-Q6-P-M8			
			Cable, 3-wire	QS-4	-	542901	SDE5-D10-FP-Q4E-P-K			
				-	QS-6	542899	SDE5-D10-FP-Q6-P-K			
Threshold value with fixed hysteresis, 1 teach-in pressure										
0 ... -1	N/O contact	Switching output PNP	Plug, M8x1, 3-pin	QS-4	-	527460	SDE5-V1-O-Q4E-P-M8			
				QS-6	-	527461	SDE5-V1-O-Q6E-P-M8			
				-	QS-4	527457	SDE5-V1-O-Q4-P-M8			
				-	QS-6	527458	SDE5-V1-O-Q6-P-M8			
0 ... +2	N/O contact	Switching output PNP	Cable, 3-wire	QS-6	-	542888	SDE5-D2-O-Q6E-P-K			
0 ... +10	N/O contact	Switching output PNP	Plug, M8x1, 3-pin	QS-4	-	527466	SDE5-D10-O-Q4E-P-M8			
				QS-6	-	527467	SDE5-D10-O-Q6E-P-M8			
				QS-1/4	-	567468	SDE5-D10-O-T14E-P-M8			
				-	QS-4	527463	SDE5-D10-O-Q4-P-M8			
						-	QS-6	527464	SDE5-D10-O-Q6-P-M8	
					Cable, 3-wire	QS-6	-	542890	SDE5-D10-O-Q6E-P-K	
				Switching output NPN	Plug, M8x1, 3-pin	-	QS-6	567473	SDE5-D10-O-Q6-N-M8	
					Cable, 3-wire	-	QS-6	567469	SDE5-D10-O-Q6-N-K	
	N/C contact	Switching output PNP	Plug, M8x1, 3-pin	QS-4	-	542889	SDE5-D10-C-Q4E-P-M8			
				QS-6	-	542894	SDE5-D10-C-Q6E-P-M8			
						Cable, 3-wire	QS-6	-	542895	SDE5-D10-C-Q6E-P-K
Threshold value with fixed hysteresis, 2 teach-in pressures with mean value calculation										
0 ... -1	N/O contact	Switching output PNP	Plug, M8x1, 3-pin	-	QS-6	542886	SDE5-V1-O1-Q6-P-M8			
Threshold value with variable hysteresis, 2 teach-in pressures										
0 ... +10	N/O contact	Switching output PNP	Plug, M8x1, 3-pin	QS-6	-	542891	SDE5-D10-O2-Q6E-P-M8			
				-	QS-6	542892	SDE5-D10-O2-Q6-P-M8			
Window comparator with fixed hysteresis, 2 teach-in pressures										
0 ... +10	N/O contact	Switching output PNP	Cable, 3-wire	QS-6	-	542893	SDE5-D10-O3-Q6E-P-K			
	N/C contact	Switching output PNP	Cable, 3-wire	QS-6	-	542896	SDE5-D10-C3-Q6E-P-K			
Analogue output (no binary switching function)										
0 ... -1	-	Analogue output 0 ... 10 V	Plug, M8x1, 3-pin	QS-6	-	567463	SDE5-V1-NF-Q6E-V-M8			
				-	QS-6	567464	SDE5-V1-NF-Q6-V-M8			
					Cable, 3-wire	QS-6	-	567470	SDE5-V1-NF-Q6E-V-K	
0 ... +10	-	Analogue output 0 ... 10 V	Plug, M8x1, 3-pin	QS-6	-	567465	SDE5-D10-NF-Q6E-V-M8			
				-	QS-6	567466	SDE5-D10-NF-Q6-V-M8			
					Cable, 3-wire	QS-6	-	567471	SDE5-D10-NF-Q6E-V-K	
						-	QS-6	567472	SDE5-D10-NF-Q6-V-K	

Pressure sensors SDE5

Ordering data – Modular products

Ordering table				
Size	5	Condi- tions	Code	Enter code
M Module No.	529027			529027
Function	Pressure sensor		SDE5	SDE5
Pressure measuring range [bar]	0 ... -1		-V1	
	-1 ... 1		-B2	
	0 ... 2		-D2	
	0 ... 6		-D6	
	0 ... 10		-D10	
Pressure input	Relative pressure			
	Differential pressure		Z	
Output function	Freely programmable (switching/teach-in function, N/O contact, N/C contact)		-FP	
	Threshold value with fixed hysteresis, 1 teach-in point, N/O contact		-O	
	Threshold value with fixed hysteresis, 1 teach-in point, N/C contact		-C	
	Threshold value with fixed hysteresis, 2 teach-in points, N/O contact		-O1	
	Threshold value with fixed hysteresis, 2 teach-in points, N/C contact		-C1	
	Threshold value with variable hysteresis, N/O contact		-O2	
	Threshold value with variable hysteresis, N/C contact		-C2	
	Window comparator with fixed hysteresis, N/O contact		-O3	
	Window comparator with fixed hysteresis, N/C contact		-C3	
	No binary switching function (analogue output)		-NF	
Pneumatic connection	Push-in connector 4 mm, at both ends		-Q4	
	Push-in connector 6 mm, at both ends		-Q6	
	Push-in connector $\frac{5}{32}$ ", at both ends		-T532	
	Push-in connector $\frac{1}{4}$ ", at both ends		-T14	
	Push-in connector 4 mm, at one end	<input type="text" value="4"/>	-Q4E	
	Push-in connector 6 mm, at one end	<input type="text" value="4"/>	-Q6E	
	Push-in connector $\frac{5}{32}$ ", at one end	<input type="text" value="4"/>	-T532E	
	Push-in connector $\frac{1}{4}$ ", at one end	<input type="text" value="4"/>	-T14E	
Electrical output	1 switching output PNP	<input type="text" value="5"/>	-P	
	1 switching output NPN	<input type="text" value="5"/>	-N	
	1 analogue output 0 ... 10 V	<input type="text" value="6"/>	-V	
Electrical connection	Cable, 2.5 m		-K	
	Plug M8, 3-pin		-M8	
O Electrical accessories	Connecting cable, straight socket, 2.5 m	<input type="text" value="1"/>	-G	
	Connecting cable, angled socket, 2.5 m	<input type="text" value="1"/>	-W	
	Connecting cable, straight socket, 5 m	<input type="text" value="1"/>	-G5	
	Connecting cable, angled socket, 5 m	<input type="text" value="1"/>	-W5	
X teach-in point permanently set in bar	-0.85 ... 10 ¹	<input type="text" value="2"/>	-...X	
X teach-in point negative	Negative range	<input type="text" value="7"/>	V	
Y teach-in point permanently set in bar	-0.85 ... 10 ¹	<input type="text" value="2"/> <input type="text" value="3"/>	-...Y	
Y teach-in point negative	Negative range	<input type="text" value="8"/>	V	

1 **G, W, G5, W5** Only in combination with M8

2 **X, Y** Not in combination with FP, O1, C1, NF
Must have a value if O2, C2, O3, C3
and X or Y was selected

Only one decimal place permissible in combination with D10

3 **Y** Not in combination with O, C

4 **Q4E, Q6E, T532E, T14E**

Not in combination with pressure input Z

5 **P, N** Not in combination with output function NF

6 **V** Only in combination with output function NF

7 **V** Only in combination with B2 and X teach-in point in the negative range,
but then mandatory entry

8 **V** Only in combination with B2 and Y teach-in point in the negative range,
but then mandatory entry

1) Permitted value range. The value for the permanently set teach-in point must always be within the chosen pressure measuring range V1, B2, D2, D6, D10.

Note on V1: Enter the teach-in pressure without a sign.

Note on B2: Enter the teach-in pressure for vacuum without a sign, but with a suffixed "V", see or .



Transfer order code

- - - - - - - - - - - -

Pressure sensors SDE5

Accessories

FESTO

Ordering data – Connecting cable NEBU-M8					Technical data → Internet: nebu	
	Electrical connection	Number of wires	Cable length [m]	Order code ¹⁾	Part No.	Type
	M8x1, straight plug socket	3	2.5	G	541333	NEBU-M8G3-K-2.5-LE3
		3	5	G5	541334	NEBU-M8G3-K-5-LE3
	M8x1, angled plug socket	3	2.5	W	541338	NEBU-M8W3-K-2.5-LE3
		3	5	W5	541341	NEBU-M8W3-K-5-LE3

1) When ordering using the modular system → 10