

## Vacuum efficiency valves ISV

**FESTO**



# Vacuum efficiency valves ISV

Features

## Areas of application

- For parallel arrangement of several suction cups
  - To prevent dissipation of the vacuum if one or several suction cups do not make full contact
- Gripping of randomly placed products
- Saves compressed air and energy
  - Retention is only successful if 100% contact is achieved
- Maintains vacuum

## Function diagram

These valves are suitable for applications requiring several vacuum suction cups and for the maintenance of vacuum in the event that one suction cup should fail to make contact.

- 1 Vacuum generator
- 2 Distributor
- 3 Vacuum efficiency valve
- 4 Suction cup

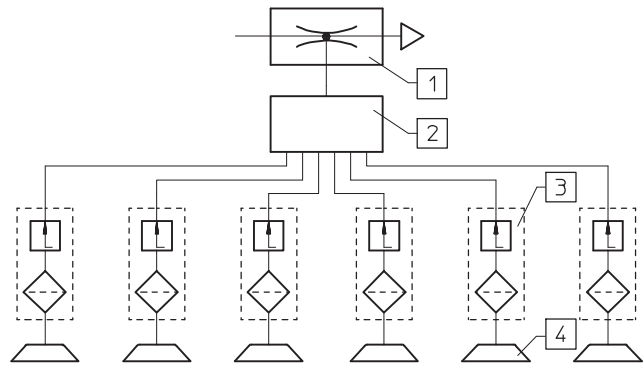

## Vacuum efficiency valve function

The ISV valve is fitted between the vacuum generator and the suction cup.

If, during vacuum generation, a suction cup is uncovered, or only partly covered, the ISV automatically stops the influx of air.

When the suction cup fits tightly against the surface, a vacuum is regenerated. Removal of the object from the suction cup causes the ISV valve to close immediately.

1. When the suction cup is open to atmosphere, the float is drawn back against the housing. In this position, flow is only possible through the small hole in the end of the float.
2. When an object is in contact with the suction cup, flow is reduced and the spring forces the float forward. The seal is thus broken and full vacuum is generated within the suction cup.

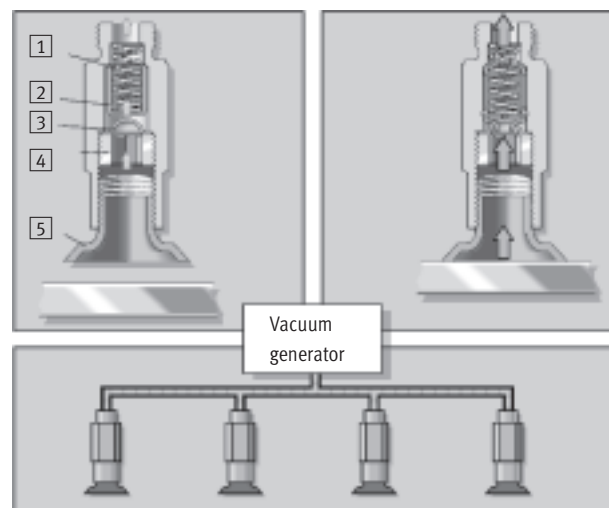

- 1 Spring
- 2 Float
- 3 Filter
- 4 Retaining screw
- 5 Suction cup

# Vacuum efficiency valves ISV

Technical data

FESTO

Function

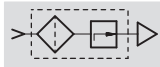

- - Temperature range  
-10 ... +60 °C

- - Operating pressure  
-0.95 ... 0 bar

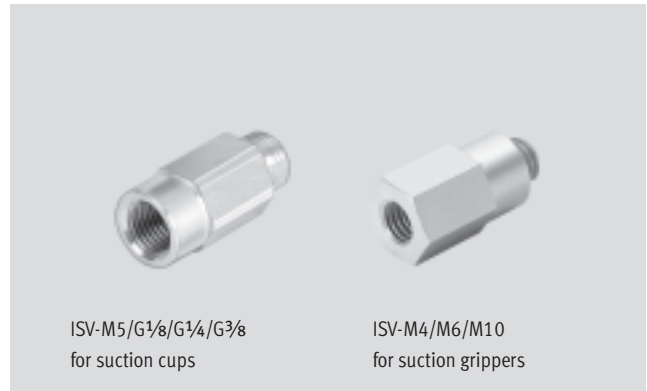

ISV-M5/G $\frac{1}{8}$ /G $\frac{1}{4}$ /G $\frac{3}{8}$   
for suction cups

ISV-M4/M6/M10  
for suction grippers

General technical data							
Size	For suction cups				For suction grippers		
	M5	G $\frac{1}{8}$	G $\frac{1}{4}$	G $\frac{3}{8}$	M4	M6	M10
Operating medium	Atmospheric air						
Mounting position	Any						
Type of mounting	Screw-in						
Pneumatic connection	M5	G $\frac{1}{8}$	G $\frac{1}{4}$	G $\frac{3}{8}$	M4	M6	M10
Operating pressure [bar]	-0.95 ... 0						
Ejector pulse possibility [bar]	≤ 8						
Required suction rate at -0.5 bar [l/min]	1	2	1.6	1.5	1	2	2

Ambient conditions							
Size	For suction cups				For suction grippers		
	M5	G $\frac{1}{8}$	G $\frac{1}{4}$	G $\frac{3}{8}$	M4	M6	M10
Ambient temperature [°C]	-10 ... +60						
Corrosion resistance CRC <sup>1)</sup>	2						

1) Corrosion resistance class 2 according to Festo standard 940 070

Components requiring moderate corrosion resistance. Externally visible parts with primarily decorative surface requirements which are in direct contact with a surrounding industrial atmosphere or media such as cooling or lubricating agents.

Weights [g]							
Size	For suction cups				For suction grippers		
	M5	G $\frac{1}{8}$	G $\frac{1}{4}$	G $\frac{3}{8}$	M4	M6	M10
ISV-...	4	9	16	33	1.5	14	18

Materials							
Size	For suction cups				For suction grippers		
	M5	G $\frac{1}{8}$	G $\frac{1}{4}$	G $\frac{3}{8}$	M4	M6	M10
Housing	Wrought aluminium alloy				Wrought aluminium alloy		
Filter	Sintered bronze <sup>1)</sup>	Wrought aluminium alloy, stainless steel mesh			Sintered bronze		
Spring	-	High-alloy stainless steel			-	High-alloy stainless steel	
Hollow bolt	-	Wrought aluminium alloy			-		
Float	-	Polyacetate			-	Polyacetate	

1) Filter ISV-M5-CT made of sintered steel

# Vacuum efficiency valves ISV

Technical data

FESTO

## Evacuation time $t$ as a function of the volume to be evacuated $V$ with various ejectors

ISV-...-M5

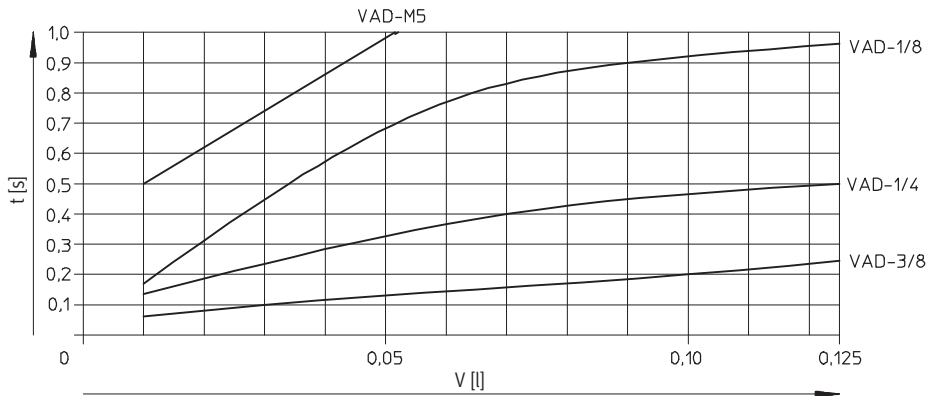

ISV-...-1/8/ISV-...-1/4

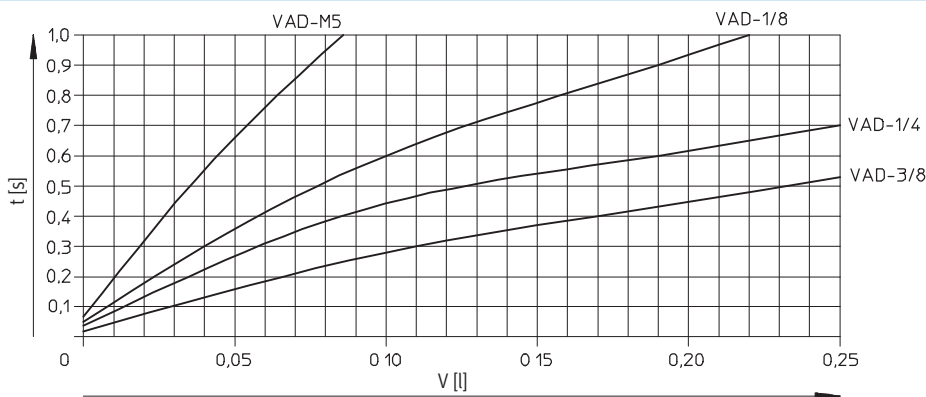

ISV-...-3/8

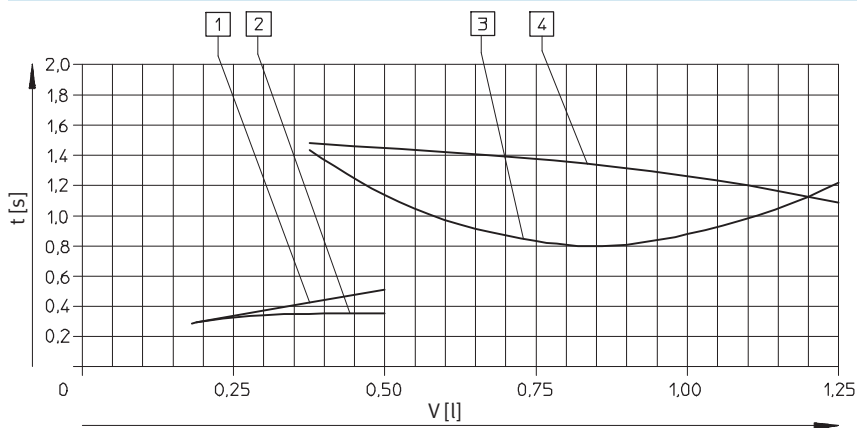

- 1 VAD-...-3/8 with flat suction cup VAS-125-...
- 2 VAD-ME-...-3/8 with flat suction cup VASB-125-...
- 3 VAD-...-3/8 with bellows suction cup VASB-125-...
- 4 VAD-ME-...-3/8 with bellows suction cup VASB-125-...

-  - Note

Evacuation time is the time required to attain 90% maximum possible vacuum.

# Vacuum efficiency valves ISV

Technical data

FESTO

## Conditions for operation of the vacuum efficiency valve ISV

- The number of vacuum suction cups that can be attached depends upon the suction capacity of the ejector.
- A minimum switching flow rate is required to ensure the function of each ISV vacuum efficiency valve connected in parallel to an ejector.
- The number of cups which can be reliably operated can be estimated on the basis of the ratio of ejector suction power and the minimum switching flow rate of the ISV vacuum efficiency valve.

## Max. no. of sealed suction cups as a function of the vacuum generator used and the attainable vacuum level

Vacuum generator	Max. number of suction cups at P <sub>U</sub> [bar]											
	ISV-M5			ISV-1/8			ISV-1/4			ISV-3/8		
	-0.5	-0.6	-0.7	-0.5	-0.6	-0.7	-0.5	-0.6	-0.7	-0.5	-0.6	-0.7
VAD-M5	2	1	-	1	1	-	1	-	-	-	-	-
VAD-1/8	4	2	1	2	1	-	2	1	-	-	-	-
VAD-1/4	8	6	3	4	3	1	4	3	1	-	-	-
VAD-3/8	8	8	7	7	6	3	7	6	3	-	2	1
VADM/VADMI-45	2	1	-	1	1	-	1	-	-	-	-	-
VADM/VADMI-70	4	2	1	2	1	-	2	1	-	-	-	-
VADM/VADMI-95	8	6	3	4	3	1	4	2	1	-	-	-
VADM/VADMI-140	8	8	7	7	6	3	7	6	3	3	2	1
VADM/VADMI-200	16	16	14	14	12	6	14	12	6	6	4	2
VADM/VADMI-300	32	32	28	28	24	12	28	14	12	12	8	4

## Dimensions

ISV-...

ISV-M4/M6/M10

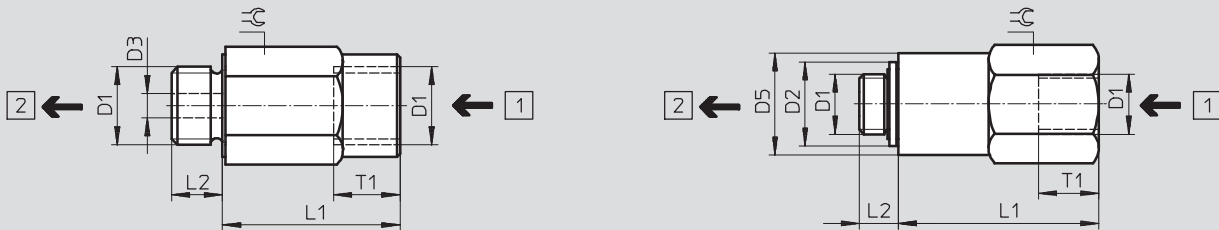

- 1 Suction side
- 2 Tubing side

Type	D1	D2 Ø	D3 Ø	D5 Ø	L1	L2	T1	⊘
ISV-M5	M5	-	2	-	10	5	5.5	8
ISV-1/8	G1/8	-	4	-	29.5	6.5	11	13
ISV-1/4	G1/4	-	4	-	30	8	11	17
ISV-3/8	G3/8	-	4	-	30	9	13	22
ISV-M4	M4	7.6	-	7	10.7	3.8	5	7
ISV-M6	M6	8.4	-	14	28.3	5	5	14
ISV-M10	M10	14	-	17	32	6.5	10	17

## Ordering data

Pneumatic connection	For suction cups		Pneumatic connection	For suction grippers	
	Part No.	Type		Part No.	Type
M5	151217	ISV-M5	M4	545996	ISV-M4
G1/8	33969	ISV-1/8	M6	545997	ISV-M6
G1/4	33970	ISV-1/4	M10	545998	ISV-M10
G3/8	33971	ISV-3/8			