

Passive guide axes ELFR, without drive



Passive guide axes ELFR, without drive

Key features

At a glance

- Driveless linear guide units with guide and freely movable slide
- Passive guide axes are designed to increase force and torque in multi-axis applications
- Higher torsional resistance
- Reduced vibrations with dynamic loads
- Drive axes and passive guide axes can be arranged adjacent to or above one another
- Plain-bearing guide
 - For small loads
 - Restricted operating behaviour with torque load
 - Guide backlash = 0.05 mm (on delivery)
- Recirculating ball bearing guide
 - For medium loads
 - Very good operating behaviour with torque load
 - Backlash-free guide (preloaded guide elements)

Associated drive axis

Toothed belt axis ELGR



- For size 35, 45, 55
- Load capacity up to max. 300 N or 124 Nm
- Max. feed force 350 N

System product for handling and assembly technology

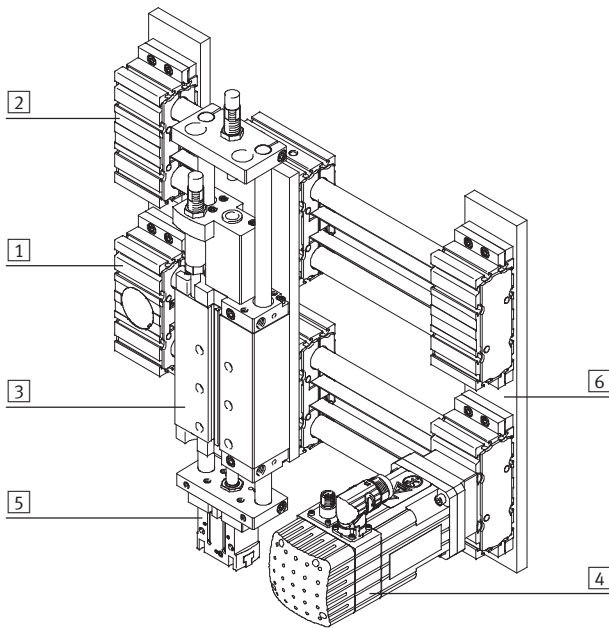

System components and accessories

	Brief description	→ Page/Internet
1	Axes	axis
2	Guide axes	guide axis
3	Drives	drive
4	Motors	motor
5	Grippers	gripper
6	Adapters	adapter kit

Passive guide axes ELFR, without drive

Type codes

		ELFR	-		-	45	-	500	-	30H	-	L	-		+	2SA			4NM	2MA
Type																				
ELFR	Passive guide axis																			
Guide																				
-	Recirculating ball bearing guide																			
GF	Plain-bearing guide																			
Size																				
Stroke [mm]																				
Stroke reserve																				
Slide																				
-	Standard slide																			
L	Long slide																			
Additional slide																				
-	No additional slide																			
ZR	1 slide on right																			
ZL	1 slide on left																			
ZB	1 slide on right, 1 slide on left																			
Proximity sensor																				
...SA	Proximity sensor (SIES), inductive, T-slot, PNP, N/O contact, 7.5 m cable																			
...SB	Proximity sensor (SIES), inductive, T-slot, PNP, N/C contact, 7.5 m cable																			
Cover																				
...NC	For mounting slot																			
Slot nut																				
...NM	For mounting slot																			
Profile mounting																				
...MA	Profile mounting																			

Passive guide axes ELFR, without drive

Peripherals overview

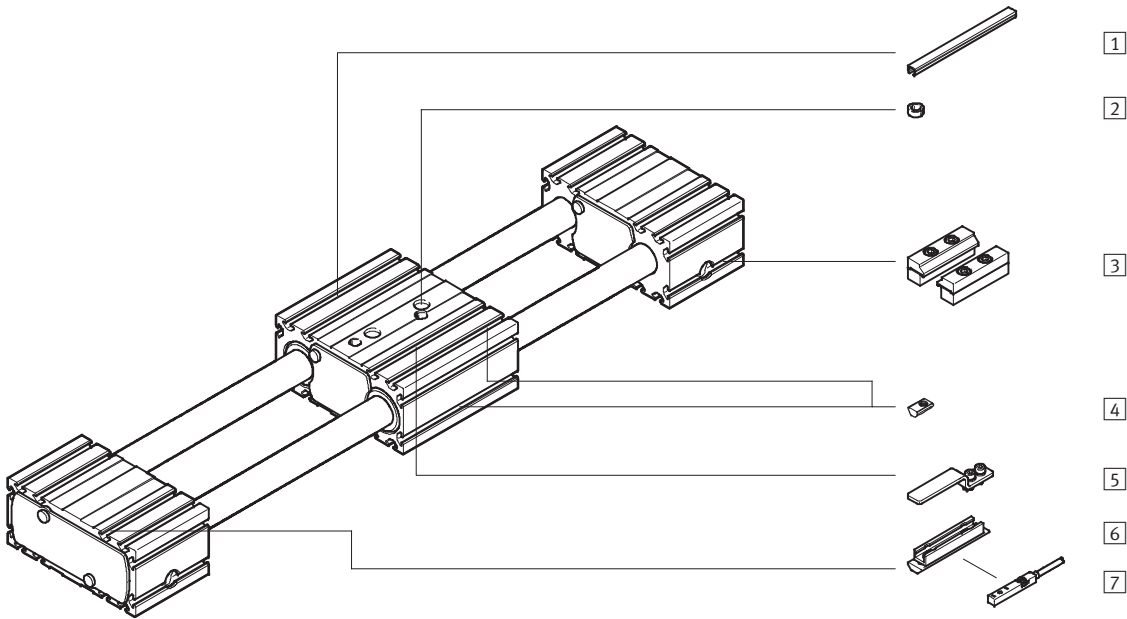





Variants and accessories		
Type	Brief description	→ Page/Internet
1 Slot cover NC	<ul style="list-style-type: none"> For protecting against ingress of dirt 	13
2 Centring sleeve ZBH	<ul style="list-style-type: none"> For centring loads and attachments on the slide 6 centring sleeves included in the scope of delivery of the axis 	13
3 Profile mounting MA	For mounting the axis on the bearing cap	12
4 Slot nut NM	For mounting attachments	13
5 Switch lug SA, SB	For sensing the slide position	12
6 Sensor bracket SA, SB	Adapter for mounting the inductive proximity sensors on the axis	12
7 Proximity sensor, T-slot SA, SB	<ul style="list-style-type: none"> Inductive proximity sensor, for T-slot The scope of delivery with the order code SA, SB includes 1 switch lug and 1 sensor bracket 	13
- Connecting cable NEBU	For proximity sensors (order code SA and SB)	13

Passive guide axes ELFR, without drive

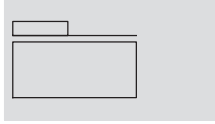
Technical data

Function



-  - Size
35 ... 55
-  - Stroke length
50 ... 1,500 mm
-  - www.festo.com

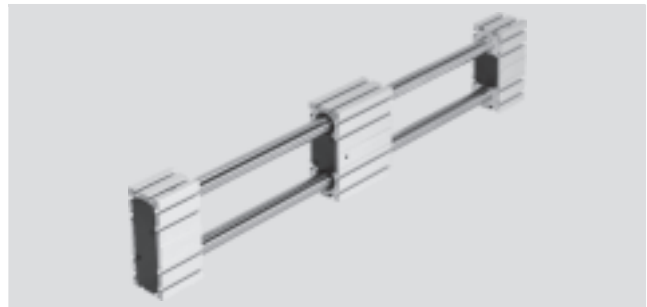

General technical data				
Size		35	45	55
Design		Passive guide axis		
Guide		Recirculating ball bearing guide		
		Plain-bearing guide		
Mounting position		Any		
Working stroke	[mm]	50 ... 800	50 ... 1,000	50 ... 1,500
Max. no-load resistance to shifting	[N]	3	6	10
Max. speed				
Recirculating ball bearing guide	[m/s]	3		
Plain-bearing guide	[m/s]	1		
Max. acceleration	[m/s ²]	50		

Operating and environmental conditions		
Ambient temperature		
Recirculating ball bearing guide	[°C]	-10 ... +50
Plain-bearing guide	[°C]	0 ... +40
Protection class		IP20

Weight [kg]				
Size		35	45	55
Recirculating ball bearing guide				
Basic weight with 0 mm stroke ¹⁾				
Standard slide		1.2	2.7	4.6
Long slide		1.6	3.8	6.5
Additional weight per 1,000 mm stroke		2.4	5.0	7.7
Moving load		0.4	0.9	1.7
Slide				
Standard slide		0.4	0.9	1.7
Long slide		0.7	1.5	2.8
Additional slide		0.4	0.9	1.7

1) Incl. slide

Passive guide axes ELFR, without drive

Technical data

Weight [kg]			
Size	35	45	55
Plain-bearing guide			
Basic weight with 0 mm stroke ¹⁾			
Standard slide	1.1	2.5	4.2
Long slide	1.6	3.7	6.4
Additional weight per 1,000 mm stroke	2.3	5.0	7.7
Moving load	0.3	0.7	1.3
Slide			
Standard slide	0.3	0.7	1.3
Long slide	0.6	1.5	2.6
Additional slide	0.3	0.7	1.3

1) Incl. slide

Materials

Sectional view

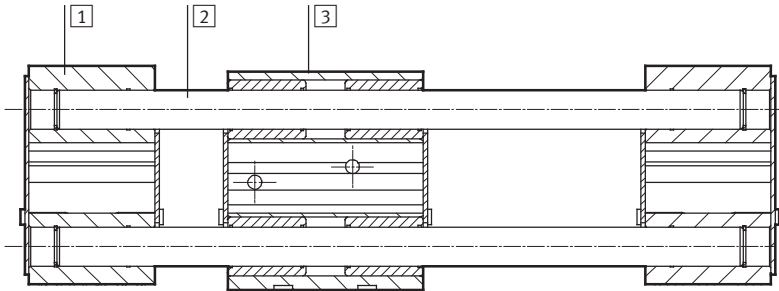

Axis	
1	Bearing cap, profile Anodised wrought aluminium alloy
2	Guide rods Steel
3	Slide, profile Anodised wrought aluminium alloy
Note on materials RoHS-compliant	
Contains PWIS (paint wetting impairment substances)	

Passive guide axes ELFR, without drive

Technical data

Characteristic load values

The indicated forces and torques refer to the centre of the guide. The point of application of force is the point where the centre of the guide and the longitudinal centre of the slide intersect. These values must not be exceeded during dynamic operation. Special attention must be paid to the cushioning phase.

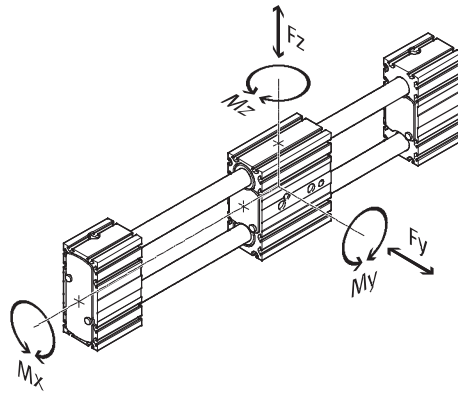

If the axis is subjected to more than two of the indicated forces and torques simultaneously, the following equation must be satisfied in addition to the indicated maximum loads:

Calculating the load comparison factor:

$$f_v = \frac{|F_{y,dyn}|}{F_{y,max.}} + \frac{|F_{z,dyn}|}{F_{z,max.}} + \frac{|M_{x,dyn}|}{M_{x,max.}} + \frac{|M_{y,dyn}|}{M_{y,max.}} + \frac{|M_{z,dyn}|}{M_{z,max.}} \leq 1$$

Permissible forces and torques for a service life of 5,000 km							
Guide		Plain-bearing guide			Recirculating ball bearing guide		
Size		35	45	55	35	45	55
$F_{y,max.}, F_{z,max.}$	[N]	50	100	300	50	100	300
Standard slide							
$M_{x,max.}$	[Nm]	1	2.5	5	2.5	5	15
$M_{y,max.}$	[Nm]	4	8	16	8	16	48
$M_{z,max.}$	[Nm]	4	8	16	8	16	48
Long slide							
$M_{x,max.}$	[Nm]	1	2.5	5	2.5	5	15
$M_{y,max.}$	[Nm]	10	20	40	20	40	124
$M_{z,max.}$	[Nm]	10	20	40	20	40	124

Service life

The service life of the guide depends on the load. To provide a rough indication of the service life of the guide, the

graph below plots the load comparison factor f_v against the service life.

These values are only theoretical. Consultation with your local contact person at Festo is mandatory for load

comparison factors f_v greater than 1.5.

Load comparison factor f_v as a function of service life

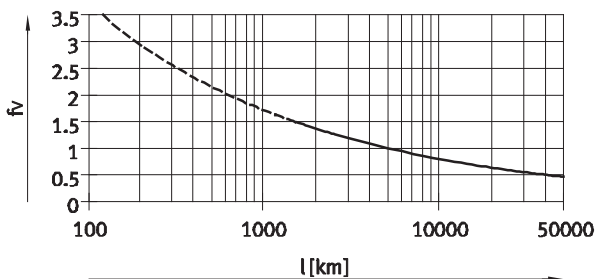

Example:

A user wants to move an X kg load. Using the above formula gives a value of 1.5 for the load comparison factor f_v . According to the graph, the guide would have a service life of

approx. 1,500 km. Reducing the acceleration reduces the M_z and M_y values. A load comparison factor of 1 now gives a service life of 5,000 km.

Note
PositioningDrives
sizing software
www.festo.com

Passive guide axes ELFR, without drive

Technical data

Stroke reserve

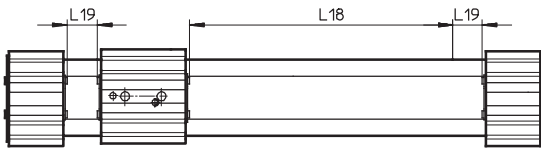

L18 = Nominal stroke
L19 = Stroke reserve

- The stroke reserve is a safety distance that can be available on both sides of the axis in addition to the nominal stroke
- The sum of the nominal stroke and 2x stroke reserve must not exceed the maximum working stroke
- The stroke reserve length can be freely selected
- The stroke reserve is defined via the “stroke reserve” attribute in the modular product system

Example:

Type ELFR-45-500-20H-...
Nominal stroke = 500 mm
2x stroke reserve = 40 mm

Working stroke = 540 mm
(540 mm = 500 mm + 2x 20 mm)

Working stroke reduction

With standard slide or long slide L with additional slide ZR/ZL/ZB

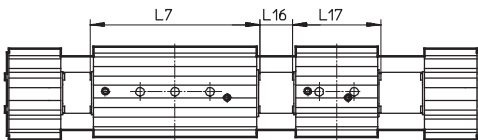

L7 = Slide length
L16 = Distance between both slides
L17 = Additional slide length

- With a toothed belt axis with additional slide, the working stroke is reduced by the length of the additional slide and the distance between both slides
- If the long slide L variant is ordered, the additional slide is not extended

Example:

Type ELFR-35-500-...-ZR
Working stroke = 500 mm
L16 = 10 mm
L7, L17 = 76 mm

Working stroke with additional slide = 414 mm
(500 mm – 10 mm – 76 mm)

Dimensions – Additional slide

Size	35	45	55
Length L17 [mm]	76	96	116
Distance between the slides L16 [mm]	≥ 0		

2nd moment of area

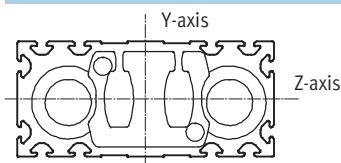

Size	35	45	55
ly [mm ⁴]	3.77x10 ³	1.57x10 ⁴	3.83x10 ⁴
lz [mm ⁴]	1.89x10 ⁵	8.08x10 ⁵	1.85x10 ⁶

Recommended deflection limits

Adherence to a maximum deflection of 0.5 mm is recommended so as not to impair the functional performance of the axes. Greater deformation can result in increased friction, greater wear and reduced service life.

Passive guide axes ELFR, without drive

Technical data

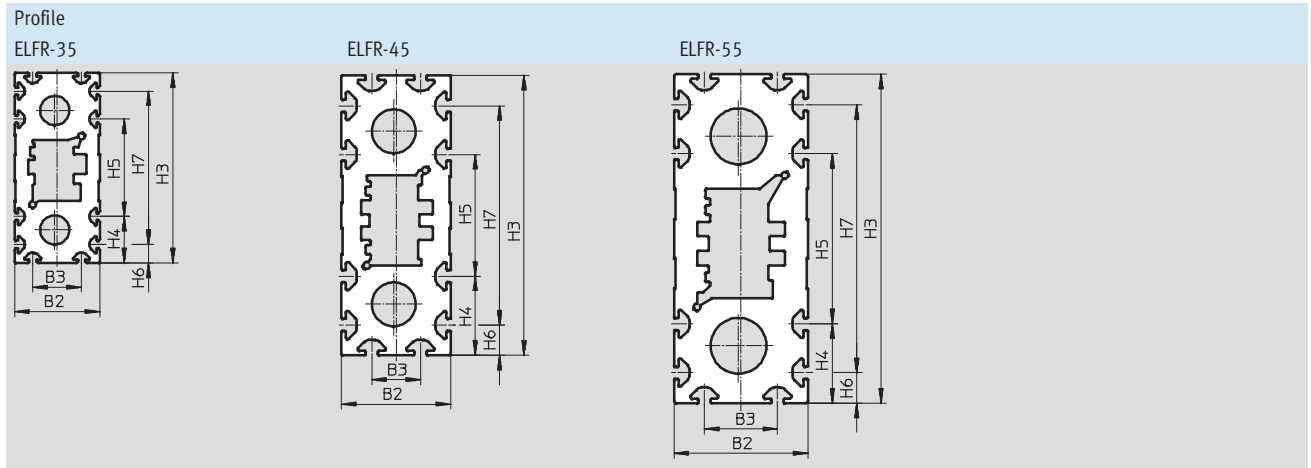
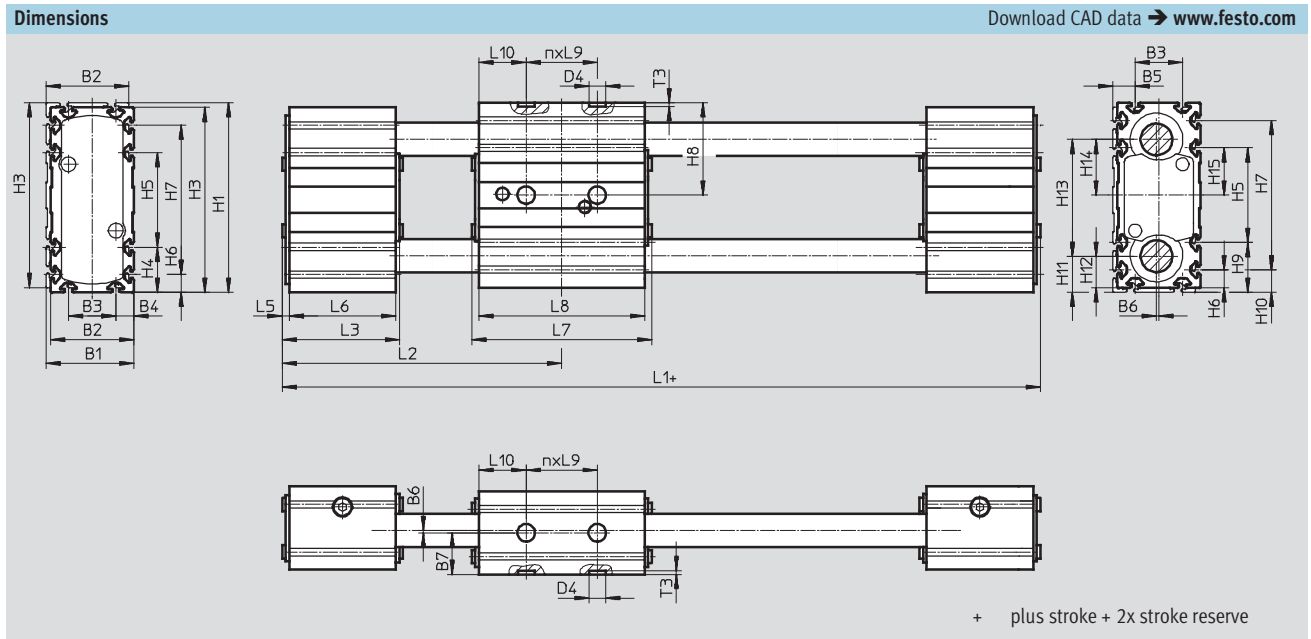

Size	B1	B2	B3	B4	B5	B6	B7	D4 ∅ H7	H1	H3	H4	H5	H6	H7	H8	H9
ELFR-35	37	35	20	7.5	9.5	1	17.5	7	80	78	19	40	7.5	63	39	21
ELFR-35-L																
ELFR-45	47	45	20	12.5	14.5	1	22.5	7	117	115	32.5	50	12.5	90	57.5	34.5
ELFR-45-L																
ELFR-55	57	55	30	12.5	14.5	1	27.5	7	137	135	32.5	70	12.5	110	67.5	34.5
ELFR-55-L																

Size	H10	H11	H12	H13	H14	H15	L1	L2	L3	L5	L6	L7	L8	L9	L10	n	T3 +0.1
ELFR-35	9.5	15.5	13.5	49	23.5	20	178	89	51	3	45	76	70	30	20	1	1.6
ELFR-35-L							248	124				146	140		40	2	
ELFR-45	14.5	23	21	71	34.5	25	219	108	60	3	54	96	90	40	25	1	1.6
ELFR-45-L							309	153				186	180		50	2	
ELFR-55	14.5	25.5	23.5	86	42	35	243	120	62	3	56	116	110	40	35	1	1.6
ELFR-55-L							353	175				226	220		70	2	

Passive guide axes ELFR, without drive

Ordering data – Modular products

Order code

Mandatory data

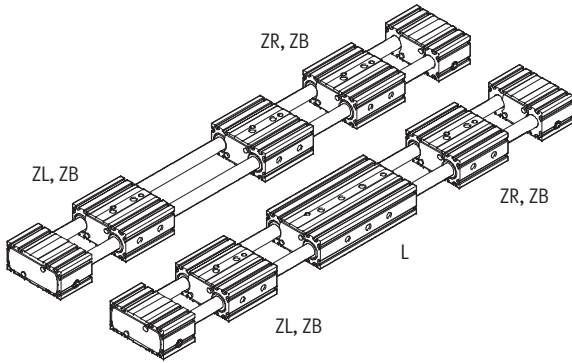
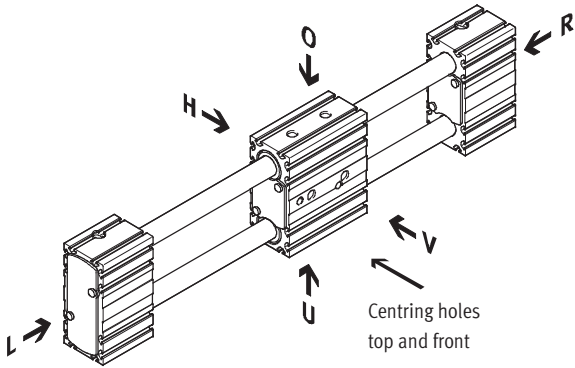

- O top L left
- U underneath V front
- R right H rear

Accessories

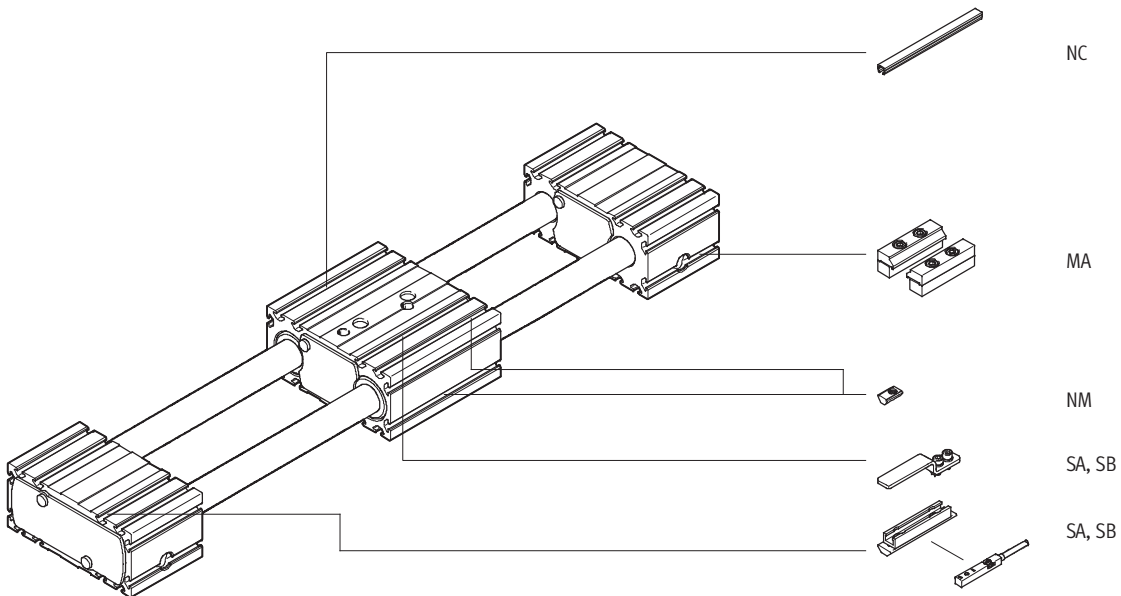

Passive guide axes ELFR, without drive

Ordering data – Modular products

Ordering table		35	45	55	Condi- tions	Code	Enter code
Size		35	45	55			
M	Module No.	571435	571436	571437			
	Design	Passive guide axis				ELFR	ELFR
O	Guide	Recirculating ball bearing guide					
		Plain-bearing guide				-GF	
M	Size	35	45	55		-...	-...
	Stroke length [mm]	1 ... 800	1 ... 1,000	1 ... 1,500		-...	-...
	Stroke reserve [mm]	0 ... 999 (0 = no stroke reserve)			1	-...H	
O	Slide design	Standard slide					
		Long slide				-L	
	Additional slide	No additional slide					
		1 slide on right			2	-ZR	
		1 slide on left			2	-ZL	
		1 slide on right, 1 slide on left			2	-ZB	
	Accessories	Accessories enclosed separately				+	+
	Proximity sensor (SIES), inductive, T-slot, PNP, incl. switch lug and sensor bracket	N/O contact, 7.5 m cable	1 ... 6			...SA	
		N/C contact, 7.5 m cable	1 ... 6			...SB	
	Mounting slot cover	-	1 ... 50 (1 = 2 units, 500 mm)			...NC	
	Slot nut for mounting slot	1 ... 99				...NM	
	Profile mounting	1 ... 2				...MA	

- 1** -... The sum of the nominal stroke and 2x stroke reserve must be at least 50 mm and must not exceed the maximum stroke length.
- 2** **ZR, ZL, ZB** Working stroke reduction → 8

Transfer order code

Passive guide axes ELFR, without drive

Accessories

Profile mounting MUE
(order code MA)

Material:
Anodised aluminium
RoHS-compliant

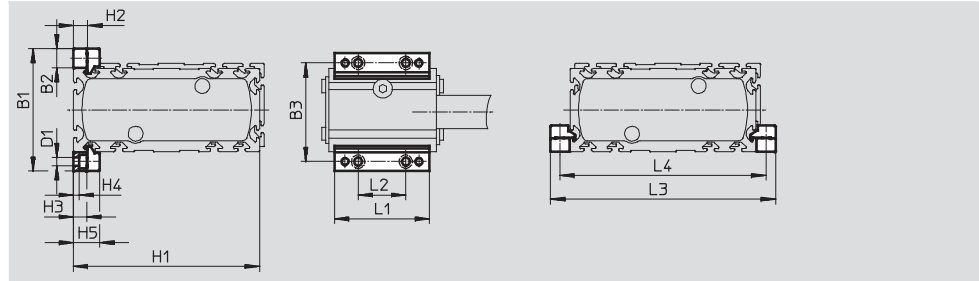

Dimensions and ordering data								
For size	B1	B2	B3	D1 ∅	H1	H2	H3	H4
35	51	8	43	3.4	78	6	5.5	2.3
45	69	12	57	5.5	115	10	9	3.2
55	79	12	67	5.5	135	10	9	3.2

For size	H5	L1	L2	L3	L4	Weight [g]	Part No.	Type
35	11	40	20	94	86	20	558042	MUE-50
45	17.5	52	40	139	127	32	562238	MUE-45
55	17.5	52	40	159	147	32	562238	MUE-45

Sensor bracket EAPM-...-SHS,
switch lug EAPM-...-SLS
(order code SA/SB)

Materials:
Switch lug: Galvanised steel
Sensor bracket: Anodised wrought
aluminium alloy
RoHS-compliant

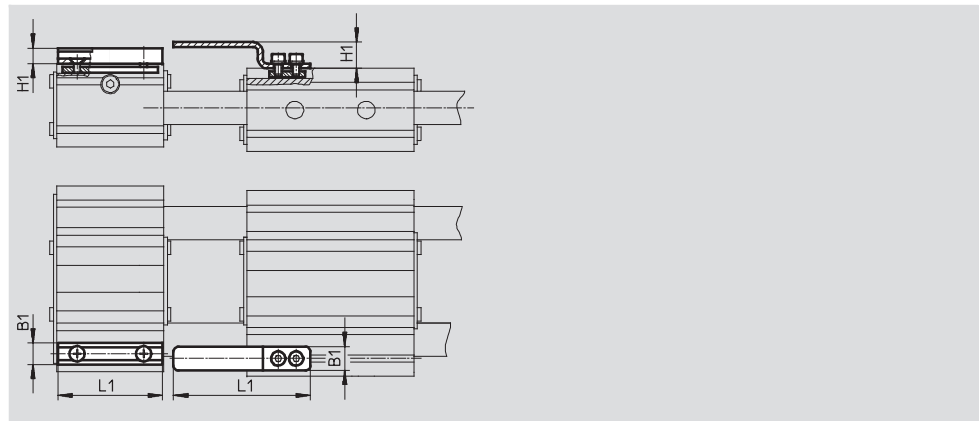



Dimensions and ordering data							
For size	B1	H1	L1	Weight [g]	Part No.	Type	
Sensor bracket							
35, 45, 55	9	6.5	44	20	567537	EAPM-L4-SHS	
Switch lug							
35, 45, 55	10	11	57.5	15	567538	EAPM-L4-SLS	

Passive guide axes ELFR, without drive

Accessories

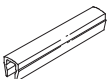

FESTO

Ordering data						
	For size	Comment	Order code	Part No.	Type	PU ¹⁾
Slot nut NST						
	35	For mounting slot	NM	558045	NST-3-M3	1
	45, 55			150914	NST-5-M5	
Centring sleeve ZBH²⁾						
	35, 45, 55	For slide	-	186717	ZBH-7	10
Slot cover ABP						
	45, 55	For mounting slot every 0.5 m	NC	151681	ABP-5	2

1) Packaging unit

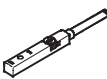
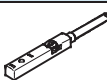
2) 6 centring sleeves included in the scope of delivery of the axis

Ordering data – Proximity sensors for T-slot, inductive							Technical data → Internet: sies	
	Type of mounting	Electrical connection	Switching output	Cable length [m]	Order code	Part No.	Type	
N/O contact								
	Insertable in the slot from above, flush with the cylinder profile	Cable, 3-wire	PNP	7.5	SA	551386	SIES-8M-PS-24V-K-7,5-OE	
		Plug M8x1, 3-pin		0.3	-	551387	SIES-8M-PS-24V-K-0,3-M8D	
		Cable, 3-wire	NPN	7.5	-	551396	SIES-8M-NS-24V-K-7,5-OE	
		Plug M8x1, 3-pin		0.3	-	551397	SIES-8M-NS-24V-K-0,3-M8D	
N/C contact								
	Insertable in the slot from above, flush with the cylinder profile	Cable, 3-wire	PNP	7.5	SB	551391	SIES-8M-PO-24V-K-7,5-OE	
		Plug M8x1, 3-pin		0.3	-	551392	SIES-8M-PO-24V-K-0,3-M8D	
		Cable, 3-wire	NPN	7.5	-	551401	SIES-8M-NO-24V-K-7,5-OE	
		Plug M8x1, 3-pin		0.3	-	551402	SIES-8M-NO-24V-K-0,3-M8D	

Ordering data – Connecting cables					Technical data → Internet: nebu	
	Electrical connection, left	Electrical connection, right	Cable length [m]	Part No.	Type	
	Straight socket, M8x1, 3-pin	Cable, open end, 3-wire	2.5	541333	NEBU-M8G3-K-2.5-LE3	
			5	541334	NEBU-M8G3-K-5-LE3	
	Angled socket, M8x1, 3-pin	Cable, open end, 3-wire	2.5	541338	NEBU-M8W3-K-2.5-LE3	
			5	541341	NEBU-M8W3-K-5-LE3	