

Rotary lifting modules EHMB, electric



Rotary lifting modules EHMB, electric

Key features

At a glance

The rotary lifting module EHMB combines rotary and linear movement in one compact unit. The rotary movement is transmitted to a hollow shaft via a toothed belt driven by an electric motor while the linear movement is generated either by means of

a pneumatic cylinder DNC or an electric cylinder DNCE. Both movements act on the output flange, which is compatible with the semi-rotary drive DRQD, so that numerous grippers can be used.

Cables and tubing can be easily

routed to the front end of the rotary lifting module through the large hollow shaft.

The movement range can also be sensed via proximity sensors at the rotary unit and the cylinder.

Advantages:

- Large hollow shaft
- Stable bearing arrangement
- Various motors and cylinders enable easy adaptation of the performance to the application

The technology in detail

- 1 Stop nut
- 2 Grooved-shaft guide
- 3 Through-hole for mounting
- 4 Mounting thread/holes
- 5 Output flange with centring and threaded holes for effective load. The interface corresponds to that of the pneumatic semi-rotary drive DRQD
- 6 Drive shaft for rotary movement
- 7 Cylinder retainer
- 8 Rod eye and connection bolt for linear movement

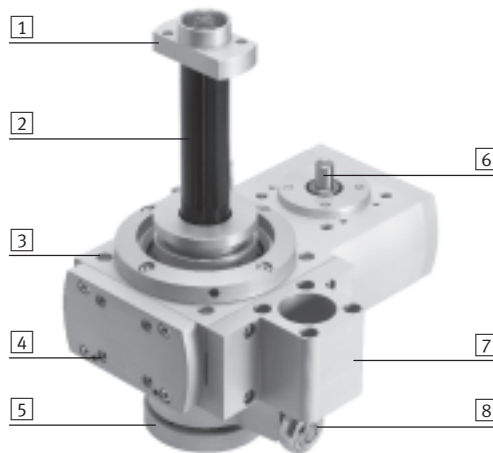

Flexible connection

Orientation:

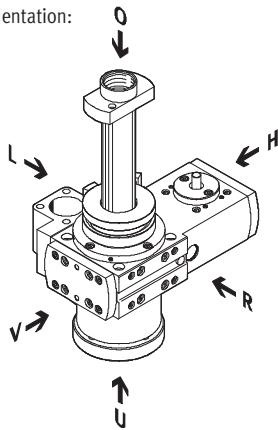

- O= top
- U= underneath
- R= right
- V= front
- L= left
- H= rear

- The rotary lifting module EHMB can be mounted on four sides:
 - On the right or left of the housing (L, R)
 - On the front cover (V)
 - Underneath the housing (U)
- The cylinder retainer can be mounted on three sides:
 - On the right or left of the housing (L, R)
 - On the front, after removing the front cover (V)
- The side where the cylinder retainer is mounted cannot be used for mounting the rotary lifting module.
- A pneumatic standard cylinder DNC or an electric cylinder DNCE can be attached to the cylinder retainer (these cylinders must be ordered separately).

 **Note**

Eccentric loads can destroy the bearing.
The front side (V) is only permissible for mounting with a symmetrical applied load.

Rotary lifting modules EHMB, electric

Key features

Complete system consisting of rotary lifting module, motor and axial kit

Rotary lifting module

→ 6

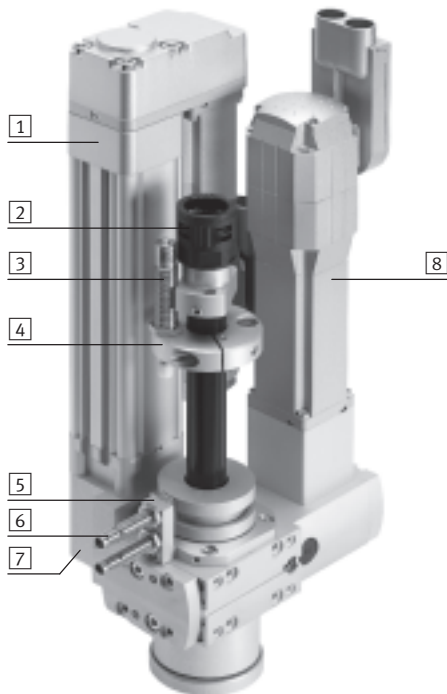

- 1) Electric cylinder DNCE or standard cylinder DNC¹⁾
- 2) Protective conduit fitting¹⁾
- 3) Shock absorber¹⁾
- 4) Shock absorber retainer¹⁾
- 5) Sensor retainer
- 6) Proximity sensor SIEN¹⁾
- 7) Cylinder retainer
- 8) Motor for rotary movement¹⁾

1) These parts must be ordered separately as accessories.

Motors

→ 16



- 1) Servo motor EMMS-AS
- 2) Stepper motor EMMS-ST
- 3) Motor unit MTR-DCI

 **Note**
A range of specially matched complete solutions is available for the rotary lifting module EHMB and motors.

Motor controllers

Technical data → Internet: motor controller

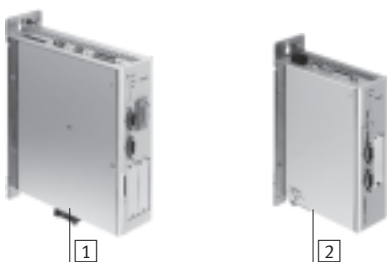

- 1) Servo motor controller CMMP-AS, CMMS-AS
- 2) Stepper motor controller CMMS-ST

Motor mounting kit

→ 16

Axial kit

Parallel kit



A range of complete kits is available for both parallel and axial motor mounting.

Rotary lifting modules EHMB, electric

Peripherals overview

Overview of peripherals

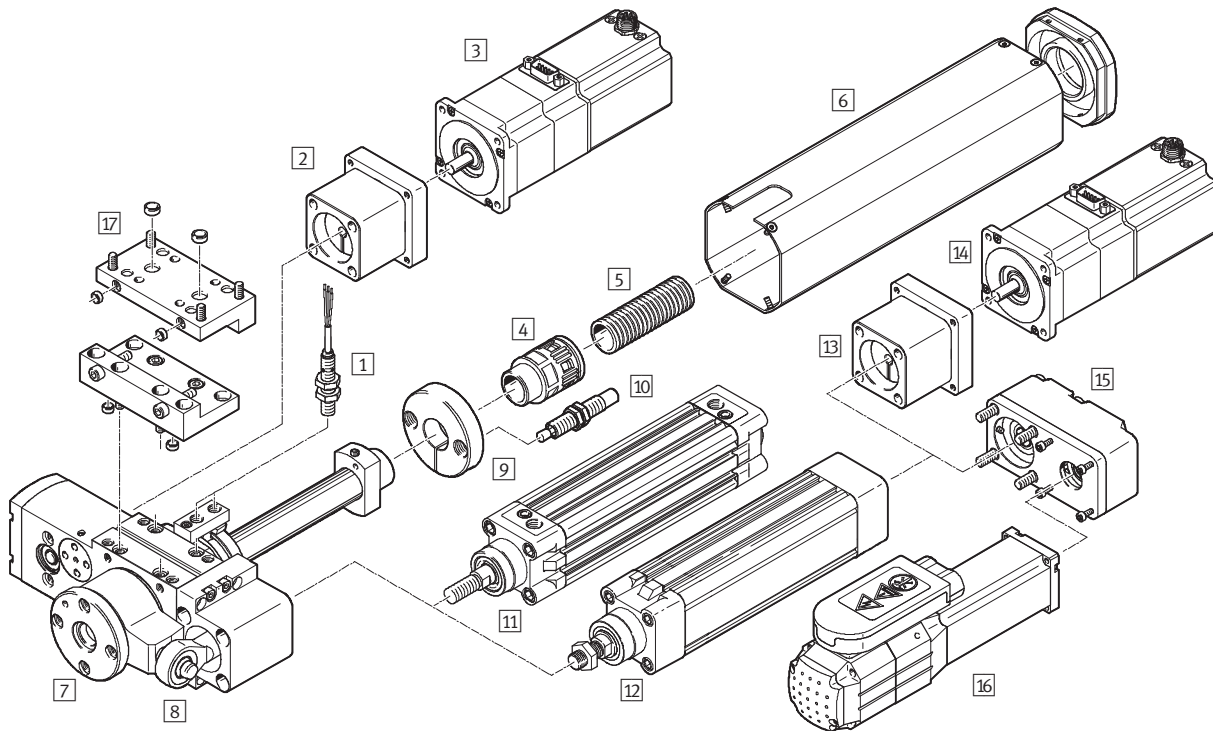

Accessory		
Type	Brief description	→ Page/Internet
1 Proximity sensor SIEN	<ul style="list-style-type: none"> For use as a proximity signal or safety monitor The retainer for the proximity sensor SIEN is included in the scope of delivery of the rotary lifting module Two cams → 25, for sensing positions, are included in the scope of delivery 	25
2 Axial kit EAMM-A	<ul style="list-style-type: none"> For the rotary movement of the rotary lifting module For axial motor mounting (consisting of: coupling, coupling housing and motor flange) 	21
3 Motor EMMS, MTR-DCI	<ul style="list-style-type: none"> For the rotary movement of the rotary lifting module Motors specially matched to the axis, with or without brake The motor can be mounted turned by 90° depending on the requirement. This means the connection side can be freely selected 	21
4 Protective conduit fitting EASA	For mounting the protective conduit	25
5 Protective conduit MKR	For protecting electrical cables and compressed air tubing	25
6 Cover EASC	For protection against accidental contact with the grooved-shaft guide and trip cams	24
7 Rotary lifting module EHMB	Combination of linear and rotary drive	6
8 Rod eye SGS	<ul style="list-style-type: none"> Connecting piece between rotary lifting module and standard/electric cylinder Included in the scope of delivery of the rotary lifting module 	24
9 Shock absorber retainer EAYH	Retainer for the shock absorber DYSW	24

Rotary lifting modules EHMB, electric

Peripherals overview and type codes

Accessory			
	Type	Brief description	→ Page/Internet
10	Shock absorber DYSW	Hydraulic shock absorber with path-controlled flow control function	24
11	Standard cylinder DNC	Pneumatic drive for the linear movement of the rotary lifting module	16
12	Electric cylinder DNCE	Electric drive for the linear movement of the rotary lifting module	16
13	Axial kit EAMM-A	<ul style="list-style-type: none"> For the linear movement of the rotary lifting module For axial motor mounting Alternative parallel kit 15 (consisting of: coupling, coupling housing and motor flange) 	17
14	Motor EMMS, MTR-DCI	<ul style="list-style-type: none"> For the linear movement of the rotary lifting module Motors specially matched to the axis, with or without brake The motor can be mounted turned by 90° depending on the requirement. This means the connection side can be freely selected 	17
15	Parallel kit EAMM-U	<ul style="list-style-type: none"> For the linear movement of the rotary lifting module For parallel motor mounting Alternative axial kit 13 (consisting of: housing, clamping component, clamping sleeve, toothed belt pulley, toothed belt) 	18
16	Motor EMMS, MTR-DCI	<ul style="list-style-type: none"> For the linear movement of the rotary lifting module Motors specially matched to the axis, with or without brake The motor can be mounted turned by 90° depending on the requirement. This means the connection side can be freely selected 	18
17	Adapter plate kit EHAM	<ul style="list-style-type: none"> For attachment to the axes EGC and DGC Screws and centring sleeves are included in the scope of delivery of the adapter plate kit 	24

 Note

When installing electric cables or compressed air tubing through the hollow shaft of the grooved-shaft guide, the rotation angle of the EHMB must be limited to a value that is dependent on the cables or compressed air tubing. Endless rotation damages cables and tubing.

Type codes

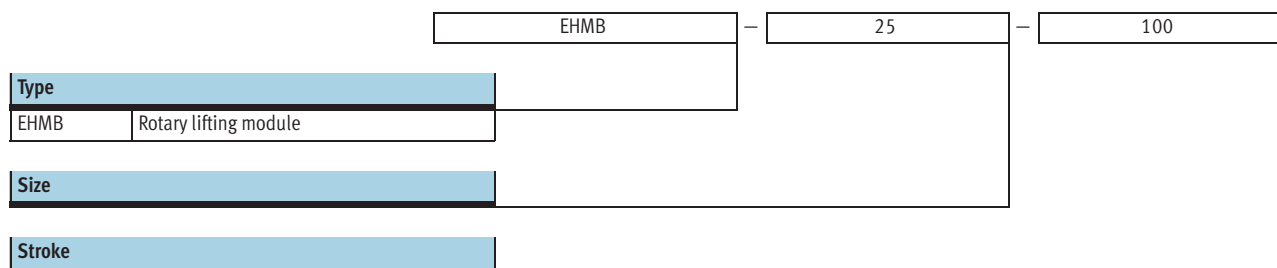

Rotary lifting modules EHMB, electric

Technical data

 Size
20, 25, 32

 Note
All values are based on a room temperature of 23 °C.

 www.festo.com



General technical data				
Size		20	25	32
Design		Electromechanical rotary lifting module with toothed belt		
Drive shaft \varnothing	[mm]	6	8	12
Rotation angle		Endless (→ 5)		
Stroke, linear	[mm]	100	200	
Repetition accuracy, rotary ¹⁾				
With servo motor EMMS-AS	[°]	±0.03		
With stepper motor EMMS-ST ²⁾	[°]	±0.08		
With motor unit MTR-DCI	[°]	±0.05		
Repetition accuracy, linear ¹⁾	[mm]	±0.02		
Max. speed, linear				
With standard cylinder DNC	[m/s]	→ 10		
With electric cylinder DNCE	[m/s]	0.5		0.64
Positioning times, rotary		→ 11		
Transmission ratio		4.5:1	4:1	3:1
Position sensing		Via proximity sensor		
Mounting position		Any		

1) As per FN 942 027, with electric cylinder DNCE
2) Dependent on the encoder solution

Mechanical data				
Size		20	25	32
Max. driving torque	[Nm]	0.7	2.2	6.7
Max. output torque ¹⁾	[Nm]	3.15	8.8	20
No-load driving torque ²⁾	[Nm]	< 0.07	< 0.18	< 0.5
Max. input speed	[rpm]	1,350	1,200	900
Max. output speed	[rpm]	300	300	300
Max. effective load, horizontal	[kg]	3	5	8
Max. effective load, vertical	[kg]	3	5	15 ³⁾
Max. mass moment of inertia ⁴⁾				
With servo motor EMMS-AS	[kgcm ²]	50	200	1 000
With stepper motor EMMS-ST	[kgcm ²]	30	100	500
With motor unit MTR-DCI-...-G7	[kgcm ²]	50	300	1,000
With motor unit MTR-DCI-...-G14	[kgcm ²]	200	1,200	3,700
Toothed belt pitch		2	3	5

1) Output torque less friction is dependent on speed
2) At maximum speed
3) With symmetrical and non-eccentric arrangement
4) Dependent on the size of the motor. Suitable motors → 21

Rotary lifting modules EHMB, electric

Technical data

Operating and environmental conditions			
Size	20	25	32
Ambient temperature [°C]	-10 ... +60		
Noise level L_{pEq} with cover [dB (A)]	57	56	53
Noise level L_{pEq} without cover [dB (A)]	54	51	51

Weight [g]						
Size	20		25		32	
Stroke [mm]	100	200	100	200	100	200
Product weight						
Total	1,716	1,851	3,347	3,620	6,112	6,388
Moving mass for linear movement						
Guide rod	501	681	1,251	1,651	1,332	1,732
Stop nut	25	25	53	53	53	53
Shock absorber retainer	64	64	99	99	99	99
Shock absorber	42	42	66	66	66	66
Rod eye	73	73	73	73	108	108
Moving mass of standard cylinder DNC	252	342	252	342	467	627

Materials

Sectional view

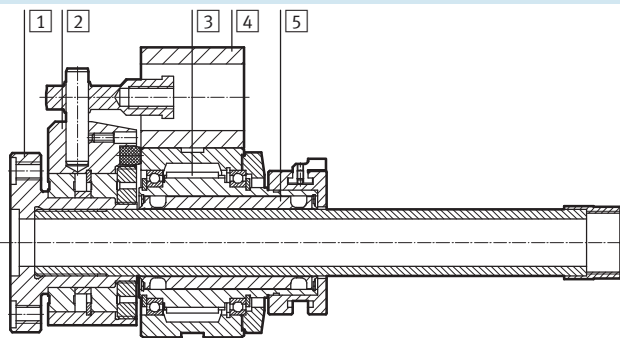

Rotary lifting module		
1	Flange	Anodised aluminium
2	Holder	Wrought aluminium alloy, anodised
3	Toothed belt	Polychloroprene with glass fibres
4	Retainer	Anodised aluminium
5	Output shaft	Steel
-	Drive shaft	High-alloy stainless steel
	Note on materials	Contains PWIS (paint wetting impairment substances)

Rotary lifting modules EHMB, electric

Technical data

Maximum radial and axial force F_y/F_z at the output shaft as a function of distance x/z

If the rotary module is subjected to two or more forces at once, the following equation must be satisfied in addition to the maximum loads indicated below.

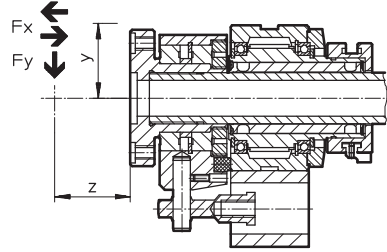

$$\frac{|F_x|}{F_{x_{max}}} + \frac{|F_y|}{F_{y_{max}}} + \frac{|F_z|}{F_{z_{max}}} \leq 1$$

Max. radial force F_y , dynamic

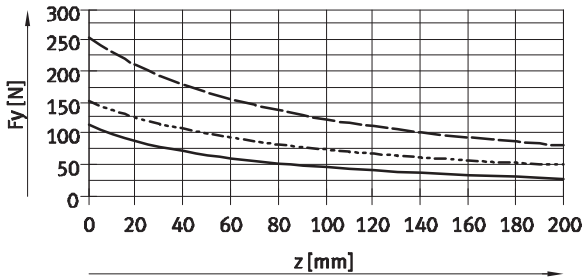

Max. axial force F_x , dynamic, pushing and pulling

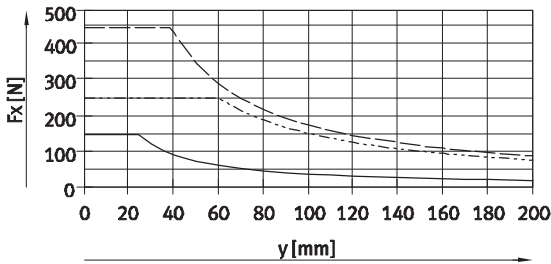

- EHMB-20
- - - EHMB-25
- · - EHMB-32

Rotary lifting modules EHMB, electric

Technical data

Deflection f as a function of lateral stroke F and stroke l

The following graphs show the deflection f of the rotary lifting module under radial forces and with two strokes.

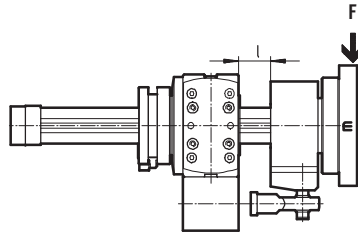

EHMB-20

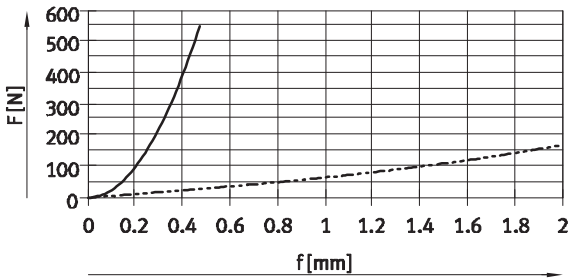

EHMB-25

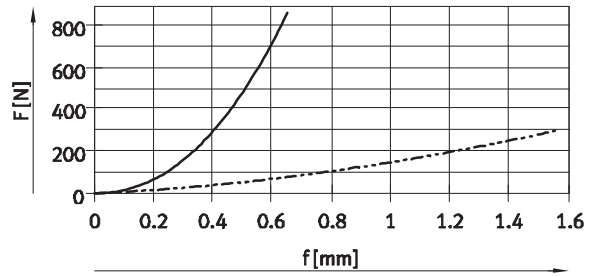

EHMB-32

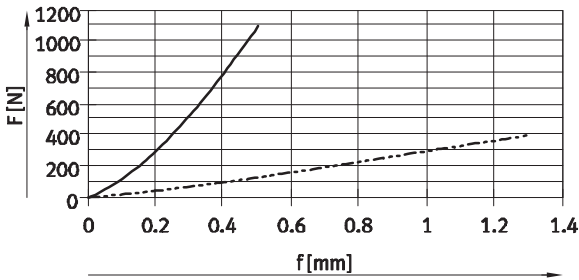

— $l = 10$ mm
 - - - $l = 200$ mm

Rotary lifting modules EHMB, electric

Technical data

Max. speed v as a function of effective load m , in combination with the pneumatic standard cylinder DNC

Mounting position:

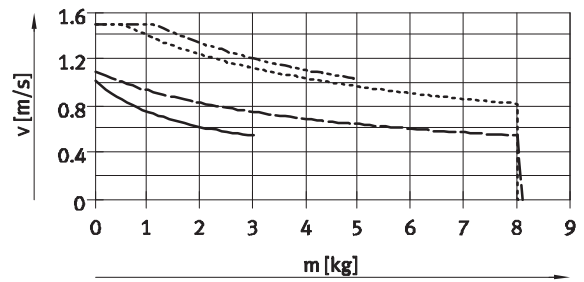
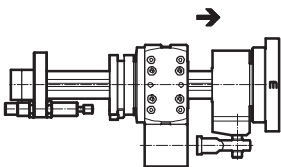
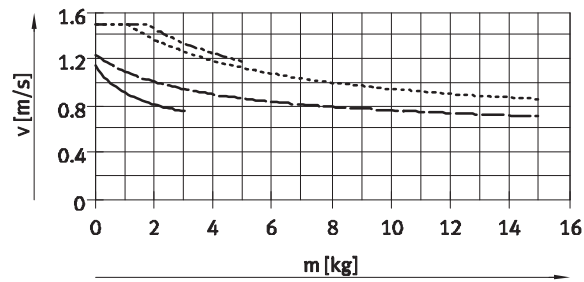
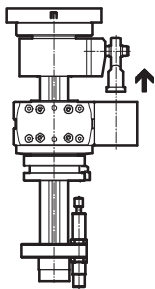
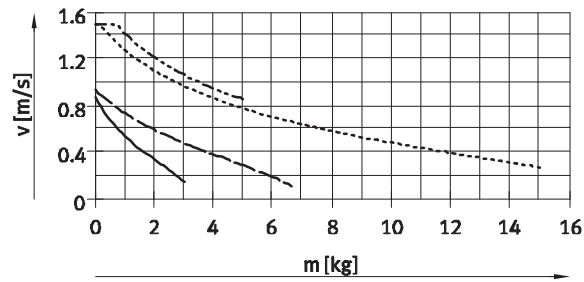
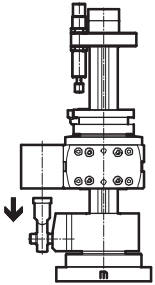

- EHMB-20
- - - EHMB-25
- · - · EHMB-32, with one shock absorber DYSW
- · - · - · EHMB-32, with two shock absorbers DYSW

Rotary lifting modules EHMB, electric

Technical data



FESTO

Positioning time t as a function of rotation angle α in combination with motor EMMS-.../motor unit MTR-DCI-...

Size 20

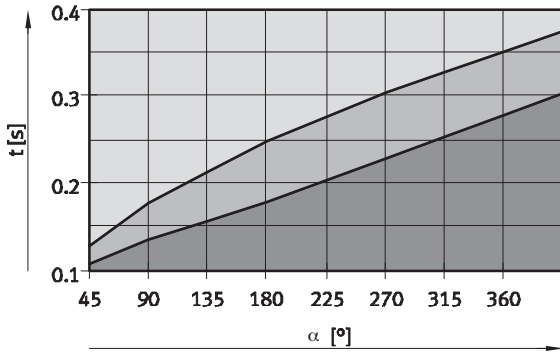

With servo motor EMMS-AS



-  Permissible range
-  The viability is dependent on the motor size and inertia of the load
-  Non-viable range

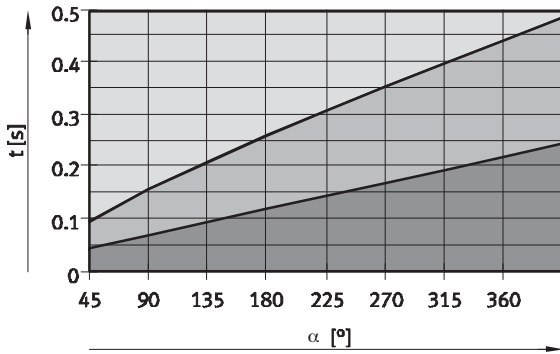

With stepper motor EMMS-ST

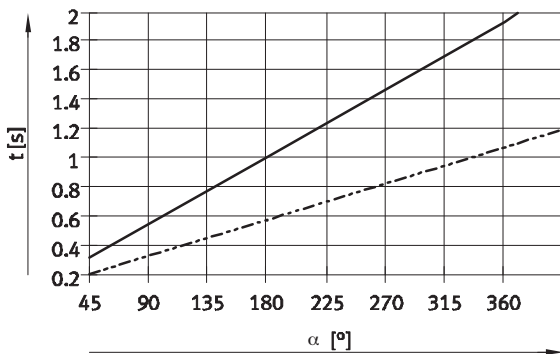

-  Permissible range
-  The viability is dependent on the motor size and inertia of the load
-  Non-viable range

With motor unit MTR-DCI



-  Limit range for MTR-DCI-32-G14 at 0 ... 200 kgcm²
-  Limit range for MTR-DCI-32-G7 at 0 ... 50 kgcm²

Rotary lifting modules EHMB, electric



Technical data

Positioning time t as a function of rotation angle α in combination with motor EMMS-.../motor unit MTR-DCI-...

Size 25

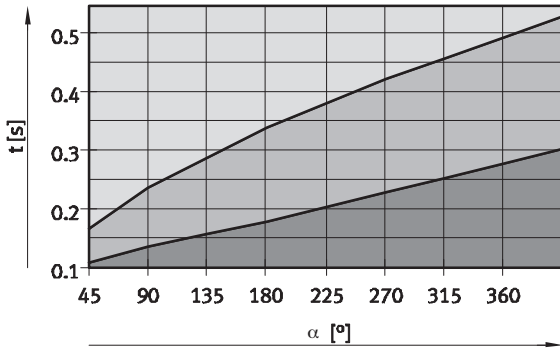

With servo motor EMMS-AS



-  Permissible range
-  The viability is dependent on the motor size and inertia of the load
-  Non-viable range

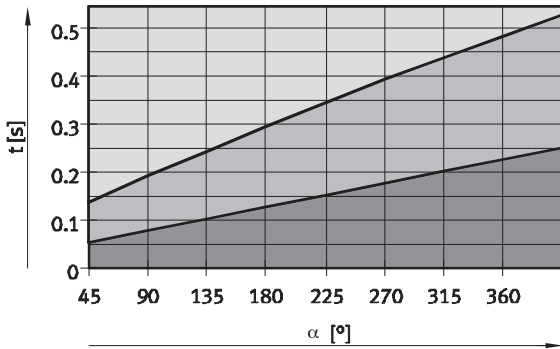

With stepper motor EMMS-ST

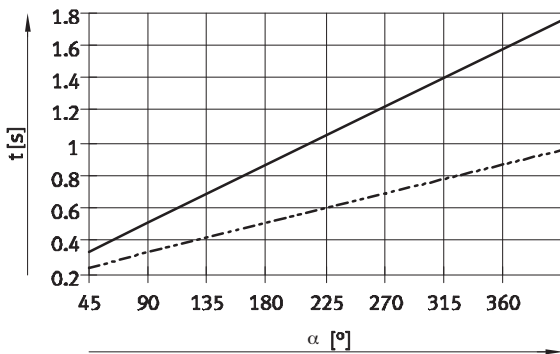

-  Permissible range
-  The viability is dependent on the motor size and inertia of the load
-  Non-viable range

With motor unit MTR-DCI



-  Limit range for MTR-DCI-42-G14 at 0 ... 1,200 kgcm²
-  Limit range for MTR-DCI-42-G7 at 0 ... 300 kgcm²

Rotary lifting modules EHMB, electric

Technical data

Positioning time t as a function of rotation angle α in combination with motor EMMS-.../motor unit MTR-DCI-...

Size 32

With servo motor EMMS-AS

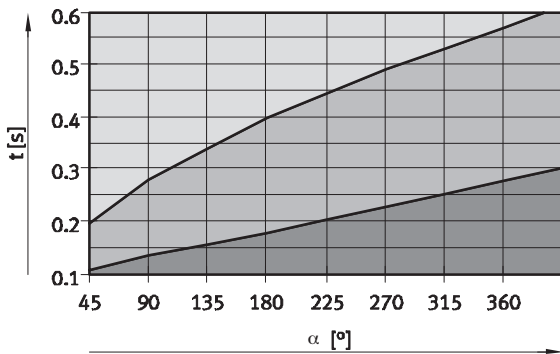

- Permissible range
- The viability is dependent on the motor size and inertia of the load
- Non-viable range

With stepper motor EMMS-ST

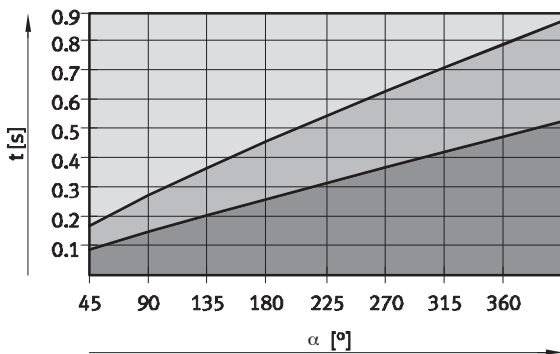

- Permissible range
- The viability is dependent on the motor size and inertia of the load
- Non-viable range

With motor unit MTR-DCI

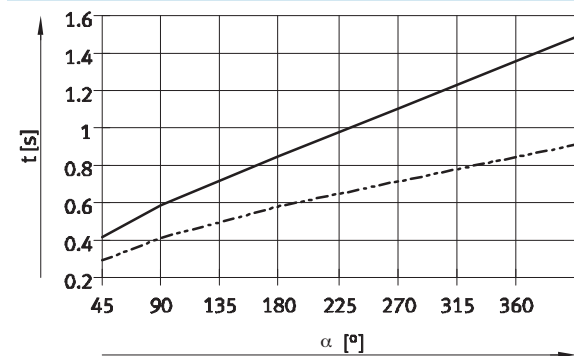

- Limit range for MTR-DCI-52-G14 at 0 ... 3,700 kgcm²
- Limit range for MTR-DCI-52-G7 at 0 ... 1,000 kgcm²

Rotary lifting modules EHMB, electric

Technical data

Dimensions

Download CAD data → www.festo.com

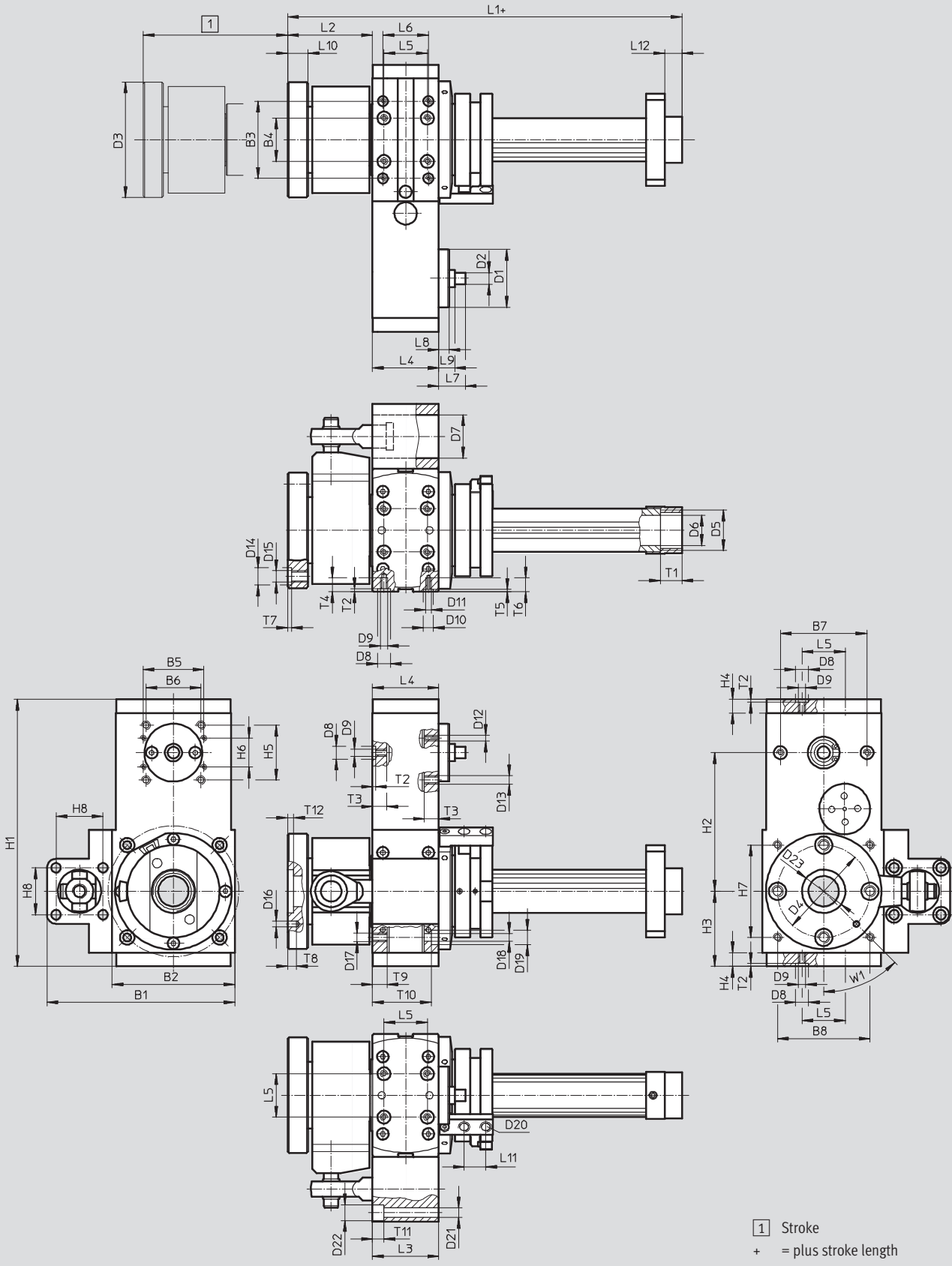

Rotary lifting modules EHMB, electric

Technical data

Size	B1 ±0.5	B2 ±0.2	B3 ¹⁾	B4 ¹⁾	B5 ±0.15	B6 ±0.15	B7 ¹⁾	B8 ±0.15	D1 ∅ g7	D2 ∅ h6	D3 ∅	D4 ∅ ±0.05
20	110	65	54	34	32	32.5	30	52	32	6	58	45
25	130	85	53.5	30	42	38	60	64	40	8	80	64
32	169.5	115	70	40	62	56.5	80	88	60	12	80	64

Size	D5	D6 ∅	D7 ∅ H8	D8 ∅ H7	D9	D10 ∅ H7	D11	D12	D13	D14 ∅ H7	D15	D16 ∅ H7
20	Pg16	14	30	9	M5	7	M4	M3	M6	9	M6	4
25	Pg21	21	30	9	M5	7	M4	M4	M6	12	M8	4
32	Pg21	21	35	9	M5	–	M5	M5	M8	12	M8	4

Size	D17	D18 ∅	D19 ∅	D20	D21 ∅	D22 ∅	D23 ∅	H1 ±0.5	H2 ±0.05	H3	H4	H5 ±0.15
20	M5	–	–	M8x1	6.6	11	19 ^{H8}	149	72	45	9.5	32.5
25	M6	5.5	10	M8x1	6.6	11	30 ^{H7}	185	96	52	9.5	38
32	M6	6.2	10	M8x1	6.6	11	30 ^{H7}	229.5	108	70.5	13	56.5

Size	H6 ±0.15	H7 ±0.15	H8	L1	L2 min.	L3 ±0.1	L4 ±0.1	L5 ¹⁾	L6 ¹⁾	L7	L8	L9	L10	L11 ±0.1
20	19	44	32.5	147.5	40.5	52	40	30	30	15.8	5	7.8	9	15
25	20	64	32.5	173	58.6	46	46	30	31.5	18.35	7	–	14	15
32	31	88	38	183	61.4	60	60	40	47	23.3	6	–	14	15

Size	L12	T1	T2 +0.1	T3	T4	T5 +0.2	T6	T7 +0.1	T8	T9	T10 ±0.2	T11	T12 ±0.5	W1
20	12	14	2.1	10	9	1.6	9.5	2.1	6	8.5	–	11	3	45°
25	12	15	2.1	10	9.6	1.6	9.5	2.7	6	10	40.8	8	4	45°
32	12	15	2.1	10	9	–	9.5	2.7	6	10	54.3	15	4	45°

1) Tolerance for centring hole ±0.02 mm
Tolerance for thread ±0.1 mm

Rotary lifting modules EHMB, electric

Technical data

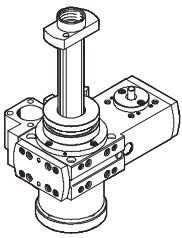
Ordering data				
	Size	Stroke [mm]	Part No.	Type
	20	100	1107096	EHMB-20-100
		200	1107097	EHMB-20-200
	25	100	1095933	EHMB-25-100
		200	1095934	EHMB-25-200
	32	100	1098558	EHMB-32-100
		200	1098559	EHMB-32-200

Cylinder connection for linear movement

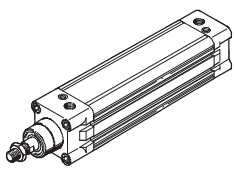
Ordering data			
In combination with pneumatic standard cylinder DNC		Technical data → Internet: dnc	
	For rotary lifting module	Standard cylinder DNC	
		Part No.	Type
	EHMB-20-100	163309	DNC-32-100-PPV-A
	EHMB-20-200	163312	DNC-32-200-PPV-A
	EHMB-25-100	163309	DNC-32-100-PPV-A
	EHMB-25-200	163312	DNC-32-200-PPV-A
	EHMB-32-100	163341	DNC-40-100-PPV-A
	EHMB-32-200	163344	DNC-40-200-PPV-A

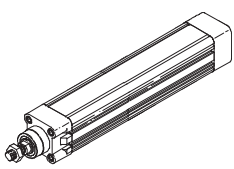
Ordering data			
In combination with electric cylinder DNCE		Technical data → Internet: dnce	
	For rotary lifting module	Electric cylinder DNCE	
		Part No.	Type
	EHMB-20-100	543115	DNCE-32-100-BS-”3”P-Q ¹⁾
	EHMB-20-200	543116	DNCE-32-200-BS-”3”P-Q ¹⁾
	EHMB-25-100	543115	DNCE-32-100-BS-”3”P-Q ¹⁾
	EHMB-25-200	543116	DNCE-32-200-BS-”3”P-Q ¹⁾
	EHMB-32-100	543127	DNCE-40-100-BS-”5”P-Q ²⁾
	EHMB-32-200	543128	DNCE-40-200-BS-”5”P-Q ²⁾

- 1) Linear ball screw drive with spindle pitch 3 mm, with reduced dynamic response
- 2) Linear ball screw drive with spindle pitch 5 mm, with reduced dynamic response

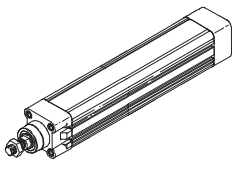
Ordering data			
In combination with electric cylinder DNCE		Technical data → Internet: dnce	
	For rotary lifting module	Electric cylinder DNCE	
		Part No.	Type
	EHMB-20-100	543119	DNCE-32-100-BS-”10”P-Q ³⁾
	EHMB-20-200	543120	DNCE-32-200-BS-”10”P-Q ³⁾
	EHMB-25-100	543119	DNCE-32-100-BS-”10”P-Q ³⁾
	EHMB-25-200	543120	DNCE-32-200-BS-”10”P-Q ³⁾
	EHMB-32-100	543131	DNCE-40-100-BS-”12,7”P-Q ⁴⁾
	EHMB-32-200	543132	DNCE-40-200-BS-”12,7”P-Q ⁴⁾



- 3) Linear ball screw drive with spindle pitch 10 mm
- 4) Linear ball screw drive with spindle pitch 12.7 mm

Rotary lifting modules EHMB, electric

Accessories

FESTO

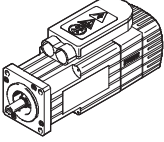
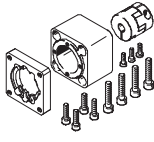
Motor connection for linear movement

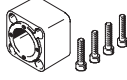
Permissible axis/motor combinations with axial kit				
Motor/motor unit	Axial kit	Axial kit consisting of:		
		Motor flange	Coupling	Coupling housing
				
Type	Part No. Type	Part No. Type	Part No. Type	Part No. Type
DNCE-32				
With servo motor				
EMMS-AS-40-...	543147 EAMM-A-D32-40A	552163 EAMF-A-28B-40A	543420 EAMC-16-20-6-6	552155 EAMK-A-D32-28B
EMMS-AS-55-...	550979 EAMM-A-D32-55A	529942 EAMF-A-44A/B-55A	551003 EAMC-30-32-6-9	551006 EAMK-A-D32-44A
With stepper motor				
EMMS-ST-42-...	543148 EAMM-A-D32-42A	552164 EAMF-A-28B-42A	543419 EAMC-16-20-5-6	552155 EAMK-A-D32-28B
EMMS-ST-57-...	550980 EAMM-A-D32-57A	530081 EAMF-A-44A/B-57A	551002 EAMC-30-32-6-6.35	551006 EAMK-A-D32-44A
With motor unit				
MTR-DCI-32S-... ¹⁾	543149 EAMM-A-D32-32B	–	543420 EAMC-16-20-6-6	552156 EAMK-A-D32-32B
DNCE-40				
With servo motor				
EMMS-AS-55-...	543153 EAMM-A-D40-55A	529942 EAMF-A-44A/B-55A	543423 EAMC-30-32-8-9	552157 EAMK-A-D40-44A
EMMS-AS-70-...	550981 EAMM-A-D40-70A	529943 EAMF-A-44A/B-70A	551004 EAMC-30-32-8-11	552157 EAMK-A-D40-44A
With stepper motor				
EMMS-ST-57-...	543154 EAMM-A-D40-57A	530081 EAMF-A-44A/B-57A	543421 EAMC-30-32-6.35-8	552157 EAMK-A-D40-44A
EMMS-ST-87-...	550982 EAMM-A-D40-87A	530082 EAMF-A-44A/B-87A	551004 EAMC-30-32-8-11	552157 EAMK-A-D40-44A
With motor unit				
MTR-DCI-42S-...-G7 ¹⁾	543155 EAMM-A-D40-42B	–	543422 EAMC-30-32-8-8	522158 EAMK-A-D40-42B
MTR-DCI-42S-...-G14 ¹⁾	543156 EAMM-A-D40-42C	–	543422 EAMC-30-32-8-8	522159 EAMK-A-D40-42C

 Note

1) The motor unit MTR-DCI must only be used in combination with the electric cylinder DNCE-...-LS (lead screw).
The maximum feed force of the cylinder may not be reached depending on the combination of motor/motor unit and electric cylinder.

The following tool is available for sizing:
PositioningDrives sizing software
→ www.festo.com

Rotary lifting modules EHMB, electric

Accessories

Motor connection for linear movement

Permissible axis/motor combinations with parallel kit

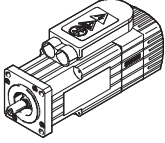
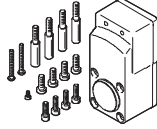
Motor/motor unit	Parallel kit	
		
Type	Part No.	Type
DNCE-32		
With servo motor		
EMMS-AS-40-...	543150	EAMM-U-D32-40A
With motor unit		
MTR-DCI-32S-...¹⁾	543152	EAMM-U-D32-32B
DNCE-40		
With servo motor		
EMMS-AS-55-...	543157	EAMM-U-D40-55A
With motor unit		
MTR-DCI-42S-...-G7¹⁾	543159	EAMM-U-D40-42B
MTR-DCI-42S-...-G14¹⁾	543160	EAMM-U-D40-42C

 **Note**

1) The motor unit MTR-DCI must only be used in combination with the electric cylinder DNCE-...-LS (lead screw).
The maximum feed force of the cylinder may not be reached depending on the combination of motor/motor unit and electric cylinder.
When using parallel kits, the respective no-load driving torque of the kit must be taken into consideration.

The following tool is available for sizing:
PositioningDrives
sizing software
→ www.festo.com

Rotary lifting modules EHMB, electric

Accessories

FESTO

Motor connection for linear movement

Axial kit EAMM-A-...

Materials:

Coupling housing, coupling hubs,

motor flange: Aluminium

Screws: Galvanised steel

Clamping component:

Corrosion-resistant steel

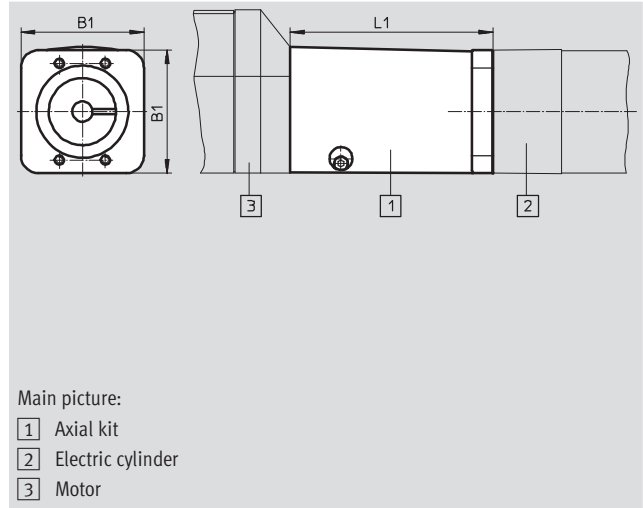

Main picture:

- 1 Axial kit
- 2 Electric cylinder
- 3 Motor

General technical data												
EAMM-A-...		D32-					D40-					
		32B	40A	42A	55A	57A	42B	42C	55A	57A	70A	87A
Transferable torque	[Nm]	1.1	1.1	0.8	4	4	8	8	8	6	8	8
Mass moment of inertia	[kg mm ²]	0.3	0.3	0.3	5.87	5.87	5.87	5.87	5.87	5.87	5.87	5.87
Max. rotational speed	[rpm]	10,000			8,000		8,000					
Mounting position		Any										

Operating and environmental conditions		
Ambient temperature	[°C]	0 ... 50
Storage temperature	[°C]	-25 ... +60
Protection class ¹⁾		IP40
Relative air humidity	[%]	0 ... 95

1) Only in combination with attached motor and axis

Dimensions and ordering data					
Type	B1	L1	Weight [g]	Part No.	Type
EAMM-A-D32-32B	45	43	150	543149	EAMM-A-D32-32B
EAMM-A-D32-40A		39.8	130	543147	EAMM-A-D32-40A
EAMM-A-D32-42A		48	140	543148	EAMM-A-D32-42A
EAMM-A-D32-55A	55	49.2	260	550979	EAMM-A-D32-55A
EAMM-A-D32-57A	56.4	50.5	270	550980	EAMM-A-D32-57A
EAMM-A-D40-42B	53.5	88	340	543155	EAMM-A-D40-42B
EAMM-A-D40-42C		101	370	543156	EAMM-A-D40-42C
EAMM-A-D40-55A		49.2	350	543153	EAMM-A-D40-55A
EAMM-A-D40-57A		50.5	350	543154	EAMM-A-D40-57A
EAMM-A-D40-70A	70	52	410	550981	EAMM-A-D40-70A
EAMM-A-D40-87A	85.8	54	530	550982	EAMM-A-D40-87A

Rotary lifting modules EHMB, electric

Accessories

Motor connection for linear movement

Parallel kit EAMM-U-...

Materials:

- Housing: Die-cast aluminium
- Clamping component, clamping sleeve, toothed belt pulley: Corrosion-resistant steel
- Toothed belt: Polychloroprene
- Screws: Galvanised steel

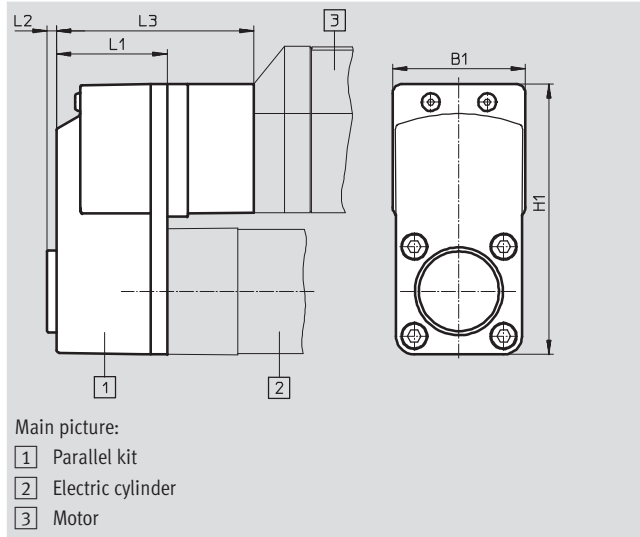

General technical data						
EAMM-U-...		D32-		D40-		
		32B	40A	42B	42C	55A
Transferable torque	[Nm]	1	1	3	3	3
No-load driving torque	[Nm]	0.05	0.05	0.1	0.1	0.1
Mass moment of inertia	[kgmm ²]	2.931	2.931	10.016	10.016	10.016
Max. rotational speed	[rpm]	3,000				
Mounting position		Any				

Operating and environmental conditions		
Ambient temperature	[°C]	0 ... 50
Storage temperature	[°C]	-25 ... +60
Protection class ¹⁾		IP40
Relative air humidity	[%]	0 ... 95



1) Only in combination with attached motor and axis

Dimensions and ordering data								
Type	B1	H1	L1	L2	L3	Weight [g]	Part No.	Type
EAMM-U-D32-32B	45.1	93.1	40	4	-	300	543152	EAMM-U-D32-32B
EAMM-U-D32-40A						300	543150	EAMM-U-D32-40A
EAMM-U-D40-42B	56.5	115	47	4	84	660	543159	EAMM-U-D40-42B
EAMM-U-D40-42C					97	690	543160	EAMM-U-D40-42C
EAMM-U-D40-55A					-	530	543157	EAMM-U-D40-55A

Rotary lifting modules EHMB, electric

Accessories

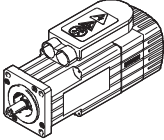
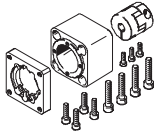
Motor connection for rotary movement

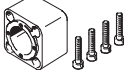

Permissible axis/motor combinations with axial kit – Without gear unit				
Motor/motor unit	Axial kit	Axial kit consisting of:		
		Motor flange	Coupling	Coupling housing
				
Type	Part No. Type	Part No. Type	Part No. Type	Part No. Type
EHMB-20				
With servo motor				
EMMS-AS-40-...	560281 EAMM-A-D32-35A-40A	–	558312 EAMC-30-32-6-6	560280 EAMK-A-D32-35-40A
With stepper motor				
EMMS-ST-42-...	543148 EAMM-A-D32-42A	552164 EAMF-A-28B-42A	543419 EAMC-16-20-5-6	552155 EAMK-A-D32-28B
EMMS-ST-57-S-...	550980 EAMM-A-D32-57A	530081 EAMF-A-44A/B-57A	551002 EAMC-30-32-6-6.35	551006 EAMK-A-D32-44A
With motor unit				
MTR-DCI-32S-...	543149 EAMM-A-D32-32B	–	543420 EAMC-16-20-6-6	552156 EAMK-A-D32-32B
EHMB-25				
With servo motor				
EMMS-AS-55-...	543153 EAMM-A-D40-55A	529942 EAMF-A-44A/B-55A	543423 EAMC-30-32-8-9	552157 EAMK-A-D40-44A
EMMS-AS-70-S-...	550981 EAMM-A-D40-70A	529943 EAMF-A-44A/B-70A	551004 EAMC-30-32-8-11	552157 EAMK-A-D40-44A
With stepper motor				
EMMS-ST-57-...	543154 EAMM-A-D40-57A	530081 EAMF-A-44A/B-57A	543421 EAMC-30-32-6.35-8	552157 EAMK-A-D40-44A
With motor unit				
MTR-DCI-42S-...-G7	543155 EAMM-A-D40-42B	–	543422 EAMC-30-32-8-8	552158 EAMK-A-D40-42B
MTR-DCI-42S-...-G14	543156 EAMM-A-D40-42C	–	543422 EAMC-30-32-8-8	552159 EAMK-A-D40-42C
EHMB-32				
With servo motor				
EMMS-AS-70-M-...	543161 EAMM-A-D60-70A	529945 EAMF-A-64A/B-70A	543424 EAMC-42-50-11-12	552160 EAMK-A-D60-64B
EMMS-AS-100-S-...	550983 EAMM-A-D60-100A	529947 EAMF-A-64A/C-100A	551005 EAMC-42-50-12-19	551007 EAMK-A-D60-64C
With stepper motor				
EMMS-ST-87-M-...	543162	533140	543424	552160
EMMS-ST-87-L-...	EAMM-A-D60-87A	EAMF-A-64A/B-87A	EAMC-42-50-11-12	EAMK-A-D60-64B
With motor unit				
MTR-DCI-52S-...-G7	543163 EAMM-A-D60-52B	–	533709 EAMC-42-50-12-12	552161 EAMK-A-D60-52B
MTR-DCI-52S-...-G14	543164 EAMM-A-D60-52C	–	533709 EAMC-42-50-12-12	552162 EAMK-A-D60-52C

Rotary lifting modules EHMB, electric

Accessories

Motor connection for rotary movement

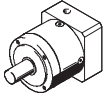
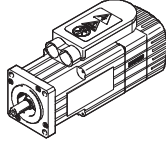
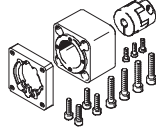
Permissible axis/motor combinations with axial kit – With gear unit

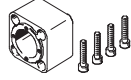
Gear unit	Motor	Axial kit	Axial kit consisting of:		
			Motor flange	Coupling	Coupling housing
					
Type	Type	Part No. Type	Part No. Type	Part No. Type	Part No. Type
EHMB-25					
With servo motor					
EMGA-40-P-G3-SAS-40	EMMS-AS-40-...	560282 EAMM-A-D40-40G	550986 EAMF-A-44A/B-40G	558029 EAMC-30-32-8-10	552157 EAMK-A-D40-44A
EHMB-32					
With servo motor					
EMGA-60-P-G...-SAS-55	EMMS-AS-55-...	560283 EAMM-A-D60-60G	550987 EAMF-A-64A/B-60G	543424 EAMC-42-50-11-12	552160 EAMK-A-D60-64B
EMGA-60-P-G3-SAS-70	EMMS-AS-70-...	560283 EAMM-A-D60-60G	550987 EAMF-A-64A/B-60G	543424 EAMC-42-50-11-12	552160 EAMK-A-D60-64B

 **Note**

Note the maximum permissible driving torque of the EHMB. The motor current may also need to be limited.

The following tool is available for sizing:
PositioningDrives sizing software
→ www.festo.com

Rotary lifting modules EHMB, electric

Accessories

FESTO

Motor connection for rotary movement

Axial kit EAMM-A-...

Materials:

Coupling housing, coupling hubs,

motor flange: Aluminium

Screws: Galvanised steel

Clamping component:

Corrosion-resistant steel

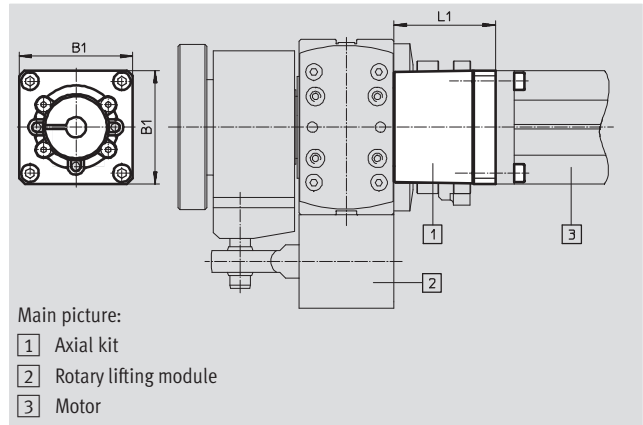
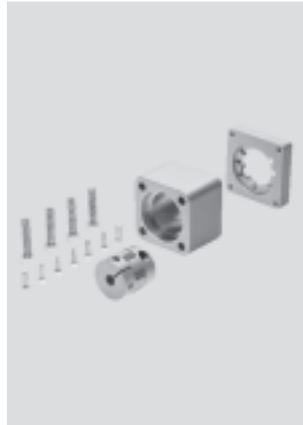

General technical data								
EAMM-A-...		D32-				D40-		
		32B	35-40A	42A	57A	42B	42C	55A
Transferable torque	[Nm]	1.1	4.0	0.8	4.0	8.0		6.0
Mass moment of inertia	[kgmm ²]	0.3	5.87	0.3	5.87	5.87		
Mounting position		Any				Any		

EAMM-A-...		D40-		D60-					
		70A	40G	52B	52C	70A	87A	100A	60G
Transferable torque	[Nm]	8.0		14.0		12.0		14.0	12.0
Mass moment of inertia	[kgmm ²]	5.87		35.5					
Mounting position		Any							

Operating and environmental conditions		
Ambient temperature	[°C]	0 ... 50
Storage temperature	[°C]	-25 ... +60
Protection class ¹⁾		IP40
Relative air humidity	[%]	0 ... 95

1) Only in combination with attached motor and axis

Dimensions and ordering data						
Type	B1	L1	Weight [g]	Part No.	Type	
EAMM-A-D32-32B	45	43	150	543149	EAMM-A-D32-32B	
EAMM-A-D32-35A-40A	40	46	220	560281	EAMM-A-D32-35A-40A	
EAMM-A-D32-42A	45	48	140	543148	EAMM-A-D32-42A	
EAMM-A-D32-57A	45	50.5	270	550980	EAMM-A-D32-57A	
EAMM-A-D40-42B	53.5	88	340	543155	EAMM-A-D40-42B	
EAMM-A-D40-42C	53.5	101	370	543156	EAMM-A-D40-42C	
EAMM-A-D40-40G	53.5	55.5	350	560282	EAMM-A-D40-40G	
EAMM-A-D40-55A	53.5	49.2	350	543153	EAMM-A-D40-55A	
EAMM-A-D40-57A	53.5	50.5	350	543154	EAMM-A-D40-57A	
EAMM-A-D40-70A	53.5	52	410	550981	EAMM-A-D40-70A	
EAMM-A-D60-52B	74	112	930	543163	EAMM-A-D60-52B	
EAMM-A-D60-52C	74	126	1,020	543164	EAMM-A-D60-52C	
EAMM-A-D60-60G	74	71.4	830	560283	EAMM-A-D60-60G	
EAMM-A-D60-70A	74	63.2	750	543161	EAMM-A-D60-70A	
EAMM-A-D60-87A	74	64.7	890	543162	EAMM-A-D60-87A	
EAMM-A-D60-100A	74	78.2	1,170	550983	EAMM-A-D60-100A	

Rotary lifting modules EHMB, electric

Accessories

Rod eye SGS

Scope of delivery:

1 rod eye, 1 hex nut to DIN 439

Material:

Galvanised steel

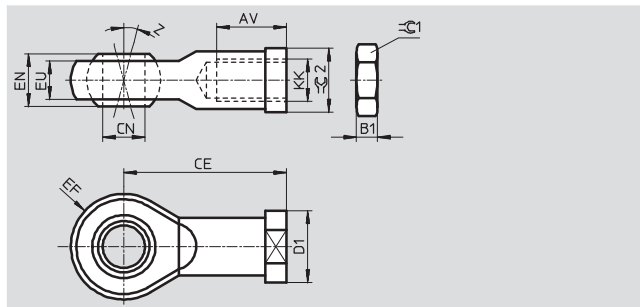

Dimensions and ordering data								
For size	AV	B1	CE	CN Ø H7	D1 Ø	EF ±0.5	EN	EU
20, 25	20 -2	5	43	10	19	14	14	10.5
32	22 -2	6	50	12	22	16	16	12

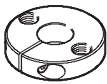
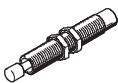
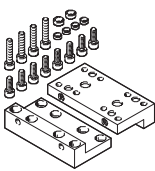

For size	EU	KK	Z	≈C1	≈C2	Part No.	Type
20, 25	10.5	M10x1.25	13	17	17	9261	SGS-M10x1,25
32	12	M12x1.25	13	19	19	9262	SGS-M12x1,25

Ordering data						
	For size	Brief description	Weight [g]	Part No.	Type	PU ¹⁾
Cover EASC						
	20	For protecting the grooved-shaft guide	303	1099901	EASC-H1-20-100	1
	25		388	1099902	EASC-H1-20-200	
			385	1096387	EASC-H1-25-100	
			482	1096388	EASC-H1-25-200	
			32	383	1107235	
		481	1107236	EASC-H1-32-200		
Shock absorber retainer EAYH						
	20	For mounting the shock absorber	68	1153896	EAYH-H1-20	1
	25, 32		106	1153905	EAYH-H1-25	
Shock absorber DYSW						
	20	Progressive shock absorber	42	548073	DYSW-8-14-Y1F	1
	25, 32		67	548074	DYSW-10-17-Y1F	
Adapter plate kit EHAM						
	20	For attachment to the axes EGC and DGC	288	1132369	EHAM-H1-20-L2-80	1
	25		292	1132402	EHAM-H1-25-L2-80	
	32		668	1132529	EHAM-H1-32-L2-120	

1) Packaging unit quantity

Rotary lifting modules EHMB, electric

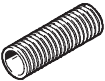
Accessories

Ordering data						
	For size	Brief description	Weight [g]	Part No.	Type	PU ¹⁾
Protective conduit fitting EASA						
	20	For mounting the protective conduit	8	1157774	EASA-H1-20-PG16	1
	25, 32		12	1096549	EASA-H1-25-PG21	
Protective conduit MKR						
	20	For protecting cables and tubing	–	177566	MKR-16,5-PG-16	–
	25, 32		–	177567	MKR-23-PG-21	
Cam EAPS						
	20	For sensing positions (2 cams included in the scope of delivery)	11	1234887	EAPS-H1-20-CK	2
	25, 32		11	1234888	EAPS-H1-25-CK	
Centring sleeve ZBH						
	– ²⁾	For centring loads and attachments	1	186717	ZBH-7	10
			1	150927	ZBH-9	
			1	189653	ZBH-12	

1) Packaging unit quantity

2) → Dimensional drawing 14

Ordering data – Proximity sensors, inductive				Technical data → Internet: sien	
	Contact	Connection	Part No.	Type	
	N/O contact	Cable, 2.5 m	150386	SIEN-M8B-PS-K-L	
		Plug	150387	SIEN-M8B-PS-S-L	
	N/C contact	Cable, 2.5 m	150390	SIEN-M8B-PO-K-L	
		Plug	150391	SIEN-M8B-PO-S-L	

 **Note**

The retainer for the proximity sensor SIEN is included in the scope of delivery of the rotary lifting module.

Ordering data – Connecting cables				Technical data → Internet: nebu	
	Electrical connection, left	Electrical connection, right	Cable length [m]	Part No.	Type
	Straight socket, M8x1, 3-pin	Cable, open end, 3-wire	2.5	541333	NEBU-M8G3-K-2.5-LE3
			5	541334	NEBU-M8G3-K-5-LE3