

Tandem/high-force cylinders

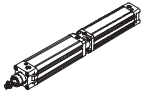
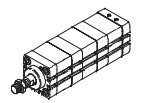

Tandem/high-force cylinders

Product range overview

Function	Version	Type	Piston Ø [mm]	Stroke [mm]	Position sensing A	Piston rod		
						With male thread	With female thread	
Double-acting	Tandem cylinders							
		DNCT	32, 40, 50	2 ... 500	■	■	-	
			63, 80, 100, 125	3 ... 500				
	High-force cylinders							
		ADNH	2x 25, 3x 25, 4x 25	1 ... 150	■	■	■	
			2x 40, 3x 40, 4x 40	1 ... 150				
			2x 63, 3x 63, 4x 63	1 ... 150				
			2x 100, 3x 100, 4x 100	1 ... 150				

Special features

General	DNCT	ADNH
By connecting 2, 3 or 4 cylinders with the same piston diameter and stroke in series, the force in the advance stroke (thrust) can be doubled, tripled or quadrupled in comparison to a single cylinder.	<ul style="list-style-type: none"> A maximum of 2 cylinders can be combined. Like the thrust, the force in the return stroke is double that of a single cylinder with corresponding piston diameter. 	<ul style="list-style-type: none"> A maximum of 4 cylinders can be combined. The internal distribution of compressed air means that only 2 connections are required to pressurise all cylinders. The force in the return stroke corresponds to that of a single cylinder with corresponding piston diameter.

Tandem/high-force cylinders

Product range overview

Type	Cushioning		Extended male thread K2	Special thread K5	Extended piston rod K8	Heat resistant up to 120 °C S6	→ Page/Internet
	Non-adjustable P	Adjustable PPV					
Tandem cylinders							
DNCT	-	■	-	-	-	■	4
High-force cylinders							
ADNH	■	-	■	■	■	■	20

Tandem cylinders DNCT, standard port pattern

Peripherals overview

FESTO

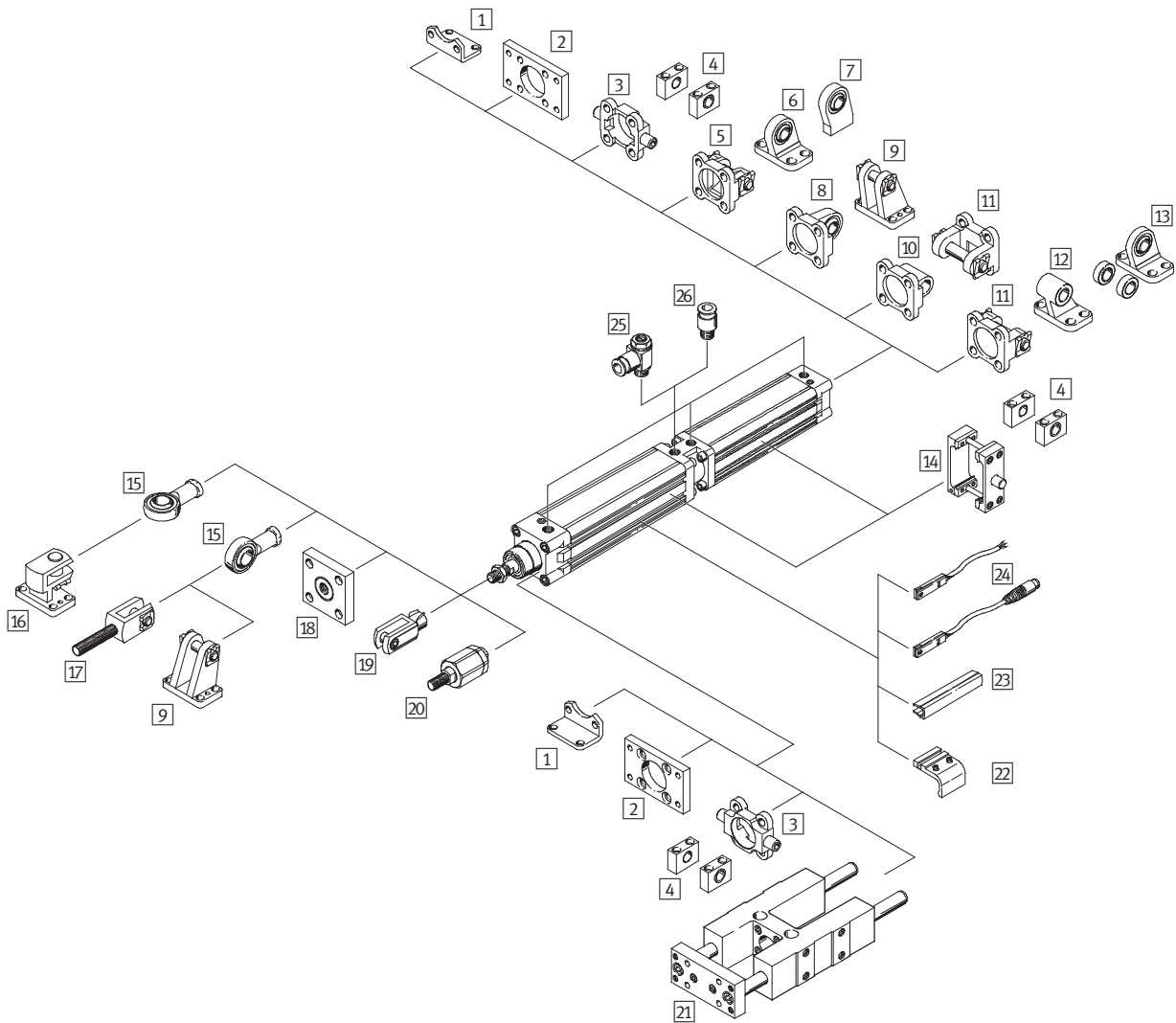

Tandem cylinders DNCT, standard port pattern

Peripherals overview

FESTO

Mounting attachments and accessories		
	Brief description	→ Page/Internet
1	Foot mounting HNC	For bearing and end caps 10
2	Flange mounting FNC	For bearing or end caps 10
3	Trunnion flange ZNCF	For bearing or end caps 11
4	Trunnion support LNZG	– 13
5	Swivel flange SNC	For end caps 13
6	Clevis foot LSNG	With spherical bearing 16
7	Clevis foot LSNSG	Weld-on, with spherical bearing 16
8	Swivel flange SNCS	With spherical bearing for end caps 14
9	Clevis foot LBG	– 16
10	Swivel flange SNCL	For end caps 15
11	Swivel flange SNCB	For end caps 14
12	Clevis foot LNG	– 16
13	Clevis foot LSN	With spherical bearing 16
14	Trunnion mounting kit ZNCM	For mounting anywhere on the cylinder profile barrel 12
15	Rod eye SGS	With spherical bearing 17
16	Right-angle clevis foot LQG	– 16
17	Rod clevis SGA	With male thread 17
18	Coupling piece KSG	For compensating radial deviations 17
19	Rod clevis SG	Permits a swivelling movement of the cylinder in one plane 17
20	Self-aligning rod coupler FK	For compensating radial and angular deviations 17
21	Guide unit FENG	For protecting standard cylinders from torsion at high torque loads 18
22	Mounting kit SMB-8-FENG	For proximity sensor SMT-8 when attaching to cylinders in combination with guide unit FENG 18
23	Slot cover ABP-5-S	To protect the sensor cable and keep dirt out of the sensor slots 19
24	Proximity sensor SME/SMT-8	Can be integrated in the cylinder profile barrel 19
25	One-way flow control valve GRLA	To regulate speed 17
26	Push-in fitting QS	For connecting compressed air tubing with standard external diameters quick star

Tandem cylinders DNCT, standard port pattern

Type codes

		DNCT	-	40	-	80	-	PPV	-	A	-	S6
Type												
Double-acting												
DNCT	Tandem cylinder											
Piston Ø [mm]												
Stroke [mm]												
Cushioning												
PPV	Pneumatic cushioning adjustable at both ends											
Position sensing												
A	For proximity sensing											
Variant												
S6	Heat-resistant up to 120 °C											

Tandem cylinders DNCT, standard port pattern

Technical data

Function

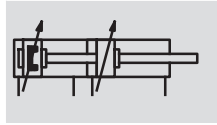

- \varnothing - Diameter
32 ... 125 mm

- | - Stroke length
 \varnothing 32 ... 50:
2 ... 500 mm

\varnothing 63 ... 125:
3 ... 500 mm

-  - www.festo.com

Variants



S6

Based on standard

- DIN ISO 6431
- VDMA 24562



General technical data							
Piston \varnothing	32	40	50	63	80	100	125
Pneumatic connection	G1/8	G1/4	G1/4	G3/8	G3/8	G1/2	G1/2
Piston rod thread	M10x1.25	M12x1.25	M16x1.5	M16x1.5	M20x1.5	M20x1.5	M27x2
Constructional design	Piston						
	Piston rod						
	Cylinder barrel						
Cushioning	Pneumatic cushioning adjustable at both ends						
Cushioning length [mm]	20	20	22	22	32	32	42
Position sensing	For proximity sensing						
Type of mounting	With female thread						
	Via accessories						
Mounting position	Any						

Operating conditions							
Piston \varnothing	32	40	50	63	80	100	125
Operating medium	Filtered compressed air, lubricated or unlubricated						
Operating pressure [bar]	0.6 ... 10						

Ambient conditions		
Tandem cylinder	Basic version	S6
Ambient temperature ¹⁾ [°C]	-20 ... +80	0 ... +120
Corrosion resistance class CRC ²⁾	2	2

1) Note operating range of proximity sensors

2) Corrosion resistance class 2 according to Festo standard 940 070

Components requiring moderate corrosion resistance. Externally visible parts with primarily decorative surface requirements which are in direct contact with a surrounding industrial atmosphere or media such as cooling or lubricating agents

Forces [N] and impact energy [J]							
Piston \varnothing	32	40	50	63	80	100	125
Theoretical force at 6 bar, advancing	898	1,387	2,168	3,552	5,737	9,130	14,244
Theoretical force at 6 bar, retracting	830	1,266	1,980	3,364	5,442	8,836	13,762
Max. impact energy at end positions	0.1	0.2	0.2	0.5	0.9	1.2	5

Tandem cylinders DNCT, standard port pattern

Technical data

Materials

Sectional view

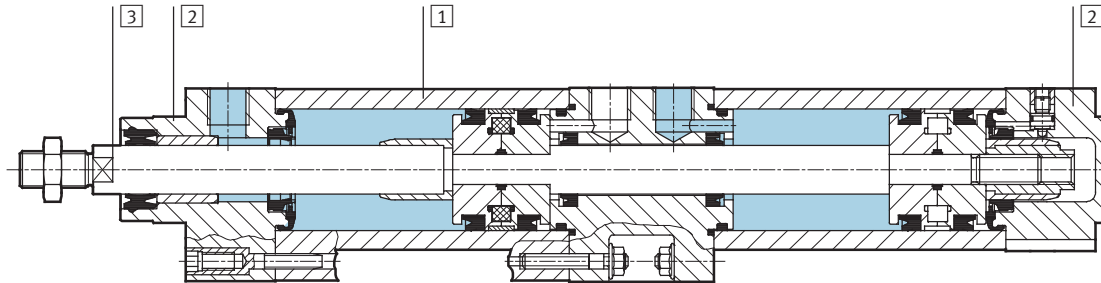

Tandem cylinder	Basic version	S6
1 Cylinder barrel	Wrought aluminium alloy, smooth anodised	Wrought aluminium alloy, smooth anodised
2 Bearing and end cap	Die-cast aluminium	Die-cast aluminium
3 Piston rod	High-alloy steel	High-alloy steel
- Seals	Polyurethane, nitrile rubber	Fluorocarbon rubber
Note on materials	RoHS compliant	

Dimensions

Download CAD data → www.festo.com

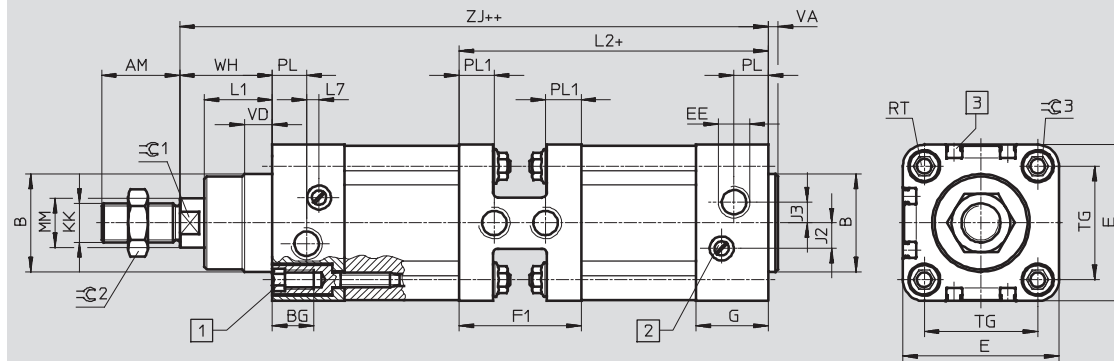



- 1 Socket head screw with female thread for mounting attachments
 - 2 Regulating screw for adjustable end position cushioning
 - 3 Sensor slot for proximity sensor
- + = plus stroke length
++ = plus 2x stroke length

∅	AM	B	BG	E	EE	F1	G	J2	J3	KK	L1	L2	L7
[mm]		∅ d11											
32	22	30	16	45.5	G $\frac{3}{8}$	35	25.1	6	5.2	M10x1.25	18	104.2	3.3
40	24	35	16	54	G $\frac{1}{4}$	47.6	29.6	8	6	M12x1.25	21.5	123.5	3.6
50	32	40	17	64	G $\frac{1}{4}$	50	29.6	10.4	8.5	M16x1.5	28	126.7	5.1
63	32	45	17	75	G $\frac{3}{8}$	64.4	35.6	12.4	10	M16x1.5	28.5	150	6.6
80	40	45	17	93	G $\frac{3}{8}$	68	35.9	12.5	8	M20x1.5	34.7	161.7	10.5
100	40	55	17	110	G $\frac{1}{2}$	75	38.8	12	10	M20x1.5	38.2	178.1	8
125	54	60	22	134	G $\frac{1}{2}$	70	44.7	13	8	M27x2	46	188.5	14

∅	MM	PL	PL1	RT	TG	VA	VD	WH	ZJ	∅C1	∅C2	∅C3
[mm]	∅											
32	12	15.1	9	M6	32.5	4	10	26.2 ±0.7	199.6 ±0.7	10	16	6
40	16	14	13.3	M6	38	4	10.5	30 +0.7/-0.9	229.4 +0.7/-0.9	13	18	6
50	20	14	14.5	M8	46.5	4	11.5	37.7 +0.7/-0.9	241.1 +0.7/-0.9	17	24	8
63	20	17	17.2	M8	56.5	4	15	38.2 +0.7/-0.9	273.9 +0.7/-0.9	17	24	8
80	25	16.4	19	M10	72	4	15.7	46.2 +0.7/-1.4	301.6 +0.7/-1.4	22	30	6
100	25	18.8	21	M10	89	4	19.2	50.1 +0.7/-1.4	331.3 +0.7/-1.4	22	30	6
125	32	18	18.5	M12	110	6	20.5	65.3 +0.7/-1.4	372.3 +0.7/-1.4	27	36	8

Tandem cylinders DNCT, standard port pattern

Technical data

Ordering data			
Type	Piston Ø [mm]	Stroke [mm]	Part No. Type
Basic version			
	32	2 ... 500	191 106 DNCT-32-...-PPV-A
	40	2 ... 500	191 107 DNCT-40-...-PPV-A
	50	2 ... 500	191 108 DNCT-50-...-PPV-A
	63	3 ... 500	191 109 DNCT-63-...-PPV-A
	80	3 ... 500	191 110 DNCT-80-...-PPV-A
	100	3 ... 500	191 111 DNCT-100-...-PPV-A
	125	3 ... 500	191 112 DNCT-125-...-PPV-A
S6 – Heat-resistant seals up to 120 °C			
	32	2 ... 500	191 210 DNCT-32-...-PPV-A-S6
	40	2 ... 500	191 211 DNCT-40-...-PPV-A-S6
	50	2 ... 500	191 212 DNCT-50-...-PPV-A-S6
	63	3 ... 500	191 213 DNCT-63-...-PPV-A-S6
	80	3 ... 500	191 214 DNCT-80-...-PPV-A-S6
	100	3 ... 500	191 215 DNCT-100-...-PPV-A-S6
	125	3 ... 500	191 216 DNCT-125-...-PPV-A-S6

Tandem cylinders DNCT, standard port pattern

Accessories

Foot mounting HNC

Material:
Galvanised steel
Free of copper, PTFE and silicone

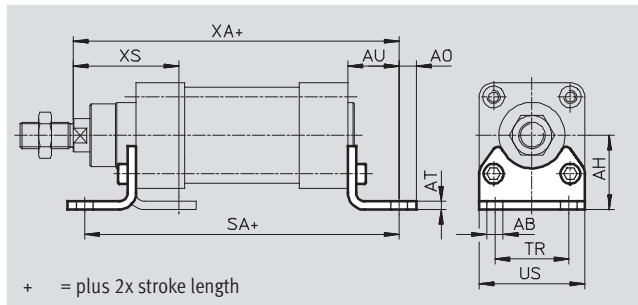

Dimensions and ordering data														
For Ø	AB	AH	AO	AT	AU	SA	TR	US	XA	XS	CRC ¹⁾	Weight	Part No.	Type
[mm]	Ø											[g]		
32	7	32	6.5	4	24	221.4	32	45	223.6	45	2	144	174 369	HNC-32
40	10	36	9	4	28	255.4	36	54	257.4	53	2	193	174 370	HNC-40
50	10	45	9.5	5	32	267.4	45	64	273.1	62	2	353	174 371	HNC-50
63	10	50	12.5	5	32	299.7	50	75	305.9	63	2	436	174 372	HNC-63
80	12	63	15	6	41	337.4	63	93	342.6	81	2	829	174 373	HNC-80
100	14.5	71	17.5	6	41	363.2	75	110	372.3	86	2	1 009	174 374	HNC-100
125	16.5	90	22	8	45	397	90	131	417.3	102	2	1 902	174 375	HNC-125

1) Corrosion resistance class 2 according to Festo standard 940 070
Components requiring moderate corrosion resistance. Externally visible parts with primarily decorative surface requirements which are in direct contact with a surrounding industrial atmosphere or media such as cooling or lubricating agents

Flange mounting FNC

Material:
Galvanised steel
Free of copper, PTFE and silicone

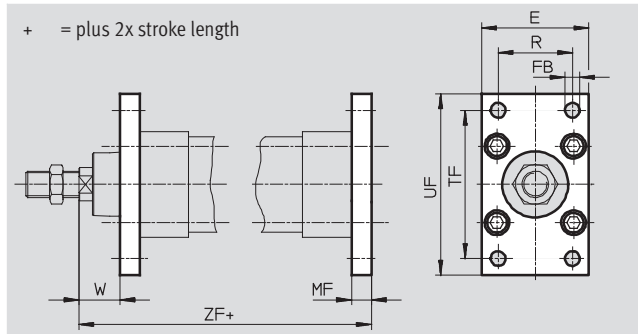

Dimensions and ordering data												
For Ø	E	FB	MF	R	TF	UF	W	ZF	CRC ¹⁾	Weight	Part No.	Type
[mm]		Ø H13								[g]		
32	45	7	10	32	64	80	16	209.6	2	240	174 376	FNC-32
40	54	9	10	36	72	90	20	239.4	2	280	174 377	FNC-40
50	65	9	12	45	90	110	25	253.1	2	520	174 378	FNC-50
63	75	9	12	50	100	120	25	285.9	2	690	174 379	FNC-63
80	93	12	16	63	126	150	30	317.6	2	1 650	174 380	FNC-80
100	110	14	16	75	150	175	35	347.3	2	2 400	174 381	FNC-100
125	132	16	20	90	180	210	45	392.3	2	3 750	174 382	FNC-125

1) Corrosion resistance class 2 according to Festo standard 940 070
Components requiring moderate corrosion resistance. Externally visible parts with primarily decorative surface requirements which are in direct contact with a surrounding industrial atmosphere or media such as cooling or lubricating agents

Tandem cylinders DNCT, standard port pattern

Accessories

Trunnion flange ZNCF

Material:
Corrosion resistant cast steel
Free of copper, PTFE and silicone

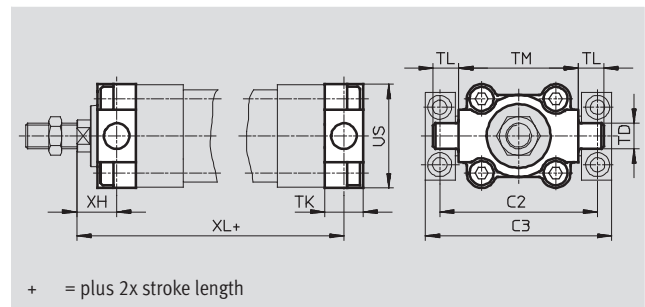

Dimensions and ordering data													
For Ø	C2	C3	TD	TK	TL	TM	US	XH	XL	CRC ¹⁾	Weight	Part No.	Type
[mm]			Ø e9								[g]		
32	71	86	12	16	12	50	45	18	207.6	2	150	174 411	ZNCF-32
40	87	105	16	20	16	63	54	20	239.4	2	285	174 412	ZNCF-40
50	99	117	16	24	16	75	64	25	253.1	2	473	174 413	ZNCF-50
63	116	136	20	24	20	90	75	25	285.9	2	687	174 414	ZNCF-63
80	136	156	20	28	20	110	93	32	315.6	2	1 296	174 415	ZNCF-80
100	164	189	25	38	25	132	110	32	350.3	2	2 254	174 416	ZNCF-100
125	192	217	25	50	25	160	131	40	397.3	2	3 484	174 417	ZNCF-125

1) Corrosion resistance class 2 according to Festo standard 940 070
Components requiring moderate corrosion resistance. Externally visible parts with primarily decorative surface requirements which are in direct contact with a surrounding industrial atmosphere or media such as cooling or lubricating agents

Tandem cylinders DNCT, standard port pattern

Accessories

Trunnion mounting kit ZNCM

The mounting kit can be attached at any position along the profile barrel of the cylinder.

Material:
Tempered steel

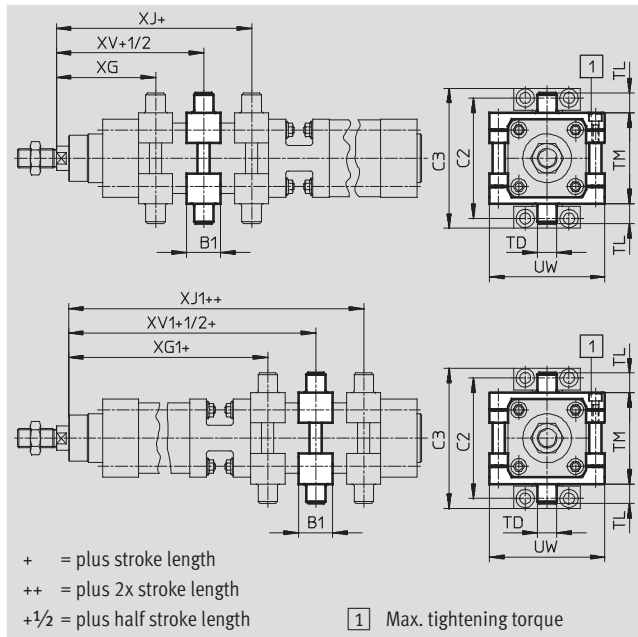

Dimensions and ordering data									
For \varnothing	B1	C2	C3	TD	TL	TM	UW	XG	XG1
[mm]				\varnothing e9					
32	30	71	86	12	12	50	65	66.3	145.4
40	32	87	105	16	16	63	75	75.6	169.5
50	34	99	117	16	16	75	95	84.3	181.4
63	41	116	136	20	20	90	105	94.3	208.8
80	44	136	156	20	20	110	130	104.1	229.9
100	48	164	189	25	25	132	145	112.9	252.2
125	50	192	217	25	25	160	175	135	278.8

For \varnothing	XJ	XJ1	XV	XV1	Max. tightening torque	CRC ¹⁾	Weight	Part No.	Type
[mm]					[Nm]		[g]		
32	80.4	159.5	73.4	152.5	4+1	2	210	163 525	ZNCM-32
40	89.9	183.8	82.8	176.7	8+1	2	385	163 526	ZNCM-40
50	97.4	194.5	90.9	188	8+2	2	595	163 527	ZNCM-50
63	103.4	217.8	98.9	213.3	18+2	2	890	163 528	ZNCM-63
80	117.9	243.7	111	236.8	28+2	2	1 450	163 529	ZNCM-80
100	129.2	268.5	121.1	260.4	28+2	2	2 045	163 530	ZNCM-100
125	158.8	302.6	146.9	290.7	40+2	2	2 940	163 531	ZNCM-125

1) Corrosion resistance class 2 according to Festo standard 940 070
Components requiring moderate corrosion resistance. Externally visible parts with primarily decorative surface requirements which are in direct contact with a surrounding industrial atmosphere or media such as cooling or lubricating agents

Tandem cylinders DNCT, standard port pattern

Accessories

Trunnion support LNZG

Material:
Trunnion support:
Anodised aluminium
Plain bearing: Plastic
Free of copper, PTFE and silicone

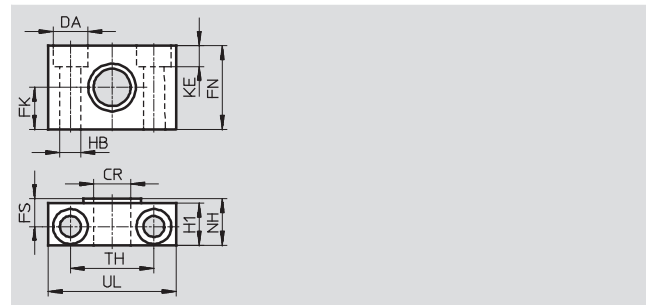
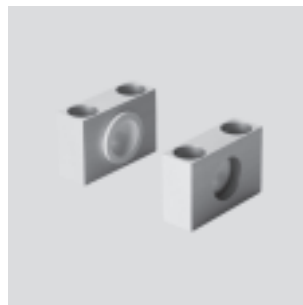

Dimensions and ordering data															
For \varnothing	CR	DA	FK	FN	FS	H1	HB	KE	NH	TH	UL	CRC ¹⁾	Weight	Part No.	Type
[mm]	\varnothing D11	\varnothing H13	\varnothing ± 0.1				\varnothing H13			± 0.2			[g]		
32	12	11	15	30	10.5	15	6.6	6.8	18	32	46	2	125	32 959	LNZG-32
40, 50	16	15	18	36	12	18	9	9	21	36	55	2	400	32 960	LNZG-40/50
63, 80	20	18	20	40	13	20	11	11	23	42	65	2	480	32 961	LNZG-63/80
100, 125	25	20	25	50	16	24.5	14	13	28.5	50	75	2	960	32 962	LNZG-100/125

1) Corrosion resistance class 2 according to Festo standard 940 070
Components requiring moderate corrosion resistance. Externally visible parts with primarily decorative surface requirements which are in direct contact with a surrounding industrial atmosphere or media such as cooling or lubricating agents

Swivel flange SNC

Material:
Die-cast aluminium

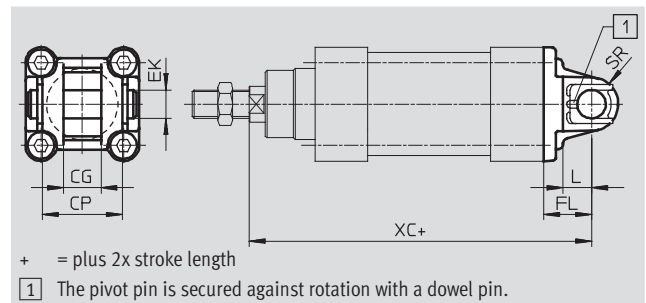

Dimensions and ordering data											
For \varnothing	CG	CP	EK	FL	L	SR	XC	CRC ¹⁾	Weight	Part No.	Type
[mm]	H14	h14	\varnothing h9	± 0.2					[g]		
32	14	34	10	22	13	10	221.6	2	90	174 383	SNC-32
40	16	40	12	25	16	12	254.4	2	120	174 384	SNC-40
50	21	45	16	27	16	12	268.1	2	240	174 385	SNC-50
63	21	51	16	32	21	16	305.9	2	320	174 386	SNC-63
80	25	65	20	36	22	16	337.6	2	625	174 387	SNC-80
100	25	75	20	41	27	20	372.3	2	830	174 388	SNC-100
125	37	97	30	50	30	25	422.3	2	1 785	174 389	SNC-125

1) Corrosion resistance class 2 according to Festo standard 940 070
Components requiring moderate corrosion resistance. Externally visible parts with primarily decorative surface requirements which are in direct contact with a surrounding industrial atmosphere or media such as cooling or lubricating agents

Tandem cylinders DNCT, standard port pattern

Accessories

Swivel flange SNCB

Material:
Die-cast aluminium
Free of copper, PTFE and silicone

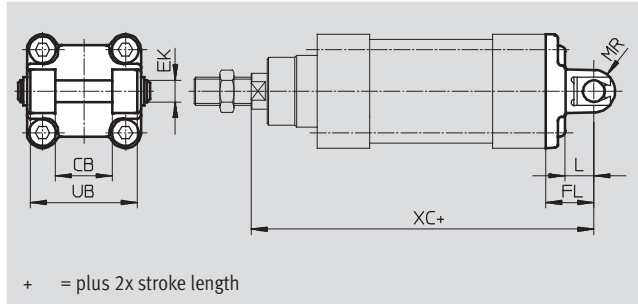

Dimensions and ordering data												
For Ø	CB	EK	FL	L	ML	MR	UB	XC	CRC ¹⁾	Weight	Part No.	Type
[mm]	H14	Ø e8	±0.2				h14			[g]		
32	26	10	22	13	55	8.5	45	221.6	2	100	174 390	SNCB-32
40	28	12	25	16	63	12	52	254.4	2	150	174 391	SNCB-40
50	32	12	27	16	71	12	60	268.1	2	225	174 392	SNCB-50
63	40	16	32	21	83	16	70	305.9	2	365	174 393	SNCB-63
80	50	16	36	22	103	16	90	337.6	2	610	174 394	SNCB-80
100	60	20	41	27	127	20	110	372.3	2	925	174 395	SNCB-100
125	70	25	50	30	148	25	130	422.3	2	1 785	174 396	SNCB-125

1) Corrosion resistance class 2 according to Festo standard 940 070
Components requiring moderate corrosion resistance. Externally visible parts with primarily decorative surface requirements which are in direct contact with a surrounding industrial atmosphere or media such as cooling or lubricating agents

Swivel flange SNCS

Material:
Die-cast aluminium

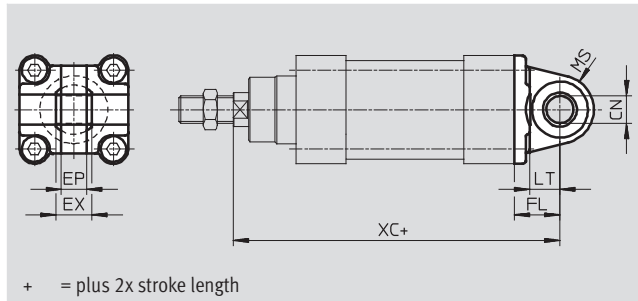
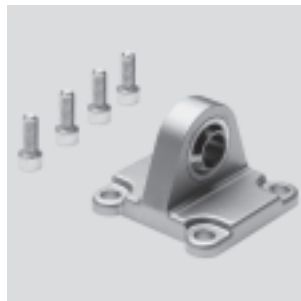

Dimensions and ordering data											
For Ø	CN	EP	EX	FL	LT	MS	XC	CRC ¹⁾	Weight	Part No.	Type
[mm]	Ø H7	±0.2		±0.2					[g]		
32	10	10.5	14	22	13	15	221.6	2	85	174 397	SNCS-32
40	12	12	16	25	16	17	254.4	2	125	174 398	SNCS-40
50	16	15	21	27	16	20	268.1	2	210	174 399	SNCS-50
63	16	15	21	32	21	22	305.9	2	280	174 400	SNCS-63
80	20	18	25	36	22	27	337.6	2	540	174 401	SNCS-80
100	20	18	25	41	27	29	372.3	2	700	174 402	SNCS-100
125	30	25	37	50	30	39	422.3	2	1 410	174 403	SNCS-125

1) Corrosion resistance class 2 according to Festo standard 940 070
Components requiring moderate corrosion resistance. Externally visible parts with primarily decorative surface requirements which are in direct contact with a surrounding industrial atmosphere or media such as cooling or lubricating agents

Tandem cylinders DNCT, standard port pattern

Accessories

Swivel flange SNCL

Material:
Die-cast aluminium
Free of copper, PTFE and silicone

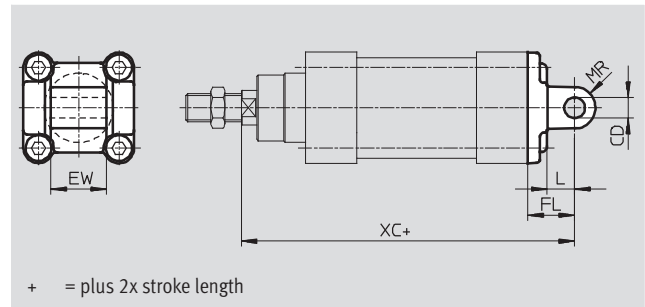
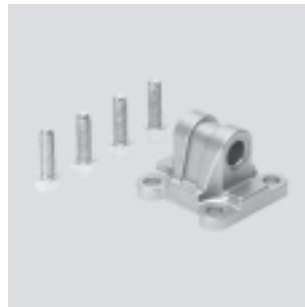

Dimensions and ordering data										
For \varnothing	CD	EW	FL	L	MR	XC	CRC ¹⁾	Weight	Part No.	Type
[mm]	\varnothing H9	-0.2/-0.6	± 0.2					[g]		
32	10	26	22	13	10	221.6	2	75	174 404	SNCL-32
40	12	28	25	16	12	254.4	2	100	174 405	SNCL-40
50	12	32	27	16	12	268.1	2	160	174 406	SNCL-50
63	16	40	32	21	16	305.9	2	250	174 407	SNCL-63
80	16	50	36	22	16	337.6	2	405	174 408	SNCL-80
100	20	60	41	27	20	372.3	2	655	174 409	SNCL-100
125	25	70	50	30	25	422.3	2	1 245	174 410	SNCL-125

1) Corrosion resistance class 2 according to Festo standard 940 070
Components requiring moderate corrosion resistance. Externally visible parts with primarily decorative surface requirements which are in direct contact with a surrounding industrial atmosphere or media such as cooling or lubricating agents

Tandem cylinders DNCT, standard port pattern

FESTO



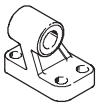
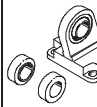
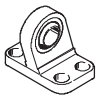
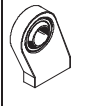
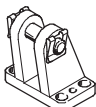
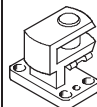

Accessories

Ordering data – Mounting attachments				Technical data → Internet: mounting attachment			
Designation	For Ø	Part No.	Type	Designation	For Ø	Part No.	Type
Clevis foot LNG				Clevis foot LSN			
	32	33 890	LNG-32		32	5 561	LSN-32
	40	33 891	LNG-40		40	5 562	LSN-40
	50	33 892	LNG-50		50	5 563	LSN-50
	63	33 893	LNG-63		63	5 564	LSN-63
	80	33 894	LNG-80		80	5 565	LSN-80
	100	33 895	LNG-100		100	5 566	LSN-100
	125	33 896	LNG-125		125	6 987	LSN-125
Clevis foot LSNG				Clevis foot LSNSG			
	32	31 740	LSNG-32		32	31 747	LSNSG-32
	40	31 741	LSNG-40		40	31 748	LSNSG-40
	50	31 742	LSNG-50		50	31 749	LSNSG-50
	63	31 743	LSNG-63		63	31 750	LSNSG-63
	80	31 744	LSNG-80		80	31 751	LSNSG-80
	100	31 745	LSNG-100		100	31 752	LSNSG-100
	125	31 746	LSNG-125		125	31 753	LSNSG-125
Clevis foot LBG				Right-angle clevis foot LQG			
	32	31 761	LBG-32		32	31 768	LQG-32
	40	31 762	LBG-40		40	31 769	LQG-40
	50	31 763	LBG-50		50	31 770	LQG-50
	63	31 764	LBG-63		63	31 771	LQG-63
	80	31 765	LBG-80		80	31 772	LQG-80
	100	31 766	LBG-100		100	31 773	LQG-100
	125	31 767	LBG-125		125	31 774	LQG-125

Tandem cylinders DNCT, standard port pattern

Accessories

FESTO

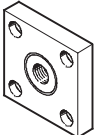
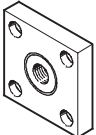
Ordering data – Piston rod attachments				Technical data → Internet: piston rod attachment			
Designation	For Ø	Part No.	Type	Designation	For Ø	Part No.	Type
Rod eye SGS				Rod clevis SGA			
	32	9 261	SGS-M10x1,25		32	32 954	SGA-M10x1,25
	40	9 262	SGS-M12x1,25		40	10 767	SGA-M12x1,25
	50	9 263	SGS-M16x1,5		50	10 768	SGA-M16x1,5
	63						
	80	9 264	SGS-M20x1,5		80	10 769	SGA-M20x1,5
	100	10 774	SGS-M27x2		100	10 770	SGA-M27x2
	125						
Rod clevis SG				Self-aligning rod coupler FK			
	32	6 144	SG-M10x1,25		32	6 140	FK-M10x1,25
	40	6 145	SG-M12x1,25		40	6 141	FK-M12x1,25
	50	6 146	SG-M16x1,5		50	6 142	FK-M16x1,5
	63						
	80	6 147	SG-M20x1,5		80	6 143	FK-M20x1,5 ¹⁾
	100	14 987	SG-M27x2-B		100	10 485	FK-M27x2
	125						
Coupling piece KSG				 <p>- Note</p> <p>¹⁾ If these piston-rod attachments are used, the maximum force of 10,000 N must not be exceeded.</p>			
	32	32 963	KSG-M10x1,25				
	40	32 964	KSG-M12x1,25				
	50	32 965	KSG-M16x1,5				
	63						
	80	32 966	KSG-M20x1,5				
	100	32 967	KSG-M27x2				
	125						

Ordering data – One-way flow control valves				Technical data → Internet: grla	
	Connection		Material	Part No.	Type
	Thread	For tubing O.D.			
	G ¹ / ₈	3	Metal design	193 142	GRLA- ¹ / ₈ -QS-3-D
		4		193 143	GRLA- ¹ / ₈ -QS-4-D
		6		193 144	GRLA- ¹ / ₈ -QS-6-D
		8		193 145	GRLA- ¹ / ₈ -QS-8-D
	G ¹ / ₄	6		193 146	GRLA- ¹ / ₄ -QS-6-D
		8		193 147	GRLA- ¹ / ₄ -QS-8-D
		10		193 148	GRLA- ¹ / ₄ -QS-10-D
	G ³ / ₈	6		193 149	GRLA- ³ / ₈ -QS-6-D
		8		193 150	GRLA- ³ / ₈ -QS-8-D
		10		193 151	GRLA- ³ / ₈ -QS-10-D
	G ¹ / ₂	12		193 152	GRLA- ¹ / ₂ -QS-12-D

Tandem cylinders DNCT, standard port pattern

Accessories

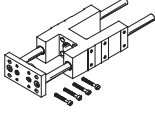

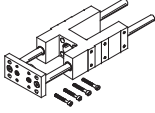
Ordering data – Guide units for fixed strokes (recirculating ball bearing guide only)				Technical data → Internet: feng		
	Stroke [mm]	Part No.	Type	Stroke [mm]	Part No.	Type
	For Ø 32 mm			For Ø 40 mm		
	10 ... 50	34 493	FENG-32-50-KF	10 ... 50	34 499	FENG-40-50-KF
	10 ... 100	34 494	FENG-32-100-KF	10 ... 100	34 500	FENG-40-100-KF
	10 ... 160	34 495	FENG-32-160-KF	10 ... 160	34 501	FENG-40-160-KF
	10 ... 200	34 496	FENG-32-200-KF	10 ... 200	34 502	FENG-40-200-KF
	10 ... 250	150 289	FENG-32-250-KF	10 ... 250	34 503	FENG-40-250-KF
	10 ... 320	34 497	FENG-32-320-KF	10 ... 320	34 504	FENG-40-320-KF
	10 ... 400	150 290	FENG-32-400-KF	10 ... 400	150 291	FENG-40-400-KF
	10 ... 500	34 498	FENG-32-500-KF	10 ... 500	34 505	FENG-40-500-KF
	For Ø 50 mm			For Ø 63 mm		
	10 ... 50	34 506	FENG-50-50-KF	10 ... 50	34 513	FENG-63-50-KF
	10 ... 100	34 507	FENG-50-100-KF	10 ... 100	34 514	FENG-63-100-KF
	10 ... 160	34 508	FENG-50-160-KF	10 ... 160	34 515	FENG-63-160-KF
	10 ... 200	34 509	FENG-50-200-KF	10 ... 200	34 516	FENG-63-200-KF
	10 ... 250	34 510	FENG-50-250-KF	10 ... 250	34 517	FENG-63-250-KF
	10 ... 320	34 511	FENG-50-320-KF	10 ... 320	34 518	FENG-63-320-KF
	10 ... 400	150 292	FENG-50-400-KF	10 ... 400	34 519	FENG-63-400-KF
	10 ... 500	34 512	FENG-50-500-KF	10 ... 500	34 520	FENG-63-500-KF
	For Ø 80 mm			For Ø 100 mm		
	10 ... 50	34 521	FENG-80-50-KF	10 ... 50	34 529	FENG-100-50-KF
	10 ... 100	34 522	FENG-80-100-KF	10 ... 100	34 530	FENG-100-100-KF
	10 ... 160	34 523	FENG-80-160-KF	10 ... 160	34 531	FENG-100-160-KF
	10 ... 200	34 524	FENG-80-200-KF	10 ... 200	34 532	FENG-100-200-KF
	10 ... 250	34 525	FENG-80-250-KF	10 ... 250	34 533	FENG-100-250-KF
	10 ... 320	34 526	FENG-80-320-KF	10 ... 320	34 534	FENG-100-320-KF
	10 ... 400	34 527	FENG-80-400-KF	10 ... 400	34 535	FENG-100-400-KF
	10 ... 500	34 528	FENG-80-500-KF	10 ... 500	34 536	FENG-100-500-KF

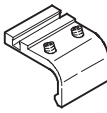

Ordering data – Guide units for variable strokes				Technical data → Internet: feng		
	For Ø [mm]	Stroke [mm]	With recirculating ball bearing guide Part No. Type	With plain bearing guide Part No. Type		
	32	10 ... 500	34 487 FENG-32-...-KF	34 481	FENG-32-...	
	40	10 ... 500	34 488 FENG-40-...-KF	34 482	FENG-40-...	
	50	10 ... 500	34 489 FENG-50-...-KF	34 483	FENG-50-...	
	63	10 ... 500	34 490 FENG-63-...-KF	34 484	FENG-63-...	
	80	10 ... 500	34 491 FENG-80-...-KF	34 485	FENG-80-...	
	100	10 ... 500	34 492 FENG-100-...-KF	34 486	FENG-100-...	

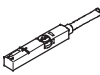

Ordering data – Mounting kits for proximity sensors SMT-8		Technical data → Internet: smb	
	For Ø [mm]	Part No.	Type
	32	175 705	SMB-8-FENG-32/40
	40		
	50	175 706	SMB-8-FENG-50/63
	63		
	80	175 707	SMB-8-FENG-80/100
100			

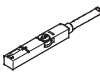
Tandem cylinders DNCT, standard port pattern

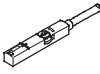
Accessories

Ordering data – Proximity sensors for T-slot, magneto-resistive					Technical data → Internet: smt	
	Type of mounting	Switch output	Electrical connection	Cable length [m]	Part No.	Type
N/O contact						
	Insertable in the slot from above, flush with cylinder profile	PNP	Cable, 3-wire	2.5	543 867	SMT-8M-PS-24V-K-2,5-OE
			Plug M8x1, 3-pin	0.3	543 866	SMT-8M-PS-24V-K-0,3-M8D
			Plug M12x1, 3-pin	0.3	543 869	SMT-8M-PS-24V-K-0,3-M12
	Insertable in the slot lengthwise, flush with the cylinder profile	PNP	Cable, 3-wire	2.5	543 870	SMT-8M-NS-24V-K-2,5-OE
			Plug M8x1, 3-pin	0.3	543 871	SMT-8M-NS-24V-K-0,3-M8D
N/C contact						
	Insertable in the slot from above, flush with cylinder profile	PNP	Cable, 3-wire	7.5	543 873	SMT-8M-PO-24V-K7,5-OE

Ordering data – Proximity sensors for T-slot, magnetic reed					Technical data → Internet: sme	
	Type of mounting	Switch output	Electrical connection	Cable length [m]	Part No.	Type
N/O contact						
	Insertable in the slot from above, flush with cylinder profile	Contacting	Cable, 3-wire	2.5	543 862	SME-8M-DS-24V-K-2,5-OE
				5.0	543 863	SME-8M-DS-24V-K-5,0-OE
			Plug M8x1, 3-pin	0.3	543 861	SME-8M-DS-24V-K-0,3-M8D
	Insertable in the slot lengthwise, flush with the cylinder profile	Contacting	Cable, 3-wire	2.5	150 855	SME-8-K-LED-24
			Plug M8x1, 3-pin	0.3	150 857	SME-8-S-LED-24
N/C contact						
	Insertable in the slot lengthwise, flush with the cylinder profile	Contacting	Cable, 3-wire	7.5	160 251	SME-8-0-K-LED-24

Ordering data – Connecting cables				Technical data → Internet: nebu	
	Electrical connection, left	Electrical connection, right	Cable length [m]	Part No.	Type
	Straight socket, M8x1, 3-pin	Cable, open end, 3-wire	2.5	541 333	NEBU-M8G3-K-2.5-LE3
			5	541 334	NEBU-M8G3-K-5-LE3
	Straight socket, M12x1, 5-pin	Cable, open end, 3-wire	2.5	541 363	NEBU-M12G5-K-2.5-LE3
			5	541 364	NEBU-M12G5-K-5-LE3
	Angled socket, M8x1, 3-pin	Cable, open end, 3-wire	2.5	541 338	NEBU-M8W3-K-2.5-LE3
			5	541 341	NEBU-M8W3-K-5-LE3
	Angled socket, M12x1, 5-pin	Cable, open end, 3-wire	2.5	541 367	NEBU-M12W5-K-2.5-LE3
			5	541 370	NEBU-M12W5-K-5-LE3

Ordering data – Slot cover for T-slot			Part No.	Type
Mounting	Length			
	Insertable from above	2x 0.5 m	151 680	ABP-5-S

High-force cylinders ADNH, standard port pattern

Peripherals overview

FESTO

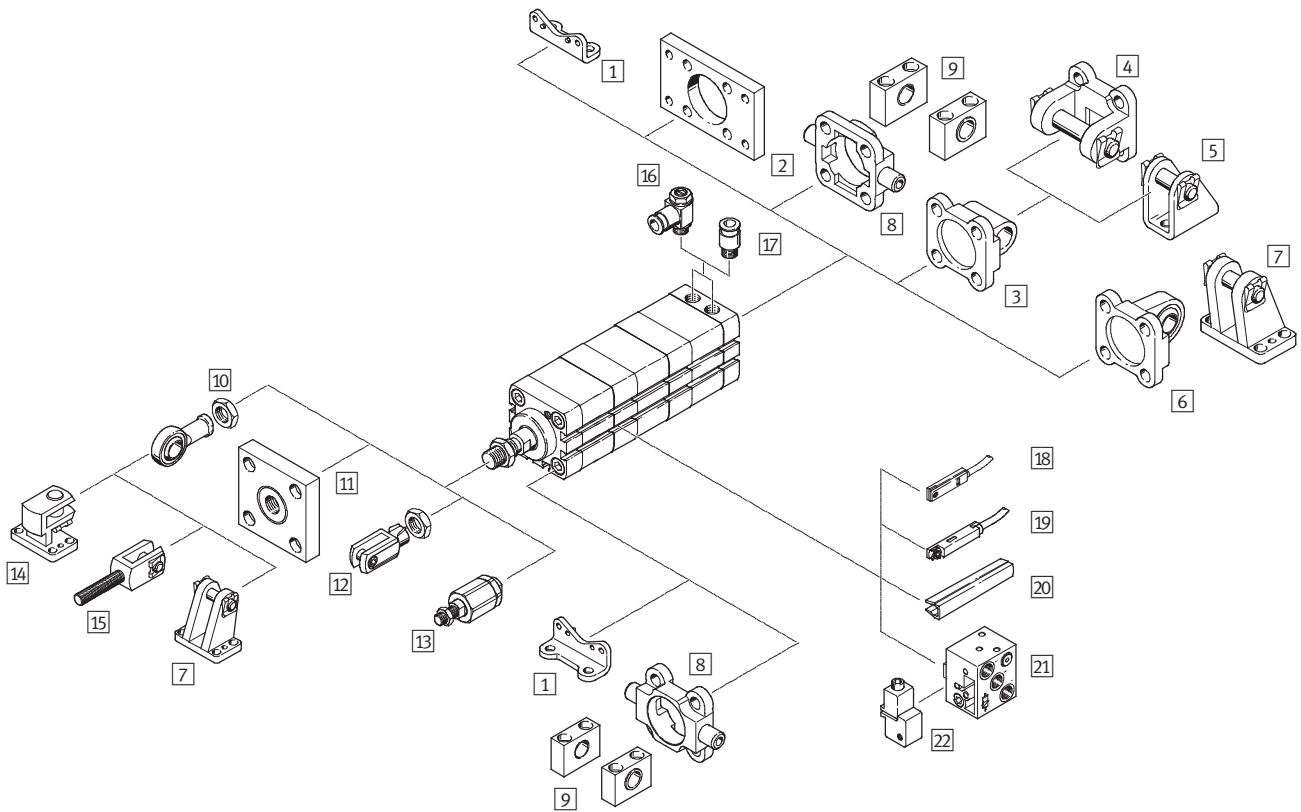

High-force cylinders ADNH, standard port pattern

Peripherals overview

Mounting attachments and accessories					
	Brief description	∅ 25	∅ 40, 63, 100	→ Page/Internet	
1	Foot mounting HNA	For bearing and end caps	■	■	30
2	Flange mounting FNC	For end caps	■	■	31
3	Swivel flange SNCL	For end caps	■	■	32
4	Swivel flange SNCB	For swivel flange SNCL	-	■	34
5	Clevis foot LBN/CRLBN	For swivel flange SNCL	■	-	33
6	Swivel flange SNCS	For end caps	-	■	32
7	Clevis foot LBG	For swivel flange SNCS	-	■	36
8	Trunnion flange ZNCF/CRZNG	For end caps	-	■	35
9	Trunnion support LNZG	For trunnion flange ZNCF/CRZNG	-	■	35
10	Rod eye SGS/CRSGS	With spherical bearing	■	■	36
11	Coupling piece KSG	For compensating radial deviations	■	■	36
12	Rod clevis SG/CRSG	Permits a swivelling movement of the cylinder in one plane	■	■	36
13	Self-aligning rod coupler FK	For compensating radial and angular deviations	■	■	36
14	Right-angle clevis foot LQG	For rod eye SGS	-	■	36
15	Rod clevis SGA	With male thread	-	■	36
16	One-way flow control valve GRLA	For speed regulation	■	■	36
17	Push-in fitting QS	For connecting compressed air tubing with standard external diameters	■	■	quick star
18	Proximity sensor SME/SMT-8	Can be integrated in the sensor slot of the cylinder profile barrel	■	■	37
19	Proximity sensor SME/SMT-8M	Can be integrated in the sensor slot of the cylinder profile barrel	■	■	37
20	Slot cover ABP-5-S	For protecting the sensor cable and keeping dirt out of the sensor slots	■	■	38
21	Proximity sensor SMPO-8E	Pneumatic output signal	■	■	38
22	Mounting kit SMB-8E	For proximity sensor SMPO-8E	■	■	38

High-force cylinders ADNH, standard port pattern

Type codes

ADNH - 40 - 80 - A - P - A - 2N - K2

Type

Double-acting	
ADNH	High-force cylinder

Piston Ø [mm]

Stroke [mm]

Piston rod thread

A	Male thread
I	Female thread

Cushioning

P	Flexible cushioning rings/pads at both ends
---	---

Position sensing

A	Via proximity sensor
---	----------------------

Number of cylinders

2N	2 cylinders for twice the force
3N	3 cylinders for three times the force
4N	4 cylinders for four times the force

Variant

K2	Extended male piston rod thread
K5	Special piston rod thread
K8	Extended piston rod
S6	Heat-resistant seals up to max. 120 °C
TL	Captive rating plate (laser etched)

High-force cylinders ADNH, standard port pattern

Technical data

Function

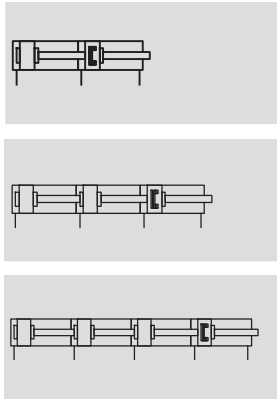

Variants

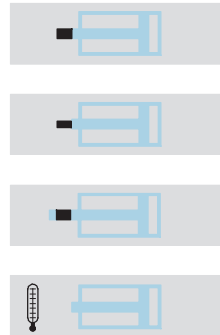

K2

K5

K8

S6

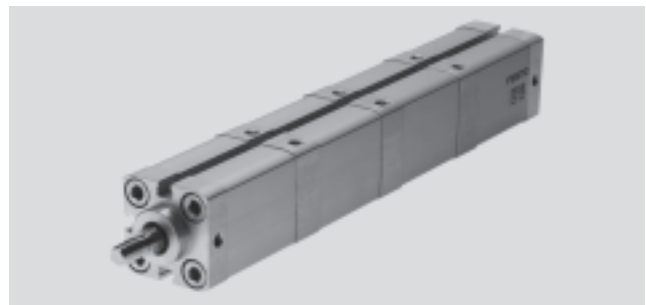

- - Diameter
25 ... 100 mm
- - Stroke length
1 ... 150 mm

General technical data					
Piston Ø		25	40	63	100
Pneumatic connection		M5	M5	G1/8	G1/8
Piston rod thread	Female	M6	M10	M12	M16
	Male	M8	M12x1.25	M16x1.5	M20x1.5
Constructional design		Piston			
		Piston rod			
		Cylinder barrel			
Cushioning		Flexible cushioning rings/pads at both ends			
Position sensing		Via proximity sensor			
Type of mounting		Via female threads			
		Via accessories			
Mounting position		Any			

Operating and environmental conditions					
Piston Ø		25	40	63	100
Operating medium		Filtered compressed air, lubricated or unlubricated			
Operating pressure [bar]	2 cylinders	0.8 ... 10		0.6 ... 10	
	3 cylinders	1.1 ... 10		0.9 ... 10	
	4 cylinders	1.4 ... 10		1.2 ... 10	
Ambient temperature ¹⁾ [°C]		-20 ... +80			
	S6	0 ... +120			
Corrosion resistance class CRC ²⁾		2			

1) Note operating range of proximity sensors
 2) Corrosion resistance class 2 to Festo standard 940 070
 Components subject to moderate corrosion stress. Externally visible parts with primarily decorative surface requirements which are in direct contact with a normal industrial environment or media such as coolants or lubricating agents

High-force cylinders ADNH, standard port pattern

Technical data

Forces [N] and impact energy [J]					
Piston \varnothing		25	40	63	100
Theoretical force at 6 bar, advancing	2 cylinders	542	1440	3619	9235
	3 cylinders	789	2126	5369	13758
	4 cylinders	1036	2812	7120	18281
Theoretical force at 6 bar, retracting ¹⁾		247	633	1681	4417
Max. impact energy at the end positions		0.3	0.7	1.3	2.5
	S6	0.15	0.35	0.65	1.25

1) During retraction only the force of one cylinder is available

Max. lateral force F_q as a function of the projection x

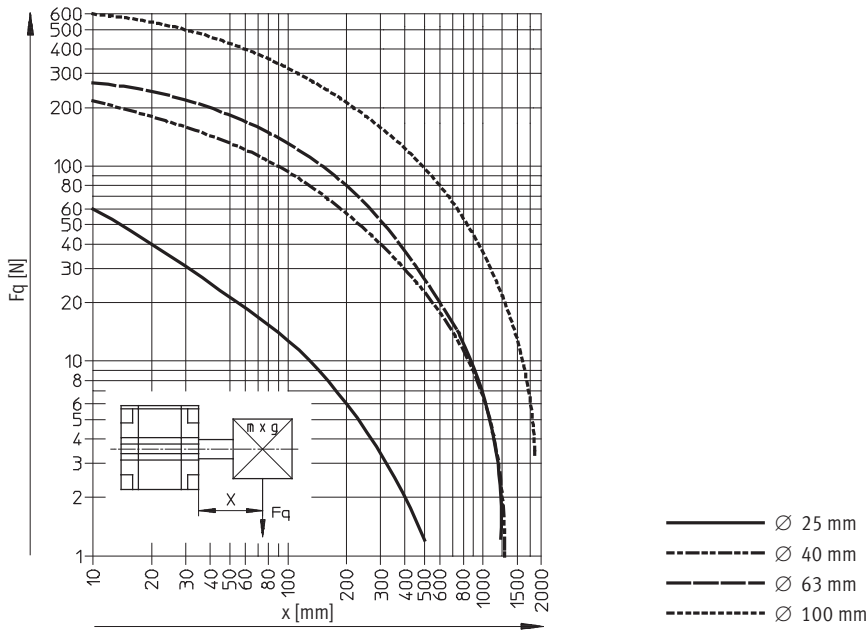

High-force cylinders ADNH, standard port pattern

Technical data

Materials

Sectional view

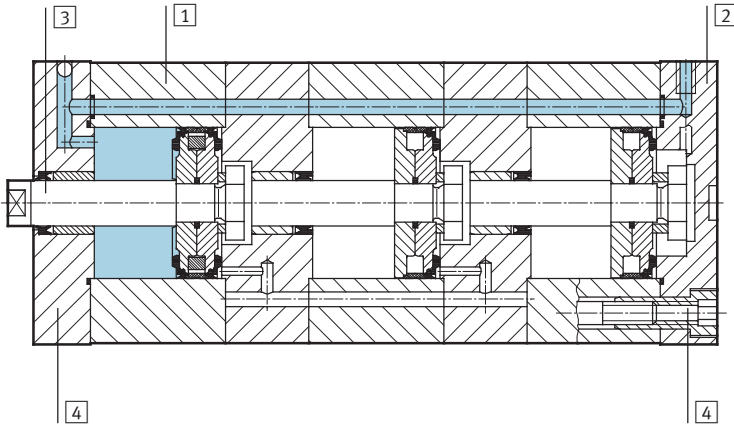

High-force cylinder	Basic version	S6
1 Cylinder barrel	Anodised aluminium	Anodised aluminium
2 Cover	Anodised aluminium	Anodised aluminium
3 Piston rod	High-alloy steel	High-alloy steel
4 Flange screws	Galvanised steel	Galvanised steel
- Seals	Polyurethane, nitrile rubber	Fluoro elastomer
Notes on materials	RoHS compliant	

High-force cylinders ADNH, standard port pattern

Technical data



Dimensions – Basic version

Download CAD data → www.festo.com

∅ 25/2N – 2 cylinders

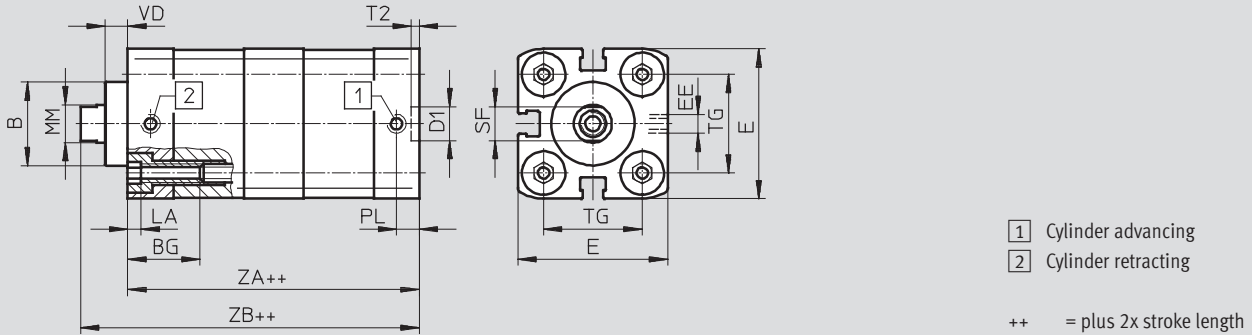

∅ 40 ... 100/2N – 2 cylinders

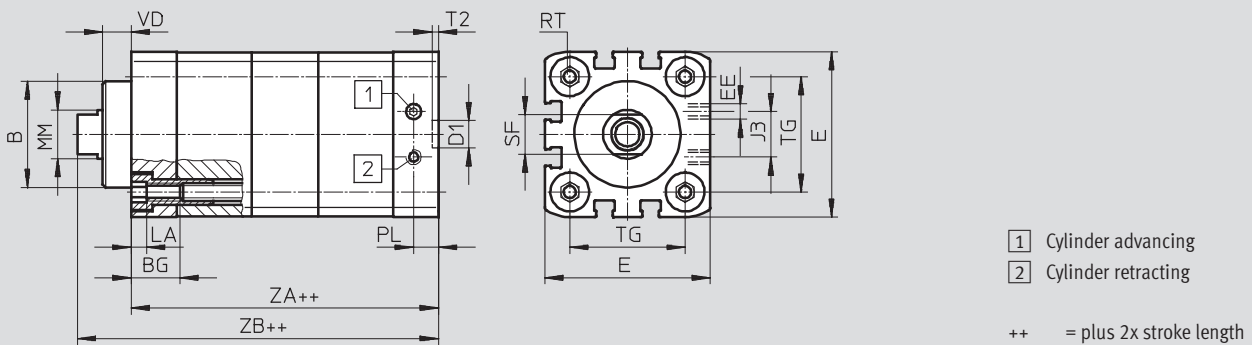

3N – 3 cylinders

4N – 4 cylinders

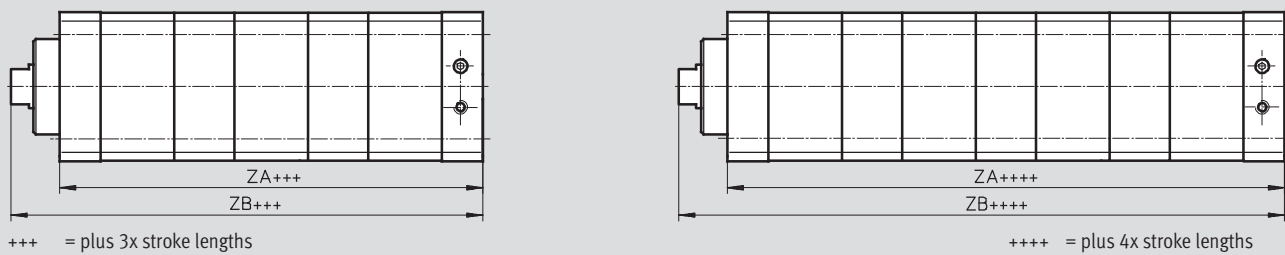

∅	B	BG	D1	E	EE	J3	LA	MM	PL	RT
[mm]	∅ f8	min.	∅ H9	+0.3			+0.2	∅ h9	+0.2	
25	22	15	9	39.5	M5	–	5	10	6	M5
40	35	12		54.5		15		16	8.2	M6
63	42		75.5	23	20	M8				
100	55	17	113.5	40	25	10.5		M10		

∅	SF	T2	TG	VD	ZA			ZB		
					Number of cylinders			Number of cylinders		
[mm]		+0.1	±0.2		2	3	4	2	3	4
25	9	2.1	26	6	76.3 ^{+1.2}	110.5 ^{+1.8}	144.7 ^{+2.4}	88.5 ^{+1.6}	122.7 ^{+2.2}	156.9 ^{+2.8}
40	13		38	9.5	86.2 ^{+1.2}	125.5 ^{+1.8}	164.8 ^{+2.4}	104.6 ^{+1.6}	143.9 ^{+2.2}	183.2 ^{+2.8}
63	17	2.6	56.5	12	93.3 ^{+1.2}	135.7 ^{+1.8}	178.1 ^{+2.4}	114.6 ^{+1.6}	157 ^{+2.2}	199.4 ^{+2.8}
100	21		89	15.5	120.9 ^{+1.2}	172.8 ^{+1.8}	224.7 ^{+2.4}	147.9 ^{+1.6}	199.8 ^{+2.2}	251.7 ^{+2.8}

High-force cylinders ADNH, standard port pattern

Technical data

Dimensions – Variants Download CAD data → www.festo.com

Basic version

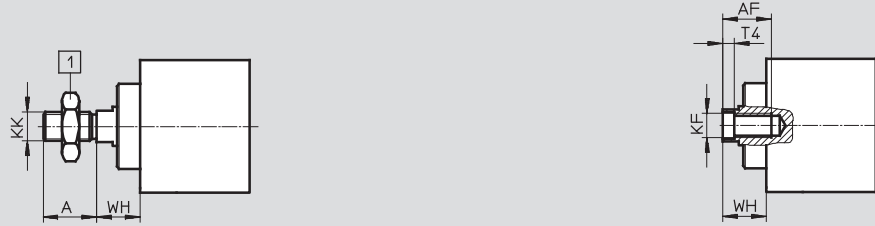

1 Hex nut to DIN 439-B only with \varnothing 40 ... 100

K2 – Extended male piston rod thread

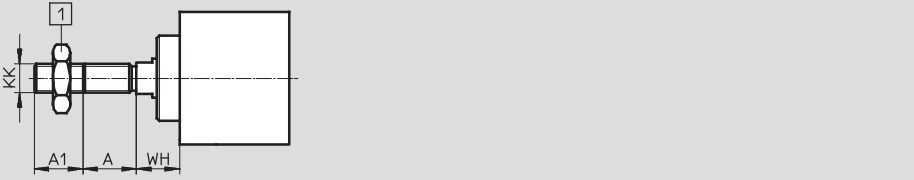

1 Hex nut to DIN 439-B only with \varnothing 40 ... 100

K5 – Special piston rod thread

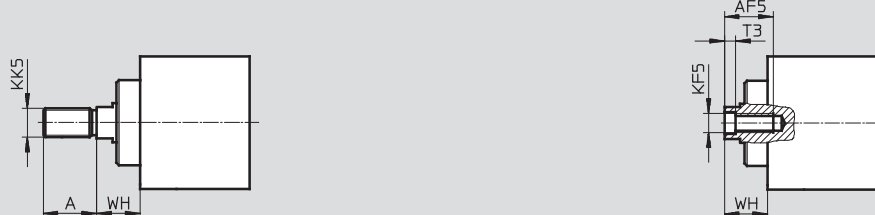

K8 – Extended piston rod

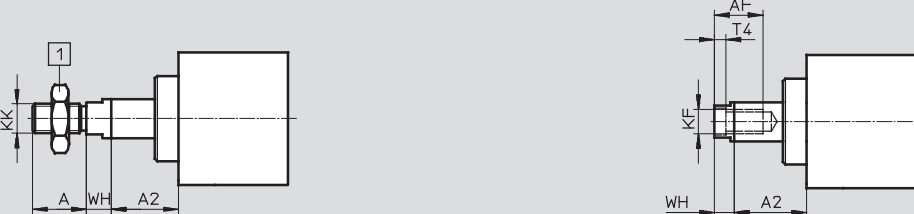

1 Hex nut to DIN 439-B only with \varnothing 40 ... 100

\varnothing	A	A1	A2	AF	AF5	KF	KF5	KK	KK5	T3	T4	WH
[mm]	-0.5			min.	min.							+1.3
25	16	1 ... 20	1 ... 150	14	12	M6	M5	M8	M10x1.25 M10	2	2.6	11.8
40	22			20	16	M10	M8	M12x1.25	M10x1.25 M12	3.3	4.7	18
63	28			20	20	M12	M10	M16x1.5	M12x1.25 M16	4.7	6.1	21
100	40	1 ... 30		25	-	M16	-	M20x1.5	M16x1.5 M20	-	7	26.5

High-force cylinders ADNH, standard port pattern

Ordering data – Modular products

M Mandatory data →

Module No.	Function	Size	Stroke	Type of thread	Cushioning	Position sensing	Number of cylinders
539 691	ADNH	25	1 ... 150	A	P	A	2N
539 692		40		I			3N
539 693		63					4N
539 694		100					
Order example							
539 694	ADNH	- 100	- 120	- A	- P	- A	- 4N

Ordering table

Size	25	40	63	100	Condi- tions	Code	Enter code
M Module No.	539 691	539 692	539 693	539 694			
Function	Compact tandem cylinder, based on ISO 21287					ADNH	ADNH
Size [mm]	25	40	63	100		-...	
Stroke [mm]	1 ... 150					-...	
Type of thread	Male thread					-A	
	Female thread					-I	
Cushioning	Flexible cushioning rings/pads at both ends					-P	-P
Position sensing	Via proximity sensor					-A	-A
Number of cylinders	2 cylinders for twice the force					-2N	- ... N
	3 cylinders for three times the force					-3N	
	4 cylinders for four times the force					-4N	

Transfer order code

	ADNH	-		-		-	P	-	A	-	...N
--	-------------	---	--	---	--	---	----------	---	----------	---	-------------

High-force cylinders ADNH, standard port pattern

Ordering data – Modular products

Options				
Male thread extended	Special thread	Piston rod extended	Temperature resistance	Captive rating plate
...K2	"..."K5	...K8	S6	TL
- 25K2	- "M16x1.5"K5	-	- S6	-

Ordering table							
Size	25	40	63	100	Condi- tions	Code	Enter code
Male thread extended [mm]	Extended male piston rod thread					-...K2	
Special piston rod thread	M10x1.25	M10x1.25	M12x1.25	M16x1.5	[1]	-"..."K5	
	M5	M8	M10	-	[2]		
Piston rod extended [mm]	Extended piston rod					-...K8	
Temperature resistance	Heat-resistant seals up to max. 120 °C					-S6	
Captive rating plate	Laser etched rating plate					-TL	

- [1] K5 Only with piston rod thread A (male thread)
- [2] K5 Only with piston rod thread I (female thread)

- [3] K8 The sum of the stroke length and piston rod extension must not exceed the maximum permissible stroke length

Transfer order code

- - - - -

High-force cylinders ADNH, standard port pattern

Accessories

Foot mounting HNA

Material:

HNA: Galvanised steel

HNA-...-R3: Steel with protective coating

Free of copper, PTFE and silicone

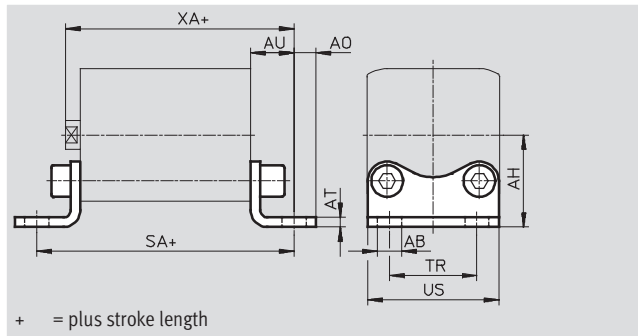

Dimensions and ordering data									
For \varnothing	AB \varnothing	AH	A0	AT	AU	SA	TR	US	XA
[mm]	H14	JS14		± 0.5	± 0.2		± 0.2	-0.5	
25	7	29	6.25	4	16	71	26	38.5	61
40	10	38	9		18	81	36	54	69
63		50	8	5	21	91	50	75	78
100	14.5	74	12.5	6	27	121	75	110	103

For \varnothing	Basic version				R3 – High corrosion protection			
	CRC ¹⁾	Weight [g]	Part No.	Type	CRC ¹⁾	Weight [g]	Part No.	Type
[mm]								
25	2	55	537 240	HNA-25	3	55	537 255	HNA-25-R3
40	2	90	537 242	HNA-40	3	90	537 257	HNA-40-R3
63	2	180	537 244	HNA-63	3	180	537 259	HNA-63-R3
100	2	470	537 250	HNA-100	3	470	537 261	HNA-100-R3

1) Corrosion resistance class 2 to Festo standard 940 070

Components subject to moderate corrosion stress. Externally visible parts with primarily decorative surface requirements which are in direct contact with a normal industrial environment or media such as coolants or lubricating agents.

Corrosion resistance class 3 to Festo standard 940 070

Components requiring higher corrosion resistance. External visible parts in direct contact with industrial atmospheres or media such as solvents and cleaning agents, with a predominantly functional requirement for the surface

High-force cylinders ADNH, standard port pattern

Accessories

Flange mounting FNC

Material:
Galvanised steel
Free of copper, PTFE and silicone

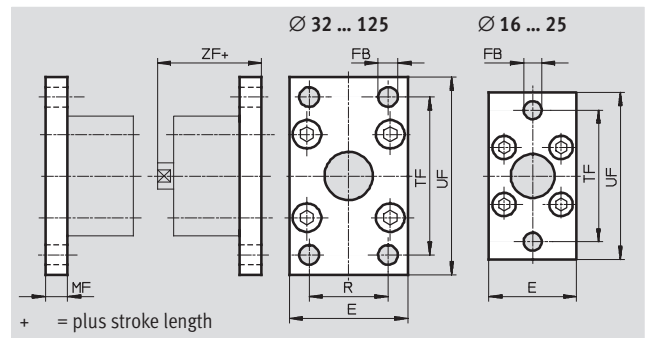

Dimensions and ordering data											
For Ø	E	FB Ø	MF	R	TF	UF ±1	ZF	CRC ¹⁾	Weight [g]	Part No.	Type
25	40	6.6	8	-	60	76	53	2	-	537 248	FNC-25
40	54	9	10	36	72	90	61	2	280	174 377	FNC-40
63	75		12	50	100	120	69	2	690	174 379	FNC-63
100	110	14	16	75	150	175	92	2	2400	174 381	FNC-100

1) Corrosion resistance class 2 to Festo standard 940 070
Components subject to moderate corrosion stress. Externally visible parts with primarily decorative surface requirements which are in direct contact with a normal industrial environment or media such as coolants or lubricating agents

High-force cylinders ADNH, standard port pattern

Accessories



Swivel flange SNCL

Material:
 SNCL: Die-cast aluminium
 SNCL-...-R3: Die-cast aluminium with protective coating
 Free of copper, PTFE and silicone

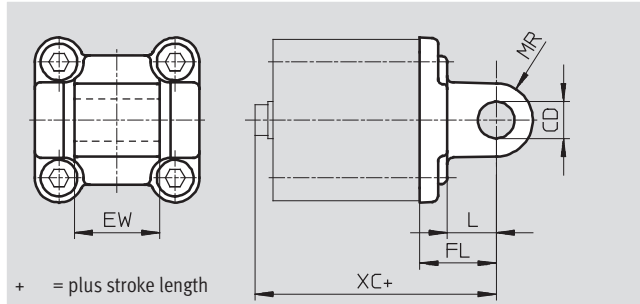
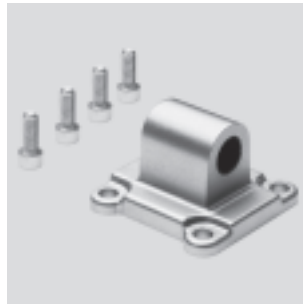

Dimensions and ordering data						
For \varnothing	CD	EW	FL	L	MR	XC
[mm]	\varnothing H9		± 0.2			
25	8	16 _{h12}	20	14	8	65
40	12	28 _{-0.2/-0.6}	25	16	12	76
63	16	40 _{-0.2/-0.6}	32	21	16	89
100	20	60 _{-0.2/-0.6}	41	27	20	117

For \varnothing	Basic version				R3 – High corrosion protection			
	CRC ¹⁾	Weight [g]	Part No.	Type	CRC ¹⁾	Weight [g]	Part No.	Type
[mm]								
25	2	45	537 793	SNCL-25	3	45	537 797	SNCL-25-R3
40	2	115	174 405	SNCL-40	–	–	–	–
63	2	270	174 407	SNCL-63	–	–	–	–
100	2	700	174 409	SNCL-100	–	–	–	–

- 1) Corrosion resistance class 2 to Festo standard 940 070
 Components subject to moderate corrosion stress. Externally visible parts with primarily decorative surface requirements which are in direct contact with a normal industrial environment or media such as coolants or lubricating agents.
 Corrosion resistance class 3 to Festo standard 940 070
 Components requiring higher corrosion resistance. External visible parts in direct contact with industrial atmospheres or media such as solvents and cleaning agents, with a predominantly functional requirement for the surface

Swivel flange SNCS

Material:
 Die-cast aluminium

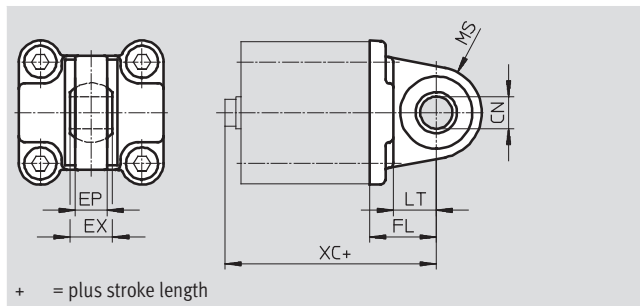
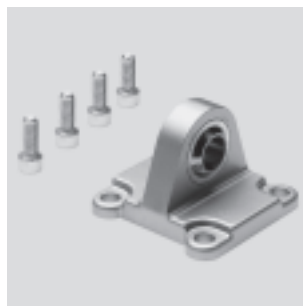

Dimensions and ordering data											
For \varnothing	CN	EP	EX	FL	LT	MS	XC	CRC ¹⁾	Weight	Part No.	Type
[mm]	\varnothing H7	± 0.2		± 0.2					[g]		
40	12	12	16	25	16	17	70	2	125	174 398	SNCS-40
63	16	15	21	32	21	22	81	2	280	174 400	SNCS-63
100	20	18	25	41	27	29	108	2	700	174 402	SNCS-100

- 1) Corrosion resistance class 2 to Festo standard 940 070
 Components subject to moderate corrosion stress. Externally visible parts with primarily decorative surface requirements which are in direct contact with a normal industrial environment or media such as coolants or lubricating agents

High-force cylinders ADNH, standard port pattern

Accessories

Clevis foot LBN

Material:
Galvanised steel
Free of copper, PTFE and silicone

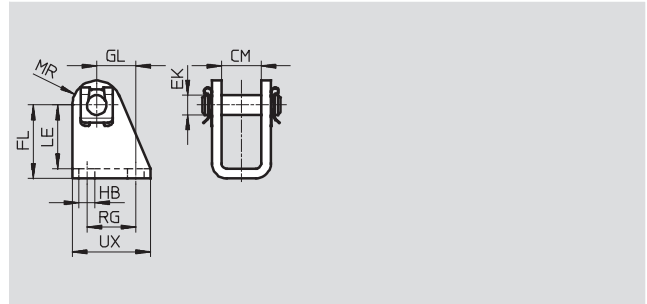
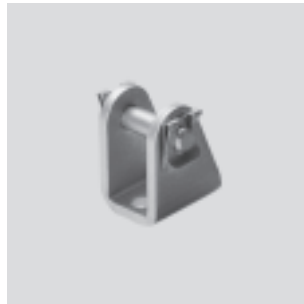

Dimensions and ordering data													
For \varnothing	CM	EK	FL	GL	HB	LE	MR	RG	UX	CRC ¹⁾	Weight	Part No.	Type
[mm]		\varnothing			\varnothing						[g]		
25	16.1	8	30 +0.4/-0.2	16	6.6	26	10	20	32	2	81	6 059	LBN-20/25

1) Corrosion resistance class 2 to Festo standard 940 070
Components subject to moderate corrosion stress. Externally visible parts with primarily decorative surface requirements which are in direct contact with a normal industrial environment or media such as coolants or lubricating agents

Clevis foot CRLBN, stainless steel

Material:
High-alloy steel
Free of copper, PTFE and silicone

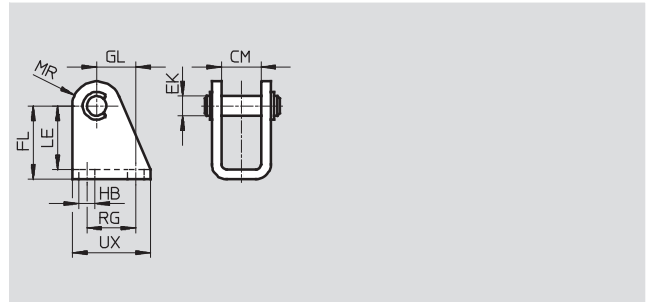

Dimensions and ordering data													
For \varnothing	CM	EK	FL	GL	HB	LE	MR	RG	UX	CRC ¹⁾	Weight	Part No.	Type
[mm]		\varnothing									[g]		
25	16.1	8	30 +0.4/-0.2	16	6.6	26	10	20	32	4	62	161 863	CRLBN-20/25

1) Corrosion resistance class 4 to Festo standard 940 070
Components requiring higher corrosion resistance. Parts used with aggressive media, e.g. food or chemical industry. These applications should be supported with special tests with the media if required

High-force cylinders ADNH, standard port pattern

Accessories

Swivel flange SNCB/SNCB-...-R3

Material:
 SNCB: Die-cast aluminium
 SNCB-...-R3: Die-cast aluminium with protective coating, high corrosion protection
 Free of copper, PTFE and silicone

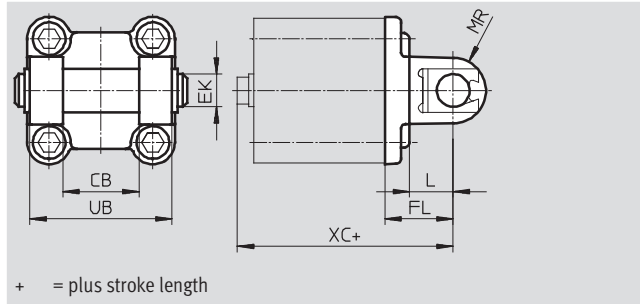

Dimensions and ordering data							
For Ø	CB	EK	FL	L	MR	UB	XC
[mm]	H14	∅ e8	±0.2			h14	
40	28	12	25	16	12	52	76
63	40	16	32	21	16	70	89
100	60	20	41	27	20	110	117

For Ø [mm]	Basic version				R3 – High corrosion protection			
	CRC ¹⁾	Weight [g]	Part No.	Type	CRC ¹⁾	Weight [g]	Part No.	Type
40	2	150	174 391	SNCB-40	3	150	176 945	SNCB-40-R3
63	2	365	174 393	SNCB-63	3	365	176 947	SNCB-63-R3
100	2	925	174 395	SNCB-100	3	925	176 949	SNCB-100-R3

1) Corrosion resistance class 2 to Festo standard 940 070
 Components subject to moderate corrosion stress. Externally visible parts with primarily decorative surface requirements which are in direct contact with a normal industrial environment or media such as coolants or lubricating agents.
 Corrosion resistance class 3 to Festo standard 940 070
 Components requiring higher corrosion resistance. External visible parts in direct contact with industrial atmospheres or media such as solvents and cleaning agents, with a predominantly functional requirement for the surface

High-force cylinders ADNH, standard port pattern

Accessories

Trunnion flange ZNCF/CRZNG

Material:

ZNCF: Special steel casting

CRZNG: Electrolytically polished special steel casting

Free of copper, PTFE and silicone

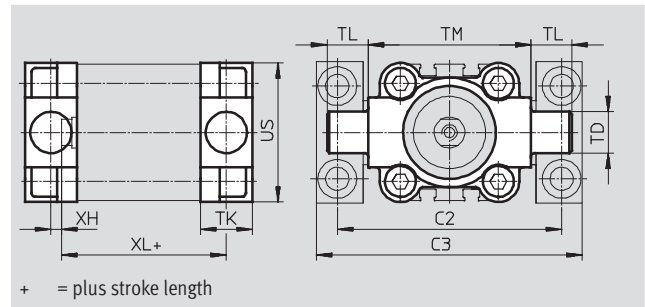

Dimensions and ordering data									
For \varnothing	C2	C3	TD	TK	TL	TM	US	XH	XL
[mm]			\varnothing e9						
40	87	105	16	20	16	63	54	4	55
63	116	136	20	24	20	90	75	4	61
100	164	189	25	38	25	132	110	10	86

For \varnothing	Basic version				R3 – High corrosion protection			
	CRC ¹⁾	Weight [g]	Part No.	Type	CRC ¹⁾	Weight [g]	Part No.	Type
[mm]								
40	2	285	174 412	ZNCF-40	4	285	161 853	CRZNG-40
63	2	687	174 414	ZNCF-63	4	687	161 855	CRZNG-63
100	2	2,254	174 416	ZNCF-100	4	2,254	161 857	CRZNG-100

- 1) Corrosion resistance class 2 to Festo standard 940 070
 Components subject to moderate corrosion stress. Externally visible parts with primarily decorative surface requirements which are in direct contact with a normal industrial environment or media such as coolants or lubricating agents.
 Corrosion resistance class 4 to Festo standard 940 070
 Components requiring higher corrosion resistance. Parts used with aggressive media, e.g. food or chemical industry. These applications should be supported with special tests with the media if required

Trunnion support LNZG

Material:

Trunnion support: Anodised aluminium

Plain bearing: Plastic

Free of copper, PTFE and silicone

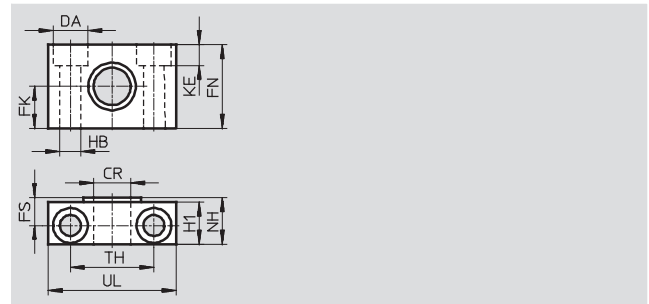
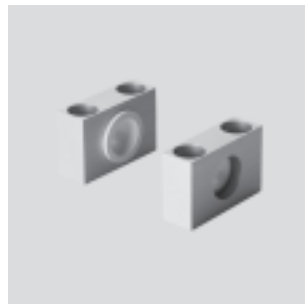





Dimensions and ordering data															
For \varnothing	CR	DA	FK	FN	FS	H1	HB	KE	NH	TH	UL	CRC ¹⁾	Weight	Part No.	Type
[mm]	\varnothing D11	\varnothing H13	\varnothing ± 0.1				\varnothing H13			± 0.2			[g]		
40	16	15	18	36	12	18	9	9	21	36	55	2	400	32 960	LNZG-40/50
63	20	18	20	40	13	20	11	11	23	42	65	2	480	32 961	LNZG-63/80
100	25	20	25	50	16	24.5	14	13	28.5	50	75	2	960	32 962	LNZG-100/125



- 1) Corrosion resistance class 2 to Festo standard 940 070
 Components subject to moderate corrosion stress. Externally visible parts with primarily decorative surface requirements which are in direct contact with a normal industrial environment or media such as coolants or lubricating agents

High-force cylinders ADNH, standard port pattern

Accessories

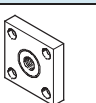
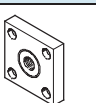
FESTO

Ordering data – Piston rod attachments				Technical data → Internet: piston rod attachment			
Designation	For Ø	Part No.	Type	Designation	For Ø	Part No.	Type
Rod eye SGS				Rod clevis SGA for rod eye SGS			
	25	9 255	SGS-M8		25	–	
	40	9 262	SGS-M12x1,25		40	10 767	SGA-M12x1,25
	63	9 263	SGS-M16x1,5		63	10 768	SGA-M16x1,5
	100	9 264	SGS-M20x1,5		100	10 769	SGA-M20x1,5
Rod clevis SG				Self-aligning rod coupler FK			
	25	3 111	SG-M8		25	2 062	FK-M8
	40	6 145	SG-M12x1,25		40	6 141	FK-M12x1,25
	63	6 146	SG-M16x1,5		63	6 142	FK-M16x1,5 ¹⁾
	100	6 147	SG-M20x1,5		100	6 143	FK-M20x1,5 ¹⁾
Coupling piece KSG				 <p>Note</p> <p>¹⁾ If these piston-rod attachments are used, the maximum force of 10,000 N must not be exceeded.</p>			
	25	–					
	40	32 964	KSG-M12x1,25				
	63	32 965	KSG-M16x1,5				
	100	32 966	KSG-M20x1,5				

Ordering data – Corrosion and acid resistant piston rod attachments				Technical data → Internet: piston rod attachment			
Designation	For Ø	Part No.	Type	Designation	For Ø	Part No.	Type
Rod eye CRSGS				Rod clevis CRSG			
	25	195 581	CRSGS-M8		25	13 568	CRSG-M8
	40	195 583	CRSGS-M12x1,25		40	13 570	CRSG-M12x1,25
	63	195 584	CRSGS-M16x1,5		63	13 571	CRSG-M16x1,5
	100	195 585	CRSGS-M20x1,5		100	13 572	CRSG-M20x1,5

 Note

Piston rod attachments for cylinders with special thread (variant K5)

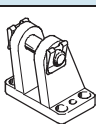
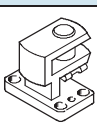

→ www.festo.com

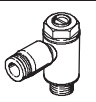

Ordering data – Mounting attachments				Technical data → Internet: mounting attachment			
Designation	For Ø	Part No.	Type	Designation	For Ø	Part No.	Type
Clevis foot LBG for rod eye SGS				Right-angle clevis foot LQG for rod eye SGS			
	25	–			25	–	
	40	31 762	LBG-40		40	31 769	LQG-40
	63	31 764	LBG-63		63	31 771	LQG-63
	100	31 766	LBG-100		100	31 773	LQG-100

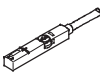

Ordering data – One-way flow control valves				Technical data → Internet: grla			
Designation	Connection		Material	Part No.	Type		
	For Ø	For tubing O.D.					
For exhaust air							
	25, 40		3	Metal design	193 137	GRLA-M5-QS-3-D	
			4		193 138	GRLA-M5-QS-4-D	
	63, 100		4		193 143	GRLA-1/8-QS-4-D	
			6		193 144	GRLA-1/8-QS-6-D	
			8		193 145	GRLA-1/8-QS-8-D	

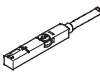
High-force cylinders ADNH, standard port pattern

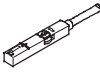
Accessories

Ordering data – Proximity sensors for T-slot, magneto-resistive					Technical data → Internet: smt	
	Type of mounting	Switch output	Electrical connection	Cable length [m]	Part No.	Type
N/O contact						
	Insertable in the slot from above, flush with cylinder profile	PNP	Cable, 3-wire	2.5	543 867	SMT-8M-PS-24V-K-2,5-OE
			Plug M8x1, 3-pin	0.3	543 866	SMT-8M-PS-24V-K-0,3-M8D
			Plug M12x1, 3-pin	0.3	543 869	SMT-8M-PS-24V-K-0,3-M12
		NPN	Cable, 3-wire	2.5	543 870	SMT-8M-NS-24V-K-2,5-OE
Plug M8x1, 3-pin	0.3		543 871	SMT-8M-NS-24V-K-0,3-M8D		
	Insertable in the slot lengthwise, flush with the cylinder profile	PNP	Cable, 3-wire	2.5	175 436	SMT-8-PS-K-LED-24-B
			Plug M8x1, 3-pin	0.3	175 484	SMT-8-PS-S-LED-24-B
N/C contact						
	Insertable in the slot from above, flush with cylinder profile	PNP	Cable, 3-wire	7.5	543 873	SMT-8M-PO-24V-K7,5-OE

Ordering data – Proximity sensors for T-slot, magnetic reed					Technical data → Internet: sme		
	Type of mounting	Switch output	Electrical connection	Cable length [m]	Part No.	Type	
N/O contact							
	Insertable in the slot from above, flush with cylinder profile	Contacting	Cable, 3-wire	2.5	543 862	SME-8M-DS-24V-K-2,5-OE	
				5.0	543 863	SME-8M-DS-24V-K-5,0-OE	
			Plug M8x1, 3-pin	Cable, 3-wire	2.5	543 872	SME-8M-ZS-24V-K-2,5-OE
				0.3	543 861	SME-8M-DS-24V-K-0,3-M8D	
	Insertable in the slot lengthwise, flush with the cylinder profile	Contacting	Cable, 3-wire	2.5	150 855	SME-8-K-LED-24	
			Plug M8x1, 3-pin	0.3	150 857	SME-8-S-LED-24	
N/C contact							
	Insertable in the slot lengthwise, flush with the cylinder profile	Contacting	Cable, 3-wire	7.5	160 251	SME-8-0-K-LED-24	

Ordering data – Connecting cables				Technical data → Internet: nebu	
	Electrical connection, left	Electrical connection, right	Cable length [m]	Part No.	Type
	Straight socket, M8x1, 3-pin	Cable, open end, 3-wire	2.5	541 333	NEBU-M8G3-K-2.5-LE3
			5	541 334	NEBU-M8G3-K-5-LE3
	Straight socket, M12x1, 5-pin	Cable, open end, 3-wire	2.5	541 363	NEBU-M12G5-K-2.5-LE3
			5	541 364	NEBU-M12G5-K-5-LE3
	Angled socket, M8x1, 3-pin	Cable, open end, 3-wire	2.5	541 338	NEBU-M8W3-K-2.5-LE3
			5	541 341	NEBU-M8W3-K-5-LE3
	Angled socket, M12x1, 5-pin	Cable, open end, 3-wire	2.5	541 367	NEBU-M12W5-K-2.5-LE3
			5	541 370	NEBU-M12W5-K-5-LE3

High-force cylinders ADNH, standard port pattern

Accessories

Ordering data – Rectangular proximity sensors, pneumatic		Technical data → Internet: smpo	
Pneumatic connection	Part No.	Type	
3/2-way valve, normally closed			
	Female thread M5	178 563	SMPO-8E

Ordering data – Mounting kit for proximity sensors SMPO-8E		Technical data → Internet: smb	
Assembly	Part No.	Type	
	Clamped in T-slot	178 230	SMB-8E

Ordering data – Slot cover for T-slot			
Assembly	Length	Part No.	Type
	Insertable from above	2x 0.5 m	151 680 ABP-5-S