

Clamping-unit cylinders, standard port pattern



Clamping-unit cylinders, standard port pattern

Key features

FESTO

At a glance

Clamping units are generally used for the friction locking of longitudinally variable rods at any position. The attachment of a clamping unit to a pneumatic cylinder allows the piston rod to be clamped. This clamping unit is designed to lock the piston rod securely so that the application of

external force on the piston rod does not produce any relative motion. The locking of the piston rod can take place at any position in the stroke, in the end positions as well as the intermediate positions.

- Clamping force is released when compressed air is fed to the clamping unit
- Static holding force of up to 8,000 N
- The cylinders comply with ISO 15552, (DIN ISO 6431), except where length is concerned.

Selection aid

Clamping-unit cylinder DNCKE

6



- **For use as holding device (static application):**
 - Holding and clamping in the event of a power failure
 - Protection against pressure failure and pressure drop
 - Securing of the piston rod during intermediate stops for process operations
- Wide selection of mounting options

Clamping-unit cylinder DNCKE-S, for safety-related applications

9



- **For use as holding device (static application):**
 - Holding and clamping in the event of a power failure
 - Protection against pressure failure and pressure drop
 - Securing of the piston rod during intermediate stops for process operations
- **For use as a braking device (dynamic application):**
 - Braking or stopping of movements
 - Suspension of movement upon entering a danger area
- Holding force of the clamping unit is greater than the max. permissible feed force of the cylinder
- Suitable for use in safety-related parts of control systems belonging to category 1 to EN ISO 13849-1 (reliable component). For use in higher categories, additional control measures are required.
- Certified for use in safety-relevant control systems by the BG-Institute for Occupational Safety and Health (Berufsgenossenschaftlichen Institut für Arbeitsschutz – BIA) in Germany
- When used as a braking device, the overtravel must be checked regularly
- CE marking as per EC machinery directive
- Products intended for use in safety-related applications must be selected, sized and arranged in accordance with the risk assessment (EN ISO 14121-1) as well as any other valid standards and regulations

Clamping-unit cylinders, standard port pattern

Type codes

		DNCKE	-	63	-	100	-	PPV	-	A	-	S
Type												
Double-acting												
DNCKE	Clamping-unit cylinder											
Piston Ø [mm]												
Stroke [mm]												
Cushioning												
PPV	Adjustable at both ends											
Position sensing												
A	For proximity sensing											
Certification												
S	Safety component to Machinery Directive 2006/42/EC. Approved for use in safety-related parts of control systems. Certified by the Institute for Occupational Safety and Health (Berufsgenossenschaftlichen Institut für Arbeitsschutz - BIA) in Germany.											

Clamping-unit cylinders, standard port pattern

Peripherals overview

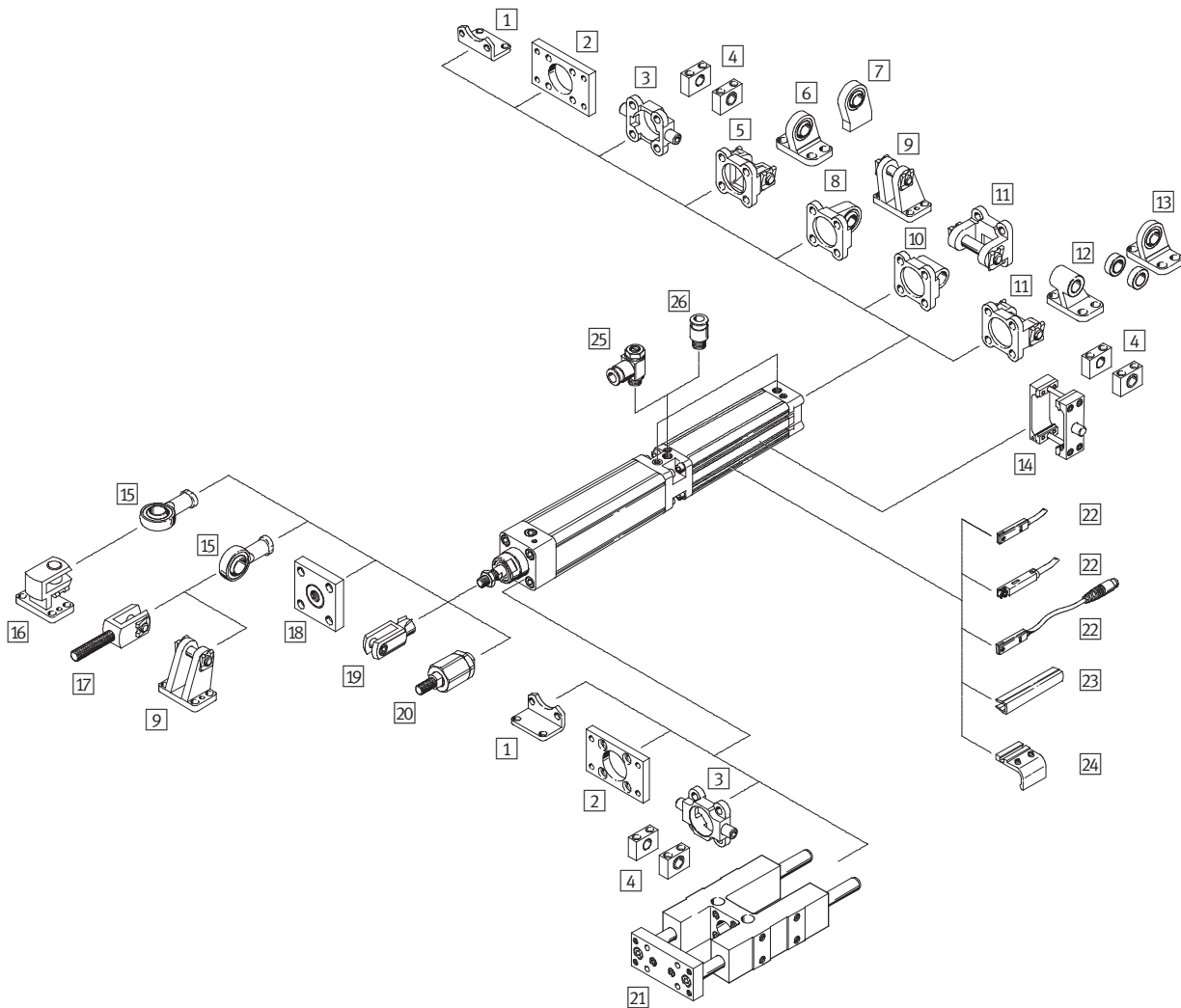

Clamping-unit cylinders, standard port pattern

Peripherals overview

FESTO



Mounting attachments and accessories				
	Brief description	DNCKE	DNCKE-S	→ Page/Internet
1	Foot mounting HNC	■	■	13
2	Flange mounting FNC	■	■	13
3	Trunnion flange ZNCF	■	–	14
4	Trunnion support LNZG	■	–	15
5	Swivel flange SNC	■	–	15
6	Clevis foot LSNG	■	–	17
7	Clevis foot LSNSG	■	–	17
8	Swivel flange SNCS	■	–	16
9	Clevis foot LBG	■	–	17
10	Swivel flange SNCL	■	–	17
11	Swivel flange SNCB	■	–	16
12	Clevis foot LNG	■	–	17
13	Clevis foot LSN	■	–	17
14	Trunnion mounting kit ZNCM	■	–	14
15	Rod eye SGS	■	–	18
16	Right-angle clevis foot LQG	■	–	17
17	Rod clevis SGA	■	–	18
18	Coupling piece KSG	■	–	18
19	Rod clevis SG	■	–	18
20	Self-aligning rod coupler FK	■	■	18
21	Guide unit FENG	■	■	18
22	Proximity sensor SME/SMT	■	■	19
23	Slot cover ABP-5-S	■	■	20
24	Sensor mounting kit SMB-8-FENG	■	■	19
25	One-way flow control valve GRLA	■	■	20
26	Push-in fitting QS	■	■	quick star

Clamping unit cylinders DNCKE, standard port pattern

Technical data

Function



-  - Diameter
40, 63, 100 mm
-  - Stroke length
10 ... 2,000 mm

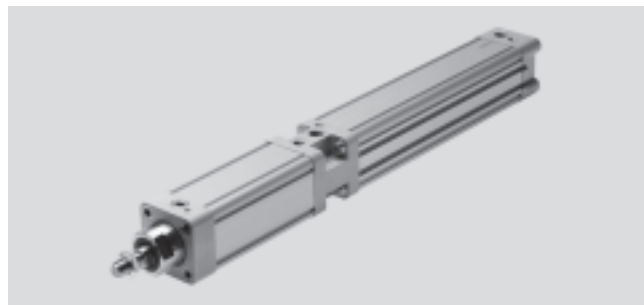

- - Note

Additional measures are required for use in safety-related control systems; in Europe, for example, the standards listed under the EC Machinery Directive must be observed. Without additional measures in accordance with statutory minimum requirements, the product is not suitable for use in safety-related sections of control systems.

General technical data				
Piston Ø		40	63	100
Pneumatic connection	Cylinder	G1/4	G3/8	G1/2
	Clamping unit	G1/8	G1/4	G3/8
Piston rod thread		M12x1.25	M16x1.5	M20x1.5
Design	Piston			
	Piston rod			
	Cylinder barrel			
Cushioning		Adjustable at both ends		
Cushioning length	[mm]	20	22	32
Position sensing		For proximity sensing		
Type of mounting	Via female thread			
	With accessories			
Clamping type with effective direction	At both ends			
	Clamping via spring force, air to release			
Assembly position		Any		

-  - Note: This product conforms to ISO 1179-1 and to ISO 228-1

Operating and environmental conditions				
Piston Ø		40	63	100
Operating medium		Filtered compressed air, lubricated or unlubricated		
Operating pressure	[bar]	0.6 ... 10		
Min. release pressure	[bar]	3.8		
Ambient temperature ¹⁾	[°C]	-20 ... +80		

1) Note operating range of proximity sensors

Weights [g]				
Piston Ø		40	63	100
Basic weight with 0 mm stroke		2,340	5,485	18,160
Additional weight per 10 mm stroke		45	73	110
Moving load with 0 mm stroke		500	935	2,150
Additional load per 10 mm stroke		16	25	40

Clamping unit cylinders DNCKE, standard port pattern

Technical data

Forces [N]			
Piston Ø	40	63	100
Theoretical force at 6 bar, advancing	754	1,870	4,712
Theoretical force at 6 bar, retracting	633	1,682	4,418
Static holding force	1,300	3,200	8,000

 Note

The specified holding force refers to a static load. If this value is exceeded, slippage may occur. Dynamic forces occurring during operation must not exceed the static holding force if slippage is to be avoided. The clamping unit is backlash-free in the clamped condition if varying loads are applied to the piston rod.

Activation:
The clamping unit may only be released when equilibrium of forces is present on the piston rod. Otherwise there is a risk of accidents due to the sudden movement of the piston rod. Blocking off the air supply at both ends (e.g. with a 5/3-way valve) does not provide any safety.

Impact energy [J]			
Piston Ø	40	63	100
Max. impact energy at end positions	0.7	1.3	3

Permissible impact velocity:
$$v_{perm.} = \sqrt{\frac{2 \times E_{perm.}}{m_{dead} + m_{load}}}$$

Maximum permissible load:
$$m_{load} = \frac{2 \times E_{perm.}}{v^2} - m_{dead}$$

$v_{perm.}$ Permissible impact velocity
 $E_{perm.}$ Max. impact energy
 m_{dead} Moving load (drive)
 m_{load} Moving work load

 Note

These specifications represent the maximum values which can be reached. Note the maximum permitted impact energy.

Materials

Sectional view

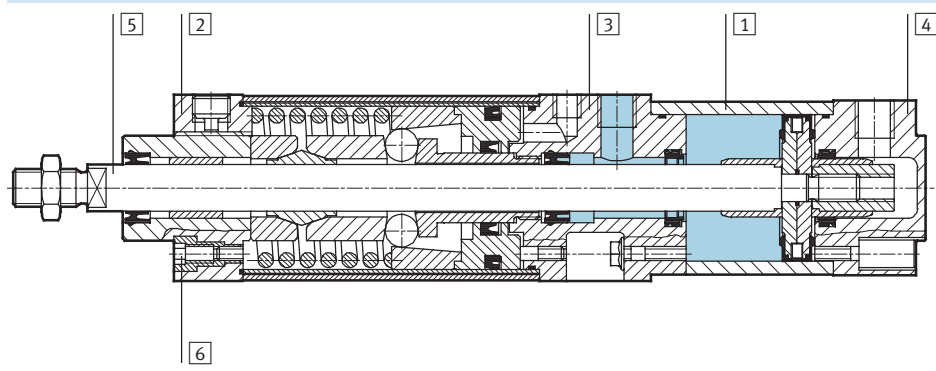

Cylinder		
1	Housing	Wrought aluminium alloy
2	Bearing cap	Wrought aluminium alloy
3	Connector cap	Wrought aluminium alloy
4	End cap	Die-cast aluminium
5	Piston rod	Tempered steel
6	Flange screws	Tempered steel
-	Seals	Polyurethane, nitrile rubber

Clamping unit cylinders DNCKE, standard port pattern

Technical data

FESTO

Dimensions

Download CAD data → www.festo.com

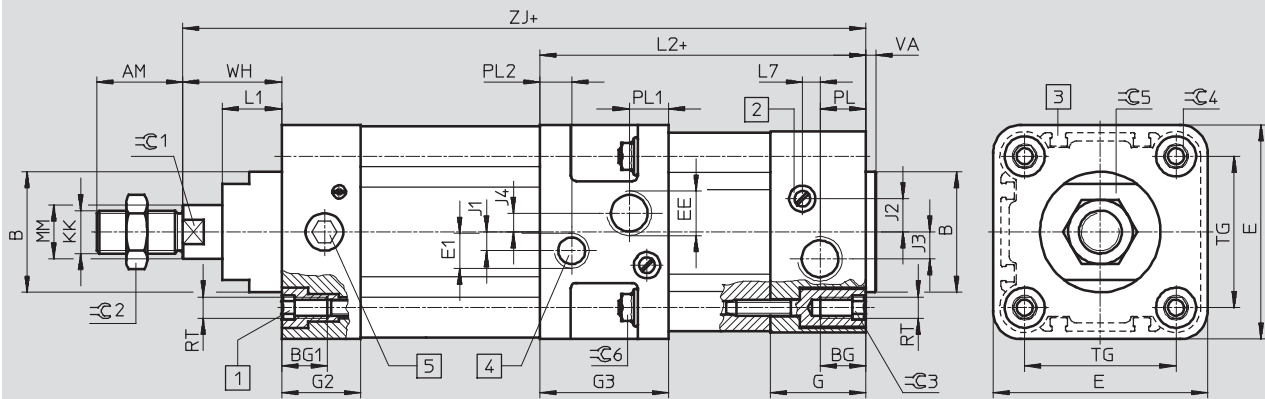

- 1 Socket head screw with female thread for mounting components
 - 2 Regulating screw for adjustable end-position cushioning
 - 3 Sensor slot for proximity sensor
 - 4 Connection to release clamping function
 - 5 Locking screw
- + = plus stroke length

∅ [mm]	AM	B ∅ d11	BG	BG1	E	EE	E1	G	G2	G3	J1
40	24	35	16	15	54	G ¹ / ₄	G ¹ / ₈	28.8	22	49.6	2
63	32	45	17	17	80	G ³ / ₈	G ¹ / ₄	34.3	29.5	47.9	7
100	42	55	17	17	126	G ¹ / ₂	G ³ / ₈	38	32.5	46.7	15

∅ [mm]	J2	J3	J4	KK	L1	L2	L7	MM ∅	PL	PL1	PL2
40	8	6	0	M12x1.25	17.9	114.5	3.6	16	14	21.3	9
63	12.4	10	7	M16x1.5	22.1	121.5	6.6	20	17	14.6	11.8
100	12	10	10	M20x1.5	29.2	131.5	8	25	18.8	16.4	14.4

∅ [mm]	RT	TG	VA	WH	ZJ	CC1	CC2	CC3	CC4	CC5	CC6
40	M6	38	4	30	277	13	19	6	6	30	8
63	M8	56.5	4	37	315	17	24	8	8	36	10
100	M10	89	4	51	408	22	30	6	10	41	13

Note: This product conforms to ISO 1179-1 and to ISO 228-1

Ordering data		Part No.	Type
Piston ∅ [mm]	Stroke [mm]		
40	10 ... 2,000	526 482	DNCKE-40-...-PPV-A
63	10 ... 2,000	526 483	DNCKE-63-...-PPV-A
100	10 ... 2,000	526 484	DNCKE-100-...-PPV-A

Clamping unit cylinders DNCKE-S, standard port pattern

FESTO

Technical data

Function



- \varnothing - Diameter
40, 63, 100 mm
- | - Stroke length
10 ... 2,000 mm



General technical data				
Piston \varnothing		40	63	100
Pneumatic connection	Cylinder	G1/4	G3/8	G1/2
	Clamping unit	G1/8	G1/4	G3/8
Piston rod thread		M12x1.25	M16x1.5	M20x1.5
Design	Piston			
	Piston rod			
	Cylinder barrel			
Cushioning		Adjustable at both ends		
Cushioning length	[mm]	20	22	32
Position sensing		For proximity sensing		
Type of mounting		Via female thread		
		With accessories		
Clamping type with effective direction		At both ends		
		Clamping via spring force, air to release		
Assembly position		Any		
Function		Single-channel to EN ISO 13849-1, category 1		
Certification		BIA (Berufsgenossenschaftliches Institut für Arbeitsschutz – BG-Institute for Occupational Safety and Health)		
CE marking (see declaration of conformity)		To Machinery Directive (2006/42/EC) 98/37/EC		

- | - Note: This product conforms to ISO 1179-1 and to ISO 228-1

Operating and environmental conditions				
Piston \varnothing		40	63	100
Operating medium		Filtered compressed air, lubricated or unlubricated		
Operating pressure	[bar]	0.6 ... 8		
Min. release pressure	[bar]	3.8		
Max. permissible test pressure	[bar]	10		
Ambient temperature ¹⁾	[°C]	-10 ... +60		

1) Note operating range of proximity sensors

Weights [g]				
Piston \varnothing		40	63	100
Basic weight with 0 mm stroke		2,340	5,485	18,160
Additional weight per 10 mm stroke		45	73	110
Moving load with 0 mm stroke		500	935	2,150
Additional load per 10 mm stroke		16	25	40

Clamping unit cylinders DNCKE-S, standard port pattern

Technical data

Forces [N]			
Piston \varnothing	40	63	100
Theoretical force at 6 bar, advancing	754	1,870	4,712
Theoretical force at 6 bar, retracting	633	1,682	4,418
Static holding force	1,300	3,200	8,000

Note

The specified holding force refers to a static load. If this value is exceeded, slippage may occur. Dynamic forces occurring during operation must not exceed the static holding force if slippage is to be avoided. The clamping unit is backlash-free in the clamped condition if varying loads are applied to the piston rod.

Activation:
The clamping unit may only be released when equilibrium of forces is present on the piston rod. Otherwise there is a risk of accidents due to the sudden movement of the piston rod. Blocking off the air supply at both ends (e.g. with a 5/3-way valve) does not provide any safety.

Theoretical overtravel s as a function of the piston speed v in a vertical assembly position

The overtravel is the distance that the piston rod covers between exhausting of the clamping unit and coming to a standstill. It must be determined by the customer when setting up the machine and be compared with the calculated overtravel → DIN EN 999/EN ISO 13849-2. The clamping unit DNCKE-S can be used in safety-related parts of control systems belonging to category 1 (reliable component) as defined by EN ISO 13849-1. For use in higher categories than category 1 to EN ISO 13849-1, the overtravel must be achieved even in the event of faults.

It is dependent on the environmental conditions and stress, e.g.:

- Operating pressure
- Nominal size of switching valve
- Line length
- Diameter of connecting cable to clamping unit
- Load and speed

The overtravel can be reduced by attaching a quick exhaust valve to the supply port of the clamping unit.

$\varnothing 40$ $\varnothing 63$

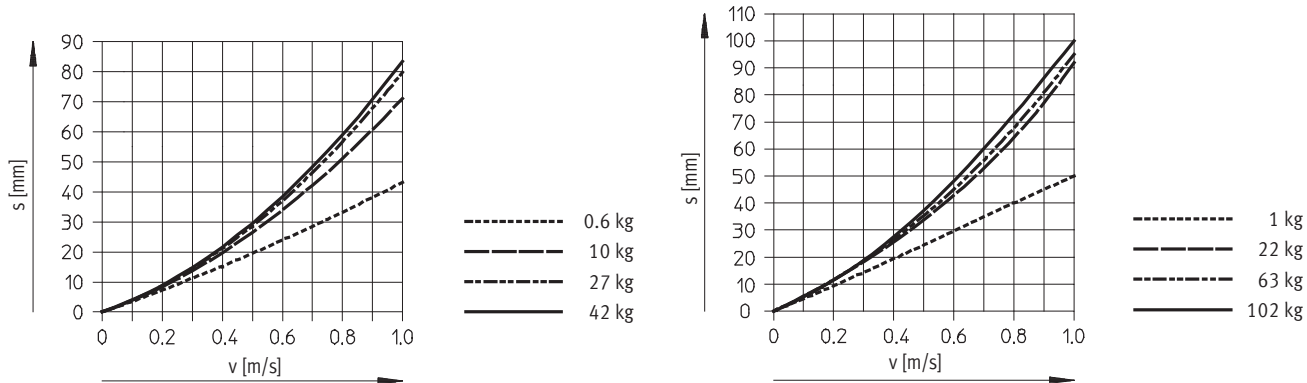

$\varnothing 100$

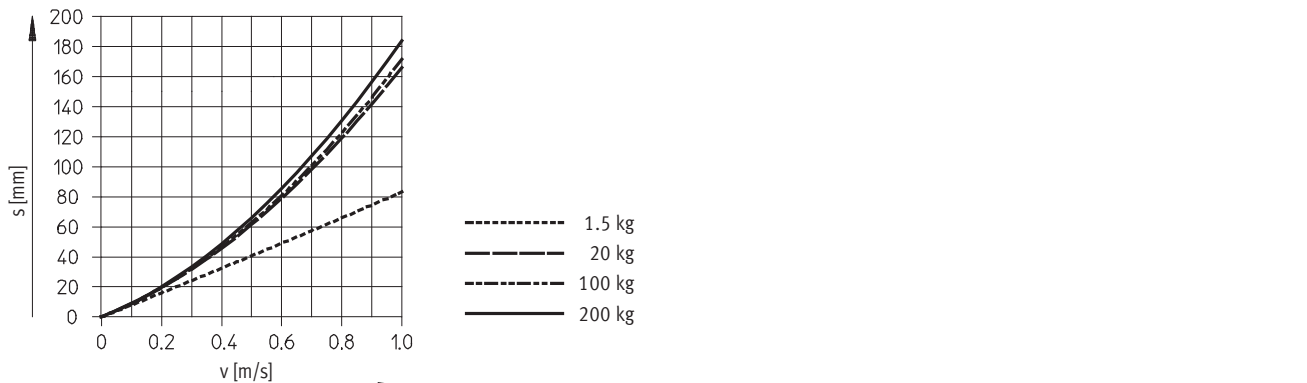

Clamping unit cylinders DNCKE-S, standard port pattern

Technical data

Impact energy [J]			
Piston Ø	40	63	100
Max. impact energy at end positions	0.7	1.3	3

Permissible impact velocity:

$$v_{perm.} = \sqrt{\frac{2 \times E_{perm.}}{m_{dead} + m_{load}}}$$

$v_{perm.}$ Permissible impact velocity
 $E_{perm.}$ Max. impact energy
 m_{dead} Moving load (drive)
 m_{load} Moving work load

Maximum permissible load:

$$m_{load} = \frac{2 \times E_{perm.}}{v^2} - m_{dead}$$

 - Note
 These specifications represent the maximum values which can be reached. Note the maximum permitted impact energy.

Materials

Sectional view

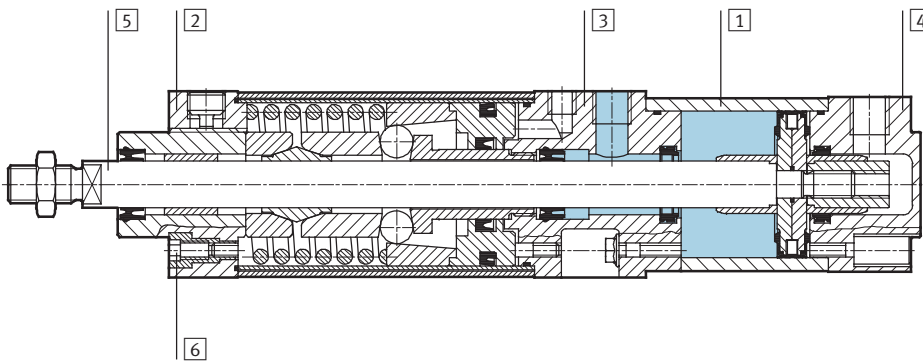

Cylinder		
1	Body	Wrought aluminium alloy
2	Bearing cap	Wrought aluminium alloy
3	Connector cap	Wrought aluminium alloy
4	End cap	Die-cast aluminium
5	Piston rod	Tempered steel
6	Flange screws	Tempered steel
-	Seals	Polyurethane, nitrile rubber

Recommendation for mounting

As holding device, horizontal installation

With foot mounting HNC

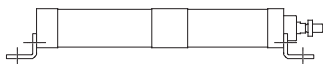

As braking device, vertical installation

With flange mounting FNC (note braking direction)

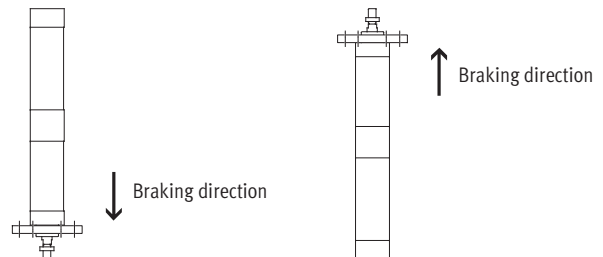

Clamping unit cylinders DNCKE-S, standard port pattern

Technical data

FESTO

Dimensions

Download CAD data → www.festo.com

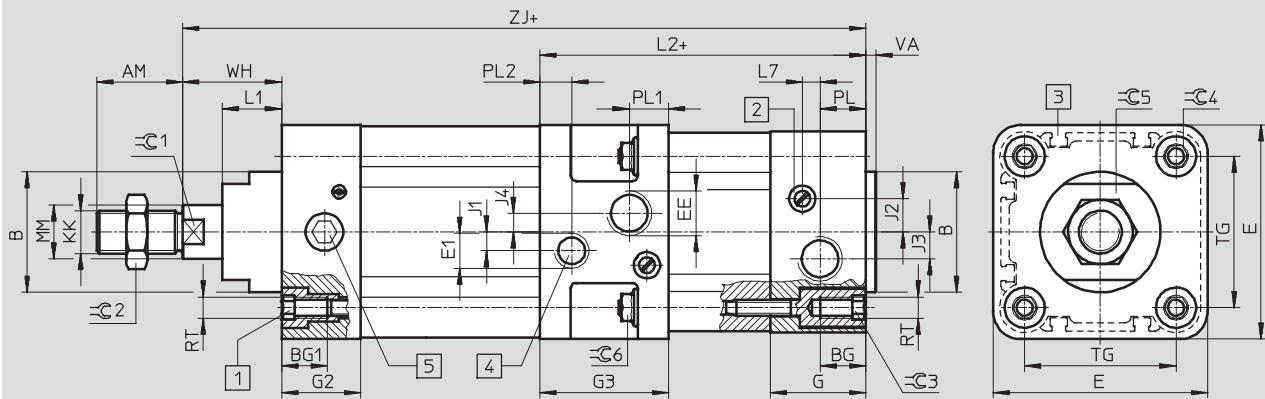

- 1 Socket head screw with female thread for mounting components
 - 2 Regulating screw for adjustable end-position cushioning
 - 3 Sensor slot for proximity sensor
 - 4 Connection to release clamping function
 - 5 Locking screw
- + = plus stroke length

∅ [mm]	AM	B ∅ d11	BG	BG1	E	EE	E1	G	G2	G3	J1
40	24	35	16	15	54	G ¹ / ₄	G ¹ / ₈	28.8	22	49.6	2
63	32	45	17	17	80	G ³ / ₈	G ¹ / ₄	34.3	29.5	47.9	7
100	42	55	17	17	126	G ¹ / ₂	G ³ / ₈	38	32.5	46.7	15

∅ [mm]	J2	J3	J4	KK	L1	L2	L7	MM ∅	PL	PL1	PL2
40	8	6	0	M12x1.25	17.9	114.5	3.6	16	14	21.3	9
63	12.4	10	7	M16x1.5	22.1	121.5	6.6	20	17	14.6	11.8
100	12	10	10	M20x1.5	29.2	131.5	8	25	18.8	16.4	14.4

∅ [mm]	RT	TG	VA	WH	ZJ	∅C1	∅C2	∅C3	∅C4	∅C5	∅C6
40	M6	38	4	30	277	13	19	6	6	30	8
63	M8	56.5	4	37	315	17	24	8	8	36	10
100	M10	89	4	51	408	22	30	6	10	41	13

Note: This product conforms to ISO 1179-1 and to ISO 228-1

Ordering data

Piston ∅ [mm]	Stroke [mm]	Part No.	Type
40	10 ... 2,000	538 239	DNCKE-40-...-PPV-A-S
63	10 ... 2,000	538 240	DNCKE-63-...-PPV-A-S
100	10 ... 2,000	538 241	DNCKE-100-...-PPV-A-S

Clamping-unit cylinders, standard port pattern

Accessories



Foot mounting HNC

Material:
Galvanised steel
Free of copper, PTFE and silicone

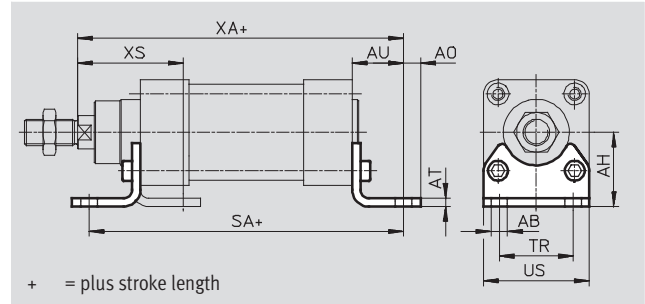

Dimensions and ordering data														
For \varnothing	AB \varnothing	AH	AO	AT	AU	SA	TR	US	XA	XS	CRC ¹⁾	Weight	Part No.	Type
[mm]												[g]		
40	10	36	9	4	28	303	36	54	305	53	2	193	174 370	HNC-40
63	10	50	12.5	5	32	342	50	75	347	63	2	436	174 372	HNC-63
100	14.5	71	17.5	6	41	439	75	110	449	86	2	1,009	174 374	HNC-100

1) Corrosion resistance class 2 according to Festo standard 940 070
Components requiring moderate corrosion resistance. Externally visible parts with primarily decorative surface requirements which are in direct contact with a normal industrial environment or media such as coolants or lubricating agents.

Flange mounting FNC

Material:
Galvanised steel
Free of copper, PTFE and silicone

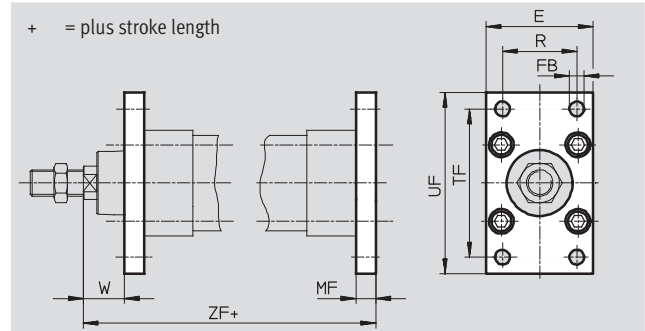

Dimensions and ordering data													
For \varnothing	E	FB \varnothing	MF	R	TF	UF	W	ZF	CRC ¹⁾	Weight	Part No.	Type	
[mm]		H13								[g]			
40	54	9	10	36	72	90	20	287	2	280	174 377	FNC-40	
63	75	9	12	50	100	120	25	327	2	690	174 379	FNC-63	
100	110	14	16	75	150	175	35	424	2	2,400	174 381	FNC-100	

1) Corrosion resistance class 2 according to Festo standard 940 070
Components requiring moderate corrosion resistance. Externally visible parts with primarily decorative surface requirements which are in direct contact with a normal industrial environment or media such as coolants or lubricating agents.

Clamping-unit cylinders, standard port pattern

Accessories



Trunnion flange ZNCF

Material:
Special steel casting
Free of copper, PTFE and silicone

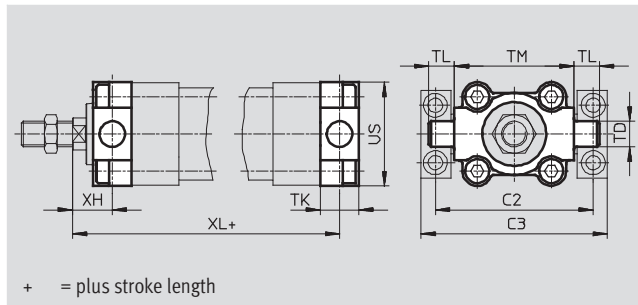

+ = plus stroke length

Dimensions and ordering data													
For Ø	C2	C3	TD	TK	TL	TM	US	XH	XL	CRC ¹⁾	Weight	Part No.	Type
[mm]			Ø								[g]		
40	87	105	16	20	16	63	54	20	287	2	285	174 412	ZNCF-40
63	116	136	20	24	20	90	75	25	327	2	687	174 414	ZNCF-63
100	164	189	25	38	25	132	110	32	427	2	2,254	174 416	ZNCF-100

1) Corrosion resistance class 2 according to Festo standard 940 070
Components requiring moderate corrosion resistance. Externally visible parts with primarily decorative surface requirements which are in direct contact with a normal industrial environment or media such as coolants or lubricating agents.

Trunnion mounting kit ZNCM

The mounting kit can be attached at any position along the profile barrel of a cylinder.

Material:
Tempered steel

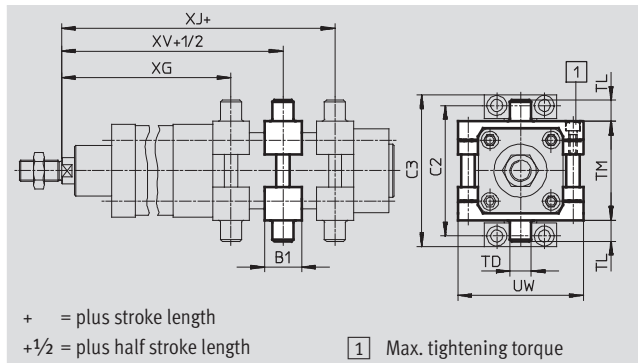

+ = plus stroke length
+1/2 = plus half stroke length

1 Max. tightening torque

Dimensions and ordering data							
For Ø	B1	C2	C3	TD	TL	TM	UW
[mm]				Ø			
40	32	87	105	16	16	63	75
63	41	116	136	20	20	90	105
100	48	164	189	25	25	132	145

For Ø	XG	XJ	XV	Max. tightening torque	CRC ¹⁾	Weight	Part No.	Type
[mm]				[Nm]		[g]		
40	228.1	232.2	230.2	8+1	2	385	163 526	ZNCM-40
63	261.9	260.2	261	18+2	2	890	163 528	ZNCM-63
100	347.2	346	346.6	28+2	2	2,045	163 530	ZNCM-100

1) Corrosion resistance class 2 according to Festo standard 940 070
Components requiring moderate corrosion resistance. Externally visible parts with primarily decorative surface requirements which are in direct contact with a normal industrial environment or media such as coolants or lubricating agents.

Clamping-unit cylinders, standard port pattern

Accessories

Trunnion support LNZG

Material:
 Trunnion support:
 Anodised aluminium
 Plain bearing:
 Plastic

 Free of copper, PTFE and silicone

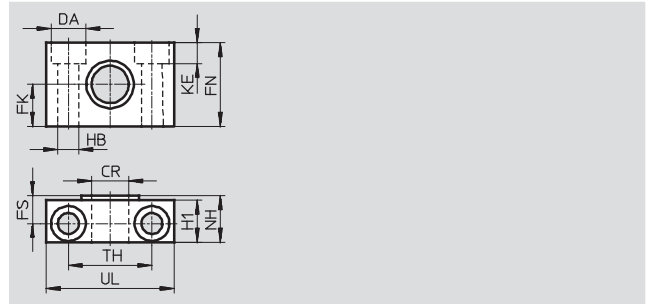

Dimensions and ordering data														Weight	Part No.	Type
For \varnothing	CR	DA	FK	FN	FS	H1	HB	KE	NH	TH	UL	CRC ¹⁾	Weight	Part No.	Type	
[mm]	\varnothing D11	\varnothing H13	\varnothing ± 0.1				\varnothing H13			± 0.2			[g]			
40	16	15	18	36	12	18	9	9	21	36	55	2	400	32 960	LNZG-40/50	
63	20	18	20	40	13	20	11	11	23	42	65	2	480	32 961	LNZG-63/80	
100	25	20	25	50	16	24.5	14	13	28.5	50	75	2	960	32 962	LNZG-100/125	

1) Corrosion resistance class 2 according to Festo standard 940 070
 Components requiring moderate corrosion resistance. Externally visible parts with primarily decorative surface requirements which are in direct contact with a normal industrial environment or media such as coolants or lubricating agents.

Swivel flange SNC

Material:
 Die-cast aluminium

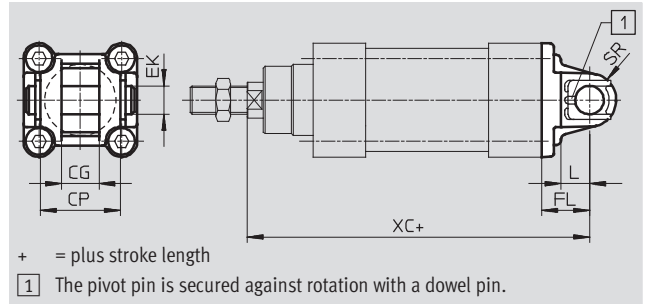

Dimensions and ordering data											Weight	Part No.	Type
For \varnothing	CG	CP	EK	FL	L	SR	XC	CRC ¹⁾	Weight	Part No.	Type		
[mm]	H14	d12	\varnothing	± 0.2					[g]				
40	16	40	12	25	16	12	302	2	120	174 384	SNC-40		
63	21	51	16	32	21	16	347	2	320	174 386	SNC-63		
100	25	75	20	41	27	20	449	2	830	174 388	SNC-100		

1) Corrosion resistance class 2 according to Festo standard 940 070
 Components requiring moderate corrosion resistance. Externally visible parts with primarily decorative surface requirements which are in direct contact with a normal industrial environment or media such as coolants or lubricating agents.

Clamping-unit cylinders, standard port pattern

Accessories

Swivel flange SNCB

Material:
Die-cast aluminium
Free of copper, PTFE and silicone

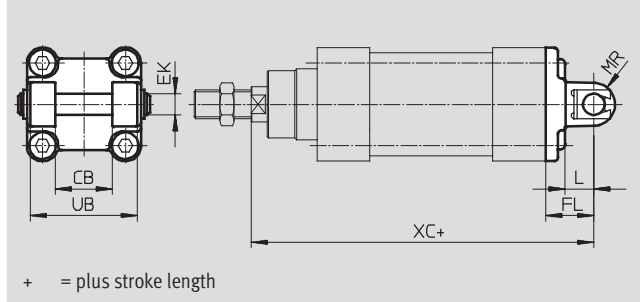

Dimensions and ordering data												
For \varnothing	CB	EK \varnothing	FL	L	ML	MR	UB	XC	CRC ¹⁾	Weight	Part No.	Type
[mm]	H14	e8	± 0.2				h14			[g]		
40	28	12	25	16	63	12	52	302	2	150	174 391	SNCB-40
63	40	16	32	21	83	16	70	347	2	365	174 393	SNCB-63
100	60	20	41	27	127	20	110	449	2	925	174 395	SNCB-100

1) Corrosion resistance class 2 according to Festo standard 940 070
Components requiring moderate corrosion resistance. Externally visible parts with primarily decorative surface requirements which are in direct contact with a normal industrial environment or media such as coolants or lubricating agents.

Swivel flange SNCS

Material:
Die-cast aluminium

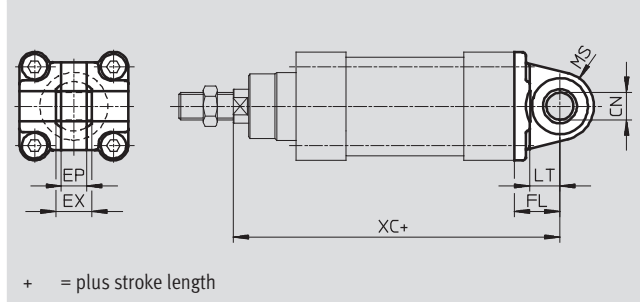
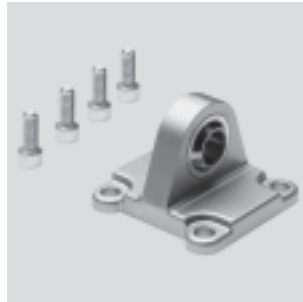

Dimensions and ordering data											
For \varnothing	CN \varnothing	EP	EX	FL	LT	MS	XC	CRC ¹⁾	Weight	Part No.	Type
[mm]	H7	± 0.2		± 0.2					[g]		
40	12	12	16	25	16	17	302	2	125	174 398	SNCS-40
63	16	15	21	32	21	22	347	2	280	174 400	SNCS-63
100	20	18	25	41	27	29	449	2	700	174 402	SNCS-100

1) Corrosion resistance class 2 according to Festo standard 940 070
Components requiring moderate corrosion resistance. Externally visible parts with primarily decorative surface requirements which are in direct contact with a normal industrial environment or media such as coolants or lubricating agents.

Clamping-unit cylinders, standard port pattern

Accessories



Swivel flange SNCL

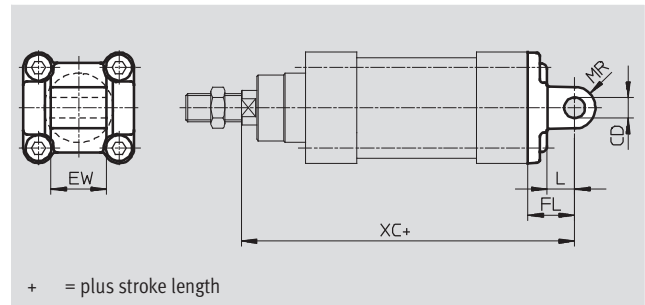
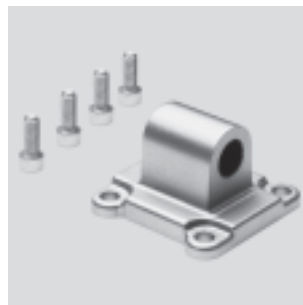

Material:
Die-cast aluminium
Free of copper, PTFE and silicone



+ = plus stroke length

Dimensions and ordering data										
For \varnothing	CD	EW	FL	L	MR	XC	CRC ¹⁾	Weight	Part No.	Type
[mm]	\varnothing H9	-0.2/-0.6	± 0.2					[g]		
40	12	28	25	16	12	302	2	100	174 405	SNCL-40
63	16	40	32	21	16	347	2	250	174 407	SNCL-63
100	20	60	41	27	20	449	2	655	174 409	SNCL-100

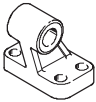
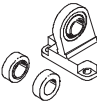
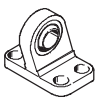

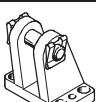
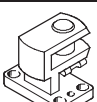

1) Corrosion resistance class 2 according to Festo standard 940 070
Components requiring moderate corrosion resistance. Externally visible parts with primarily decorative surface requirements which are in direct contact with a normal industrial environment or media such as coolants or lubricating agents.

Ordering data – Mounting attachments				Technical data → Internet: mounting attachment			
Designation	For \varnothing	Part No.	Type	Designation	For \varnothing	Part No.	Type
Clevis foot LNG				Clevis foot LSN			
	40	33 891	LNG-40		40	5 562	LSN-40
	63	33 893	LNG-63		63	5 564	LSN-63
	100	33 895	LNG-100		100	5 566	LSN-100
Clevis foot LSNG				Clevis foot LSNSG			
	40	31 741	LSNG-40		40	31 748	LSNSG-40
	63	31 743	LSNG-63		63	31 750	LSNSG-63
	100	31 745	LSNG-100		100	31 752	LSNSG-100
Clevis foot LBG				Clevis foot, right-angled LQG			
	40	31 762	LBG-40		40	31 769	LQG-40
	63	31 764	LBG-63		63	31 771	LQG-63
	100	31 766	LBG-100		100	31 773	LQG-100

Clamping-unit cylinders, standard port pattern

Accessories

FESTO

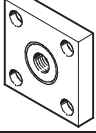
Ordering data – Piston rod attachments				Technical data → Internet: piston rod attachment			
Designation	For Ø	Part No.	Type	Designation	For Ø	Part No.	Type
Rod eye SGS				Rod clevis SGA			
	40	9 262	SGS-M12x1,25		40	10 767	SGA-M12x1,25
	63	9 263	SGS-M16x1,5		63	10 768	SGA-M16x1,5
	100	9 264	SGS-M20x1,5		100	10 769	SGA-M20x1,5
Rod clevis SG				Self-aligning rod coupler FK			
	40	6 145	SG-M12x1,25		40	6 141	FK-M12x1,25
	63	6 146	SG-M16x1,5		63	6 142	FK-M16x1,5
	100	6 147	SG-M20x1,5		100	6 143	FK-M20x1,5
Coupling piece KSG							
	40	32 964	KSG-M12x1,25				
	63	32 965	KSG-M16x1,5				
	100	32 966	KSG-M20x1,5				

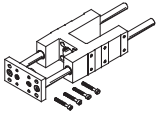

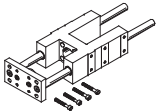
Ordering data – Guide units for fixed strokes (recirculating ball bearing guide only)				Technical data → Internet: feng			
	Stroke [mm]	Part No.	Type	Stroke [mm]	Part No.	Type	
	For Ø 40 mm			For Ø 63 mm			
	10 ... 50	34 499	FENG-40-50-KF	10 ... 50	34 513	FENG-63-50-KF	
	10 ... 100	34 500	FENG-40-100-KF	10 ... 100	34 514	FENG-63-100-KF	
	10 ... 160	34 501	FENG-40-160-KF	10 ... 160	34 515	FENG-63-160-KF	
	10 ... 200	34 502	FENG-40-200-KF	10 ... 200	34 516	FENG-63-200-KF	
	10 ... 250	34 503	FENG-40-250-KF	10 ... 250	34 517	FENG-63-250-KF	
	10 ... 320	34 504	FENG-40-320-KF	10 ... 320	34 518	FENG-63-320-KF	
	10 ... 400	150 291	FENG-40-400-KF	10 ... 400	34 519	FENG-63-400-KF	
	10 ... 500	34 505	FENG-40-500-KF	10 ... 500	34 520	FENG-63-500-KF	
	For Ø 100 mm						
	10 ... 50	34 529	FENG-100-50-KF				
	10 ... 100	34 530	FENG-100-100-KF				
	10 ... 160	34 531	FENG-100-160-KF				
	10 ... 200	34 532	FENG-100-200-KF				
	10 ... 250	34 533	FENG-100-250-KF				
	10 ... 320	34 534	FENG-100-320-KF				
	10 ... 400	34 535	FENG-100-400-KF				
	10 ... 500	34 536	FENG-100-500-KF				

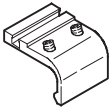

Ordering data – Guide units for variable strokes				Technical data → Internet: feng			
	For Ø [mm]	Stroke [mm]	with recirculating ball bearing guide Part No. Type	with plain bearing guide Part No. Type			
	40	10 ... 500	34 488 FENG-40-...-KF	34 482	FENG-40-...		
	63	10 ... 500	34 490 FENG-63-...-KF	34 484	FENG-63-...		
	100	10 ... 500	34 492 FENG-100-...-KF	34 486	FENG-100-...		

Clamping-unit cylinders, standard port pattern

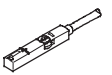
Accessories

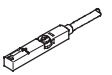

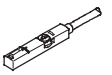
Ordering data – Mounting kits for proximity sensors SMT-8		Technical data → Internet: smb	
	For Ø [mm]	Part No.	Type
	40	175 705	SMB-8-FENG-32/40
	63	175 706	SMB-8-FENG-50/63
	100	175 707	SMB-8-FENG-80/100

Ordering data – Proximity sensors for T-slot, magneto-resistive					Technical data → Internet: smt	
	Type of mounting	Switch output	Electrical connection	Cable length [m]	Part No.	Type
N/O contact						
	Insertable in the slot from above, flush with cylinder profile	PNP	Cable, 3-wire	2.5	543 867	SMT-8M-PS-24V-K-2,5-OE
			Plug M8x1, 3-pin	0.3	543 866	SMT-8M-PS-24V-K-0,3-M8D
			Plug M12x1, 3-pin	0.3	543 869	SMT-8M-PS-24V-K-0,3-M12
		NPN	Cable, 3-wire	2.5	543 870	SMT-8M-NS-24V-K-2,5-OE
Plug M8x1, 3-pin	0.3		543 871	SMT-8M-NS-24V-K-0,3-M8D		
	Insertable in the slot lengthwise, flush with the cylinder profile	PNP	Cable, 3-wire	2.5	175 436	SMT-8-PS-K-LED-24-B
			Plug M8x1, 3-pin	0.3	175 484	SMT-8-PS-S-LED-24-B
N/C contact						
	Insertable in the slot from above, flush with cylinder profile	PNP	Cable, 3-wire	7.5	543 873	SMT-8M-PO-24V-K7,5-OE

Ordering data – Proximity sensors for T-slot, magnetic reed					Technical data → Internet: sme		
	Type of mounting	Switch output	Electrical connection	Cable length [m]	Part No.	Type	
N/O contact							
	Insertable in the slot from above, flush with cylinder profile	Contacting	Cable, 3-wire	2.5	543 862	SME-8M-DS-24V-K-2,5-OE	
				5.0	543 863	SME-8M-DS-24V-K-5,0-OE	
			Plug M8x1, 3-pin	Cable, 3-wire	2.5	543 872	SME-8M-ZS-24V-K-2,5-OE
				Plug M8x1, 3-pin	0.3	543 861	SME-8M-DS-24V-K-0,3-M8D
	Insertable in the slot lengthwise, flush with the cylinder profile	Contacting	Cable, 3-wire	2.5	150 855	SME-8-K-LED-24	
			Plug M8x1, 3-pin	0.3	150 857	SME-8-S-LED-24	
N/C contact							
	Insertable in the slot lengthwise, flush with the cylinder profile	Contacting	Cable, 3-wire	7.5	160 251	SME-8-O-K-LED-24	

Clamping-unit cylinders, standard port pattern

Accessories

Ordering data – Connecting cables				Technical data → Internet: nebu	
	Electrical connection, left	Electrical connection, right	Cable length [m]	Part No.	Type
	Straight socket, M8x1, 3-pin	Cable, open end, 3-wire	2.5	541 333	NEBU-M8G3-K-2.5-LE3
			5	541 334	NEBU-M8G3-K-5-LE3
	Straight socket, M12x1, 5-pin	Cable, open end, 3-wire	2.5	541 363	NEBU-M12G5-K-2.5-LE3
			5	541 364	NEBU-M12G5-K-5-LE3
	Angled socket, M8x1, 3-pin	Cable, open end, 3-wire	2.5	541 338	NEBU-M8W3-K-2.5-LE3
			5	541 341	NEBU-M8W3-K-5-LE3
	Angled socket, M12x1, 5-pin	Cable, open end, 3-wire	2.5	541 367	NEBU-M12W5-K-2.5-LE3
			5	541 370	NEBU-M12W5-K-5-LE3

Ordering data – Slot cover for T-slot			Part No.	Type
	Assembly	Length [m]		
	Insertable from above	2x 0.5	151 680	ABP-5-S

Ordering data – One-way flow control valves				Technical data → Internet: grla	
	Connection		Material	Part No.	Type
	Thread	For tubing OD			
	G1/8	3	Metal design	193 142	GRLA-1/8-QS-3-D
		4		193 143	GRLA-1/8-QS-4-D
		6		193 144	GRLA-1/8-QS-6-D
		8		193 145	GRLA-1/8-QS-8-D
	G1/4	6		193 146	GRLA-1/4-QS-6-D
		8		193 147	GRLA-1/4-QS-8-D
		10		193 148	GRLA-1/4-QS-10-D
	G3/8	6		193 149	GRLA-3/8-QS-6-D
		8		193 150	GRLA-3/8-QS-8-D
		10		193 151	GRLA-3/8-QS-10-D
	G1/2	12		193 152	GRLA-1/2-QS-12-D