

Electric cylinders DNCE-LAS, with linear motor



# Electric cylinders DNCE-LAS, with linear motor

Key features

## At a glance

### Characteristics

- Linear motor axis with piston rod
- The electric cylinder consists of a freely positionable linear motor, integrated displacement encoder with magnetic strip, reference switch and plain bearings
- Enables positioning with very high dynamic response. Accelerations of up to 125 m/s<sup>2</sup> are possible without load
- Mechanical interfaces are largely compatible with the standard cylinder DNC

### Range of applications

- Positioning of small loads such as:
  - placing small parts into and removing small parts from magazines
  - sorting parts quickly
  - for equipping and assembly processes

## Everything from a single source

Electric cylinder DNCE-LAS

→ 3



Motor controller SFC-LACI

→ Internet: sfc-laci

The electric cylinder DNCE-LAS and motor controller SFC-LACI form one unit.

- Thanks to protection class IP54, the SFC can be mounted close to the DNCE, either:
    - via central supports or
    - via H-rail
  - Just two cables are required between the electric cylinder DNCE and motor controller SFC (motor and encoder cable)
  - The motor controller SFC is available with or without control panel
  - Up to 31 positioning records
- Parameterisation via:
- Control panel:
    - suitable for simple position sequences

Parameterisation via:

- FCT (Festo Configuration Tool) configuration package:
  - via RS 232 interface
  - Windows-based PC user interface, Festo Configuration Tool
- Easy actuation via:
  - I/O interface
  - Profibus
  - CANopen, incl. “interpolated position mode”
  - DeviceNet



## Optional: Electric cylinder DNCE-LAS with clamping unit



The pneumatically actuated clamping unit can be used to hold loads in any stroke position and with the module installed in any position. Clamping in the end positions is not permitted. In the case of a pressure drop or pressure failure, the clamping unit acts like an EMERGENCY STOP device. The clamping unit can be released by means of the manual override.

# Electric cylinders DNCE-LAS, with linear motor

Type codes

		DNCE	32	100	LAS	F	C	S1
<b>Type</b>								
DNCE	Electric cylinder							
<b>Size</b>								
<b>Stroke [mm]</b>								
<b>Drive type/motor technology</b>								
LAS	Linear motor, AC synchronous							
<b>Cable outlet direction</b>								
H	To the rear							
F	To the front							
L	To the left							
R	To the right							
<b>Clamping unit</b>								
C	Attached							
<b>Protection class for electrics</b>								
S1	IP65							

## Cable outlet direction

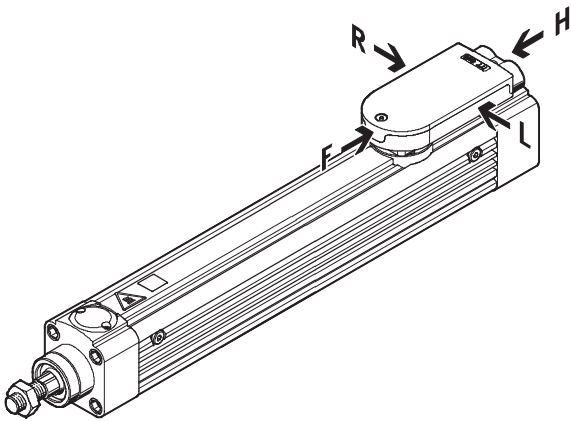

## Instructions for use

The electric cylinder with linear motor is not designed for the following sample applications:

- Magnetic field

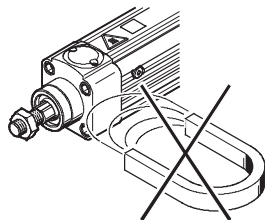

- Welding application

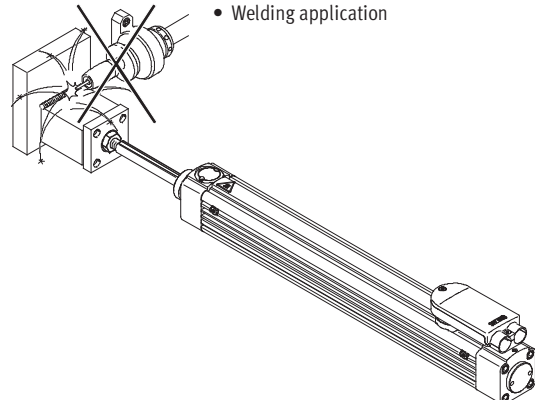

# Electric cylinders DNCE-LAS, with linear motor

Peripherals overview

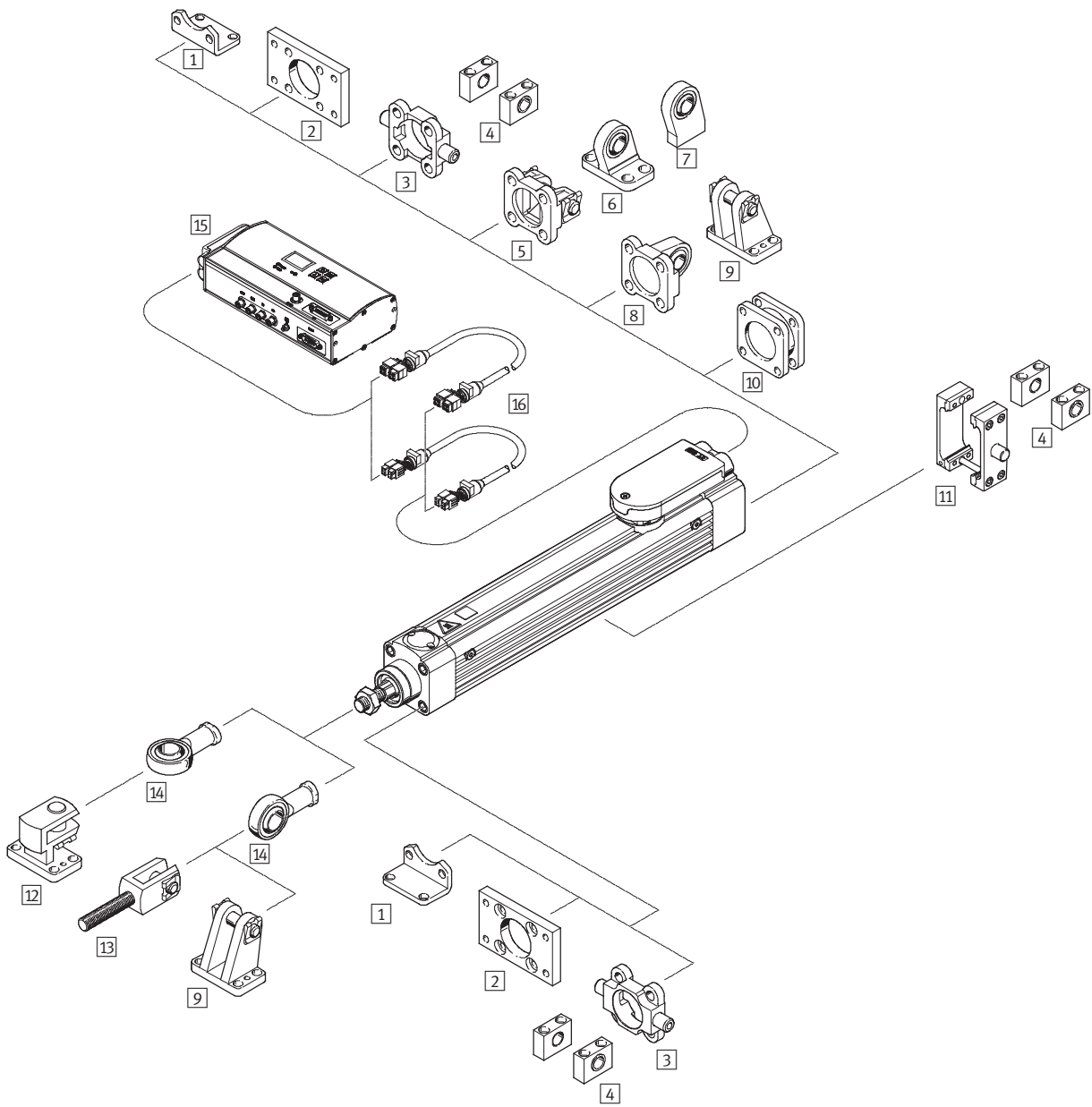

## Electric cylinders DNCE-LAS, with linear motor

Peripherals overview

FESTO

Mounting attachments and accessories		
	Brief description	→ Page/Internet
1	Foot mounting HNC/CRHNC	For bearing or end caps 17
2	Flange mounting FNC/CRFNG	For bearing or end caps 18
3	Trunnion flange ZNC/CRZNG	For bearing or end caps 19
4	Trunnion support LNZG/CRLNZG	For cylinders with trunnion mounting 20
5	Swivel flange SNC	For end caps 21
6	Clevis foot LSNG	With spherical bearing 22
7	Clevis foot LSNSG	Weld-on, with spherical bearing 22
8	Swivel flange SNCS	For end caps, with spherical bearing 21
9	Clevis foot LBG	With non-rotating pivot pin 22
10	Multi-position kit DPNC	For connecting two cylinders of the same size to form a multi-position cylinder 19
11	Trunnion mounting kit ZNCM	For mounting anywhere along the cylinder profile barrel 22
12	Right-angle clevis foot LQG	For rod eye SGS 22
13	Rod clevis SGA	For swivel attachment of cylinders 22
14	Rod eye SGS	With spherical bearing 22
15	Motor controller SFC-LACI	For parameterising and positioning the electric cylinder sfc-laci
16	Motor/encoder cable NEBM	For connecting the motor and controller sfc-laci

# Electric cylinders DNCE-LAS, with linear motor

Technical data

Function

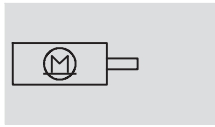

 Size  
32, 40

 Stroke length  
100 ... 400 mm

 Note

All values are based on a standard temperature of 23 °C. Dynamic response and accuracy are dependent on the mounting (rigidity) and temperature stresses (heat concentration).

 [www.festo.com](http://www.festo.com)



General technical data								
Size		32			40			
Stroke	[mm]	100	200	320	100	200	320	400
Mechanical								
Design		Electric linear direct drive						
Drive unit operating mode		Piston rod						
Type of mounting		Via female thread						
		Via accessories						
Mounting position		Any						
Continuous feed force <sup>1)</sup>	[N]	33.7	29.4	33.8	55.3	33.8	42.1	47.9
Peak feed force <sup>1)</sup>	[N]	93.7	141	141	183	202	202	202
Max. effective load without external guide (horizontal operation)	[kg]	1.5	1	0.5	2.5	2.5	1.5	1.4
Max. effective load with external guide (horizontal operation)	[kg]	2.8	6	4	3.4	6	6	6
Max. effective load without external guide (vertical operation)	[kg]	3	3	2	3	3	3	3
Max. speed	[m/s]	2	3	3	2	3	3	3
Repetition accuracy	[mm]	±0.02						
Electric								
Type of motor		Linear AC servo motor						
Displacement encoder		Relative measurement, magnetic, incremental, contactless						
Peak motor current	[A]	5.9	16.2	16.2	7.65	22.5	22.5	22.5
Nominal motor current	[A]	2.1	3.3	3.9	2.25	3.7	4.6	5.2
Rated motor output	[W]	101	88	101	166	101	126	144
Homing		Integrated reference sensor						

1) Disregarding friction

Technical data – Clamping unit								
Size		32			40			
Stroke	[mm]	100	200	320	100	200	320	400
Design		Spring-loaded clamping profile						
Pneumatic connection		M5			G1/8			
Min. release pressure	[bar]	3						
Max. operating pressure	[bar]	8						
Operating medium		Dried compressed air, lubricated or unlubricated						
Max. static holding force	[N]	600			1,000			
Max. effective load (vertical operation)	[kg]	1.5	1.5	1	1.5	1.5	1.5	1.5
Max. axial backlash with clamped piston rod without load	[mm]	0.5						

# Electric cylinders DNCE-LAS, with linear motor

Technical data

Operating and environmental conditions	
Ambient temperature [°C]	0 ... +40
Max. motor temperature [°C]	70 (warning at 70 °C, shut-off at 75 °C)
Standard temperature <sup>1)</sup> [°C]	23
Temperature monitoring	Shuts off if motor overheats
Protection class (mechanical system)	IP40
Protection class (electrical connection)	IP40 (with DNCE-...-S1: IP65)
CE marking (see declaration of conformity)	To EU EMC Directive
Corrosion resistance class CRC <sup>2)</sup>	1

1) Unless otherwise stated, all values are based on standard temperature

2) Corrosion resistance class 1 according to Festo standard 940 070

Components subject to low corrosion stress. Transport and storage protection. Parts that do not have primarily decorative surface requirements, e.g. in internal areas that are not visible or behind covers

Weight [g]							
Size	32			40			
Stroke [mm]	100	200	320	100	200	320	400
Product weight	2,570	3,170	3,750	4,560	5,420	6,420	7,000
Moving load	530	610	710	1,340	1,470	1,630	1,750

## Materials

Sectional view

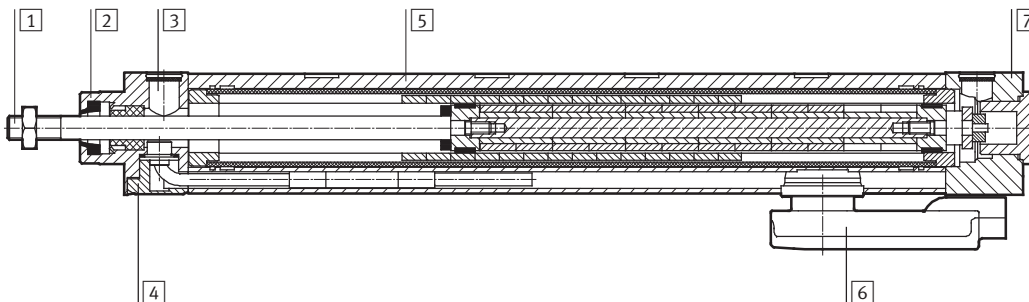

Electric cylinder		
1	Piston rod	High-alloy stainless steel
2	Bearing cap	Anodised wrought aluminium alloy
3	Filter disc	Sintered bronze
4	Distance piece	Anodised wrought aluminium alloy
5	Cylinder barrel	Anodised wrought aluminium alloy
6	Terminal strip	Die-cast zinc
7	End cap	Anodised wrought aluminium alloy
-	Screws	Galvanised steel
Note on materials		Contains PWIS (paint-wetting impairment substances)
		RoHS-compliant

# Electric cylinders DNCE-LAS, with linear motor

Technical data

## Maximum permissible loads on the piston rod

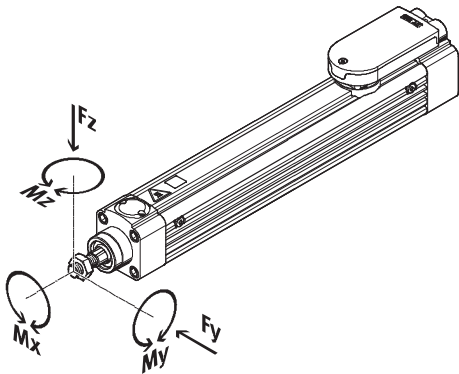

If there are two or more forces and torques simultaneously acting upon the piston rod, the following equations must be satisfied:

$$\frac{|F_{y1}|}{F_{y_{max}}} + \frac{|F_{z1}|}{F_{z_{max}}} + \frac{|M_{y1}|}{M_{y_{max}}} + \frac{|M_{z1}|}{M_{z_{max}}} \leq 1$$

## Maximum permissible lateral forces $F_{y_{max}}$ and $F_{z_{max}}$ as a function of stroke $l$ (limited by the plain bearing)

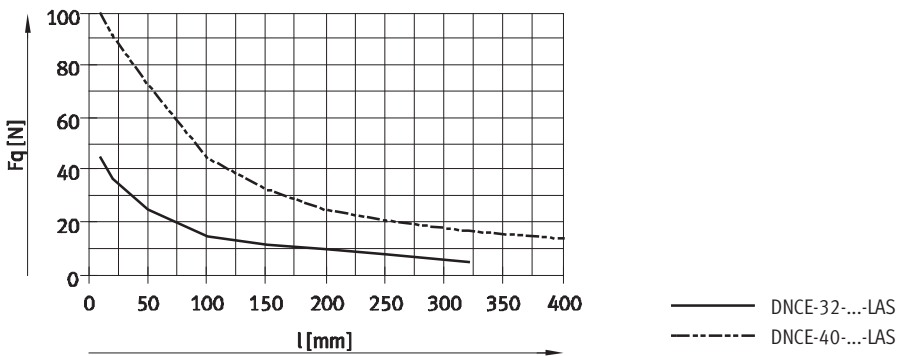

## Maximum permissible forces and torques

Size	32	40
$M_{x_{max}}$ [Nm]	No torques are permitted	
$M_{y_{max}}, M_{z_{max}}$ [Nm]	2	5

 Note

PositioningDrives  
sizing software  
→ [www.festo.com](http://www.festo.com)

## Stroke reserve and cushioning length

### 1 Working stroke:

The recommended, available operating range

L12, L13 Stroke reserve:

The distance from the end positions of the working stroke to the buffers

L11 Cushioning length:

The distance from the buffer surface to the mechanical end position

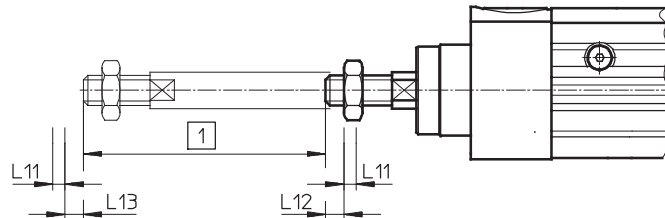

Size	Retracted		Advanced	
	L12	L11	L13	L11
32 [mm]	3.3	2	5.9	2
40 [mm]	3.1	2	3.7	2



# Electric cylinders DNCE-LAS, with linear motor

Technical data

Piston rod displacement  $f$ , with fully advanced piston rod, as a function of lateral force  $F_q$

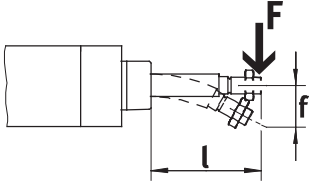

Mounting position

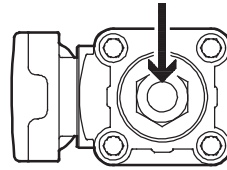
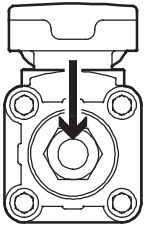

DNCE-32

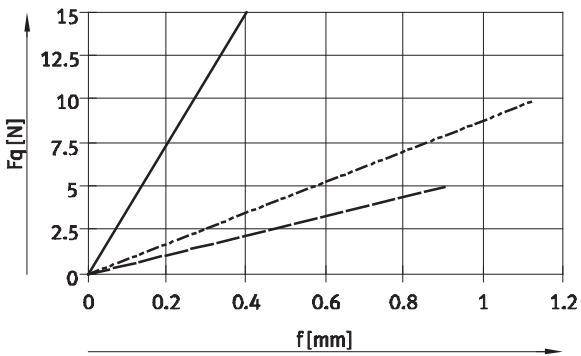

- DNCE-32-100-LAS
- - - DNCE-32-200-LAS
- · - DNCE-32-320-LAS

DNCE-32

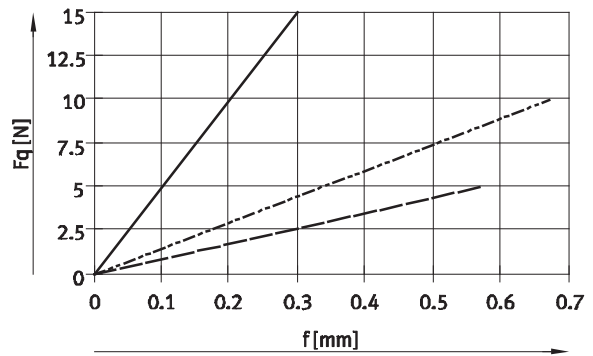

- DNCE-32-100-LAS
- - - DNCE-32-200-LAS
- · - DNCE-32-320-LAS

DNCE-40

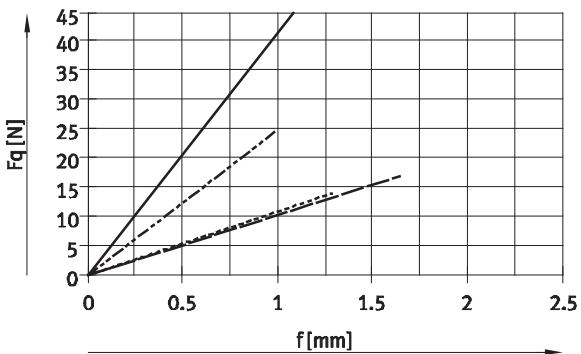

- DNCE-40-100-LAS
- - - DNCE-40-200-LAS
- · - DNCE-40-320-LAS
- · · - DNCE-40-400-LAS

DNCE-40

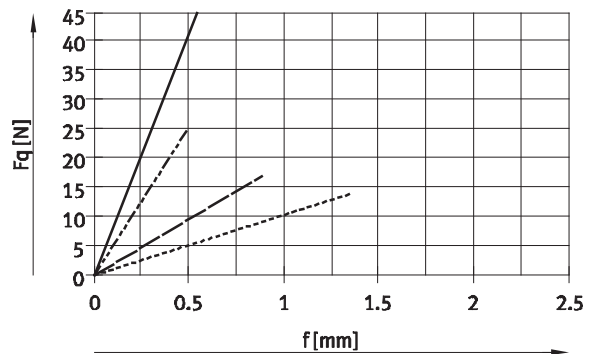

- DNCE-40-100-LAS
- - - DNCE-40-200-LAS
- · - DNCE-40-320-LAS
- · · - DNCE-40-400-LAS

# Electric cylinders DNCE-LAS, with linear motor

Technical data

## Positioning time $t$ as a function of stroke $l$ , effective load $M$ and duty cycle ED For horizontal mounting position

DNCE-32-100

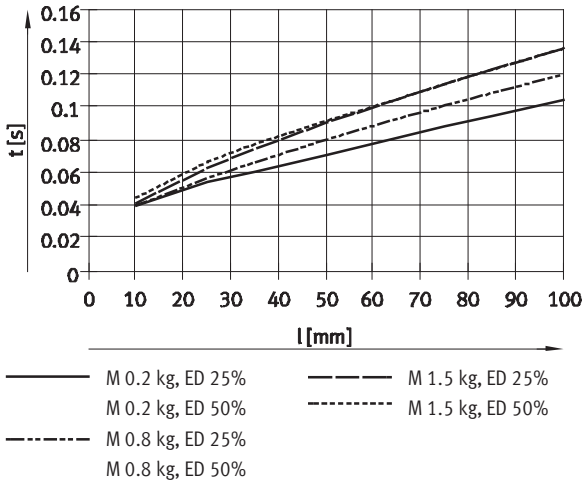

DNCE-32-200

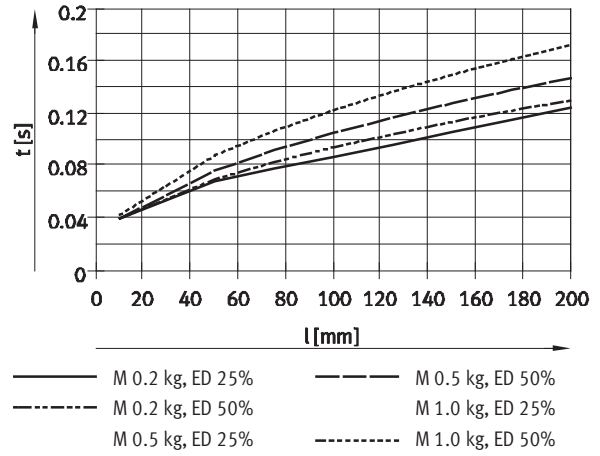

DNCE-32-320

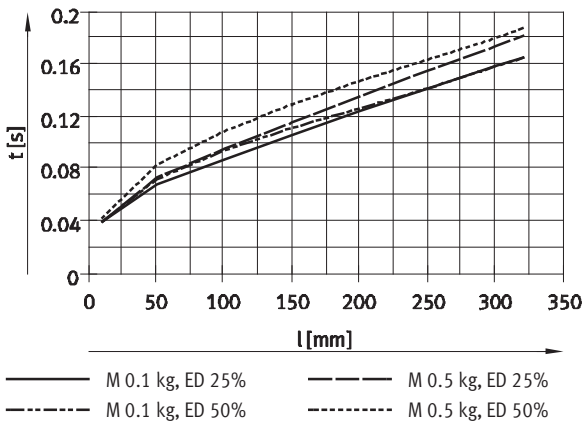

DNCE-40-100

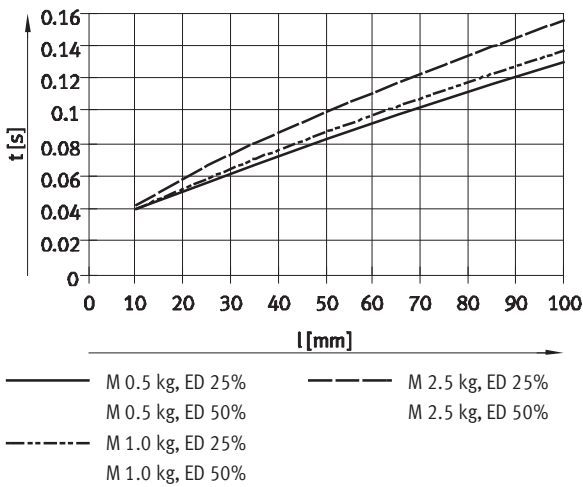

DNCE-40-200

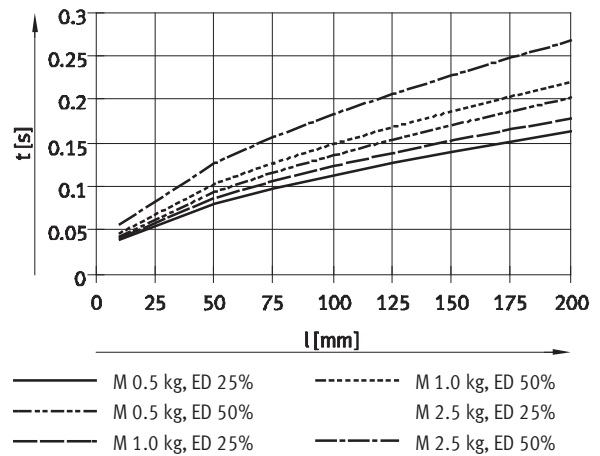

# Electric cylinders DNCE-LAS, with linear motor

Technical data

FESTO

## Positioning time $t$ as a function of stroke $l$ , effective load $M$ and duty cycle ED For horizontal mounting position

DNCE-40-320

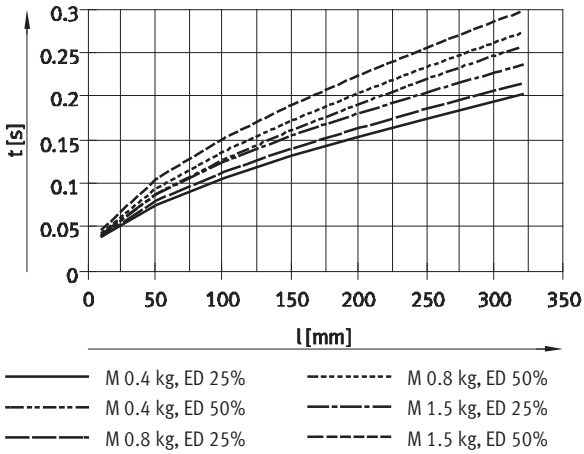

DNCE-40-400

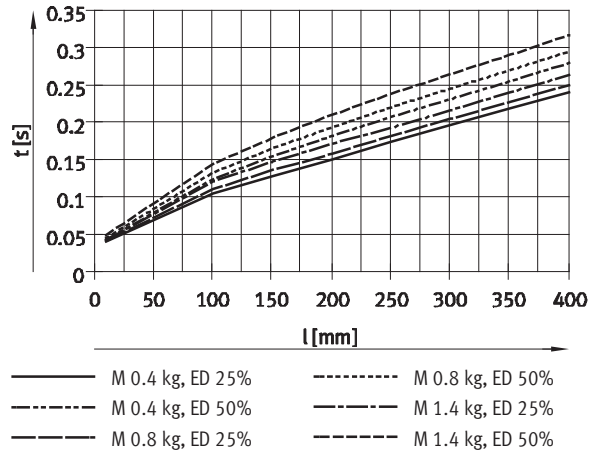

## Feed force $F$ as a function of stroke $l$

The graphs are based on practical values with friction taken into account.

Peak feed force

Continuous feed force at ambient temperature:

- from 23 °C
- from 30 °C
- from 40 °C

DNCE-32-100

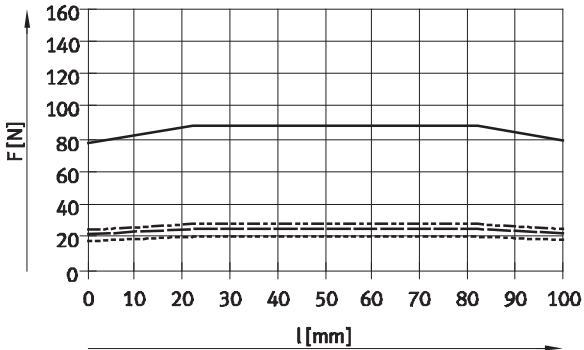

DNCE-32-200

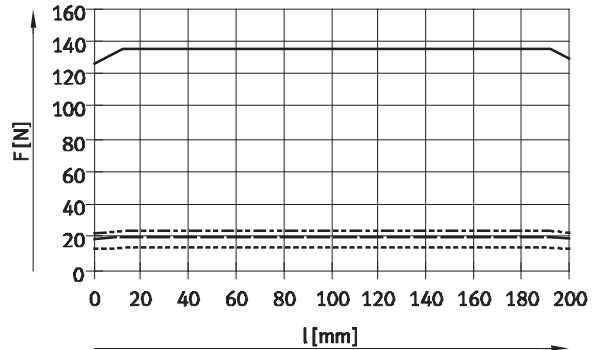

DNCE-32-320

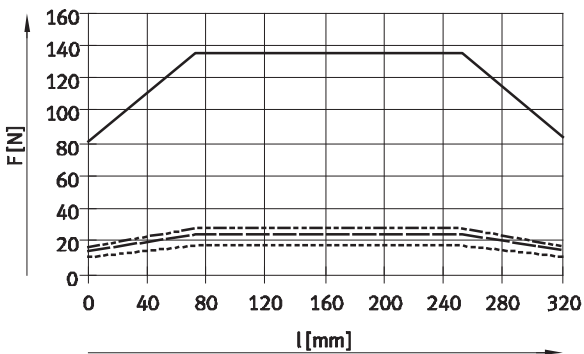

# Electric cylinders DNCE-LAS, with linear motor

Technical data

## Feed force F as a function of stroke l

The graphs are based on practical values with friction taken into account.

Peak feed force



Continuous feed force at ambient temperature:

----- from 23 °C

----- from 30 °C

----- from 40 °C

DNCE-40-100

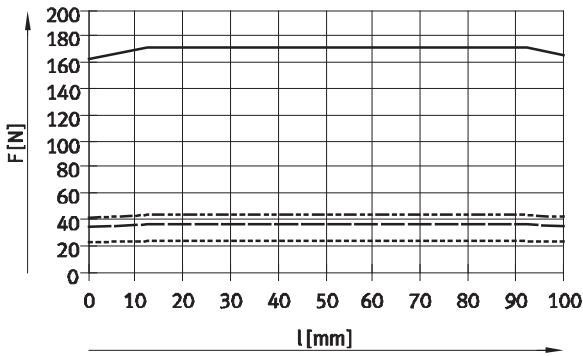

DNCE-40-200

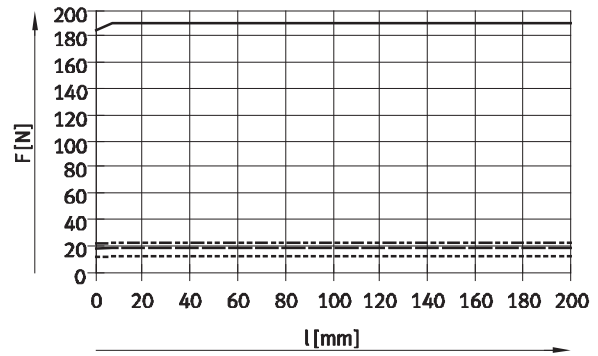

DNCE-40-320

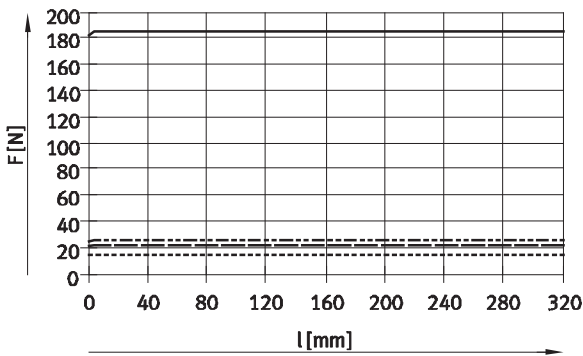

DNCE-40-400

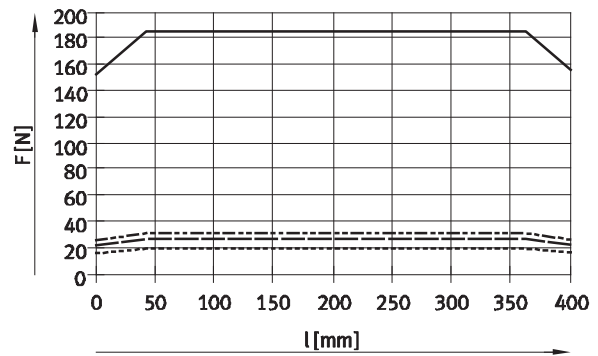

# Electric cylinders DNCE-LAS, with linear motor

Technical data

## Feed force F as a function of speed v

The graphs are based on practical values under the following conditions:

- Stroke centre of the electric cylinder
- Friction taken into account
- Standard temperature of 23 °C
- Max. motor temperature of 70 °C

Legend:

- Peak feed force (light grey shaded area)
- Continuous feed force (dark grey shaded area)
- Non-permissible range (dashed line)

DNCE-32-100

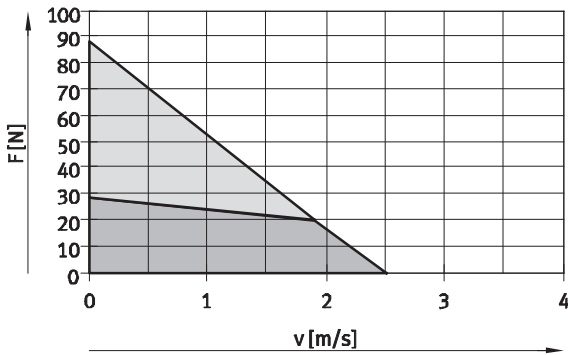

DNCE-32-200

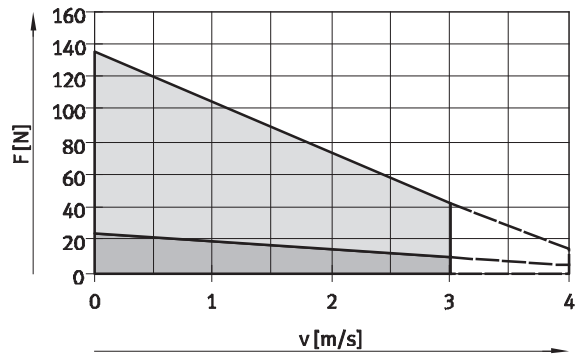

DNCE-32-320

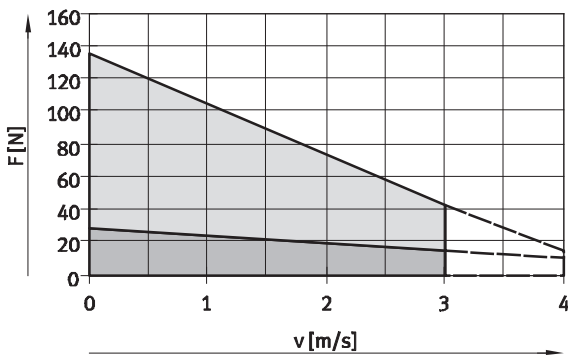

DNCE-40-100

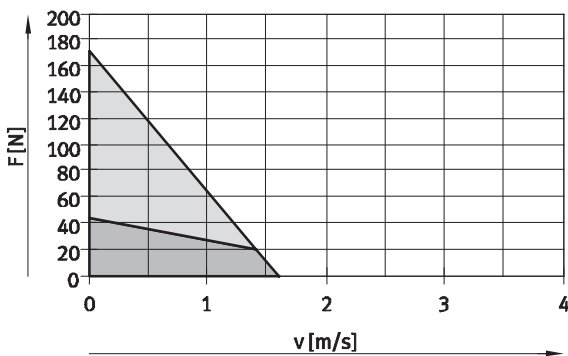

DNCE-40-200

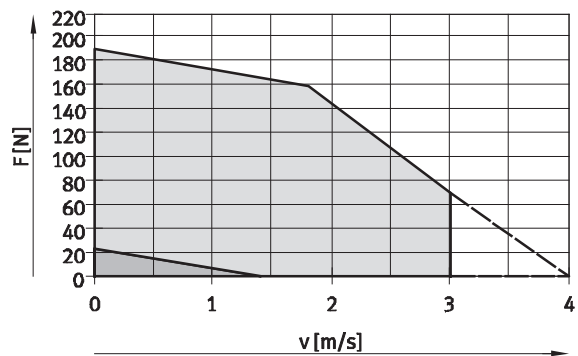

DNCE-40-320

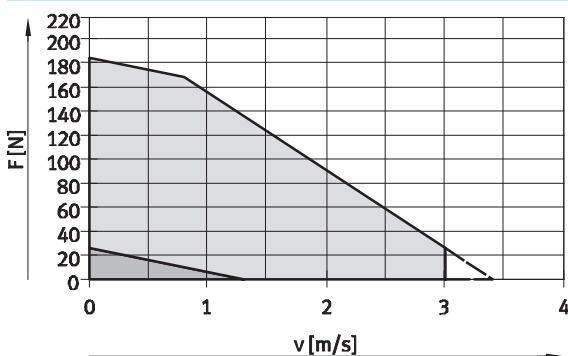

DNCE-40-400

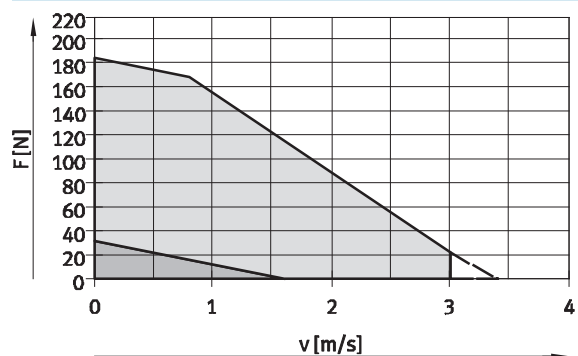

# Electric cylinders DNCE-LAS, with linear motor

Technical data

**Dimensions**

Download CAD data → [www.festo.com](http://www.festo.com)

DNCE-...

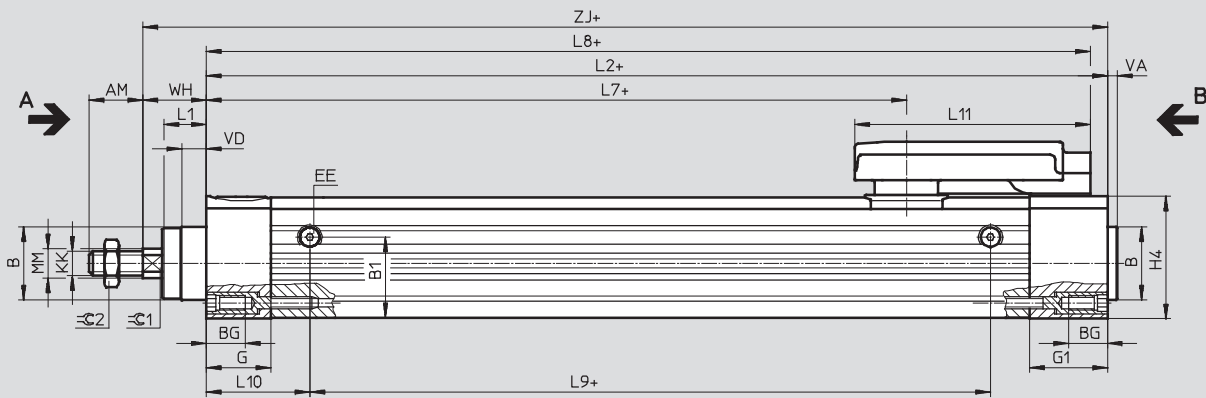

**View A**

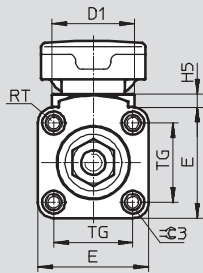

**View B**

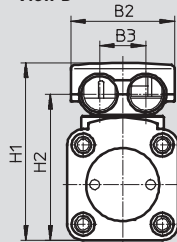

+ = plus stroke length

Size	AM	B ∅ d11	B1	B2	B3	BG	D1 ∅	E	EE	G	G1
32	22	30	33	42.6	19	16	34	45.5	M5	26.5	32
40	24	35	38	42.6	19	16	34	54	M5	26.5	32

Size	H1	H2	H4	H5	KK	L1	L2	L7	L8	L9	L10
32	72.8	59.8	50.3	5.5	M10X1.25	18	270	187.5	263	179.5	42.5
40	81.3	68.3	58.7	5.5	M12X1.25	21.3	341	258.5	334	240.5	47.5

Size	L11	MM ∅	RT	TG	VA	VD	WH	ZJ	∅C1	∅C2	∅C3
32	96.8	12	M6	32.5	4	10	26 <sub>-3,3</sub>	296 <sub>-3,3</sub>	10	17	6
40	96.8	16	M6	38	4	10.3	30 <sub>-3,1</sub>	371 <sub>-3,1</sub>	13	19	6

# Electric cylinders DNCE-LAS, with linear motor

Technical data

**Dimensions**

Download CAD data → [www.festo.com](http://www.festo.com)

DNCE-...C – With clamping unit

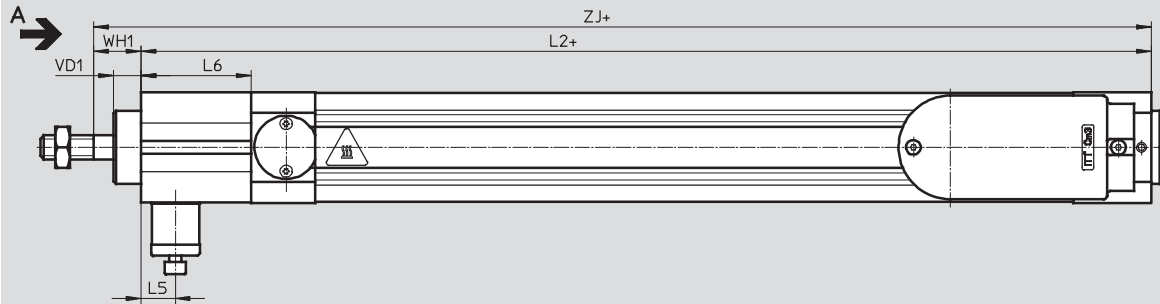

View A

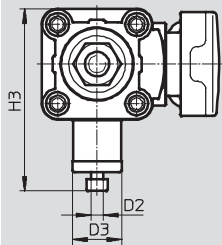

+ = plus stroke length

Size	D2	D3 ∅	H3	L2	L5	L6	VD1	WH1	ZJ
32	M5	20	67.3	315	14	45	11.5	19.5-3.3	334.5-3.3
40	G1/8	24	88	394	16	53	11.5	20-3.1	414-3.1

## Electric cylinders DNCE-LAS, with linear motor

Ordering data – Modular products

Ordering table					
Size	32	40	Condi- tions	Code	Enter code
<b>M</b> Module No.	<b>562830</b>	<b>562831</b>			
Function	Electric cylinder			<b>DNCE</b>	DNCE
Size	32	40		-...	
Stroke [mm]	100	100		-...	
	200	200			
	320	320			
	-	400			
Drive type	Linear motor			<b>-L</b>	-L
Motor technology	AC synchronous			<b>AS</b>	AS
Cable outlet direction	To the rear			<b>-H</b>	
	To the front			<b>-F</b>	
	To the left			<b>-L</b>	
	To the right			<b>-R</b>	
<b>O</b> Clamping unit	Attached			<b>-C</b>	
Protection class for electrics	IP65			<b>-S1</b>	

Transfer order code



# Electric cylinders DNCE-LAS, with linear motor

Accessories

**FESTO**

## Foot mounting HNC/CRHNC

Material:  
 HNC: Galvanised steel  
 CRHNC: High-alloy steel  
 Free of copper, PTFE and silicone

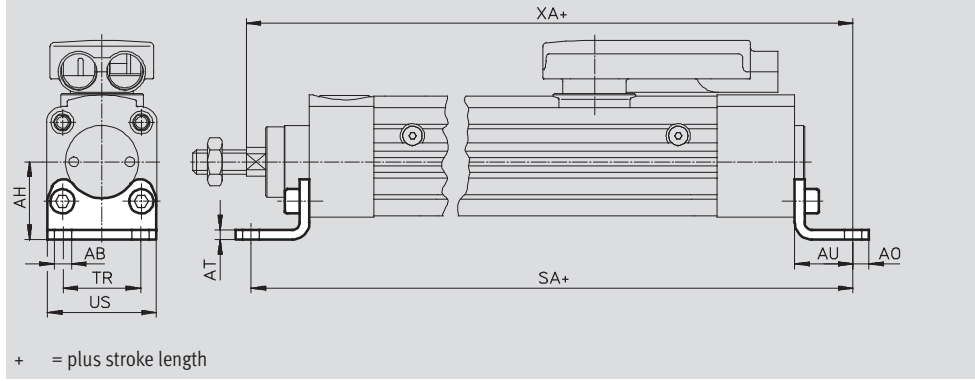

Dimensions and ordering data											
For size	AB ∅	AH	AO	AT	AU	SA		TR	US	XA	
[mm]							-C				-C
32	7	32	6.5	4	24	318	363	32	45	320	358.5
40	10	36	9	4	28	397	450	36	54	399	442

For size [mm]	Basic version				High corrosion protection			
	CRC <sup>1)</sup>	Weight [g]	Part No.	Type	CRC <sup>1)</sup>	Weight [g]	Part No.	Type
32	2	144	<b>174369</b>	<b>HNC-32</b>	4	139	<b>176937</b>	<b>CRHNC-32</b>
40	2	193	<b>17470</b>	<b>HNC-40</b>	4	188	<b>176938</b>	<b>CRHNC-40</b>

1) Corrosion resistance class 2 according to Festo standard 940 070  
 Components subject to moderate corrosion stress. Externally visible parts with primarily decorative surface requirements which are in direct contact with a normal industrial environment or media such as coolants or lubricating agents  
 Corrosion resistance class 4 according to Festo standard 940 070  
 Components subject to particularly high corrosion stress. Parts used with aggressive media, e.g. in the food or chemical industry. These applications should be supported with special tests with the media if required

# Electric cylinders DNCE-LAS, with linear motor

Accessories

**Flange mounting FNC/CRFNG**

Material:  
 FNC: Galvanised steel  
 CRFNG: High-alloy steel  
 Free of copper, PTFE and silicone

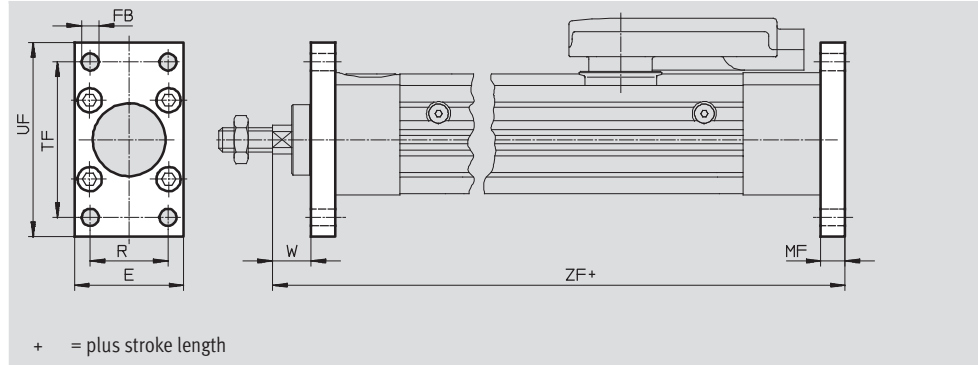

Dimensions and ordering data										
For size	E	FB	MF	R	TF	UF	W		ZF	
[mm]		∅ H13						-C		-C
32	45	7	10	32	64	80	16	9.5	306	344.5
40	54	9	10	36	72	90	20	10	381	424

For size	Basic version				High corrosion protection			
	CRC <sup>1)</sup>	Weight [g]	Part No.	Type	CRC <sup>1)</sup>	Weight [g]	Part No.	Type
[mm]								
32	2	240	<b>174376</b>	<b>FNC-32</b>	4	240	<b>161846</b>	<b>CRFNG-32</b>
40	2	280	<b>174377</b>	<b>FNC-40</b>	4	300	<b>161847</b>	<b>CRFNG-40</b>

1) Corrosion resistance class 2 according to Festo standard 940 070  
 Components subject to moderate corrosion stress. Externally visible parts with primarily decorative surface requirements which are in direct contact with a normal industrial environment or media such as coolants or lubricating agents  
 Corrosion resistance class 4 according to Festo standard 940 070  
 Components subject to particularly high corrosion stress. Parts used with aggressive media, e.g. in the food or chemical industry. These applications should be supported with special tests with the media if required

# Electric cylinders DNCE-LAS, with linear motor

Accessories

## Trunnion flange ZNCF/CRZNG

Material:  
 ZNCF: Stainless steel casting  
 CRZNG: Electropolished special steel casting  
 Free of copper, PTFE and silicone

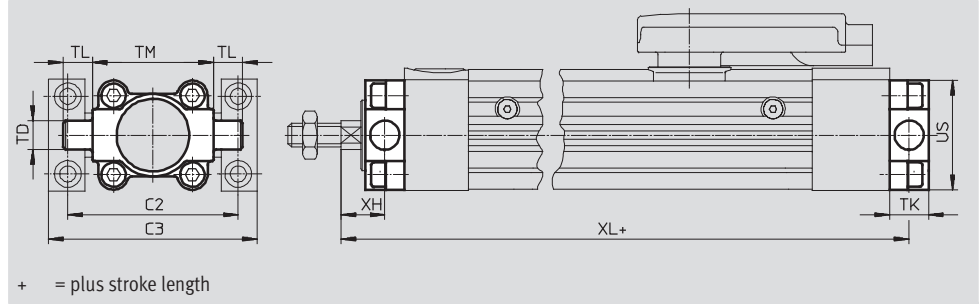

Dimensions and ordering data											
For size	C2	C3	TD	TK	TL	TM	US	XH		XL	
[mm]			∅ e9						-C		-C
32	71	86	12	16	12	50	45	18	11.5	304	342.5
40	87	105	16	20	16	63	54	20	10	381	424

For size	Basic version				High corrosion protection			
	CRC <sup>1)</sup>	Weight [g]	Part No.	Type	CRC <sup>1)</sup>	Weight [g]	Part No.	Type
32	2	150	<b>174411</b>	<b>ZNCF-32</b>	4	150	<b>161852</b>	<b>CRZNG-32</b>
40	2	285	<b>174412</b>	<b>ZNCF-40</b>	4	285	<b>161853</b>	<b>CRZNG-40</b>

1) Corrosion resistance class 2 according to Festo standard 940 070  
 Components subject to moderate corrosion stress. Externally visible parts with primarily decorative surface requirements which are in direct contact with a normal industrial environment or media such as coolants or lubricating agents  
 Corrosion resistance class 4 according to Festo standard 940 070  
 Components subject to particularly high corrosion stress. Parts used with aggressive media, e.g. in the food or chemical industry. These applications should be supported with special tests with the media if required

## Multi-position kit DPNC

Material:  
 Flange: Wrought aluminium alloy  
 Threaded studs, hex nuts:  
 Galvanised steel

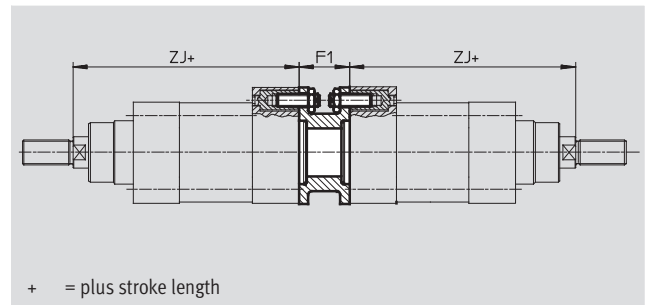
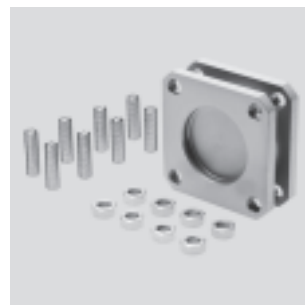

Dimensions and ordering data						
For size	F1	ZJ		Weight [g]	Part No.	Type
			-C			
32	27	296	334.5	85	<b>174418</b>	<b>DPNC-32</b>
40	27	371	414	115	<b>174419</b>	<b>DPNC-40</b>

# Electric cylinders DNCE-LAS, with linear motor

Accessories

## Trunnion support LNZG

Material:  
Trunnion support:  
Anodised aluminium  
Plain bearing: Plastic  
Free of copper, PTFE and silicone

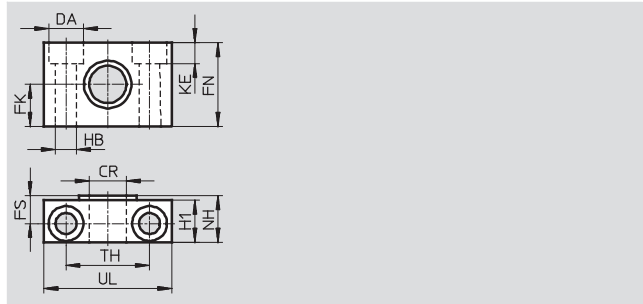

Dimensions and ordering data															
For size	CR	DA	FK	FN	FS	H1	HB	KE	NH	TH	UL	CRC <sup>1)</sup>	Weight	Part No.	Type
[mm]	∅	∅	∅				∅			±0.2			[g]		
32	12	11	15	30	10.5	15	6.6	6.8	18	32	46	2	125	<b>32959</b>	<b>LNZG-32</b>
40	16	15	18	36	12	18	9	9	21	36	55	2	400	<b>32960</b>	<b>LNZG-40/50</b>

## Trunnion support CRLNZG

Material:  
High-alloy steel  
Free of copper, PTFE and silicone

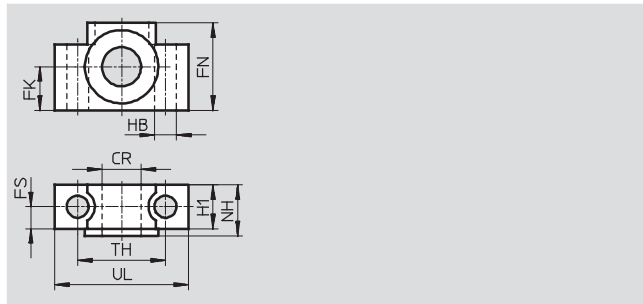
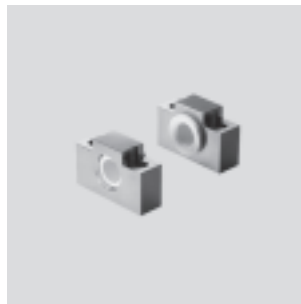

Dimensions and ordering data															
For size	CR	FK	FN	FS	H1	HB	NH	TH	UL	CRC <sup>1)</sup>	Weight	Part No.	Type		
[mm]	∅	∅				∅		±0.2			[g]				
32	12	15	30	10.5	15	6.6	18	32	46	4	200	<b>161874</b>	<b>CRLNZG-32</b>		
40	16	18	36	12	18	9	21	36	55	4	330	<b>161875</b>	<b>CRLNZG-40/50</b>		

1) Corrosion resistance class 2 according to Festo standard 940 070  
 Components subject to moderate corrosion stress. Externally visible parts with primarily decorative surface requirements which are in direct contact with a normal industrial environment or media such as coolants or lubricating agents  
 Corrosion resistance class 4 according to Festo standard 940 070  
 Components subject to particularly high corrosion stress. Parts used with aggressive media, e.g. in the food or chemical industry. These applications should be supported with special tests with the media if required

# Electric cylinders DNCE-LAS, with linear motor

Accessories

**FESTO**

## Swivel flange SNC

Material:

Die-cast aluminium

Free of copper, PTFE and silicone

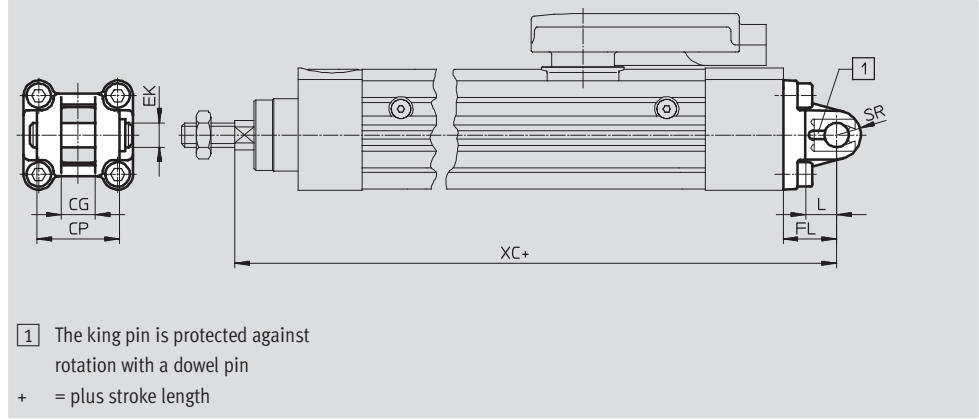

Dimensions and ordering data												
For size	CG	CP	EK	FL	L	SR	XC		CRC <sup>1)</sup>	Weight	Part No.	Type
[mm]	H14	h14	∅	±0.2				-C		[g]		
32	14	34	10	22	13	10	318	356.5	2	90	<b>174383</b>	<b>SNC-32</b>
40	16	40	12	25	16	12	396	439	2	120	<b>174384</b>	<b>SNC-40</b>

## Swivel flange SNCS

Material:

Die-cast aluminium

Free of copper, PTFE and silicone

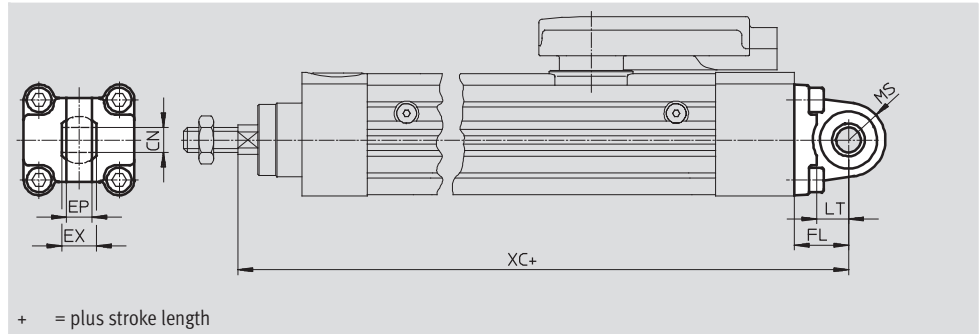
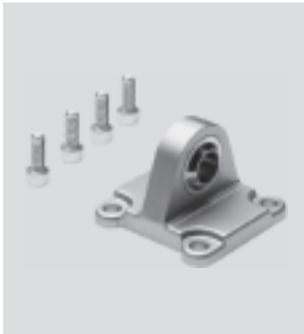

Dimensions and ordering data												
For size	CN	EP	EX	FL	LT	MS	XC		CRC <sup>1)</sup>	Weight	Part No.	Type
[mm]	∅	H7		±0.2				-C		[g]		
32	10	10.5	14	22	13	15	318	356.5	2	85	<b>174397</b>	<b>SNCS-32</b>
40	12	12	16	25	16	17	396	439	2	125	<b>174398</b>	<b>SNCS-40</b>

1) Corrosion resistance class 2 according to Festo standard 940 070  
Components subject to moderate corrosion stress. Externally visible parts with primarily decorative surface requirements which are in direct contact with a normal industrial environment or media such as coolants or lubricating agents

# Electric cylinders DNCE-LAS, with linear motor

Accessories

## Trunnion mounting kit ZNCM

Material:  
Tempered steel

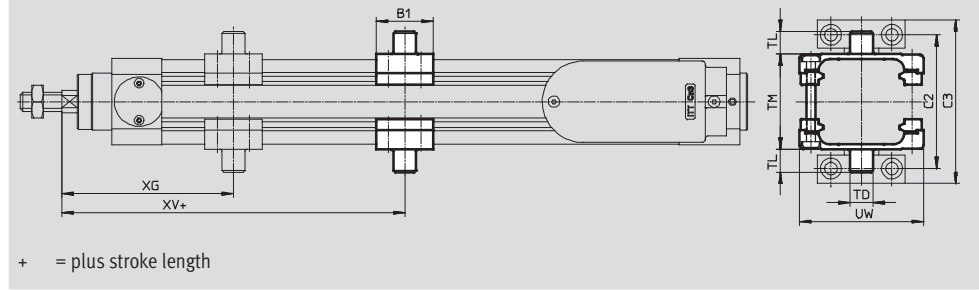

+ = plus stroke length

 **Note**

The kit can be mounted axially anywhere on the cylinder barrel between the positions XG and XV+stroke.

The kit can only be mounted as shown in the drawing and not turned by 90°. The bolt on the top side must be removed for attachment.

### Dimensions and ordering data

For size	B1	C2	C3	TD ∅	TL	TM	UW	XG	XV
[mm]				e9					
32	30	71	86	12	12	50	65	90	80
40	32	87	105	16	16	63	75	100	150



For size	Max. tightening torque	CRC <sup>1)</sup>	Weight	Part No.	Type
[mm]	[Nm]		[g]		
32	4+1	2	210	<b>163525</b>	<b>ZNCM-32</b>
40	8+1	2	385	<b>163526</b>	<b>ZNCM-40</b>

1) Corrosion resistance class 2 according to Festo standard 940 070

Components subject to moderate corrosion stress. Externally visible parts with primarily decorative surface requirements which are in direct contact with a normal industrial environment or media such as coolants or lubricating agents

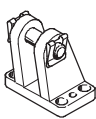
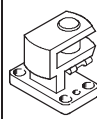

### Ordering data – Mounting attachments

Technical data → Internet: clevis foot

Designation	For size	Part No.	Type	Designation	For size	Part No.	Type
<b>Clevis foot LSNG</b>				<b>Clevis foot LSNSG</b>			
	32	<b>31740</b>	<b>LSNG-32</b>		32	<b>31747</b>	<b>LSNSG-32</b>
	40	<b>31741</b>	<b>LSNG-40</b>		40	<b>31748</b>	<b>LSNSG-40</b>
<b>Clevis foot LBG</b>				<b>Right-angle clevis foot LQG</b>			
	32	<b>31761</b>	<b>LBG-32</b>		32	<b>31768</b>	<b>LQG-32</b>
	40	<b>31762</b>	<b>LBG-40</b>		40	<b>31769</b>	<b>LQG-40</b>

### Ordering data – Piston rod attachments

Technical data → Internet: piston rod attachments

Designation	For size	Part No.	Type	Designation	For size	Part No.	Type
<b>Rod eye SGS</b>				<b>Rod clevis SGA</b>			
	32	<b>9261</b>	<b>SGS-M10x1,25</b>		32	<b>32954</b>	<b>SGA-M10x1,25</b>
	40	<b>9262</b>	<b>SGS-M12x1,25</b>		40	<b>10767</b>	<b>SGA-M12x1,25</b>