

Mini slides DGSC



Mini slides DGSC

Key features

At a glance

Properties

- Smallest guided slide unit (width 8 mm), therefore high component density possible
- Precision ball bearing cage guide permits accurate linearity/parallelism
- Long service life thanks to housing made from high-alloy steel
- Low break-away pressure and uniform movement thanks to minimal friction from guide and seal
- Contact resistance < 5 Ω
- Quick and easy assembly and commissioning

Range of applications

- Two variants available to order:
 - Mounting interface on the side, supply ports on the front
 - Mounting interface on the front, supply ports on the side
- Chip picking
- Slide or separating applications
- Pushing or stem applications

Mounting options

On the housing

DGSC-6-10-P-L

DGSC-6-10-P-P

On the slide

DGSC-6-10-P-...

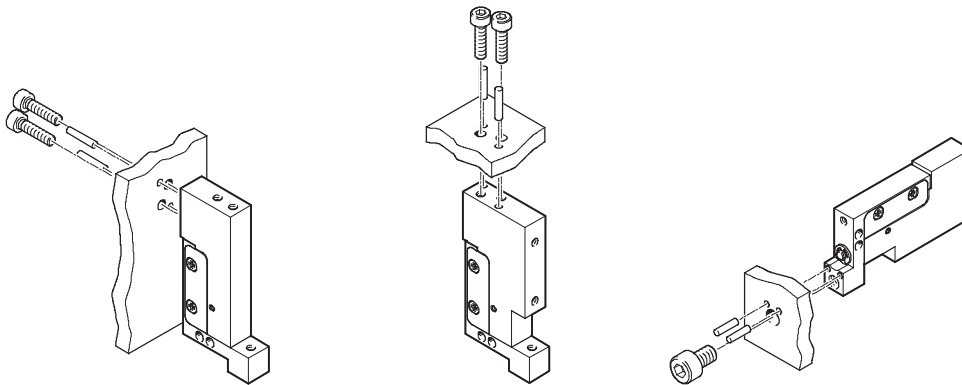

Pneumatic connection

DGSC-6-10-P-L

DGSC-6-10-P-P

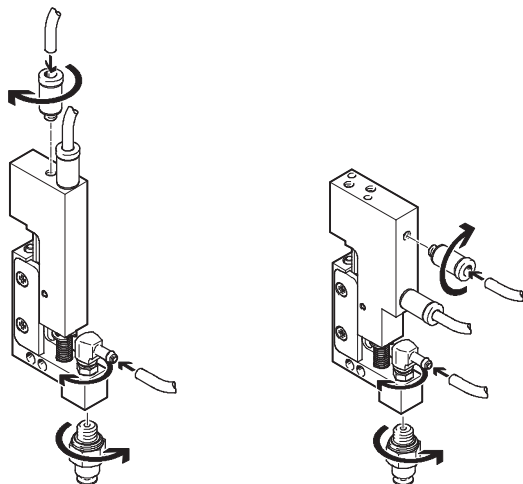

Mini slides DGSC

Type codes and peripherals overview

Type codes

		DGSC	-	6	-	10	-	P	-	P
Type										
Double-acting										
DGSC	Mini slide									
Size										
Stroke [mm]										
Cushioning										
P	Elastic cushioning without metal end stop, both ends									
Supply ports										
L	In the direction of movement of the slide									
P	On the side of the housing									

Overview of peripherals

Supply ports in the direction of movement of the slide

Supply ports on the side of the housing

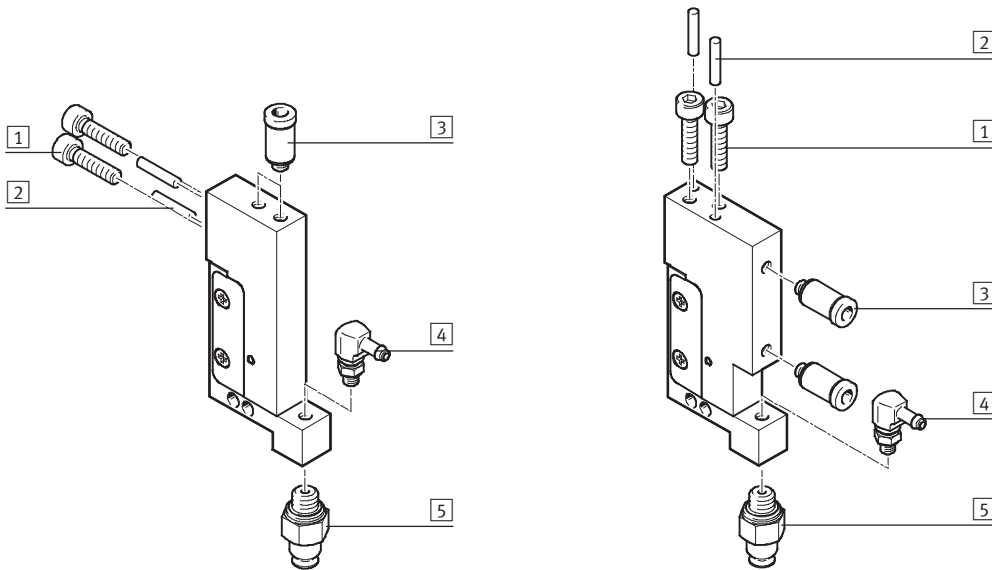



Accessories		Brief description	→ Page/Internet
1	Screw	For mounting the mini slide	-
2	Centring pin Ø 2, to EN ISO 2338	For centring the mini slide during assembly	-
3	Push-in fitting QSM	For supplying compressed air to the mini slide	8
4	Push-in L-fitting QSML	For connecting vacuum or compressed air to the slide	8
5	Suction cup VAS	-	8

Mini slides DGSC

Technical data

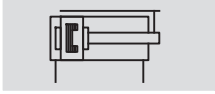
Function



 Size
6

 Stroke length
10 mm



General technical data		
Size		6
Stroke	[mm]	10
Pneumatic connection		M3
Design		Scotch yoke system
Guide		Ball bearing cage guide
Type of mounting		Via female thread and dowel pin
Cushioning		Elastic cushioning rings/pads at both ends
Position sensing		None
Mounting position		Any
Max. effective load ¹⁾	[g]	30
Max. operating frequency	[Hz]	< 4
Contact resistance	[Ω]	< 5
Repetition accuracy	[mm]	±0.1

1) For unthrottled operation.

Operating and environmental conditions		
Operating medium		Dried compressed air, lubricated or unlubricated
Operating pressure	[bar]	1 ... 6
Ambient temperature	[°C]	10 ... 50
Corrosion resistance class CRC ²⁾		2

2) Corrosion resistance class 2 according to Festo standard 940 070
Components subject to moderate corrosion stress. Externally visible parts with primarily decorative surface requirements which are in direct contact with a normal industrial environment or media such as coolants or lubricating agents.

Weight [g]		
Type	DGSC-6-10-P-L	DGSC-6-10-P-P
Product weight	42	52
Moving load	17	17

Forces [N]	
Theoretical force at 6 bar, advance	17
Theoretical force at 6 bar, retract	12.7
Measured force at 6 bar, advance	15.5

Travel times [ms] at 6 bar	
Advancing	19
Retracting	16.5

Mini slides DGSC

Technical data

Materials

Sectional view

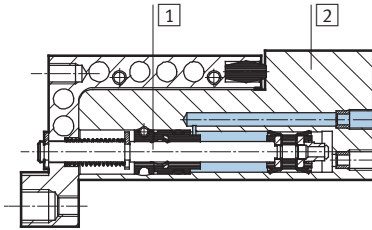

Mini slide		
1	Piston rod	High-alloy stainless steel
2	Housing	High-alloy stainless steel
-	Seals	Nitrile rubber
Note on materials		Free of copper and PTFE
		RoHS-compliant

Static characteristic load values

The indicated forces and torques refer to the guide. These values must not be exceeded during dynamic operation. Special attention must be paid to the cushioning phase.

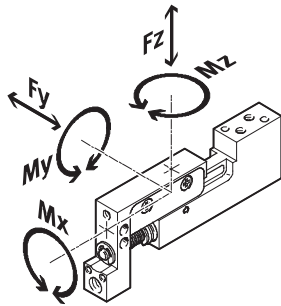

If the drive is simultaneously subjected to several of the indicated forces and torques, the following equation must be satisfied in addition to the indicated maximum loads:

$$\frac{F_y}{F_{y_{max}}} + \frac{F_z}{F_{z_{max}}} + \frac{M_x}{M_{x_{max}}} + \frac{M_y}{M_{y_{max}}} + \frac{M_z}{M_{z_{max}}} \leq 1$$

Permissible forces and torques

$F_{y_{max}}$	[N]	20
$F_{z_{max}}$	[N]	20
$M_{x_{max}}$	[Nm]	0.3
$M_{y_{max}}$	[Nm]	0.4
$M_{z_{max}}$	[Nm]	0.4

Mini slides DGSC

Technical data

Slide displacement at max. stroke

Longitudinal load

Transverse load

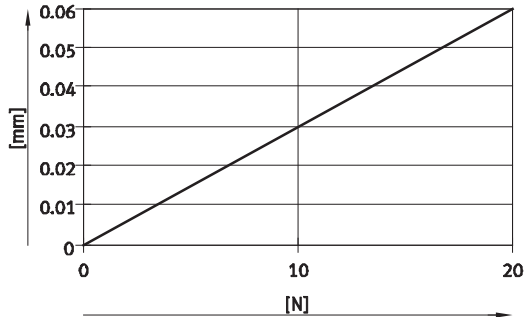
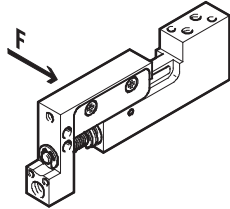
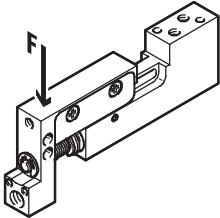

DGSC-6-10-P-...

Stroke compensation

The integrated spring enables stroke compensation of 2.5 mm if there is a risk of collision in the advanced state. Only low spring forces then act on the yoke.

This protects the mechanism from overload.

Stroke:
L1 = 10 mm

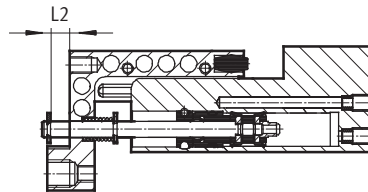
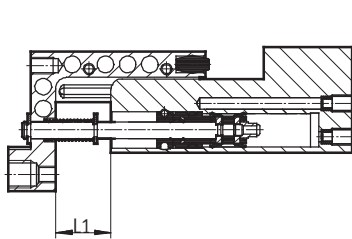

Stroke compensation (L2)	[mm]	0	2.5
Spring force	[N]	2.0	2.4

Parallelism/perpendicularity/linearity [mm]

Parallelism/perpendicularity:

Accuracy of alignment between the housing mounting surface and the mounting interface on the yoke.

DGSC-6-10-P-L

DGSC-6-10-P-P

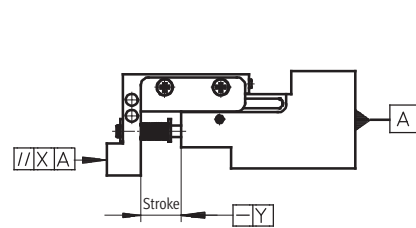
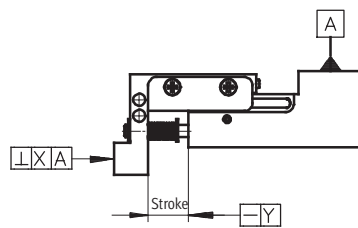

Linearity:

Maximum distance between individual points on the slide and the housing mounting surface with the drive in retracted and advanced state.

Type		DGSC-6-10-P-L	DGSC-6-10-P-P
Parallelism	[mm]	-	< 0.03
Perpendicularity	[mm]	< 0.03	-
Linearity	[mm]	< 0.01	

Mini slides DGSC

Technical data

Dimensions

Download CAD data → www.festo.com

DGSC-6-10-P-L

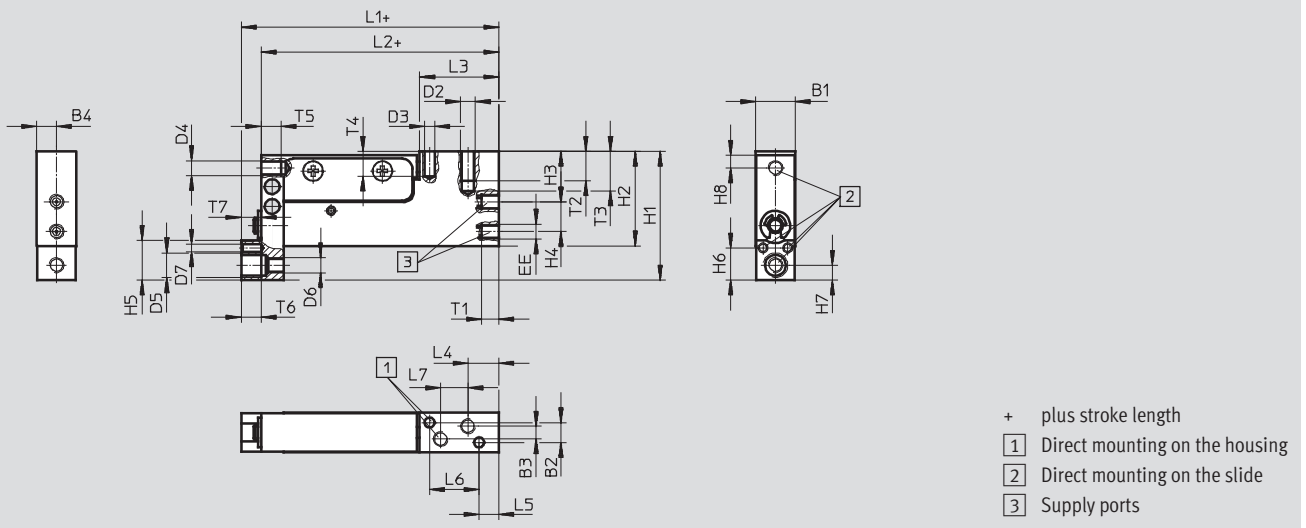

DGSC-6-10-P-P

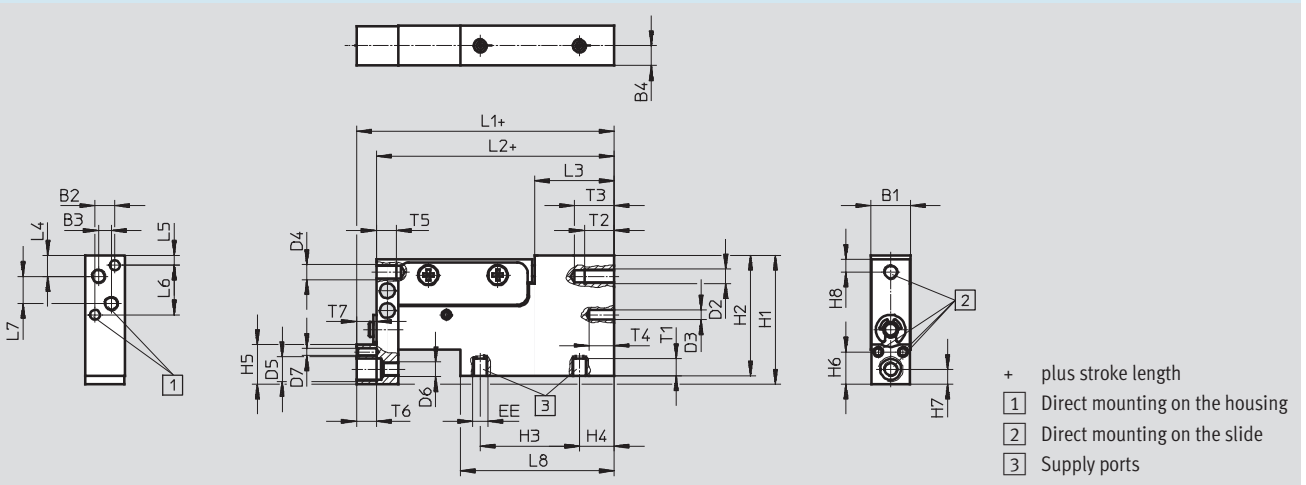

Type	B1	B2	B3	B4	D2	D3	D4	D5	D6	D7	EE
	-0.05/-0.15	±0.02	±0.1			∅ H8				∅ H8	
DGSC-6-10-P-L	8	4	2.6	4	M3	2	M3	M5	M3	1.5	M3
DGSC-6-10-P-P	8	4	2.6	4	M3	2	M3	M5	M3	1.5	M3

Type	H1	H2	H3	H4	H5	H6	H7	H8	L1	L2	L3
						±0.02					
DGSC-6-10-P-L	26	19.1	10.2	6	8	6.5	3	2.6	52	48	16
DGSC-6-10-P-P	26	24.3	20	7	8	6.5	3	2.6	52	48	16

Type	L4	L5	L6	L7	L8	T1	T2	T3	T4	T5	T6	T7
			±0.02	±0.1		max.	min.	+1	+1	min.	min.	+1
DGSC-6-10-P-L	6.25	4	10	5.5	-	3.5	6	8	5	4	4	4
DGSC-6-10-P-P	4.25	2	10	5.5	31	3.5	6	8	5	4	4	4



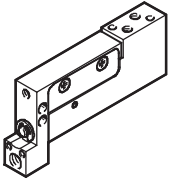

Mini slides DGSC

Technical data

Ordering data					
	Type	Brief description	Part No.	Type	
	DGSC-6-10-P-L	Supply ports in the direction of movement of the slide	569793	DGSC-6-10-P-L	
	DGSC-6-10-P-P	Supply ports on the side of the housing	569792	DGSC-6-10-P-P	

Accessories

Ordering data – Fitting

Type	Connection		Weight [g]	Part No.	Type	PU ¹⁾
	Thread	For tubing Ø [mm]				
For supplying compressed air to the mini slide						
Push-in fitting QSM Technical data → Internet: qsm						
	M3	3 (outside)	3	132914	QSM-M3-3-I-R-100	100
Barbed fitting CN Technical data → Internet: cn						
	M3	2 (inside)	3	15871	CN-M3-PK-2	10
	M3	3 (inside)	3	15872	CN-M3-PK-3	
Barbed L-fitting LCN Technical data → Internet: lcn						
	M3	2 (inside)	2	30491	LCN-M3-PK-2-B	10
	M3	3 (inside)	2	30982	LCN-M3-PK-3	
For connecting vacuum or compressed air to the slide						
Push-in L-fitting QSML Technical data → Internet: qsml						
	M3	3 (outside)	2	153330	QSML-M3-3	10
	M3	3 (outside)	2	132106	QSML-B-M3-3-20	20
	M3	3 (outside)	2	130768	QSML-M3-3-100	100
Barbed L-fitting LCN Technical data → Internet: lcn						
	M3	2 (inside)	2	30491	LCN-M3-PK-2-B	10
	M3	3 (inside)	2	30982	LCN-M3-PK-3	

Ordering data – One-way flow control valve

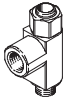
Type	Connection		Function	Weight [g]	Part No.	Type	PU ¹⁾
	Male thread						
For supplying compressed air to the mini slide Technical data → Internet: grl							
	M3		Exhaust air flow control	3	175038	GRLA-M3	1
	M3		Supply air flow control	3	175040	GRLZ-M3	

Ordering data – Suction cup

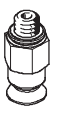
Type	Connection		Material	Weight [g]	Part No.	Type	PU ¹⁾
	Thread	For suction cup Ø [mm]					
	M5	8	Nitrile rubber	4	34588	VAS-8-M5-NBR	1
	M5	8	Polyurethane	4	36135	VAS-8-M5-PUR	
	M5	8	Silicone	2	160988	VAS-8-M5-SI	

1) Packaging unit