







- 气管插入简单
- 容易卸管
- 可靠的接头
- 派生型品种丰富

快插接头 QS

主要特性一览

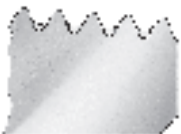

应用	简单的“即插即用”	连接可靠	自密封
 <p>不费力气即可正确选择管接头，快插系列提供各种气管的连接。管接头可方便地插入，快插管接头包括 1000 多种标准和功能管接头。</p>	 <p>插入式接头内部的不锈钢片将气管牢固卡紧，而不损坏其表面。机械振动和压力波动被安全地吸收。 压下端头，即可拔出气管。</p>	 <p>丁腈橡胶密封环保证了标准外径气管和快插管接头间的良好密封。 标准气管可用于压缩空气和真空。</p>	 <p>Festo插入式螺纹接头为镀镍黄铜元件，具有良好的耐腐蚀性。其ISO R 螺纹上带有自密封的聚四氟乙烯涂层。这种接头在不加其它密封件的情况下可重复使用五次，具有良好的密封性能。</p>

360° 旋转	360° 旋转，带球轴承
 <p>校准工作在装配时完成。气管的移动在使用过程中得到补偿。</p>	 <p>使用过程中允许旋转运动高达 500 rpm。</p>

接头和螺纹的匹配

公制螺纹

- 圆柱形公制螺纹和 G 螺纹相类似
- 通过卡入式 O 形圈确保密封

G 螺纹
符合 DIN ISO 228-1 标准

- 螺纹较短
- 固定安装深度
- 密封圈可更换
- 密封在顶部
- 采用可更换密封圈，因此可重复使用

R 螺纹
符合 DIN 2999-1 和 ISO 7/1 标准

- 自密封螺纹
- 密封在螺纹上
- 不需要密封平面
- 无需密封平面，安装尺寸更小
- 可重复利用达五次

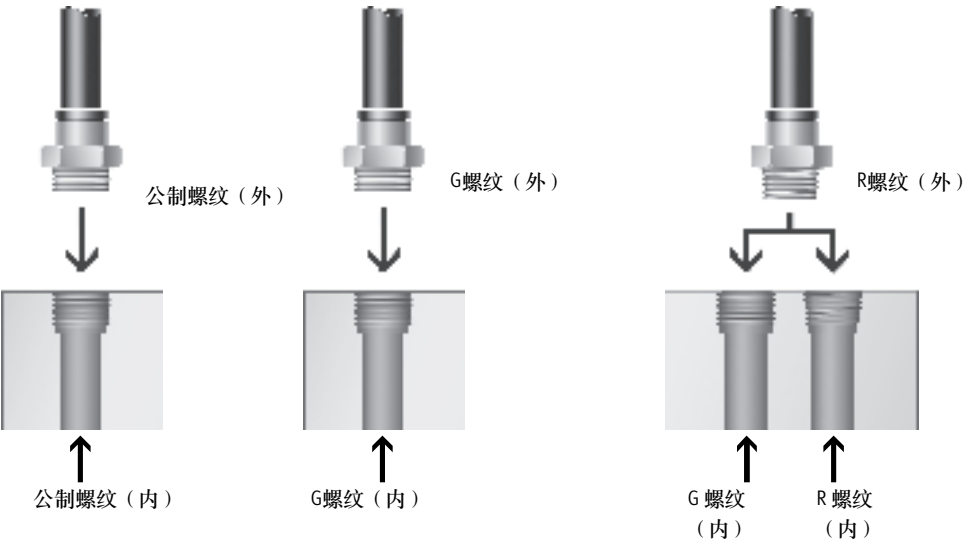

公制螺纹 (外) G 螺纹 (外) R 螺纹 (外)

公制螺纹 (内) G 螺纹 (内) G 螺纹 (内) R 螺纹 (内)

快插接头 QS

技术参数

FESTO

快插接头 QSM

小型



小型快插接头适用于狭小空间安装。
小型系列包括气管外径 3, 4 和 6 mm, 连接螺纹 M3, M5, M7, R $\frac{1}{8}$ 和 G $\frac{1}{8}$ 。

快插接头 QS

标准型



种类多样的快插接头, 适用于大多数标准应用场合。
气管外径为 4, 6, 8, 10, 12 和 16 mm, 其连接螺纹为 R $\frac{1}{8}$... $\frac{1}{2}$ 和 G $\frac{1}{8}$ 到 G $\frac{1}{2}$ 。

快插接头 QS-F

金属型



坚固的金属快插接头, 用于食品工业, 应用场合温度可高达 150°C。
耐腐蚀能力强。

快插接头 CRQS

不锈钢型



不锈钢快插接头。
耐腐蚀和化学物质能力极强。
适用于食品和包装工业。

快插接头 QS-V0

阻燃型



适用于所有易燃场合, 如: 自动化工业中的焊接系统。
适用的气管 PAN-V0, 符合 UL 94 V0 标准。
→ 3 / 5.2-1

材料

剖面图

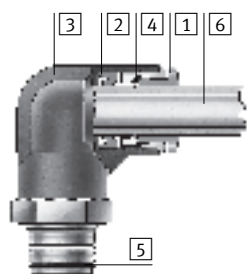

	小型 QSM	标准型 QS	金属型 QS-F	不锈钢型 CRQS	阻燃型 QS-V0
1 卸管压环	聚碳酸酯		镀镍、镀铬黄铜	不锈钢	聚乙烯对苯二甲酸酯 (阻燃)
2 唇形密封圈	丁腈橡胶		碳氟橡胶	碳氟橡胶	丁腈橡胶
3 外壳	钢 聚乙烯对苯二甲酸酯 镀镍黄铜 阳极氧化铝		镀镍、镀铬黄铜	不锈钢	聚乙烯对苯二甲酸酯 (阻燃)
4 气管卡片	黄铜 不锈钢		黄铜 不锈钢	不锈钢	黄铜 不锈钢
5 螺纹接头	镀镍黄铜, 聚四氟乙烯密封组件		镀镍、镀铬黄铜	不锈钢	镀镍黄铜, 聚四氟乙烯密封组件
6 标准外径塑料气管	PAN PUN PUN-H PUN-E		PAN PFAN PUN PUN-H PUN-V0 PLN	PFAN PUN-H PLN PUN-V0	PAN-V0

快插接头 QS

技术参数

FESTO

建议使用的紧固力矩/拧入深度



使用快插接头时，确保内六角扳手不能插入太深，以免损坏接头后面的元件。

注意
接头螺纹拧入过深会使快插接头出现故障。必须遵守拧入深度和推荐紧固力矩。如果紧固力矩超过推荐值 50% 会导致器件损坏。

连接螺纹	紧固力矩 [Nm]	拧入深度 (约值) [mm]
螺纹 M		
M3	0.7	3
M5	1.5	2
螺纹 R		
R $\frac{1}{8}$	7	4
R $\frac{1}{4}$	12	6
R $\frac{3}{8}$	22	6.5
R $\frac{1}{2}$	28	8
螺纹 G		
G $\frac{1}{8}$	10	4
G $\frac{1}{4}$	15	6
G $\frac{3}{8}$	25	6.5
G $\frac{1}{2}$	40	8

气管插入深度



气管外径 [mm]	3	4	6	8	10	12	16
小型 QSM	11	12	16	-	-	-	-
标准型 QS	-	15	17	18	21	23	25

工作和环境条件

	小型 QSM	标准型 QS	金属型 QS-F	不锈钢型 CRQS	阻燃型 QS-V0
工作压力 [bar]	-0.95 ... +10		-0.95 ... +10	-0.95 ... +10	-0.95 ... +10
工作温度 [°C]	0 ... 60		0 ... 150	0 ... 150	0 ... 60
耐腐蚀等级 CRC ¹⁾	1		3	4	2

1) 耐腐蚀等级 1，符合 Festo 940 070 标准
 元件只需具备低度耐腐蚀能力。运输和贮存防护。这些元件无表面基本涂层要求，譬如：内部元件或位于盖子下面的元件。
 耐腐蚀等级 2，符合 Festo 940 070 标准
 元件必须具备一定的耐腐蚀能力。外部可视元件具备基本的涂层表面，可直接与工业环境或与冷却液、润滑剂等介质接触。
 耐腐蚀等级 3，符合 Festo 940 070 标准
 元件必须具备一定的耐腐蚀能力。由于外部可视元件直接与工业环境或与溶剂、清洁剂等介质接触，因此对元件表面有较强的耐腐蚀性要求。
 耐腐蚀等级 4，符合 Festo 940 070 标准
 元件需具备很强的耐腐蚀能力。因为元件用于腐蚀性介质中，例如在食品或在化工行业中。如果需要的话，在应用前应该对元件与介质一起进行特别的测试。

快插接头 QS

技术参数

FESTO

快插接头/气管可能的组合							
螺纹	气管外径 [mm]						
	3	4	6	8	10	12	16
小型 QSM							
M3	■		-	-	-	-	-
M5		■		-	-	-	-
M6	-	■	-	-	-	-	-
M7	-		■	-	-	-	-
M8	-	-	■	-	-	-	-
R1/8	-		■	-	-	-	-
G1/8	-		■	-	-	-	-
标准型 QS							
M5	-	■		-	-	-	-
R1/8	-		■				
R1/4	-			■			
R3/8	-	-			■		
R1/2	-	-	-	-		■	
G1/8	-		■				
G1/4	-	-		■			
G3/8	-	-	-		■		
G1/2	-	-	-	-		■	
阻燃型 QS-V0							
R1/8	-	-	■				
R1/4	-	-		■			
R3/8	-	-	-		■		
R1/2	-	-	-	-		■	
G1/8	-	-	■				
G1/4	-	-		■			
G3/8	-	-	-		■		
G1/2	-	-	-	-		■	
金属型 QS-F							
M5	-	■					
M7	-		■				
G1/8	-		■				
G1/4	-	-		■			
G3/8	-	-	-		■		
G1/2	-	-	-	-		■	
不锈钢型 CRQS							
M5	-	■					
R1/8	-	-	■				
R1/4	-	-	-	■			
R3/8	-	-	-	-	■		
R1/2	-	-	-	-	-	■	

- 螺纹/气管外径可能的组合
- 螺纹/气管外径最佳的组合 (和气流相关)











快插接头 QSM, 小型

产品范围一览

FESTO

硬管、气管和接头
快插接头













5.4

结构特点	型式	型号	接口 D1				插入套管直径 ∅	接口 D2		→ 页码
			M 螺纹	R 螺纹	G 螺纹	气管外径		气管外径		
直通形结构	快插接头 - 外螺纹, 带外六角									
		QSM	M3	-	-	-	-	3, 4	3 / 5.4-19	
			M5					3, 4, 6		
			-	R1/8	G1/8	-	-	4, 6		
	快插接头 - 外螺纹, 带内六角									
		QSM-...I	M3	-	-	-	-	3, 4	3 / 5.4-20	
			M5					3, 4, 6		
			M7	R1/8	G1/8			4, 6		
	快插接头 - 内螺纹, 带外六角									
		QSMF	M3	-	-	-	-	3, 4	3 / 5.4-21	
			M5					3, 4		
	快插接头 - 外螺纹, 带内六角									
		QSMF	M6x0.75	-	-	-	-	4	3 / 5.4-21	
			M8x0.75					6		
	快插接头									
	QSM	-	-	-	3	-	3	3 / 5.4-22		
		4				4				
		6				6				
	QSM 变径	-	-	-	4	-	3	3 / 5.4-22		
		6				4				
穿板式快插接头										
	QSMF	-	-	-	3	-	-	3 / 5.4-22		
		4				4				
		6				6				
插入式堵头										
	QSMC	-	-	-	3	-	-	3 / 5.4-23		
快插接头, 带轴套										
	QSM-...H	-	-	-	-	4	3	3 / 5.4-23		
		6					4			
空位堵头										
	QSMC-...H	-	-	-	-	3	-	3 / 5.4-23		

快插接头 QSM, 小型

产品范围一览

FESTO

结构特点	型式	型号	接口 D1					接口 D2		→ 页码
			M 螺纹	R 螺纹	G 螺纹	气管外径	插入套管直径 ∅	气管外径		
L形	L形快插接头, 360° 旋转 - 外螺纹, 带外六角									
		QSML	M3	-	-	-	-	3, 4	3 / 5.4-24	
			M5					3, 4, 6		
			M7	R1/8	G1/8			4, 6		
	L形快插接头, 360° 旋转 - 外螺纹, 带外六角									
		QSMLL	M3	-	-	-	-	3, 4	3 / 5.4-25	
			M5					3, 4, 6		
			M7	R1/8	G1/8			4, 6		
	L形快插接头									
		QSML	-	-	-	3	-	-	3 / 5.4-26	
					4					
					6					
L形快插接头, 带套管										
	QSML-..H	-	-	-	-	3	3	3 / 5.4-26		
							4		4	
							6		6	
	QSML-..H 变径	-	-	-	-	4	3	3 / 5.4-26		
							6		4	
T形	T形快插接头, 360° 旋转 - 外螺纹, 带外六角									
		QSMT	M3	-	-	-	-	3, 4	3 / 5.4-27	
			M5					3, 4, 6		
			-	R1/8	G1/8			4, 6		
		QSMTL	M3	-	-	-	-	3, 4	3 / 5.4-28	
			M5					3, 4, 6		
			-	R1/8	G1/8			4, 6		
	T形快插接头									
		QSMT	-	-	-	3	-	3	3 / 5.4-29	
						4		4		
					6		6			
	QSMT 变径	-	-	-	3	-	4	3 / 5.4-29		
					4		6			
X形	X形快插接头									
		QSMX	-	-	-	3	-	-	3 / 5.4-30	
						4				
					6					
Y形	Y形快插接头									
		QSMY	-	-	-	3	-	3	3 / 5.4-30	
						4		4		
						6		6		
		QSMY 变径	-	-	-	4	-	3	3 / 5.4-30	
					6		4			









快插接头 QS, 标准型

产品范围一览

FESTO

硬管、气管和接头
快插接头

5.4









结构特点	型式	型号	接口 D1				接口 D2		→ 页码	
			M 螺纹	R 螺纹	G 螺纹	气管外径	插入套管直径∅	气管外径		插入套管直径∅
直通结构	快插接头 - 外螺纹, 带外六角									
		QS	-	R1/8	G1/8	-	-	4, 6, 8, 10 ¹⁾	-	3 / 5.4-31
				R1/4	G1/4			4 ¹⁾ , 6, 8, 10, 12		
				R3/8	G3/8			6 ¹⁾ , 8, 10, 12, 16		
				R1/2	G1/2			10 ¹⁾ , 12, 16		
	快插接头 - 外螺纹, 带内六角									
		QS-...I	-	R1/8	G1/8	-	-	4, 6, 8, 10 ¹⁾	-	3 / 5.4-33
				R1/4	G1/4			6, 8, 10, 12 ¹⁾		
				R3/8	G3/8			8, 10, 12		
				R1/2	G1/2			10 ¹⁾ , 12		
	快插接头 - 内螺纹, 带外六角									
		QSF	-	-	G1/8	-	-	4, 6, 8	-	3 / 5.4-34
					G1/4			4, 6, 8, 10, 12		
					G3/8			6, 8, 10, 12		
				G1/2			12, 16			
快插接头										
	QS	-	-	-	4	-	4	-	3 / 5.4-35	
					6		6			
					8		8			
					10		10			
					12		12			
					16		16			
	QS 变径	-	-	-	6	-	4	-	3 / 5.4-35	
					8		4, 6			
					10		6, 8			
					12		8, 10			
穿板式快插接头										
	QSS	-	-	-	4	-	-	-	3 / 5.4-36	
					6					
					8					
					10					
					12					
穿板式快插接头, 带固定凸缘										
	QSS-...F	-	-	-	8	-	-	-	3 / 5.4-36	
					10					
					12					
穿板式快插接头, 带内螺纹										
	QSSF	-	-	G1/8	-	-	4, 6, 8	-	3 / 5.4-37	
				G1/4			4, 6, 8, 10			
				G3/8			6, 8, 10, 12			
				G1/2			12, 16			

1) 仅允许与 R 螺纹一起使用

快插接头 QS, 标准型

产品范围一览

FESTO

结构特点	型式	型号	接口 D1				接口 D2			→ 页码
			M 螺纹	R 螺纹	G 螺纹	气管外径	插入套管直径 \varnothing	气管外径	插入套管直径 \varnothing	
直通结构	插入式堵头									
		QSC	-	-	-	4	-	-	-	3 / 5.4-38
						6				
						8				
						10				
						12				
	快插接头, 带套管									
		QS-...H	-	-	-	-	6	4	-	3 / 5.4-38
							8	4, 6		
							10	6, 8		
						12	8, 10			
插入式堵头										
	QSH	-	-	-	-	4	-	-	3 / 5.4-39	
						6				
						8				
						10				
						12				
	QSH 变径	-	-	-	-	6	-	4	3 / 5.4-39	
						8		6		
						10		8		
						12		10		
						16		12		
堵头										
	QSC-...H	-	-	-	-	4	-	-	3 / 5.4-40	
						6				
						8				
						10				
						12				
L形	快插接头, 360° 旋转 - 外螺纹, 带外六角									
		QSL	-	R $\frac{1}{8}$	G $\frac{1}{8}$	-	-	4, 6, 8, 10 ¹⁾	-	3 / 5.4-41
				R $\frac{1}{4}$	G $\frac{1}{4}$			4 ¹⁾ , 6, 8, 10, 12		
				R $\frac{3}{8}$	G $\frac{3}{8}$			6 ¹⁾ , 8, 10, 12, 16		
				R $\frac{1}{2}$	G $\frac{1}{2}$			10 ¹⁾ , 12, 16		
	加长快插接头, 360° 旋转 - 外螺纹, 带外六角									
		QSLL	-	R $\frac{1}{8}$	G $\frac{1}{8}$	-	-	4, 6, 8	-	3 / 5.4-43
				R $\frac{1}{4}$	G $\frac{1}{4}$			4 ¹⁾ , 6, 8, 10		
				R $\frac{3}{8}$	G $\frac{3}{8}$			6 ¹⁾ , 8, 10, 12		
				R $\frac{1}{2}$	G $\frac{1}{2}$			10 ¹⁾ , 12, 16 ²⁾		
L形快插接头 - 内螺纹, 带外六角										
	QSLF	-	-	G $\frac{1}{8}$	-	-	4, 6, 8	-	3 / 5.4-44	
				G $\frac{1}{4}$			6, 8, 10			
				G $\frac{3}{8}$			8, 10			

1) 仅允许与 R 螺纹一起使用
2) 仅允许与 G 螺纹一起使用

快插接头 QS, 标准型

产品范围一览

FESTO

硬管、气管和接头
快插接头







5.4

结构特点	型式	型号	接口 D1				接口 D2		→ 页码	
			M 螺纹	R 螺纹	G 螺纹	气管外径	插入套管直径 Ø	气管外径		插入套管直径 Ø
	L形快插接头, 360° 旋转 - 外螺纹, 带内六角									
		QSLV-...1	-	R 1/8	G 1/8	-	-	6, 8	-	3 / 5.4-45
				R 1/4	G 1/4			6, 8, 10		
				R 3/8	G 3/8			8, 10, 12		
				R 1/2	G 1/2			12		
	L形快插接头, 360° 旋转 - 外螺纹, 带外六角									
		QSLV	M5	-	-	-	-	6	-	3 / 5.4-46
			-	R 1/8	G 1/8	-	-	4, 6, 8	-	
				R 1/4	G 1/4	-	-	6, 8, 10	-	
				R 3/8	G 3/8	-	-	8, 10, 12	-	
复合型管接头, 360° 旋转 - 2 路输出										
	QSLV2	-	R 1/8	G 1/8	-	-	4, 6, 8	-	3 / 5.8-9	
			R 1/4	G 1/4			6, 8, 10			
			R 3/8	G 3/8			8, 10, 12			
			R 1/2	G 1/2			12			
复合型管接头, 360° 旋转 - 3 路输出										
	QSLV3	-	R 1/8	G 1/8	-	-	4, 6, 8	-	3 / 5.8-10	
			R 1/4	G 1/4			6, 8, 10			
			R 3/8	G 3/8			8, 10, 12			
			R 1/2	G 1/2			12			
复合型管接头, 360° 旋转 - 4 路输出										
	QSLV4	-	R 1/8	G 1/8	-	-	4, 6, 8	-	3 / 5.8-11	
			R 1/4	G 1/4			6, 8, 10			
			R 3/8	G 3/8			8, 10, 12			
			R 1/2	G 1/2			12			
复合型管接头, 360° 旋转 - 6 路输出										
	QSLV6	-	R 1/8	G 1/8	-	-	4, 6, 8	-	3 / 5.8-12	
			R 1/4	G 1/4			6, 8, 10			
			R 3/8	G 3/8			8, 10, 12			
			R 1/2	G 1/2			12			
复合型管接头, 360° 旋转 - 4 路输出										
	QSQ	-	R 1/8	G 1/8	-	-	4, 6	-	3 / 5.8-13	
			R 1/4	G 1/4			4, 6			
	QSQ 变径	-	-	-	6 8	-	4 6	-	3 / 5.8-13	

- 1) 仅允许与 R 螺纹一起使用
- 2) 仅允许与 G 螺纹一起使用

快插接头 QS, 标准型

产品范围一览

结构特点	型式	型号	接口 D1				接口 D2		→ 页码	
			M 螺纹	R 螺纹	G 螺纹	气管外径	插入套管直径 \varnothing	气管外径		插入套管直径 \varnothing
L形	L形快插接头									
		QSL	-	-	-	4	-	-	-	3 / 5.4-48
						6				
						8				
						10				
						12				
						16				
	L形快插接头, 带套管									
		QSL...H	-	-	-	-	4	-	4	3 / 5.4-49
							6		6	
							8		8	
							10		10	
						12		12		
	QSL...H 变径	-	-	-	-	4	-	6	3 / 5.4-49	
						6		8		
						8		10		
						10		12		
	QSL...HL 加长插入式 套管	-	-	-	-	4	-	4	3 / 5.4-49	
						6		6		
						8		8		
						10		10		
						12		12		
T形	T形快插接头, 360° 旋转 - 外螺纹, 带外六角									
		QST	-	R1/8	G1/8	-	-	4, 6, 8, 10 ¹⁾	-	3 / 5.4-50
				R1/4	G1/4			4 ¹⁾ , 6, 8, 10, 12 ¹⁾		
				R3/8	G3/8			6 ¹⁾ , 8, 10, 12, 16		
				R1/2	G1/2			10, ¹⁾ 12, 16		
	T形快插接头									
		QST	-	-	-	4	-	4	-	3 / 5.4-52
						6		6		
						8		8		
						10		10		
						12		12		
						16		16		
	QST 变径	-	-	-	6	-	4	-	3 / 5.4-52	
					8		4, 6			
					10		6, 8			
					12		8, 10			
					16		12			

1) 仅允许与 R 螺纹一起使用



快插接头 QS, 标准型





产品范围一览

FESTO

硬管、气管和接头
快插接头

5.4









结构特点	型式	型号	接口 D1				接口 D2		接口 D3	→ 页码
			R 螺纹	G 螺纹	气管外径	插入套管直径 \varnothing	气管外径	插入套管直径 \varnothing	气管外径	
T形	复合型管接头, 360° 旋转 - 3 路输出									
		QST3	R1/8	G1/8	-	-	6	-	4	3 / 5.8-14
			R1/4	G1/4			8		6	
			R3/8	G3/8			10		8	
		QST3 变径	-	-	6	-	6	-	4	3 / 5.8-14
			-	-	8	-	8	-	6	
-			-	10	-	10	-	8		

结构特点	型式	型号	接口 D1				接口 D2		→ 页码	
			M 螺纹	R 螺纹	G 螺纹	气管外径	插入套管直径 \varnothing	气管外径		插入套管直径 \varnothing
T形	T形快插接头, 360° 旋转 - 外和内螺纹, 带外六角									
		QSTF	-	R1/8	G1/8	-	-	4, 6, 8	-	3 / 5.4-53
			-	R1/4	G1/4			6, 8, 10		
			-	R3/8	G3/8			8, 10, 12		
			-	R1/2	G1/2			12		
	T形快插接头, 360° 旋转 - 外螺纹, 带外六角									
		QSTL	-	R1/8	G1/8	-	-	4, 6, 8	-	3 / 5.4-54
			-	R1/4	G1/4			6, 8, 10		
			-	R3/8	G3/8			8, 10, 12		
			-	R1/2	G1/2			12, 16		
直角结构	快插接头-外螺纹, 带外六角									
		QSW	-	R1/8	-	-	-	4, 6, 8	-	3 / 5.4-56
			-	R1/4				6, 8, 10		
			-	R3/8				10, 12		
			-	R1/2				12, 16		
	快插接头, 带套管									
		QSW-HL	-	-	-	4	-	-	4	3 / 5.4-56
			-	-	-	6	-	-	6	
			-	-	-	8	-	-	8	
			-	-	-	10	-	-	10	
-			-	-	12	-	-	12		
X形	X形快插接头									
		QSX	-	-	-	8	-	-	-	3 / 5.4-57
			-	-	-	10	-	-	-	
-			-	-	12	-	-	-		

快插接头 QS, 标准型

产品范围一览







FESTO

结构特点	型式	型号	接口 D1				接口 D2		→ 页码	
			M 螺纹	R 螺纹	G 螺纹	气管外径	插入套管直径 ∅	气管外径		插入套管直径 ∅
Y形	Y形快插接头, 360° 旋转 - 外螺纹, 带外六角									
		QSY	M5	-	-	-	-	4, 6	-	3 / 5.4-58
				R1/8	G1/8			4, 6, 8		
				R1/4	G1/4			4 ¹⁾ , 6, 8, 10		
				R3/8	G3/8			8, 10, 12		
				R1/2	G1/2			12		
	Y形快插接头									
		QSY	-	-	-	4	-	4	-	3 / 5.4-60
						6		6		
						8		8		
						10		10		
						12		12		
		QSY 变径	-	-	-	6	-	4	-	3 / 5.4-60
						8		4, 6		
					10		6, 8			
					12		8, 10			
					16		12			
Y形快插接头, 带套管										
	QSY-...H	-	-	-	-	4	4	-	3 / 5.4-61	
						6	6			
						8	8			
						10	10			
						12	12			
	QSY-...H 变径	-	-	-	-	6	4	-	3 / 5.4-61	
						8	6			
						10	8			
						12	10			
Y形快插接头, 360° 旋转 - 外螺纹, 带外六角										
	QSYL	-	R1/8	G1/8	-	-	4, 6, 8	-	3 / 5.4-62	
			R1/4	G1/4			6, 8, 10			
			R3/8	G3/8			8, 10, 12			
			R1/2	G1/2			12			
Y形快插接头, 360° 旋转 - 外螺纹, 带外六角										
	QSYLV	-	R1/8	G1/8	-	-	6	-	3 / 5.4-63	
			R1/4	G1/4			8			
			R3/8	G3/8			10			
			R1/2	G1/2			12			
Y形快插接头, 360° 旋转 - 外和内螺纹, 带外六角										
	QSYTF	-	R1/8	G1/8	-	-	6	-	3 / 5.4-64	
			R1/4	G1/4			8			
			R3/8	G3/8			10			
			R1/2	G1/2			12			
卸管工具										
	QS0	-							3 / 5.4-85	

- 1) 仅允许与 R 螺纹一起使用
- 2) 仅允许与 G 螺纹一起使用





快插接头 QS-F, 金属型

产品范围一览

结构特点	型式	型号	接口 D1					接口 D2		→ 页码	
			M 螺纹	R 螺纹	G 螺纹	气管外径	插入套管直径∅	气管外径	插入套管直径∅		
直通结构	快插接头 - 外螺纹, 带外六角										
		QS-F	M5	-	-	4, 6	-	-	-	3 / 5.4-65	
			M7		-	4, 6					
			-		G1/8	4, 6, 8					
			-		G1/4	6, 8, 10, 12					
			-		G3/8	8, 10, 12					
			-		G1/2	10, 12					
	快插接头 - 外螺纹, 带内六角										
		QS-F...-I	M5	-	-	4	-	-	-	3 / 5.4-66	
			M7		-	4, 6					
			-		G1/8	4, 6, 8					
			-		G1/4	6, 8, 10, 12					
			-		G3/8	8, 10, 12					
	快插接头 - 内螺纹, 带外六角										
		QSF-F	-	-	-	G1/8	4, 6, 8	-	-	-	3 / 5.4-66
			-		G1/4	6, 8					
	穿板式快插接头 - 内螺纹, 带外六角										
		QSSF-F	-	-	-	G1/8	4, 6, 8	-	-	-	3 / 5.4-67
-			G1/4		6, 8						
快插接头, 带套管											
	QS-F...H	M5	-	-	4, 6	-	-	-	3 / 5.4-68		
		M7		-	4, 6						
		-		G1/8	4, 6, 8						
		-		G1/4	6, 8, 10, 12						
		-		G3/8	8, 10, 12						
		-		G1/2	10, 12						
快插接头											
	QS-F	-	-	-	4	-	-	-	3 / 5.4-69		
		-		6							
		-		8							
		-		10							
		-		12							
穿板式快插接头											
	QSSF-F	-	-	-	4	-	-	-	3 / 5.4-72		
		-		6							
		-		8							
		-		10							
		-		12							

快插接头 QS-F, 金属型

产品范围一览

结构特点	型式	型号	接口 D1				接口 D2		→ 页码			
			M 螺纹	R 螺纹	G 螺纹	气管外径	插入套管直径∅	气管外径		插入套管直径∅		
直通结构	快插接头, 带套管											
		QS-F...H	-	-	-	6	-	-	4	3 / 5.4-69		
						8			4			
						8			6			
						10			4			
						10			6			
						10			8			
						12			6			
						12			8			
						12			10			
插入式套管												
	QSH-F	-	-	-	4	-	-	4	3 / 5.4-70			
					6			6				
					8			8				
					10			10				
					12			12				
堵头												
	QSC-F...H	-	-	-	-	-	-	4	3 / 5.4-70			
								6				
								8				
								10				
12												
L形	L形快插接头, 360° 旋转 - 外螺纹, 带外六角											
		QSL-F	M5	-	-	4, 6	-	-	-	3 / 5.4-71		
						M7					4, 6	
						-					G1/8	6, 8
						-					G1/4	6, 8, 10, 12
						-					G3/8	8, 10, 12
						-					G1/2	10, 12
	L形快插接头											
		QSL-F	-	-	-	4	-	-	-	3 / 5.4-72		
						6						
8												
10												
12												

快插接头 QS-F, 金属型





产品范围一览

结构特点	型式	型号	接口 D1				接口 D2		→ 页码		
			M 螺纹	R 螺纹	G 螺纹	气管外径	插入套管直径∅	气管外径		插入套管直径∅	
T形	T形快插接头, 360° 旋转 - 外螺纹, 带外六角										
		QST-F	M5	-	-	4, 6	-	-	-	3 / 5.4-73	
			M7			4, 6					
			-			G1/8					6, 8
			-			G1/4					6, 8, 10, 12
			-			G3/8					8, 10, 12
			-			G1/2					10, 12
	T形快插接头										
		QST-F	-	-	-	4	-	4	-	3 / 5.4-74	
						6		6			
8						8					
10						10					
12						12					
	QST-F 变径	-	-	-	6	-	4	-	3 / 5.4-74		
					8		6				
					10		8				
					12		10				
					-		-				
Y形	Y形快插接头										
		QSY-F	-	-	-	6	-	6	-	3 / 5.4-74	
						8		8			
						10		10			
		QSY-F 变径	-	-	-	6	-	4	-	3 / 5.4-74	
						8		6			
						10		8			
-						-					

快插接头 CRQS, 不锈钢型







产品范围一览

FESTO

结构特点	型式	型号	接口 D1				接口 D2			→ 页码
			M 螺纹	R 螺纹	G 螺纹	气管外径	插入套管直径∅	气管外径	插入套管直径∅	
直通结构	快插接头 - 外螺纹, 带内六角									
		CRQS	M5	-	-	4, 6	-	-	-	3 / 5.4-75
			M7	-		4, 6				
			-	R1/8		6, 8				
				R1/4		8, 10				
				R3/8		10, 12				
				R1/2		12, 16				
	穿板式快插接头									
		CRQSS	-	-	-	4	-	-	-	3 / 5.4-76
						6				
						8				
						10				
						12				
						12				
L形	L形快插接头, 360° 旋转 - 外螺纹, 带内六角									
		CRQSL	M5	-	-	4, 6	-	-	-	3 / 5.4-77
			-	R1/8		6, 8				
				R1/4		8, 10				
				R3/8		10, 12				
				R1/2		12, 16				
T形	T形快插接头, 360° 旋转 - 外螺纹, 带内六角									
		CRQST	M5	-	-	4, 6	-	-	-	3 / 5.4-78
			-	R1/8		6, 8				
				R1/4		8, 10				
				R3/8		10, 12				
				R1/2		12, 16				

快插接头 QS-V0, 阻燃型

FESTO

结构特点	型式	型号	接口 D1				接口 D2		→ 页码
			M 螺纹	R 螺纹	G 螺纹	气管外径	插入套管直径 ∅	气管外径	
阻燃, 符合 UL94V0 标准 - 用于塑料气管 PAN/PUN-V0									
直通结构	快插接头 - 外螺纹, 带外六角								
		QS-V0	-	R1/8 R1/4 R3/8 R1/2	G1/8 G1/4 G3/8 G1/2	-	-	6, 8 6, 8, 10, 12 8, 10, 12 10, 12	3 / 5.4-79
快插接头									
	QS-V0	-	-	-	6 8 10 12	-	-	-	3 / 5.4-80
L形	L形快插接头 - 外螺纹, 带外六角								
		QSL-V0	-	R1/8 R1/4 R3/8 R1/2	G1/8 G1/4 G3/8 G1/2	-	-	6, 8 6, 8, 10, 12 8, 10, 12 10, 12	3 / 5.4-81
L形快插接头									
	QSL-V0	-	-	-	6 8 10 12	-	-	-	3 / 5.4-82
T形	T形快插接头 - 外螺纹, 带外六角								
		QST-V0	-	R1/8 R1/4 R3/8 R1/2	G1/8 G1/4 G3/8 G1/2	-	-	6, 8 6, 8, 10, 12 8, 10, 12 10, 12	3 / 5.4-83
T形快插接头									
	QST-V0	-	-	-	6 8 10 12	-	-	-	3 / 5.4-84

快插接头QSM, 小型

技术参数

FESTO

快插接头QSM

外螺纹

带外六角



M 螺纹

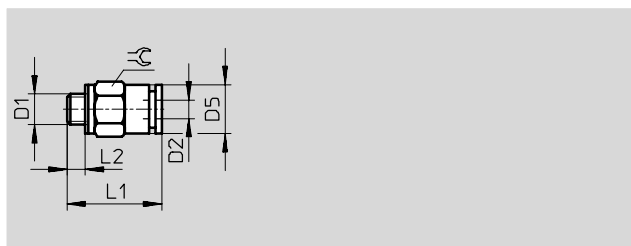

R 螺纹

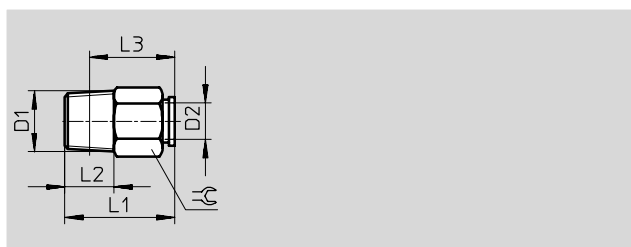

G 螺纹

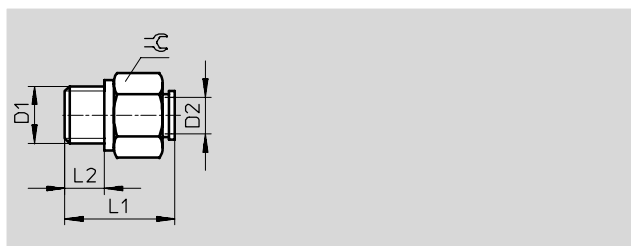

尺寸和订货数据

接口	公称通径	气管外径	D5 ∅	L1	L2	L3	⊕	重量/件	代号	型号	PU*
D1	[mm]	D2						[g]			
公制螺纹, 带密封圈											
M3	1.2	3	5.5	13	3	-	5.5	1	153 301	QSM-M3-3	10
		4	8	16	3	-	8	2	130 775	QSM-M3-3-100	100
	1.2	4	8	16	3	-	8	2	153 303	QSM-M3-4	10
		100	130 776	QSM-M3-4-100	100						
M5	2	3	8	15.5	3.5	-	8	4	153 302	QSM-M5-3	10
		100	130 777	QSM-M5-3-100	100						
	2.4	4	8	16	3.5	-	8	3.5	153 304	QSM-M5-4	10
		100	130 778	QSM-M5-4-100	100						
	2.4	6	10	17.5	3.5	-	10	5	153 306	QSM-M5-6	10
		100	130 779	QSM-M5-6-100	100						
R 螺纹											
R1/8	3	4	-	16	8	12	10	6	153 305	QSM-1/8-4	10
		100	130 755	QSM-1/8-4-100	100						
	4.6	6	-	18	8	14	10	6	153 307	QSM-1/8-6	10
		100	130 756	QSM-1/8-6-100	100						
G 螺纹, 带密封圈											
G1/8	3	4	-	15.9	4.6	-	13	-	186 264	QSM-G1/8-4	10
	100	4.6	6	-	17.9	4.6	13	-	186 265	QSM-G1/8-6	10

* 包装单元内的数量

核心产品

快插接头QSM, 小型

技术参数

FESTO

快插接头 QSM-...-I

外螺纹
带内六角



M 螺纹

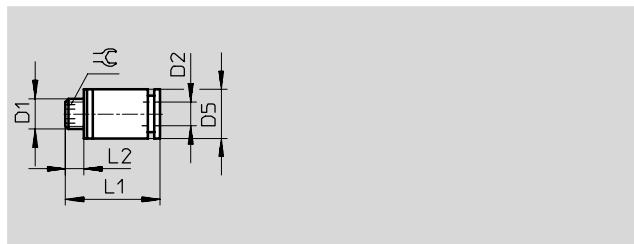

R 螺纹

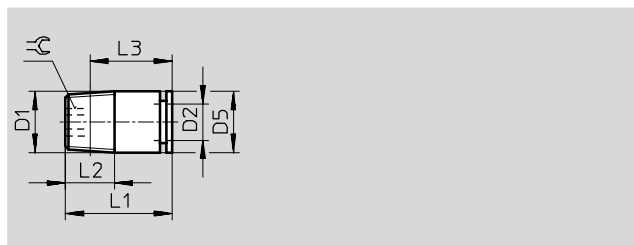

G 螺纹

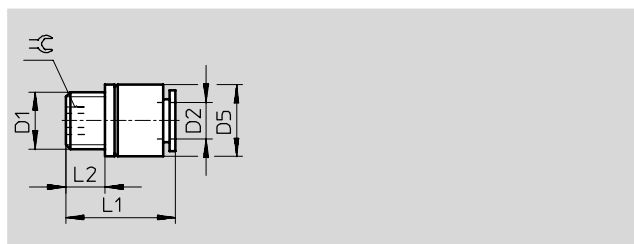

尺寸和订货数据

接口	公称通径	气管外径	D5 ∅	L1	L2	L3	⊕	重量/件	代号	型号	PU*
D1	[mm]	D2						[g]			
公制螺纹, 带密封圈											
M3	1.5	3	8	15.5	3	-	1.5	3	153 312	QSM-M3-3-I	10
	1.5	4	8	16	3	-	1.5	3	153 314	QSM-M3-4-I	10
M5	2.2	3	8	15.5	3.5	-	2	3	153 313	QSM-M5-3-I	10
	2.6	4	8	16.5	3.5	-	2.5	4	153 315	QSM-M5-4-I	10
	2.6	6	9.8	18	3.5	-	2.5	5	153 317	QSM-M5-6-I	10
M7	3.1	4	9.8	18.9	6	-	3	4	153 319	QSM-M7-4-I	10
	4.2	6	9.8	20.9	6	-	4	5	153 321	QSM-M7-6-I	10
R 螺纹											
R ¹ / ₈	3.1	4	10	16	8	11.5	3	6	153 316	QSM-R ¹ / ₈ -4-I	10
	4.2	6	10	18	8	13.5	4	6	153 318	QSM-R ¹ / ₈ -6-I	10
G 螺纹, 带密封圈											
G ¹ / ₈	3.1	4	13	15.9	4.6	-	3	-	186 266	QSM-G ¹ / ₈ -4-I	10
	4.2	6	13	17.9	4.6	-	4	-	186 267	QSM-G ¹ / ₈ -6-I	10

* 包装单元内的数量

核心产品

快插接头QSM, 小型

技术参数

FESTO

快插接头 QSMF

内螺纹
带外六角

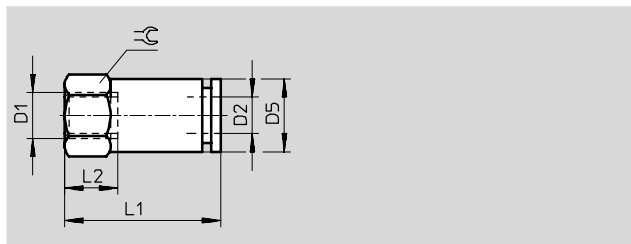

尺寸和订货数据

接口	公称通径	气管外径	D5 ∅	L1	L2	≈C	重量/件	代号	型号	PU*
D1	[mm]	D2					[g]			
公制螺纹, 带密封圈										
M3	2	3	5.5	13	3	5.5	1.5	153 308	QSMF-M3-3	10
	3	4	8	14.5	3	8	3	153 310	QSMF-M3-4	10
M5	2	3	8	15	5	8	4	153 309	QSMF-M5-3	10
	3	4	8	17.5	5	8	4	153 311	QSMF-M5-4	10

* 包装单元内的数量

快插接头 QSMP

外螺纹
内六角

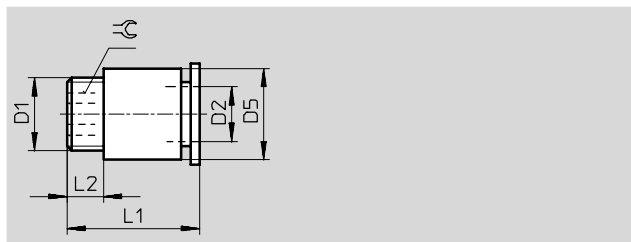

尺寸和订货数据

接口	气管外径	D5 ∅	L1	L2	≈C	重量/件	代号	型号	PU*
D1	D2					[g]			
公制螺纹, 带密封圈									
M6x0.75	4	8	14.5	3.5	2.5	3	153 320	QSMP-M6-4	10
M8x0.75	6	10	15	4	4	4	153 322	QSMP-M8-6	10

* 包装单元内的数量

快插接头QSM, 小型

技术参数

FESTO

快插接头 QSM

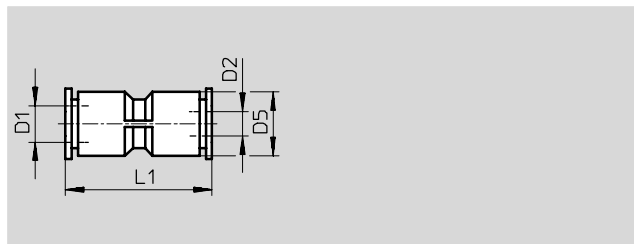

尺寸和订货数据

气管外径 D1	公称通径 [mm]	气管外径 D2	D5 Ø	L1	重量/件 [g]	代号	型号	PU*
3	2	3	6	20	1.5	153 323	QSM-3	10
						130 757	QSM-3-100	100
4	3	4	8	23.5	2	153 324	QSM-4	10
						130 758	QSM-4-100	100
6	4	6	10.5	25	4	153 325	QSM-6	10
						130 759	QSM-6-100	100
变径								
4	2	3	8	23.5	3	153 326	QSM-4-3	10
						130 760	QSM-4-3-100	100
6	3	4	10.5	25	4	153 327	QSM-6-4	10
						130 761	QSM-6-4-100	100

* 包装单元内的数量

5.4 硬管、气管和接头
快插接头

5.4

穿板式快插接头 QSMS

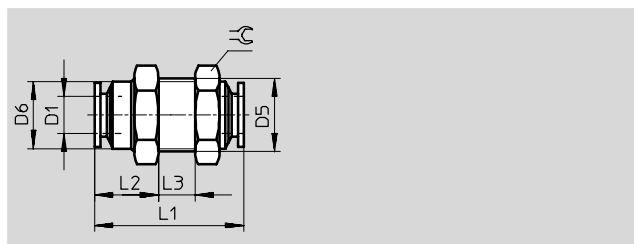

尺寸和订货数据

气管外径 D1	公称通径 [mm]	D5	D6 Ø	L1	L2	L3	≈	重量/件 [g]	代号	型号	PU*
3	2	M8x0.75	7	19.5	7	7.5	10	3	153 375	QSMS-3	10
4	3	M10x1	9	24	9.5	7.5	12	6	153 376	QSMS-4	10
6	4	M12x1	11	25	11	6	14	9	153 377	QSMS-6	10

* 包装单元内的数量

核心产品

快插接头QSM, 小型

技术参数

FESTO

插入式堵头 QSMC

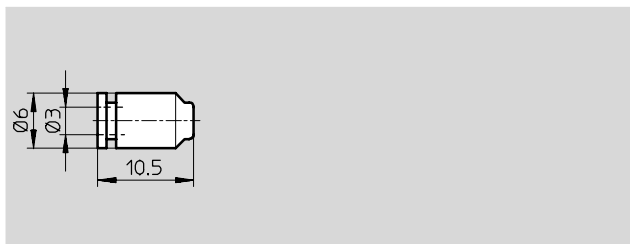

订货数据				
气管外径	重量/件 [g]	代号	型号	PU*
3	0.5	153 381	QSMC-3	10

* 包装单元内的数量

快插接头 QSM-...H 带插入式套管

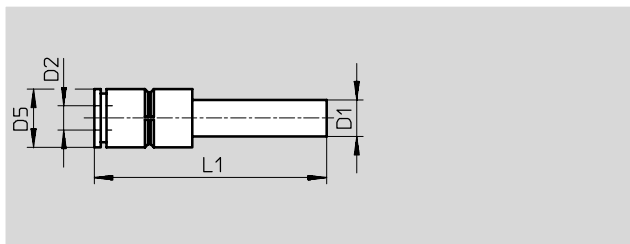

尺寸和订货数据								
气管外径 D2	公称通径 [mm]	插入套管直径 Ø D1	D5 Ø	L1	重量/件 [g]	代号	型号	PU*
3	2.5	4	8	34	1.5	153 328	QSM-4H-3	10
						130 762	QSM-4H-3-100	100
4	3	6	9.5	39	2.5	153 329	QSM-6H-4	10
						130 763	QSM-6H-4-100	100

* 包装单元内的数量

堵头 QSMC-...H

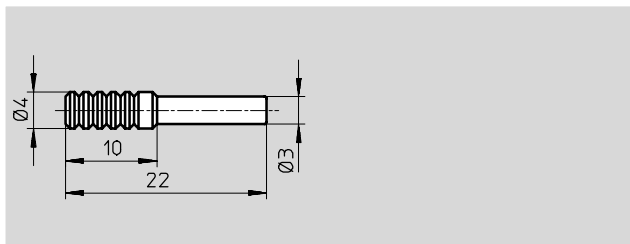

订货数据				
插入套管直径 Ø	重量/件 [g]	代号	型号	PU*
3	0.5	153 382	QSMC-3H	10

* 包装单元内的数量

快插接头QSM, 小型

技术参数

FESTO

L形快插接头 QSML

360° 旋转

外螺纹

带外六角



M 螺纹

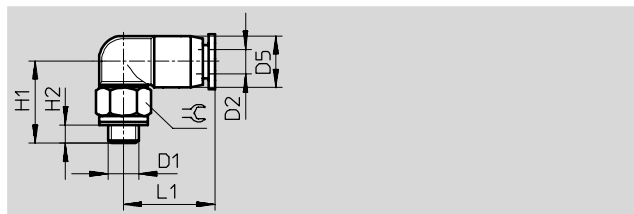

R 螺纹

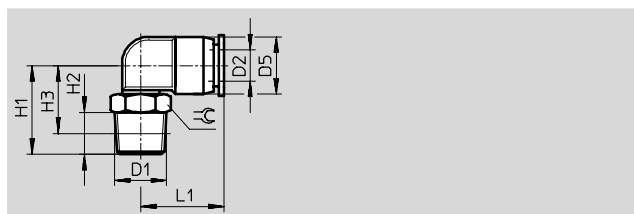

G 螺纹

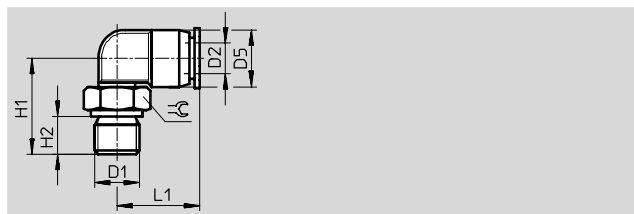

尺寸和订货数据													
接口	公称通径	气管外径	D5	H1	H2	H3	L1	≈C	重量/件	代号	型号	PU*	
D1	[mm]	D2	∅						[g]				
公制螺纹, 带密封圈													
M3	1.2	3	6.5	12	3	-	11	5.5	1.5	153 330	QSML-M3-3	10	
	1.2	4	8.5	14	3	-	15.5	8	3	130 768	QSML-M3-3-100	100	
		3	4	8.5	14	3	-	15.5	8	3	153 332	QSML-M3-4	10
M5	1.2	3	6.5	13.5	3.5	-	11	8	3	130 769	QSML-M3-4-100	100	
		3	6.5	13.5	3.5	-	11	8	3	153 331	QSML-M5-3	10	
	2.4	4	8.5	13.5	3.5	-	15.5	8	3	130 770	QSML-M5-3-100	100	
		4	8.5	13.5	3.5	-	15.5	8	3	153 333	QSML-M5-4	10	
	2.4	6	11	14.5	3.5	-	16.5	8	4	130 771	QSML-M5-4-100	100	
		6	11	14.5	3.5	-	16.5	8	4	153 335	QSML-M5-6	10	
M7	3	4	8	17	6	-	15.7	10	-	130 772	QSML-M5-6-100	100	
		4	8	17	6	-	15.7	10	-	186 352	QSML-M7-4	10	
	4	6	10.5	18	6	-	16.3	10	-	130 773	QSML-M7-4-100	100	
		6	10.5	18	6	-	16.3	10	-	186 353	QSML-M7-6	10	
R 螺纹	R1/8	3	4	8.5	16	8	12	16	10	6	153 334	QSML-1/8-4	10
		4	4	8.5	16	8	12	16	10	6	130 764	QSML-1/8-4-100	100
	4	6	11	17	8	13	16.5	10	7	153 336	QSML-1/8-6	10	
		6	11	17	8	13	16.5	10	7	130 765	QSML-1/8-6-100	100	
G 螺纹, 带密封圈													
G1/8	3	4	8	16	4.6	-	15.7	13	-	186 268	QSML-G1/8-4	10	
	4	6	10.5	17	4.6	-	16.3	13	-	186 269	QSML-G1/8-6	10	

* 包装单元内的数量

核心产品

快插接头QSM, 小型

技术参数

FESTO

L形加长快插接头 QSMLL

360° 旋转

外螺纹

带外六角

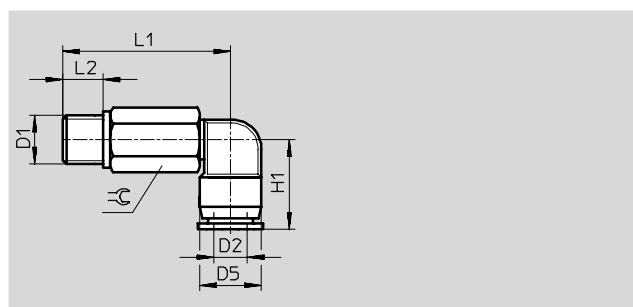
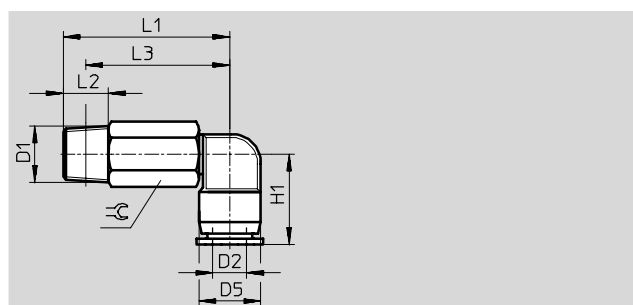
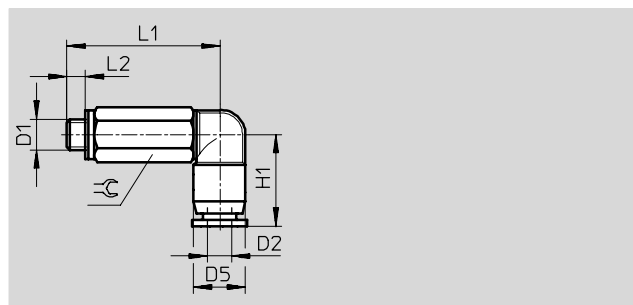

硬管、气管和接头
快插接头

5.4

尺寸和订货数据

接口	公称通径	气管外径	D5 ∅	L1	L2	L3	H1	⌀	重量/件	代号	型号	PU*
D1	[mm]	D2							[g]			
公制螺纹, 带密封圈												
M3	1.2	3	6	19	2.4	-	11	5.5	2.5	153 337	QSMLL-M3-3	10
	1.2	4	8.5	23	2.4	-	15.5	8	7	153 338	QSMLL-M3-4	10
M5	-	3	6	25.5	3.5	-	11	8	7.6	130 838	QSMLL-M5-3	10
	2.4	4	8.5	25	2.9	-	15.5	8	8.5	153 339	QSMLL-M5-4	10
	2.4	6	11	26	2.9	-	16.5	8	9	153 341	QSMLL-M5-6	10
M7	3	4	8	29.5	5.4	-	15.7	10	13	153 354	QSMLL-M7-4	10
	4	6	10.5	30.5	5.4	-	16.3	10	14	153 355	QSMLL-M7-6	10
R 螺纹												
R1/8	4	4	8.5	28.5	8	22	15.5	10	13	153 340	QSMLL-R1/8-4	10
	4	6	11	29.5	8	25.5	16.5	10	14	153 342	QSMLL-R1/8-6	10
G 螺纹, 带密封圈												
G1/8	3	4	8	28.5	4.6	-	15.7	13	-	186 270	QSMLL-G1/8-4	10
	4	6	10.5	29.5	4.6	-	16.3	13	-	186 271	QSMLL-G1/8-6	10

* 包装单元内的数量

快插接头QSM, 小型

技术参数

FESTO

L形快插接头 QSML

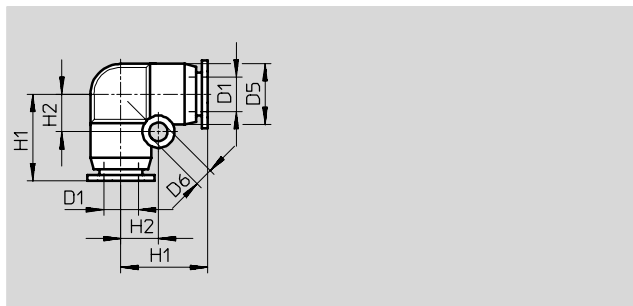

尺寸和订货数据

气管外径 D1	公称通径 [mm]	D5 ∅	D6 ∅	H1	H2	重量/件 [g]	代号	型号	PU*
3	2	6	3.2	11	4.5	1.5	153 343	QSML-3	10
4	3	8	3.2	13.5	5.5	2	153 344	QSML-4	10
							130 766	QSML-4-100	100
6	4	10.5	3.2	15.5	6.5	4	153 345	QSML-6	10
							130 767	QSML-6-100	100

* 包装单元内的数量

L形快插接头 QSML...H

带插入式套管

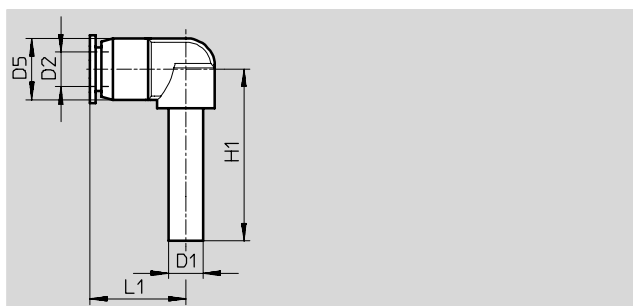

尺寸和订货数据

气管外径 D2	公称通径 [mm]	堵头直径 ∅ D1	D5 ∅	H1	L1	重量/件 [g]	代号	型号	PU*
3	1.5	3	7	21	13	1	153 346	QSML-3H	10
4	2.5	4	8	25.5	15	2	153 347	QSML-4H	10
6	3	6	10.5	29.5	16.5	3	153 348	QSML-6H	10
变径									
3	2.5	4	8.5	25	15	2	153 349	QSML-4H-3	10
4	3	6	10.5	29.5	16.5	3	153 350	QSML-6H-4	10

* 包装单元内的数量

核心产品

快插接头QSM, 小型

技术参数

FESTO

T形快插接头 QSMT

360° 旋转

外螺纹

带外六角



M 螺纹

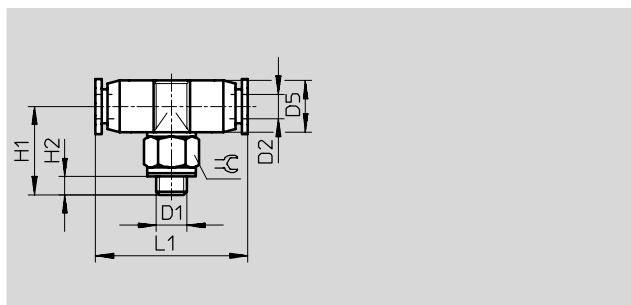

R 螺纹

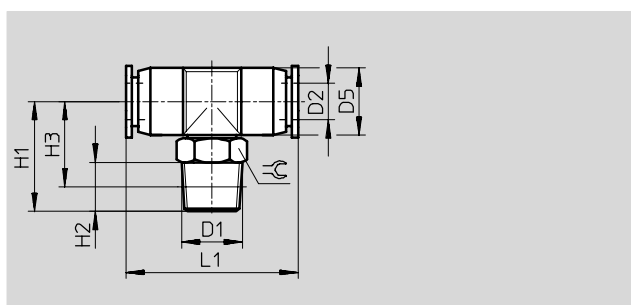

G 螺纹

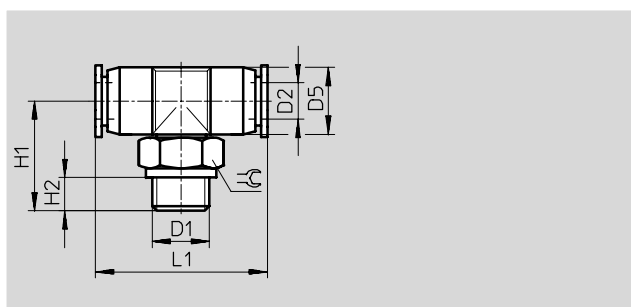

硬管、气管和接头
快插接头

5.4

尺寸和订货数据

接口 D1	公称通径 [mm]	气管外径 D2	D5 ∅	H1	H2	H3	L1	重量/件 [g]	代号	型号	PU*	
公制螺纹, 带密封圈												
M3	1.2	3	6.5	12	3	-	22	5.5	2	153 351	QSMT-M3-3	10
	1.2	4	8.5	15	3	-	27	8	4	153 353	QSMT-M3-4	10
M5	1.2	3	6.5	13.5	3.5	-	22	8	3.5	153 352	QSMT-M5-3	10
	2.4	4	8.5	14.5	3.5	-	27	8	4.5	153 354	QSMT-M5-4	10
											130 784	QSMT-M5-4-100
	2.4	6	11	15.5	3.5	-	30	8	6	153 356	QSMT-M5-6	10
										130 785	QSMT-M5-6-100	100
R 螺纹												
R ¹ / ₈	3	4	8.5	17	8	13	27	10	7	153 355	QSMT-R ¹ / ₈ -4	10
	4	6	11	18	8	14	30	10	8	153 357	QSMT-R ¹ / ₈ -6	10
G 螺纹, 带密封圈												
G ¹ / ₈	5	4	8	17	4.6	-	26.2	13	-	186 272	QSMT-G ¹ / ₈ -4	10
	5	6	10.5	18	4.6	-	28.4	13	-	186 273	QSMT-G ¹ / ₈ -6	10

* 包装单元内的数量

核心产品

快插接头QSM, 小型

技术参数

FESTO

T形快插接头 QSMTL

360° 旋转

外螺纹

带外六角



M 螺纹

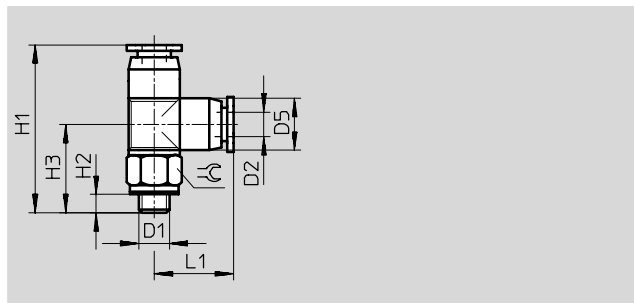

R 螺纹

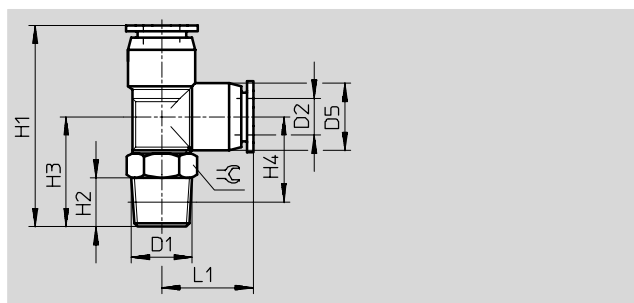

G 螺纹

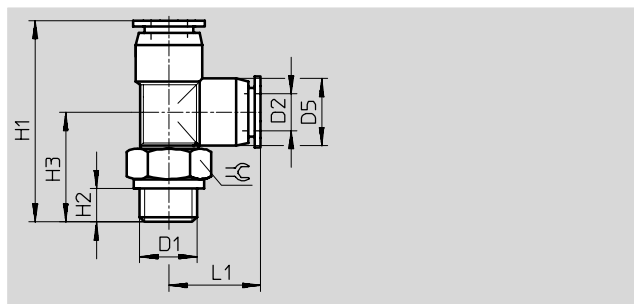

硬管、气管和接头
快插接头

5.4

尺寸和订货数据

接口	公称通径	气管外径	D5	H1	H2	H3	H4	L1	重量/件	代号	型号	PU*	
D1	[mm]	D2	∅						[g]				
公制螺纹, 带密封圈													
M3	1.2	3	6.5	23	3	-	12	11	5.5	2.5	153 358	QSMTL-M3-3	10
	1.2	4	8.5	28.5	3	-	15	13.5	8	4	153 360	QSMTL-M3-4	10
M5	1.2	3	6.5	24.5	3.5	-	13.5	11	8	4.5	153 359	QSMTL-M5-3	10
	2.4	4	8.5	27.5	3.5	-	14.5	13	8	5	153 361	QSMTL-M5-4	10
	2.4	6	10.5	30.5	3.5	-	15.5	15	8	6	153 363	QSMTL-M5-6	10
R 螺纹													
R ¹ / ₈	3	4	8.5	30	8	13	17	13	10	7	153 362	QSMTL- ¹ / ₈ -4	10
	4	6	10.5	33	8	14	18	15	10	8.5	153 364	QSMTL- ¹ / ₈ -6	10
G 螺纹, 带密封圈													
G ¹ / ₈	5	4	8	30.7	4.6	17	-	13.7	13	-	186 274	QSMTL-G ¹ / ₈ -4	10
	5	6	10.5	33.3	4.6	18	-	15.3	13	-	186 275	QSMTL-G ¹ / ₈ -6	10

* 包装单元内的数量

快插接头QSM, 小型

技术参数

FESTO

T形快插接头 QSMT

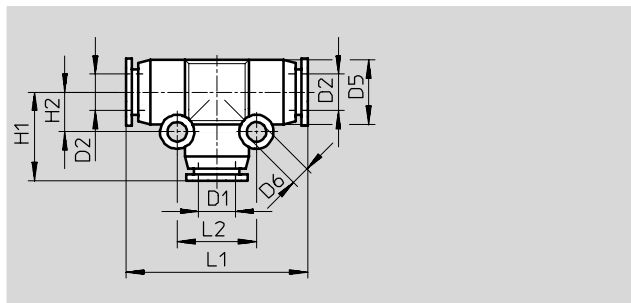

尺寸和订货数据												
气管外径	公称通径	气管外径	D5 ∅	D6 ∅	H1	H2	L1	L2	重量/件	代号	型号	PU*
D1	[mm]	D2							[g]			
3	2	3	6	3.2	11	4.5	22	9	2	153 365	QSMT-3	10
4	3	4	8	3.2	13.5	5.5	27	11	2	153 366	QSMT-4	10
										130 782	QSMT-4-100	100
6	4	6	10.5	3.2	15.5	6.5	31	13	4	153 367	QSMT-6	10
										130 783	QSMT-6-100	100
变径												
3	2.5	4	8	3.2	13	5.5	27	11	3.5	153 368	QSMT-4-3	10
4	3	6	10.5	3.2	15	6.5	30	13	4	153 369	QSMT-6-4	10

* 包装单元内的数量

硬管、气管和接头
快插接头

5.4

核心产品

快插接头QSM, 小型

技术参数

FESTO

X形快插接头QSMX

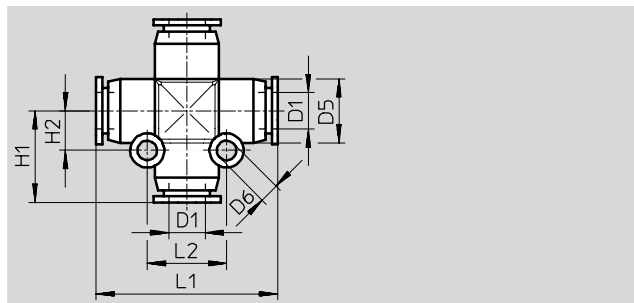

尺寸和订货数据											
气管外径	公称通径	D5	D6	H1	H2	L1	L2	重量/件	代号	型号	PU*
D1	[mm]	∅	∅					[g]			
公制螺纹, 带密封圈											
3	2	8	3.2	13.5	5.5	27	11	4	153 378	QSMX-3	10
4	2.5	8	3.2	13.5	5.5	27	11	4	153 379	QSMX-4	10
6	4	10.5	3.2	15.5	6.5	31	13	5	153 380	QSMX-6	10

* 包装单元内的数量

Y形快插接头 QSMY

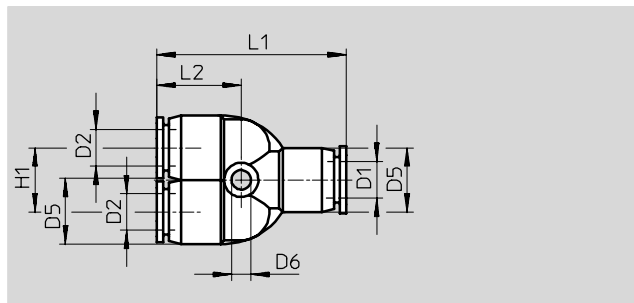

尺寸和订货数据											
气管外径	公称通径	气管外径	D5	D6	L1	L2	H1	重量/件	代号	型号	PU*
D1	[mm]	D2	∅	∅				[g]			
公制螺纹, 带密封圈											
3	2	3	8	3.2	28.5	13	8	3	153 370	QSMY-3	10
4	2	4	8	3.2	29	13	8	3	153 371	QSMY-4	10
									130 786	QSMY-4-100	100
6	3	6	10.5	3.2	31.5	14.5	10.5	5.5	153 372	QSMY-6	10
									130 787	QSMY-6-100	100
变径											
4	1.5	3	8	3.2	28.5	13	8	3	153 373	QSMY-4-3	10
6	3	4	10.5	3.2	31.5	14	10.5	5	153 374	QSMY-6-4	10

* 包装单元内的数量

快插接头 QS

技术参数

FESTO

快插接头 QS

外螺纹

带外六角

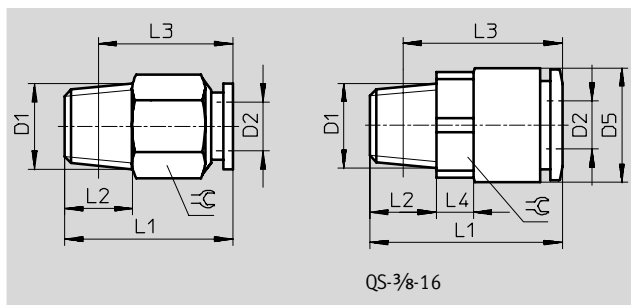

尺寸和订货数据												
接口	公称通径	气管外径	D5	L1	L2	L3	L4	⌀	重量/件 [g]	代号	型号	PU*
D1	[mm]	D2										
R 螺纹												
R1/8	3	4	-	21	8	17	-	10	8.5	153 001	QS-1/8-4	10
										130 674	QS-1/8-4-100	100
	4.6	6	-	22.5	8	18.5	-	12	9	153 002	QS-1/8-6	10
										130 675	QS-1/8-6-100	100
R1/4	6	8	-	28	8	24	-	14	15	153 004	QS-1/8-8	10
										130 676	QS-1/8-8-100	100
	6	10	-	30.3	8	26.3	-	17	22.5	190 643	QS-1/8-10	10
	3	4	-	21	11	15	-	14	16	190 644	QS-1/4-4	10
R1/4	4.6	6	-	24.5	11	18.5	-	14	17	153 003	QS-1/4-6	10
										130 677	QS-1/4-6-100	100
	7	8	-	26.5	11	20.5	-	14		153 005	QS-1/4-8	10
										130 678	QS-1/4-8-50	50
	8.5	10	-	30	11	24	-	17	20	153 007	QS-1/4-10	10
										130 679	QS-1/4-10-50	50
R3/8	11	12	-	36	11	30	-	21	-	164 980	QS-1/4-12	10
										130 680	QS-1/4-12-20	20
	4.6	6	-	23.5	12	17.1	-	17	27	190 645	QS-3/8-6	10
	7	8	-	24	12	17.5	-	17	23	153 006	QS-3/8-8	10
										130 681	QS-3/8-8-50	50
	8.5	10	-	29.5	12	23	-	17	26	153 008	QS-3/8-10	10
R1/2										130 682	QS-3/8-10-50	50
	11	12	-	32	12	25.5	-	21	35.5	153 009	QS-3/8-12	10
										130 683	QS-3/8-12-20	20
	11	16	23.8	46	12	40	10	22	59.5	164 957	QS-3/8-16	1
R1/2	8.5	10	-	30.3	15	22.1	-	21	49	190 646	QS-1/2-10	1
	11	12	-	34	15	26	-	21	49.5	153 010	QS-1/2-12	1
										130 684	QS-1/2-12-20	20
	13	16	-	41.5	15	33.5	-	24	67	153 011	QS-1/2-16	1
									130 685	QS-1/2-16-20	20	

* 包装单元内的数量

硬管、气管和接头
快插接头

5.4

快插接头 QS

技术参数

FESTO

快插接头 QS

外螺纹
带外六角

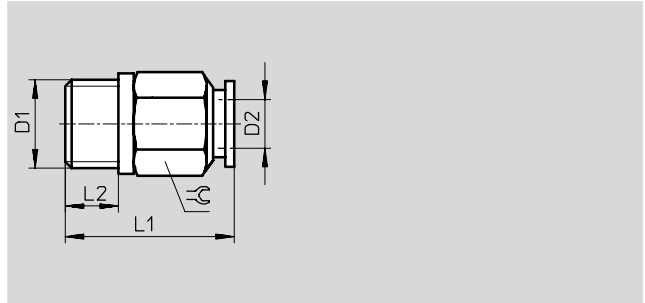

尺寸和订货数据								
接口	公称通径	气管外径	L1	L2	⌀	代号	型号	PU*
D1	[mm]	D2						
G 螺纹, 带密封圈								
G ¹ / ₈	3	4	19.9	4.6	13	186 095	QS-G ¹ / ₈ -4	10
	4.6	6	21	4.6	13	186 096	QS-G ¹ / ₈ -6	10
	6	8	26.2	4.6	14	186 098	QS-G ¹ / ₈ -8	10
G ¹ / ₄	4.6	6	23	6.6	17	186 097	QS-G ¹ / ₄ -6	10
	7	8	23.7	6.6	17	186 099	QS-G ¹ / ₄ -8	10
	8.5	10	30.7	6.6	17	186 101	QS-G ¹ / ₄ -10	10
	11	12	35.9	6.6	21	186 350	QS-G ¹ / ₄ -12	10
G ³ / ₈	7	8	23.9	8.1	19	186 100	QS-G ³ / ₈ -8	10
	8.5	10	27.7	8.1	19	186 102	QS-G ³ / ₈ -10	10
	11	12	33.8	8.1	21	186 103	QS-G ³ / ₈ -12	10
	11	16	39.8	8.1	22	186 347	QS-G ³ / ₈ -16	1
G ¹ / ₂	11	12	32.3	11.1	24	186 104	QS-G ¹ / ₂ -12	1
	13	16	39.8	11.1	24	186 105	QS-G ¹ / ₂ -16	1

* 包装单元内的数量

核心产品

快插接头 QS

技术参数

FESTO

快插接头 QS-...I

外螺纹

带内六角



R 螺纹

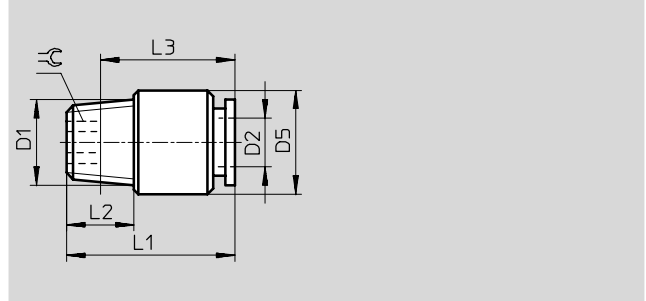

G 螺纹

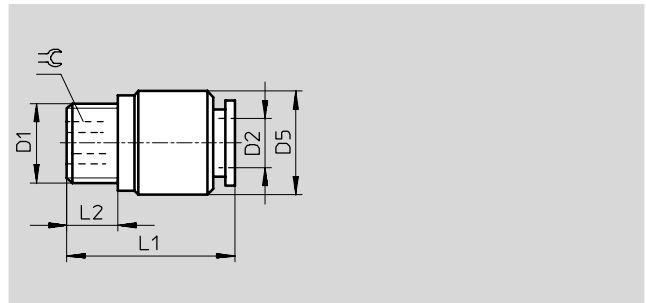

尺寸和订货数据											
接口	公称通径	气管外径	D5 ∅	L1	L2	L3	≈C	重量/件	代号	型号	PU*
D1	[mm]	D2						[g]			
R 螺纹											
R ¹ / ₈	2.6	4	9.5	21	8	17	2.5	8	153 012	QS- ¹ / ₈ -4-I	10
	4.2	6	12	22.5	8	18.5	4	8	153 013	QS- ¹ / ₈ -6-I	10
	5.3	8	13.7	28	8	24	5	14	153 015	QS- ¹ / ₈ -8-I	10
	5.0	10	17.7	30.3	8	26.3	5	25	190 647	QS- ¹ / ₈ -10-I	10
R ¹ / ₄	4.2	6	14	22.5	11	16.5	4	14	153 014	QS- ¹ / ₄ -6-I	10
	6.3	8	14	26.5	11	20.5	6	14.5	153 016	QS- ¹ / ₄ -8-I	10
	6.3	10	17.7	30	11	24	7	22	153 018	QS- ¹ / ₄ -10-I	10
	6.5	12	20.8	35.9	11	29.9	6	40	190 649	QS- ¹ / ₄ -12-I	10
R ³ / ₈	6.3	8	17	24	12	17.5	6	22	153 017	QS- ³ / ₈ -8-I	10
	6.3	10	18	29.5	12	23	6	27	153 019	QS- ³ / ₈ -10-I	10
	8.5	12	21	32	12	25.5	8	33.5	153 020	QS- ³ / ₈ -12-I	10
R ¹ / ₂	6.3	10	20.8	30.3	15	22.1	6	48	190 648	QS- ¹ / ₂ -10-I	1
	8.5	12	21	34	15	26	8	48	153 021	QS- ¹ / ₂ -12-I	1
G 螺纹, 带密封圈											
G ¹ / ₈	2.6	4	13	19.9	4.6	-	2.5	-	186 106	QS-G ¹ / ₈ -4-I	10
	4.2	6	13	22	4.6	-	4	-	186 107	QS-G ¹ / ₈ -6-I	10
	5.3	8	13.7	26.2	4.6	-	5	-	186 109	QS-G ¹ / ₈ -8-I	10
G ¹ / ₄	4.2	6	17	22	6.6	-	4	-	186 108	QS-G ¹ / ₄ -6-I	10
	6.3	8	17	26.2	6.6	-	6	-	186 110	QS-G ¹ / ₄ -8-I	10
	6.3	10	17	30.7	6.6	-	7	-	186 112	QS-G ¹ / ₄ -10-I	10
G ³ / ₈	6.3	8	19	26.2	8.1	-	6	-	186 111	QS-G ³ / ₈ -8-I	10
	6.3	10	19	28.7	8.1	-	7	-	186 113	QS-G ³ / ₈ -10-I	10
	8.5	12	20.8	33.8	8.1	-	8	-	186 114	QS-G ³ / ₈ -12-I	10
G ¹ / ₂	8.5	12	24	32.3	11.1	-	8	-	186 115	QS-G ¹ / ₂ -12-I	1

* 包装单元内的数量

快插接头 QS

技术参数

FESTO

快插接头 QSF

内螺纹
带外六角



G 螺纹

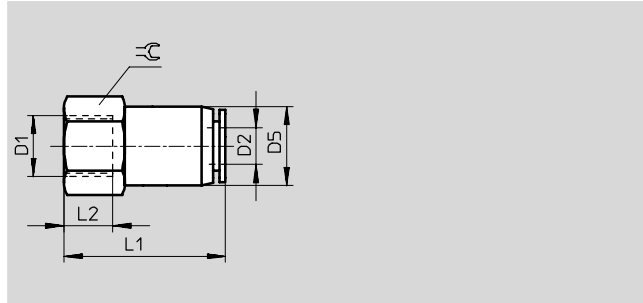

尺寸和订货数据										
接口	公称通径	气管外径	D5	L1	L2	⌀	重量/件	代号	型号	PU*
D1	[mm]	D2	∅				[g]			
G 螺纹, 带密封圈										
G1/8	3	4	11	24.5	8	14	15.5	153 022	QSF-1/8-4-B	10
								130 712	QSF-1/8-4-B-100	100
	4.6	6	13	26.5	8	14	18	153 023	QSF-1/8-6-B	10
								130 713	QSF-1/8-6-B-100	100
	6	8	14.5	28	8	14	19.5	153 025	QSF-1/8-8-B	10
								130 714	QSF-1/8-8-B-50	50
G1/4	3	4	11	27.4	11	17	21.5	190 650	QSF-1/4-4-B	10
	4.6	6	13	29	11	17	25	153 024	QSF-1/4-6-B	10
								130 709	QSF-1/4-6-B-100	100
	6	8	15	31	11	17	27	153 026	QSF-1/4-8-B	10
								130 710	QSF-1/4-8-B-50	50
	8.5	10	17.5	34	11	17	32	153 028	QSF-1/4-10-B	10
							130 711	QSF-1/4-10-B-50	50	
G3/8	11	12	21	35.8	11	21	55.5	190 651	QSF-1/4-12-B	10
	4.6	6	13	30.4	12.5	21	30.5	190 652	QSF-3/8-6-B	10
	6	8	15	32	12	21	36	153 027	QSF-3/8-8-B	10
								130 715	QSF-3/8-8-B-50	50
	8.5	10	17.5	35	12	21	41	153 029	QSF-3/8-10-B	10
								130 716	QSF-3/8-10-B-50	50
G1/2	11	12	21	37	12	21	51.5	153 030	QSF-3/8-12-B	10
								130 717	QSF-3/8-12-B-20	20
	11	12	20.8	40.8	15.8	24	58	190 653	QSF-1/2-12-B	1
	13	16	25	43.8	17	25	79	190 654	QSF-1/2-16-B	1

* 包装单元内的数量

快插接头 QS

技术参数

快插接头 QS

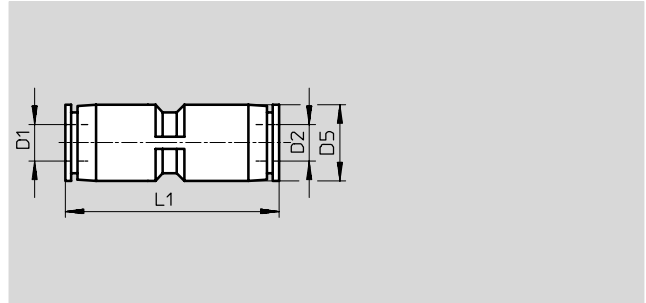

尺寸和订货数据								
气管外径	公称通径	气管外径	D5	L1	重量/件	代号	型号	PU*
D1	[mm]	D2	∅		[g]			
4	3.8	4	10	31	5	153 031	QS-4	10
						130 686	QS-4-100	100
6	5.5	6	12.5	35	6.5	153 032	QS-6	10
						130 687	QS-6-100	100
8	7	8	14.5	38	9.5	153 033	QS-8	10
						130 688	QS-8-50	50
10	9	10	17.5	44	16	153 034	QS-10	10
						130 689	QS-10-50	50
12	11	12	21	48	22	153 035	QS-12	10
						130 690	QS-12-20	20
16	13	16	25	50	25	153 036	QS-16	1
变径								
6	3	4	12.5	34.5	6.5	153 037	QS-6-4	10
						130 691	QS-6-4-100	100
8	-	4	14.5	38.8	11	130 606	QS-8-4	10
						153 038	QS-8-6	10
		6	14.5	38.5	9	130 692	QS-8-6-50	50
10	-	6	17.5	45.2	16	130 607	QS-10-6	10
						153 039	QS-10-8	10
		8	17.5	44	14.5	130 693	QS-10-8-50	50
12	-	8	21	49.4	24	130 608	QS-12-8	10
						153 040	QS-12-10	10
		10	21	53.5	22.5	130 694	QS-12-10-20	20

* 包装单元内的数量

■ 核心产品

快插接头 QS

技术参数

穿板式快插接头 QSS

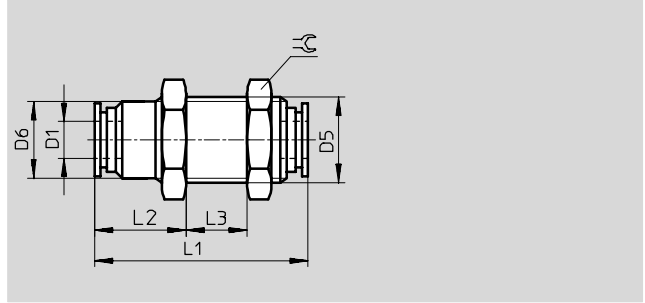

穿板式快插接头

QSS...-F

带固定凸缘

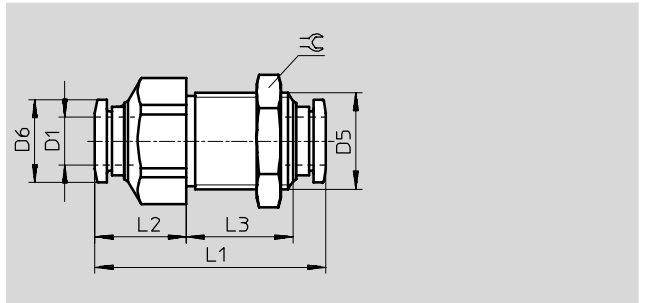

尺寸和订货数据												
气管外径 D1	公称通径 [mm]	D5	D6 ∅	L1	L2	L3	≈	重量/件 [g]	代号	型号	PU*	
4	3	M12x1	11	31	14.5	7	14	10.5	153 157	QSS-4	10	
									130 788	QSS-4-100	100	
6	4.6	M14x1	12.5	35	15	10	17	16	153 158	QSS-6	10	
									130 789	QSS-6-100	100	
8	6	M16x1	14.5	37.5	18	9	19	19.5	153 159	QSS-8	10	
									130 790	QSS-8-50	50	
10	8	M20x1	18.5	43	18.5	13	24	37.5	153 160	QSS-10	10	
									130 791	QSS-10-50	50	
12	11	M22x1	20.5	47	16.5	18	27	56	153 161	QSS-12	10	
									130 792	QSS-12-20	20	
带固定凸缘												
8	-	M16x1	13.8	38.4	15.2	17.7	19	40	130 642	QSS-8-F	新	10
10	-	M20x1	16.8	47.1	20.3	20.9	24	86	130 643	QSS-10-F	新	10
12	-	M22x1	19.8	48.5	18.9	24.1	27	105	130 644	QSS-12-F	新	10

* 包装单元内的数量

快插接头 QS

技术参数

FESTO

穿板式快插接头 QSSF
带内螺纹

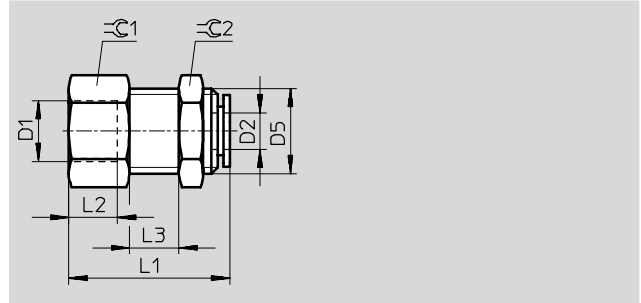

尺寸和订货数据

接口	公称通径	气管外径	D5 ∅	L1	L2	L3	≈∅1	≈∅2	重量/ 件 [g]	代号	型号	PU*
D1	[mm]	D2										
G1/8	3	4	M12x1	25	8	5.5	14	14	18.5	153 162	QSSF-1/8-4-B	10
	6	6	M14x1	27.5	8	7.5	17	17	29.5	153 163	QSSF-1/8-6-B	10
	8	8	M16x1	29	8	11	19	19	38.5	153 165	QSSF-1/8-8-B	10
G1/4	3	4	M12x1	27.5	11	5.5	17	14	24	190 655	QSSF-1/4-4-B	10
	6	6	M14x1	30.5	11	7.5	17	17	29.5	153 164	QSSF-1/4-6-B	10
	8	8	M16x1	32	11	11	19	19	40.5	153 166	QSSF-1/4-8-B	10
	10	10	M20x1	35	11	9.5	24	24	77.5	153 168	QSSF-1/4-10-B	10
G3/8	4.6	6	M14x1	31	12.5	7.5	19	17	24.5	190 656	QSSF-3/8-6-B	10
	8	8	M16x1	33	12	11	19	19	34	153 167	QSSF-3/8-8-B	10
	10	10	M20x1	36	12	9.5	24	24	73	153 169	QSSF-3/8-10-B	10
	12	12	M22x1	39	12	11.5	24	27	85	153 170	QSSF-3/8-12-B	10
G1/2	12	12	M22x1	42	15	11.5	24	27	80	153 171	QSSF-1/2-12-B	1
	13	16	M27x1.5	43	17	7.4	29	32	141	190 657	QSSF-1/2-16	1

* 包装单元内的数量

快插接头 QS

技术参数

插入式堵头 QSC

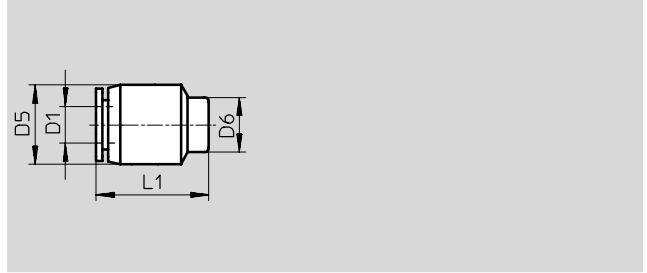

尺寸和订货数据							
气管外径 D1	D5 ∅	D6 ∅	L1	重量/件 [g]	代号	型号	PU*
4	10	7	16.5	2.5	153 262	QSC-4	10
					130 704	QSC-4-100	100
6	13	9	18.5	3.5	153 263	QSC-6	10
					130 705	QSC-6-100	100
8	15	11	20	5	153 264	QSC-8	10
					130 706	QSC-8-50	50
10	18	13	22.5	8	153 265	QSC-10	10
					130 707	QSC-10-50	50
12	21.5	16	23	11.5	153 266	QSC-12	10
					130 708	QSC-12-20	20

* 包装单元内的数量

5.4

快插接头 QS-...H

带插入式套管

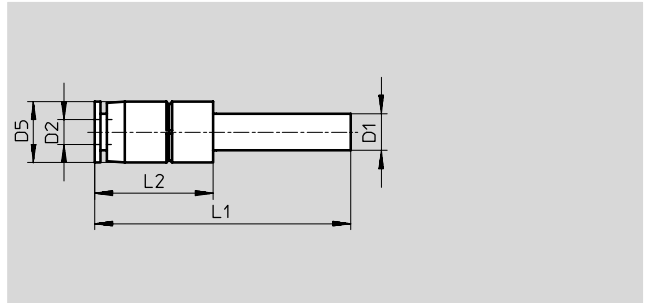

尺寸和订货数据									
气管外径 D2	公称通径 [mm]	插入套管 直径 ∅ D1	D5 ∅	L1	L2	重量/件 [g]	代号	型号	PU*
4	4	6	10	41.5	19.2	3.6	153 041	QS-6H-4	10
		8	12.5	44.2	20.7	4.7	130 695	QS-6H-4-100	100
6	5	8	12.5	44.8	21.3	5	130 622	QS-8H-4	新 10
		10	14.5	46.8	21.8	6.5	153 042	QS-8H-6	10
8	7.5	10	14.5	46.7	21.7	7	130 696	QS-8H-6-50	50
		12	17.5	53.7	25.2	11	130 623	QS-10H-6	新 10
10	9	12	17.5	54.5	25.5	12	153 043	QS-10H-8	10
		14	19.5	56.5	27.5	13	130 697	QS-10H-8-50	50
12	11	14	19.5	56.5	27.5	13	130 624	QS-12H-8	新 10
		16	23.5	60.5	31.5	15	153 044	QS-12H-10	10
							130 698	QS-12H-10-20	20

* 包装单元内的数量

核心产品

快插接头 QS

技术参数

插入式堵头 QSH

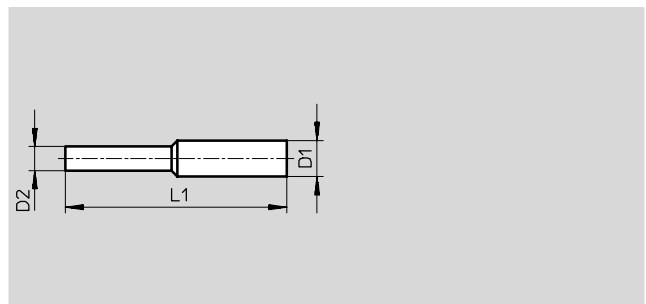
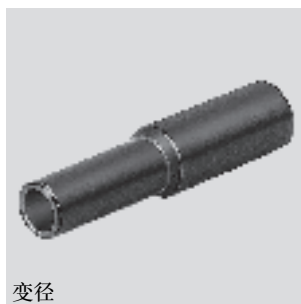
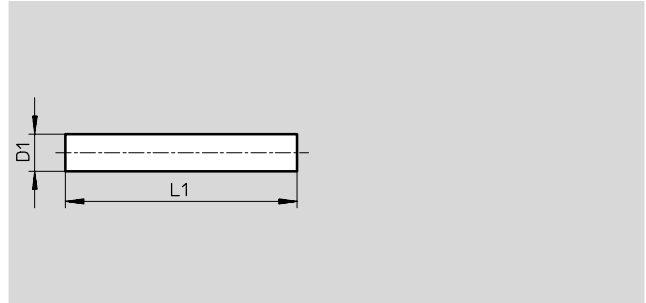

变径

尺寸和订货数据

插入套管直径 ∅ D1	公称通径 [mm]	插入套管直径 ∅ D2	L	重量/件 [g]	代号	型号	PU*
4	2.5	-	35	0.5	153 251	QSH-4	10
					130 723	QSH-4-100	100
6	4	-	38	0.5	153 252	QSH-6	10
					130 724	QSH-6-100	100
8	6	-	41.5	1	153 253	QSH-8	10
					130 725	QSH-8-50	50
10	7.5	-	46	1.5	153 254	QSH-10	10
					130 726	QSH-10-50	50
12	9	-	53	3	153 255	QSH-12	10
					130 727	QSH-12-20	20
16	11	-	55.5	4	153 256	QSH-16	1
变径							
6	2.5	4	36.7	0.5	153 257	QSH-6-4	10
					130 718	QSH-6-4-100	100
8	-	4	41.1	0.9	130 625	QSH-8-4	10
					153 258	QSH-8-6	10
10	6	-	43.7	1.4	130 626	QSH-10-6	10
					153 259	QSH-10-8	10
12	-	8	47.5	2.1	130 627	QSH-12-10	10
					153 260	QSH-12-10	10
16	9	12	54.4	4.2	153 261	QSH-16-12	1
					130 722	QSH-16-12-20	20

* 包装单元内的数量

快插接头 QS

技术参数

FESTO

堵头QSC-...H

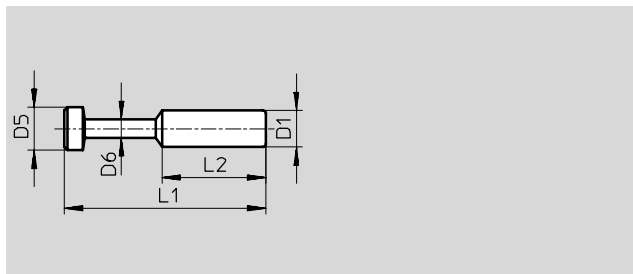

尺寸和订货数据								
插入套管直径 D1	D5 ∅	D6 ∅	L1	L2	重量/件 [g]	代号	型号	PU*
4	5	3	28	15	0.5	153 267	QSC-4H	10
						130 699	QSC-4H-100	100
6	7	3	33	17	0.5	153 268	QSC-6H	10
						130 700	QSC-6H-100	100
8	9	4	37	18	1	153 269	QSC-8H	10
						130 701	QSC-8H-50	50
10	11	5	42	20.5	2	153 270	QSC-10H	10
						130 702	QSC-10H-50	50
12	13	6	44	23	2.5	153 271	QSC-12H	10
						130 703	QSC-12H-20	20
16	17	8	46	24	4	153 272	QSC-16H	10

* 包装单元内的数量

硬管、气管和接头
快插接头

5.4

核心产品

快插接头 QS

技术参数

FESTO

L形快插接头 QSL

360° 旋转

外螺纹

带外六角



R 螺纹

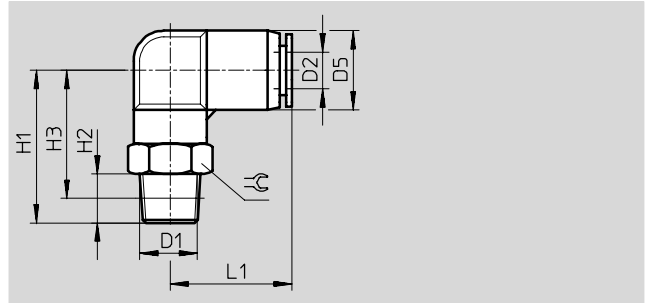

尺寸和订货数据													
接口	公称通径	气管外径	D5	H1	H2	H3	L1	\ominus	重量/件	代号	型号	PU*	
D1	[mm]	D2	\varnothing						[g]				
R 螺纹													
R $\frac{1}{8}$	3	4	10	23.5	8	19.5	18.5	10	12	153 045	QSL- $\frac{1}{8}$ -4	10	
										130 728	QSL- $\frac{1}{8}$ -4-100	100	
	4.6	6	12.5	25	8	21	20	12	14	153 046	QSL- $\frac{1}{8}$ -6	10	
											130 729	QSL- $\frac{1}{8}$ -6-100	100
R $\frac{1}{4}$	6	8	14.5	28	8	24	23	14	18	153 048	QSL- $\frac{1}{8}$ -8	10	
										130 730	QSL- $\frac{1}{8}$ -8-50	50	
	6	10	17.5	33	8	29.1	26.2	17	31	190 658	QSL- $\frac{1}{8}$ -10	10	
R $\frac{1}{4}$	3	4	10	26.3	11	20.3	18	14	21	190 659	QSL- $\frac{1}{4}$ -4	10	
	4.6	6	12.5	28	11	22	20	14	22	153 047	QSL- $\frac{1}{4}$ -6	10	
										130 731	QSL- $\frac{1}{4}$ -6-100	100	
	6	8	14.5	31	11	25	23	14	24	153 049	QSL- $\frac{1}{4}$ -8	10	
										130 732	QSL- $\frac{1}{4}$ -8-50	50	
	8	10	17.5	37	11	30.5	26.5	17	34	153 051	QSL- $\frac{1}{4}$ -10	10	
										130 733	QSL- $\frac{1}{4}$ -10-50	50	
R $\frac{3}{8}$	10	12	21	38	11	32	29.5	21	-	164 981	QSL- $\frac{1}{4}$ -12	10	
										130 734	QSL- $\frac{1}{4}$ -12-20	20	
	4.6	6	12.5	29.8	12	23.7	19.7	17	35	190 660	QSL- $\frac{3}{8}$ -6	10	
	6	8	14.5	33	12	26.5	23	17	37	153 050	QSL- $\frac{3}{8}$ -8	10	
										130 735	QSL- $\frac{3}{8}$ -8-50	50	
	8	10	17.5	40	12	32	26.5	17	42	153 052	QSL- $\frac{3}{8}$ -10	10	
										130 736	QSL- $\frac{3}{8}$ -10-20	20	
R $\frac{1}{2}$	10	12	21	41.5	12	34	29.5	21	51.5	153 053	QSL- $\frac{3}{8}$ -12	10	
										130 737	QSL- $\frac{3}{8}$ -12-20	20	
	11	16	25	47	11	40.5	33.5	22	81.5	164 958	QSL- $\frac{3}{8}$ -16	1	
R $\frac{1}{2}$	8	10	17.5	40	15	31.9	26.2	21	64	190 661	QSL- $\frac{1}{2}$ -10	1	
	10	12	21	33	15	29	29.5	21	66	153 054	QSL- $\frac{1}{2}$ -12	1	
										130 738	QSL- $\frac{1}{2}$ -12	20	
	13	16	25	51	15	43	33.5	22	85.5	153 055	QSL- $\frac{1}{2}$ -16	1	
										130 739	QSL- $\frac{1}{2}$ -16-20	20	

* 包装单元内的数量

快插接头 QS

技术参数

FESTO

L形快插接头 QSL

360° 旋转

外螺纹

带外六角



G 螺纹

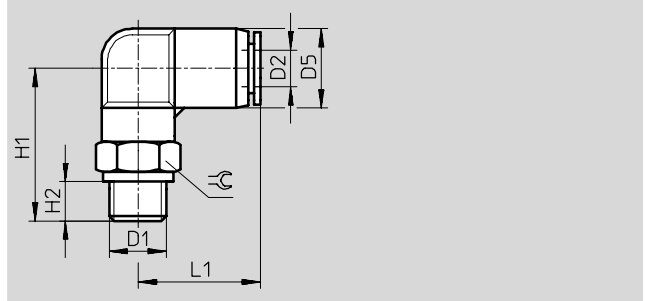

尺寸和订货数据												
接口	公称通径	气管外径	D5	H1	H2	H3	L1	⌀	重量/件	代号	型号	PU*
D1	[mm]	D2	∅						[g]			
G 螺纹, 带密封圈												
G1/8	3	4	10	22.8	4.6	-	18	13	-	186 116	QSL-G1/8-4	10
	4.6	6	12.5	23.5	4.6	-	19.8	13	-	186 117	QSL-G1/8-6	10
	6	8	14.5	26.5	4.6	-	22.7	14	-	186 119	QSL-G1/8-8	10
G1/4	4.6	6	12.5	26.5	6.6	-	19.8	17	-	186 118	QSL-G1/4-6	10
	6	8	14.5	29.5	6.6	-	22.7	17	-	186 120	QSL-G1/4-8	10
	8	10	17.5	33.5	6.6	-	26.2	17	-	186 122	QSL-G1/4-10	10
	10	12	21	35.5	6.6	-	29.4	21	-	186 351	QSL-G1/4-12	10
G3/8	6	8	14.5	31.5	8.1	-	22.7	19	-	186 121	QSL-G3/8-8	10
	8	10	17.5	35.5	8.1	-	26.2	19	-	186 123	QSL-G3/8-10	10
	10	12	21	37.5	8.1	-	29.4	21	-	186 124	QSL-G3/8-12	10
	11	16	25	46.5	8.1	-	33.1	24	-	186 348	QSL-G3/8-16	1
G1/2	10	12	21	42.5	11.1	-	29.4	24	-	186 125	QSL-G1/2-12	1
	13	16	25	49.5	11.1	-	33.1	24	-	186 126	QSL-G1/2-16	1

* 包装单元内的数量

快插接头 QS

技术参数

FESTO

L形加长快插接头 QSL

360° 旋转

外螺纹

带外六角

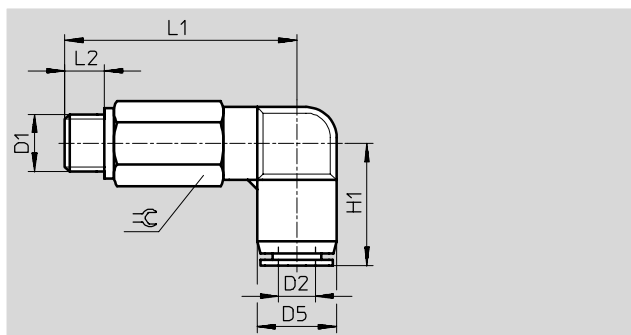
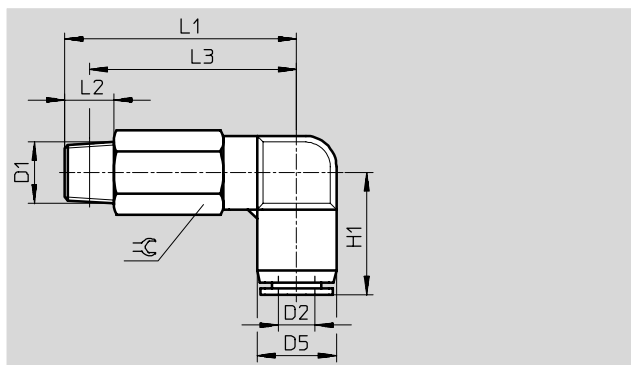

尺寸和订货数据

接口	公称通径	气管外径	D5 ∅	L1	L2	L3	H1	≡C	重量/件	代号	型号	PU*
D1	[mm]	D2							[g]			
R 螺纹												
R ¹ / ₈	3	4	10	37	8	32.5	17	10	18	153 076	QSL- ¹ / ₈ -4	10
	4.6	6	12.5	38	8	34	20	12	26	153 077	QSL- ¹ / ₈ -6	10
	6	8	14.5	43.5	8	39.5	22.5	14	36.5	153 079	QSL- ¹ / ₈ -8	10
R ¹ / ₄	2.8	4	10	38.3	11	32.3	18	14	34	190 662	QSL- ¹ / ₄ -4	10
	4.6	6	12.5	41	11	35	20	14	39	153 078	QSL- ¹ / ₄ -6	10
	6	8	14.5	46.5	11	40.5	22.5	14	42.5	153 080	QSL- ¹ / ₄ -8	10
	8	10	17.5	54.5	11	48.5	26	17	65	153 082	QSL- ¹ / ₄ -10	10
R ³ / ₈	4.6	6	12.5	43.3	12	37.2	19.7	17	61	190 663	QSL- ³ / ₈ -6	10
	6	8	14.5	48.5	12	42	22.5	17	65.5	153 081	QSL- ³ / ₈ -8	10
	8	10	17.5	55.5	12	49	26	17	73	153 083	QSL- ³ / ₈ -10	10
	10	12	21	61	12	54.5	29.5	21	107	153 084	QSL- ³ / ₈ -12	10
R ¹ / ₂	8	10	17.5	60	15	51.9	26.2	21	120	190 664	QSL- ¹ / ₂ -10	1
	10	12	21	64	15	56	29.5	21	122	153 085	QSL- ¹ / ₂ -12	1
G 螺纹												
G ¹ / ₈	3	4	10	33.8	4.6	-	18	13	-	186 127	QSL-G ¹ / ₈ -4	10
	4.6	6	12.5	36.5	4.6	-	19.8	13	-	186 128	QSL-G ¹ / ₈ -6	10
	6	8	14.5	41.5	4.6	-	22.7	14	-	186 130	QSL-G ¹ / ₈ -8	10
G ¹ / ₄	4.6	6	12.5	36.5	6.6	-	19.8	17	-	186 129	QSL-G ¹ / ₄ -6	10
	6	8	14.5	44	6.6	-	22.7	17	-	186 131	QSL-G ¹ / ₄ -8	10
	8	10	17.5	52	6.6	-	26.2	17	-	186 133	QSL-G ¹ / ₄ -10	10
G ³ / ₈	6	8	14.5	46.8	8.1	-	22.7	19	-	186 132	QSL-G ³ / ₈ -8	10
	8	10	17.5	54	8.1	-	26.2	19	-	186 134	QSL-G ³ / ₈ -10	10
	10	12	21	59.5	8.1	-	29.4	21	-	186 135	QSL-G ³ / ₈ -12	10
G ¹ / ₂	10	12	21	62.5	11.1	-	29.4	24	-	186 136	QSL-G ¹ / ₂ -12	1
	13	16	25	76.5	11.1	-	33.1	24	-	190 665	QSL-G ¹ / ₂ -16	1

* 包装单元内的数量

快插接头 QS

技术参数

FESTO

L形快插接头 QSLF

内螺纹
带外六角

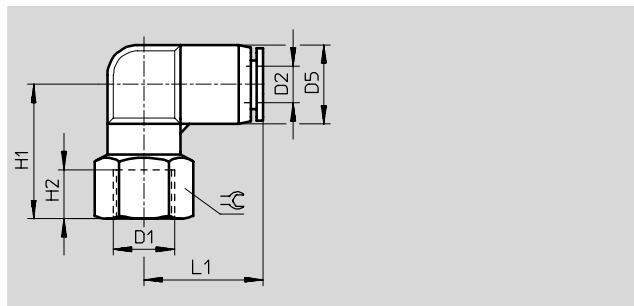

尺寸和订货数据											
接口	公称通径	气管外径	D5	H1	H2	L1	≈	重量/件	代号	型号	PU*
D1	[mm]	D2	∅					[g]			
G 螺纹											
G ¹ / ₈	3	4	10	22.5	8	17	14	14.5	153 273	QSLF- ¹ / ₈ -4-B	10
	4.6	6	12.5	22	8	19.5	14	15.5	153 274	QSLF- ¹ / ₈ -6-B	10
	6	8	14.5	25	8	22.5	14	19	153 276	QSLF- ¹ / ₈ -8-B	10
G ¹ / ₄	4.6	6	12.5	25	11	19.5	17	22	153 275	QSLF- ¹ / ₄ -6-B	10
	6	8	14.5	28	11	22.5	17	25	153 277	QSLF- ¹ / ₄ -8-B	10
	6	10	17.5	32	11	26	19	38.5	153 279	QSLF- ¹ / ₄ -10-B	10
G ³ / ₈	6	8	14.5	29	12	22.5	21	30.5	153 278	QSLF- ³ / ₈ -8-B	10
	6	10	17.5	33	12	26	21	41	153 280	QSLF- ³ / ₈ -10-B	10

* 包装单元内的数量

快插接头 QS

技术参数

FESTO

L形快插接头 QSLV-...I

360° 旋转

外螺纹

带内六角



R 螺纹

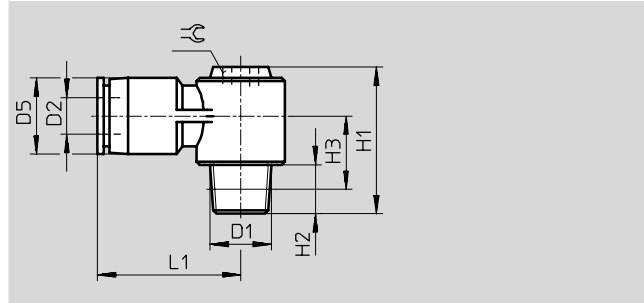

G 螺纹

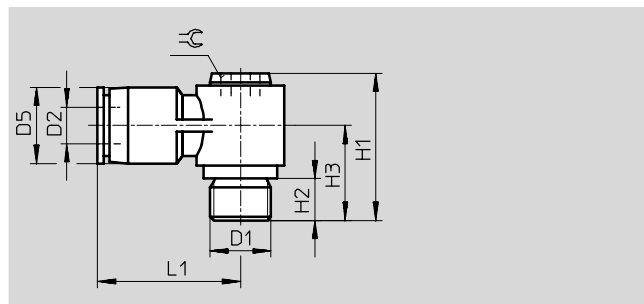

尺寸和订货数据

接口	公称通径	气管外径	D5 ∅	H1	H2	H3	L1	重量/件	代号	型号	PU*	
D1	[mm]	D2						[g]				
R 螺纹												
R ¹ / ₈	4.6	6	13	24	8	11.5	23.5	5	15	153 097	QSLV- ¹ / ₈ -6-I	10
	6	8	14	27	8	12	26.5	8	22	153 099	QSLV- ¹ / ₈ -8-I	10
R ¹ / ₄	4.6	6	13	27	11	12.5	23.5	5	21.5	153 098	QSLV- ¹ / ₄ -6-I	10
	6	8	14	30	11	13	26.5	8	28	153 100	QSLV- ¹ / ₄ -8-I	10
	8	10	18	34	11	14.5	30.5	10	41	153 102	QSLV- ¹ / ₄ -10-I	10
R ³ / ₈	6	8	14	31	12	13.5	26.5	8	36.5	153 101	QSLV- ³ / ₈ -8-I	10
	8	10	18	35	12	15.5	30.5	10	49.5	153 103	QSLV- ³ / ₈ -10-I	10
	10	12	21	39	12	17	36.5	12	68	153 104	QSLV- ³ / ₈ -12-I	10
R ¹ / ₂	10	12	21	42	15	16.5	36.5	12	83	153 105	QSLV- ¹ / ₂ -12-I	1
G 螺纹												
G ¹ / ₈	4.6	6	13	22.5	4.6	14	23.7	5	-	186 148	QSLV-G ¹ / ₈ -6-I	10
	6	8	14	25.5	4.6	14.5	26.7	8	-	186 150	QSLV-G ¹ / ₈ -8-I	10
G ¹ / ₄	4.6	6	13	24.5	6.6	16	23.7	5	-	186 149	QSLV-G ¹ / ₄ -6-I	10
	6	8	14	27.5	6.6	16.5	26.7	8	-	186 151	QSLV-G ¹ / ₄ -8-I	10
	8	10	18	31.5	6.6	18.5	30.7	10	-	186 153	QSLV-G ¹ / ₄ -10-I	10
G ³ / ₈	6	8	14	29.5	8.1	18.5	26.7	8	-	186 152	QSLV-G ³ / ₈ -8-I	10
	8	10	18	33.5	8.1	20.5	30.7	10	-	186 154	QSLV-G ³ / ₈ -10-I	10
	10	12	21	37.5	8.1	22.5	36.4	12	-	186 155	QSLV-G ³ / ₈ -12-I	10
G ¹ / ₂	10	12	21	40.5	11.1	25.5	36.4	12	-	186 156	QSLV-G ¹ / ₂ -12-I	1

* 包装单元内的数量

快插接头 QS

技术参数

FESTO

L形快插接头 QSLV

360° 旋转
外螺纹
带外六角



M 螺纹

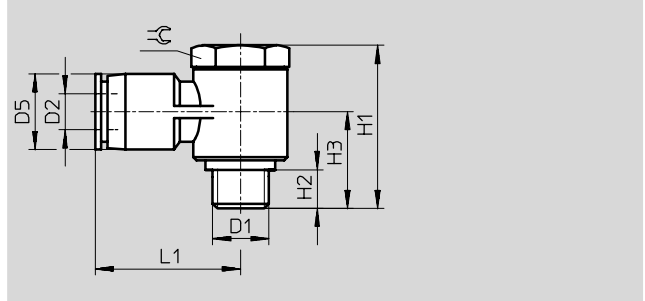

L形快插接头 QSLV

360° 旋转
外螺纹
带外六角



R 螺纹

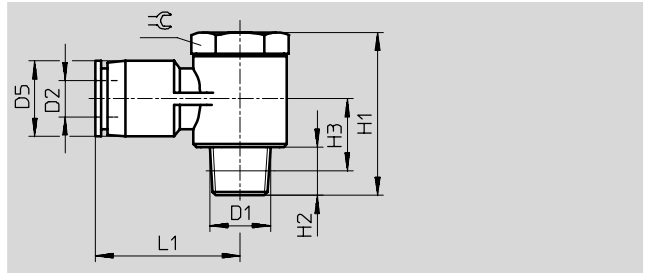

尺寸和订货数据													
接口	公称通径	气管外径	D5 ∅	H1	H2	H3	L1	⌀	重量/件 [g]	代号	型号	PU*	
D1	[mm]	D2											
公制螺纹													
M5	1.8	6	12.5	17.2	2.9	10.4	23	8	85	190 666	QSLV-M-5-6	10	
R 螺纹													
R ¹ / ₈	4	4	10	27	8	12	22.5	14	20	153 086	QSLV- ¹ / ₈ -4	10	
										130 749	QSLV- ¹ / ₈ -4-100	100	
	4	6	12.5	27	8	12	24	14	35.5	153 087	QSLV- ¹ / ₈ -6	10	
										130 750	QSLV- ¹ / ₈ -6-100	100	
R ¹ / ₄	4	8	14.5	27	8	12	26	14	37	153 089	QSLV- ¹ / ₈ -8	10	
										130 751	QSLV- ¹ / ₈ -8-50	50	
	4.6	6	12.5	31.5	11	13.5	27	17	32.5	153 088	QSLV- ¹ / ₄ -6	10	
										130 752	QSLV- ¹ / ₄ -6-100	100	
R ¹ / ₄	5.1	8	14.5	31.5	11	13.5	28.5	17	59.5	153 090	QSLV- ¹ / ₄ -8	10	
										130 753	QSLV- ¹ / ₄ -8-50	50	
	5.1	10	17.5	31.5	11	14.5	30.5	17	62.5	153 092	QSLV- ¹ / ₄ -10	10	
										130 754	QSLV- ¹ / ₄ -10-50	50	
R ³ / ₈	6	8	14.5	36	12	15.5	30.5	21	54.5	153 091	QSLV- ³ / ₈ -8	10	
	6.6	10	17.5	36	12	15.5	33	21	66	153 093	QSLV- ³ / ₈ -10	10	
	6.6	12	21	36	12	17	35	21	97.5	153 094	QSLV- ³ / ₈ -12	10	
R ¹ / ₂	8	12	21	40.5	15	16.5	38	24	100	153 095	QSLV- ¹ / ₂ -12	1	
	8	16	25	48.5	15	22	36.5	24	115	153 096	QSLV- ¹ / ₂ -16	1	

* 包装单元内的数量

快插接头 QS

技术参数

FESTO

L形快插接头 QSLV

360° 旋转

外螺纹

带外六角



G 螺纹

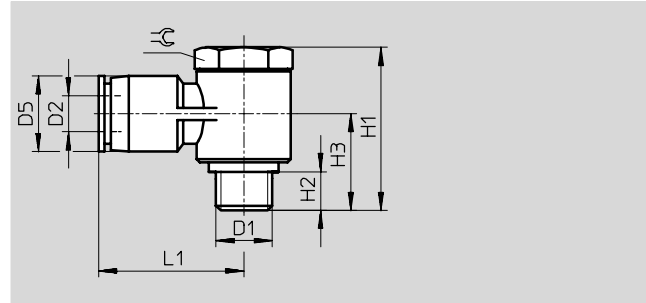

尺寸和订货数据												
接口	公称通径	气管外径	D5	H1	H2	H3	L1	⌀	重量/件	代号	型号	PU*
D1	[mm]	D2	∅						[g]			
G 螺纹												
G ¹ / ₈	4	4	10	23.2	4.6	13.4	23.4	14	-	186 137	QSLV-G ¹ / ₈ -4	10
	4	6	12.4	23.2	4.6	13.4	25.5	14	-	186 138	QSLV-G ¹ / ₈ -6	10
	4	8	14.4	23.2	4.6	13.4	28.4	14	-	186 140	QSLV-G ¹ / ₈ -8	10
G ¹ / ₄	4.6	6	12.4	29.6	6.6	16.8	29	19	-	186 139	QSLV-G ¹ / ₄ -6	10
	5.1	8	14.4	29.6	6.6	16.8	28.9	19	-	186 141	QSLV-G ¹ / ₄ -8	10
	5.1	10	17.6	29.6	6.6	18.1	31.2	19	-	186 143	QSLV-G ¹ / ₄ -10	10
G ³ / ₈	6	8	14.4	34.6	8.1	20.3	31	24	-	186 142	QSLV-G ³ / ₈ -8	10
	6.6	10	17.6	34.6	8.1	20.3	33.6	24	-	186 144	QSLV-G ³ / ₈ -10	10
	6.6	12	21	34.6	8.1	22	36.4	24	-	186 145	QSLV-G ³ / ₈ -12	10
G ¹ / ₂	8	12	21	37.5	11.1	25	37.9	27	-	186 146	QSLV-G ¹ / ₂ -12	1
	8	16	25	46.6	11.1	28	38.1	27	-	186 147	QSLV-G ¹ / ₂ -16	1

* 包装单元内的数量

快插接头 QS

技术参数

FESTO

L形快插接头 QSL

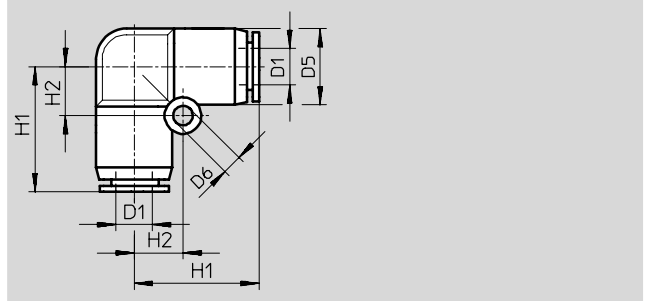

尺寸和订货数据									
气管外径	公称通径	D5	D6	H1	H2	重量/件	代号	型号	PU*
D1	[mm]	∅	∅			[g]			
4	2.8	10	-	17	-	5	153 070	QSL-4	10
							130 740	QSL-4-100	100
6	5	12.5	3.2	20.5	8	7.5	153 071	QSL-6	10
							130 741	QSL-6-100	100
8	7	15	4.2	22	10	10	153 072	QSL-8	10
							130 742	QSL-8-50	50
10	9	17.5	4.2	26	12	17	153 073	QSL-10	10
							130 743	QSL-10-50	50
12	11	21	4.2	29	14	24.5	153 074	QSL-12	10
							130 744	QSL-12-20	20
16	13	25	4.2	33	12	30	153 075	QSL-16	1

* 包装单元内的数量

核心产品

快插接头 QS

技术参数

FESTO

L形快插接头 QSL...H
带插入式套管

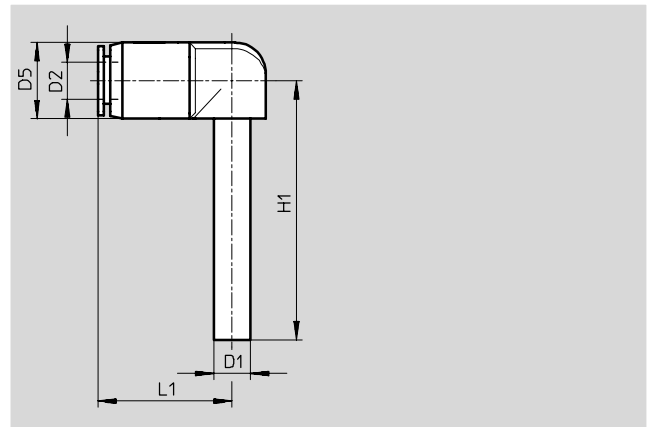
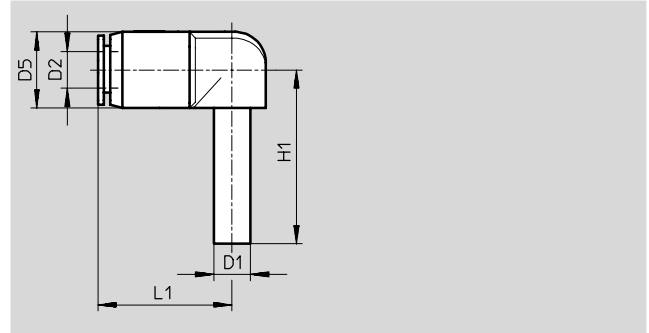

加长插入式套管

尺寸和订货数据									
气管外径 D2	公称通径 [mm]	插入套管直径 ∅ D1	D5 ∅	H1	L1	重量/件 [g]	代号	型号	PU*
4	2.5	4	10	25	20	3.5	153 056	QSL-4H	10
							130 745	QSL-4H-100	100
6	4	6	12.5	28.5	23	5.5	153 057	QSL-6H	10
							130 746	QSL-6H-100	100
8	6	8	14.5	30.5	26	8	153 058	QSL-8H	10
							130 747	QSL-8H-50	50
10	7.5	10	17.5	33.5	30	12.5	153 059	QSL-10H	10
							130 748	QSL-10H-50	50
12	9.5	12	21	38.5	32.5	17.5	153 060	QSL-12H	10
变径									
6	2.5	4	12.5	28.5	22	5.5	153 061	QSL-6H-4	10
8	4	6	14.5	30.5	26	7	153 062	QSL-8H-6	10
10	6	8	17.5	33.5	29	11	153 063	QSL-10H-8	10
12	7.5	10	21	39	32.5	17	153 064	QSL-12H-10	10
加长插入式套管									
4	2.5	4	10	36	20	4	153 065	QSL-4HL	10
6	4	6	12.5	42	23	5.5	153 066	QSL-6HL	10
8	6	8	14.5	46.5	25.5	8.5	153 067	QSL-8HL	10
10	7.5	10	17.5	51.5	29.5	13.5	153 068	QSL-10HL	10
12	9.5	12	21	53	32.5	19.5	153 069	QSL-12HL	10

* 包装单元内的数量

快插接头 QS

技术参数

FESTO

T形快插接头 QST

360° 旋转

外螺纹

带外六角



R 螺纹

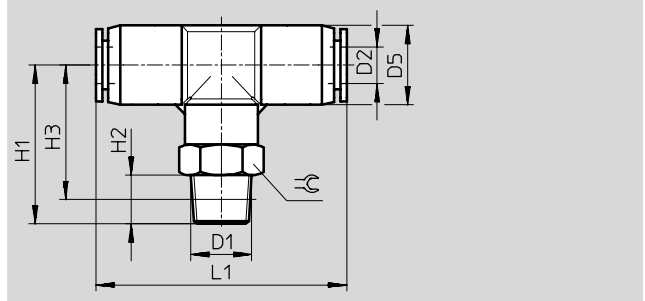

尺寸和订货数据												
接口	公称通径	气管外径	D5	H1	H2	H3	L1	⌀	重量/件	代号	型号	PU*
D1	[mm]	D2	∅						[g]			
R 螺纹												
R1/8	3	4	10	23.5	8	19.5	34	10	14	153 106	QST-1/8-4	10
										130 793	QST-1/8-4-100	100
	4.6	6	13	26	8	22	41	12	17.5	153 107	QST-1/8-6	10
										130 794	QST-1/8-6-100	100
	6	8	15	26.5	8	22.5	45	14	22.5	153 109	QST-1/8-8	10
										130 795	QST-1/8-8-50	50
	6	10	17.5	33	8	29.1	50.4	17	38.5	190 667	QST-1/8-10	10
R1/4	3	4	10	26.3	11	20.3	33.8	14	24	190 668	QST-1/4-4	10
										153 108	QST-1/4-6	10
										130 796	QST-1/4-6-100	100
	6	8	15	29.5	11	23.5	45	14	28	153 110	QST-1/4-8	10
										130 797	QST-1/4-8-50	50
	8	10	17.5	36	11	30	51	17	41.5	153 112	QST-1/4-10	10
										130 798	QST-1/4-10-50	50
	8	12	21	38	11	32	56.8	21	61.5	190 669	QST-1/4-12	10
R3/8	4.6	6	13	30.8	12	24.4	40.2	17	38.5	190 670	QST-3/8-6	10
										153 111	QST-3/8-8	10
										130 799	QST-3/8-8-50	50
	8	10	17.5	37	12	30.5	51	17	50.5	153 113	QST-3/8-10	10
										130 800	QST-3/8-10-20	20
	10	12	21	39	12	32.5	56	21	61.5	153 114	QST-3/8-12	10
										130 801	QST-3/8-12-20	20
	11	16	25	47	11	40.5	67	22	95	164 959	QST-3/8-16	1
R1/2	8	10	17.5	40	15	31.9	50.4	21	72.5	190 672	QST-1/2-10	1
	10	12	21	42	15	34	56	21	77	153 115	QST-1/2-12	1
	13	16	25	51	15	43	67	22	99	153 116	QST-1/2-16	1

* 包装单元内的数量

快插接头 QS

技术参数

FESTO

T形快插接头 QST

360° 旋转

外螺纹

带外六角



G 螺纹

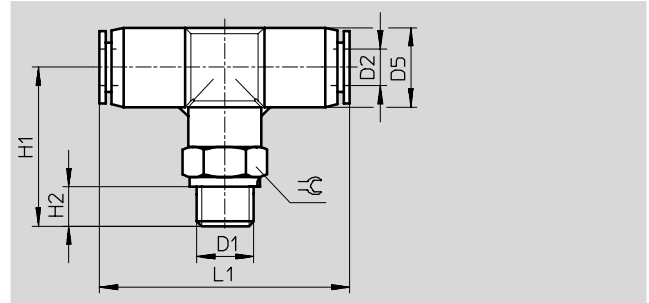

尺寸和订货数据

接口	公称通径	气管外径	D5 ∅	H1	H2	L1	≈	重量/件	代号	型号	PU*
D1	[mm]	D2						[g]			
G 螺纹											
G ¹ / ₈	3	4	10	22.8	4.6	33.8	13	-	186 157	QST-G ¹ / ₈ -4	10
	4.6	6	13	24.5	4.6	40.4	13	-	186 158	QST-G ¹ / ₈ -6	10
	6	8	15	26.5	4.6	44.8	14	-	186 160	QST-G ¹ / ₈ -8	10
G ¹ / ₄	4.6	6	13	27.5	6.6	40.4	17	-	186 159	QST-G ¹ / ₄ -6	10
	6	8	15	29.5	6.6	44.8	17	-	186 161	QST-G ¹ / ₄ -8	10
	8	10	17.5	33.5	6.6	50.4	17	-	186 163	QST-G ¹ / ₄ -10	10
G ³ / ₈	6	8	15	31.5	8.1	44.8	19	-	186 162	QST-G ³ / ₈ -8	10
	8	10	17.5	35.5	8.1	50.4	19	-	186 164	QST-G ³ / ₈ -10	10
	10	12	21	37.5	8.1	56.8	21	-	186 165	QST-G ³ / ₈ -12	10
	11	16	25	46.5	8.1	66.2	24	-	186 349	QST-G ³ / ₈ -16	10
G ¹ / ₂	13	12	21	42.5	11.1	56.8	24	-	186 166	QST-G ¹ / ₂ -12	1
	13	16	25	49.5	11.1	66.2	24	-	186 167	QST-G ¹ / ₂ -16	1

* 包装单元内的数量

核心产品

快插接头 QS

技术参数



T形快插接头 QST

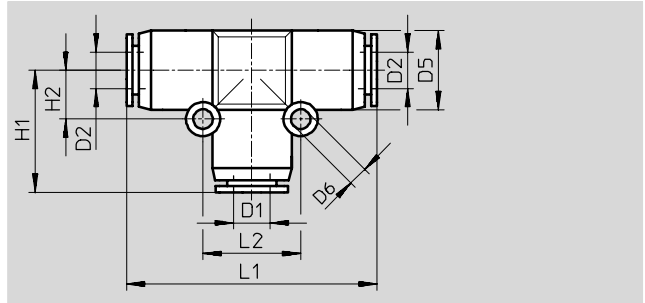

尺寸和订货数据														
气管外径	公称通径	气管外径	D5	D6	H1	H2	L1	L2	重量/件	代号	型号	PU*		
D1	[mm]	D2	∅	∅					[g]					
4	3	4	10	-	17	-	34	-	7	153 128	QST-4	10		
										130 802	QST-4-100	100		
6	4.6	6	13	3.2	20	8	40	16	10.5	153 129	QST-6	10		
										130 803	QST-6-100	100		
8	6	8	15	3.2	22	9	44	18	15.5	153 130	QST-8	10		
										130 804	QST-8-50	50		
10	8	10	18	4.2	25.5	12	51	24	25.5	153 131	QST-10	10		
										130 805	QST-10-50	50		
12	10	12	21.5	4.2	28	14	56	28	36	153 132	QST-12	10		
										130 806	QST-12-20	20		
16	13	16	25.5	4.2	33	12	66	24	43.5	153 133	QST-16	1		
变径														
6	3	4	13	3.2	20	8	41	16	11	153 134	QST-6-4	10		
										130 820	QST-6-4-100	100		
8	-	4	15	3.5	23.2	9	44.4	18	16	130 613	QST-8-4	10	新	
		5	6	15	3.2	20.5	9	45	18	15	153 135	QST-8-6	10	
											130 821	QST-8-6-100	100	
10	-	6	17.5	4.2	27	12	50.4	24	25	130 614	QST-10-6	10	新	
		7	8	17.5	4.2	25	12	51	24	24	153 136	QST-10-8	10	
											130 822	QST-10-8-50	50	
12	-	8	21	4.2	29.8	14	56.8	28	38	130 615	QST-12-8	10	新	
		9	10	21	4.2	29.5	14	59	28	36	153 137	QST-12-10	10	
											130 823	QST-12-10-20	20	
16	-	12	25	4.2	33.2	12	66.2	24	45	130 616	QST-16-12	1	新	

* 包装单元内的数量

核心产品

快插接头 QS

技术参数

FESTO

T形快插接头 QSTF

360° 旋转

带外螺纹和内螺纹



R 螺纹

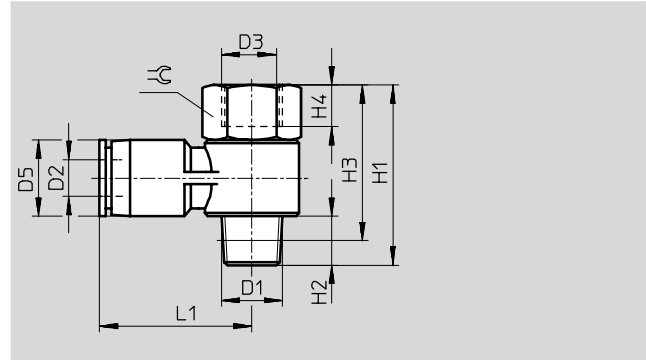

G 螺纹

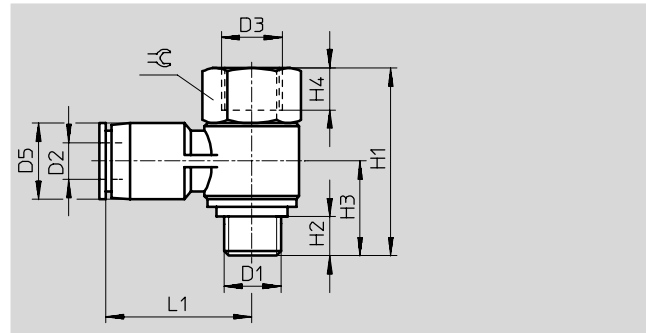

尺寸和订货数据

接口 D1	公称通 径 [mm]	气管外径 D2	D3 ∅	D5 ∅	H1	H2	H3	H4	L1	≈ 重量/件 [g]	代号	型号	PU*	
R 螺纹														
R ¹ / ₈	3	4	G ¹ / ₈	10	32.5	8	28.5	8	22	14	23	153 182	QSTF- ¹ / ₈ -4-B	1
	4.6	6	G ¹ / ₈	12.5	32.5	8	28.5	8	26.5	14	24	153 183	QSTF- ¹ / ₈ -6-B	1
	5	8	G ¹ / ₈	15	32.5	8	28.5	8	26	14	25.5	153 185	QSTF- ¹ / ₈ -8-B	1
R ¹ / ₄	4.6	6	G ¹ / ₄	12.5	38.5	11	32.5	11	26.5	17	39	153 184	QSTF- ¹ / ₄ -6-B	1
	6	8	G ¹ / ₄	15	38.5	11	32.5	11	28	17	40.5	153 186	QSTF- ¹ / ₄ -8-B	1
	6.5	10	G ¹ / ₄	18.5	38.5	11	32.5	11	30.5	17	43.5	153 188	QSTF- ¹ / ₄ -10-B	1
R ³ / ₈	6	8	G ³ / ₈	15	44.5	12	38	12	30	21	65	153 187	QSTF- ³ / ₈ -8-B	1
	8	10	G ³ / ₈	18.5	44.5	12	38	12	32.5	21	68.5	153 189	QSTF- ³ / ₈ -10-B	1
	8.5	12	G ³ / ₈	21.5	44.5	12	38	12	35	21	71.5	153 190	QSTF- ³ / ₈ -12-B	1
R ¹ / ₂	10	12	G ¹ / ₂	21.5	52	13	44	15	38	24	105	153 191	QSTF- ¹ / ₂ -12-B	1
G 螺纹, 带密封圈														
G ¹ / ₈	3	4	G ¹ / ₈	10	25.5	4.6	13.4	7	23.4	14	-	186 199	QSTF-G ¹ / ₈ -4	1
	4.6	6	G ¹ / ₈	12.4	25.5	4.6	13.4	7	25.5	14	-	186 200	QSTF-G ¹ / ₈ -6	1
	5	8	G ¹ / ₈	14.4	25.5	4.6	14.4	7	28.4	14	-	186 202	QSTF-G ¹ / ₈ -8	1
G ¹ / ₄	4.6	6	G ¹ / ₄	12.4	34.2	6.6	16.8	9	29	19	-	186 201	QSTF-G ¹ / ₄ -6	1
	6	8	G ¹ / ₄	14.4	34.2	6.6	16.8	9	28.9	19	-	186 203	QSTF-G ¹ / ₄ -8	1
	6.5	10	G ¹ / ₄	17.6	34.2	6.6	18.1	9	31.2	19	-	186 205	QSTF-G ¹ / ₄ -10	1
G ³ / ₈	6	8	G ³ / ₈	14.4	39.6	8.1	20.3	11	31	24	-	186 204	QSTF-G ³ / ₈ -8	1
	8	10	G ³ / ₈	17.6	39.6	8.1	20.3	11	33.6	24	-	186 206	QSTF-G ³ / ₈ -10	1
	8.5	12	G ³ / ₈	21	39.6	8.1	22	11	36.4	24	-	186 207	QSTF-G ³ / ₈ -12	1
G ¹ / ₂	10	12	G ¹ / ₂	21	46.3	11.1	25	14	37.9	27	-	186 208	QSTF-G ¹ / ₂ -12	1

* 包装单元内的数量

快插接头 QS

技术参数

FESTO

T形快插接头 QSTL

360° 旋转

外螺纹

带外六角



R 螺纹

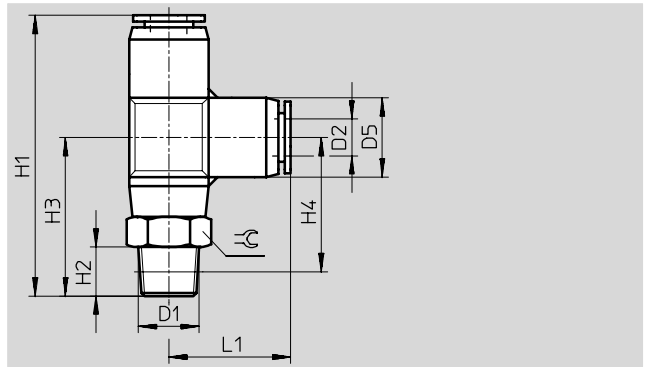

尺寸和订货数据													
接口	公称通径	气管外径	D5 ∅	H1	H2	H3	H4	L1	重量/件	代号	型号	PU*	
D1	[mm]	D2							[g]				
R 螺纹													
R ¹ / ₈	3	4	10	41.5	8	24.5	20.5	17	10	14.5	153 117	QSTL- ¹ / ₈ -4	10
											130 824	QSTL- ¹ / ₈ -4-100	100
	4.6	6	13	46	8	26	22	20	12	17	153 118	QSTL- ¹ / ₈ -6	10
											130 825	QSTL- ¹ / ₈ -6-100	100
R ¹ / ₄	6	8	15	50.5	8	28.5	24	22	14	22.5	153 120	QSTL- ¹ / ₈ -8	10
											130 826	QSTL- ¹ / ₈ -8-50	50
	4.6	6	13	49	11	29	23	20	14	26	153 119	QSTL- ¹ / ₄ -6	10
											130 827	QSTL- ¹ / ₄ -6-100	100
R ³ / ₈	6	8	15	53.5	11	31.5	25	22	14	28.5	153 121	QSTL- ¹ / ₄ -8	10
											130 828	QSTL- ¹ / ₄ -8-50	50
	8	10	17.5	61.5	11	36	30	25.5	17	41.5	153 123	QSTL- ¹ / ₄ -10	10
											130 829	QSTL- ¹ / ₄ -10-50	50
R ³ / ₈	8	10	17.5	62.5	12	37	30.5	25.5	17	50.5	153 122	QSTL- ³ / ₈ -8	10
	10	12	21	67	12	39	32.5	28	21	62.5	153 124	QSTL- ³ / ₈ -10	10
	12	14	25	71	12	41	34.5	30	24	70	153 125	QSTL- ³ / ₈ -12	10
R ¹ / ₂	10	12	21	70	15	42	34	28	21	77.5	153 126	QSTL- ¹ / ₂ -12	1
	13	16	25	84.5	15	51	41	33.5	22	99	153 127	QSTL- ¹ / ₂ -16	1

* 包装单元内的数量

快插接头 QS

技术参数

FESTO

T形快插接头 QSTL

360° 旋转

外螺纹

带外六角



G 螺纹

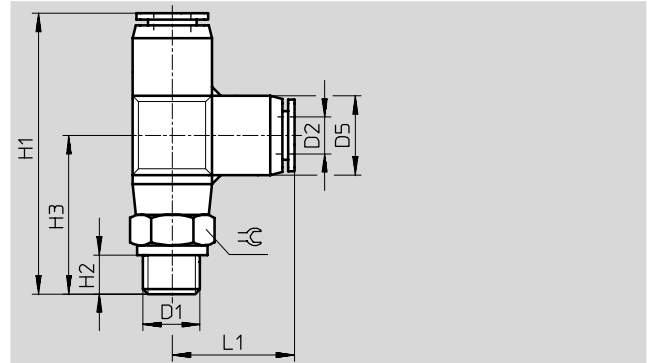

尺寸和订货数据												
接口	公称通径	气管外径	D5	H1	H2	H3	L1		重量/件	代号	型号	PU*
D1	[mm]	D2	∅						[g]			
G 螺纹, 带密封圈												
G ¹ / ₈	3	4	10	39.7	4.6	22.8	16.9	13	-	186 168	QSTL-G ¹ / ₈ -4	10
	4.6	6	13	44.7	4.6	24.5	20.2	13	-	186 169	QSTL-G ¹ / ₈ -6	10
	6	8	15	48.9	4.6	26.7	22.2	14	-	186 171	QSTL-G ¹ / ₈ -8	10
G ¹ / ₄	4.6	6	13	47.7	6.6	27.5	20.2	17	-	186 170	QSTL-G ¹ / ₄ -6	10
	6	8	15	51.9	6.6	29.7	22.2	17	-	186 172	QSTL-G ¹ / ₄ -8	10
	8	10	17.5	58.7	6.6	33.5	25.2	17	-	186 174	QSTL-G ¹ / ₄ -10	10
G ³ / ₈	6	8	15	53.9	8.1	31.7	22.2	19	-	186 173	QSTL-G ³ / ₈ -8	10
	8	10	17.5	60.7	8.1	35.5	25.2	19	-	186 175	QSTL-G ³ / ₈ -10	10
	10	12	21	65.9	8.1	37.7	28.2	21	-	186 176	QSTL-G ³ / ₈ -12	10
G ¹ / ₂	10	12	21	70.9	11.1	42.7	28.2	24	-	186 177	QSTL-G ¹ / ₂ -12	1
	13	16	25	82.6	11.1	49.5	33.1	24	-	186 178	QSTL-G ¹ / ₂ -16	1

* 包装单元内的数量

快插接头 QS

技术参数

弯角式快插接头 QSW

360° 旋转

外螺纹



R 螺纹

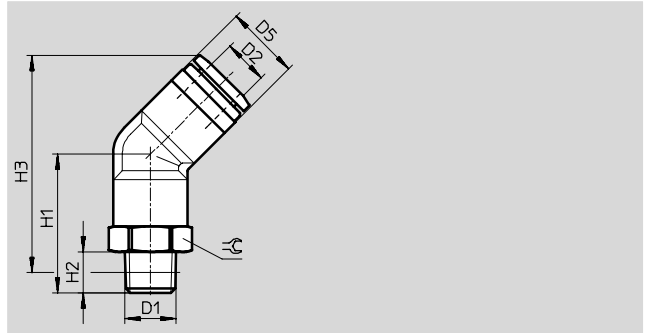

尺寸和订货数据											
接口	公称通径	气管外径	D5	H1	H2	H3	重量/件	代号	型号	PU*	
D1	[mm]	D2					[g]				
R 螺纹											
R ¹ / ₈	-	4	8	14.8	8	23	10	6.1	130 596	QSW- ¹ / ₈ -4	新 10
	-	6	10.5	16.4	8	25.3	10	6.8	130 597	QSW- ¹ / ₈ -6	新 10
	-	8	14.5	27	8	42.2	14	18	130 598	QSW- ¹ / ₈ -8	新 10
R ¹ / ₄	-	6	10.5	21.4	11	28.2	14	17.9	130 599	QSW- ¹ / ₄ -6	新 10
	-	8	14.5	30	11	43.2	14	24	130 600	QSW- ¹ / ₄ -8	新 10
	-	10	17.5	34.2	11	50.6	17	34	130 601	QSW- ¹ / ₄ -10	新 10
R ³ / ₈	-	8	17.5	35.2	12	51.3	17	42	130 602	QSW- ³ / ₈ -10	新 10
	-	10	21	39	12	60	21	66	130 603	QSW- ³ / ₈ -12	新 10
R ¹ / ₂	-	12	21	42	15	61.2	21	80	130 604	QSW- ¹ / ₂ -12	新 1
	-	16	25	47	15	67.6	22	83	130 605	QSW- ¹ / ₂ -16	新 1

* 包装单元内的数量

弯角式快插接头 QSW-...HL

带堵头

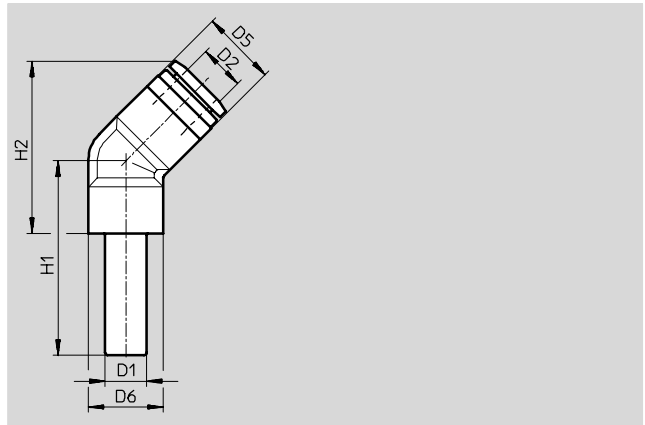

尺寸和订货数据											
接口	公称通径	气管外径	D5	D6	H1	H2	重量/件	代号	型号	PU*	
D1	[mm]	D2					[g]				
4	-	4	8	9.3	25.3	17.5	1.9	130 617	QSW-4HL	新 10	
6	-	6	10.5	10.4	28.5	20.8	3	130 618	QSW-6HL	新 10	
8	-	8	14.5	14.5	37.5	33.2	7.8	130 619	QSW-8HL	新 10	
10	-	10	17.5	17.5	42.2	39.7	13	130 620	QSW-10HL	新 10	
12	-	12	21	21	49.5	48.4	20	130 621	QSW-12HL	新 10	

* 包装单元内的数量

快插接头 QS

技术参数

FESTO

X形快插接头 QSX

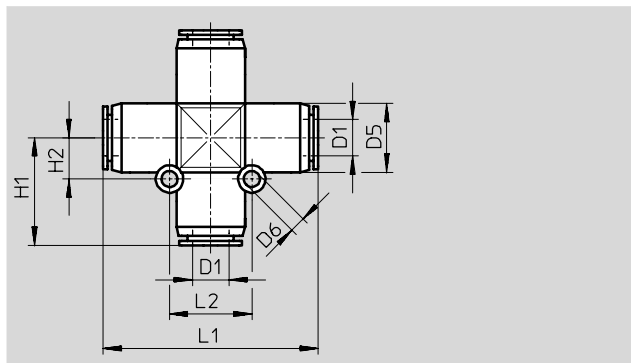

尺寸和订货数据											
气管外径	公称通径	D5	D6	H1	H2	L1	L2	重量/件	代号	型号	PU*
D1	[mm]	∅	∅					[g]			
8	7	15	3.5	23.5	9	47	18	20	153 285	QSX-8	10
10	9	17.5	4.5	27.5	11	55	22	32	153 286	QSX-10	10
12	11	21	4.5	31	12	62	24	46	153 287	QSX-12	10

* 包装单元内的数量

快插接头 QS

技术参数

FESTO

Y形快插接头 QSY

360° 旋转

外螺纹

带外六角



M 螺纹

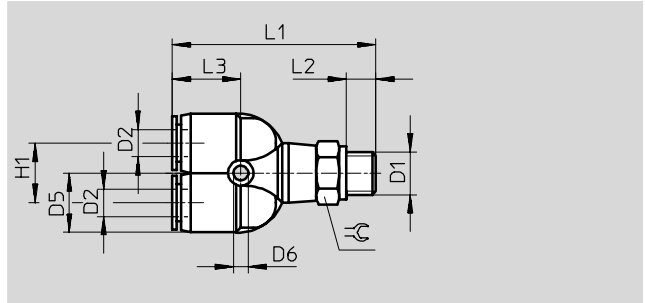

R 螺纹

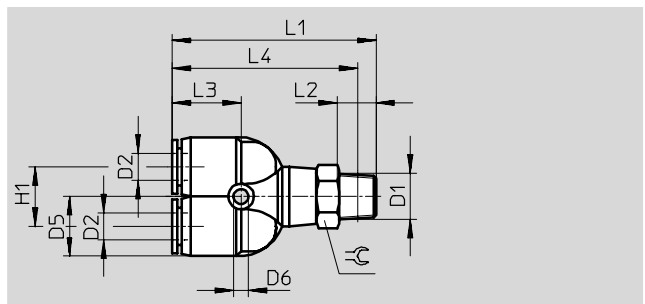

尺寸和订货数据

接口	公称通径	气管外径	D5 ∅	D6 ∅	L1	L2	L3	L4	H1	重量/件 [g]	代号	型号	PU*	
D1	[mm]	D2												
公制螺纹, 带密封圈														
M5	1.8	4	10	3.4	37.4	2.9	13.9	-	11	10	12	190 673	QSY-M5-4	10
	1.8	6	12.5	3.2	41.1	2.9	15.5	-	12	12	16	190 674	QSY-M5-6	10
R 螺纹														
R1/8	3	4	10	3.4	41	8	14.5	38	11	10	15	153 138	QSY-1/8-4	10
	4.6	6	13	3.2	44.5	8	16	40.5	12	12	18	153 139	QSY-1/8-6	10
	6	8	15	3.2	49	8	17.5	45	14	14	23.5	153 141	QSY-1/8-8	10
R1/4	3	4	10	3.4	43.6	11	14.1	37.6	11	14	23	190 675	QSY-1/4-4	10
	4.6	6	13	3.2	47.5	11	16	41.5	12	14	25	153 140	QSY-1/4-6	10
	6	8	15	3.2	52	11	17.5	46	14	14	29.5	153 142	QSY-1/4-8	10
	7.5	10	18	4.5	58.5	11	20	52.5	18	17	43	153 144	QSY-1/4-10	10
R3/8	6	8	15	3.2	53.5	12	17.5	47	14	17	42.5	153 143	QSY-3/8-8	10
	7.5	10	18	4.5	59.5	12	20	53	18	17	51.5	153 145	QSY-3/8-10	10
	9	12	21	4.5	64.5	12	22.5	58	20	21	64.5	153 146	QSY-3/8-12	10
R1/2	9	12	21	4.5	67.5	15	22.5	59.5	20	21	79.5	153 147	QSY-1/2-12	10

* 包装单元内的数量

快插接头 QS

技术参数

FESTO

Y形快插接头 QSY

360° 旋转

外螺纹

带外六角

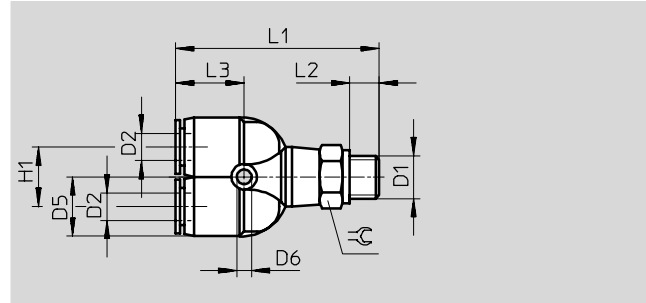

尺寸和订货数据

接口	公称通径	气管外径	D5	D6	L1	L2	L3	H1	⌀	重量/件	代号	型号	PU*
D1	[mm]	D2	∅	∅						[g]			
G 螺纹, 带密封圈													
G ¹ / ₈	3	4	10	3.4	40.1	4.6	14.1	11	13	-	186 179	QSY-G ¹ / ₈ -4	10
	4.6	6	13	3.2	42.9	4.6	15.8	12	13	-	186 180	QSY-G ¹ / ₈ -6	10
	6	8	15	3.2	47.2	4.6	17.2	14	14	-	186 182	QSY-G ¹ / ₈ -8	10
G ¹ / ₄	4.6	6	13	3.2	45.9	6.6	15.8	12	17	-	186 181	QSY-G ¹ / ₄ -6	10
	6	8	15	3.2	50.2	6.6	17.2	14	17	-	186 183	QSY-G ¹ / ₄ -8	10
	7.5	10	18	4.5	55.8	6.6	19.5	18	17	-	186 185	QSY-G ¹ / ₄ -10	10
G ³ / ₈	6	8	15	3.2	52.2	8.1	17.2	14	19	-	186 184	QSY-G ³ / ₈ -8	10
	7.5	10	18	4.5	57.8	8.1	19.5	18	19	-	186 186	QSY-G ³ / ₈ -10	10
	9	12	21.5	4.2	63	8.1	22.2	20	21	-	186 187	QSY-G ³ / ₈ -12	10
G ¹ / ₂	9	12	21.5	4.2	68	11.1	22.2	20	24	-	186 188	QSY-G ¹ / ₂ -12	1

* 包装单元内的数量

快插接头 QS

技术参数

Y形快插接头 QSY

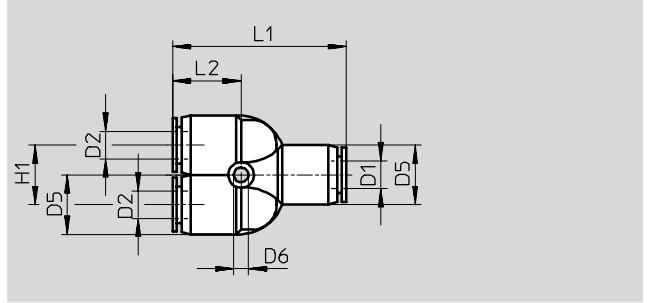

2路变径输出

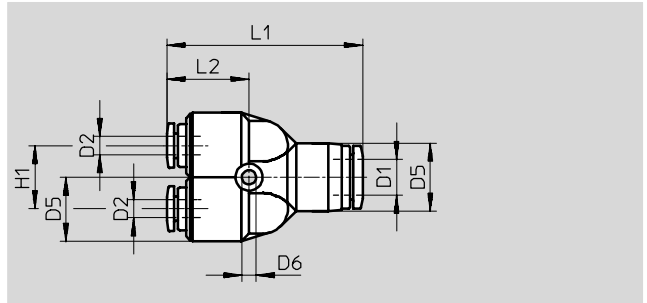

变径

尺寸和订货数据												
气管外径 D1	公称通径 [mm]	气管外径 D2	D5 ∅	D6 ∅	L1	L2	H1	重量/件 [g]	代号	型号	PU*	
4	3	4	10	3.4	32.8	14.1	11	8	153 148	QSY-4	10	
									130 807	QSY-4-100	100	
6	4.6	6	12.5	3.4	37.7	15.8	12	10.5	153 149	QSY-6	10	
									130 808	QSY-6-100	100	
8	6	8	14.5	3.2	42.4	17.2	14	15.5	153 150	QSY-8	10	
									130 809	QSY-8-50	50	
10	7.5	10	18	4.5	48.4	19.5	18	25.5	153 151	QSY-10	10	
									130 810	QSY-10-20	20	
12	9	12	21	4.2	54.8	22.2	20	37	153 152	QSY-12	10	
									130 811	QSY-12-20	20	
16	-	16	25	4.5	62.2	22.1	24	45	130 609	QSY-16	1	
变径												
6	3	4	13	3.2	37.5	15	12	10.5	153 153	QSY-6-4	10	
									130 812	QSY-6-4-100	100	
8	-	4	15	3.2	43.3	18.2	14	17	130 610	QSY-8-4	10	
		4.6	6	15	3.2	42.5	17.5	14	14.5	153 154	QSY-8-6	10
										130 813	QSY-8-6-50	50
10	-	6	18	4.5	50.2	21.3	18	27	130 611	QSY-10-6	10	
		6	8	18	4.5	48.5	19.5	18	23	153 155	QSY-10-8	10
										130 814	QSY-10-8-20	20
12	-	8	21	4.2	56.4	23.8	20	40	130 612	QSY-12-8	10	
		7.5	10	21	4.5	55	22.5	20	35.5	153 156	QSY-12-10	10
										130 815	QSY-12-10-20	20
16	11	12	25	4.5	66.7	26.6	25	77	190 708	QSY-16-12	1	

* 包装单元内的数量

快插接头 QS

技术参数

Y形快插接头 QSY-...H
带插入式套管

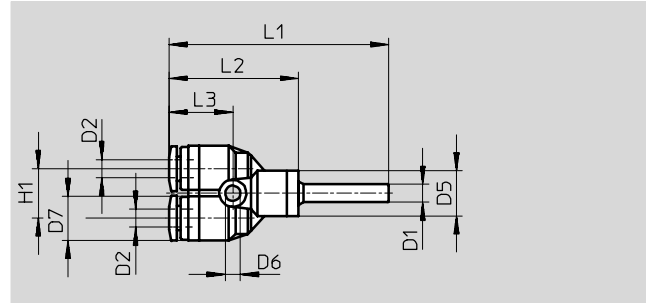

尺寸和订货数据														
插入套管直 径 \varnothing D1	公称通径 [mm]	气管外径 D2	D5 \varnothing	D6 \varnothing	D7 \varnothing	L1	L2	L3	H1	重量/件 [g]	代号	型号		PU*
4	-	4	10	3.4	10	48.7	28.6	14.1	11	6.5	130 628	QSY-4H	· 新	10
6	-	6	12.5	3.2	12.5	55.6	33	15.8	12	9.4	130 629	QSY-6H	· 新	10
8	-	8	13	3.2	14.5	59.2	35.7	17.2	14	13	130 630	QSY-6H	· 新	10
10	-	10	18	4.5	18	68.5	43.5	19.5	18	23	130 631	QSY-10H	· 新	10
12	-	12	21.5	4.5	21	78.3	49.8	22.2	20	34	130 632	QSY-12H	· 新	10
变径														
6	-	4	10	3.4	10	50.9	28.6	14.1	11	6.8	130 633	QSY-6H-4	· 新	10
8	-	6	12.8	3.2	12.5	56.5	33	15.8	12	9.5	130 634	QSY-8H-6	· 新	10
10	-	8	15	3.2	14.5	62.7	37.7	17.2	14	15	130 635	QSY-10H-8	· 新	10
12	-	10	18	4.5	18	69.8	41.3	19.5	18	23	130 636	QSY-12H-10	· 新	10

* 包装单元内的数量

快插接头 QS

技术参数

FESTO

Y形快插接头 QSYL

360° 旋转

外螺纹

带外六角

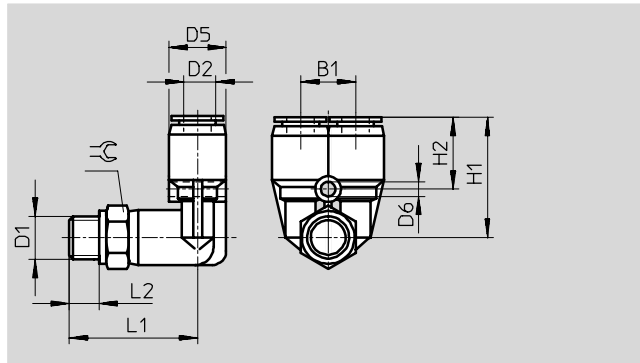
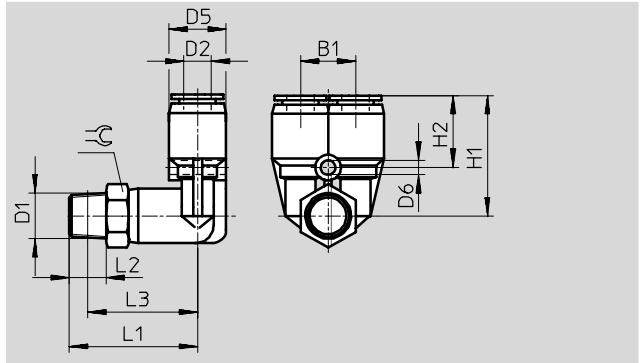

尺寸和订货数据															
接口	公称通径	气管外径	D5	D6	L1	L2	L3	B1	H1	H2	≡	重量/件	代号	型号	PU*
D1	[mm]	D2	∅	∅								[g]			
R 螺纹															
R ¹ / ₈	3	4	10	3.2	24.5	8	20.5	11	23	14.5	10	15.5	153 172	QSYL- ¹ / ₈ -4	1
	4.6	6	13	4.2	28	8	24	12	26.5	16	14	18.5	153 173	QSYL- ¹ / ₈ -6	1
	6	8	15	4.2	31	8	27	14	29.5	17	14	25	153 175	QSYL- ¹ / ₈ -8	1
R ¹ / ₄	4.6	6	13	4.2	31	11	25	12	26.5	16	14	26.5	153 174	QSYL- ¹ / ₄ -6	1
	6	8	15	4.2	34	11	28	14	29.5	17	14	30.5	153 176	QSYL- ¹ / ₄ -8	1
	8	10	18	4.2	37	11	31	18	34	19	17	45	153 178	QSYL- ¹ / ₄ -10	1
R ³ / ₈	6	8	15	4.2	36	12	29.5	14	29.5	17	17	44	153 177	QSYL- ³ / ₈ -8	1
	8	10	18	4.2	38	12	31.5	18	34	19	17	53.5	153 179	QSYL- ³ / ₈ -10	1
	10	12	22	4.2	42	12	35.5	20	35.5	20.5	21	67	153 180	QSYL- ³ / ₈ -12	1
R ¹ / ₂	10	12	22	4.2	45	15	37	20	35.5	20.5	21	83	153 181	QSYL- ¹ / ₂ -12	1
G 螺纹, 带密封圈															
G ¹ / ₈	3	4	10	3.2	24.2	4.6	-	11	22.7	14.5	13	-	186 189	QSYL-G ¹ / ₈ -4	1
	4.6	6	13	4.2	26.5	4.6	-	12	26.2	15.5	13	-	186 190	QSYL-G ¹ / ₈ -6	1
	6	8	15	4.2	29.5	4.6	-	14	29.4	17	14	-	186 192	QSYL-G ¹ / ₈ -8	1
G ¹ / ₄	4.6	6	13	4.2	29.5	6.6	-	12	26.2	15.5	17	-	186 191	QSYL-G ¹ / ₄ -6	1
	6	8	15	4.2	32.5	6.6	-	14	29.4	17	17	-	186 193	QSYL-G ¹ / ₄ -8	1
	8	10	18	4.2	34.5	6.6	-	18	33.5	19	17	-	186 195	QSYL-G ¹ / ₄ -10	1
G ³ / ₈	6	8	15	4.2	34.5	8.1	-	14	29.4	17	19	-	186 194	QSYL-G ³ / ₈ -8	1
	8	10	18	4.2	36.5	8.1	-	18	33.5	19	19	-	186 196	QSYL-G ³ / ₈ -10	1
	10	12	22	4.2	40.7	8.1	-	20	35.2	20.5	21	-	186 197	QSYL-G ³ / ₈ -12	1
G ¹ / ₂	10	12	22	4.2	45.7	11.1	-	20	35.2	20.5	24	-	186 198	QSYL-G ¹ / ₂ -12	1

* 包装单元内的数量

快插接头 QS

技术参数

FESTO

Y形快插接头 QSYLV

360° 旋转

外螺纹

带外六角

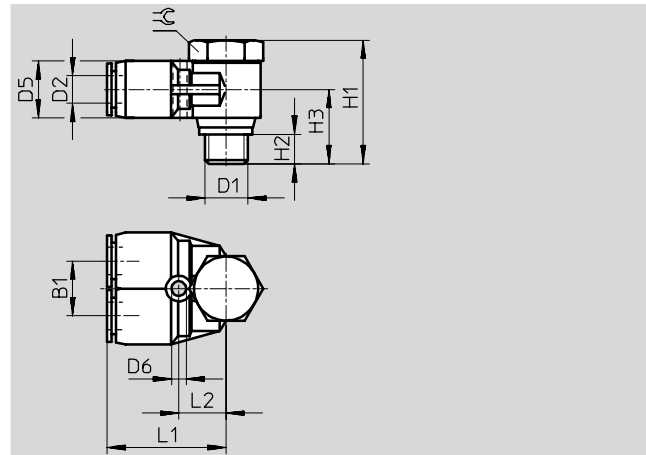
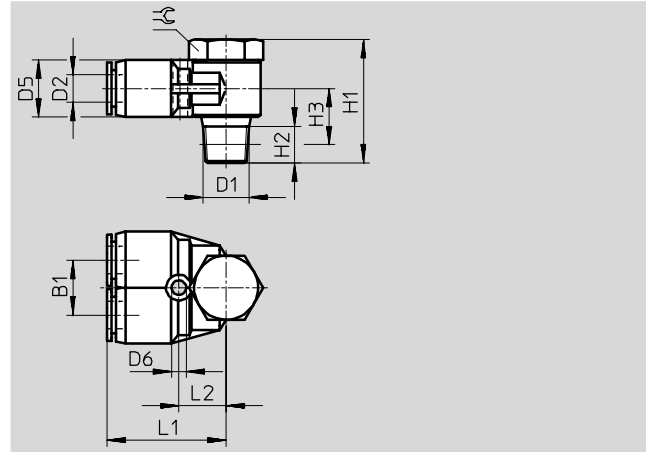

硬管、气管和接头
快插接头

5.4

尺寸和订货数据															
接口	公称通径	气管外径	D5	D6	H1	H2	H3	B1	L1	L2	≡	重量/件	代号	型号	PU*
D1	[mm]	D2	∅	∅								[g]			
R 螺纹															
R ¹ / ₈	4.6	6	12.5	3.2	27	8	11	12	26	10.5	14	24.5	153 192	QSYLV- ¹ / ₈ -6	1
R ¹ / ₄	6	8	14.5	3.2	31.5	11	12.5	14	29	12.5	17	41.5	153 193	QSYLV- ¹ / ₄ -8	1
R ³ / ₈	8	10	17.5	4.2	36	12	14.5	17	33.5	15	21	69.5	153 194	QSYLV- ³ / ₈ -10	1
R ¹ / ₂	10	12	21	4.2	40	15	17.5	20	37.5	17	24	102	153 195	QSYLV- ¹ / ₂ -12	1
G 螺纹, 带密封圈															
G ¹ / ₈	4.6	6	12.4	3.2	25.7	4.6	14.5	12	27.5	12	17	-	186 209	QSYLV-G ¹ / ₈ -6	1
G ³ / ₈	6	8	14.4	3.2	23.9	6.6	17.2	14	30.9	14	19	-	186 210	QSYLV-G ³ / ₈ -8	1
G ³ / ₈	8	10	17.6	4.2	34.9	8.1	20.7	17	34	15.5	21	-	186 211	QSYLV-G ³ / ₈ -10	1
G ¹ / ₂	10	12	21	4.2	40.9	11.1	25.2	20	38.9	18.5	27	-	186 212	QSYLV-G ¹ / ₂ -12	1

* 包装单元内的数量

快插接头 QS

技术参数

FESTO

Y形快插接头 QSYTF

外螺纹和内螺纹
带外六角



R 螺纹

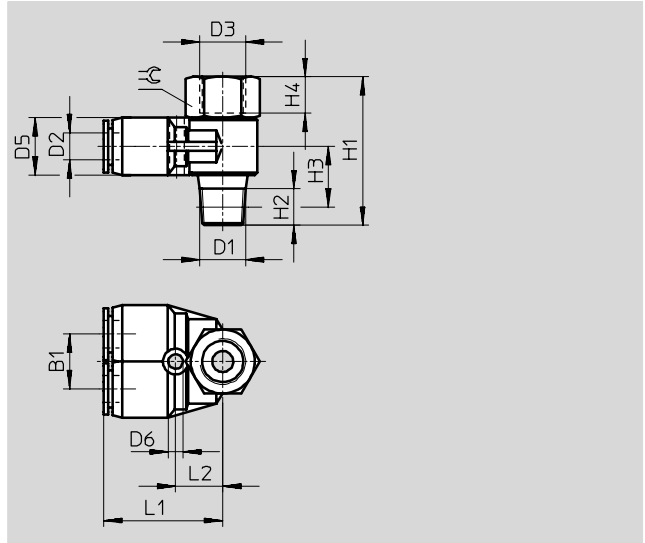

G 螺纹

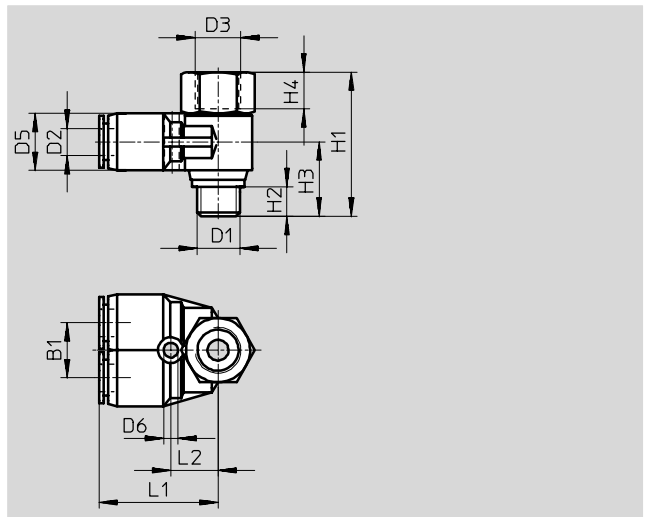

硬管、气管和接头
快插接头

5.4

尺寸和订货数据																	
接口	公称通径	气管外径	D3	D5	D6	H1	H2	H3	H4	B1	L1	L2	≈	重量/件	代号	型号	PU*
D1	[mm]	D2	∅	∅	∅									[g]			
外螺纹R 和内螺纹G																	
R ¹ / ₈	4.6	6	G ¹ / ₈	12.5	3.2	32.5	8	16	8	12	26	10.5	14	27	153 196	QSYTF-1/8-6-B	1
R ¹ / ₄	6	8	G ¹ / ₄	14.5	3.2	38.5	11	19.5	11	14	29	12.5	17	45	153 197	QSYTF-1/4-8-B	1
R ³ / ₈	8	10	G ³ / ₈	18	4.2	44.5	12	26	12	17	33.5	15	21	74.5	153 198	QSYTF-3/8-10-B	1
R ¹ / ₂	10	12	G ¹ / ₂	21.5	4.2	52	13	30.5	15	20	37.5	17	24	106	153 199	QSYTF-1/2-12-B	1
外螺纹G, 带密封圈																	
G ¹ / ₈	4	6	G ¹ / ₈	12.4	3.2	28.7	4.6	12	7	-	27.5	12	17	-	186 213	QSYTF-G ¹ / ₈ -6	1
G ¹ / ₄	6	8	G ¹ / ₄	14.4	3.2	33.9	6.6	14	9	-	30.9	14	19	-	186 214	QSYTF-G ¹ / ₄ -8	1
G ³ / ₈	8	10	G ³ / ₈	17.6	4.2	42.9	8.1	17	11	-	34	15.5	21	-	186 215	QSYTF-G ³ / ₈ -10	1
G ¹ / ₂	10	12	G ¹ / ₂	21	4.2	50.9	11.1	20	14	-	38.9	18.5	27	-	186 216	QSYTF-G ¹ / ₂ -12	1

* 包装单元内的数量

快插接头 QS-F, 金属型

技术参数

FESTO

快插接头 QS-F

外螺纹

带外六角



M 和 G 螺纹

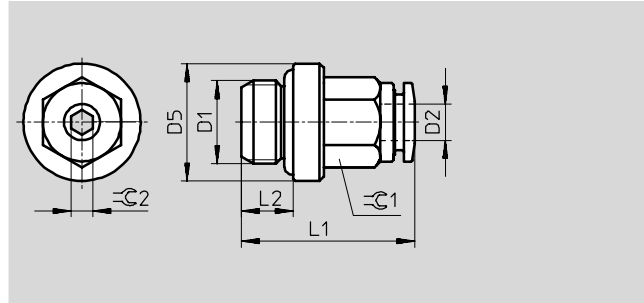

尺寸和订货数据												
接口	公称通径	气管外径	D5	L1	L2	$\approx C1$	$\approx C2$	重量/件	代号	型号		PU*
D1	[mm]	D2	\varnothing					[g]				
公制螺纹												
M5	2.6	4	8	20.5	4	9	2.5	6.1	533 844	QS-F-M5-4	● 新	10
	2.6	6	8	23	4	11	2.5	9.3	533 845	QS-F-M5-6	● 新	10
M7	2.6	4	10.2	22	5.5	9	2.5	6.9	533 846	QS-F-M7-4	● 新	10
	3.6	6	11	25.3	5.5	11	3.5	10.3	533 847	QS-F-M7-6	● 新	10
G 螺纹, 带密封圈												
G $\frac{1}{8}$	2.6	4	13.5	19.5	5.5	9	2.5	8.9	193 408	QS-F-G $\frac{1}{8}$ -4		10
	4.2	6	13.5	24.8	5.5	11	4	12	193 409	QS-F-G $\frac{1}{8}$ -6		10
	5.2	8	12.8	26.5	5.5	13	5	14	193 410	QS-F-G $\frac{1}{8}$ -8		10
G $\frac{1}{4}$	4.2	6	17	22.8	6.5	11	4	16	193 411	QS-F-G $\frac{1}{4}$ -6		10
	6.2	8	17	24	6.5	13	6	16	193 412	QS-F-G $\frac{1}{4}$ -8		10
	7.3	10	16	28.9	6.5	16	7	23.7	193 413	QS-F-G $\frac{1}{4}$ -10		10
	7.3	12	16	31.9	6.5	19	7	32	533 848	QS-F-G $\frac{1}{4}$ -12	● 新	10
G $\frac{3}{8}$	6.2	8	20	24	7.5	13	6	23.3	193 414	QS-F-G $\frac{3}{8}$ -8		10
	8.3	10	21	29.4	7.5	16	8	30	193 415	QS-F-G $\frac{3}{8}$ -10		10
	10.3	12	22	31.9	7.5	19	10	38.1	197 487	QS-F-G $\frac{3}{8}$ -12		10
G $\frac{1}{2}$	8.3	10	24	28.9	9	16	8	42	193 416	QS-F-G $\frac{1}{2}$ -10		1
	10.3	12	24	31.4	9	19	10	46	193 417	QS-F-G $\frac{1}{2}$ -12		1

* 包装单元内的数量

■ 核心产品

快插接头 QS-F, 金属型

技术参数

FESTO

快插接头 QS-F...-I

外螺纹
带内六角



M 和 G 螺纹

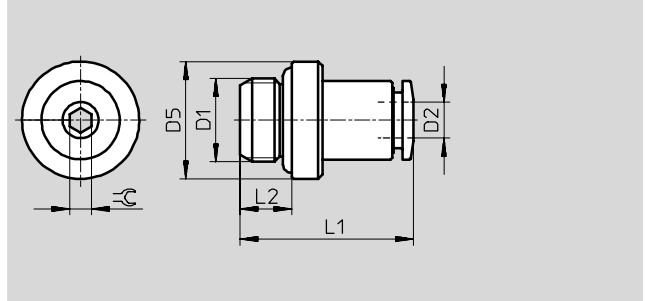

尺寸和订货数据										
接口	公称通径	气管外径	D5	L1	L2	≈	重量/件	代号	型号	PU*
D1	[mm]	D2	∅				[g]			
公制螺纹, 带密封圈										
M5	2.6	4	8	20.5	4	2.5	6	533 924	QS-F-M5-4-I	新 10
	2.6	6	8	23.5	4	2.5	9	537 014	QS-F-M5-6-I	新 10
M7	2.6	4	11	22	5.5	2.5	6.4	533 925	QS-F-M7-4-I	新 10
	4.1	6	11	25.3	5.5	3.5	9.4	533 926	QS-F-M7-6-I	新 10
G 螺纹										
G ¹ / ₈	2.6	4	13	19.5	5.5	2.5	8.6	533 927	QS-F-G ¹ / ₈ -4-I	新 10
	4.2	6	13	24.8	5.5	4	13.4	533 928	QS-F-G ¹ / ₈ -6-I	新 10
	5.2	8	13	26.5	5.5	5	13.1	533 929	QS-F-G ¹ / ₈ -8-I	新 10
G ¹ / ₄	6.2	8	16	24	6.5	6	14.6	533 930	QS-F-G ¹ / ₄ -4-I	新 10
	7.3	10	16	28.9	6.5	7	21	533 931	QS-F-G ¹ / ₄ -10-I	新 10
G ³ / ₈	10.3	12	20	31.9	7.5	10	34.3	533 932	QS-F-G ³ / ₈ -12-I	新 10

* 包装单元内的数量

5.4 硬管、气管和接头 快插接头

快插接头 QSF-F

内螺纹
带外六角



G 螺纹

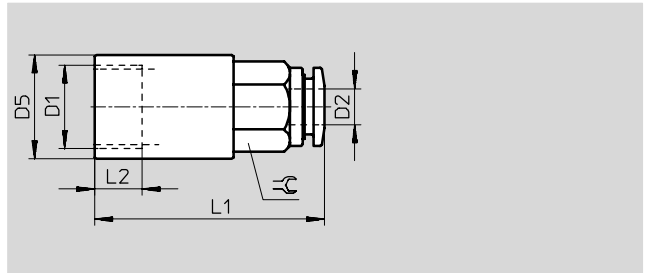

尺寸和订货数据										
接口	公称通径	气管外径	D5	L1	L2	≈	代号	型号	PU*	
D1	[mm]	D2	∅							
G 螺纹										
G ¹ / ₈	3	4	12	26.5	6.8	9	533 854	QSF-F-G ¹ / ₈ -4	新 10	
	3	6	12	28.3	6.8	11	533 856	QSF-F-G ¹ / ₈ -6	新 10	
	5	8	12	28.5	6.8	13	533 858	QSF-F-G ¹ / ₈ -8	新 10	
G ¹ / ₄	5	4	17	29.5	9	9	533 855	QSF-F-G ¹ / ₄ -4	新 10	
	7	6	17	31.3	9	11	533 857	QSF-F-G ¹ / ₄ -6	新 10	
	7	8	17	32.5	9	13	533 859	QSF-F-G ¹ / ₄ -8	新 10	

* 包装单元内的数量

快插接头 QS-F, 金属型

技术参数

穿板式快插接头 QSSF-F
带内六角

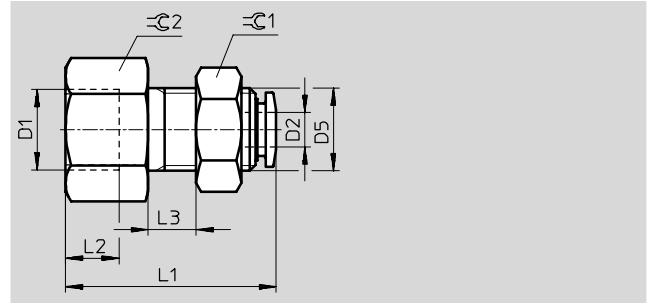

尺寸和订货数据													
接口	公称通径	气管外径	D5	L1	L2	L3	≈C1	≈C2	重量/ 件	代号	型号		PU*
D1	[mm]	D2	∅			最大			[g]				
G 螺纹													
G1/8	3	4	M10x1	25.5	6.8	6.6	13	15	19.7	533 919	QSSF-F-G1/8-4	· 新	10
	5	6	M14x1	26.8	6.8	6.6	17	15	27.8	533 920	QSSF-F-G1/8-6	· 新	10
	7	8	M16x1	29	6.8	6.6	19	17	38.4	533 922	QSSF-F-G1/8-8	· 新	10
G1/4	5	6	M14x1	31.3	9	6.6	17	17	38.3	533 921	QSSF-F-G1/4-6	· 新	10
	7	8	M16x1	33.5	9	6.6	19	17	39.6	533 923	QSSF-F-G1/4-8	· 新	10

* 包装单元内的数量

快插接头 QS-F, 金属型

技术参数

快插接头 QS-F...H
带插入式套管

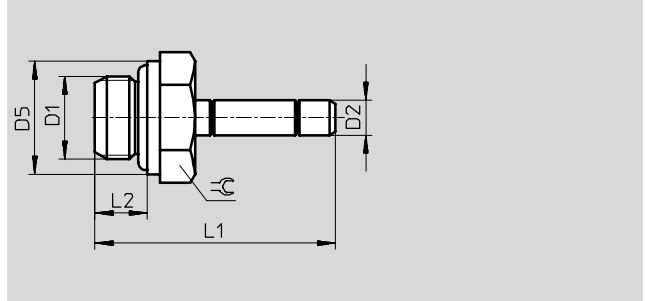

尺寸和订货数据										
接口	公称通径	气管外径	D5	L1	L2	C	代号	型号		PU*
D1	[mm]	D2	∅							
M 螺纹										
M5	2	4	8	24.7	4	8	533 874	QS-F-M5-4H	新	10
	2.6	6	8	27.5	4	8	533 875	QS-F-M5-6H	新	10
M7	2	4	11	26.2	5.5	9	533 876	QS-F-M7-4H	新	10
	3.5	6	11	29	5.5	9	533 877	QS-F-M7-6H	新	10
G 螺纹										
G1/8	2	4	13	27.7	5.5	9	533 878	QS-F-G1/8-4H	新	10
	4	6	13	30.5	5.5	13	533 879	QS-F-G1/8-6H	新	10
	6	8	13	32	5.5	13	533 880	QS-F-G1/8-8H	新	10
G1/4	4	6	16	32	6.5	13	533 881	QS-F-G1/4-6H	新	10
	6	8	16	33.5	6.5	13	533 882	QS-F-G1/4-8H	新	10
	8	10	16	36.5	6.5	13	533 883	QS-F-G1/4-10H	新	10
	8	12	16	37.5	6.5	13	533 884	QS-F-G1/4-12H	新	10
G3/8	6	8	20	35.5	7.5	13	533 885	QS-F-G3/8-8H	新	10
	8	10	20	39.5	7.5	13	533 886	QS-F-G3/8-10H	新	10
	10	12	20	40.5	7.5	13	533 887	QS-F-G3/8-12H	新	10
G1/2	8	10	24	41	9	16	533 888	QS-F-G1/2-8H	新	10
	10	12	24	42	9	16	533 889	QS-F-G1/2-8H	新	1

* 包装单元内的数量

快插接头 QS-F, 金属型

技术参数

FESTO

快插接头 QS-F

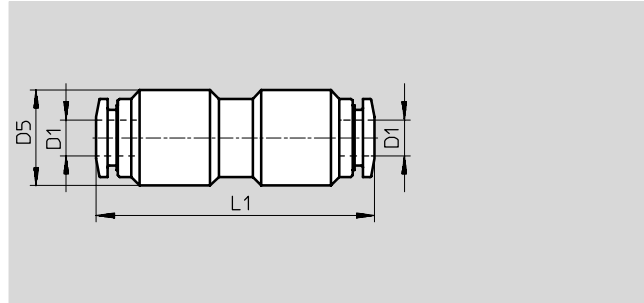

尺寸和订货数据								
气管外径 D1	公称通径 [mm]	D5 ∅	L1	重量/件 [g]	代号	型号		PU*
4	3	11	32	14.3	533 939	QS-F-4	新	10
6	5	14	36.1	22.5	533 940	QS-F-6	新	10
8	7	16	38	29.4	533 941	QS-F-8	新	10
10	9	18	42.3	41.7	533 942	QS-F-10	新	10
12	11	22	45.8	67.9	533 943	QS-F-12	新	10

* 包装单元内的数量

快插接头 QS-F...H

带插入式套管

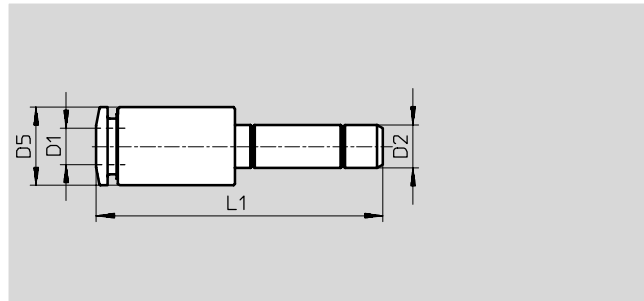

尺寸和订货数据								
气管外径 D1	公称通径 [mm]	插入套管直径 ∅ D2	D5 ∅	L1	代号	型号		PU*
4	2	6	9	32.5	533 895	QS-F-6H-4	新	10
4	2	8	9	34	533 896	QS-F-8H-4	新	10
6	4	8	11	36.3	533 897	QS-F-8H-6	新	10
4	2	10	13	39	533 898	QS-F-10H-4	新	10
6	4	10	11	39.3	533 899	QS-F-10H-6	新	10
8	6	10	13	39	533 900	QS-F-10H-8	新	10
6	4	12	13	40.3	533 901	QS-F-12H-6	新	10
8	6	12	13	39.5	533 902	QS-F-12H-8	新	10
10	8	12	16	41.4	533 903	QS-F-12H-10	新	10

* 包装单元内的数量

快插接头 QS-F, 金属型

技术参数

FESTO

插入式套管 QSH-F

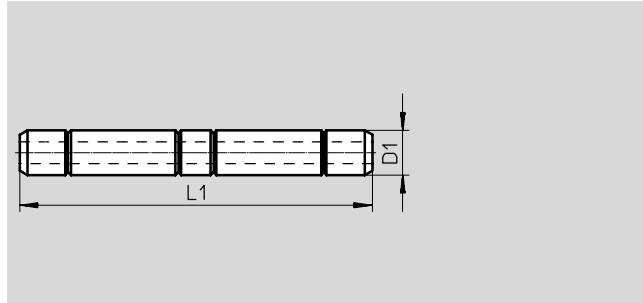

尺寸和订货数据							
插入套管直径 D1	公称通径 [mm]	L1	代号	型号		PU*	
4	2	33.4	533 890	QSH-F-4	新	10	
6	4	39	533 891	QSH-F-6	新	10	
8	6	42	533 892	QSH-F-8	新	10	
10	8	48	533 893	QSH-F-10	新	10	
12	10	50	533 894	QSH-F-12	新	10	

* 包装单元内的数量

堵头 QSC-F...H

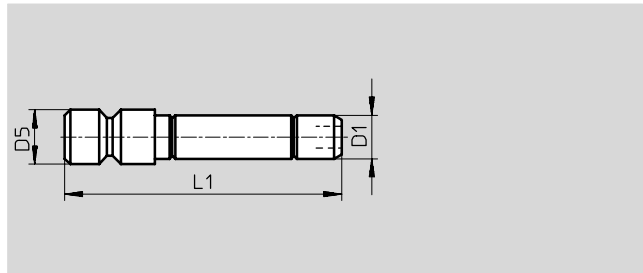

尺寸和订货数据							
插入套管直径 D1	D5 Ø	L1	代号	型号		PU*	
4	5	26	533 904	QSC-F-4H	新	10	
6	7	29	533 905	QSC-F-6H	新	10	
8	9	31.5	533 906	QSC-F-8H	新	10	
10	11	35	533 907	QSC-F-10H	新	10	
12	13	37	533 908	QSC-F-12H	新	10	

* 包装单元内的数量

快插接头 QS-F, 金属型

技术参数

L形快插接头 QSL-F

360° 旋转

外螺纹

带外六角

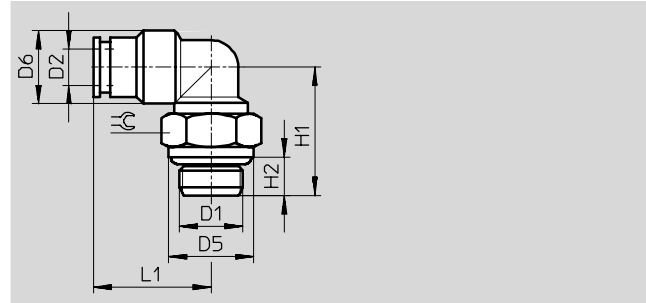

尺寸和订货数据

接口	公称通径	气管外径	D5	D6	H1	H2	L1	≈	重量/件	代号	型号	PU*
D1	[mm]	D2	∅	∅					[g]			
M 螺纹, 带密封圈												
M5	2.2	4	8	9	19.7	4	18.2	8	10.7	533 849	QSL-F-M5-4	○ 新 10
	2.2	6	8	11	19.7	4	20.6	8	14.7	533 850	QSL-F-M5-6	○ 新 10
M7	2.2	4	10.2	9	21.7	5.5	18.2	9	11.3	533 851	QSL-F-M7-4	○ 新 10
	2.2	6	10.2	11	21.7	5.5	20.6	9	15.6	533 852	QSL-F-M7-6	○ 新 10
G 螺纹, 带密封圈												
G ¹ / ₈	3	4	12.8	11	18.2	5.5	17.7	13	17.6	193 418	QSL-F-G ¹ / ₈ -4	10
	3.8	6	12.8	11	18.2	5.5	19.8	13	16	193 419	QSL-F-G ¹ / ₈ -6	10
	3.8	8	12.8	13	20.2	5.5	23	13	20	193 420	QSL-F-G ¹ / ₈ -8	10
G ¹ / ₄	5	6	15.8	11	21	6.5	22.1	16	24.5	193 421	QSL-F-G ¹ / ₄ -6	10
	6	8	15.8	13	21	6.5	23	16	24	193 422	QSL-F-G ¹ / ₄ -8	10
	6	10	15.8	16	23	6.5	26.4	16	34.6	193 423	QSL-F-G ¹ / ₄ -10	10
	6	12	15.8	19	23	6.5	28.9	16	49	533 853	QSL-F-G ¹ / ₄ -12	○ 新 10
G ³ / ₈	6.7	8	20	13	24	7.5	24.5	18	34.2	193 424	QSL-F-G ³ / ₈ -8	10
	8.8	10	20	16	24	7.5	26.4	18	36.6	193 425	QSL-F-G ³ / ₈ -10	10
	8.8	12	20	19	24	7.5	28.9	18	51.1	197 486	QSL-F-G ³ / ₈ -12	10
G ¹ / ₂	9	10	25	17	29	9	27.9	21	66	193 426	QSL-F-G ¹ / ₂ -10	1
	10	12	25	19	29	9	28.9	21	70	193 427	QSL-F-G ¹ / ₂ -12	1

* 包装单元内的数量

■ 核心产品

快插接头 QS-F, 金属型

技术参数

L形快插接头 QSL-F

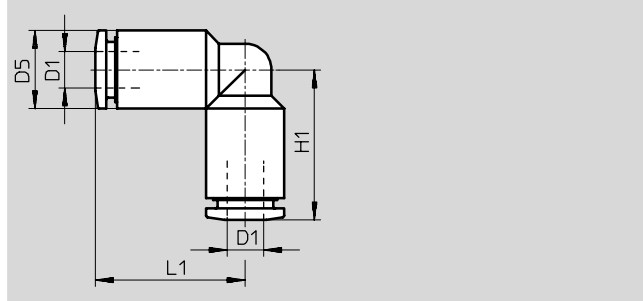

尺寸和订货数据									
气管外径 D1	公称通径 [mm]	D5 ∅	L1	重量/件 [g]	代号	型号			PU*
4	3	9	17.3	9	533 860	QSL-F-4	新		10
6	5	11	20.6	15.1	533 861	QSL-F-6	新		10
6	7	13	23	19.1	533 862	QSL-F-8	新		10
10	9	16	26.4	29.6	533 863	QSL-F-10	新		10
12	10	19	28.9	50.7	533 864	QSL-F-12	新		10

* 包装单元内的数量

穿板式快插接头 QSS-F

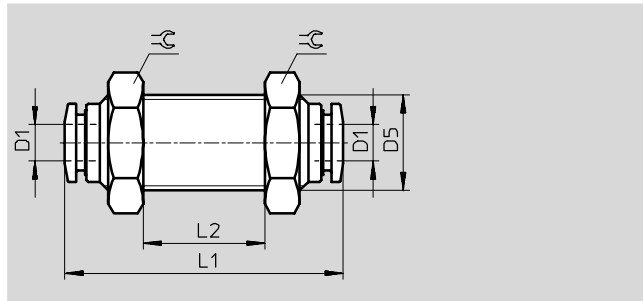
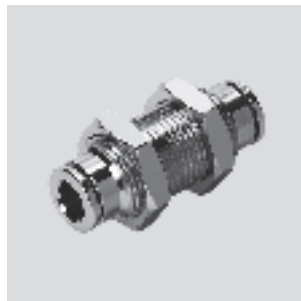

尺寸和订货数据									
气管外径 D1	公称通径 [mm]	D5 ∅	L1	L2	≡	重量/件 [g]	代号	型号	PU*
4	3	M11x1	32	8	14	18.3	533 909	QSS-F-4	新 10
6	5	M14x1	36.1	8	17	29.9	533 910	QSS-F-6	新 10
8	7	M16x1	38	10	18	34.6	533 911	QSS-F-8	新 10
10	9	M18x1	42.3	12	21	50.5	533 912	QSS-F-10	新 10
12	10	M22x1	45.8	17	26	88.2	533 913	QSS-F-12	新 10

* 包装单元内的数量

快插接头 QS-F, 金属型

技术参数

T形快插接头 QST-F

360° 旋转

外螺纹

带外六角

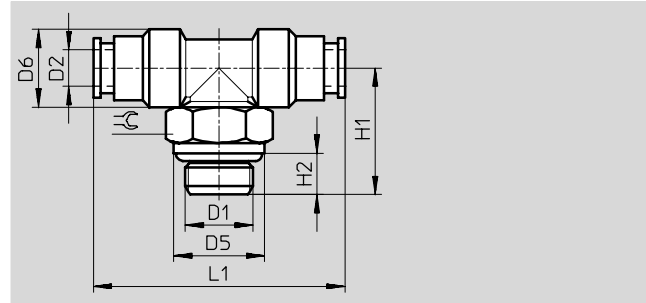

尺寸和订货数据

接口	公称通径	气管外径	D5	D6	H1	H2	L1	≡	重量/件	代号	型号	PU*
D1	[mm]	D2	∅	∅					[g]			
M 螺纹												
M5	2.2	4	8	9	19.7	4	34.6	8	14.6	533 914	QST-F-M5-4	新 10
	2.2	6	8	11	19.7	4	41.2	8	20.9	533 915	QST-F-M5-6	新 10
M7	2.2	4	10.2	9	21.7	5.5	34.6	9	15.9	533 916	QST-F-M7-4	新 10
	2.2	6	10.2	11	21.7	5.5	41.2	9	22.2	533 917	QST-F-M7-6	新 10
G 螺纹, 带密封圈												
G1/8	2.9	4	12.8	11	18.2	5.5	34.6	13	22	193 428	QST-F-G1/8-4	10
	3.8	6	12.8	11	18.2	5.5	39.6	13	22	193 429	QST-F-G1/8-6	10
	3.8	8	12.8	13	20.2	5.5	46	13	28	193 430	QST-F-G1/8-8	10
G1/4	4.9	6	15.8	11	21	6.5	44.2	16	32	193 431	QST-F-G1/4-6	10
	6	8	15.8	13	21	6.5	46	16	33.6	193 432	QST-F-G1/4-8	10
	6	10	15.8	16	23	6.5	52.8	16	47.5	193 433	QST-F-G1/4-10	10
	6	12	15.8	19	23	6.5	57.8	16	64.2	533 918	QST-F-G1/4-12	新 10
G3/8	6.8	8	20	13	24	7.5	49	18	44	193 434	QST-F-G3/8-8	10
	8.8	10	20	16	24	7.5	52.8	18	51	193 435	QST-F-G3/8-10	10
	8.8	12	20	19	24	7.5	57.8	18	68	197 485	QST-F-G3/8-12	10
G1/2	8.8	10	25	17	29	9	55.8	21	84	193 436	QST-F-G1/2-10	1
	9.8	12	25	19	29	9	57.8	21	90	193 437	QST-F-G1/2-12	1

* 包装单元内的数量

核心产品

快插接头 QS-F, 金属型

技术参数

FESTO

T形快插接头 QST-F

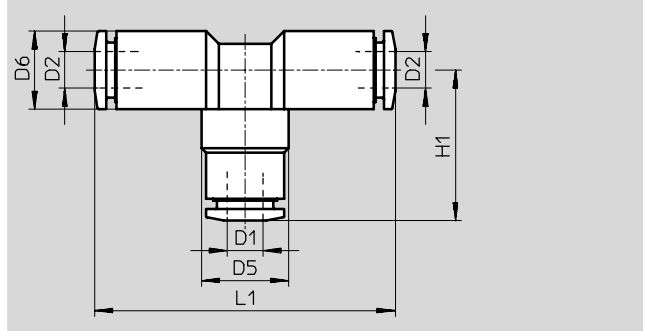

尺寸和订货数据

气管外径 D1	公称通径 [mm]	气管外径 D2	D5 ∅	D6 ∅	H1	L1	重量/件 [g]	代号	型号	PU*
4	3	4	9	9	17.3	34.6	13.1	533 865	QST-F-4	新
6	5	6	11	11	20.6	41.2	21.3	533 866	QST-F-6	新
8	7	8	13	13	23	46	26.9	533 867	QST-F-8	新
10	9	10	16	16	26.4	52.8	43.2	533 868	QST-F-10	新
12	10	12	19	19	28.9	57.8	66.1	533 869	QST-F-12	新
变径										
4	-	6	11	11	20.6	41.2	22.3	533 870	QST-F-6-4	新
6	-	8	11	13	23	46	26.5	533 871	QST-F-8-6	新
8	-	10	13	16	26.4	52.8	41	533 872	QST-F-10-8	新
10	-	12	16	19	28.9	57.8	64.3	533 873	QST-F-12-10	新

* 包装单元内的数量

5.4 硬管、气管和接头 快插接头

5.4

Y形快插接头 QSY-F

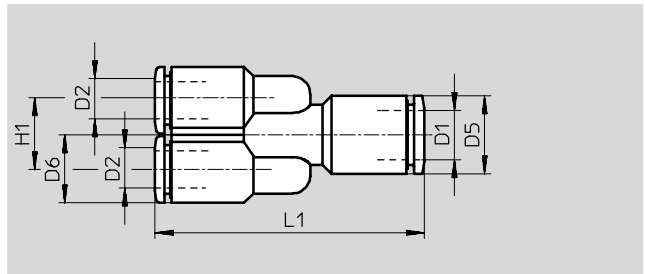

尺寸和订货数据

气管外径 D1	公称通径 [mm]	气管外径 D2	D5 ∅	D6 ∅	H1	L1	重量/件 [g]	代号	型号	PU*
6	5	6	11	11	11.5	43.1	26.2	533 933	QSY-F-6	新
8	7	8	13	13	13.5	46.5	27.6	533 935	QSY-F-8	新
10	9	10	16	16	16.5	49.3	58.8	533 937	QSY-F-10	新
变径										
6	-	4	11	9	9.5	38.8	17.8	533 934	QSY-F-6-4	新
8	-	6	13	11	11.5	44.8	28.1	533 936	QSY-F-8-6	新
10	-	8	16	13	13.5	46.5	39	533 938	QSY-F-10-8	新

* 包装单元内的数量

快插接头 CRQS, 不锈钢型

技术参数

快插接头 CRQS

外螺纹

带内六角

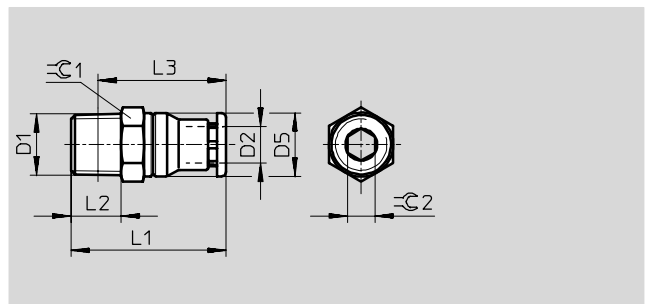
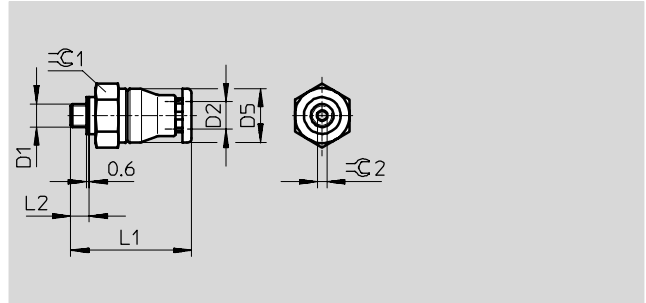

尺寸和订货数据											
接口	公称通径	气管外径	D5 ∅	L1	L2	L3	⊙C1	⊙C2	代号	型号	PU*
D1	[mm]	D2									
公制螺纹, 带密封圈											
M5x0.8	2.4	4	9.8	24.7	4	-	10	2	162 860	CRQS-M5-4	1
	2.4	6	11.8	26.4	4	-	12	2	162 861	CRQS-M5-6	1
R 螺纹											
R1/8	4.6	6	11.8	27.9	8	23.9	12	4	162 862	CRQS-1/8-6	1
	6	8	13.8	30.9	8	26.9	14	5	162 863	CRQS-1/8-8	1
R1/4	7	8	13.8	33.9	11	27.9	14	6	162 864	CRQS-1/4-8	1
	8.5	10	16.8	37.1	11	31.1	17	6	162 865	CRQS-1/4-10	1
R3/8	8.5	10	16.8	38.1	12	31.7	17	6	162 866	CRQS-3/8-10	1
	11	12	19.8	40.1	12	33.7	21	8	162 867	CRQS-3/8-12	1
R1/2	11	12	19.8	43.1	15	34.9	22	8	162 868	CRQS-1/2-12	1
	13	16	23.7	51.1	15	42.9	24	12	162 869	CRQS-1/2-16	1

* 包装单元内的数量

快插接头 CRQS, 不锈钢型

技术参数

FESTO

穿板式快插接头 CRQSS

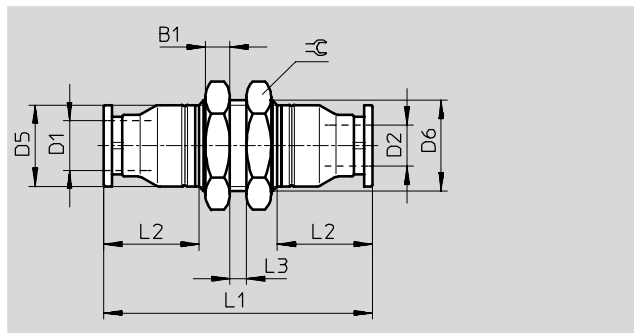

尺寸和订货数据												
气管外径	公称通径	气管外径	D5	D6	B1	L1	L2	L3	⊙	代号	型号	PU*
D1	[mm]	D2	∅	∅								
公制螺纹, 带密封圈												
4	3	4	9.8	M12x1	4	45.4	16.2	4	14	164 210	CRQSS-4	1
6	4.6	6	11.8	M14x1	4	48.8	16.9	6	17	164 211	CRQSS-6	1
8	6	8	13.8	M16x1	4	52.8	18.9	6	19	164 213	CRQSS-8	1
10	8	10	16.8	M20x1	5	59.2	21.1	6	24	164 215	CRQSS-10	1
12	11	12	19.8	M22x1	6	65.2	23.1	6	27	164 217	CRQSS-12	1
16	13	16	23.7	M27x1.5	6	75.2	28.1	5.4	32	164 219	CRQSS-16	1

* 包装单元内的数量

快插接头 CRQS, 不锈钢型

技术参数

FESTO

L形快插接头 CRQSL

360° 旋转

外螺纹

带内六角

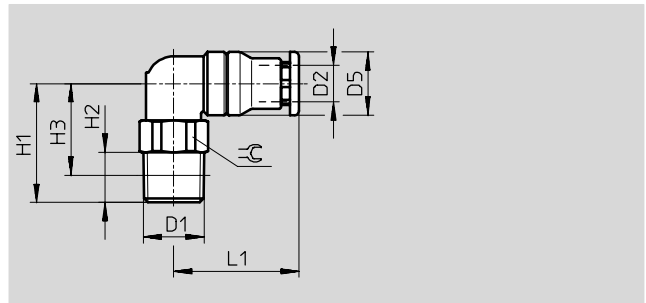
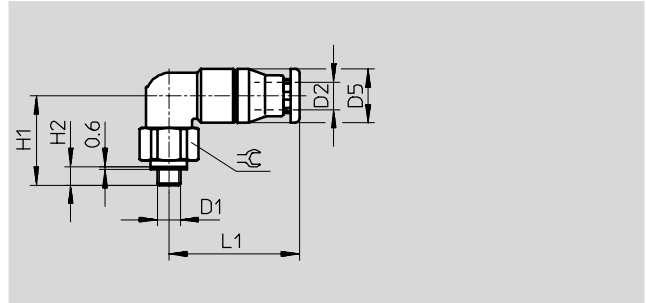

尺寸和订货数据

接口	公称通径	气管外径	D5 ∅	H1	H2	H3	L1	⊕	代号	型号	PU*
D1	[mm]	D2									
公制螺纹, 带密封圈											
M5x0.8	2.4	4	9.8	17.5	4	-	22.7	10	162 870	CRQSL-M5-4	1
	2.4	6	11.8	19.5	4	-	25.4	12	162 871	CRQSL-M5-6	1
R 螺纹											
R1/8	4.6	6	11.8	21	8	17	25.4	12	162 872	CRQSL-1/8-6	1
	6	8	13.8	23	8	19	27.4	14	162 873	CRQSL-1/8-8	1
R1/4	6	8	13.8	26	11	20	27.4	14	162 874	CRQSL-1/4-8	1
	8	10	16.8	29	11	23	31.1	17	162 875	CRQSL-1/4-10	1
R3/8	8	10	16.8	30	12	23.5	31.1	17	162 876	CRQSL-3/8-10	1
	10	12	19.8	34	12	27.5	36.1	21	162 877	CRQSL-3/8-12	1
R1/2	10	12	19.8	37	15	29	36.1	22	162 878	CRQSL-1/2-12	1
	13	16	23.7	38	15	30	45.6	24	162 879	CRQSL-1/2-16	1

* 包装单元内的数量

快插接头 CRQS, 不锈钢型

技术参数

FESTO

T形快插接头 CRQST

360° 旋转

外螺纹

带内六角



M 螺纹

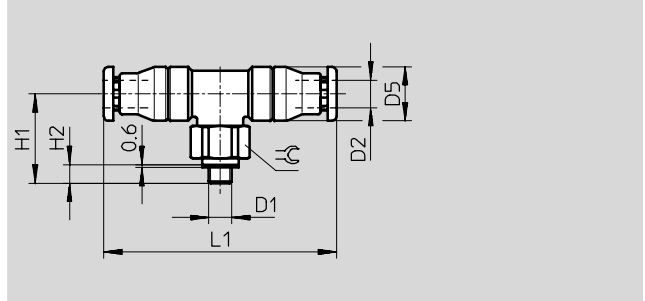

R 螺纹

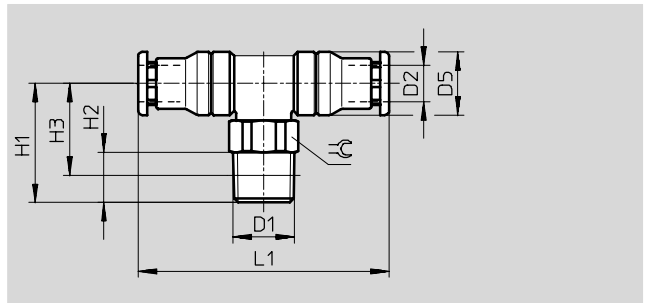

尺寸和订货数据

接口	公称通径	气管外径	D5 -∅	H1	H2	H3	L1	⊕	代号	型号	PU*
D1	[mm]	D2									
公制螺纹, 带密封圈											
M5x0.8	2.4	4	9.8	17.5	4	-	45.4	10	164 200	CRQST-M5-4	1
	2.4	6	11.8	19.5	4	-	50.8	12	164 201	CRQST-M5-6	1
R 螺纹											
R1/8	4.6	6	11.8	21	8	17	50.8	12	164 202	CRQST-1/8-6	1
	6	8	13.8	23	8	19	54.8	14	164 203	CRQST-1/8-8	1
R1/4	6	8	13.8	26	11	20	54.8	14	164 204	CRQST-1/4-8	1
	8	10	16.8	29	11	23	62.2	17	164 205	CRQST-1/4-10	1
R3/8	8	10	16.8	30	12	23.5	62.2	17	164 206	CRQST-3/8-10	1
	10	12	19.8	34	12	27.5	72.2	21	164 207	CRQST-3/8-12	1
R1/2	10	12	19.8	37	15	29	72.2	22	164 208	CRQST-1/2-12	1
	13	16	23.7	38	15	30	91.2	24	164 209	CRQST-1/2-16	1

* 包装单元内的数量

快插接头 QS-V0, 阻燃型

技术参数

FESTO

快插接头 QS-V0

外螺纹

带外六角



R 螺纹

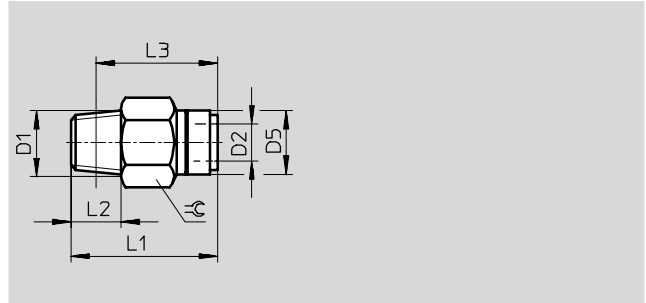

G 螺纹

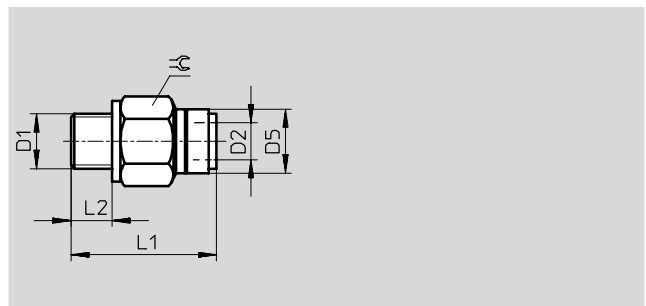

尺寸和订货数据											
接口	公称通径	气管外径	D5 ∅	L1	L2	L3	≈G	重量/件	代号	型号	PU*
D1	[mm]	D2						[g]			
R 螺纹											
R ¹ / ₈	4.6	6	14	28	8	24	12	10	160 500	QS-V0- ¹ / ₈ -6	10
	6	8	16	33.5	8	29.5	14	16.5	160 501	QS-V0- ¹ / ₈ -8	10
R ¹ / ₄	4.6	6	14	30	11	24	14	18	160 502	QS-V0- ¹ / ₄ -6	10
	7	8	16	32	11	26	14	16.5	160 503	QS-V0- ¹ / ₄ -8	10
	8.5	10	19	35.5	11	29.5	17	21.5	160 504	QS-V0- ¹ / ₄ -10	10
R ³ / ₈	11	12	22	41.5	11	35.5	21	44	160 505	QS-V0- ¹ / ₄ -12	10
	7	8	16	29.5	12	23	17	25	160 506	QS-V0- ³ / ₈ -8	10
	8.5	10	19	35	12	28.5	17	27.5	160 507	QS-V0- ³ / ₈ -10	1
R ¹ / ₂	11	12	22	37.5	12	31	21	45	160 508	QS-V0- ³ / ₈ -12	1
	8.5	10	19	36	15	28	21	50.5	160 509	QS-V0- ¹ / ₂ -10	1
R ¹ / ₂	11	12	22	39.5	15	31.5	21	68	160 510	QS-V0- ¹ / ₂ -12	1
	G 螺纹, 带密封圈										
G ¹ / ₈	4.6	6	14	26.1	4.6	-	13	-	186 314	QS-V0-G ¹ / ₈ -6	10
	6	8	16	31.4	4.6	-	14	-	186 315	QS-V0-G ¹ / ₈ -8	10
G ¹ / ₄	4.6	6	14	28.1	6.6	-	17	-	186 316	QS-V0-G ¹ / ₄ -6	10
	7	8	16	28.9	6.6	-	17	-	186 317	QS-V0-G ¹ / ₄ -8	10
	8.5	10	19	35.9	6.6	-	17	-	186 318	QS-V0-G ¹ / ₄ -10	10
G ³ / ₈	11	12	22	41.2	6.6	-	21	-	186 319	QS-V0-G ¹ / ₄ -12	10
	7	8	16	29.1	8.1	-	19	-	186 320	QS-V0-G ³ / ₈ -8	10
	8.5	10	19	32.9	8.1	-	19	-	186 321	QS-V0-G ³ / ₈ -10	10
G ¹ / ₂	11	12	22	39.1	8.1	-	21	-	186 322	QS-V0-G ³ / ₈ -12	10
	8.5	10	19	35.5	11.1	-	24	-	186 323	QS-V0-G ¹ / ₂ -10	1
G ¹ / ₂	11	12	22	37.6	11.1	-	24	-	186 324	QS-V0-G ¹ / ₂ -12	1

* 包装单元内的数量

快插接头 QS-V0, 阻燃型

技术参数

FESTO

快插接头 QS-V0

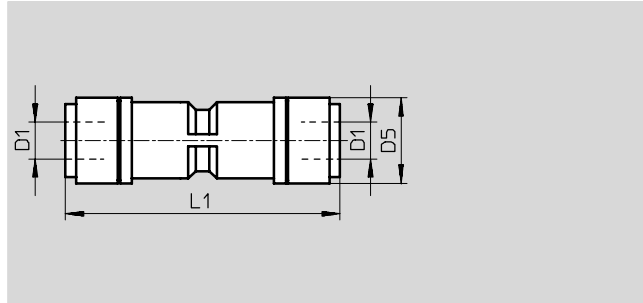

尺寸和订货数据							
气管外径 D1	公称通径 [mm]	D5	L1	重量/件 [g]	代号	型号	PU*
6	5.5	14	45	14	160 546	QS-V0-6	10
8	7	16	48	20	160 547	QS-V0-8	10
10	9	19	54	31	160 548	QS-V0-10	10
12	11	22	58.5	46	160 549	QS-V0-12	10

* 包装单元内的数量

快插接头 QS-V0, 阻燃型

技术参数

FESTO

L形快插接头 QSL-V0

外螺纹

带外六角



R 螺纹

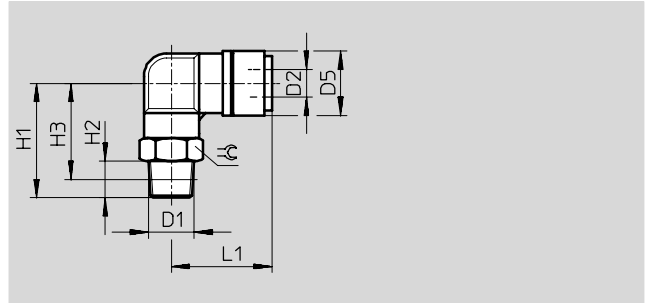

G 螺纹

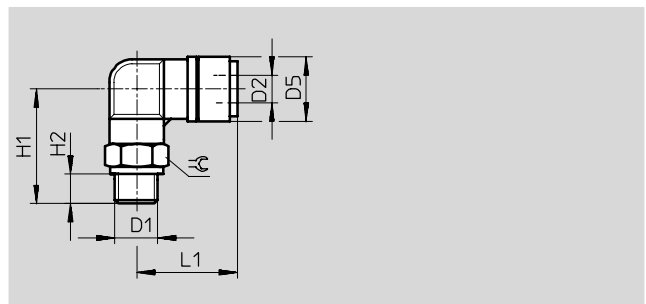

尺寸和订货数据

接口	公称通径	气管外径	D5 ∅	H1	H2	H3	L1	重量/ 件 图	代号	型号	PU*	
D1	[mm]	D2										
R 螺纹												
R ¹ / ₈	4.6	6	14	25	8	20	25	12	15	160 511	QSL-V0- ¹ / ₈ -6	10
	6	8	16	28	8	24	28	14	19.5	160 512	QSL-V0- ¹ / ₈ -8	10
R ¹ / ₄	4.6	6	14	28	11	22	25	14	24	160 513	QSL-V0- ¹ / ₄ -6	10
	6	8	16	31	11	25	28	14	25	160 514	QSL-V0- ¹ / ₄ -8	10
	8	10	19	36	11	30	31.5	17	35	160 515	QSL-V0- ¹ / ₄ -10	10
	10	12	22	38	11	32	34.5	21	52	160 516	QSL-V0- ¹ / ₄ -12	1
R ³ / ₈	6	8	16	33	12	26.5	28	17	37.5	160 517	QSL-V0- ³ / ₈ -8	10
	8	10	19	37	12	30.5	31.5	17	44	160 518	QSL-V0- ³ / ₈ -10	10
	10	12	22	39	12	32.5	34.5	21	53.5	160 519	QSL-V0- ³ / ₈ -12	1
R ¹ / ₂	8	10	19	40	15	32	31.5	21	65	160 520	QSL-V0- ¹ / ₂ -10	1
	10	12	22	42	15	34	34.5	21	76.5	160 521	QSL-V0- ¹ / ₂ -12	1
G 螺纹, 带密封圈												
G ¹ / ₈	4.6	6	14	23.5	4.6	-	24.9	13	-	186 325	QSL-V0-G ¹ / ₈ -6	10
	6	8	16	26.5	4.6	-	27.9	14	-	186 326	QSL-V0-G ¹ / ₈ -8	10
G ¹ / ₄	4.6	6	14	26.5	6.6	-	24.9	17	-	186 327	QSL-V0-G ¹ / ₄ -6	10
	6	8	16	29.5	6.6	-	27.9	17	-	186 328	QSL-V0-G ¹ / ₄ -8	10
	8	10	19	33.5	6.6	-	31.4	17	-	186 329	QSL-V0-G ¹ / ₄ -10	10
	10	12	22.2	35.5	6.6	-	34.7	21	-	186 330	QSL-V0-G ¹ / ₄ -12	1
G ³ / ₈	6	8	16	31.5	8.1	-	27.9	19	-	186 331	QSL-V0-G ³ / ₈ -8	10
	8	10	19	35.5	8.1	-	31.4	19	-	186 332	QSL-V0-G ³ / ₈ -10	10
	10	12	22.2	37.5	8.1	-	34.7	21	-	186 333	QSL-V0-G ³ / ₈ -12	1
G ¹ / ₂	8	10	19	40.5	11.1	-	31.4	24	-	186 334	QSL-V0-G ¹ / ₂ -10	1
	10	12	22.2	42.5	11.1	-	34.7	24	-	186 335	QSL-V0-G ¹ / ₂ -12	1

* 包装单元内的数量

快插接头 QS-V0, 阻燃型

技术参数

FESTO

L形快插接头 QSL-V0

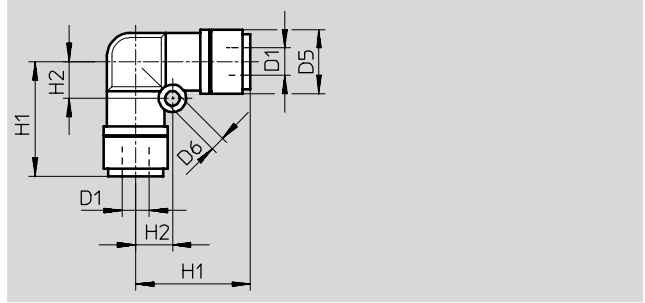

尺寸和订货数据									
气管外径	公称通径	D5	D6	H1	H2	重量/件	代号	型号	PU*
D1	[mm]	∅	∅			[g]			
6	5	14	3.2	25	8	15	160 540	QSL-V0-6	10
8	7	16	4.2	27.5	10	21.5	160 541	QSL-V0-8	10
10	9	19	4.2	31.5	12	32.5	160 542	QSL-V0-10	10
12	11	22	4.2	34.5	14	48	160 543	QSL-V0-12	10

* 包装单元内的数量

快插接头 QS-V0, 阻燃型

技术参数

FESTO

T形快插接头 QST-V0

外螺纹
带外六角



R 螺纹

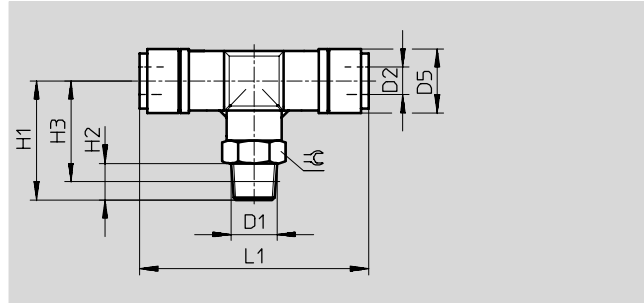

G 螺纹

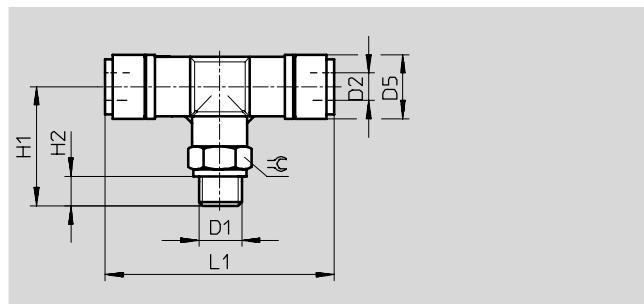

尺寸和订货数据

接口	公称通径	气管外径	D5 ∅	H1	H2	H3	L1	重量/ 件 图	代号	型号	PU*	
D1	[mm]	D2										
R 螺纹												
R ¹ / ₈	4.6	6	14	25	8	20	50	12	19	160 522	QST-V0- ¹ / ₈ -6	10
	6	8	16	28	8	24	55	14	24.5	160 523	QST-V0- ¹ / ₈ -8	10
R ¹ / ₄	4.6	6	14	28	11	22	50	14	28	160 524	QST-V0- ¹ / ₄ -6	10
	6	8	16	31	11	25	55	14	30	160 525	QST-V0- ¹ / ₄ -8	10
	8	10	19	36	11	30	61	17	43	160 526	QST-V0- ¹ / ₄ -10	10
R ³ / ₈	10	12	22	38	11	32	67	21	64	160 527	QST-V0- ¹ / ₄ -12	10
	6	8	16	33	12	26.5	55	17	42.5	160 528	QST-V0- ³ / ₈ -8	10
	8	10	19	37	12	30.5	61	17	52	160 529	QST-V0- ³ / ₈ -10	10
R ¹ / ₂	10	12	22	39	12	32.5	67	21	65.5	160 530	QST-V0- ³ / ₈ -12	1
	8	10	19	40	15	32	61	21	73	160 531	QST-V0- ¹ / ₂ -10	1
	10	12	22	42	15	34	67	21	88.5	160 532	QST-V0- ¹ / ₂ -12	1
G 螺纹, 带密封圈												
G ¹ / ₈	4.6	6	14	24.5	4.6	-	50.6	13	-	186 336	QST-V0-G ¹ / ₈ -6	10
	6	8	16	26.5	4.6	-	55.2	14	-	186 337	QST-V0-G ¹ / ₈ -8	10
G ¹ / ₄	4.6	6	14	27.5	6.6	-	50.6	17	-	186 338	QST-V0-G ¹ / ₄ -6	10
	6	8	16	29.5	6.6	-	55.2	17	-	186 339	QST-V0-G ¹ / ₄ -8	10
	8	10	19	33.5	6.6	-	60.8	17	-	186 340	QST-V0-G ¹ / ₄ -10	10
G ³ / ₈	10	12	22.2	35.5	6.6	-	67.4	21	-	186 341	QST-V0-G ¹ / ₄ -12	10
	6	8	16	31.5	8.1	-	55.2	19	-	186 342	QST-V0-G ³ / ₈ -8	10
	8	10	19	35.5	8.1	-	60.8	19	-	186 343	QST-V0-G ³ / ₈ -10	10
G ¹ / ₂	10	12	22.2	37.5	8.1	-	67.4	21	-	186 344	QST-V0-G ³ / ₈ -12	1
	8	10	19	40.5	11.1	-	60.8	24	-	186 345	QST-V0-G ¹ / ₂ -10	1
	10	12	22.2	42.5	11.1	-	67.4	24	-	186 346	QST-V0-G ¹ / ₂ -12	1

* 包装单元内的数量

硬管、气管和接头
快插接头

5.4

快插接头 QS-V0, 阻燃型

技术参数

FESTO

T形快插接头 QST-V0

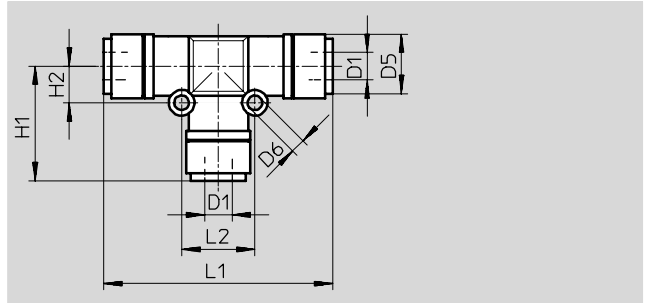

尺寸和订货数据											
气管外径	公称通径	D5	D6	H1	H2	L1	L2	重量/件	代号	型号	PU*
D1	[mm]	∅	∅					[g]			
6	4.6	14	3.2	25	8	50	16	21.5	160 533	QST-V0-6	10
8	6	16	3.2	27.5	9	55	18	31.5	160 534	QST-V0-8	10
10	8	19	4.2	30.5	12	61	24	48	160 535	QST-V0-10	10
12	10	22	4.2	33.5	14	67	28	70.5	160 536	QST-V0-12	1

* 包装单元内的数量

快插接头 QS

附件

FESTO

卸管工具QS0
帮助
QS 快插接头进行卸管









尺寸和订货数据				
气管外径	重量/件 [g]	代号	型号	PU*
3 ... 10	13	158 419	QS0	1

* 包装单元内的数量

倒钩接头

产品范围一览





FESTO

结构特点	型式	型号	接口 D1				接口 D2		→ 页码
			M 螺纹	G 螺纹	倒钩接头	气管内径	倒钩接头	气管内径	
直通结构	倒钩接头, 带外螺纹和外六角								
		N	M5	-	-	-	3.6	3	3 / 5.4-90
							4.8	4	
	倒钩接头, 带外螺纹和外六角								
		CN	M3	-	-	-	2.6; 3.4	2, 3	3 / 5.4-90
			M5	-			2.95; 3.6; 4.8	2, 3, 4	
			-	G1/8			3.6; 4.8; 7	3, 4, 6	
			-	G1/4			4.8; 7	4, 6	
			-	G3/8			7	6	
	穿板式倒钩接头								
		SCN	-	-	2.95	2	-	-	3 / 5.4-91
						3.6	3		
						4.8	4		
						7	6		
	管接头								
	RTU	-	-	2.95	2	2.95	2	3 / 5.4-91	
					2.95	3	2.95		2
					3.6	3	3.6		3
					3.6	3	4.8		4
					4.8	4	4.8		4
					4.8	4	7		6
					7	6	7		6
L形	L形倒钩接头, 带外螺纹 - 360° 旋转								
		LCN	M3	-	-	-	2.95; 3.6	2, 3	3 / 5.4-92
			M5	-			2.95; 3.6; 4.8	2, 3, 4	
			-	G1/8			3.6; 4.8; 7	3, 4, 6	
			-	G1/4			4.8; 7	4, 6	
			-	G3/8			7	6	
	L形倒钩接头, 带外螺纹-延伸气管可360° 旋转								
		LCNH	M5	-	-	-	2.95; 3.6; 4.8	2, 3, 4	3 / 5.4-93
			-	G1/8			3.6; 4.8; 7	3, 4, 6	
			-	G1/4			4.8; 7	4, 6	
			-	G3/8			7	6	
L形倒钩接头									
	L-PK	-	-	2.95	2	-	-	3 / 5.4-93	
					3.6	3			
					4.8	4			
					7	6			

倒钩接头

产品范围一览

FESTO

结构特点	型式	型号	接口 D1				接口 D2		→ 页码
			M 螺纹	G 螺纹	倒钩接头	气管内径	倒钩接头	气管内径	
T形	T形倒钩接头, 带外螺纹 - 360° 旋转								
		TCN	M3		-	-	2.95; 3.6	2, 3	3 / 5.4-94
			M5				2.95; 3.6; 4.8	2, 3, 4	
				G1/8			3.6; 4.8; 7	3, 4, 6	
				G1/4			4.8; 7	4, 6	
				G3/8			7	6	
	T形倒钩接头								
		T-PK	-	-	2.95	2	-	-	3 / 5.4-94
					3.6	3			
					4.8	4			
				7	6				
V形	V形倒钩接头								
		V-PK	-	-	2.95	2	-	-	3 / 5.4-95
					3.6	3			
					4.8	4			
				7	6				
Y形	Y形倒钩接头								
		Y-PK	-	-	2.95	2	-	-	3 / 5.4-95
					3.6	3			
					4.8	4			
				7	6				
	T形倒钩接头								
		FCN	-	-	2.95	2	2.95	2	3 / 5.4-96
					3.6	3	3.6	3	
					3.6	3	2.95	2	
					4.8	4	4.8	4	
					4.8	4	3.6	3	
					7	6	7	6	
				7	6	4.8	4		

倒钩接头 CRCN, 不锈钢型

产品范围一览



FESTO

结构特点	型式	型号	接口 D1				接口 D2		→ 页码
			M 螺纹	G 螺纹	倒钩接头	气管内径	倒钩接头	气管内径	
直通结构		CRCN	M5	-	-	-	2.95; 3.6; 4.8	2, 3, 4	3 / 5.4-97
				G1/8			3.6; 4.8; 7	3, 4, 6	
				G1/4			4.8; 7	4, 6	
				G3/8			7	6	

倒钩接头 C-P/N-P, 用于软管夹

产品范围一览

FESTO

结构特点	型式	型号	接口 D1				接口 D2		→ 页码
			M 螺纹	G 螺纹	倒钩接头	气管内径	倒钩接头	气管内径	
倒钩接头									
	C-...P	-	G 1/8	-	-	7	6	3 / 5.4-98	
			G 1/4			7, 10	6, 9		
			G 3/8			7, 10	6, 9		
			G 1/2			14.8	13		
倒钩接头, 带密封圈 (铝和黄铜结构)									
	N-...P N-...MS	-	G 1/8	-	-	7	6	3 / 5.4-99	
			G 1/4			7, 10	6, 9		
			G 3/8			7, 10, 14.8	6, 9, 13		
			G 1/2			10.3 14.8	9, 13		
			G 3/4			14.8 20.8	13, 19		
管夹, 符合 DIN 3017 标准									
	SK							3 / 5.4-100	

倒钩接头 N/CN

技术参数

FESTO

倒钩接头

N-...PK

带密封圈

材料:

黄铜

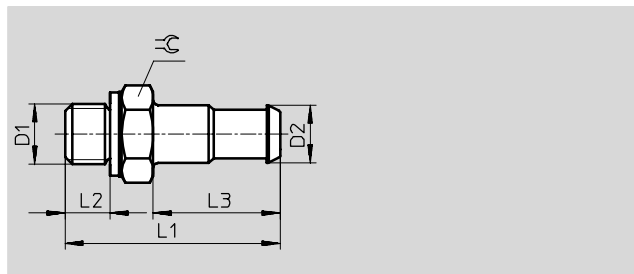

尺寸和订货数据

接口	公称通径	倒钩接头	气管内径	L1	L2	L3	≈	重量	代号	型号	PU*
D1	[mm]	D2						[g]			
M5	2.5	3.6	3	16	3.5	8.5	7	1	4 446	N-M5-PK-3	10
	2.5	4.8	4	18	3.5	10.5	7	2	4 902	N-M5-PK-4	10

* 包装单元内的数量

倒钩接头

CN-...PK

带密封圈

材料:

M3 螺纹: 高合金钢

M5 螺纹: 钢

G 螺纹: 铝

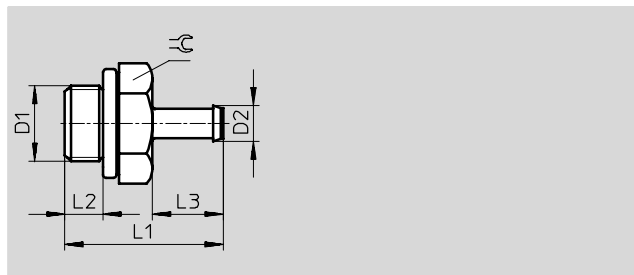

尺寸和订货数据

接口	公称通径	倒钩接头	气管内径	L1	L2	L3	≈	代号	型号	PU*
D1	[mm]	D2								
M 螺纹										
M3	1.5	2.6	2	10	3	5	4.5	15 871	CN-M3-PK-2	10
	1.9	3.4	3	11	3	6	4.5	15 872	CN-M3-PK-3	10
M5	1.5	2.95	2	14	4	6	7	19 521	CN-M5-PK-2	10
	2.5	3.6	3	17.7	4	9.7	7	12 255	CN-M5-PK-3	10
	2.5	4.8	4	19.7	4	11.7	7	12 256	CN-M5-PK-4	10
G 螺纹										
G1/8	2.5	3.6	3	20.2	5	9.7	13	11 944	CN-1/8-PK-3	10
	3.2	4.8	4	22.2	5	11.7	13	11 945	CN-1/8-PK-4	10
	5.3	7	6	24.5	5	14	13	11 946	CN-1/8-PK-6	10
G1/4	3.2	4.8	4	24.7	6	11.7	17	11 947	CN-1/4-PK-4	10
	5.3	7	6	27	6	14	17	11 948	CN-1/4-PK-6	10
G3/8	5.3	7	6	28	7	14	19	11 949	CN-3/8-PK-6	10

* 包装单元内的数量

倒钩接头 N/CN

技术参数

FESTO

穿板式倒钩接头 SCN-PK

材料:
铝

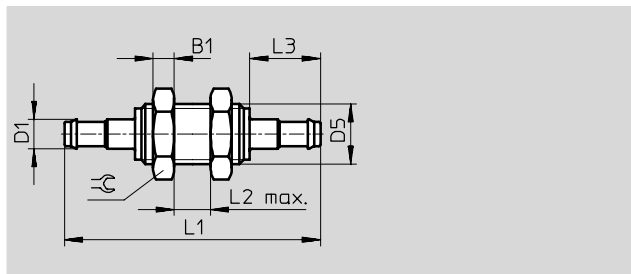

尺寸和订货数据												
倒钩接头	公称通径	气管内径	D5	B1	L1	L2	L3	≡	重量	代号	型号	PU*
D1	[mm]								[g]			
2.95	1.5	2	M4	2.2	23.4	6	6	7	1	19 528	SCN-PK-2	10
3.6	1.9	3	M6x0.75	3.2	35.3	8	9.7	10	4	11 972	SCN-PK-3	10
4.8	2.8	4	M10x1	3.5	42.4	10	11.7	13	7	11 973	SCN-PK-4	10
7	4.8	6	M12x1	4	48	10	14	17	10	11 974	SCN-PK-6	10

* 包装单元内的数量

穿板式倒钩接头 RTU-PK

材料:
黄铜

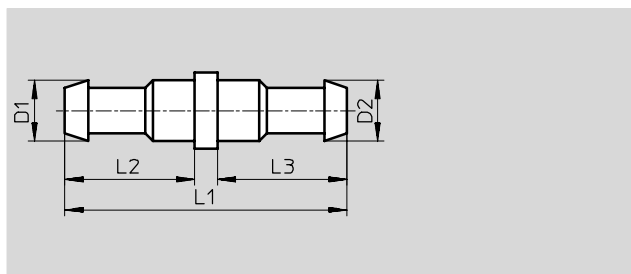

尺寸和订货数据												
倒钩接头		公称通径	气管内径		L1	L2	L3	重量	代号	型号	PU*	
D1	D2	[mm]	D1	D2				[g]				
2.95	2.95	1.5	2	2	14	6	6	1	19 541	RTU-PK-2/2-B	10	
3.6	2.95	1.5	3	2	17.7	9.7	6	1	19 542	RTU-PK-3/2	10	
3.6	3.6	2.5	3	3	19	8.5	8.5	1	4 805	RTU-PK-3/3	10	
3.6	4.8	2.5	3	4	20	8.5	10.5	2	4 499	RTU-PK-3/4	10	
4.8	4.8	3.5	4	4	23	10.5	10.5	2	4 806	RTU-PK-4/4	10	
4.8	7	3.5	4	6	25.5	10.5	13	2	7 604	RTU-PK-4/6	10	
7	7	5.3	6	6	28	13	13	3	7 605	RTU-PK-6/6	10	

* 包装单元内的数量

硬管、气管和接头
快插接头

5.4

倒钩接头 N/CN

技术参数

FESTO

L形倒钩接头 LCN-...-PK

360° 旋转

材料:

M3 螺纹: 高质合金钢, 压铸锌合金

M5 螺纹: 钢, 压铸锌合金

G 螺纹: 铝, 压铸锌合金

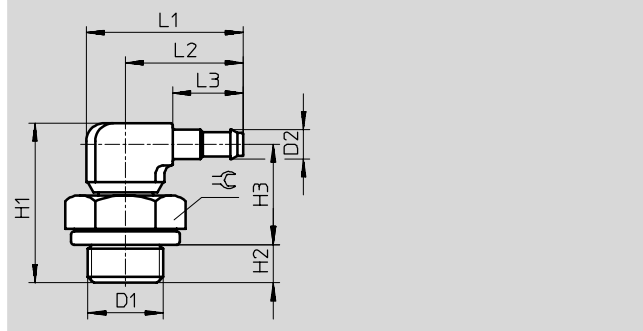

尺寸和订货数据

接口 D1	公称通 径 [mm]	倒钩接 头 D2	气管内径	H1	H2	H3	L1	L2	L3	≈C	重量 [g]	代号	型号	PU*
M 螺纹														
M3	1.3	2.95	2	12.8	2.7	8.1	12.2	9.6	6	4.5	2	30 491	LCN-M3-PK-2-B	10
	2.0	3.6	3	14	2.7	8.7	15.9	13.3	9.7	4.5	2	30 982	LCN-M3-PK-3	10
M5	1.3	2.95	2	15.8	4	9.1	12.2	9.6	6	7	4	19 523	LCN-M5-PK-2	10
	2.0	3.6	3	19.9	4	13.3	18.7	14.7	9.7	7	5	12 257	LCN-M5-PK-3	10
	2.9	4.8	4	21.4	4	13.9	20.7	16.7	11.7	7	6	12 258	LCN-M5-PK-4	10
G 螺纹														
G ¹ / ₈	2.0	3.6	3	21.2	5	13.6	24	17.5	9.7	13	9	11 955	LCN- ¹ / ₈ -PK-3	10
	2.9	4.8	4	22.6	5	14.1	26	19.5	11.7	13	10	11 956	LCN- ¹ / ₈ -PK-4	10
	4.9	7	6	24.6	5	15.1	28.5	22	14.2	13	11	11 957	LCN- ¹ / ₈ -PK-6	10
G ¹ / ₄	2.9	4.8	4	25.1	6	15.6	26	19.5	11.7	17	13	11 958	LCN- ¹ / ₄ -PK-4	10
	4.9	7	6	27	6	16.6	28.5	22	14.2	17	15	11 959	LCN- ¹ / ₄ -PK-6	10
G ³ / ₈	4.9	7	6	28	7	16.6	28.5	22	14.2	19	20	11 960	LCN- ³ / ₈ -PK-6	10

* 包装单元内的数量

倒钩接头 N/CN

技术参数

FESTO

L形倒钩接头 LCNH-...-PK

360° 旋转

材料:

M 螺纹: 钢, 压铸锌合金

G 螺纹: 铝, 压铸锌合金

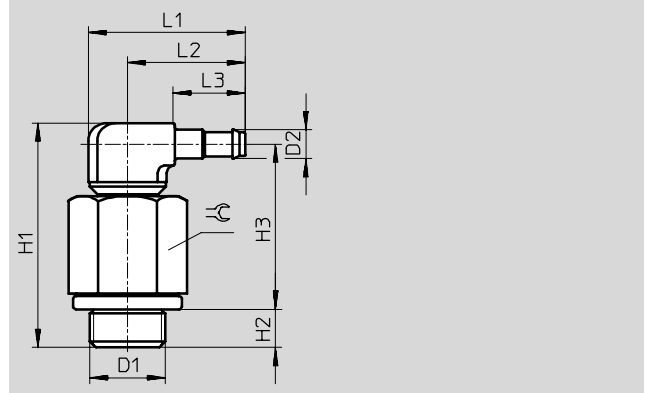

尺寸和订货数据														
接口	公称通径	倒钩接头	气管内径	H1	H2	H3	L1	L2	L3	⌀	重量	代号	型号	PU*
D1	[mm]	D2									[g]			
M 螺纹														
M5	1.3	2.95	2	26.7	4	20.7	12.2	9.6	6	7	8	35 982	LCNH-M5-PK-2	10
	2.0	3.6	3	28.5	4	21.9	18.7	14.7	9.7	7	9	35 983	LCNH-M5-PK-3	10
	2.9	4.8	4	30	4	22.5	20.7	16.7	11.7	7	10	35 984	LCNH-M5-PK-4	10
G 螺纹														
G ¹ / ₈	2.0	3.6	3	31.8	5	24.2	24.0	17.5	9.7	13	13	35 985	LCNH- ¹ / ₈ -PK-3	10
	2.9	4.8	4	33.2	5	24.7	26	19.5	11.7	13	14	35 986	LCNH- ¹ / ₈ -PK-4	10
	4.9	7	6	35.1	5	25.7	28.5	22	14.2	13	16	35 987	LCNH- ¹ / ₈ -PK-6	10
G ¹ / ₄	2.9	4.8	4	35.7	6	26.2	26	19.5	11.7	17	21	35 988	LCNH- ¹ / ₄ -PK-4	10
	4.9	7	6	37.6	6	27.2	28.5	22	14.2	17	22	35 989	LCNH- ¹ / ₄ -PK-6	10
G ³ / ₈	4.9	7	6	38.6	7	27.2	28.5	22	14.2	19	29	35 990	LCNH- ³ / ₈ -PK-6	10

* 包装单元内的数量

L形倒钩接头 L-PK

材料:

黄铜, 塑料



尺寸和订货数据										
倒钩接头	公称通径	气管内径	D5	L1	L2	L3	重量	代号	型号	PU*
D1	[mm]						[g]			
2.95	1.5	2	4	12.2	10.2	6	1	19 539	L-PK-2	10
3.6	2.5	3	6.5	18.9	15.6	9.7	1	7 473	L-PK-3	10
4.8	3.4	4	7.8	22.6	18.7	11.7	2	9 584	L-PK-4	10
7	5.3	6	10.4	31.5	26.3	14	7	150 012	L-PK-6	10

* 包装单元内的数量

倒钩接头 N/CN

技术参数

FESTO

T形倒钩接头 TCN-...-PK

360° 旋转

材料:

M3螺纹: 高质合金钢, 压铸锌合金

M5螺纹: 钢, 压铸锌合金

G螺纹: 铝, 压铸锌合金

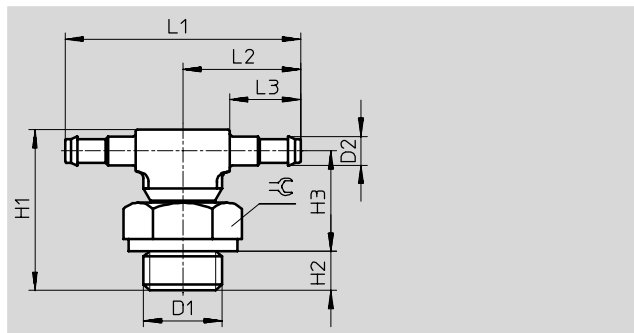

尺寸和订货数据

接口	公称通径	接口	气管内径	H1	H2	H3	L1	L2	L3	≈	代号	型号	PU*
D1	[mm]	D2											
M 螺纹													
M3	1.5	2.95	2	12.8	2.7	8.1	19.2	9.6	6	4.5	30 492	TCN-M3-PK-2	10
	2.0	3.6	3	14	2.7	8.7	26.6	13.3	9.7	4.5	30 983	TCN-M3-PK-3	10
M5	1.3	2.95	2	15.8	4	9.1	19.2	9.6	6	7	19 525	TCN-M5-PK-2	10
	2.0	3.6	3	19.9	4	13.3	29.4	14.7	9.7	7	12 259	TCN-M5-PK-3	10
	2.9	4.8	4	21.4	4	13.9	33.4	16.7	11.7	7	12 432	TCN-M5-PK-4	10
G 螺纹													
G ¹ / ₈	2.0	3.6	3	21.2	5	13.6	35	17.5	9.7	13	11 961	TCN- ¹ / ₈ -PK-3	10
	2.9	4.8	4	22.6	5	14.1	39	19.5	11.7	13	11 962	TCN- ¹ / ₈ -PK-4	10
	4.9	7	6	24.6	5	15.1	44	22	14.2	13	11 963	TCN- ¹ / ₈ -PK-6	10
G ¹ / ₄	2.9	4.8	4	25.1	6	15.6	39	19.5	11.7	17	11 964	TCN- ¹ / ₄ -PK-4	10
	4.9	7	6	27	6	16.6	44	22	14.2	17	11 965	TCN- ¹ / ₄ -PK-6	10
G ³ / ₈	4.9	7	6	28	7	16.6	44	22	14.2	19	11 966	TCN- ³ / ₈ -PK-6	10

* 包装单元内的数量

5.4 硬管、气管和接头 快插接头

T形倒钩接头 T-PK

材料:

黄铜, 塑料

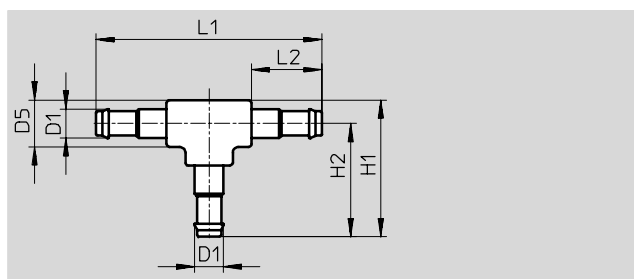

尺寸和订货数据

气管内径	公称通径	气管内径	D5	H1	H2	L1	L2	重量	代号	型号	PU*
D1	[mm]							[g]			
2.95	1.5	2	4	12.2	10.2	20.4	6	1	30 919	T-PK-2	10
3.6	2.5	3	6.5	18.9	15.6	31.2	9.7	2	7 267	T-PK-3	10
4.8	3.4	4	7.8	22.6	18.7	37.4	11.7	3	9 585	T-PK-4	10
7	5.3	6	10.4	31.5	26.3	52.6	14	11	150 015	T-PK-6	10

* 包装单元内的数量

倒钩接头 N/CN

技术参数

FESTO

V形倒钩接头 V-PK

材料:
黄铜, 塑料

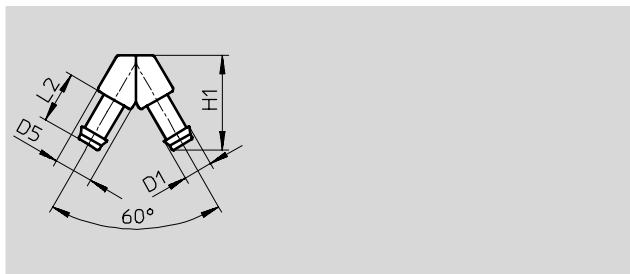

尺寸和订货数据

气管内径 D1	公称通径 [mm]	气管内径	D5	H1	L2	重量 [g]	代号	型号	PU*
2.95	1.5	2	4	11.3	6	1	30 918	V-PK-2	10
3.6	2.5	3	6.5	17.6	9.7	1	7 268	V-PK-3	10
4.8	3.4	4	7.8	21	11.7	2	30 920	V-PK-4	10
7	5.3	6	10.4	29.8	14	8	150 014	V-PK-6	10

* 包装单元内的数量

Y形倒钩接头 Y-PK

材料:
黄铜, 塑料

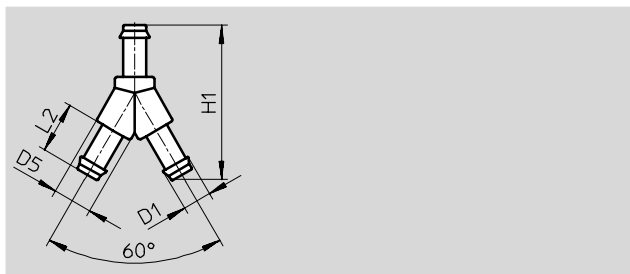

尺寸和订货数据

气管内径 D1	公称通径 [mm]	气管内径	D5	H1	L2	重量 [g]	代号	型号	PU*
2.95	1.5	2	4	18	6	1	19 540	Y-PK-2	10
3.6	2.5	3	6.5	28.8	9.7	2	7 269	Y-PK-3	10
4.8	3.4	4	7.8	34.5	11.7	3	9 586	Y-PK-4	10
7	5.3	6	10.4	49.2	14	12	150 013	Y-PK-6	10

* 包装单元内的数量

倒钩接头 N/CN

技术参数

FESTO

T形倒钩接头 FCN

材料:
压铸锌合金

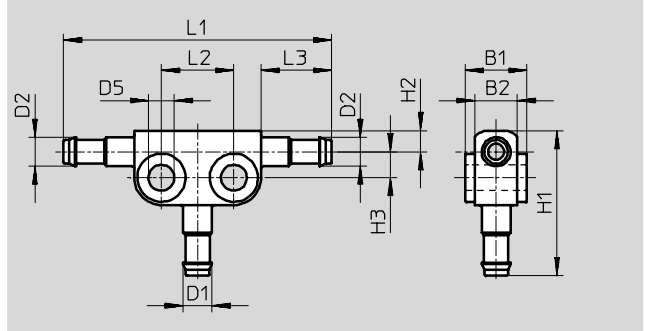

尺寸和订货数据																	
接口		公称通径 [mm]	气管内径		B1	B2	D5	H1	H2	H3	L1	L2	L3	重量 [g]	代号	型号	PU*
D1	D2		D1	D2													
2.95	2.95	1.3	2	2	6	4	3.2	15.7	3.1	2.6	28	8	6	5	19 527	FCN-3-PK-2-B	10
3.6	3.6	2	3	3	8.4	5.2	4.3	21.6	3.5	3.9	38.4	10	9.7	8	14 768	FCN-3-PK-3	10
3.6	2.95	2/1.3	3	2	8.4	5.2	4.3	17.9	3.5	3.9	38.4	10	9.7	8	31 314	FCN-3-PK-3/2	10
4.8	4.8	2.9	4	4	10.2	7	4.3	24	3.5	4.3	44.4	12	11.7	12	14 769	FCN-3-PK-4	10
4.8	3.6	2.9/2	4	3	10.2	7	4.3	22	3.5	4.3	44.4	12	11.7	12	31 315	FCN-3-PK-4/3	10
7	7	4.9	6	6	12	8.8	4.3	28.4	4.4	5.3	49.4	12	14.2	16	14 770	FCN-3-PK-6	10
7	4.8	4.9/2.9	6	4	12	8.8	4.3	25.9	4.4	5.3	49.4	12	14.2	16	31 316	FCN-3-PK-6/4	10

* 包装单元内的数量

倒钩接头 CRCN, 不锈钢型

技术参数

FESTO

倒钩接头 CRCN

带密封圈和外六角

材料:
高质合金钢

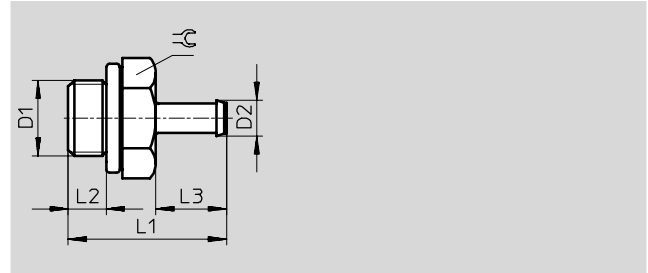

尺寸和订货数据										
接口	公称通径	倒钩接头	气管内径	L1	L2	L3	≈C	代号	型号	PU*
D1	[mm]	D2								
M 螺纹										
M5	1.5	2.95	2	14	4	6	7	30 985	CRCN-M5-PK-2	10
	2.5	3.6	3	17.7	4	9.7	7	13 967	CRCN-M5-PK-3	10
	2.5	4.8	4	19.7	4	11.7	7	13 968	CRCN-M5-PK-4	10
G 螺纹										
G1/8	2.5	3.6	3	20.2	5	9.7	13	13 969	CRCN-1/8-PK-3	10
	3.2	4.8	4	22.2	5	11.7	13	13 970	CRCN-1/8-PK-4	10
	5.3	7	6	24.5	5	14	13	13 971	CRCN-1/8-PK-6	10
G1/4	3.2	4.8	4	24.7	6	11.7	17	13 972	CRCN-1/4-PK-4	1
	5.3	7	6	27	6	14	17	13 973	CRCN-1/4-PK-6	1
G3/8	5.3	7	6	28	7	14	19	13 974	CRCN-3/8-PK-6	1

* 包装单元内的数量

倒钩接头 C-P/N-P, 用于软管夹

技术参数

FESTO

倒钩接头 C-...P
带内螺纹

材料:
黄铜
铝

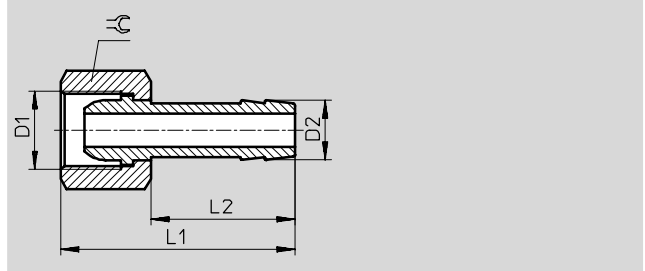

尺寸和订货数据										
接口	公称通径	接口	气管内径	L1	L2	≈G	重量	代号	型号	PU*
D1	[mm]	D2					[g]			
G 螺纹										
G ¹ / ₈	4	7	6	36	24	13	18	2 021	C- ¹ / ₈ -P-6	10
G ¹ / ₄	4.5	7	6	39	24	17	28	2 022	C- ¹ / ₄ -P-6	10
	5.5	10	9	39	24	17	34	2 023	C- ¹ / ₄ -P-9	10
G ³ / ₈	4.5	7	6	39	24	19	31	2 024	C- ³ / ₈ -P-6	1
	6.5	10	9	39	24	19	34	2 025	C- ³ / ₈ -P-9	1
G ¹ / ₂	11	14.8	13	50	30	24	64	2 026	C- ¹ / ₂ -P-13	1

* 包装单元内的数量

倒钩接头 C-P/N-P, 用于软管夹

技术参数

FESTO

倒钩接头 N...-P

带密封圈和外六角

材料:

N...P: 蓝色阳极氧化铝

N...P...MS: 黄铜

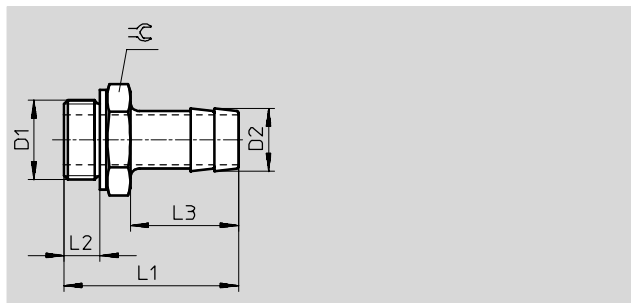

尺寸和订货数据											
接口	公称通径	倒钩接头	气管内径	L1	L2	L3	⌀	重量	代号	型号	PU*
D1	[mm]	D2						[g]			
G 螺纹											
G1/8	4.5	7	6	34.7	5	24.2	13	14	3 605	N-1/8-P-6	10
G1/4	4.5	7	6	37.1	6	24.1	17	21	3 606	N-1/4-P-6	10
	6.5	10	9	37.1	6	24.1	17	24	3 607	N-1/4-P-9	10
G3/8	4.5	7	6	38.1	7	24.1	19	34	3 608	N-3/8-P-6	10
	7.6	10	9	38.1	7	24.1	19	31	3 609	N-3/8-P-9	10
	11	14.8	13	45.4	7	30	19	35	36 160	N-3/8-P-13	1
G1/2	8	10.3	9	39.5	8.5	24	24	61	3 610	N-1/2-P-9	1
	11	14.8	13	45.5	8.5	30	24	63	3 611	N-1/2-P-13	1
G3/4	11	14.8	13	50	10	30	32	113	3 612	N-3/4-P-13	1
	16.5	20.8	19	56	10	36	32	117	3 613	N-3/4-P-19	1
MS 材料											
G1/8	4.5	7	6	34.7	5	24.2	13	10	15 630	N-1/8-P-6-MS	10
G1/4	4.5	7	6	37.1	6	24.1	17	15	15 631	N-1/4-P-6-MS	10
	6.5	10	9	37.1	6	24.1	17	20	15 632	N-1/4-P-9-MS	10
G3/8	4.5	7	6	38.1	7	24.1	19	30	15 633	N-3/8-P-6-MS	10
	7.6	10	9	38.1	7	24.1	19	35	15 634	N-3/8-P-9-MS	10
	11	14.8	13	45.4	7	30	19	40	36 161	N-3/8-P-13-MS	1
G1/2	8	10.3	9	39.5	8.5	24	24	50	15 635	N-1/2-P-9-MS	1
	11	14.8	13	45.5	8.5	30	24	55	15 636	N-1/2-P-13-MS	1
G3/4	11	14.8	13	50	10	30	32	100	15 637	N-3/4-P-13-MS	1
	16.5	20.8	19	56	10	36	32	105	15 638	N-3/4-P-19-MS	1

* 包装单元内的数量

软管夹 SK

技术参数

软管夹 SK

符合 DIN 3017 标准

软管夹具有蜗杆螺纹。带子宽度为 8 mm。

材料：
钢



尺寸和订货数据				
夹紧范围 \varnothing [mm]	重量 [g]	代号	型号	PU*
10 ... 16	7	9 274	SK-10-16	10
16 ... 25	12	9 275	SK-16-25	10
20 ... 32	13	9 276	SK-20-32	10

* 包装单元内的数量

快插接头 CQ, 用于硬管快插系统

主要特征一览

FESTO



硬管、气管和接头
快插接头

5.4

概述

- 适合于聚酰胺制成的硬管 PQ-PA 和铝制硬管 PQ-AL
外径 \varnothing 为 12, 15, 18, 22 和 28 mm
→ 3 / 5.1-1
- 适合于聚酰胺制成的硬管 PAN, PAN-L 和聚氨酯制成的硬管 PUN
外径 \varnothing 为 12 mm
→ 3 / 5.2-1
- 适用于压缩空气、真空或液体
- 硬管/气管由外部固定, 可确保公称规格无缩减。
- 简单、快速安装:
 - 剪至所需长度
 - 插入
 - 即可使用
- 安装、拆卸硬管/气管不需要专用工具
- 快速拆卸接口
- 可重复使用若干次
- 卸管工具 CQO (用于管径为 12 ... 22 的管子) 适用于需经常拆卸或难以接触到快插接头的场合。
- 保持环 CQSR (作为附件) 使管道间保持一定距离。规格为 28 的产品还带有固定装置。
- 柱面的拧入螺纹符合 DIN ISO 228/1 标准, 用带倒角的 O 形圈密封, 规格为 28 的产品带有 PVC 扁平密封。
- 不需要螺纹密封
- 快插接头材料经 FDA (食品及药物管理局) 认证
特例: 快插接头 CQ-1-28-H
- 与钢管和镀锌管相比重量更轻

快插接头 CQ, 用于硬管快插系统

技术参数

FESTO

硬管、气管和接头
快插接头

5.4

工作压力 [bar]	快插接头					水分离器	
	CQ...-12	CQ...-15	CQ...-18	CQ...-22	CQ...-28	CQA-22	CQA-28
室温 [°C]							
-20	-0.95 ... 15				-0.95 ... 10	-0.95 ... 15	-0.95 ... 10
+23	-0.95 ... 15				-0.95 ... 10	-0.95 ... 15	-0.95 ... 10
+70	-0.95 ... 7					-0.95 ... 7	-
介质温度 [°C]							
1 ... 23	10				10	-	-
1 ... 65	10				7	-	-

材料

剖面图

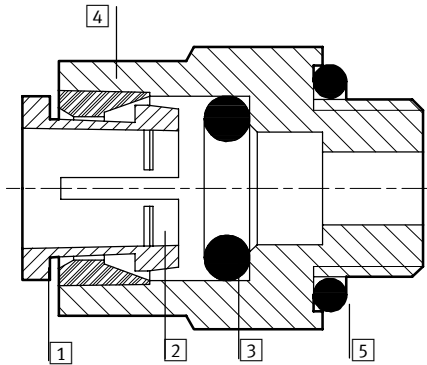









	CQ...	CQ-1-28H
1 卸管压环	聚乙醛	聚乙醛
2 卡片	不锈钢	不锈钢
3 O形圈	丁腈橡胶	丁腈橡胶
4 外壳	聚乙醛	聚乙醛
5 螺纹密封圈	丁腈橡胶	聚氯乙烯

快插接头 CQ, 用于硬管快插系统

产品范围一览





FESTO

结构特点	型式	型号	接口 D1			接口 D2		→ 页码
			G 螺纹	气管/硬管外径	插入套管直径 ∅	气管/硬管外径	插入套管直径 ∅	
直通形结构	快插接头 - 外螺纹							
		CQ	G3/8	-	-	12	-	3 / 5.4-105
			G1/2			12, 15, 18		
			G3/4			22		
	快插接头, 带套管							
		CQ-...H	G3/8	-	-	12, 15	-	3 / 5.4-105
			G1/2			12, 15, 18, 22		
			G3/4			22		
			G1			28		
	快插接头							
	CQ	-	12	-	-	-	3 / 5.4-106	
			15					
			18					
			22					
			28					
快插接头, 带套管								
	CQ-...H	-	12	-	-	15	3 / 5.4-106	
			15			18		
			15			22		
			18			22		
			22			28		
插入式套管								
	CQH-...QS	-	-	15	-	12	3 / 5.4-107	
				18		16		
				22		16		
堵头								
	CQC-...H	-	-	12	-	-	3 / 5.4-107	
				15				
				18				
				22				
				28				
L形	L形快插接头							
		CQL	-	12	-	-	-	3 / 5.4-108
			15					
			18					
			22					
			28					
T形	T形快插接头							
		CQT	-	12	-	-	-	3 / 5.4-108
			15					
			18					
			22					
			28					
		CQT 变径	-	18	-	15	-	3 / 5.4-108
				22		15		

快插接头 CQ, 用于硬管快插系统

产品范围一览

FESTO

结构特点	型式	型号	接口 D1			接口 D2		→ 页码
			G 螺纹	气管/硬管外径	插入套管直径 ∅	气管/硬管外径	插入套管直径 ∅	
直通结构	分气块							
		CQD	-					3 / 5.4-109
	水分离器							
		CQA		22	-	-	-	3 / 5.4-109
				28				
保持环								
	CQSR	-					3 / 5.4-110	
卸管工具								
	CQO	-					3 / 5.4-110	

硬管、气管和接头
快插接头

5.4

快插接头 CQ, 用于硬管快插系统

技术参数

FESTO

快插接头 CQ 带密封圈

材料:
壳体: 聚乙醛

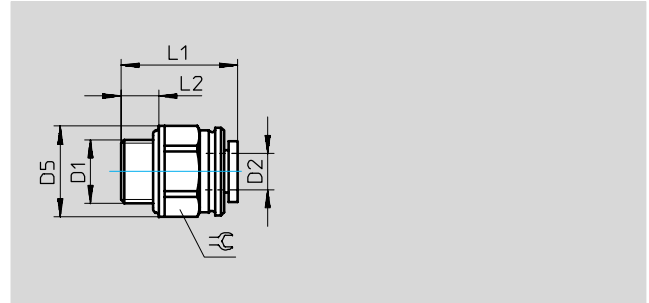

尺寸和订货数据										
接口	公称通径	硬管/气管 外径	D5	L1	L2	≈	重量/件	代号	型号	PU*
D1	[mm]	D2					[g]			
G ³ / ₈	8.6	12	26.4	30.6	9.3	24	8	177 682	CQ- ³ / ₈ -12	1
G ¹ / ₂	8.6	12	29.8	34	12.5	27	12	177 683	CQ- ¹ / ₂ -12	1
	12	15	29.7	38	12.5	27	14	177 684	CQ- ¹ / ₂ -15	1
	12.7	18	34	54.8	12.5	-	24	177 685	CQ- ¹ / ₂ -18	1
G ³ / ₄	22	22	40	60.7	13.4	-	36	177 686	CQ- ³ / ₄ -22	1

* 包装单元内的数量

快插接头 CQ-...H 带插入式套管和密封圈

材料:
壳体: 聚乙醛
(G1 接口: 黄铜)

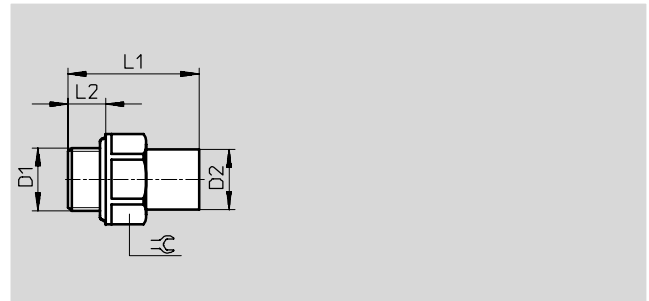

尺寸和订货数据										
接口	公称通径	硬管/气管 外径	L1	L2	≈	重量/件	代号	型号	PU*	
D1	[mm]	D2				[g]				
G ³ / ₈	8.6	12	39.8	9.3	24	4	177 705	CQ- ³ / ₈ -12H	1	
	9.4	15	43.3	12.5	27	10	177 707	CQ- ³ / ₈ -15H	1	
G ¹ / ₂	8.6	12	54.4	11.3	22	8	177 706	CQ- ¹ / ₂ -12H	1	
	10	15	57.9	14.5	27	14	177 708	CQ- ¹ / ₂ -15H	1	
	12.7	18	62.9	14.5	27	18	177 709	CQ- ¹ / ₂ -18H	1	
	12.7	22	64.9	14.5	27	18	177 710	CQ- ¹ / ₂ -22H	1	
G ³ / ₄	17	22	69	17	37	28	177 711	CQ- ³ / ₄ -22H	1	
G1	23	28	80	15	36	200	194 589	CQ-1-28H	1	

* 包装单元内的数量

快插接头 CQ, 用于硬管快插系统

技术参数

FESTO

快插接头 CQ

材料:
聚乙醛

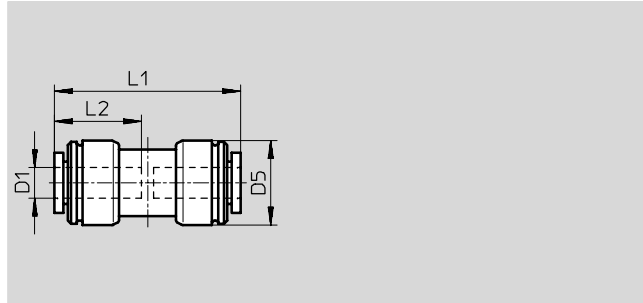

尺寸和订货数据								
硬管/气管 外径 D1	公称通径 [mm]	D5 ∅ ±0.5	L1	L2 ±1	重量/件 [g]	代号	型号	PU*
12	8.6	23	54.4 ±0.5	25	16	177 695	CQ-12	1
15	12	26.8	57.8 ±0.5	27.5	18	177 696	CQ-15	1
18	16	31.1	64.1 ±0.5	30.5	26	177 697	CQ-18	1
22	19.2	35.5	69.6 ±0.5	33	36	177 698	CQ-22	1
28	24.9	49.5	91 ±1	44	90	194 586	CQ-28	1

* 包装单元内的数量

快插接头 CQ...H

带插入套管

材料:
聚乙醛

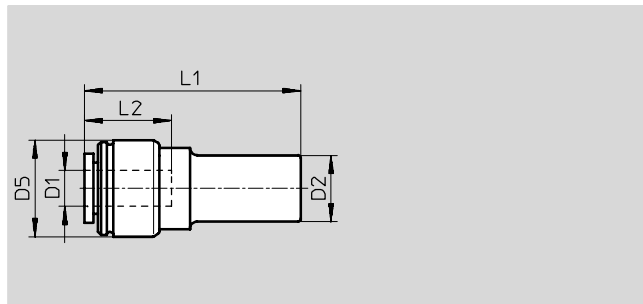

尺寸和订货数据									
硬管/气管 外径 D1	公称通径 [mm]	插入套管直径 ∅ D2	D5 ∅ ±0.5	L1	L2 ±1	重量/件 [g]	代号	型号	PU*
12	9.1	15	27.5	60.2 ±0.5	25	12	177 701	CQ-15H-12	1
15	12.1	18	26.8	70.5 ±0.5	27.5	16	177 702	CQ-18H-15	1
15	12.1	22	26.8	71.5 ±0.5	27.5	16	177 703	CQ-22H-15	1
18	17.3	22	31.1	70.7 ±0.5	30.5	22	177 704	CQ-22H-18	1
22	19.2	28	35.5	81.8 ±1	33	34	196 231	CQ-28H-22	1

* 包装单元内的数量

快插接头 CQ，用于硬管快插系统

技术参数

FESTO

插入式套管 CQH-...-QS
变径接头，用于连接 CQ 到 QS

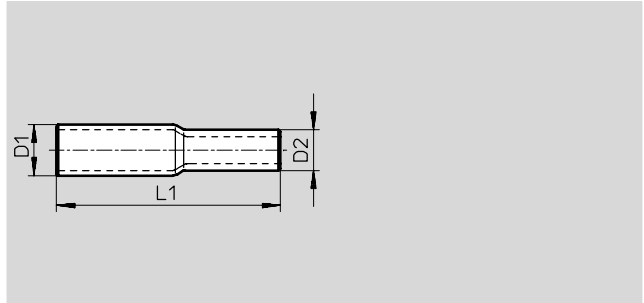

尺寸和订货数据						
插入套管直径 \varnothing D1	插入轴套直径 \varnothing D2	L1	重量/件 [g]	代号	型号	PU*
15	12	66.5	4	177 721	CQH-15-QS-12	1
18	16	71.5	8	177 722	CQH-18-QS-16	1
22	16	80	10	177 723	CQH-22-QS-16	1

* 包装单元内的数量

堵头 CQC-...H

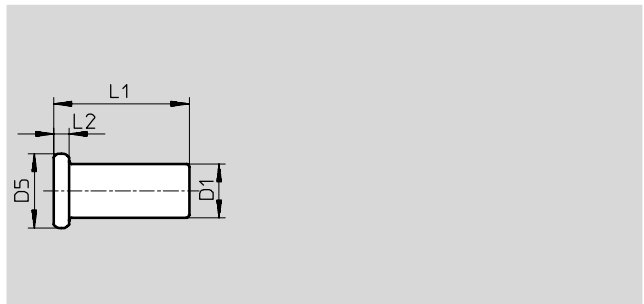

尺寸和订货数据							
插入套管直径 \varnothing D1	D5 \varnothing	L1	L2	重量/件 [g]	代号	型号	PU*
12 ±0.15	21.6	38.8 ±0.5	4.7	4	177 712	CQC-12H	1
15 ±0.15	25	45 ±0.3	5	6	177 713	CQC-15H	1
18 ±0.15	30	41.5 ±0.3	4	8	177 714	CQC-18H	1
22 ±0.15	32	45 ±0.3	4.7	10	177 715	CQC-22H	1
28 -0.1	28	72 ±0.3	5	42	194 590	CQC-28H	1

* 包装单元内的数量

快插接头 CQ, 用于硬管快插系统

技术参数

FESTO

L形快插接头 CQL

材料:
聚乙烯

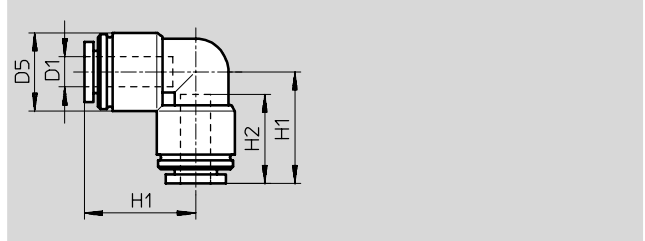

尺寸和订货数据

硬管/气管 外径 D1	公称通径 [mm]	D5 ∅ ±0.5	H1	H2 ±1	重量/件 [g]	代号	型号	PU*
12	8.6	23	32.2±0.5	25	16	177 691	CQL-12	1
15	12	26.8	37.2±0.5	27.5	20	177 692	CQL-15	1
18	16	31.1	44.1±0.5	30.5	32	177 693	CQL-18	1
22	19.2	35.5	48.3±0.5	33	46	177 694	CQL-22	1
28	24.9	49.2	61.4±1	44	106	194 587	CQL-28	1

* 包装单元内的数量

T形快插接头 CQT

材料:
聚乙烯

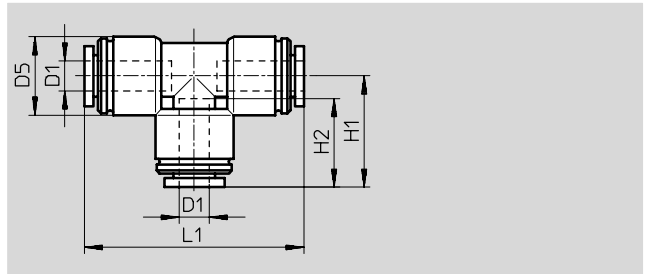

变径

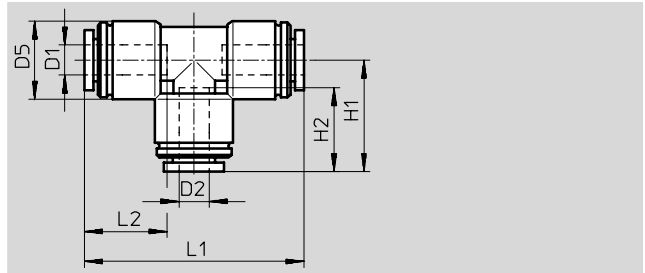

尺寸和订货数据

硬管/气管 外径 D1	公称通径 [mm]	D2 ∅	D5 ∅	H1	H2 ±1	L1	L2	重量/件 [g]	代号	型号	PU*
12	8.6	-	23	32.2±0.5	25	64.4±0.5	-	26	177 687	CQT-12	1
15	12	-	26.8	37.2±0.5	27.5	74.4±0.5	-	30	177 688	CQT-15	1
18	16	-	31.1	44.1±0.5	30.5	88.2±0.5	-	46	177 689	CQT-18	1
22	19.2	-	35.5	48.3±0.5	33	96.6±0.5	-	66	177 690	CQT-22	1
28	24.9	-	49.2	61.4±1	44	121±1	-	152	194 588	CQT-28	1
变径											
18	-	15	31.1	37.9	27.5	84.5	30.5	42	177 699	CQT-18-15	1
22	-	15	35.5	41.6	27.5	89.6	33	56	177 700	CQT-22-15	1

* 包装单元内的数量

快插接头 CQ, 用于硬管快插系统

技术参数

FESTO

分气块 CQD
带 3 个堵头

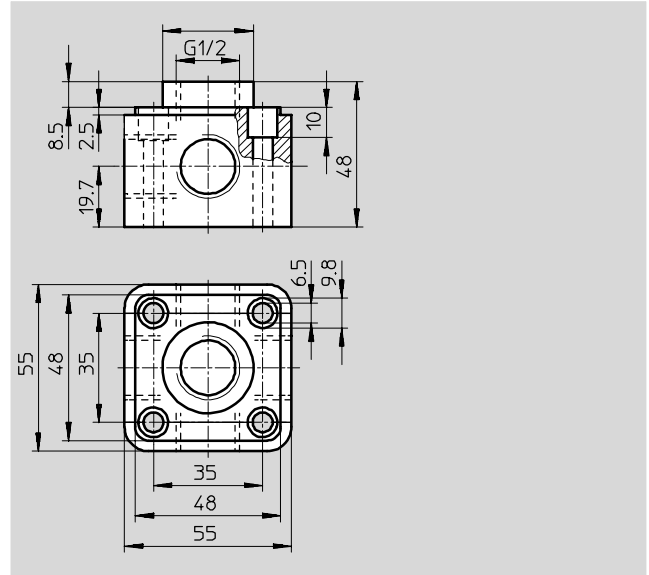

外形尺寸和订货数据			
接口 D1	重量/件 [g]	代号 型号	PU*
G1/2	181	177 717 CQD-12/15/18/22	1

* 包装单元内的数量

水分分离器

用于最大流量至300 l/min的管道。
分水器包括一个水分离装置，防止水进入支路。正确的安装位置如图。
材料：
聚乙醛

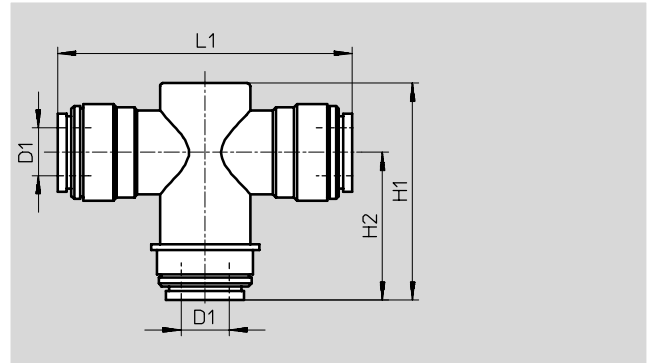

尺寸和订货数据							
硬管/气管 外径 D1	公称通径 [mm]	H1	H2	L1	重量/件 [g]	代号 型号	PU*
22	12	71.8	48.3	97.8	76	177 716 CQA-22	1

* 包装单元内的数量

硬管、气管和接头
快插接头
5.4

快插接头 CQ, 用于硬管快插系统

技术参数

FESTO

水分离器

将液体分离器 CQA-28 插入 T 形快插接头, 形成水分离器。液体分离器是一个带 O 形圈的黄铜插件。将黄铜插件较短的部分插入 PA 或铝制硬管。该装置就卡入 T 形快插接头内了。

材料:
黄铜

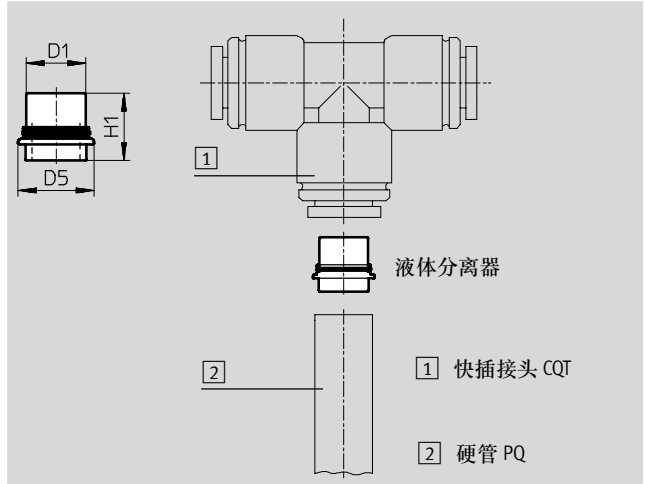

尺寸和订货数据						
硬管/气管外径 D1	D5	H1	重量/件 [g]	代号	型号	PU*
22	28	24.8	18	196 984	CQA-28	1

保持环

保持环使管道间保持一定距离。

材料:
聚乙醛



尺寸和订货数据					
硬管/气管外径 D1	重量/件 [g]	代号	型号	PU*	
12	1	175 727	CQSR-12	1	
15	0.5	175 728	CQSR-15	1	
18	0.5	175 729	CQSR-18	1	
22	0.4	175 730	CQSR-22	1	

卸管工具

材料:
聚乙醛



尺寸和订货数据					
硬管/气管外径 D1	重量/件 [g]	代号	型号	PU*	
15	2	175 725	CQ0-15	1	
22	4	175 726	CQ0-22	1	

* 包装单元内的数量