





- 螺纹连接:
M5, G $\frac{1}{8}$... G $\frac{1}{2}$
- 气管内径:
3 ... 13 mm
- 铝合金或塑料结构
- 带密封圈和成型密封圈

快拧接头 CK/CX

产品范围一览







FESTO

| 结构特点 | 型式 | 型号 | 接口 D1 | | 气管内径 | 不含铜和聚四氟乙烯 | → 页码 |
|---|---|-------------|-------|------------|----------|-----------|-----------|
| | | | M 螺纹 | G 螺纹 | | | |
| 直通结构 | 快拧接头 - 内螺纹, 带密封圈 | | | | | | |
| |  | ACK 金属结构 | - | G1/8 | 3, 4, 6 | ■ | 3 / 5.5-5 |
| | | | | G1/4 | 4, 6 | | |
| | | | | G3/8 | 6, 9 | | |
| | | | | G1/2 | 13 | | |
| | 快拧接头 - 外螺纹, 带密封圈 | | | | | | |
| |  | CK 金属结构 | M5 | - | 3, 4 | ■ | 3 / 5.5-6 |
| | | | - | G1/8 | 3, 4, 6 | | |
| | | | | G1/4 | 4, 6, 9 | | |
| | | | | G3/8 | 6, 9, 13 | | |
| | | | | G1/2 | 13 | | |
| | CK-...KU 塑料结构 | - | G1/8 | 3, 4, 6 | ■ | 3 / 5.5-6 | |
| | | | G1/4 | 4, 6, 9 | | | |
| | | | G3/8 | 6, 9 | | | |
| | 穿板式快拧接头 - 内螺纹, 带密封圈 | | | | | | |
|  | QCK | M5 | - | 3 | ■ | 3 / 5.5-7 | |
| | | - | G1/8 | 4 | | | |
| | | | G1/4 | 6 | | | |
| | | | G3/8 | 9 | | | |
| 穿板式快拧接头 | | | | | | | |
|  | SCK 金属结构 | - | - | 3, 4, 6, 9 | ■ | 3 / 5.5-8 | |
| | SCK-...KU 塑料结构 | - | - | 3, 4, 6, 9 | | | |
| 堵头, 用于塑料气管接头和倒钩接头 | | | | | | | |
|  | CV-PK | - | - | 3, 4, 6, 9 | - | 3 / 5.5-9 | |

快拧接头 CK/CX

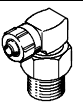
产品范围一览

FESTO

| 结构特点 | 型式 | 型号 | 接口 D1 | | | 气管内径 | 不含铜和聚四氟乙烯 | → 页码 |
|---|---|--------------------|------------|------|---------|------------|------------|------------|
| | | | M 螺纹 | R 螺纹 | G 螺纹 | | | |
| L形 | 直角快拧接头 | | | | | | | |
| |  | GCK-...-KU | - | R1/8 | - | 4, 6 | ■ | 3 / 5.5-10 |
| | | | | R1/4 | | 4, 6 | | |
| | | | | R3/8 | | 6, 9 | | |
| | 直角快拧接头, 可旋转, 带 2 个密封圈 | | | | | | | |
| |  | LCK 金属结构 | M5 | - | - | 3, 4 | ■ | 3 / 5.5-11 |
| | | | - | | G1/8 | 3, 4, 6 | | |
| | | | | | G1/4 | 4, 6, 9 | | |
| | | | | | G3/8 | 6, 9, 13 | | |
| | | | | | G1/2 | 13 | | |
| LCK-...-KU 塑料结构 | - | - | G1/8 | 4, 6 | ■ | 3 / 5.5-11 | | |
| | | | G1/4 | 4, 6 | | | | |
| 直角快拧接头, 带密封圈 (360° 旋转) | | | | | | | | |
|  | LCKN | M5 | - | - | 3, 4 | - | 3 / 5.5-12 | |
| | | - | | G1/8 | 3, 4, 6 | | | |
| | | | | G1/4 | 4, 6 | | | |
| | | | | G3/8 | 6 | | | |
| T形 | T形快拧接头, 可旋转, 带 2 个密封圈 | | | | | | | |
| |  | TCK 金属结构 | M5 | - | - | 3, 4 | ■ | 3 / 5.5-13 |
| | | | - | | G1/8 | 3, 4, 6 | | |
| | | | | | G1/4 | 4, 6 | | |
| | | | | | G3/8 | 6, 9 | | |
| | | | | | G1/2 | 13 | | |
| | TCK-...-KU 塑料结构 | - | - | G1/8 | 4, 6 | ■ | 3 / 5.5-13 | |
| | | | | G1/4 | 4, 6 | | | |
| | T形分气接头 | | | | | | | |
| |  | FCK-...-KU | - | - | - | 3 | ■ | 3 / 5.5-14 |
| | | | | | 4 | | | |
| | | | | | 6 | | | |
| | | | | | 9 | | | |
| 锁紧螺母, 用于 CK 管接头 | | | | | | | | |
|  | MCK 金属结构 | 3, 4, 6, 9, 13 | - | - | - | - | 3 / 5.5-15 | |
| | | MCK-...-KU 塑料结构 | 3, 4, 6, 9 | - | - | - | - | 3 / 5.5-15 |







硬管、气管和接头
快拧接头

5.5

快拧接头 CK/CX

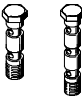
产品范围一览

FESTO

| 结构特点 | 型式 | 型号 | 接口 D1 | | 气管内径 | 不含铜和聚四氟乙烯 | → 页码 |
|---|---|------------|-------|---------|---------|------------|------------|
| | | | M 螺纹 | G 螺纹 | | | |
| 中空复合式分气接头 | 环形管接头, 带 2 个密封 | | | | | | |
| |  | LK 金属结构 | M5 | - | 3, 4 | - | NO TAG |
| | | | - | G1/8 | 3, 4, 6 | | |
| | | | | G1/4 | 4, 6 | | |
| | | | | G3/8 | 6 | | |
| | LK-...-KU 塑料结构 | - | G1/8 | 4, 6 | - | NO TAG | |
| | | - | G1/4 | 4, 6 | | | |
| | 环形管接头, 带 2 个密封 | | | | | | |
| |  | TK 金属结构 | M5 | - | 3, 4 | - | NO TAG |
| | | | - | G1/8 | 3, 4, 6 | | |
| | | | | G1/4 | 4, 6 | | |
| | | | | G3/8 | 6 | | |
| TK-...-KU 塑料结构 | | - | G1/8 | 4, 6 | - | NO TAG | |
| | - | G1/4 | 4, 6 | | | | |
| 中空螺栓, 带 2 个环形管接头 | | | | | | | |
|  | VT-...-2 2 个环形管接头 | M5 | G1/8 | 3, 4, 6 | - | 3 / 5.5-18 | |
| | | | G1/4 | 4, 6 | | | |
| | | | G3/8 | 6 | | | |
| | VT-...-3 3 个环形管接头 | M5 | G1/8 | 3, 4, 6 | - | 3 / 5.5-18 | |
| | | | G1/4 | 4, 6 | | | |
| | | | G3/8 | 6 | | | |
| 用于带金属保护网的气管 PX | | | | | | | |
| 直通结构 | 快拧接头 | | | | | | |
| |  | ACX | - | G1/8 | 4 | - | 3 / 5.5-19 |
| | | | | G1/4 | 6 | | |
| | | | | G3/8 | 9 | | |
| | 快拧接头 | | | | | | |
| |  | CX | - | G1/8 | 4, 6 | - | 3 / 5.5-19 |
| | | | | G1/4 | 4, 6 | | |
| G3/8 | | | | 9 | | | |
| L形 | L形快拧接头 | | | | | | |
| |  | LCX | - | G1/8 | 4 | - | 3 / 5.5-20 |
| | | | | G1/4 | 6 | | |
| | | | | G3/8 | 9 | | |
| T形 | T形快拧接头 | | | | | | |
| |  | TCX | - | G1/8 | 4 | - | 3 / 5.5-20 |
| | | | | G1/4 | 6 | | |
| | | | | G3/8 | 9 | | |

快拧接头 ACK

技术参数

FESTO

快拧接头 ACK

内螺纹，带密封圈

材料:

蓝色阳极氧化铝

不含铜和聚四氟乙烯

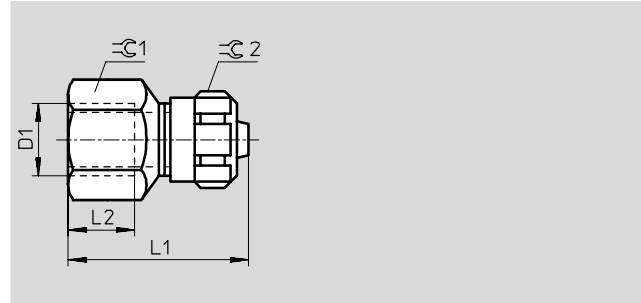

| 尺寸和订货数据 | | | | | | | | | |
|----------|--------------|------|------|----|----|----|-------|---------------|-----|
| 接口 D1 | 公称通径 [mm] | 气管内径 | L1 | L2 | 1 | 2 | 代号 | 型号 | PU* |
| G1/8 | 2.4 | 3 | 23.9 | 9 | 13 | 8 | 5 664 | ACK-1/8-PK-3 | 10 |
| | 3.4 | 4 | 27 | 9 | 13 | 12 | 3 714 | ACK-1/8-PK-4 | 10 |
| | 5.3 | 6 | 27 | 9 | 13 | 14 | 7 842 | ACK-1/8-PK-6 | 10 |
| G1/4 | 3.4 | 4 | 30 | 12 | 17 | 12 | 3 713 | ACK-1/4-PK-4 | 10 |
| | 5.3 | 6 | 30 | 12 | 17 | 14 | 3 712 | ACK-1/4-PK-6 | 10 |
| G3/8 | 5.3 | 6 | 31 | 12 | 19 | 14 | 3 711 | ACK-3/8-PK-6 | 10 |
| | 8 | 9 | 37.4 | 15 | 19 | 19 | 3 710 | ACK-3/8-PK-9 | 1 |
| G1/2 | 12 | 13 | 40.2 | 15 | 27 | 24 | 4 099 | ACK-1/2-PK-13 | 1 |

* 包装单元内的数量

快拧接头 CK

技术参数

FESTO

快拧接头CK

外螺纹，带密封圈

材料：
M 螺纹：钢，铝
G 螺纹：蓝色阳极氧化铝
不含铜和聚四氟乙烯

快拧接头 CK-...KU

外螺纹，带成型密封圈

材料：
塑料
不含铜和聚四氟乙烯

压力范围：0 ... 10 bar
温度范围：-10 ... +60 °C

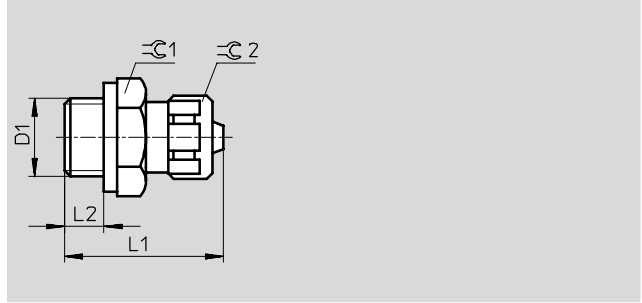

| 尺寸和订货数据 | | | | | | | | | |
|-------------|--------------|------|------|------|----|-----|-------|----------------|-----|
| 接口 D1 | 公称通径 [mm] | 气管内径 | L1 | L2 | ⌀C | ⌀C1 | 代号 | 型号 | PU* |
| 金属结构 | | | | | | | | | |
| M5 | 2.0 | 3 | 19.5 | 4 | 7 | 8 | 3 561 | CK-M5-PK-3 | 10 |
| | 2.9 | 4 | 21.7 | 4 | 10 | - | 3 562 | CK-M5-PK-4 | 10 |
| G1/8 | 2.0 | 3 | 21.6 | 5 | 13 | 8 | 3 563 | CK-1/8-PK-3 | 10 |
| | 2.9 | 4 | 24.7 | 5 | 13 | 12 | 2 027 | CK-1/8-PK-4 | 10 |
| | 4.9 | 6 | 24.8 | 5 | 13 | 14 | 2 028 | CK-1/8-PK-6 | 10 |
| G1/4 | 2.9 | 4 | 27.2 | 6 | 17 | 12 | 2 029 | CK-1/4-PK-4 | 10 |
| | 4.9 | 6 | 27.3 | 6 | 17 | 14 | 2 030 | CK-1/4-PK-6 | 10 |
| | 8 | 9 | 30.6 | 6 | 17 | 19 | 2 031 | CK-1/4-PK-9 | 10 |
| G3/8 | 4.9 | 6 | 28.3 | 7 | 19 | 14 | 2 032 | CK-3/8-PK-6 | 10 |
| | 8 | 9 | 31.6 | 7 | 19 | 19 | 2 033 | CK-3/8-PK-9 | 10 |
| | 11.7 | 13 | 33.2 | 7 | 24 | 24 | 4 097 | CK-3/8-PK-13 | 10 |
| G1/2 | 11.7 | 13 | 34.7 | 8.5 | 24 | 24 | 4 098 | CK-1/2-PK-13 | 1 |
| 塑料结构 | | | | | | | | | |
| G1/8 | 2.4 | 3 | 22.2 | 6.5 | 13 | 8 | 6 253 | CK-1/8-PK-3-KU | 10 |
| | 3.4 | 4 | 25.3 | 6.5 | 13 | 12 | 6 254 | CK-1/8-PK-4-KU | 10 |
| | 4.4 | 6 | 25.4 | 6.5 | 13 | 14 | 6 255 | CK-1/8-PK-6-KU | 10 |
| G1/4 | 3.4 | 4 | 28.5 | 8.5 | 17 | 12 | 6 256 | CK-1/4-PK-4-KU | 10 |
| | 5.3 | 6 | 28.6 | 8.5 | 17 | 14 | 6 257 | CK-1/4-PK-6-KU | 10 |
| | 7.3 | 9 | 31.9 | 8.5 | 17 | 19 | 6 258 | CK-1/4-PK-9-KU | 10 |
| G3/8 | 5.3 | 6 | 31 | 10.5 | 19 | 14 | 6 460 | CK-3/8-PK-6-KU | 10 |
| | 8 | 9 | 34.5 | 10.5 | 19 | 19 | 6 468 | CK-3/8-PK-9-KU | 10 |

* 包装单元内的数量

穿板式快拧接头 QCK

技术参数

FESTO

穿板式快拧接头 QCK

内螺纹，带密封圈

材料:

蓝色阳极氧化铝/钢

不含铜和聚四氟乙烯

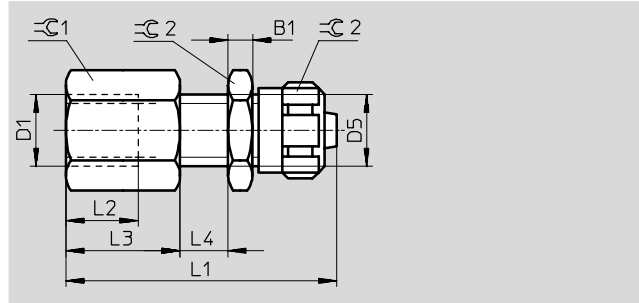

| 尺寸和订货数据 | | | | | | | | | | | | | | | |
|---------|------|------|-----|---------|----|----|------|----|----|-----|-----|-------|----------------|----|-----|
| 接口 | 公称通径 | 气管内径 | B1 | D5 | L1 | L2 | L3 | L4 | 最大 | ⌀C1 | ⌀C2 | ⌀C3 | 代号 | 型号 | PU* |
| D1 | [mm] | | | | | | | | | | | | | | |
| M5 | 2.4 | 3 | 3.2 | M6x0.75 | 31 | 6 | 10 | 8 | 7 | 8 | 10 | 9 424 | QCK-M5-PK-3-B | 1 | |
| G1/8 | 3.4 | 4 | 3.5 | M10x1 | 40 | 8 | 13.5 | 10 | 13 | 12 | 13 | 9 425 | QCK-1/8-PK-4-B | 1 | |
| G1/4 | 5.3 | 6 | 4 | M12x1 | 45 | 12 | 18 | 10 | 17 | 14 | 17 | 9 426 | QCK-1/4-PK-6-B | 1 | |
| G3/8 | 8 | 9 | 5 | M16x1 | 50 | 12 | 18.6 | 10 | 19 | 19 | 22 | 9 427 | QCK-3/8-PK-9-B | 1 | |

* 包装单元内的数量

穿板式快拧接头 SCK

技术参数

FESTO

穿板式快拧接头 SCK

材料:
蓝色阳极氧化铝/钢
不含铜和聚四氟乙烯

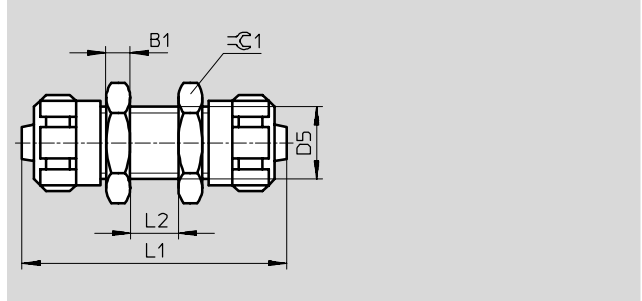

穿板式快拧接头 SCK...-KU

材料:
塑料, 带成型密封圈
不含铜和聚四氟乙烯

压力范围: 0 ... 10 bar
温度范围: -10 ... +60 °C

| 尺寸和订货数据 | | | | | | | | | |
|-------------|------|-----|---------------------|----|----|-----|-------|-------------|-----|
| 公称通径 | 气管内径 | B1 | D5 | L1 | L2 | ±C1 | 代号 | 型号 | PU* |
| [mm] | | | | | 最大 | | | | |
| 铝结构 | | | | | | | | | |
| 2.4 | 3 | 3.2 | M6x0.75 | 34 | 8 | 10 | 9 420 | SCK-PK-3 | 1 |
| 3.4 | 4 | 3.5 | M10x1 | 43 | 10 | 13 | 9 421 | SCK-PK-4 | 1 |
| 5.3 | 6 | 4 | M12x1 | 44 | 10 | 17 | 9 422 | SCK-PK-6 | 1 |
| 8 | 9 | 5 | M16x1 | 53 | 10 | 22 | 9 423 | SCK-PK-9 | 1 |
| 塑料结构 | | | | | | | | | |
| 2.4 | 3 | 5 | M10x1 ¹⁾ | 41 | 10 | 13 | 9 387 | SCK-PK-3-KU | 10 |
| 3.4 | 4 | 5 | M10x1 | 46 | | 13 | 9 388 | SCK-PK-4-KU | 10 |
| 5.3 | 6 | 6 | M12x1 | 48 | | 17 | 9 389 | SCK-PK-6-KU | 10 |
| 8 | 9 | 7 | M16x1 | 57 | | 22 | 9 390 | SCK-PK-9-KU | 1 |

* 包装单元内的数量
1) 安装直径与铝制接头不同

堵头 CV

技术参数

堵头 CV

用于密封倒钩接头和塑料气管接头

材料:
聚氨酯

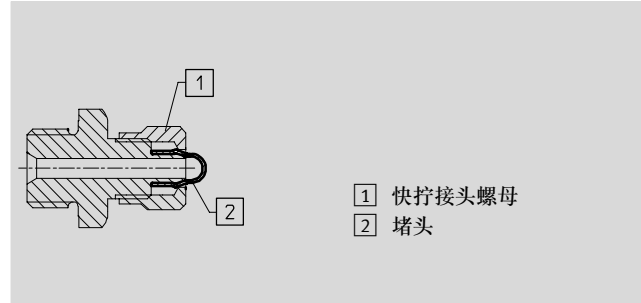

- 1 快拧接头螺母
- 2 堵头

尺寸和订货数据

| 气管内径 | 重量/件 [g] | 代号 | 型号 | PU* |
|------|----------|-------|-----------|-----|
| 3 | 0.001 | 6 213 | CV-PK-3-B | 10 |
| 4 | 0.001 | 6 214 | CV-PK-4-B | 10 |
| 6 | 0.001 | 6 215 | CV-PK-6-B | 10 |
| 9 | 0.002 | 6 216 | CV-PK-9-B | 10 |

工作条件（许用静态压力）

| 型号 | CV-PK-3-B ... CV-PK-6-B | | | | | | CV-PK-9-B | |
|------------|-------------------------|-----|-----|-----|-----|-----|-----------|--|
| 工作压力 [bar] | 10 | 10 | 8 | 7 | 6 | 6 | 4 | |
| 环境温度 [°C] | -35 | +20 | +40 | +60 | +80 | +60 | +80 | |

* 包装单元内的数量

直角快拧接头 GCK

技术参数

FESTO

直角快拧接头 GCK-...-KU

材料:
塑料
不含铜和聚四氟乙烯

压力范围: 0 ... 10 bar
温度范围: -10 ... +60 °C

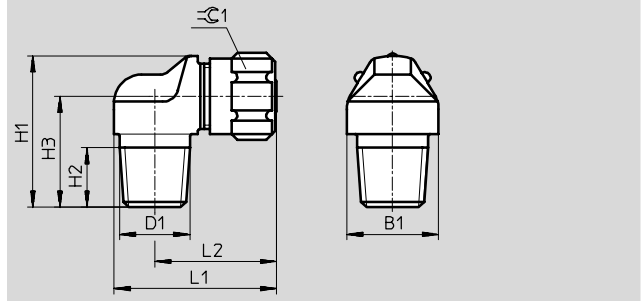

| 尺寸和订货数据 | | | | | | | | | | | | |
|----------|--------------|------|----|------|------|------|------|------|-----------------|-------|-----------------|-----|
| 接口 D1 | 公称通径 [mm] | 气管内径 | B1 | H1 | H2 | H3 | L1 | L2 | \varnothing 1 | 代号 | 型号 | PU* |
| R1/8 | 3 | 4 | 13 | 22.5 | 8 | 16.5 | 26.5 | 20.5 | 20.5 | 6 267 | GCK-1/8-PK-4-KU | 10 |
| | 4.5 | 6 | 17 | 24.5 | 8 | 17.5 | 28.5 | 21.5 | 21.5 | 6 268 | GCK-1/8-PK-6-KU | 10 |
| R1/4 | 3 | 4 | 17 | 25.5 | 11 | 19.5 | 30 | 22.5 | 22.5 | 6 269 | GCK-1/4-PK-4-KU | 10 |
| | 4.5 | 6 | 17 | 27.5 | 11 | 20.5 | 30 | 22.5 | 22.5 | 6 270 | GCK-1/4-PK-6-KU | 10 |
| R3/8 | 4.5 | 6 | 19 | 28.5 | 10.5 | 21 | 34 | 24.5 | 24.5 | 6 271 | GCK-3/8-PK-6-KU | 10 |
| | 7 | 9 | 19 | 33.5 | 10.5 | 23.5 | 37.2 | 27.7 | 27.7 | 6 272 | GCK-3/8-PK-9-KU | 10 |

* 包装单元内的数量

直角快拧接头 LCK

技术参数

FESTO

直角快拧接头 LCK

可旋转，带 2 个密封圈

材料:

压铸锌合金

不含铜和聚四氟乙烯

直角快拧接头

LCK-...KU

可旋转，带成型密封圈

材料:

塑料

不含铜和聚四氟乙烯

压力范围: 0 ... 10 bar

温度范围: -10 ... +60 °C

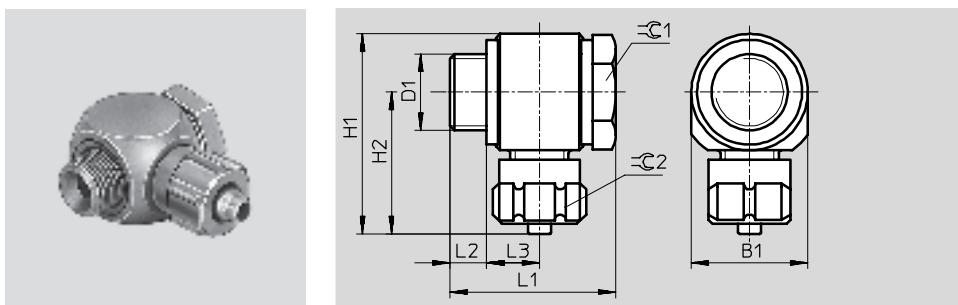

尺寸和订货数据

| 接口 D1 | 公称通径 [mm] | 气管内径 | B1 | H1 | H2 | L1 | L2 | L3 | ⌀1 | ⌀2 | 代号 | 型号 | PU* |
|----------------|--------------|------|----|------|------|------|------|------|----|----|--------|-----------------|-----|
| 压铸锌合金结构 | | | | | | | | | | | | | |
| M5 | 2 | 3 | 10 | 21.1 | 16.1 | 18.2 | 4.2 | 5.7 | 7 | 7 | 4 468 | LCK-M5-PK-3 | 10 |
| | 2.9 | 4 | 11 | 21.1 | 16.1 | 18.2 | 3.4 | 5.7 | 7 | 7 | 4 562 | LCK-M5-PK-4 | 10 |
| G1/8 | 2 | 3 | 16 | 27.1 | 19.1 | 22 | 6.4 | 6 | 13 | 13 | 4 136 | LCK-1/8-PK-3 | 10 |
| | 2.9 | 4 | 16 | 30.2 | 22.2 | 27.5 | 6 | 9 | 13 | 13 | 4 469 | LCK-1/8-PK-4 | 10 |
| | 4.9 | 6 | 16 | 30.3 | 22.3 | 27.5 | 6 | 9 | 13 | 13 | 4 470 | LCK-1/8-PK-6 | 10 |
| G1/4 | 2.9 | 4 | 20 | 34.2 | 24.2 | 28.5 | 7 | 9 | 17 | 17 | 4 471 | LCK-1/4-PK-4 | 10 |
| | 4.9 | 6 | 20 | 34.3 | 24.3 | 28.5 | 6.8 | 9.1 | 17 | 17 | 4 472 | LCK-1/4-PK-6 | 10 |
| | 8 | 9 | 20 | 37.6 | 27.6 | 33.7 | 7.3 | 11.6 | 17 | 17 | 11 452 | LCK-1/4-PK-9 | 10 |
| G3/8 | 4.9 | 6 | 25 | 39.3 | 26.8 | 31 | 8.6 | 9.1 | 22 | 22 | 4 473 | LCK-3/8-PK-6 | 1 |
| | 8 | 9 | 25 | 42.6 | 30.1 | 36.5 | 9.1 | 11.6 | 22 | 22 | 4 474 | LCK-3/8-PK-9 | 1 |
| G1/2 | 11.7 | 13 | 30 | 49.2 | 34.2 | 50 | 12.7 | 16.5 | 27 | 27 | 4 100 | LCK-1/2-PK-13 | 1 |
| 塑料结构 | | | | | | | | | | | | | |
| G1/8 | 3.4 | 4 | 16 | 30.5 | 22.5 | 27.5 | 7.1 | 8.25 | 13 | 13 | 6 259 | LCK-1/8-PK-4-KU | 10 |
| | 5.3 | 6 | 16 | 30.5 | 22.5 | 27.5 | 7.1 | 8.25 | 13 | 13 | 6 260 | LCK-1/8-PK-6-KU | 10 |
| G1/4 | 3.4 | 4 | 20 | 34.5 | 24.5 | 28.5 | 8.1 | 8.25 | 17 | 17 | 6 261 | LCK-1/4-PK-4-KU | 10 |
| | 5.3 | 6 | 20 | 34.5 | 24.5 | 28.5 | 8.1 | 8.25 | 17 | 17 | 6 262 | LCK-1/4-PK-6-KU | 10 |

* 包装单元内的数量

直角快拧接头 LCKN

技术参数

FESTO

直角快拧接头 LCKN

可旋转，带密封圈 OL...

材料:

压铸锌/铝合金，带密封圈

注意: 不能用作旋转式分气接头

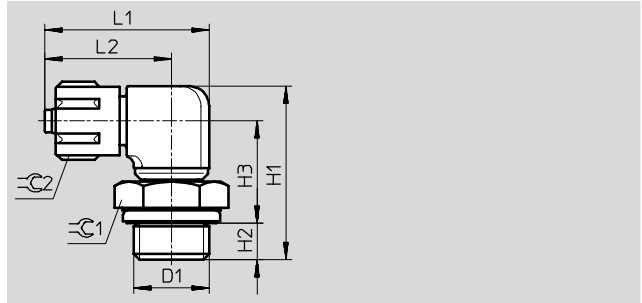

| 尺寸和订货数据 | | | | | | | | | | | | |
|----------|--------------|------|------|------|-------|------|------|-----|-----|---------|---------------|-----|
| 接口 D1 | 公称通径 [mm] | 气管内径 | H1 | H2 | H3 | L1 | L2 | ⌀C1 | ⌀C2 | 代号 | 型号 | PU* |
| M5 | 1.7 | 3 | 22.2 | 3.55 | 15.15 | 20.1 | 16.1 | 7 | 8 | 164 995 | LCKN-M5-PK-3 | 10 |
| | 2.6 | 4 | 24.3 | 3.55 | 15.75 | 23.2 | 19.2 | 7 | - | 164 996 | LCKN-M5-PK-4 | 10 |
| G1/8 | 1.7 | 3 | 24.6 | 4.7 | 15.9 | 25.4 | 18.9 | 13 | 8 | 164 997 | LCKN-1/8-PK-3 | 10 |
| | 2.6 | 4 | 27 | 4.7 | 16.3 | 28.5 | 22 | 13 | 12 | 164 998 | LCKN-1/8-PK-4 | 10 |
| | 4.6 | 6 | 30.3 | 4.7 | 18.6 | 28.6 | 22.1 | 13 | 14 | 164 999 | LCKN-1/8-PK-6 | 10 |
| G1/4 | 2.6 | 4 | 29.5 | 5.8 | 17.7 | 28.5 | 22 | 17 | 12 | 165 000 | LCKN-1/4-PK-4 | 10 |
| | 4.6 | 6 | 32.8 | 5.8 | 20.0 | 28.6 | 22.1 | 17 | 14 | 165 001 | LCKN-1/4-PK-6 | 10 |
| G3/8 | 4.6 | 6 | 33.8 | 6.0 | 20.8 | 28.6 | 22.1 | 19 | 14 | 165 002 | LCKN-3/8-PK-6 | 1 |

* 包装单元内的数量

T 形快拧接头 TCK

技术参数

T 形快拧接头 TCK

可旋转

材料:
 压铸锌合金, 带 2 个密封圈
 螺纹 G $\frac{3}{8}$ 和 G $\frac{1}{2}$ 为蓝色阳极氧化铝
 不含铜和聚四氟乙烯

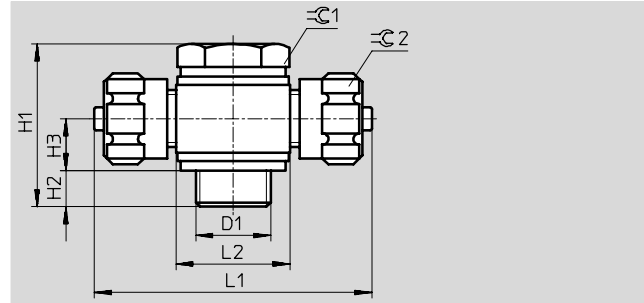

T 形快拧接头

TCK...KU

可旋转

材料:
 塑料, 带成型密封圈
 不含铜和聚四氟乙烯

温度范围: 0 ... 10 bar
 温度范围: -10 ... +60 °C

| 尺寸和订货数据 | | | | | | | | | | | | |
|-----------------|--------------|------|------|------|------|------|----|-----|-----|-------|-----------------------------|-----|
| 接口 D1 | 公称通径 [mm] | 气管内径 | H1 | H2 | H3 | L1 | L2 | ⌀C1 | ⌀C2 | 代号 | 型号 | PU* |
| 压铸锌合金结构 | | | | | | | | | | | | |
| M5 | 2.4 | 3 | 18.2 | 4.2 | 5.7 | 21.1 | 10 | 7 | 8 | 4 484 | TCK-M5-PK-3 | 10 |
| | 3.4 | 4 | 18.2 | 3.4 | 5.7 | 21.1 | 11 | 7 | 8 | 4 563 | TCK-M5-PK-4 | 10 |
| G $\frac{1}{8}$ | 2.4 | 3 | 22 | 6.4 | 6 | 38.2 | 16 | 13 | 8 | 4 137 | TCK- $\frac{1}{8}$ -PK-3 | 10 |
| | 3.4 | 4 | 27.5 | 6 | 9 | 44.4 | 16 | 13 | 12 | 4 485 | TCK- $\frac{1}{8}$ -PK-4 | 10 |
| | 5.3 | 6 | 27.5 | 6 | 9 | 44.6 | 16 | 13 | 14 | 4 486 | TCK- $\frac{1}{8}$ -PK-6 | 10 |
| G $\frac{1}{4}$ | 3.4 | 4 | 28.5 | 7 | 9 | 48.4 | 20 | 17 | 12 | 4 487 | TCK- $\frac{1}{4}$ -PK-4 | 10 |
| | 5.3 | 6 | 28.5 | 6 | 9.1 | 48.6 | 20 | 17 | 14 | 4 488 | TCK- $\frac{1}{4}$ -PK-6 | 10 |
| 铝结构 | | | | | | | | | | | | |
| G $\frac{3}{8}$ | 5.3 | 6 | 31 | 9 | 9 | 53.6 | 25 | 22 | 14 | 4 489 | TCK- $\frac{3}{8}$ -PK-6 | 1 |
| | 8 | 9 | 36.5 | 9.1 | 11.7 | 60.2 | 25 | 22 | 14 | 4 490 | TCK- $\frac{3}{8}$ -PK-9 | 1 |
| G $\frac{1}{2}$ | 12 | 13 | 50 | 12.5 | 16.7 | 68.4 | 30 | 27 | 24 | 4 101 | TCK- $\frac{1}{2}$ -PK-13 | 1 |
| 塑料结构 | | | | | | | | | | | | |
| G $\frac{1}{8}$ | 3.4 | 4 | 27.5 | 7.1 | 8.25 | 45 | 16 | 13 | 12 | 6 263 | TCK- $\frac{1}{8}$ -PK-4-KU | 10 |
| | 5.3 | 6 | 27.5 | 7.1 | 8.25 | 45 | 16 | 13 | 14 | 6 264 | TCK- $\frac{1}{8}$ -PK-6-KU | 10 |
| G $\frac{1}{4}$ | 3.4 | 4 | 28.5 | 8.1 | 8.25 | 49 | 20 | 17 | 12 | 6 265 | TCK- $\frac{1}{4}$ -PK-4-KU | 10 |
| | 5.3 | 6 | 28.5 | 8.1 | 8.25 | 49 | 20 | 17 | 14 | 6 266 | TCK- $\frac{1}{4}$ -PK-6-KU | 10 |

* 包装单元内的数量

T形快拧接头 FCK

技术参数

FESTO

T形分气块FCK-...-KU

材料:
塑料
不含铜和聚四氟乙烯

压力范围: 0 ... 10 bar
温度范围: -10 ... +60 °C

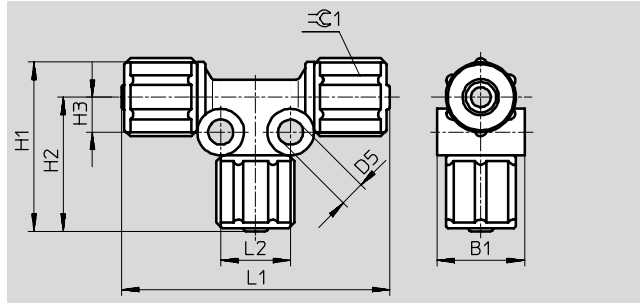

| 尺寸和订货数据 | | | | | | | | | | | | | |
|---------|--------------|----|-----|------|------|-----|------|----|-----------------|-------|---------------|-----|--|
| 气管内径 | 公称通径 [mm] | B1 | D5 | H1 | H2 | H3 | L1 | L2 | $\varnothing 1$ | 代号 | 型号 | PU* | |
| 3 | 2.4 | 11 | 4.3 | 22.9 | 18.9 | 5 | 37.8 | 10 | 8 | 6 273 | FCK-3-PK-3-KU | 10 | |
| 4 | 3.4 | 15 | 4.3 | 29 | 23 | 6 | 46 | 12 | 12 | 6 274 | FCK-3-PK-4-KU | 10 | |
| 6 | 5.3 | 18 | 4.3 | 30.1 | 23.1 | 6 | 46.2 | 12 | 14 | 6 275 | FCK-3-PK-6-KU | 10 | |
| 9 | 8 | 22 | 4.3 | 37 | 28.5 | 7.1 | 53.8 | 13 | 19 | 6 276 | FCK-3-PK-9-KU | 10 | |

* 包装单元内的数量

锁紧螺母 MCK

技术参数

FESTO

锁紧螺母MCK
用于气管接头

材料:
阳极氧化铝

锁紧螺母 MCK-...-KU
用于气管接头

材料:
塑料结构

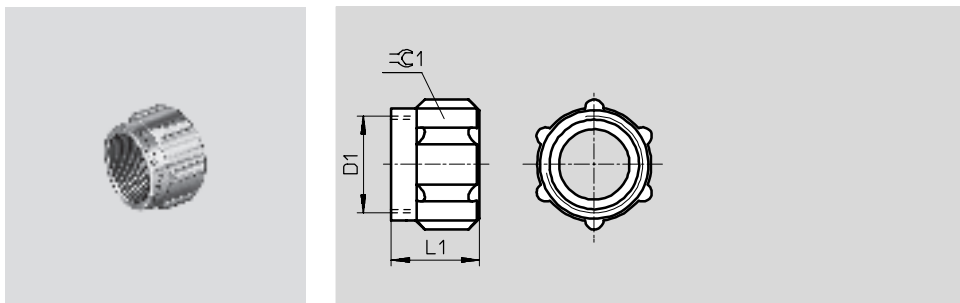

尺寸和订货数据

| 气管内径 | D1 | L1 | ≈C1 | 代号 | 型号 | PU* |
|-------------|---------|------|-----|---------|---------------------------|-----|
| 铝结构 | | | | | | |
| 3 | M6x0.75 | 8.5 | 8 | 205 254 | MCK-PK-3 | 1 |
| 4 | M10x1 | 11 | 12 | 2 965 | MCK-PK-4 ¹⁾ | 1 |
| 4 | M8x1 | 9.5 | - | 205 257 | MCK-PK-4-R ²⁾ | 1 |
| 6 | M12x1 | 11 | 14 | 2 966 | MCK-PK-6 | 1 |
| 9 | M16x1 | 14.4 | 19 | 2 967 | MCK-PK-9 | 1 |
| 13 | M22x1 | 18 | 24 | 206 504 | MCK-PK-13 | 1 |
| 塑料结构 | | | | | | |
| 3 | M6x0.75 | 9.5 | 8 | 211 289 | MCK-PK-3-KU | 1 |
| 4 | M10x1 | 12.5 | 12 | 211 291 | MCK-PK-4-KU ¹⁾ | 1 |
| 6 | M12x1 | 12.5 | 14 | 211 292 | MCK-PK-6-KU | 1 |
| 9 | M16x1 | 16 | 19 | 211 293 | MCK-PK-9-KU | 1 |

* 包装单元内的数量

- 1) 除了接头 CK-M5-PK-4, LCK-M5-PK-4, TCK-M5-PK-4
- 2) 适用于接头 CK-M5-PK-4, LCK-M5-PK-4, TCK-M5-PK-4

中空复合式分气接头

技术参数

FESTO

中空螺栓 VT 带环形管接头 LK
(一个输出接口)

材料:
中空螺栓: 镀锌钢
环形管接头 LK: 压铸锌合金
环形管接头 LK...KU: 塑料

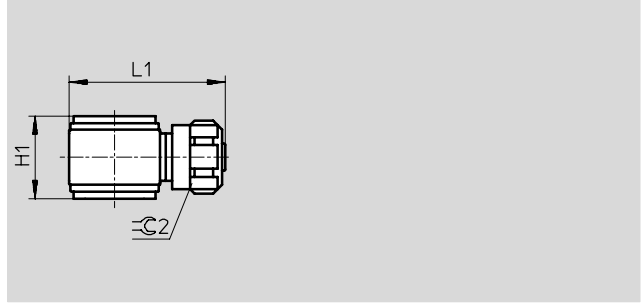

| 订货数据 | | | | 尺寸 → 3 / 5.5-18 | | | |
|----------------|----------|---------|---------------|-----------------|-------|------------------------------|-----|
| 中空螺栓 | | | | 环形管接头 | | | |
| 气接口 | 环形管接头的数量 | 代号 | 型号 | 气接口 | 代号 | 型号 | PU* |
| 压铸锌合金结构 | | | | | | | |
| M5 | 2 | 206 145 | VT-M5-2 | 用于 3 mm 气管 | 4 475 | LK-M5-PK-3 ¹⁾ | 10 |
| | 3 | 4 594 | VT-M5-3 | | | | |
| G1/8 | 2 | 4 593 | VT-1/8-2-PK-3 | 用于 3 mm 气管 | 4 597 | LK-1/8-PK-3 ¹⁾ | 10 |
| | 3 | 4 595 | VT-1/8-3-PK-3 | | | | |
| G1/8 | 2 | 206 146 | VT-1/8-2 | 用于 4 mm 气管 | 4 476 | LK-1/8-PK-4 ¹⁾ | 10 |
| | 3 | 4 596 | VT-1/8-3 | | | | |
| G1/8 | 2 | 206 146 | VT-1/8-2 | 用于 6 mm 气管 | 4 477 | LK-1/8-PK-6 ¹⁾ | 10 |
| | 3 | 4 596 | VT-1/8-3 | | | | |
| G1/4 | 2 | 206 147 | VT-1/4-2 | 用于 4 mm 气管 | 4 478 | LK-1/4-PK-4 ¹⁾ | 10 |
| | 3 | 2 335 | VT-1/4-3 | | | | |
| G1/4 | 2 | 206 147 | VT-1/4-2 | 用于 6 mm 气管 | 4 479 | LK-1/4-PK-6 ¹⁾ | 10 |
| | 3 | 2 335 | VT-1/4-3 | | | | |
| G3/8 | 2 | 206 148 | VT-3/8-2 | 用于 6 mm 气管 | 4 480 | LK-3/8-PK-6 ¹⁾ | 1 |
| | 3 | 2 336 | VT-3/8-3 | | | | |
| 塑料结构 | | | | | | | |
| G1/8 | 2 | 206 146 | VT-1/8-2 | 用于 4 mm 气管 | 6 280 | LK-1/8-PK-4-KU ²⁾ | 10 |
| | 3 | 4 596 | VT-1/8-3 | | | | |
| G1/8 | 2 | 206 146 | VT-1/8-2 | 用于 6 mm 气管 | 6 281 | LK-1/8-PK-6-KU ²⁾ | 10 |
| | 3 | 4 596 | VT-1/8-3 | | | | |
| G1/4 | 2 | 206 147 | VT-1/4-2 | 用于 4 mm 气管 | 6 282 | LK-1/4-PK-4-KU ²⁾ | 10 |
| | 3 | 2 335 | VT-1/4-3 | | | | |
| G1/4 | 2 | 206 147 | VT-1/4-2 | 用于 6 mm 气管 | 6 283 | LK-1/4-PK-6-KU ²⁾ | 10 |
| | 3 | 2 335 | VT-1/4-3 | | | | |

* 包装单元内的数量
1) 带 2 个密封圈
2) 带成型密封圈, 压力范围为 0..10 bar, 温度范围为 -10...+60 °C

中空复合式分气接头

技术参数

中空螺栓 VT 带环形管接头 TK (2 个输出接口)

材料:

中空螺栓: 镀锌钢

环形管接头 TK: 压铸锌合金

环形管接头 TK...KU: 塑料

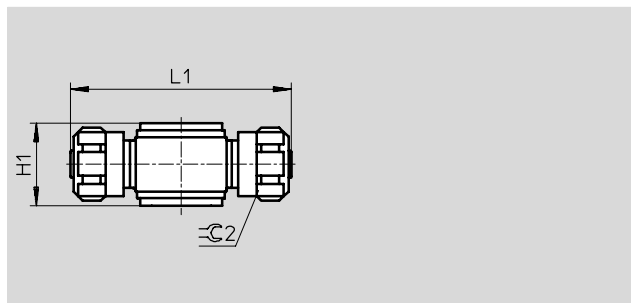

| 订货数据 | | | | 尺寸 → 3 / 5.5-18 | | | |
|----------------|----------|---------|---------------|-----------------|-------|------------------------------|-----|
| 中空螺栓 | | | | 环形管接头 | | | |
| 气接口 | 环形管接头的数量 | 代号 | 型号 | 气接口 | 代号 | 型号 | PU* |
| 压铸锌合金结构 | | | | | | | |
| M5 | 2 | 206 145 | VT-M5-2 | 用于 3 mm 气管 | 4 491 | TK-M5-PK-3 ¹⁾ | 10 |
| | 3 | 4 594 | VT-M5-3 | | 4 598 | TK-1/8-PK-3 ¹⁾ | 10 |
| G1/8 | 2 | 4 593 | VT-1/8-2-PK-3 | 用于 3 mm 气管 | 4 492 | TK-1/8-PK-4 ¹⁾ | 10 |
| | 3 | 4 595 | VT-1/8-3-PK-3 | | 4 493 | TK-1/8-PK-6 ¹⁾ | 10 |
| | 2 | 206 146 | VT-1/8-2 | 用于 4 mm 气管 | 4 494 | TK-1/4-PK-4 ¹⁾ | 10 |
| | 3 | 4 596 | VT-1/8-3 | | 4 495 | TK-1/4-PK-6 ¹⁾ | 10 |
| | 2 | 206 146 | VT-1/8-2 | 用于 6 mm 气管 | 4 496 | TK-3/8-PK-6 ¹⁾ | 1 |
| | 3 | 4 596 | VT-1/8-3 | | | | |
| G1/4 | 2 | 206 147 | VT-1/4-2 | 用于 4 mm 气管 | 6 284 | TK-1/8-PK-4-KU ²⁾ | 10 |
| | 3 | 2 335 | VT-1/4-3 | | 6 285 | TK-1/8-PK-6-KU ²⁾ | 10 |
| | 2 | 206 147 | VT-1/4-2 | 用于 6 mm 气管 | 6 286 | TK-1/4-PK-4-KU ²⁾ | 10 |
| | 3 | 2 335 | VT-1/4-3 | | 6 287 | TK-1/4-PK-6-KU ²⁾ | 10 |
| G3/8 | 2 | 206 148 | VT-3/8-2 | | | | |
| 塑料结构 | | | | | | | |
| G1/8 | 2 | 206 146 | VT-1/8-2 | 用于 4 mm 气管 | 6 284 | TK-1/8-PK-4-KU ²⁾ | 10 |
| | 3 | 4 596 | VT-1/8-3 | | 6 285 | TK-1/8-PK-6-KU ²⁾ | 10 |
| | 2 | 206 146 | VT-1/8-2 | 用于 6 mm 气管 | 6 286 | TK-1/4-PK-4-KU ²⁾ | 10 |
| | 3 | 4 596 | VT-1/8-3 | | 6 287 | TK-1/4-PK-6-KU ²⁾ | 10 |
| G1/4 | 2 | 206 147 | VT-1/4-2 | 用于 4 mm 气管 | 6 286 | TK-1/4-PK-4-KU ²⁾ | 10 |
| | 3 | 2 335 | VT-1/4-3 | | 6 287 | TK-1/4-PK-6-KU ²⁾ | 10 |
| | 2 | 206 147 | VT-1/4-2 | 用于 6 mm 气管 | | | |
| | 3 | 2 335 | VT-1/4-3 | | | | |

* 包装单元内的数量

1) 带 2 个密封圈

2) 带成型密封圈, 压力范围为 0...10 bar, 温度范围为 -10...+60 °C

中空复合式分气接头

技术参数

FESTO

中空复合式分气接头

包括:

■ 中空螺栓 VT 和环形密封圈 LK

→ 3 / 5.5-16

或

■ 中空螺栓 VT 和环形密封圈 TK

→ 3 / 5.5-17

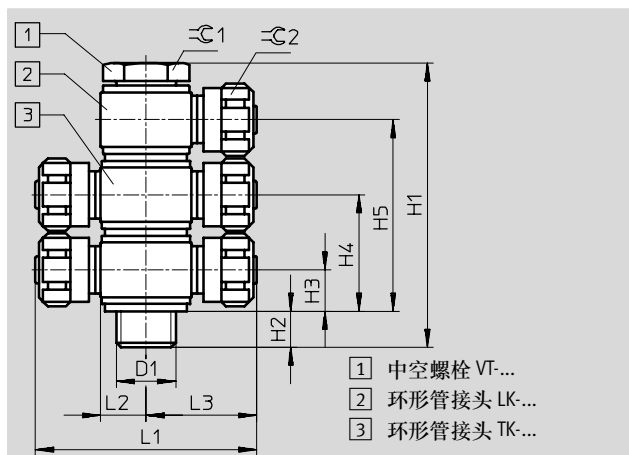

| 尺寸 | | | | | | | | | | | | | | | | |
|-----------------|---------------------------|-------------------------|------|-------------------------|-------------------------|------|------|------|-------------------------|-------------------------|--------------|--------------|------|------|----|----|
| 接口 D1 | 中空螺栓 型号 | 环形密封圈 型号 | H1 | H2 | H3 | H4 | H5 | L1 | L2 | L3 | $\approx C1$ | $\approx C2$ | | | | |
| M5 | VT-M5-2 | LK-M5-PK-3 | 30 | 5.9 | 5.7 | 16.1 | - | - | 5 | 16.1 | 7 | 8 | | | | |
| | | TK-M5-PK-3 | | | | | | | 32.2 | | | | | | | |
| | VT-M5-3 | LK-M5-PK-3 | 40 | 6.1 | 5.7 | 16.1 | 26.5 | - | 5 | 16.1 | 7 | 8 | | | | |
| | | TK-M5-PK-3 | | | | | | | 32.2 | | | | | | | |
| G $\frac{1}{8}$ | VT- $\frac{1}{8}$ -2-PK-3 | LK- $\frac{1}{8}$ -PK-3 | 32.5 | 6.9 | 6 | 16.5 | - | - | 8 | 19.1 | 13 | 8 | | | | |
| | | TK- $\frac{1}{8}$ -PK-3 | | | | | | | 38.2 | | | | | | | |
| | VT- $\frac{1}{8}$ -3-PK-3 | LK- $\frac{1}{8}$ -PK-3 | 43 | 7.3 | 6 | 16.5 | 27 | - | - | 8 | 19.1 | 13 | 8 | | | |
| | | TK- $\frac{1}{8}$ -PK-3 | | | | | | | | 38.2 | | | | | | |
| | VT- $\frac{1}{8}$ -2 | LK- $\frac{1}{8}$ -PK-4 | 44 | 6.5 | 9 | 25.5 | - | - | 8 | 22.2 | 13 | 12 | | | | |
| | | | | | | | | | | TK- $\frac{1}{8}$ -PK-4 | | | 44.4 | | | |
| | | LK- $\frac{1}{8}$ -PK-6 | | | | | | | 22.3 | 14 | | | | | | |
| | | | | | | | | | TK- $\frac{1}{8}$ -PK-6 | | | | 44.6 | | | |
| | VT- $\frac{1}{8}$ -3 | LK- $\frac{1}{8}$ -PK-4 | 60.5 | 6.5 | 9 | 25.5 | 42 | - | 8 | 22.2 | 13 | 12 | | | | |
| | | | | | | | | | | TK- $\frac{1}{8}$ -PK-4 | | | 44.4 | | | |
| | | LK- $\frac{1}{8}$ -PK-6 | | | | | | | 22.3 | 14 | | | | | | |
| | | | | | | | | | TK- $\frac{1}{8}$ -PK-6 | | | | 44.6 | | | |
| G $\frac{1}{4}$ | VT- $\frac{1}{4}$ -2 | LK- $\frac{1}{4}$ -PK-4 | 45 | 8 | 9 | 25 | - | - | 10 | 24.2 | 17 | 12 | | | | |
| | | TK- $\frac{1}{4}$ -PK-4 | | | | | | | 48.4 | | | | | | | |
| | | LK- $\frac{1}{4}$ -PK-6 | | 7.6 | 9.1 | 25.3 | | 10 | 24.3 | | | | 14 | | | |
| | | | | TK- $\frac{1}{4}$ -PK-6 | 48.6 | | | | | | | | | | | |
| | VT- $\frac{1}{4}$ -3 | LK- $\frac{1}{4}$ -PK-4 | 62.5 | 8.8 | 9 | 25 | 41 | - | 10 | 24.2 | 17 | 12 | | | | |
| | | | | | | | | | TK- $\frac{1}{4}$ -PK-4 | | | | 48.4 | | | |
| | | LK- $\frac{1}{4}$ -PK-6 | | 8.2 | 9.1 | 25.3 | | 41.5 | 10 | | | | 24.3 | 14 | | |
| | | | | TK- $\frac{1}{4}$ -PK-6 | 48.6 | | | | | | | | | | | |
| G $\frac{3}{8}$ | VT- $\frac{3}{8}$ -2 | LK- $\frac{3}{8}$ -PK-6 | 48 | 9.6 | 9.1 | 25.3 | 41.5 | - | 12.5 | 26.8 | 22 | 14 | | | | |
| | | TK- $\frac{3}{8}$ -PK-6 | | 10.4 | 9 | 25 | 41 | | 53.6 | | | | | | | |
| | VT- $\frac{3}{8}$ -3 | LK- $\frac{3}{8}$ -PK-6 | | 65 | 9.6 | 9.1 | 25.3 | 41.5 | - | | | | 12.5 | 26.8 | 22 | 14 |
| | | | | | TK- $\frac{3}{8}$ -PK-6 | 10.4 | 9 | 25 | | | | | 41 | | | |

快拧接头 ACX/CX，用于带金属保护网的气管

技术参数

快拧接头 ACX

内螺纹，带密封圈，用于带金属保护网的气管 PX

材料：
阳极氧化铝

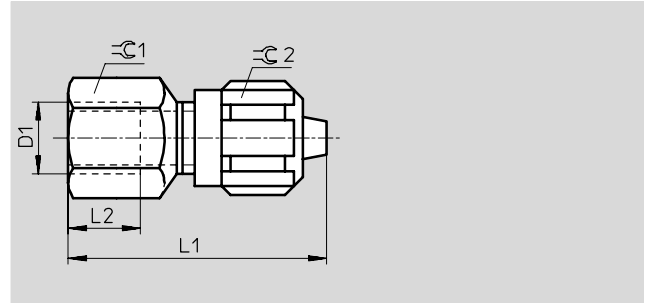

| 尺寸和订货数据 | | | | | | | | | |
|---------|-----------|------|----|----|-----|-----|-------|--------------|-----|
| 接口 D1 | 公称通径 [mm] | 气管内径 | L1 | L2 | ⌀C1 | ⌀C2 | 代号 | 型号 | PU* |
| G1/8 | 3.5 | 4 | 35 | 10 | 13 | 12 | 4 032 | ACX-1/8-PX-4 | 1 |
| G1/4 | 5 | 6 | 43 | 12 | 17 | 14 | 4 033 | ACX-1/4-PX-6 | 1 |
| G3/8 | 8 | 9 | 54 | 15 | 22 | 19 | 4 034 | ACX-3/8-PX-9 | 1 |

* 包装单元内的数量

快拧接头 CX

外螺纹，带密封圈，用于带金属保护网的气管 PX

材料：
阳极氧化铝

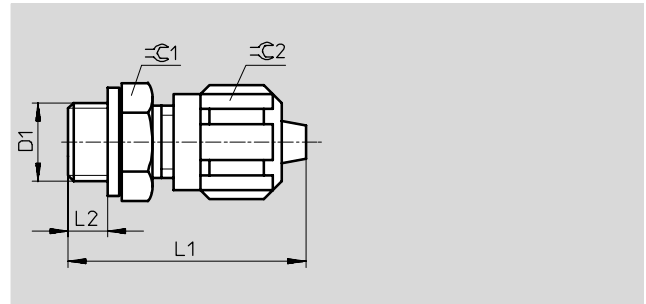

| 尺寸和订货数据 | | | | | | | | | |
|---------|-----------|------|------|----|-----|-----|-------|-------------|-----|
| 接口 D1 | 公称通径 [mm] | 气管内径 | L1 | L2 | ⌀C1 | ⌀C2 | 代号 | 型号 | PU* |
| G1/8 | 3.5 | 4 | 31.5 | 5 | 13 | 12 | 4 035 | CX-1/8-PX-4 | 10 |
| | 5 | 6 | 36.5 | 5 | 13 | 14 | 4 453 | CX-1/8-PX-6 | 10 |
| G1/4 | 3.5 | 4 | 34 | 6 | 17 | 12 | 4 454 | CX-1/4-PX-4 | 10 |
| | 5 | 6 | 39 | 6 | 17 | 14 | 4 036 | CX-1/4-PX-6 | 10 |
| G3/8 | 8 | 9 | 47 | 7 | 22 | 19 | 4 037 | CX-3/8-PX-9 | 1 |

* 包装单元内的数量

快拧接头 LCX/TCX, 用于带金属保护网的气管

技术参数

FESTO

直角快拧接头 LCX

可旋转, 带 2 个密封圈, 用于带金属保护网的气管 PX

材料:
阳极氧化铝

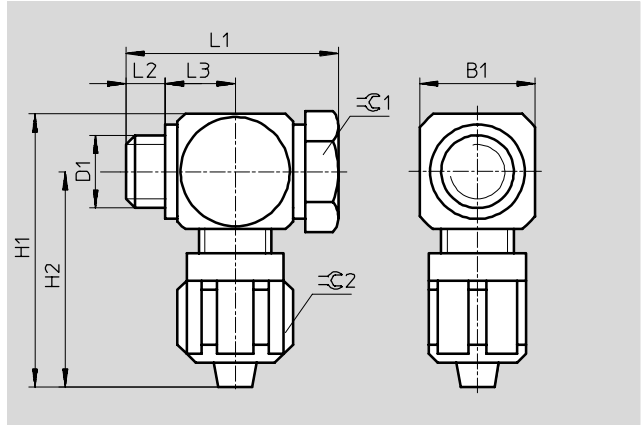

| 尺寸和订货数据 | | | | | | | | | | | | | |
|----------|--------------|------|----|------|-----|------|------|------|-----|-----|-------|--------------|-----|
| 接口 D1 | 公称通径 [mm] | 气管内径 | B1 | L1 | L2 | L3 | H1 | H2 | ≈C1 | ≈C2 | 代号 | 型号 | PU* |
| G1/8 | 3.5 | 4 | 16 | 27.5 | 5.3 | 9.1 | 39.5 | 31.5 | 13 | 12 | 4 041 | LCX-1/8-PX-4 | 1 |
| G1/4 | 5 | 6 | 20 | 35 | 6.8 | 11.6 | 46 | 36 | 17 | 14 | 4 042 | LCX-1/4-PX-6 | 1 |
| G3/8 | 8 | 9 | 25 | 43.5 | 9.3 | 14.1 | 58 | 45.5 | 22 | 19 | 4 043 | LCX-3/8-PX-9 | 1 |

* 包装单元内的数量

T形快拧接头 TCX

可旋转, 带 2 个密封圈, 用于带金属保护网的气管 PX

材料:
阳极氧化铝

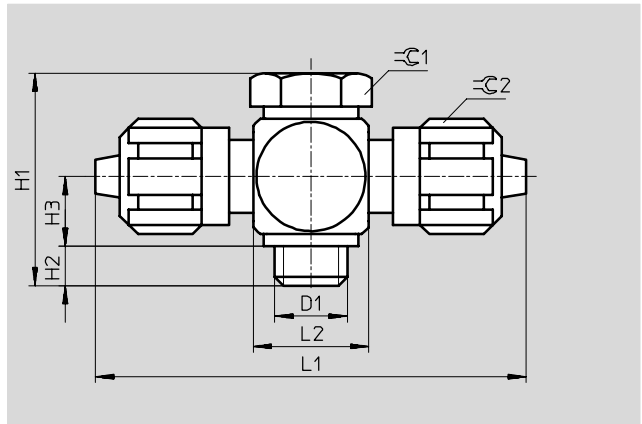

| 尺寸和订货数据 | | | | | | | | | | | | | |
|----------|--------------|------|------|-----|------|----|----|-----|-----|-------|--------------|-----|--|
| 接口 D1 | 公称通径 [mm] | 气管内径 | H1 | H2 | H3 | L1 | L2 | ≈C1 | ≈C2 | 代号 | 型号 | PU* | |
| G1/8 | 3.5 | 4 | 27.5 | 5.3 | 9.1 | 63 | 16 | 13 | 12 | 4 044 | TCX-1/8-PX-4 | 1 | |
| G1/4 | 5 | 6 | 35 | 6.8 | 11.6 | 72 | 20 | 17 | 14 | 4 045 | TCX-1/4-PX-6 | 1 | |
| G3/8 | 8 | 9 | 43.5 | 9.3 | 14.1 | 91 | 25 | 22 | 14 | 4 046 | TCX-3/8-PX-9 | 1 | |

* 包装单元内的数量