



- Short switching times thanks to integrated solenoid valves
- Reliable release of parts under suction via ejector pulse
- 4 nominal sizes:
0.7 ... 2.0 mm
- Compact design
- Protection class IP65

Vacuum generators

Key features

FESTO

Product overview

Vacuum generator

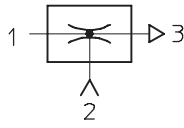

All Festo vacuum generators have a single-stage design and operate according to the venturi principle. The product families described below

have been designed for a wide range of applications. The different performance classes of the individual

product families make it possible to select vacuum generators tailored to suit specific requirements.

Standard and inline ejectors

VN-...

Technical data → Internet: vn



- Nominal size 0.45 ... 3 mm
- Max. vacuum 93%
- Temperature range 0 ... +60 °C
- A range of extremely effective generators suitable for use directly in the workplace
- Available as straight or T-shaped housing
- Low space requirement
- Low-cost
- No wearing parts
- Extremely fast evacuation time
- Vacuum switch (optional)
- Optional with additional functions:
 - integrated eject pulse
 - electric control for vacuum ON/OFF
 - combination of eject pulse and control

VAD-.../VAK-...

Technical data → Internet: vad



- Nominal size 0.5 ... 1.5 mm
- Max. vacuum 80%
- Temperature range -20 ...+80 °C
- Range of vacuum generators with sturdy aluminium casing
- VAK-...: Built-in reservoir
- VAD-...: Connection for additional external reservoir
- Maintenance-free
- VAK-...: Reliable setting down of workpieces

Vacuum generators

Key features

Compact ejectors

VADM-.../VADMI-...

Technical data → Internet: vadm



- Nominal size
0.45 ... 3 mm
- Max. vacuum
88%
- Temperature range
0 ... +60 °C
- Compact design
- Minimal installation work required
- Short response times
- Built-in solenoid valve (on/off)
- VADMI-...: Additional built-in solenoid valve for ejector pulse
- Filter with display
- Air-saving circuit (optional)
- Vacuum switch (optional)
- Reliable setting down of workpieces

VAD-M-.../VAD-M-I-...

→ 6

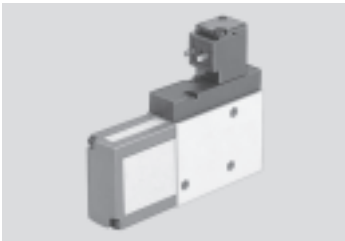

- Nominal size
0.7 ... 2 mm
- Max. vacuum
85%
- Temperature range
0 ... +40 °C
- Compact design
- Minimal installation work required
- Short response times
- Built-in solenoid valve (on/off)
- VAD-M-I-...: Additional built-in solenoid valve for ejector pulse
- Reliable setting down of workpieces

Vacuum generators VAD-M

Key features

At a glance

- Compact and sturdy design
- Short switching times thanks to integrated solenoid valves
- With manual override
- Maintenance-free because there are no moving parts
- With integrated silencer for reducing exhaust noise

Vacuum generators VAD-M...-I...

The compressed air supply of these vacuum generators is controlled by the built-in solenoid valve.

When the electrical power supply is switched on, the valve is actuated and the flow of compressed air from 1 (P) to 3 (R) generates a vacuum at port 2, operating on the ejector principle.

Suction stops when the supply power to the valve is switched off.

Workpieces with smooth, impervious surfaces are picked up and retained.

- Built-in solenoid valve for:
 - Vacuum ON/OFF

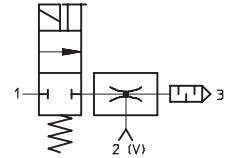

Vacuum generator VAD-M...-I... with ejector pulse

With two integrated solenoid valves for vacuum ON/OFF and ejector pulse for rapid purging of vacuum, plus manual override

Compressed air enters the vacuum generator following the application of a voltage signal to the integrated solenoid valve, thereby creating a vacuum.

Once the voltage is switched off at the vacuum valve (B) and switched on at the ejector valve (A), the vacuum is rapidly purged at connection 2 (V) as a result of the application of pressure.

- Two integrated solenoid valves:
 - Vacuum ON/OFF
 - Ejector pulse

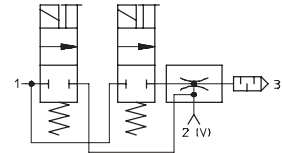

Vacuum generators VAD-M

Peripherals overview and type codes

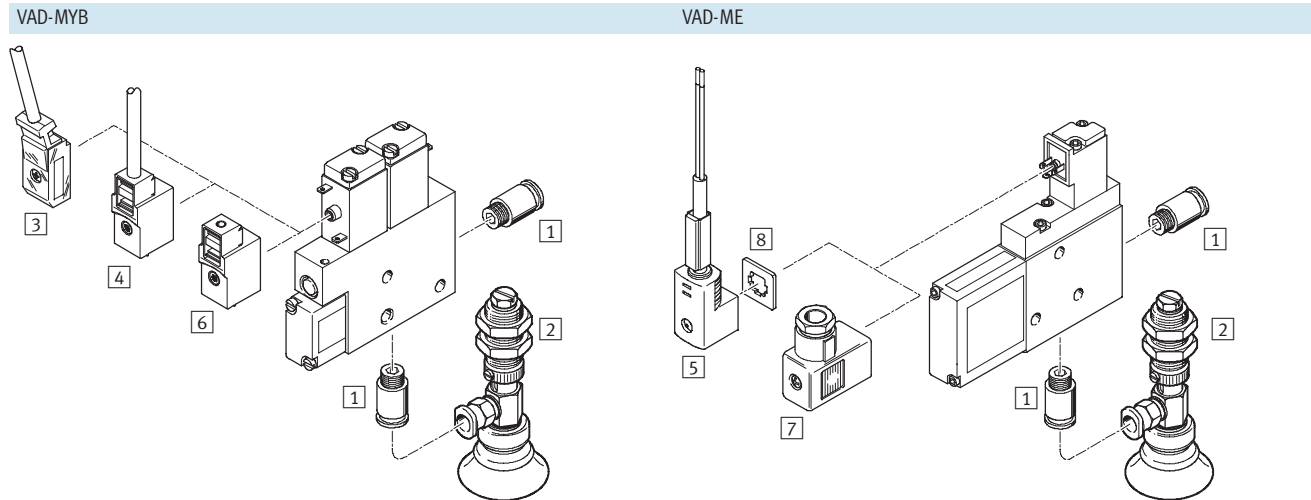

Mounting attachments and accessories			
	VAD-MYB	VAD-ME	→ Page/Internet
1 Push-in fitting QS	■	■	qs
2 Suction gripper ESG	■	■	esg
3 Plug socket with cable KMYZ-2	■	-	kmyz-2
4 Plug socket with cable KMYZ-4	■	-	kmyz-4
5 Plug socket with cable KME-1	-	■	kme-1
6 Plug socket MSSD-ZBZC	-	■	mssd-zbzc
7 Plug socket MSSD-E	-	■	mssd-e
8 Illuminating seal ME-LD	-	■	me-ld

Type		MYB		I		1/8	
VAD	Vacuum generator, electrical						
Solenoid coils							
MYB	Solenoid coil						
ME	Solenoid coil						
Functions							
I	With ejector pulse						
Connection sizes							
1/8	G1/8 thread						
1/4	G1/4 thread						
3/8	G3/8 thread						

- [Symbol] - Note
Possible combinations can be found in the ordering data.

Vacuum generators VAD-M

Technical data

FESTO

Function

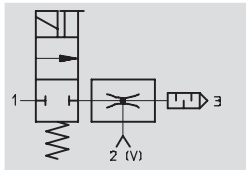

-  - Temperature range
0 ... +40 °C

-  - Operating pressure
1.5 ... 8 bar

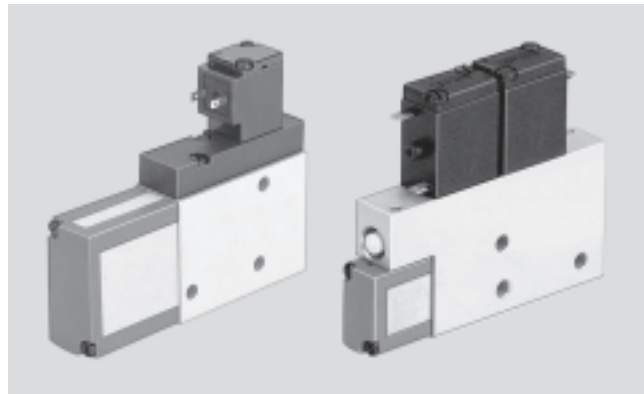

General technical data				
Type	VAD-MYB-...		VAD-ME-...	
Size	G $\frac{1}{8}$	G $\frac{1}{8}$	G $\frac{1}{4}$	G $\frac{3}{8}$
Design	Slim rectangular			
Operating medium	Compressed air, dried, filtered and unlubricated			
Mounting position	Any			
Ejector features	High vacuum			
Type of mounting	Via female threads			
Pneumatic connection 1/2	M5/G $\frac{1}{8}$	G $\frac{1}{8}$ /G $\frac{1}{8}$	G $\frac{1}{8}$ /G $\frac{1}{4}$	G $\frac{1}{4}$ /G $\frac{3}{8}$
Nominal size of laval nozzle [mm]	0.7	0.95	1.4	2.0
Max. vacuum [%]	85			
Operating pressure [bar]	1.5 ... 8			
Duty cycle [%]	100			
Protection class	IP65			

Ambient conditions	
Variant	VAD-M...-...
Ambient temperature [°C]	0 ... +40
Corrosion resistance CRC ¹⁾	2

1) Corrosion resistance class 2 according to Festo standard 940 070

Components requiring moderate corrosion resistance. Externally visible parts with primarily decorative surface requirements which are in direct contact with a surrounding industrial atmosphere or media such as cooling or lubricating agents.

Weights [g]				
Type	VAD-MYB-...		VAD-ME-...	
Size	G $\frac{1}{8}$	G $\frac{1}{8}$	G $\frac{1}{4}$	G $\frac{3}{8}$
VAD-M...	80	125	210	240
VAD-M...-I-...	135	160	250	280

Vacuum generators VAD-M

Technical data

Vacuum ΔP_u as a function of operating pressure p

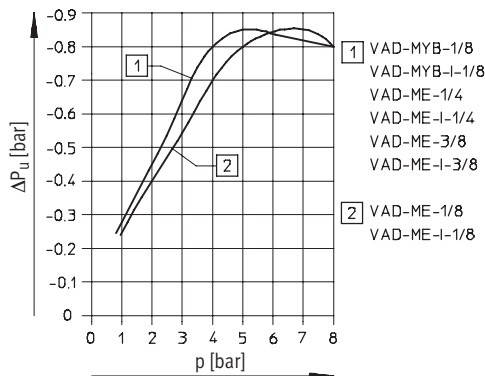

Evacuation time t [s] for 1 litre volume at 6 bar operating pressure

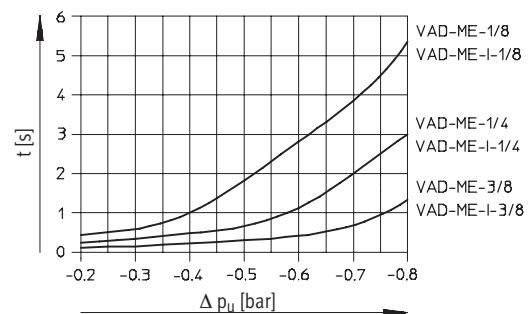
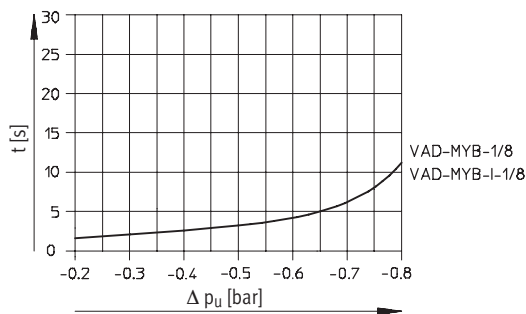

Air consumption Q as a function of operating pressure p

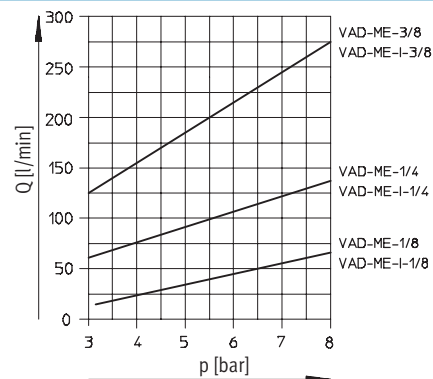
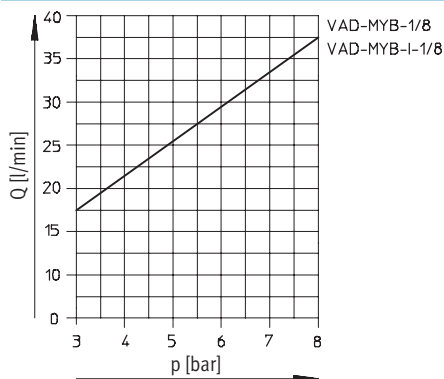

Efficiency η as a function of vacuum Δp at P_{nom} 6 bar

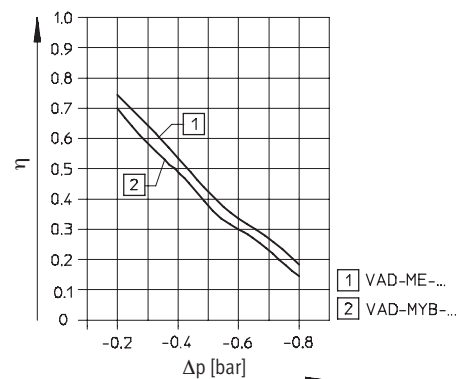

Vacuum generators VAD-M

Technical data

FESTO

Dimensions

VAD-MYB- $\frac{1}{8}$

VAD-ME- $\frac{1}{8}$ / - $\frac{1}{4}$ / - $\frac{3}{8}$

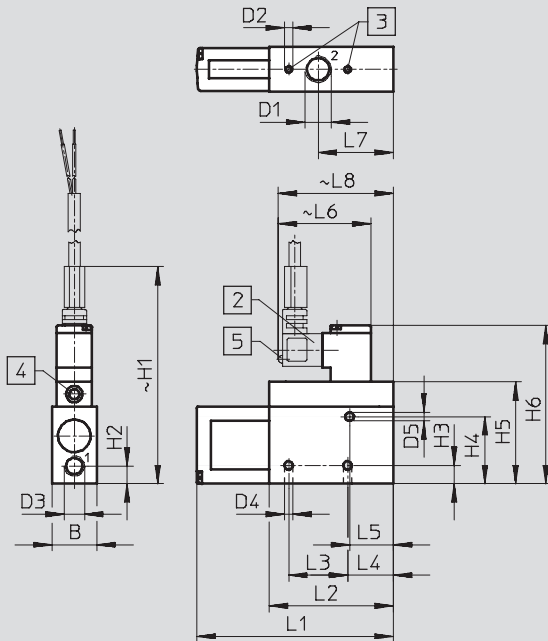
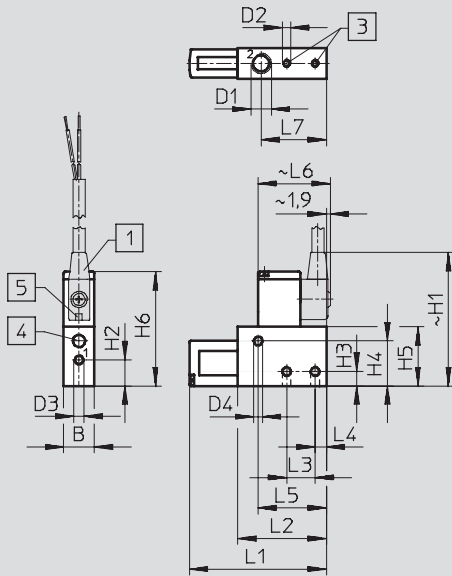

1 Socket type KMYZ-2-24-... with 2-wire cable, 2.5 or 5 m long, \varnothing 3.4 mm (2x 0.25 mm²)

2 Socket type KME-1-24-... with 2-wire cable, 2.5 or 5 m long, \varnothing 5.6 mm (2x 0.75 mm²)

3 Mounting thread
4 Manual override
5 Yellow LED

Type	B	D1	D2	D3	D4	D5	H1	H2	H3	H4
VAD-MYB- $\frac{1}{8}$	15	G $\frac{1}{8}$	M4	M5	4.2	–	62.5	12.7	7	22
VAD-ME- $\frac{1}{8}$	18	G $\frac{1}{8}$	M4	G $\frac{1}{8}$	4.2	3.2	93	14.2	6.5	20
VAD-ME- $\frac{1}{4}$	22	G $\frac{1}{4}$	M4	G $\frac{1}{8}$	4.2	4.2	106.8	8.7	9	33
VAD-ME- $\frac{3}{8}$	22	G $\frac{3}{8}$	M5	G $\frac{1}{4}$	5.2	5.2	113.1	11	10	39

Type	H5	H6	L1	L2	L3	L4	L5	L6	L7	L8
VAD-MYB- $\frac{1}{8}$	29	56	67.2	43.5	14	5.5	33.5	34.6	–	–
VAD-ME- $\frac{1}{8}$	36	64	76	61	27	19	30.5	48	32.5	58
VAD-ME- $\frac{1}{4}$	50	77.8	96.6	61	29	22.5	21.5	48	37	58
VAD-ME- $\frac{3}{8}$	56	84.1	101.8	61	32	23.5	21.5	48	39.5	58

Vacuum generators VAD-M

Technical data

FESTO

Dimensions

VAD-MYB-I-1/8

VAD-ME-I-1/8/-1/4/-3/8

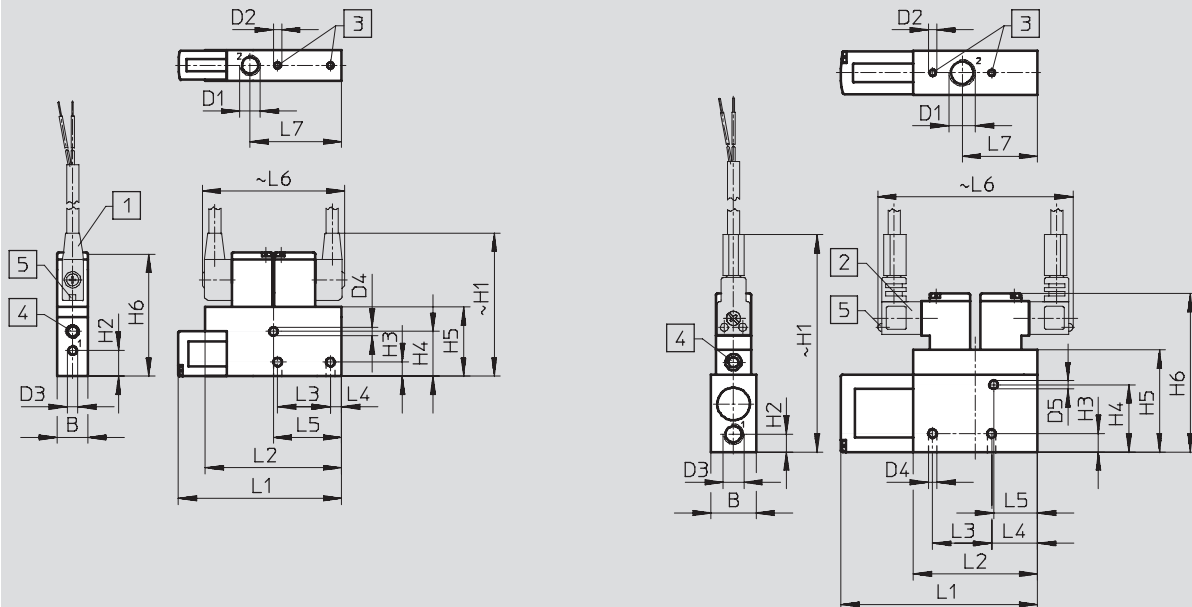

1 Socket type KMYZ-2-24... with 2-wire cable, 2.5 or 5 m long, \varnothing 3.4 mm (2x 0.25 mm²)

2 Socket type KME-1-24... with 2-wire cable, 2.5 or 5 m long, \varnothing 5.6 mm (2x 0.75 mm²)

3 Mounting thread
4 Manual override
5 Yellow LED

Type	B1	D1	D2	D3	D4	D5	H1	H2	H3	H4
VAD-MYB-I-1/8	15	G1/8	M4	M5	4.2	-	67.5	12.7	7	22
VAD-ME-I-1/8	18	G1/8	M4	G1/8	4.2	3.2	93	14.2	6.5	20
VAD-ME-I-1/4	22	G1/4	M4	G1/8	4.2	4.2	106.8	8.7	9	33
VAD-ME-I-3/8	22	G3/8	M5	G1/4	5.2	5.2	113.1	11	10	39

Type	H5	H6	L1	L2	L3	L4	L5	L6	L7
VAD-MYB-I-1/8	34	58.5	80.2	67	26	5.5	33.5	70	45
VAD-ME-I-1/8	36	64	76	61	27	19	30.5	96	32.5
VAD-ME-I-1/4	50	77.8	96.6	61	29	22.5	21.5	96	37
VAD-ME-I-3/8	56	84	101.8	61	32	23.5	21.5	96	39.5

Ordering data

Pneumatic connection	Solenoid coils	Without ejector pulse		With ejector pulse	
		Part No.	Type	Part No.	Type
G1/8	MYB	35 553	VAD-MYB-1/8	35 530	VAD-MYB-I-1/8
G1/8	ME	35 554	VAD-ME-1/8	35 531	VAD-ME-I-1/8
G1/4	ME	35 555	VAD-ME-1/4	35 532	VAD-ME-I-1/4
G3/8	ME	35 556	VAD-ME-3/8	35 533	VAD-ME-I-3/8