

## Valve terminals type 15 CDVI, Clean Design

**FESTO**



# Valve terminals type 15 CDVI, Clean Design

Key features

FESTO

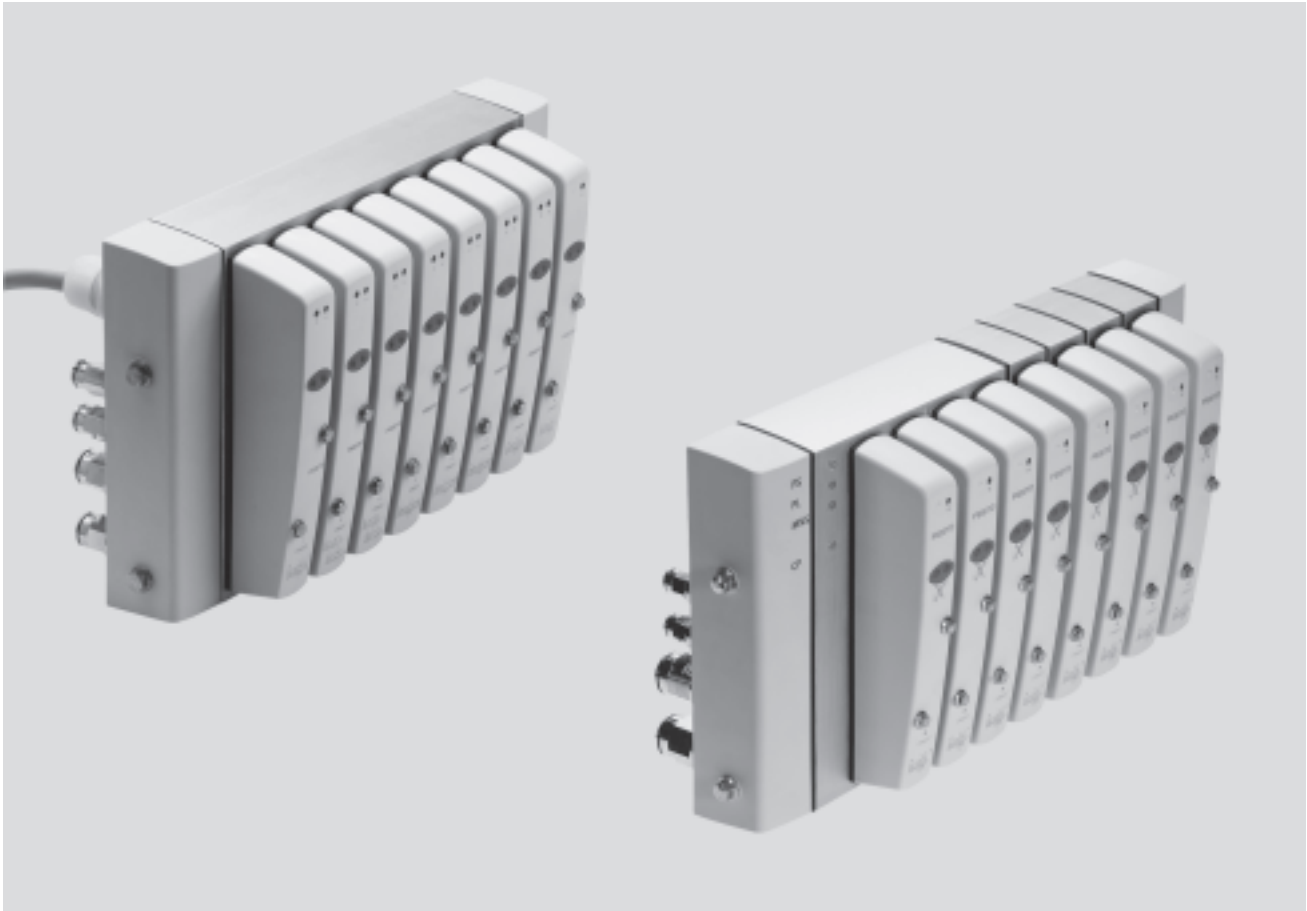

## Innovative

- Proven valve technology combined with a highly resistant polymer material
  - Modular structure with 4 or 8-valve basic block
  - Extension modules with 1 and 2 valve positions
  - Extension modules with 1 and 2 valve positions with separate electrical (fieldbus only) and/or pneumatic additional supply
  - Multi-pin plug connection
  - Fieldbus connection
  - Additional valve terminals and I/O modules can be connected via a CP string extension.
- Additional information  
➔ Internet: ctec

## Versatile

- 4 ... 16 valve positions
- Max. 24 solenoid coils
- Standardised from the individual valve up to multi-pin plug and fieldbus connections
- Flow rates from 300 ... 650 l/min
- Valve width 18 mm
- 1 ... 9 electrical voltage zones
- 1 ... 9 pneumatic pressure zones

## Reliable

- Developed with practical considerations in mind
- Hygienic
  - Corrosion resistant
  - Easy to clean

## Easy to mount

- As is the case with all Festo products, all CDVI and CDSV are fully pre-assembled and equipped according to customer requirements
- With QS...-F fittings on the working lines and end plates
  - Tested for electrical and pneumatic functions

# Valve terminals type 15 CDVI, Clean Design

Key features

FESTO

## CDVI – The requirements



The food industry has stricter hygiene requirements than any other sector. There can therefore be no compromise when it comes to easy cleaning and corrosion resistance.

Result: the CDVI. Developed in close consultation with leading names from the food and packaging industry, the CDVI represents a totally new valve terminal solution for splash zones. The Clean Design valve terminal CDVI has a revolutionary corrosion-resistant and easy-to-clean design that makes it stand out from its competitors.

## CDVI – The solution

### The new Clean Design

#### Valve terminal CDVI – simply a neat solution

Apart from reduced cleaning times, the CDVI also takes less time to install and assemble. Stainless steel control cabinets have become a thing of the past and the electrical connection is now established using the pre-fitted, ready to connect cable. The valve terminal is, of course, supplied fully assembled and in particular tested ex works to IP65, IP66, IP67 and NEMA 4.

This results in minimal installation time.

The valve terminal includes common supply ports and exhausts for all

valves. The common lines are connected to the end plates.

The CDVI is available with four or eight valve positions in the basic designs and can optimally be extended up to 16 valve positions in grids of one or two, taking into consideration the maximum number of coils. Appropriate expansion blocks are used for this.

#### Individual sub-base

An individual sub-base for Clean Design valves (Clean Design Single Valve – CDSV) rounds off the lower end of the product range so that even upstream machines and system components can be incorporated into the Clean Design concept.

### Clean in theory and practice – the CDVI

The requirements for the hygienic design of machine components to DIN EN 1672-2 and DIN ISO 14159 have been implemented in the CDVI. They are easy to clean thanks to:

- no sharp edges
- no small radii
- no crevices where dirt can gather
- space between the valves for easy cleaning
- corrosion-resistant materials

The CDVI can be cleaned using special cleaning agents that are compatible with aluminium, available from the following manufacturers

- Henkel
- Ecolab
- Johnson Diversy
- Kärcher

### Certified cleanliness

The CDVI is certified to HACCP.



**New**  
**2/2-way valve**

**FESTO**

**Valve terminals type 15 CDVI, Clean Design**

Key features

Reduced downtimes:

On-the-spot diagnostics via LEDs

Width 18 mm

Simple electrical connections:

- Multi-pin plug connection with pre-assembled cable
- Fieldbus connection, operating voltage and CP string extension

Functional:

Robust metal thread or pre-assembled QS-F fittings

Fast assembly

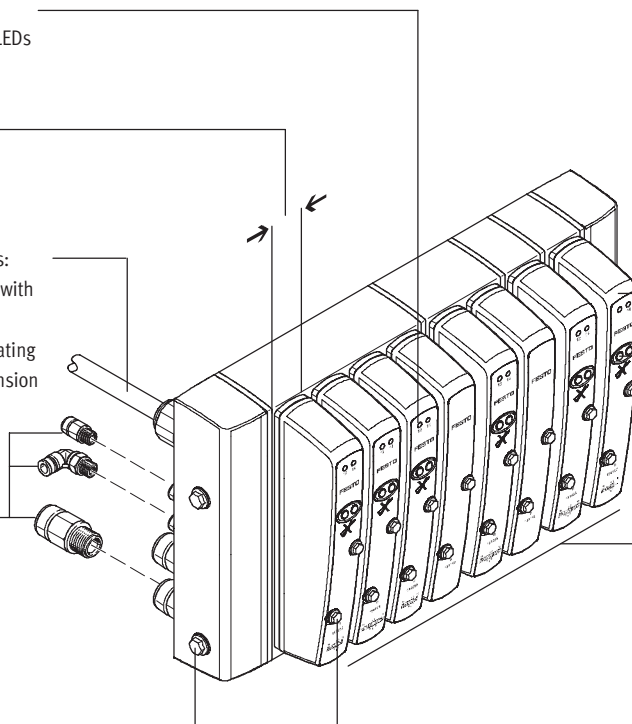

Flexible:

- Max. 16 valve positions with max. 24 solenoid coils
- 1 ... 9 electrical voltage zones
- 1 ... 9 pneumatic pressure zones

Comprehensive range of valve functions

Reliable operation:

Non-detenting manual override

Modular:

- Creation of pressure zones
- Extension modules with 1 and 2 valve positions also with separate electrical (fieldbus only) and/or pneumatic additional supply

**Equipment options**

Valve functions

- |  |  |  |  |
|--|--|--|--|
| <ul style="list-style-type: none"> <li>• 2/2-way valve, normally closed</li> <li>• 2/2-way valve, normally open</li> <li>• 3/2-way valve, normally closed</li> <li>• 3/2-way valve, normally open</li> </ul> | <ul style="list-style-type: none"> <li>• 2x 3/2-way valve, normally closed</li> <li>• 2x 3/2-way valve, normally open</li> <li>• 2x 3/2-way valve, 1x normally open, 1x normally closed</li> </ul> | <ul style="list-style-type: none"> <li>• 5/2-way valve, single solenoid</li> <li>• 5/2-way valve, double solenoid</li> </ul> | <ul style="list-style-type: none"> <li>• 5/3-way valve, mid-position closed</li> <li>• 5/3-way valve, mid-position pressurised</li> <li>• 5/3-way valve, mid-position exhausted</li> </ul> |
|--|--|--|--|

Special features

**Individual valve**

- Electrical connection via multi-pin cable

**Multi-pin terminal**

- Max. 16 valve positions
- Max. 24 solenoid coils
- Compressed air supply possible via both end plates as well as power supply module
- 1 ... 9 pressure zones
- Detergent resistant PVC cable already assembled
- Cable length 5 m or 10 m

**Fieldbus terminal**

- Max. 16 valve positions
- Max. 24 solenoid coils
- Compressed air supply possible via both end plates as well as power supply module
- 1 ... 9 pressure zones
- 1 ... 9 voltage zones
- Enhanced diagnostic function
- Easy to clean connections at the rear

**CP string extension**

- Additional valve terminals or
  - Electrical I/O modules.
- Additional information  
➔ Internet: ctec

# Valve terminals type 15 CDVI, Clean Design

Key features

## The features

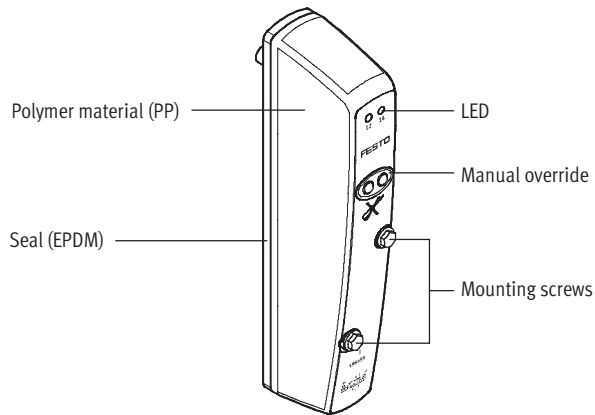

## The ideal range for the food industry

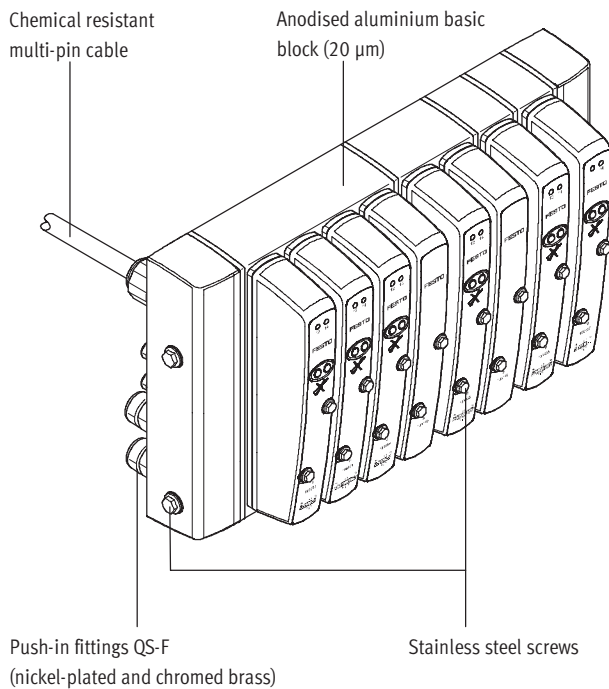

Choose from

- a wide range comprising actuators to accessories in corrosion resistant designs that are easy to clean,
- as well as valves,
- stainless steel fittings and flow control valves and
- tubing approved for use in the food industry.

All have been tested using cleaning agents from leading manufacturers.

## The accessories

Tubing PLN



Push-in fitting QS-F/QSL-F...

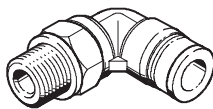
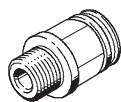

You should only use accessories that have been suggested by Festo. This is the only way of ensuring optimum performance from the CDVI in the following areas:

- Resilience
- Corrosion resistance class
- Ease of cleaning

# Valve terminals type 15 CDVI, Clean Design

Key features

FESTO

## Individual connection

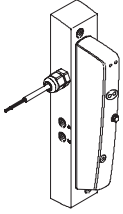

Valves can also be used on individual sub-bases for actuators further away from the valve terminal.

The electrical connection is established via a 10 m pre-assembled PVC cable.

## Multi-pin plug connection

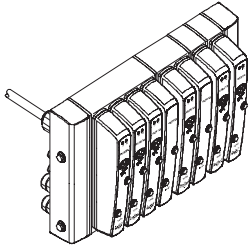

Control signals from the controller to the valve terminal are transmitted via a pre-assembled multi-wire cable or a self-assembly multi-pin plug connection, which substantially reduces installation time.

Valve terminals with multi-pin plug connections can be equipped with 4 to 16 valve positions with max. 24 solenoid coils.

Designs

- Multi-pin cable, 5 m long, pre-assembled with open wire ends
- Multi-pin cable, 10 m long, pre-assembled with open wire ends

## Fieldbus connection

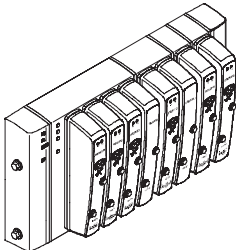

An integrated fieldbus node manages the communication connection to a higher-order PLC. This enables a space-saving pneumatic and electronic solution.

Valve terminals with fieldbus interfaces can be equipped with 4 to 16 valve positions with max. 24 solenoid coils.

Designs

- DeviceNet connection 2x M12
- Ethernet Powerlink on request

 Note

The basic blocks of the valve terminals can be extended by a maximum of 8 valve positions. The extension modules used are of no relevance here.

# Valve terminals type 15 CDVI, Clean Design

Key features

## CP string extension

The optional string extension enables an additional valve terminal and I/O modules to be connected to Fieldbus Direct. A CP string of the CPI installation system is integrated in the fieldbus node as an extension. Different input and output modules as well as CPV and CPA valve terminals can be connected.

The maximum length of the CP string extension is 10 metres, which means that the extension modules can be mounted directly on-site. All of the required electrical signals are transmitted via the CP cable, which in turn means that no further installation is needed on the extension module.

The CP string interface offers:

- 16 input signals
- 16 output signals for output modules 24 V DC or solenoid coils
- Logic and sensor supply for the input modules
- Load voltage supply for the valve terminals
- Logic supply for the output module

Additional information

➔ Internet: ctec

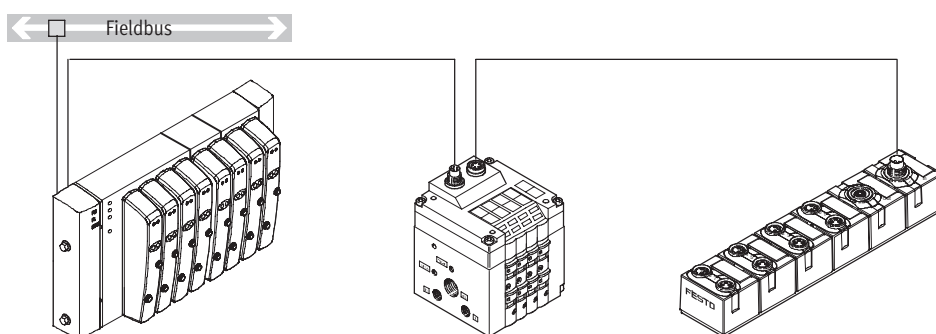

- - Note

Valve terminals can be ordered quickly and easily online.

The convenient product configurator can be found on:

➔ Internet: type 15

# Valve terminals type 15 CDVI, Clean Design

Peripherals overview

FESTO

## Overview – Clean Design valve terminal

Individual sub-base

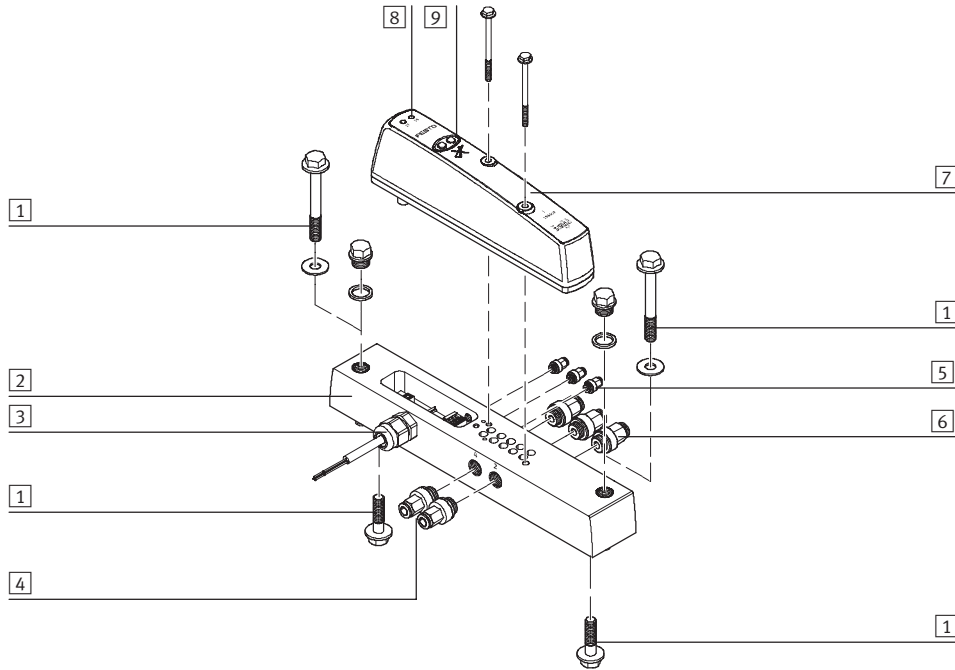

	Brief description	→ Page/Internet	
1	Mounting kit	Mounting from above or below	34
2	Sub-base for individual valve	–	31
3	Individual electrical connection	–	–
4	Push-in fitting	For working lines	34
5	Push-in fitting	For pilot air supply and venting, venting hole	quick star
6	Push-in fitting	For compressed air supply and venting	34
7	Valve	–	31
8	LED display	–	–
9	Manual override	For each solenoid coil, non-detenting	–

All valves on the valve terminal CDVI can be assembled on the individual sub-base CDSV. The individual sub-base CDSV has a connection for external pilot air supply, is pre-assembled with valve and 10 m PVC cable and is fully inspected before shipment.

Assembled push-in fittings included on request. A Clean Design mounting kit comprising two screws (18 mm and 40 mm) and two stainless steel blanking plugs permits mounting from above or below. If you have included fittings with your order, the pressure

compensation hole is also equipped with a QS fitting. The collected exhaust air from the pilot solenoid coils of the valves is drawn off via the pressure compensation hole (venting hole) on the rear side.

 Note  
All ports and mounting holes that are not required must be sealed with a blanking plug.  
Exception: venting hole



# Valve terminals type 15 CDVI, Clean Design

Peripherals overview

FESTO

## Overview – Clean Design valve terminal

Valve terminal with multi-pin plug connection

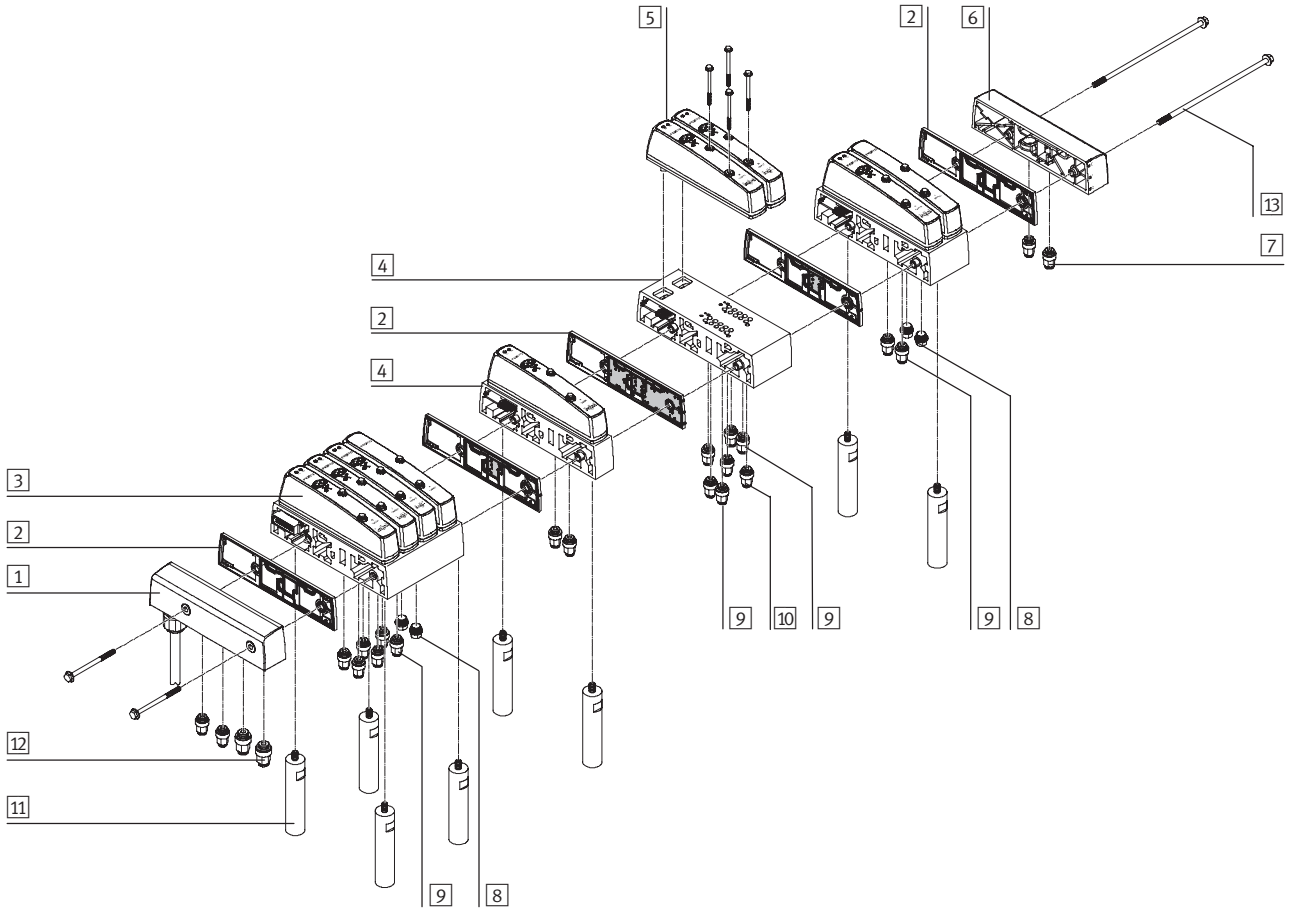

	Brief description	→ Page/Internet
1	Left-hand end plate With multi-pin plug connection	33
2	Separator plate	33
3	4/8-valve basic block	32
4	Extension module/power supply module	32
5	Valves	31
6	Right-hand end plate	33
7	Push-in fitting For right-hand end plate	34
8	Blanking plug	34
9	Push-in fitting For working lines	34
10	Push-in fitting For power supply module	34
11	Spacer bolt	34
12	Push-in fitting For left-hand end plate	34
13	Screw kit For attaching the extension modules to the basic block	34

The collected exhaust air from the pilot solenoid coils of the valves is drawn off via the pressure compensation hole (venting hole) on the rear side.

If you have included fittings with your order, the pressure compensation hole is also equipped with a QS fitting.

If extension modules are added to the valve terminal later, the appropriate screw kit must be ordered (page 34).

 Note  
All ports and mounting holes that are not required must be sealed with a blanking plug.  
Exception: venting hole

# Valve terminals type 15 CDVI, Clean Design

Peripherals overview

FESTO

## Overview – Clean Design valve terminal

Valve terminal with fieldbus connection

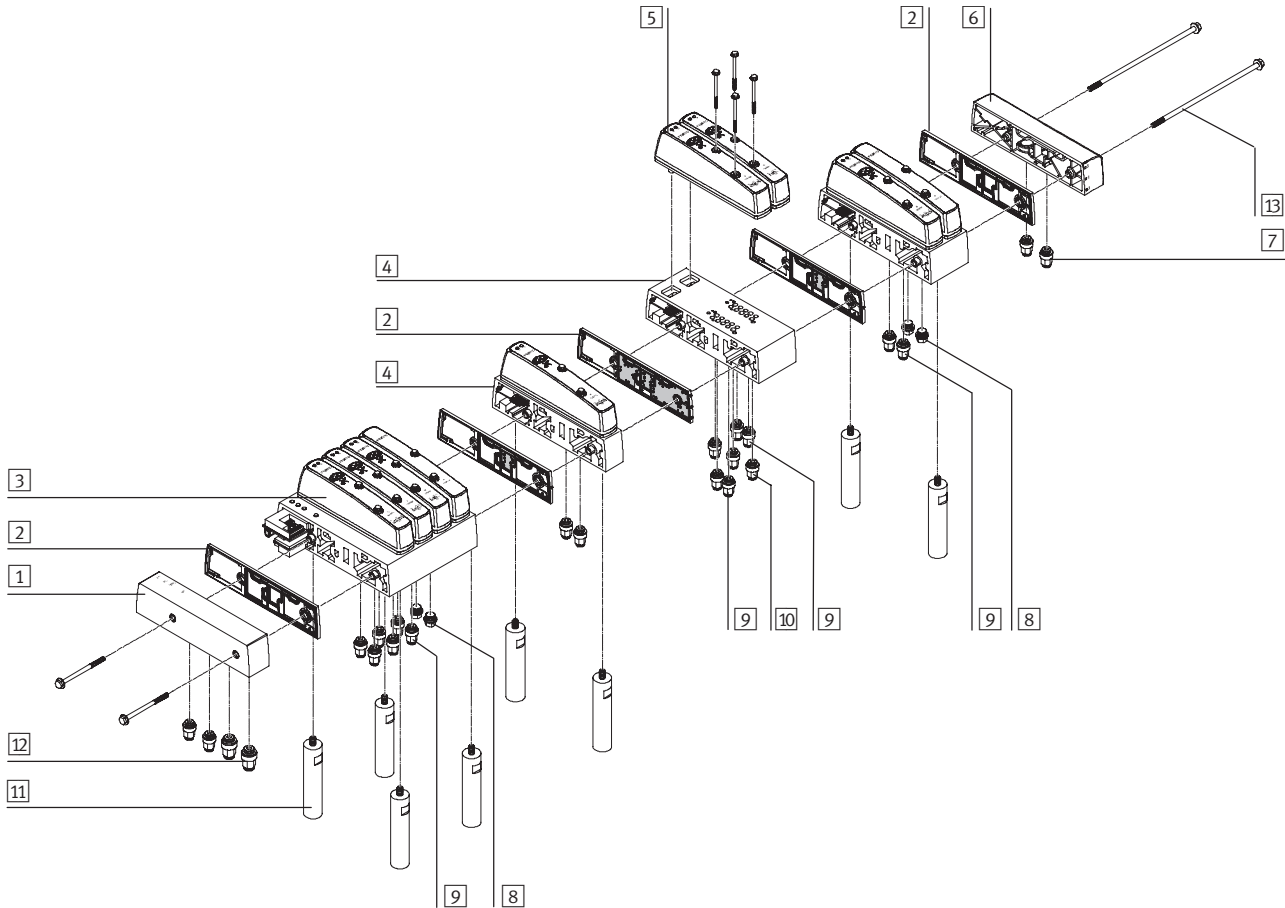

	Brief description	→ Page/Internet
1	Left-hand end plate With fieldbus connection	33
2	Separator plate	33
3	4/8-valve basic block	32
4	Extension module/power supply module	32
5	Valves	31
6	Right-hand end plate	33
7	Push-in fitting For right-hand end plate	34
8	Blanking plug	34
9	Push-in fitting For working lines	34
10	Push-in fitting For power supply module	34
11	Spacer bolt	34
12	Push-in fitting For left-hand end plate	34
13	Screw kit For attaching the extension modules to the basic block	34

The collected exhaust air from the pilot solenoid coils of the valves is drawn off via the pressure compensation hole (venting hole) on the rear side.

If you have included fittings with your order, the pressure compensation hole is also equipped with a QS fitting.

If extension modules are added to the valve terminal later, the appropriate screw kit must be ordered (page 34).

 Note  
All ports and mounting holes that are not required must be sealed with a blanking plug.  
Exception: venting hole

## Valve terminals type 15 CDVI, Clean Design

Key features – Pneumatic components

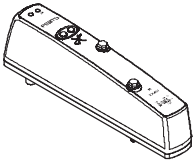
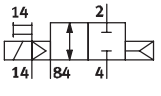
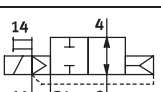
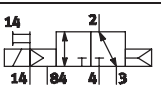
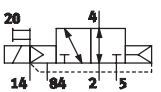
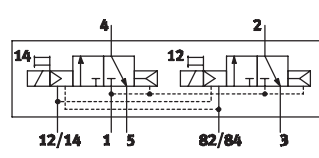
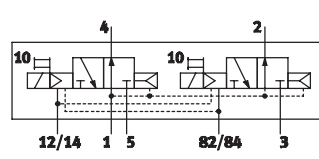
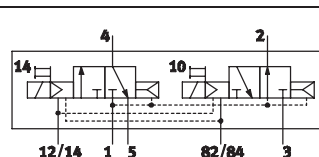
Valves			
	Code	Circuit symbol	Description
	R		2/2-way single solenoid valve <ul style="list-style-type: none"> <li>• Normally closed</li> <li>• Pneumatic spring return</li> <li>• Suitable for vacuum</li> <li>• Supplied externally with supply air</li> </ul>
	S		2/2-way single solenoid valve <ul style="list-style-type: none"> <li>• Normally open</li> <li>• Pneumatic spring return</li> <li>• Suitable for vacuum</li> <li>• Supplied externally with supply air</li> </ul>
	X		3/2-way single solenoid valve <ul style="list-style-type: none"> <li>• Normally closed</li> <li>• Pneumatic spring return</li> <li>• Suitable for vacuum</li> <li>• Supplied externally with supply air</li> </ul>
	W		3/2-way single solenoid valve <ul style="list-style-type: none"> <li>• Normally open</li> <li>• Pneumatic spring return</li> <li>• Suitable for vacuum</li> <li>• Supplied externally with supply air</li> </ul>
	K		2x 3/2-way single solenoid valve <ul style="list-style-type: none"> <li>• Normally closed</li> <li>• Pneumatic spring return</li> <li>• Not suitable for vacuum</li> </ul>
	N		2x 3/2-way single solenoid valve <ul style="list-style-type: none"> <li>• Normally open</li> <li>• Pneumatic spring return</li> <li>• Not suitable for vacuum</li> </ul>
	H		2x 3/2-way single solenoid valve <ul style="list-style-type: none"> <li>• 1x normally closed, 1x normally open</li> <li>• Pneumatic spring return</li> <li>• Not suitable for vacuum</li> </ul>

 Note

A filter must be installed upstream of valves operated in vacuum mode. This prevents any foreign matter in the intake air getting into the valve (e.g. when operating a suction cup).

# Valve terminals type 15 CDVI, Clean Design

Key features – Pneumatic components

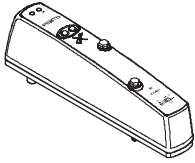
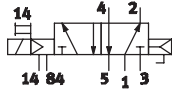
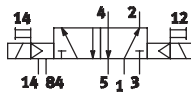
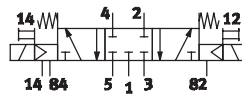
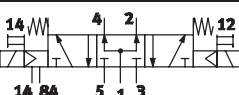
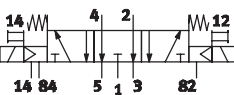
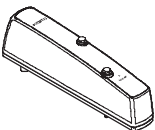
Valves and cover			
	Code	Circuit symbol	Description
	M		5/2-way single solenoid valve <ul style="list-style-type: none"> <li>• Pneumatic spring return</li> <li>• Suitable for vacuum</li> </ul>
	J		5/2-way double solenoid valve <ul style="list-style-type: none"> <li>• Suitable for vacuum</li> </ul>
	G		5/3-way valve <ul style="list-style-type: none"> <li>• Mid-position closed</li> <li>• Mechanical spring return</li> <li>• The piston rod side of the cylinder remains under pressure in the normal valve position</li> <li>• Suitable for vacuum</li> </ul>
	B		5/3-way valve <ul style="list-style-type: none"> <li>• Mid-position pressurised</li> <li>• Mechanical spring return</li> <li>• The piston rod of the cylinder advances when the valve is in the normal position due to the differential piston areas</li> <li>• Suitable for vacuum</li> </ul>
	E		5/3-way valve <ul style="list-style-type: none"> <li>• Mid-position exhausted</li> <li>• Mechanical spring return</li> <li>• In the normal valve position, the piston rod can be moved freely</li> <li>• Suitable for vacuum</li> </ul>
	A	Cover for valve position	For valve terminal only

# Valve terminals type 15 CDVI, Clean Design

Key features – Pneumatic components

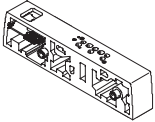
1-valve extension modules (valve terminal only)			
	Code	Designation	Description
	B1	Extension module for 1 valve position	Without additional pneumatic supply
	D1	Extension module for 1 valve position	Duct 1 separated with separating seal on left for creating a pressure zone with separate supply air
	F1	Extension module for 1 valve position	Ducts 3 and 5 separated with separating seal on left
	H1	Extension module for 1 valve position	Ducts 1, 3 and 5 separated with separating seal on left for creating a pressure zone with separate supply and exhaust air
	T	Only one solenoid coil per valve position	

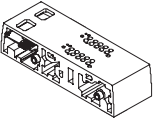
2-valve extension modules (valve terminal only)			
	Code	Designation	Description
	B	Extension module for 2 valve positions	Without additional pneumatic supply
	D	Extension module for 2 valve positions	Duct 1 separated with separating seal on left for creating a pressure zone with separate supply air
	F	Extension module for 2 valve positions	Ducts 3 and 5 separated with separating seal on left
	H	Extension module for 2 valve positions	Ducts 1, 3 and 5 separated with separating seal on left for creating a pressure zone with separate supply and exhaust air
	K	Extension module for 2 valve positions	Duct 1 separated with separating seal on left with separate supply port for creating pressure zones
	I	Extension module for 2 valve positions	Ducts 1, 3 and 5 separated with separating seal on left with separate supply and exhaust ports for creating pressure zones
T	Only one solenoid coil per valve position		

Additional function for 1 and 2-valve extension modules (valve terminal only)			
	Code	Designation	Description
	V	Extension module with separate electrical power supply	Only in combination with fieldbus
	P	Extension module with separate supply and exhaust ports	
	C	Extension module with separate electrical power supply as well as separate supply and exhaust ports	Only in combination with fieldbus

 Note

The structure of the valve terminal with extension modules and their additional functions can be conveniently defined using the product configurator. You can find it on:

→ Internet: type 15

# Valve terminals type 15 CDVI, Clean Design

Key features – Pneumatic components



## Modularity

Consistently modular valve terminal in a grid of 4 ... 16 valve positions/ 8 ... 24 solenoid coils. See sample representation on right.

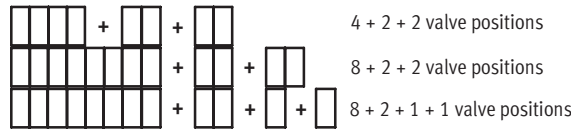

## Pilot air supply

The valves used are pneumatically piloted solenoid valves. The ports on the valve terminal differ for the following pilot air supply types:

- internal pilot air supply
- external pilot air supply

The pilot air supply duct 12/14 is supplied from the duct 1 supply air (internal pilot air supply) or via a separate pilot air supply in the left-hand end plate (external pilot air supply).

A separate pilot air supply is required in any event if supply pressure is less than 3 bar or greater than 8 bar. In this case it is advisable to restrict the pilot air supply to max. 8 bar with a suitable regulator.

The pilot air supply is selected by including a corresponding code letter in the order code (end plates/ compressed air supply code U, V, Y, Z).

## Pneumatic pressure zones

CDVI offers a number of options for creating pressure zones, if different working pressures are required.

Pressure zones are created by isolating the internal supply ducts between the basic block and extension module or by using extension modules with separate supply ports with an appropriate separator plate.

A maximum of two different pressure zones can be created on valve terminals with one extension module without separate supply port. The compressed air is supplied at both ends through the end plates. Up to three different pressure zones can be created on valve terminals with two extension modules. In this case, the compressed air is supplied via the two end plates as well as via the first extension module with separate supply port.

If more than three pressure zones are required, extension modules with a separate supply port must be used. Up to nine pressure zones are possible taking into consideration the maximum valve positions and number of coils. In this case, the compressed air is supplied via the two end plates as well as via the separate supply ports of the respective extension modules.

Separator plates are integrated ex-works as per your order. Separator plates can be distinguished through their coding, even when the valve terminal is assembled. A label on the right-hand end plate makes it easier to allocate the separator plates when the valve terminal is assembled.

Separator plates		
Pictorial examples	Coding	Notes
		Separator plate No duct separation
		Separator plate Duct 1 separated Ducts 3 and 5 open
		Separator plate Duct 1 open Ducts 3 and 5 separated
		Separator plate Ducts 1, 3 and 5 separated

- - Note  
Normally only duct 1 is closed.  
Ducts 3 and 5 or 1, 3 and 5 can also be closed for special applications.

# Valve terminals type 15 CDVI, Clean Design

Key features – Pneumatic components

## Examples: Compressed air supply and pilot air supply

### Internal pilot air supply

#### Code U, Y

The diagram opposite shows an example of the configuration and connection of the compressed air supply with internal pilot air supply. Port 12/14 on the left-hand end plate is tightly sealed. The pilot air is supplied internally via the right-hand end plate.

Separator plates can be used optionally to create pressure zones.

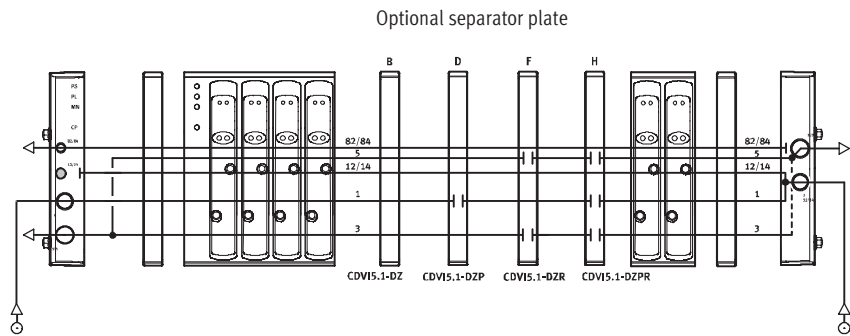

### External pilot air supply

#### Code V, Z

The diagram opposite shows an example of the configuration and connection of the compressed air supply with external pilot air supply. Port 12/14 on the left-hand end plate is equipped with a fitting for this purpose.

Separator plates can be used optionally to create pressure zones. In this case it is advisable to restrict the pilot air supply to max. 8 bar with a suitable regulator.

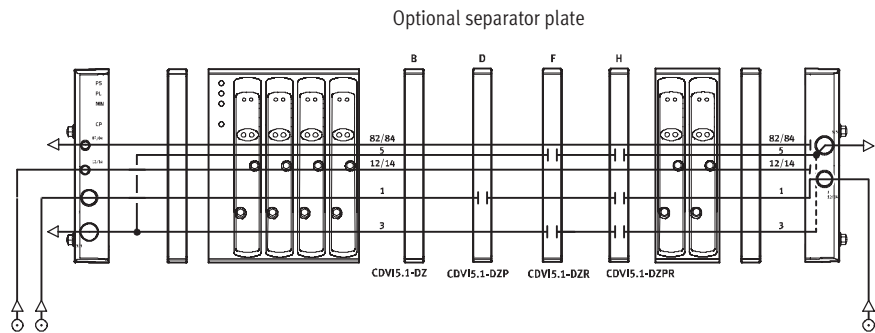

## Examples: Creation of pressure zones

The CDVI facilitates the creation of up to 9 pressure zones. The diagram opposite shows an example of the configuration and connection of three pressure zones using separator plates with an external pilot air supply of 3 ... 8 bar.

#### Note

Particular attention must be paid to the assembly of the right-hand end plate when converting a valve terminal from internal to external pilot air supply.

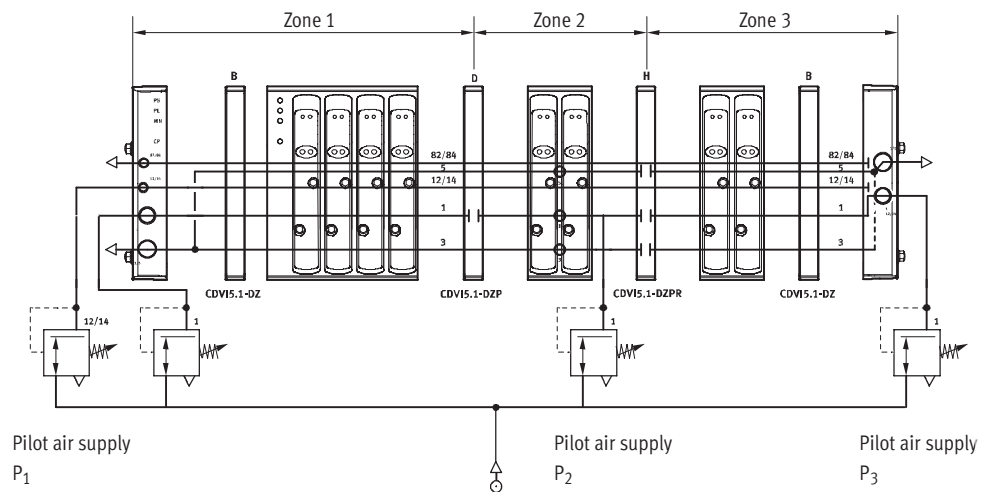

# Valve terminals type 15 CDVI, Clean Design

Key features – Pneumatic components

## Individual sub-base assembly

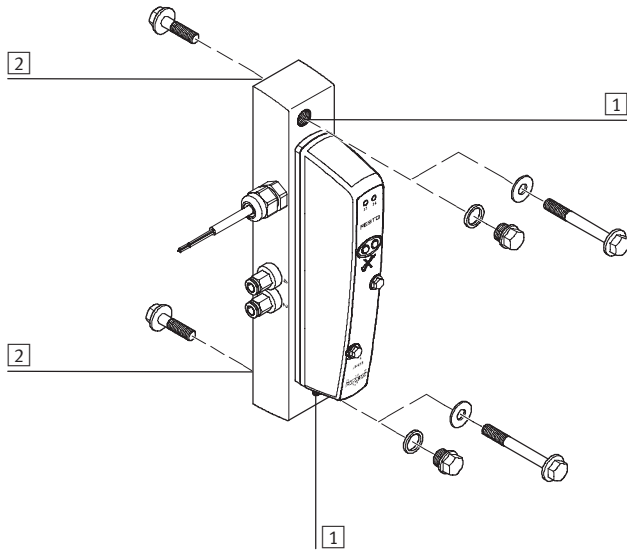

- 1 Hole for front mounting (CDSV) using M6 screws; the hole can be covered with blanking plug G1/8 if not required
- 2 Hole for rear mounting (CDSV) using M6 screws

## Valve terminal assembly

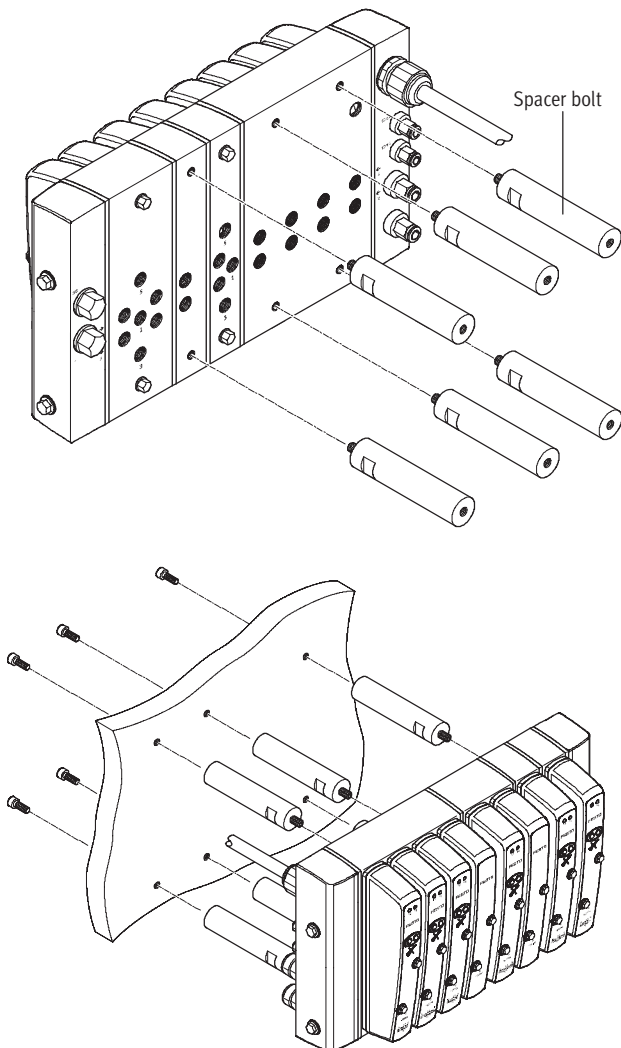

The CDVI can be mounted directly on earthed mounting surfaces using the four threaded holes in the basic block and the spacer bolts ordered via the order code (accessories order code Y).

The CDVI can be mounted in any position. However, the selected mounting position should allow for the cleaning off of dirt and the draining of cleaning agent.

 Note

If extension modules are added to the valve terminal at a later stage, the following points must be observed:

- Basic block:  
Always attach using 4 spacer bolts
- Extension modules:  
After the second module, max. 4 extension modules between 2 attachment points
- Appropriate screw kit for attaching the extension modules to the basic block (page 34)



# Valve terminals type 15 CDVI, Clean Design

Key features – Pneumatic components

## Manual override (MO)

Manual override with automatic return (non-detenting)

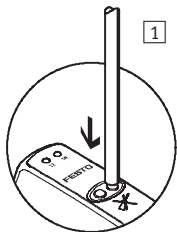

- 1 Press in the stem of the manual override with a pointed object. Valve is then actuated.

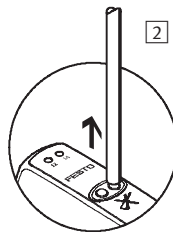

- 2 Remove the pointed object. Mechanical force pushes the stem of the manual override back. Valve returns to initial position (not with 5/2-way double solenoid valve, code J).

## Display and control elements – Individual sub-base

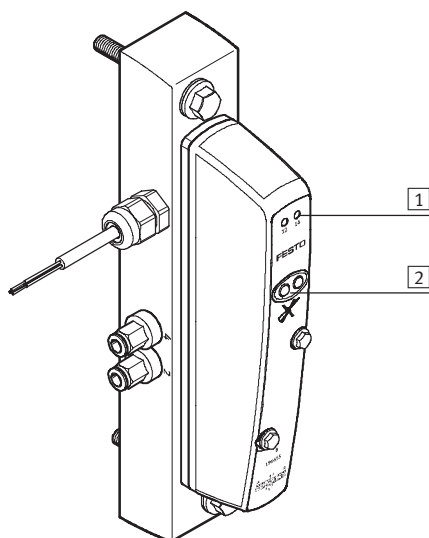

- 1 Yellow LEDs (one per solenoid coil)  
2 Non-detenting manual override (per solenoid coil)

## Display and control elements – Valve terminal

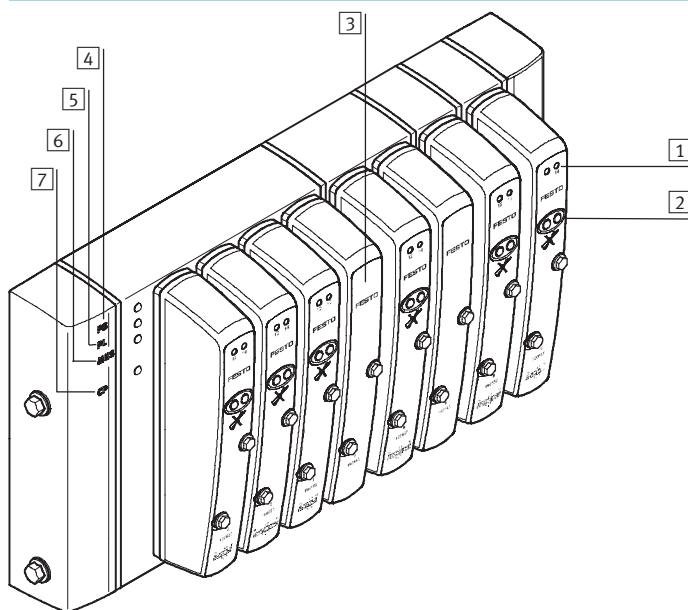

- 1 Yellow LEDs (one per solenoid coil)  
2 Non-detenting manual override (per solenoid coil)  
3 Vacant valve position with blanking plate

With fieldbus:

- 4 Green PS LED  
“Power System”  
Operating voltage of electronics  
5 Green PL LED  
“Power Load”  
Load voltage of valves  
6 Green/red MNS LED  
“Module/Network Status”  
7 Green/red CP LED  
“Compact Performance”  
CP extension modules

# Valve terminals type 15 CDVI, Clean Design

Key features – Pneumatic components

FESTO

## Connections – Individual sub-base

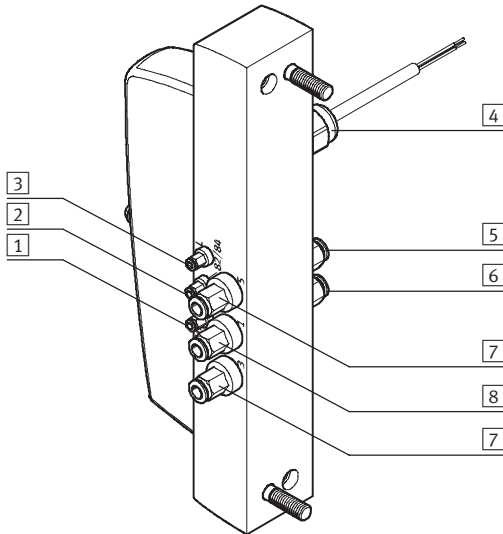

- 1 Pilot exhaust port (82/84)
- 2 Pilot air supply port (12/14)
- 3 Pressure compensation port/venting hole
- 4 Electrical connection
- 5 Working line (4) per valve
- 6 Working line (2) per valve
- 7 Exhaust port (3/5)
- 8 Supply port (1)

## Connections – Valve terminal

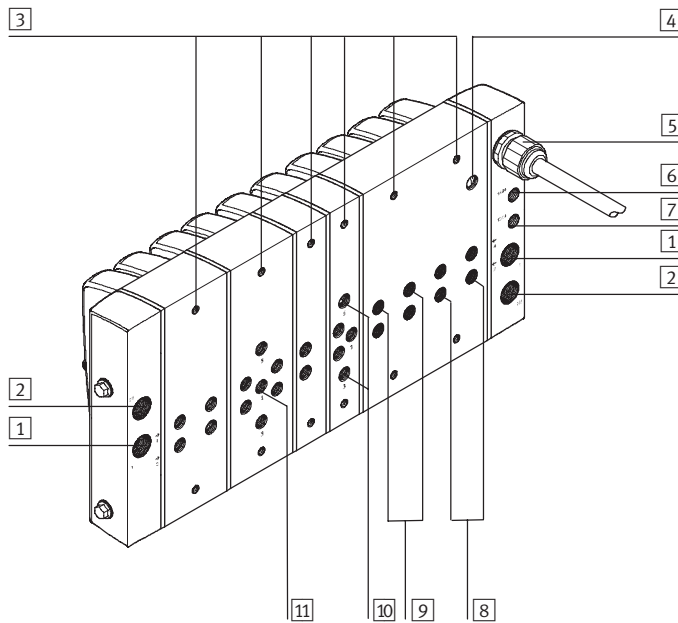

- 1 Supply port (1)
- 2 Exhaust port (3/5)
- 3 Threaded holes for spacer bolts (top and bottom)
- 4 Pressure compensation port/venting hole
- 5 Electrical multi-pin plug connection
- 6 Pilot exhaust port (82/84)
- 7 Pilot air supply port (12/14)
- 8 Working line (2) per valve
- 9 Working line (4) per valve
- 10 Exhaust ports (3 + 5) with extension module
- 11 Supply port (1) with extension module

Line		Port code (ISO 5599)	Connection size (ISO 228)	Connector fitting <sup>1)</sup>
Supply air/vacuum	1	1	G $\frac{3}{8}$	- In the left-hand/right-hand end plate
	11		G $\frac{1}{8}$	- In the extension module with additional supply
Exhaust air	2	3/5	G $\frac{3}{8}$	- In the left-hand/right-hand end plate
	10	3, 5	G $\frac{1}{8}$	- In the extension module with additional supply
Pressure compensation	4	-	G $\frac{1}{8}$	- In the basic block
Pilot exhaust air	6	82/84	G $\frac{1}{8}$	- In the left-hand end plate
Pilot air supply	7	12/14	G $\frac{1}{8}$	- In the left-hand end plate
Working line/vacuum	8	2, 4	G $\frac{1}{8}$	- In the basic block
	9		G $\frac{1}{8}$	- In the extension module with additional supply

1) The CDVI valve terminal can be pre-equipped with QS-F push-in fittings depending on the order.

# Valve terminals type 15 CDVI, Clean Design

Key features – Electrical components

## Electrical power as a result of current reduction

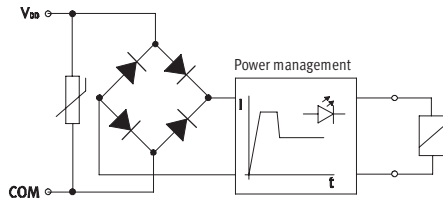

Each solenoid coil is protected with a spark arresting protective circuit as well as against polarity reversal. All valve types are also equipped with

integrated current reduction.

Advantages:

- Lower power consumption
- Lower temperature rise

## Terminal allocation – Cable for individual sub-base CDSV

Core colour	Allocation
Brown	Solenoid coil 14
Black	Solenoid coil 12 (not on 5/2-way single solenoid valve)
Blue	com <sup>1)</sup>

1) 0 V for positive switching valves; 24 V can be connected for negative switching control signals

## Terminal allocation – Multi-pin cable<sup>1)</sup>

Pin	Address	Valve position/solenoid coil		Wire colour <sup>2)</sup>
		4-valve basic block	8-valve basic block	
A01	0	0/14	0/14	WH
A02	1	0/12	0/12	GN
B01	2	1/14	1/14	YE
B02	3	1/12	1/12	GY
C01	4	2/14	2/14	PK
C02	5	2/12	2/12	BU
A03	6	3/14	3/14	RD
A04	7	3/12	3/12	VT
B03	8		4/14	GY PK
B04	9		4/12	RD BU
C03	10		5/14	WH GN
C04	11		5/12	BN GN
A05	12		6/14	WH YE
A06	13		6/12	YE BN
B05	14		7/14	WH GY
B06	15		7/12	GY BN
C05	16	–		WH PK
C06	17	–		PK BN
A07	18	–		WH BU
A08	19	–		BN BU
B07	20	–		WH RD
B08	21	–		BN RD
C07	22	–		WH BK
C08	23	–		BN BK
B10	com	0 V <sup>3)</sup>	0 V <sup>3)</sup>	BN
C10	com	0 V <sup>3)</sup>	0 V <sup>3)</sup>	BK
–	–	–	–	GY GN <sup>4)</sup>

1) Max. 24 solenoid coils

2) To IEC 757

3) 0 V for positive switching control signals; connect 24 V for negative switching control signals; mixed operation is not permitted.

4) This core is not used and can be cut off.

# Valve terminals type 15 CDVI, Clean Design

Key features – Electrical components



## Address allocation – Valves with multi-pin plug

A valve position on the CDVI valve terminal always occupies 2 addresses on the basic block, even if one of these is equipped with a blanking plate.

Addresses should be assigned in ascending consecutive order. The numbering goes from left to right.

A valve terminal extension occupies 2 addresses on an extension module for 1 valve position and 4 addresses on an extension module for 2 valve positions.

If the extension module is additionally configured with the option T (only one solenoid coil per valve position), only one address is occupied per valve position.

Example: Address allocation for a CDVI valve terminal with a basic block with 8 valves and 2 extension modules for 2 valve positions

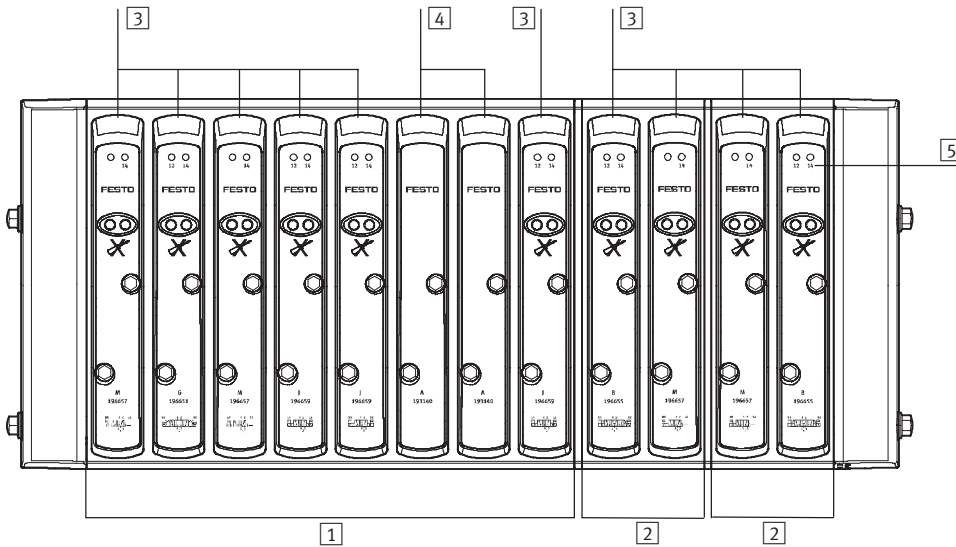

- 1 Basic block with 8 valve positions: 16 addresses
- 2 Extension module for 2 valve positions: 4 addresses  
=> 24 addresses (coils)
- 3 Valves
- 4 Vacant positions
- 5 Number of the solenoid coil

## Addressing order for valves with fieldbus

The CDVI terminal occupies 8, 16 or, depending on the extension, up to 24 addresses, regardless of the number of solenoid coils.

A 4-valve basic block occupies 8 addresses and an 8-valve basic block 16 addresses, while the 1-valve and 2-valve extension modules occupy 2 and 4 addresses respectively.

If a valve position is equipped with a valve with 2 pilot solenoid coils, the following allocation applies:

- Pilot solenoid coil 14 occupies the less significant address
- Pilot solenoid coil 12 occupies the more significant address

The more significant address is not used in valves with only one pilot solenoid coil.

The addresses of the CDVI valve terminal are allocated from left to right, while the addresses of the individual valve positions are allocated from right (pilot solenoid coil 14) to left (pilot solenoid coil 12).

**Note**  
If the extension module is additionally configured with the option T (only one solenoid coil per valve position), only one address is occupied per valve position.

Example: Addressing order for a basic block with 4 valve positions and two extension modules for 2 valve positions

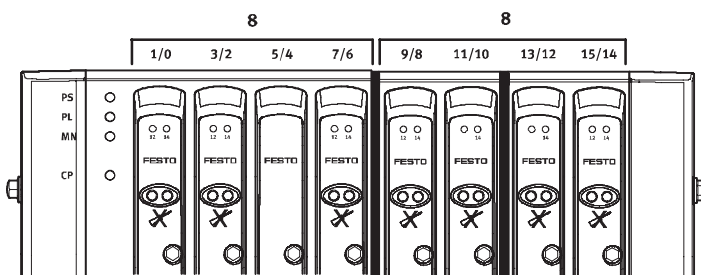

**Note**  
Address shifts can occur if one expansion block is replaced by another type of expansion block. For example, replacing a 2-valve bi expansion block with a 2-valve mono expansion block shifts the address allocation to the right by 2 addresses.

# Valve terminals type 15 CDVI, Clean Design

Key features – Electrical components

## Fieldbus Direct

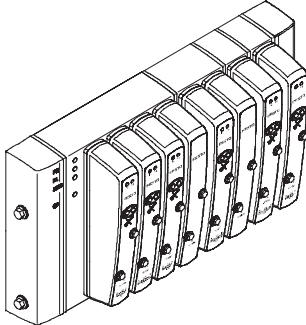

Fieldbus Direct is a system for the compact connection of a valve terminal of various sizes to different fieldbus standards.

The CP string extension option allows the functions and components of the CP installation system to be used.

The I/O modules and cables for the CP string extension are ordered using the order code for the CP installation system.

Additional information

➔ Internet: ctec

## Enhanced fieldbus diagnostics

Enhanced diagnostics (supplied load voltage) is only possible with new basic blocks and new expansion blocks with additional electrical power supply (code C and V).

These new blocks can be identified by the 16-pin terminal strip (old = 12-pin) as well as the designation printed on the PCB. The green "Power Loss" LED on

the basic block flashes in the case of undervoltage/voltage failure of the additional power supply at the extension module (code C and V).



Note

Enhanced diagnostics is not possible with combinations of old and new expansion blocks.

## Electrical voltage zones

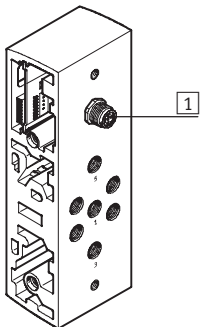

Up to 9 electrical voltage zones can be created with the help of extension modules with separate electrical power supply (code V and C), taking into consideration the maximum valve positions and number of coils.

By using an extension module with separate electrical power supply, the solenoid coils following to the right including the coils of the extension module are supplied separately with electrical power or disconnected separately.

1 Connection of separate electrical power supply

# Valve terminals type 15 CDVI, Clean Design

Configuration and ident. code

FESTO

## Valve terminal configurator

Online via: → [www.festo.com](http://www.festo.com)

A valve terminal configurator is available online to help you select a suitable CDVI valve terminal.

Like all valve terminals, the CDVI is ordered using an ident. code. This ident. code specifies the valve functions, the number of valves, vacant positions as well as the additional functions and the type of compressed air supply.

As is the case with all Festo products, all CDVI and CDSV are supplied:

- fully pre-assembled
- fitted with QS...-F fittings on the working lines and end plates on request
- tested for electrical function
- tested for pneumatic function

- securely packaged
- manuals can be downloaded free of charge

Ordering system for type 15 CDVI  
→ Internet: type 15

## Example of an ident. code

15P - K10 - 4A - UR - 3MJ-B-JG - E + Y

<b>Valve terminal family</b>		15P	-	K10	-	4A	-	UR	-	3MJ-B-JG	-	E	+	Y
15P	Type 15 CDVI													
<b>Electrical connection</b>		K10	-	K10	-	4A	-	UR	-	3MJ-B-JG	-	E	+	Y
K10	Multi-pin plug, cable 10 m													
<b>Valve positions/type of connection</b>		4	-	K10	-	4A	-	UR	-	3MJ-B-JG	-	E	+	Y
4	Valves on basic block													
		A	-	K10	-	4A	-	UR	-	3MJ-B-JG	-	E	+	Y
<b>Pneumatic supply/type of seal</b>		U	-	K10	-	4A	-	UR	-	3MJ-B-JG	-	E	+	Y
<b>Selected valve equipment...</b>		3M	-	K10	-	4A	-	UR	-	3MJ-B-JG	-	E	+	Y
...basic block (position 0 ... 3)														
		J	5/2-way double solenoid valve											
		B	Extension module for 2 valve positions											
		J	5/2-way double solenoid valve											
		G	5/3-way valve, mid-position closed											
<b>Manual</b>		E	-	K10	-	4A	-	UR	-	3MJ-B-JG	-	E	+	Y
<b>Type of mounting</b>		Y	-	K10	-	4A	-	UR	-	3MJ-B-JG	-	E	+	Y

# Valve terminals type 15 CDVI, Clean Design

Instructions for use

FESTO

## Equipment

Operate system equipment with unlubricated compressed air if possible. Festo valves and cylinders are designed so that, if used as designated, they will not require additional lubrication and will still achieve a long service life.

The quality of compressed air downstream from the compressor must correspond to that of unlubricated compressed air. If possible, do not operate all of your system equipment with lubricated compressed air. The lubricators should, where possible, always be installed directly upstream of the consuming actuator.

Incorrect additional oil and too high an oil content in the compressed air reduces the service life of a valve terminal.

Use Festo special oil OFSW-32 or the alternatives listed in the Festo catalogue (as specified in DIN 51524 HLP32; basic oil viscosity 32 CST at 40 °C).

### Bio-oils



When using bio-oils (oils which are based on synthetic or native ester, e.g. rapeseed oil methyl ester), the maximum residual oil content of 0.1 mg/m<sup>3</sup> must not be exceeded (see ISO 8573-1 Class 2).

### Mineral oils

When using mineral oils (e.g. HLP oils to DIN 51524, parts 1 through 3) or similar oils based on poly-alpha-olefins (PAO), the maximum residual oil content of 5 mg/m<sup>3</sup> must not be exceeded (see ISO 8573-1 Class 4). A higher residual oil content irrespective of the compressor oil cannot be permitted, as the basic lubricant would be flushed out over time.

# Valve terminals type 15 CDVI, Clean Design

Technical data

-  - Flow rate  
300 ... 650 l/min
-  - Valve width  
24 mm

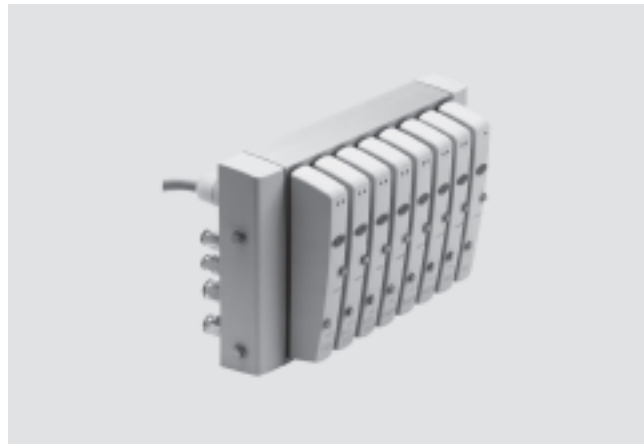

General technical data		
		CDVI
Constructional design		Piston spool valve
Actuation type		Electrical
Width	[mm]	24
Nominal diameter	[mm]	5
Lubrication		Lifetime lubrication, PWIS-free (free of paint-wetting impairment substances)
Type of mounting		Via 2 screws (DIN 6921)
• Valves and end plate		Via spacer bolts
• Valve terminal		
Tightening torque of valve/ blanking plate	[Nm]	0.8
Exhaust function		With flow control
Mounting position		Any
Manual override		Non-detenting
Pneumatic connections		
Supply port	1	G $\frac{3}{8}$ (G $\frac{1}{8}$ on extension module CDVI5.0-EBX and CDSV)
Exhaust port	3/5	G $\frac{3}{8}$ (G $\frac{1}{8}$ on extension module CDVI5.0-EBX and CDSV)
Working lines	2/4	G $\frac{1}{8}$
Pilot air supply port	12/14	G $\frac{1}{8}$ (M5 on CDSV)
Pilot exhaust air port	82/84	G $\frac{1}{8}$ (M5 on CDSV)
Pressure compensation port		G $\frac{1}{8}$ (M5 on CDSV)

Valve switching times [ms]													
Valve function order code		R	S	X	W	K	N	H	M	J	G	B	E
Switching times	on	14	14	10.3	10.3	10	10	10	12	-	12	12	12
	off	10	10	14.1	14.1	22	22	22	22	-	25	25	25
	change-over	-	-	-	-	-	-	-	-	10	17	17	17



# Valve terminals type 15 CDVI, Clean Design

Technical data

Operating and environmental conditions												
Valve function order code	R	S	X	W	K	N	H	M	J	G	B	E
Operating medium	Filtered compressed air, lubricated or unlubricated											
Grade of filtration [μm]	40											
Operating pressure [bar]	-0.9 ... +10				3 ... 10 <sup>2)</sup>				-0.9 ... +10			
Operating pressure for valve terminal with internal pilot air supply [bar]	3 ... 8 (not available on the CDSV)											
Pilot pressure [bar]	3 ... 8											
Storage temperature [°C]	-20 ... +40											
Operating temperature [°C]	-5 ... +50											
Temperature of medium [°C]	-5 ... +50											
CE mark (see declaration of conformity)	To EU EMC Directive											
Food industry approval	DIN EN ISO 14159											
Corrosion resistance class CRC <sup>1)</sup>	3											

- 1) Corrosion resistance class 3 as per Festo standard 940 070  
 Components subject to higher corrosion stress. Externally visible parts with primarily decorative surface requirements which are in direct contact with a normal industrial environment or media such as solvents and cleaning agents.
- 2) 2x 3/2-way valves not suitable for vacuum

## Pilot pressure with external pilot air supply

Switch-on pilot pressure of 5/2-way and 5/3-way valves and 3/2-way valves with external air supply (EXT)

Switch-on pilot pressure of 3/2-way valves

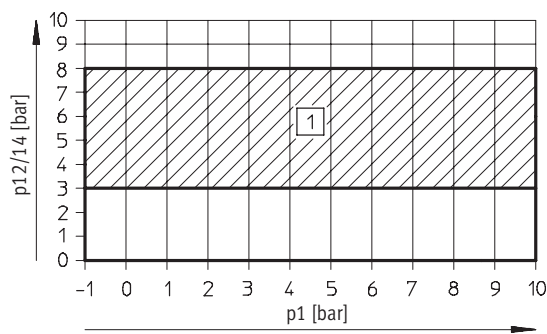

1) Permissible pressure range

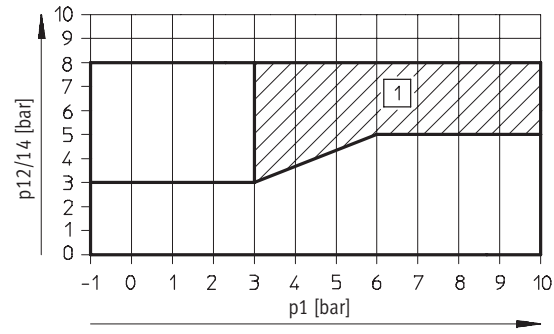

1) Permissible pressure range

# Valve terminals type 15 CDVI, Clean Design

FESTO

Technical data

Electrical data		R	S	X	W	K	N	H	M	J	G	B	E
Valve function order code													
Electromagnetic compatibility		Interference immunity tested to EN 61000-6-2											
Nominal operating voltage	[V DC]	24, reverse polarity protected											
Operating voltage	[V DC]	21.6 ... 26.4											
Minimum power supply requirement	[V/ms]	0.4 minimum voltage increase time to reach the high-current phase											
Residual ripple	[Vss]	4											
Switch-on current consumption													
• per solenoid coil at 24 V (with LEDs)	[mA]	Typ. 120											
• total at 24 V and max. number of solenoid coils (with LEDs)	[A]	Typ. 2.88											
Current consumption during operation													
• per solenoid coil at 24 V (with LEDs)	[mA]	Min. 26											
• total at 24 V and max. number of solenoid coils (with LEDs)	[A]	Typ. 0.62											
Electrical power consumption per solenoid coil (with LED)	[W]	2.88											
Duty cycle		100%											
Protection class to EN 60529		IP65, IP66, IP67, NEMA 4 (fully assembled)											
Vibration resistance		To DIN/IEC 68/EN 60068, Part 2-6 and IEC 721/EN 60 068 Part 2-3											
Shock resistance		To DIN/IEC 68/EN 60068, Part 2-27 and IEC 721											
Continuous shock resistance		To DIN/IEC 68/EN 60068, Part 2-29: +/- 15 g at 6 ms, 1000 cycles											

Multi-pin cable	
Cable design	[mm <sup>2</sup> ] 25x0.34
Bending radius during flexible use	Min. 15x cable Ø
Outer Ø	[mm] Approx. 11.4

Materials		R	S	X	W	K	N	H	M	J	G	B	E
Valve function order code													
Blanking plate		Polypropylene (PP), thermoplastic rubber (TPE), polyamide (PA)											
Manifold sub-base		Aluminium (anodised min. 20 µm)											
Blanking plug		Polybutylene terephthalate (material no.: 1.4303 or 1.4301)											
End plate		Polypropylene											
Screws		Polybutylene terephthalate (material no.: 1.4303 or 1.4301)											
Spacer bolt		Aluminium (anodised min. 20 µm)											
Valve		Aluminium, polyacetate (POM), polyphenylene sulphide (PPS), polyamide (PA), nitrile rubber (NBR), brass (Ms), steel (St), polycarbonate (PC), polypropylene (PP)											

# Valve terminals type 15 CDVI, Clean Design

Technical data

Weight [g]	Approx. weights	
	CDVI multi-pin plug	CDVI fieldbus
Basic block with 4 valve positions <sup>1)</sup>	1,050	1,320
Basic block with 8 valve positions <sup>1)</sup>	2,090	2,360
Extension module for 1 valve position with/ without additional supply <sup>2)</sup>	255	255
Extension module for 2 valve positions with/ without additional supply <sup>2)</sup>	510	510
Valve	210	
Blanking plate	85	
Left-hand/right-hand end plate	120	
Separator plate	30-40	
CDSV individual sub-base <sup>3)</sup>	690	
Spacer bolt (2 pieces)	160	
Connecting cable per metre	168	

1) Basic block, without: separator plates, right-hand and left-hand end plates, pneumatic fittings, cables, valves and cover plates.

2) Extension module, without: separator plate, pneumatic fittings, valves and cover plates.

3) Individual sub-base, without: pneumatic fittings and valve.

Nominal flow rate [l/min]	Valve function order code											
	R	S	X	W	K	N	H	M	J	G	B	E
Pressurised	500	300	500	500	300	300	300	650	650	650	650	400
Exhausted	500	300	500	500	300	300	300	650	650	650	400	650
Mid-position	–	–	–	–	–	–	–	–	–	–	150	150

# Valve terminals type 15 CDVI, Clean Design

Technical data

FESTO

## Dimensions

Download CAD data → [www.festo.com](http://www.festo.com)

### Individual sub-base

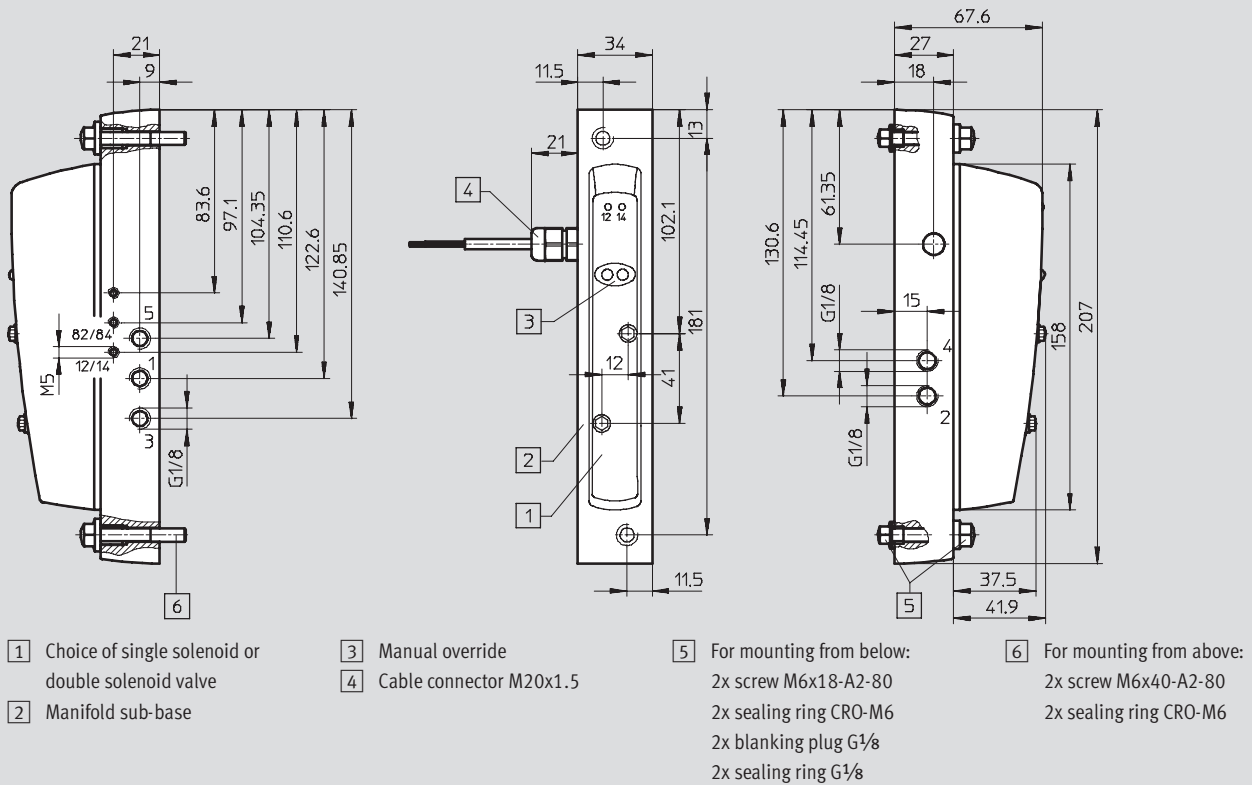

# Valve terminals type 15 CDVI, Clean Design

Technical data



## Dimensions

Download CAD data → [www.festo.com](http://www.festo.com)

Basic block with 4 valve positions and extension modules, design with multi-pin plug connection

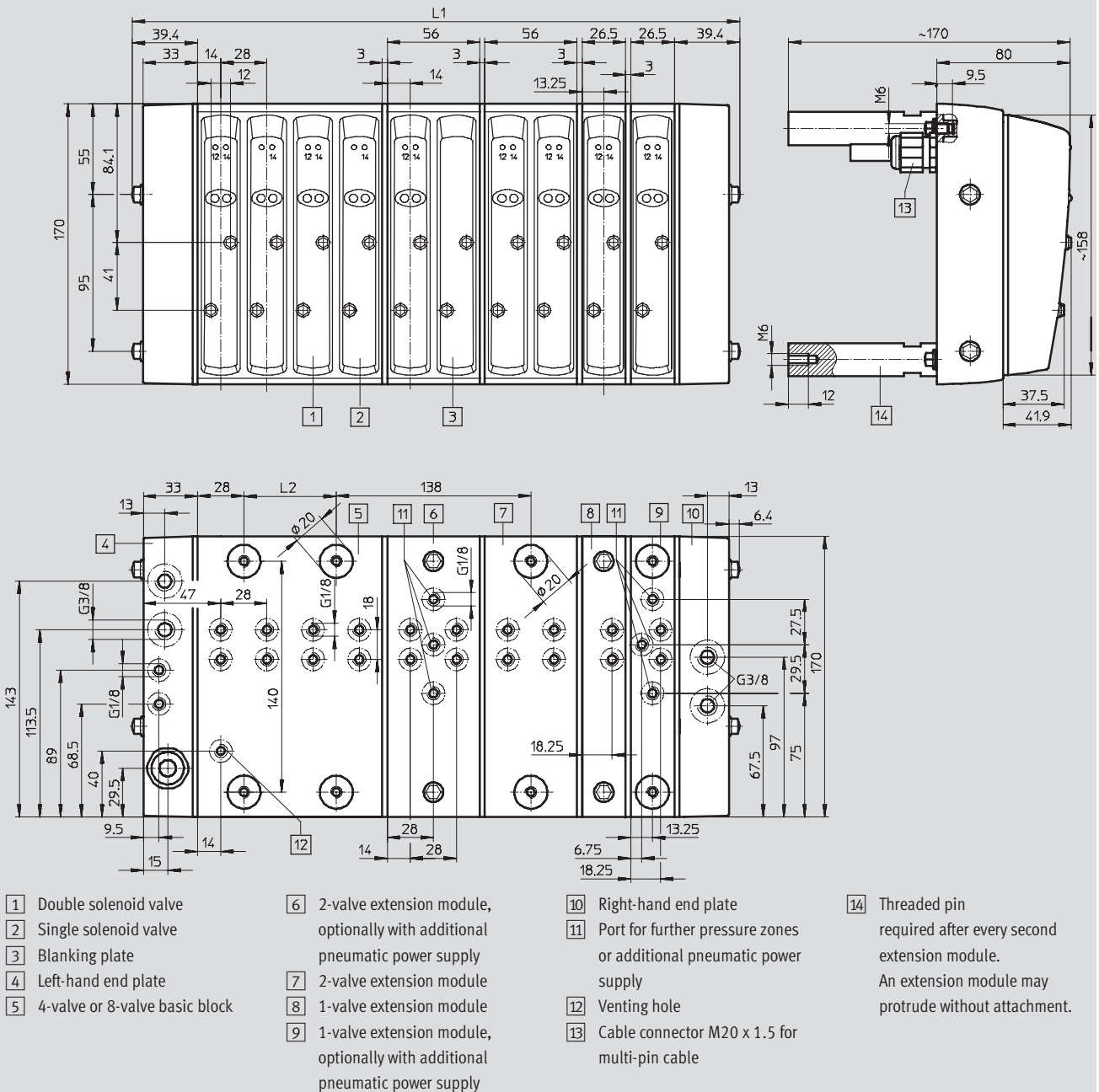

Basic block		Valve positions												
		5	6	7	8	9	10	11	12	13	14	15	16	
4-valve	L1	190.8	220.3	249.8	279.3	308.8	338.3	367.8	397.3	426.8	456.3	485.8	515.3	544.8
	L2	56												
8-valve	L1	302.8					332.3	361.8	391.3	420.8	450.3	479.8	509.3	538.8
	L2	168												

# Valve terminals type 15 CDVI, Clean Design

Technical data

FESTO

## Dimensions

Download CAD data → [www.festo.com](http://www.festo.com)

Basic block with 4 valve positions and extension modules, design with fieldbus connection

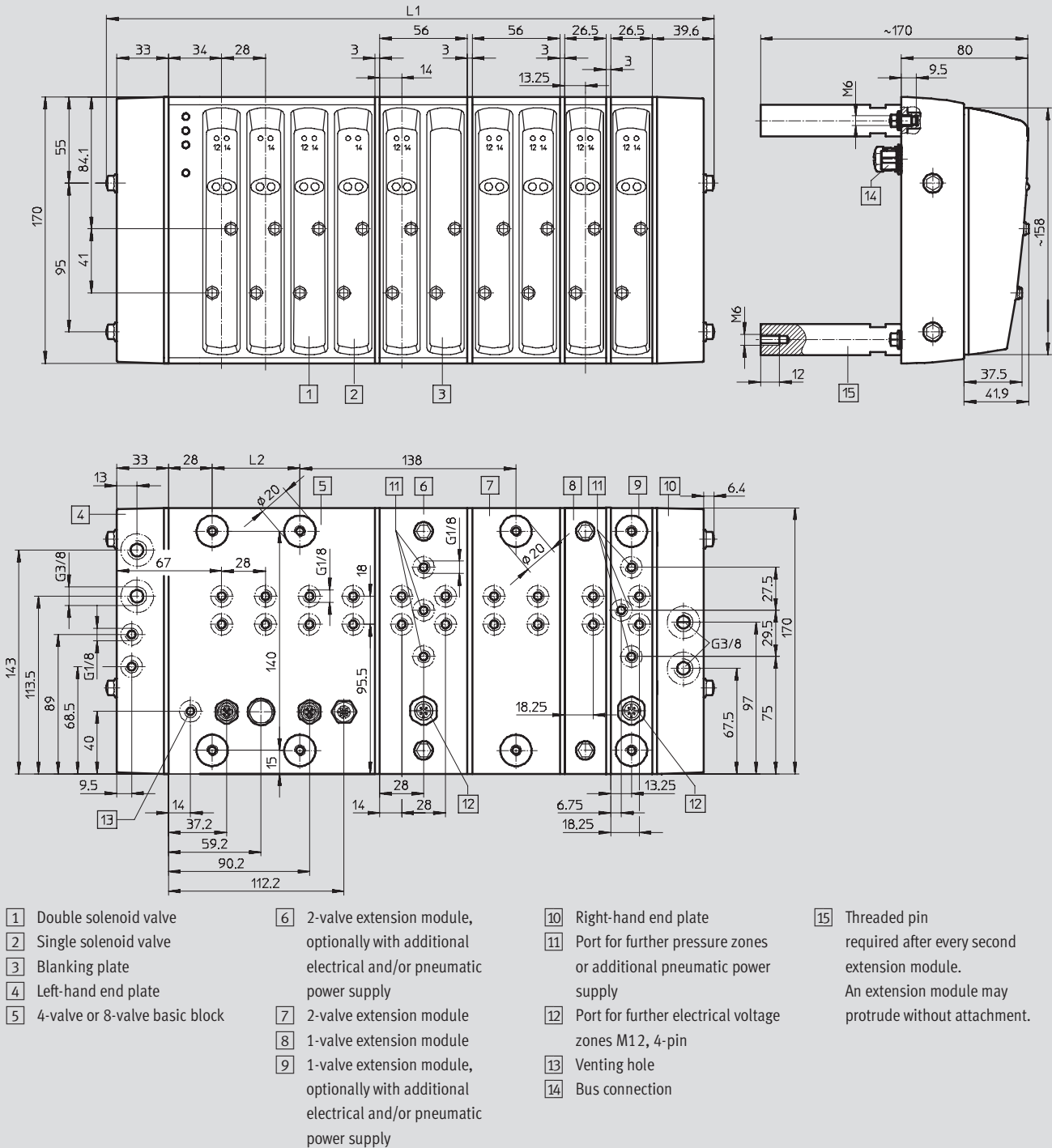

Basic block		Valve positions												
		5	6	7	8	9	10	11	12	13	14	15	16	
4-valve	L1	210.8	240.3	269.8	299.3	328.8	358.3	367.8	417.3	446.8	476.3	505.8	535.3	564.8
	L2	56												
8-valve	L1	322.8				352.3	381.8	411.3	440.8	470.3	499.8	529.3	558.3	
	L2	168												

# Valve terminals type 15 CDVI, Clean Design

Accessories

**FESTO**

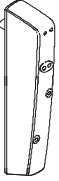
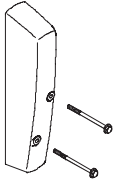
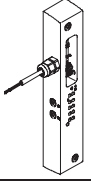
Ordering data				
	Code	Description	Type	Part No.
<b>Individual sub-base valve</b>				
	R	2/2-way single solenoid valve, normally closed, external supply air	CDVI5.0-MT2H-1X2GLS-EXT	556 379
	S	2/2-way single solenoid valve, normally closed, external supply air	CDVI5.0-MT2H-1X2OLS-EXT	556 380
	X	3/2-way valve, normally closed, external supply air	CDVI5.0-MT2H-1X3GLS-EXT	547 013
	W	3/2-way valve, normally open, external supply air	CDVI5.0-MT2H-1X3OLS-EXT	547 014
	K	2x 3/2-way valve, normally closed	CDVI5.0-MT2H-2x3GLS	196 661
	N	2x 3/2-way valve, normally open	CDVI5.0-MT2H-2x3OLS	196 663
	H	2x 3/2-way valve, 1x normally open, 1x normally closed	CDVI5.0-MT2H-3OLS-3GLS	196 665
	M	5/2-way valve, single solenoid	CDVI5.0-MT2H-5LS	196 657
	J	5/2-way valve, double solenoid	CDVI5.0-MT2H-5JS	196 659
	B	5/3-way valve, mid-position closed	CDVI5.0-MT2H-5/3GS	196 651
	E	5/3-way valve, mid-position pressurised	CDVI5.0-MT2H-5/3BS	196 655
	G	5/3-way valve, mid-position exhausted	CDVI5.0-MT2H-5/3ES	196 653
	A	Blanking plate for vacant valve position Valve terminal only	CDVI5.0-A-P-2	193 140
<b>Sub-bases</b>				
	1	Sub-base, individual connection	CDSV5.0-AS-1/8	534 434

# Valve terminals type 15 CDVI, Clean Design

FESTO

Accessories

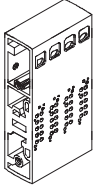
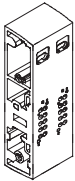
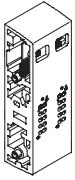







Ordering data				
	Code	Description	Type	Part No.
<b>Basic block</b>				
	4	Basic block with 4 valve positions for multi-pin plug	CDVI5.0-GB4-MP	196 714
		Basic block with 4 valve positions for fieldbus	CDVI5.0-GB4-DN	535 840
	8	Basic block with 8 valve positions for multi-pin plug	CDVI5.0-GB8-MP	196 690
		Basic block with 8 valve positions for fieldbus	CDVI5.0-GB8-DN	535 839
<b>Extension modules for multi-pin plug</b>				
	B1, D1, F1, H1	Extension module for 1 valve position, multi-pin plug, single solenoid	CDVI5.0-EB1-MP-MO	548 422
	B1, D1, F1, H1	Extension module for 1 valve position, multi-pin plug, double solenoid	CDVI5.0-EB1-MP-BI	548 423
	B, D, F, H	Extension module for 2 valve positions, multi-pin plug, single solenoid	CDVI5.0-EB2-MP-MO	548 428
	B, D, F, H	Extension module for 2 valve positions, multi-pin plug, double solenoid	CDVI5.0-EB2-MP-BI	554 369
	P	Extension module for 1 valve position, separate supply and exhaust ports, multi-pin plug, single solenoid	CDVI5.0-EB1X-MP-MO	548 430
	P	Extension module for 1 valve position, separate supply and exhaust ports, multi-pin plug, double solenoid	CDVI5.0-EB1X-MP-BI	548 431
	P	Extension module for 2 valve positions, separate supply and exhaust ports, multi-pin plug, single solenoid	CDVI5.0-EB2X-MP-MO	548 436
	P	Extension module for 2 valve positions, separate supply and exhaust ports, multi-pin plug, double solenoid	CDVI5.0-EB2X-MP-BI	554 370
<b>Extension modules for fieldbus</b>				
	B1, D1, F1, H1	Extension module for 1 valve position, fieldbus, single solenoid	CDVI5.0-EB1-DN-MO	548 424
	B1, D1, F1, H1	Extension module for 1 valve position, fieldbus, double solenoid	CDVI5.0-EB1-DN-BI	548 426
	B, D, F, H	Extension module for 2 valve positions, fieldbus, single solenoid	CDVI5.0-EB2-DN-MO	548 429
	B, D, F, H	Extension module for 2 valve positions, fieldbus, double solenoid	CDVI5.0-EB2-DN-BI	554 371
	V	Extension module for 1 valve position, separate electrical additional supply, fieldbus, single solenoid	CDVI5.0-EB1Z-DN-MO	548 425
	V	Extension module for 1 valve position, separate electrical additional supply, fieldbus, double solenoid	CDVI5.0-EB1Z-DN-BI	548 427
	V	Extension module for 2 valve positions, separate electrical additional supply, fieldbus, single solenoid	CDVI5.0-EB2Z-DN-MO	549 616
	V	Extension module for 2 valve positions, separate electrical additional supply, fieldbus, double solenoid	CDVI5.0-EB2Z-DN-BI	549 619
	P	Extension module for 1 valve position, separate supply and exhaust ports, fieldbus, single solenoid	CDVI5.0-EB1X-DN-MO	548 432
	P	Extension module for 1 valve position, separate supply and exhaust ports, fieldbus, double solenoid	CDVI5.0-EB1X-DN-BI	548 434
	P	Extension module for 2 valve positions, separate supply and exhaust ports, fieldbus, single solenoid	CDVI5.0-EB2X-DN-MO	548 437
	P	Extension module for 2 valve positions, separate supply and exhaust ports, fieldbus, double solenoid	CDVI5.0-EB2X-DN-BI	554 372
	C	Extension module with separate electrical additional supply as well as separate supply and exhaust ports, fieldbus, single solenoid	CDVI5.0-EB1XZ-DN-MO	548 433
	C	Extension module with separate electrical additional supply as well as separate supply and exhaust ports, fieldbus, double solenoid	CDVI5.0-EB1XZ-DN-BI	548 435
	C	Extension module with separate electrical additional supply as well as separate supply and exhaust ports, fieldbus, single solenoid	CDVI5.0-EB2XZ-DN-MO	549 617
	C	Extension module with separate electrical additional supply as well as separate supply and exhaust ports, fieldbus, double solenoid	CDVI5.0-EB2XZ-DN-BI	548 438



# Valve terminals type 15 CDVI, Clean Design

FESTO







Accessories

Ordering data					
	Code	Description	Type	Part No.	
<b>Separator plates</b>					
	B	No duct separation	CDVI5.0-DZ	196 700	
	D	Duct 1 separated Ducts 3 and 5 open	CDVI5.0-DZP	196 702	
	F	Duct 1 open Ducts 3 and 5 separated	CDVI5.0-DZR	196 704	
	H	Ducts 1, 3 and 5 separated	CDVI5.0-DZPR	196 706	
<b>Left-hand end plate</b>					
	K05	Electrical multi-pin plug, cable length 5 m	CDVI5.0-EPL-MP-K05	196 692	
	K10	Electrical multi-pin plug, cable length 10 m	CDVI5.0-EPL-MP-K10	196 694	
	F11	DeviceNet fieldbus connection	CDVI5.0-EPL-DN-LI	535 838	
<b>Right-hand end plate</b>					
	-	Internal pilot air supply	CDVI5.0-EPR	196 696	
	-	External pilot air supply	CDVI5.0-EPR-S	196 698	
<b>Bus connection</b>					
	-	DeviceNet plug socket/Micro Style connection, M12, 5-pin, straight socket (A-coded), IP65, Pg9	FBSD-GD-9-5POL	18 324	
	-	DeviceNet plug/power supply/Micro Style connection, M12, 5-pin, straight plug (A-coded), IP65, Pg9	FBS-M12-5GS-PG9	175 380	
<b>Valve terminal connection</b>					
	-	Connecting cable WS-WD, angled plug-angled socket	0.25 m	KVI-CP-3-WS-WD-0,25	540 327
			0.5 m	KVI-CP-3-WS-WD-0,5	540 328
			2 m	KVI-CP-3-WS-WD-2	540 329
			5 m	KVI-CP-3-WS-WD-5	540 330
			8 m	KVI-CP-3-WS-WD-8	540 331
	-	Connecting cable GS-GD, straight plug-straight socket	2 m	KVI-CP-3-GS-GD-2	540 332
			5 m	KVI-CP-3-GS-GD-5	540 333
			8 m	KVI-CP-3-GS-GD-8	540 334
<b>Input and output modules</b>					
	-	Input and output modules, CPI system → Internet: ctec			

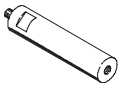
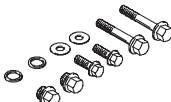
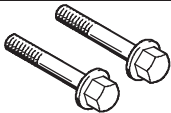
# Valve terminals type 15 CDVI, Clean Design

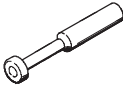
FESTO

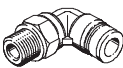
Accessories

Ordering data					
	Code	Description	Type	Part No.	
<b>Mounting attachments</b>					
	Y	Spacer bolt (2 pieces)	CDVI5.0-STB	196 718	
	-	Mounting kit	CDSV5.0	534 436	
	-	Screw kit for attaching the extension modules to the basic block (2 pieces)	for 1 valve position	CDVI5.0-ZA-EB1	548 442
			for 2 valve positions	CDVI5.0-ZA-EB2	548 443
			for 3 valve positions	CDVI5.0-ZA-EB3	548 444
			for 4 valve positions	CDVI5.0-ZA-EB4	548 445
			for 5 valve positions	CDVI5.0-ZA-EB5	548 446
			for 6 valve positions	CDVI5.0-ZA-EB6	548 447
			for 7 valve positions	CDVI5.0-ZA-EB7	548 448
			for 8 valve positions	CDVI5.0-ZA-EB8	548 449
<b>Blanking plug</b>					
	-	Blanking plug	G $\frac{3}{8}$ for end plates	CDVI-5.0-B-G $\frac{3}{8}$	196 712
	-		G $\frac{1}{8}$ for end plates	CDVI-5.0-B-G $\frac{1}{8}$	196 720
	-		for spacer bolt thread	CDVI5.0-B-M6	532 476
<b>Plug</b>					
	-	Blanking plug	for tubing O.D. 6 mm	QSC-6H	153 268
	-		for tubing O.D. 8 mm	QSC-8H	153 269
	-		for tubing O.D. 10 mm	QSC-10H	153 270
	-		for tubing O.D. 12 mm	QSC-12H	153 271
<b>Push-in fittings</b>					
	B	Push-in fitting	for tubing O.D. 6 mm	QS-F-G $\frac{1}{8}$ -6	193 409
	A		for tubing O.D. 8 mm	QS-F-G $\frac{1}{8}$ -8	193 410
	-		for tubing O.D. 12 mm	QS-F-G $\frac{3}{8}$ -12	197 487
	D	Push-in L-fitting	for tubing O.D. 6 mm	QSL-F-G $\frac{1}{8}$ -6	193 419
	C		for tubing O.D. 8 mm	QSL-F-G $\frac{1}{8}$ -8	193 420
	-		for tubing O.D. 12 mm	QSL-F-G $\frac{3}{8}$ -12	197 486
<b>Manual</b>					
	D	Pneumatic components – CDVI	German	P.BE-CDVI-DE	197 361
	E		English	P.BE-CDVI-EN	197 363
	I		Italian	P.BE-CDVI-IT	197 369
	S		Spanish	P.BE-CDVI-ES	197 367
	V		Swedish	P.BE-CDVI-SV	197 371
	D		Electrical components – CDVI-DN	German	P.BE-CDVI-DN-DE
	E	English		P.BE-CDVI-DN-EN	539 045
	I	Italian		P.BE-CDVI-DN-IT	539 048
	S	Spanish		P.BE-CDVI-DN-ES	539 046
	V	Swedish		P.BE-CDVI-DN-SV	539 049