

Stopper cylinders STA/STAF



Stopper cylinders STA/STAF

Key features

At a glance

- Single-acting or double-acting
- Versions
 - Trunnion
 - Roller
 - Toggle lever
- Direct mounting of solenoid valves on flange plate
- Fast and simple set-up of conveyor lines
- Workpiece carriers, pallets and packages weighing up to 150 kg can be safely stopped
- Gentle stopping without impact vibrations or noise with toggle lever version
- Simple actuation via valve terminal (e.g. in combination with other cylinders at an assembly station)
- Flanged solenoid valve permits fast actuation even over long distances and with individual stopper cylinders
- Space-saving sensing via integrated proximity sensors

Trunnion version



Roller version



Toggle lever version



Mounting options

Through-hole mounting

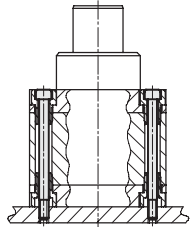

Direct mounting

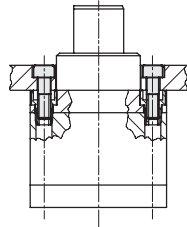

Flange mounting

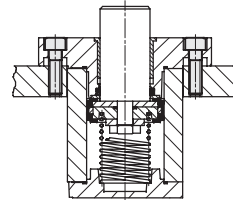

Application options and versions

For heavy masses

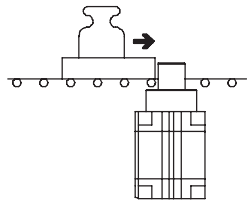

Safety

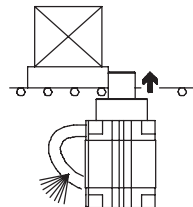

By means of spring return of the piston rod in the event of pressure failure.

Highly effective, low noise level

Toggle lever version with integrated shock absorber facilitates precise and gentle stopping of the workpiece carrier.

-  - Type discontinued, STAF-...-K, piston- \varnothing 50, 80
Available up until 2009

Stopper cylinders STA/STAF

Product range overview

FESTO

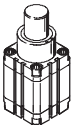
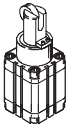
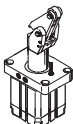
Function	Version	Type	Piston \varnothing [mm]	Stroke [mm]	Type of mounting		Cushioning P	Position sensing A	→ Page/Internet	
					direct	via flange				
Single- or double- acting	Trunnion version									
		STA-...-P-A STAF-...-P-A	20	15	■	-	■	■	4	
			32	20	■	■	■	■		
			50	30	■	■	■	■		
	Roller version									
		STA-...-P-A-R STAF-...-P-A-R	20	15	■	-	■	■	10	
			32	20	■	■	■	■		
			50	30	■	■	■	■		
			80	30, 40	-	■	■	■		
	Toggle lever version									
		STAF-...-P-A-K	32	20	-	■	■	■	20	
			50	30	-	■	■	■		
80			40	-	■	■	■			

Stopper cylinders STA/STAF, trunnion

Functional sequence and type codes

Functional sequence

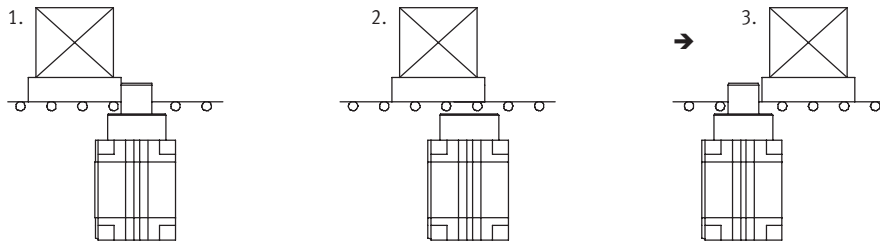

1. Sudden braking of the workpiece carrier via the piston rod.
2. The workpiece carrier is released by activating the cylinder. The control system must hold the piston down until the workpiece carrier has passed the stopper cylinder.
3. The piston rod then advances by means of spring force or compressed air. The next workpiece carrier can then be stopped.

Type codes

		STA	-	20	-	15	-	P	-	A	
Type											
Single-acting or double-acting											
STA	Stopper cylinder										
STAF	Stopper cylinder with flange mounting										
Piston Ø [mm]											
Stroke [mm]											
Cushioning											
P	Flexible cushioning rings/pads at both ends										
Position sensing											
A	Via proximity sensor										
Version											
	Trunnion version										

Stopper cylinders STA/STAF, trunnion

Peripherals overview

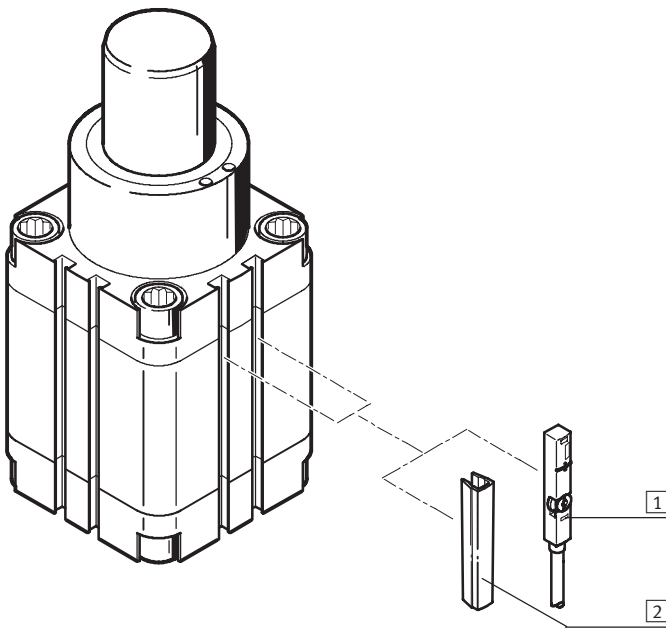

Accessories		
	Brief description	→ Page/Internet
1	Proximity sensor SME/SMT-8	30
2	Slot cover ABP	30

Stopper cylinders STA/STAF, trunnion

Technical data

FESTO

Function



⌀ - Diameter
20 ... 50 mm

l - Stroke length
15 ... 30 mm

www.festo.com

Note

Contact with liquids must be avoided during use.



General technical data				
Piston Ø		20	32	50
Pneumatic connection	STA	M5	G $\frac{1}{8}$	G $\frac{1}{8}$
	STAF	-	M5	G $\frac{1}{8}$
Stroke	[mm]	15	20	30
Piston rod Ø	[mm]	12	20	32
Operating pressure	[bar]	10		
Operating medium	Filtered compressed air, lubricated or unlubricated			
Constructional design	Piston cylinder with spring return			
Cushioning	Flexible cushioning rings/pads at both ends			
Position sensing	Via proximity sensor			
Type of mounting	Via through-holes			
	Via female thread			
Mounting position	Any			
Mode of operation	Single-acting or double-acting			
Protection against rotation	None			
Ambient temperature ¹⁾	[°C]	+5 ... +60		

1) Note operating range of proximity sensors.

Note: This product conforms with the ISO 1179-1 standard and the ISO 228-1 standard.

Forces [N]			
Piston Ø	20	32	50
Permissible impact force on the advanced piston rod	260	1,000	2,900
Spring force	13 ... 18	20 ... 42	43 ... 60

Under "impact force" we understand the maximum of a force-time curve during impact/braking of the moveable mass. It is effective vertical to the movement axis of the piston rod. If one regards the elastic components as linear springs, the permitted impact energy can be calculated from the

permitted impact force. This serves for selecting the correct stopper.

The stopper must not switch under this force. Depending on the mass to be stopped, it may be advisable to provide an elastic buffer in order to cushion the impact, to reduce noise and to optimize the impact energy.

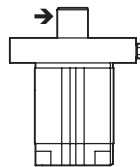

→ = Direction of impact force

Stopper cylinders STA/STAF, trunnion

Technical data

Permissible mass m as a function of the conveyor speed v

The values in the graph opposite are based on the assumption that the workpiece carrier is fitted with a flexible buffer with a deformation path of 1 mm.

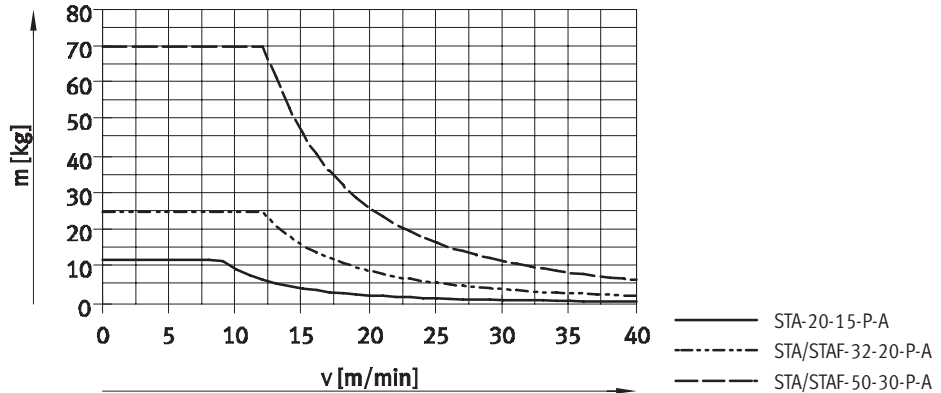

Permissible transverse force F_Q during the switching operation as a function of the pressure p

Under "permitted lateral force" during the switching procedure, we understand the force which still exists vertical to the direction of movement of the piston rod after the impact or braking procedure, e.g. by bands still running or the slope power take-off force of an inclined rolling surface. The force is effective statically. The stopper must not switch under this force. In order that the functioning of the cylinder can be guaranteed, a certain minimum pressure must be applied.

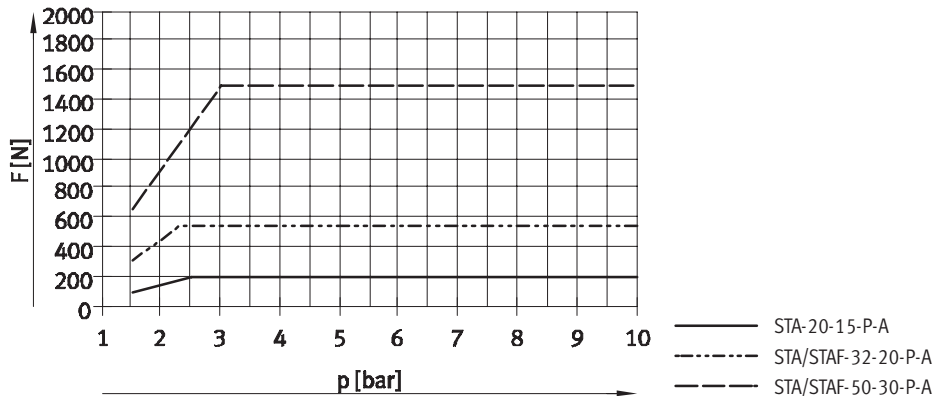

Note
Selection aid → 16

Materials

Sectional view

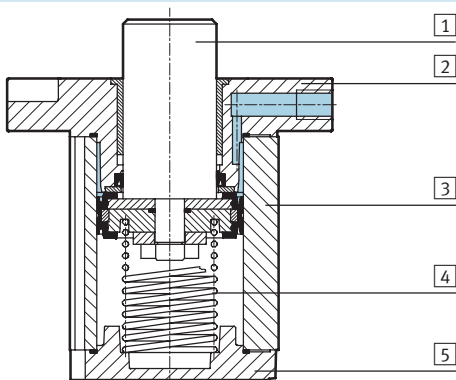

Stopper cylinder		
1	Piston rod	Stainless steel
2	Flange	Die-cast aluminium
3	Cylinder barrel	Anodised aluminium
4	Springs	Spring steel
5	End cap	Anodised aluminium
-	Seals	Polyurethane
-	Note on materials	Free of copper, PTFE and silicone

Stopper cylinders STA/STAF, trunnion

Technical data

FESTO

Dimensions

Download CAD data → www.festo.com

Direct mounting

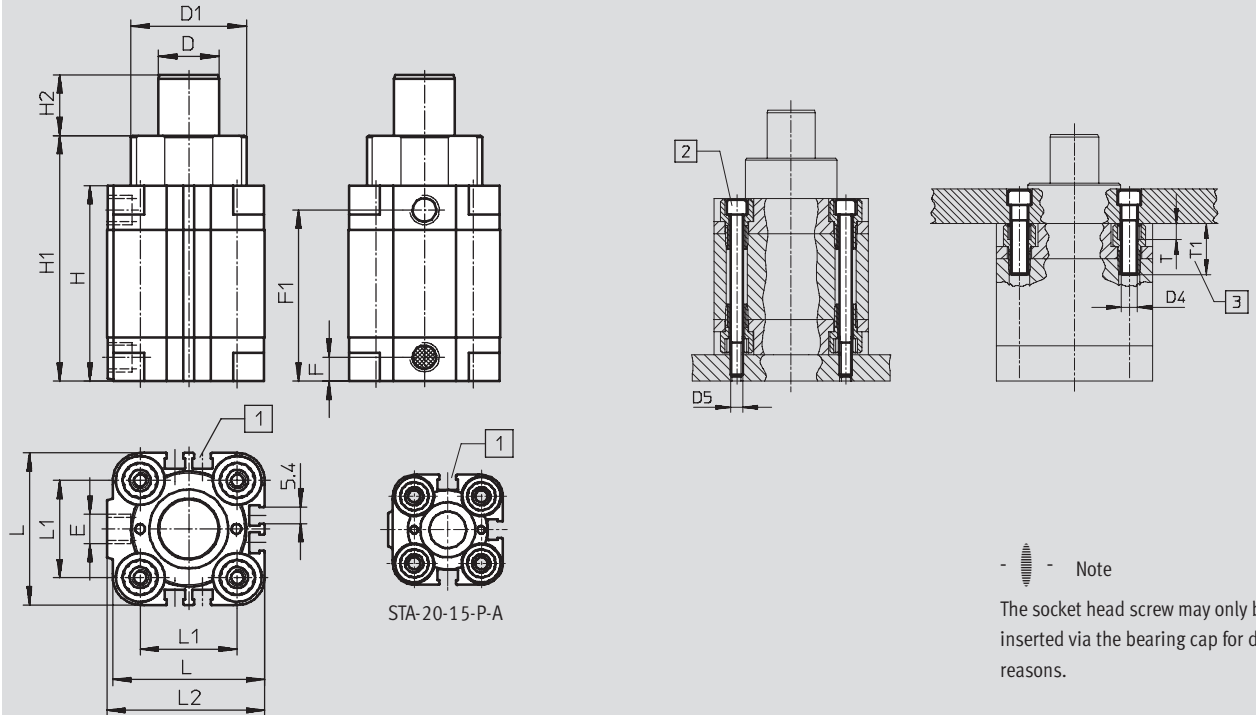

STA-20-15-P-A

1 Slot for proximity sensor
SME/SMT-8

2 Socket head screw to DIN 912,
screwed through

3 Recommended minimum
screw-in depth

Note
The socket head screw may only be
inserted via the bearing cap for design
reasons.

∅	Stroke	D	D1	D4	D5	E	F	F1	H	H1	H2	L	L1	L2	T	T1
[mm]	[mm]	∅	∅													
20	15	12	26	M5	M4	M5	8	45	53	64.5	15	36	22	37.5	4	18
32	20	20	38	M6	M5	G $\frac{3}{8}$	8	56.5	64.5	80.5	20	50	32	52	5	20
50	30	32	53	M8	M6	G $\frac{3}{8}$	8	67.5	75.5	99.5	30	68	50	71	6	20

Note: This product conforms with the ISO 1179-1 standard and the ISO 228-1 standard.

Stopper cylinders STA/STAF, trunnion

Technical data

FESTO

Dimensions

Download CAD data → www.festo.com

Flange mounting

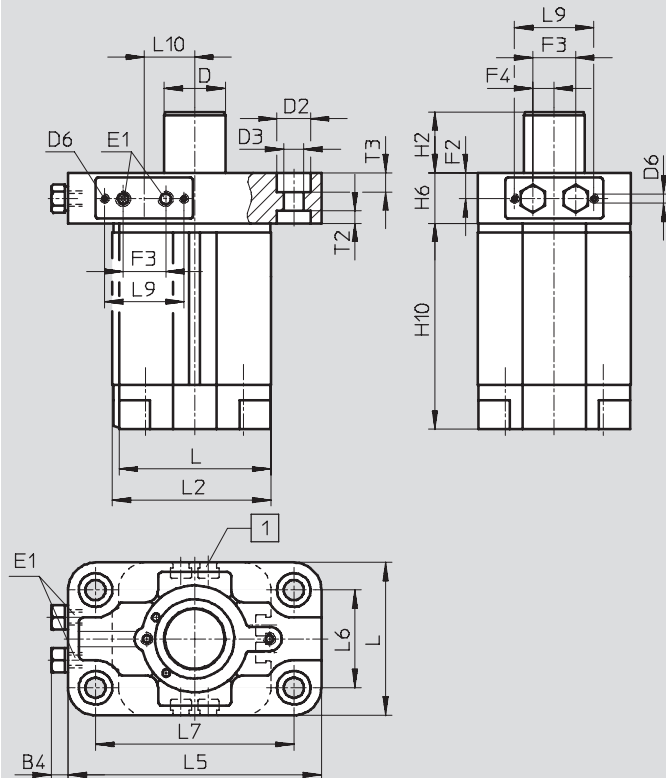

1 Slot for proximity sensor
SME/SMT-8

∅	Stroke	B4	D	D2	D3	D6	E1	F2	F3	F4	H2
[mm]	[mm]		∅	∅	∅						
32	20	4.5	20	11	6.6	M3	M5	8.5	14	7	20
50	30	4.5	32	15	9	M4	G $\frac{1}{8}$	9	17	8	30

∅	Stroke	H6	H10	L	L2	L5	L6	L7	L9	L10	T2	T2
[mm]	[mm]											
32	20	16.5	67.5	50	52	83	32	65	26	16.5	4	6.2
50	30	18	85	68	71	111	45	90	36	7	5	5

• Note: This product conforms with the ISO 1179-1 standard and the ISO 228-1 standard.

Ordering data

Piston ∅ [mm]	Stroke [mm]	Direct mounting		Flange mounting	
		Part No.	Type	Part No.	Type
20	15	164 887	STA-20-15-P-A	-	-
32	20	164 888	STA-32-20-P-A	164 890	STAF-32-20-P-A
50	30	164 889	STA-50-30-P-A	164 891	STAF-50-30-P-A

Stopper cylinders STA/STAF, roller

Functional sequence and type codes

Functional sequence

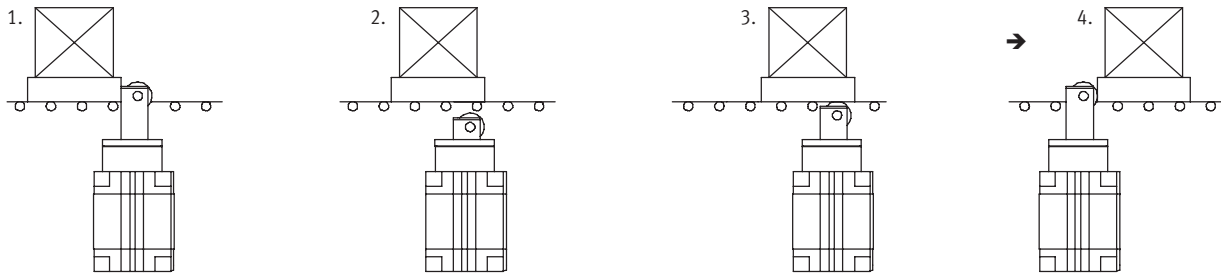

1. Sudden braking of the workpiece carrier via the piston rod.
2. The workpiece carrier is released by activating the cylinder.
3. The piston rod then advances by means of spring force or compressed air until the roller makes contact with the workpiece carrier. The workpiece carrier continues to move forward.
4. After the workpiece carrier has passed, the piston rod advances to the end position. The next workpiece carrier can then be stopped.

Type codes

		STA	-	20	-	15	-	P	-	A	-	R
Type												
Single-acting or double-acting												
STA	Stopper cylinder											
STAF	Stopper cylinder with flange mounting											
Piston Ø [mm]												
Stroke [mm]												
Cushioning												
P	Flexible cushioning rings/pads at both ends											
Position sensing												
A	Via proximity sensor											
Version												
R	Roller version											

Stopper cylinders STA/STAF, roller

Peripherals overview

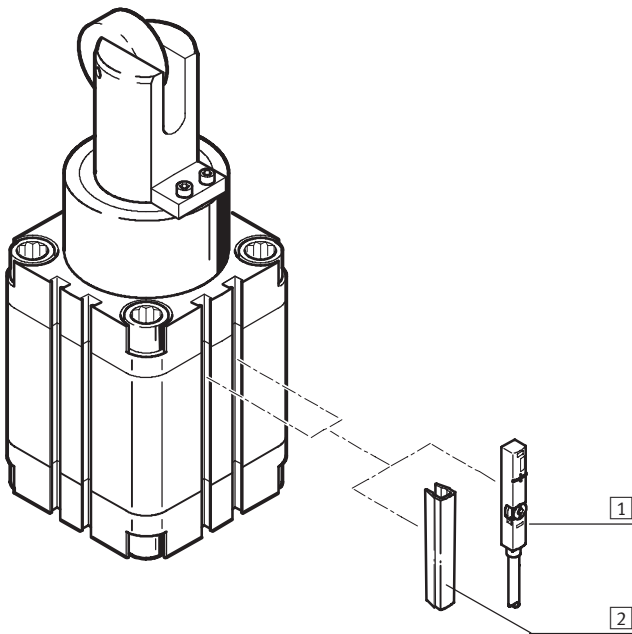

Accessories		
	Brief description	→ Page/Internet
1	Proximity sensor SME/SMT-8	Can be integrated in the cylinder profile barrel 30
2	Slot cover ABP	For protecting against ingress of dirt 30

Stopper cylinders STA/STAF, roller

Technical data

FESTO

Function



⊘ - Diameter
20 ... 80 mm

┆ - Stroke length
15 ... 40 mm

www.festo.com

Note

Contact with liquids must be avoided during use.



General technical data		20	32	50	80
Piston ⊘		20	32	50	80
Pneumatic connection	STA	M5	G $\frac{1}{8}$	G $\frac{1}{8}$	-
	STAF	-	M5	G $\frac{1}{8}$	G $\frac{1}{8}$
Stroke	[mm]	15	20	30	30/40
Piston rod ⊘	[mm]	12	20	32	50
Operating pressure	[bar]	10			
Operating medium		Filtered compressed air, lubricated or unlubricated			
Constructional design		Piston cylinder with spring return			
Cushioning		Flexible cushioning rings/pads at both ends			
Position sensing		Via proximity sensor			
Type of mounting		Via through-holes			
		Via female thread			
Mounting position		Any			
Mode of operation		Single-acting or double-acting			
Protection against rotation		Flat-sided piston rod			
Ambient temperature ¹⁾	[°C]	+5 ... +60			

1) Note operating range of proximity sensors.

Note: This product conforms with the ISO 1179-1 standard and the ISO 228-1 standard.

Forces [N]		20	32	50	80
Piston ⊘		20	32	50	80
Stroke		15	20	30	30 40
Permissible impact force on the advanced piston rod		170	830	2,300	14,600 13,300
Spring force		13 ... 18	20 ... 42	43 ... 60	79 ... 115 101 ... 170

Under "impact force" we understand the maximum of a force-time curve during impact/braking of the moveable mass. It is effective vertical to the movement axis of the piston rod. If one regards the elastic components as linear springs, the permitted impact energy can be calculated from the

permitted impact force. This serves for selecting the correct stopper. The stopper must not switch under this force. Depending on the mass to be stopped, it may be advisable to provide an elastic buffer in order to cushion the impact, to reduce noise and to optimize the impact energy.

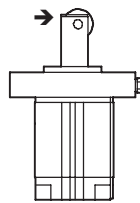

→ = Direction of impact force

Stopper cylinders STA/STAF, roller

Technical data

Permissible mass m as a function of the conveyor speed v

The values in the graph opposite are based on the assumption that the workpiece carrier is fitted with a flexible buffer with a deformation path of 1 mm.

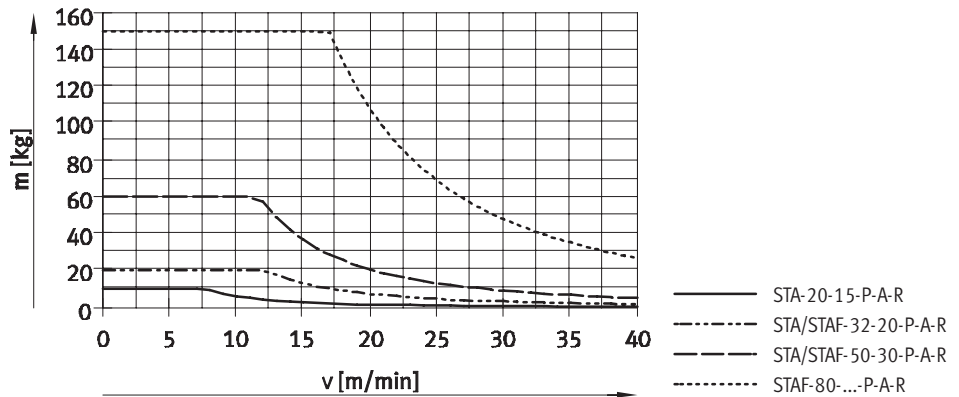

Permissible transverse force F_Q during the switching operation as a function of the pressure p

Under "permitted lateral force" during the switching procedure, we understand the force which still exists vertical to the direction of movement of the piston rod after the impact or braking procedure, e.g. by bands still running or the slope power take-off force of an inclined rolling surface. The force is effective statically. The stopper must not switch under this force. In order that the functioning of the cylinder can be guaranteed, a certain minimum pressure must be applied.

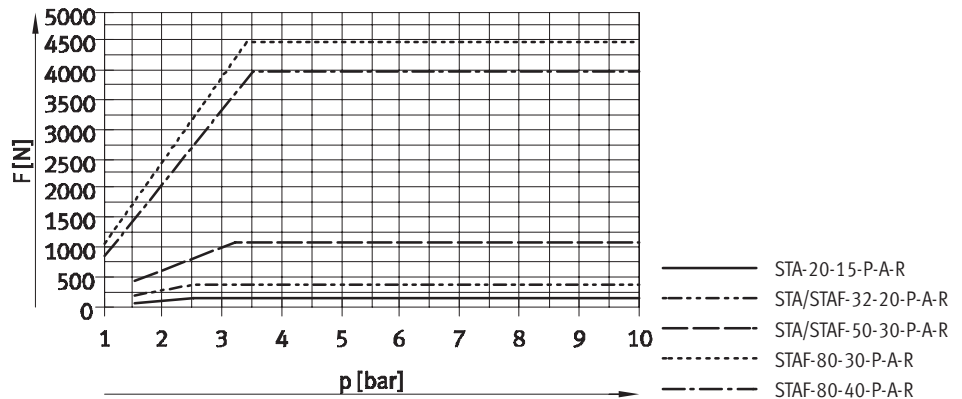

Note
Selection aid → 16

Materials

Sectional view

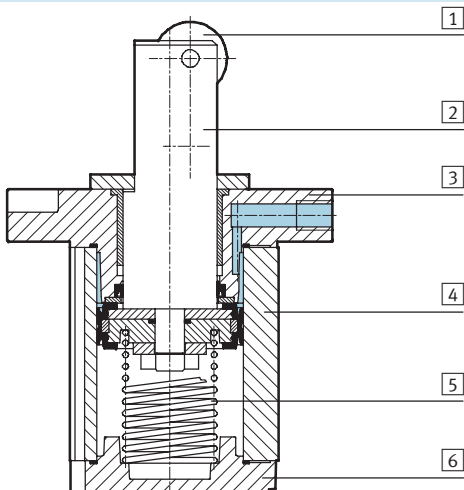

Stopper cylinder		
1	Roller	Steel
2	Piston rod	Stainless steel
3	Flange	Die-cast aluminium
4	Cylinder barrel	Anodised aluminium
5	Springs	Spring steel
6	End cap	Anodised aluminium
-	Seals	Polyurethane
-	Note on materials	Free of copper, PTFE and silicone

Stopper cylinders STA/STAF, roller

Technical data

FESTO

Dimensions

Download CAD data → www.festo.com

Direct mounting

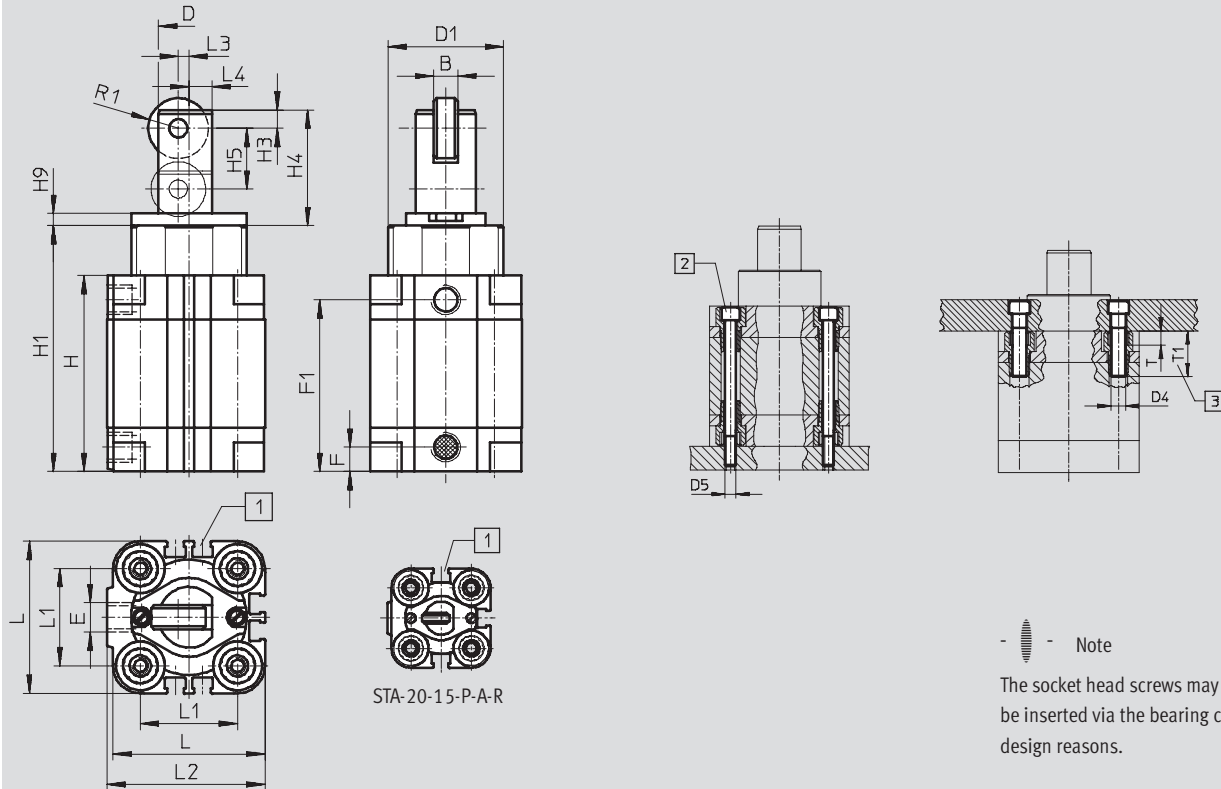

STA-20-15-P-A-R

Note
The socket head screws may only be inserted via the bearing cap for design reasons.

1 Slot for proximity sensor
SME/SMT-8

2 Socket head screw to DIN 912,
screwed through

3 Recommended minimum
screw-in depth

∅	Stroke	B	D	D1	D4	D5	E	F	F1	H	H1	H3
[mm]	[mm]		∅	∅								
20	15	4	12	26	M5	M4	M5	8	45	53	64.5	3
32	20	8	20	38	M6	M5	G $\frac{1}{8}$	8	56.5	64.5	80.5	6
50	30	10	32	53	M8	M6	G $\frac{1}{8}$	8	67.5	75.5	99.5	6

∅	Stroke	H4	H5	H9	L	L1	L2	L3	L4	R1	T	T1
[mm]	[mm]											
20	15	24	15	4	36	22	37.5	2	4.5	5	4	18
32	20	38	20	4	50	32	52	3.5	7.5	9	5	20
50	30	50.5	30	5	68	50	71	7	12	12.5	6	20

Note: This product conforms with the ISO 1179-1 standard and the ISO 228-1 standard.

Stopper cylinders STA/STAF, roller

Technical data

FESTO

Dimensions

Download CAD data → www.festo.com

Flange mounting

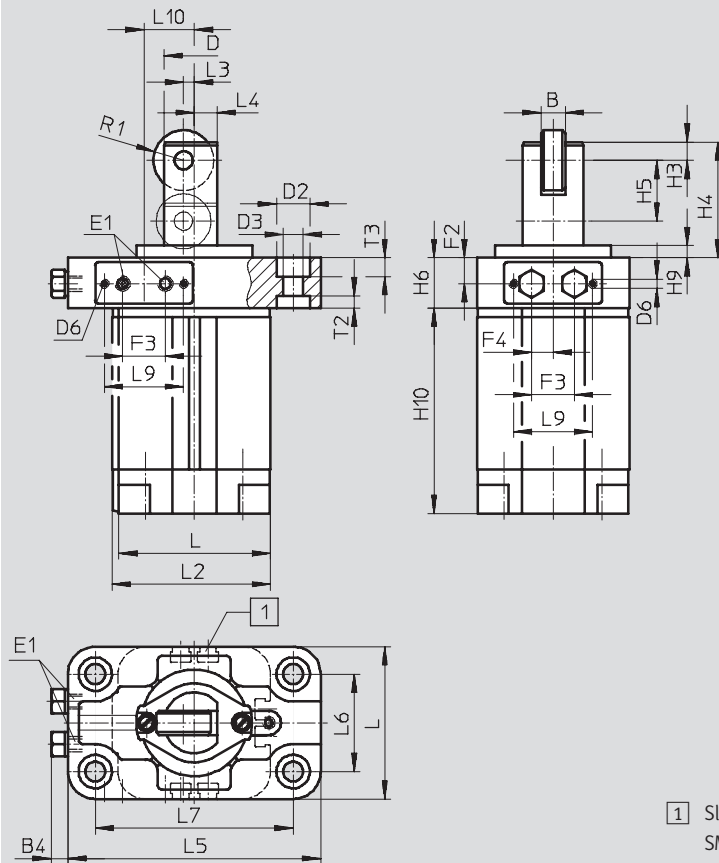

1 Slot for proximity sensor
SME/SMT-8

∅	Stroke	B	B4	D	D2	D3	D6	E1	F2	F3	F4	H3	H4	H5	H6
[mm]	[mm]			∅	∅	∅									
32	20	8	4.5	20	11	6.6	M3	M5	8.5	14	7	6	38	20	16.5
50	30	10	4.5	32	15	9	M4	G1/8	9	17	8	6	50.5	30	18
80	30	18	4.5	50	18	11	M4	G1/8	11	17	4.5	10	63	30	22
	40												73	40	

∅	Stroke	H9	H10	L	L2	L3	L4	L5	L6	L7	L9	L10	R1	T2	T3
[mm]	[mm]														
32	20	4	67.5	50	52	3.5	7.5	83	32	65	26	16.5	9	4	6.2
50	30	5	85	68	71	7	12	111	45	90	36	7	12.5	5	5
80	30	8	119	107	111	11	18	160	63	135	36	18.5	18	6	6
	40		129												

• Note: This product conforms with the ISO 1179-1 standard and the ISO 228-1 standard.

Ordering data

Piston ∅ [mm]	Stroke [mm]	Direct mounting		Flange mounting	
		Part No.	Type	Part No.	Type
20	15	164 883	STA-20-15-P-A-R	-	-
32	20	164 884	STA-32-20-P-A-R	164 892	STAF-32-20-P-A-R
50	30	164 885	STA-50-30-P-A-R	164 893	STAF-50-30-P-A-R
80	30	-	-	164 886	STAF-80-30-P-A-R
80	40	-	-	164 894	STAF-80-40-P-A-R

Stopper cylinders STA/STAF

Technical data

Selection aid

Stopping a workpiece carrier

The stopper cylinder is used to brake an individual workpiece carrier.

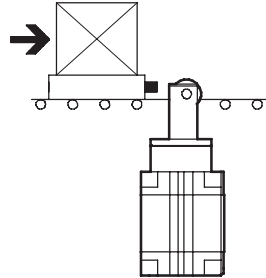

Example

Given:

Friction value $\mu = 0.1$

Delivery speed $v = 10 \text{ m/min}$

Workpiece carrier with workpiece $m = 30 \text{ kg}$

Operating pressure $p = 6 \text{ bar}$

Choice: Stopper cylinder STA...-50-...-R

1. Checking the permissible mass

The maximum permissible mass at a delivery speed of 10 m/min is 60 kg. This means that the total mass of the workpiece carrier and workpiece of 30 kg is permissible.

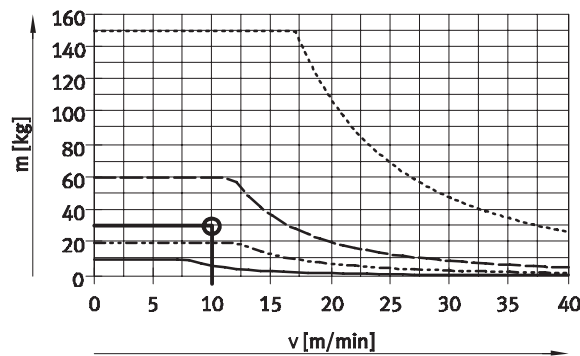

- STA-20-15-P-A-R
- - - STA/STAF-32-20-P-A-R
- STA/STAF-50-30-P-A-R
- - - STA/STAF-80-...-P-A-R

2. Checking the permissible transverse force during the switching operation

Transverse force $F_Q =$ friction force

F_{friction}

$$= \mu \times m \times g$$

$$= 0.1 \times 30 \text{ kg} \times 9.81 \text{ m/s}^2$$

$$= \text{approx. } 30 \text{ N}$$

The maximum permissible transverse force at an operating pressure of 6 bar is 1,100 N.

This means that the transverse force of 30 N is permissible.

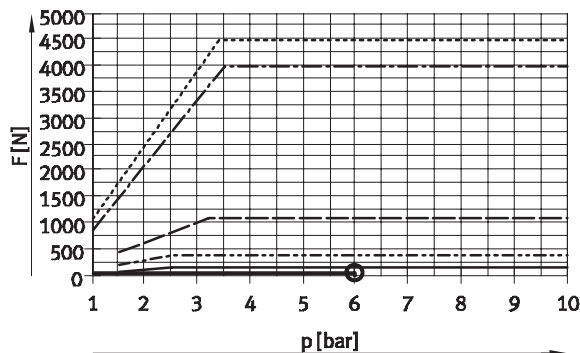

- STA-20-15-P-A-R
- - - STA/STAF-32-20-P-A-R
- STA/STAF-50-30-P-A-R
- - - STA/STAF-80-30-P-A-R
- - - STA/STAF-80-40-P-A-R

Stopper cylinders STA/STAF

Technical data

Selection aid

Stopping or separating several workpiece carriers

The stopper cylinder is used to separate workpiece carriers. Further workpiece carriers accumulate behind carriers already at the stopper cylinder. It is vital that a buffer is mounted between the workpiece carriers (e.g. elastomer elements).

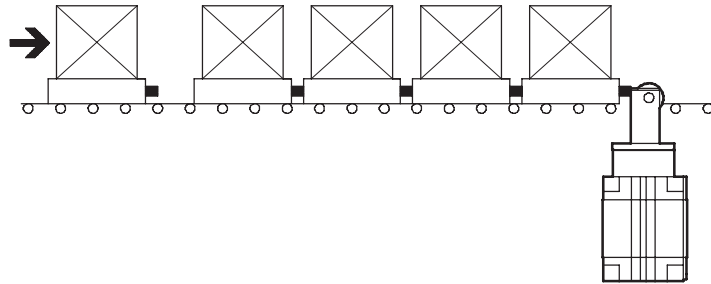

Example

Given:

Friction value $\mu = 0.1$

Delivery speed $v = 10 \text{ m/min}$

Workpiece carrier with workpiece $m = 30 \text{ kg}$

Operating pressure $p = 6 \text{ bar}$

Maximum number of workpiece carriers accumulating simultaneously $n_{\text{Group}} = 1$

Maximum number of all queued workpiece carriers $n_{\text{Queue}} = 5$

Maximum number of all advancing workpiece carriers $n_{\text{Queue-1}} = 4$

Spring travel of the workpiece carrier buffer $s_F = 1 \text{ mm}$

Choice: Stopper cylinder STA...-50-...-R

1. Checking the permissible mass of the first workpiece carrier

The maximum permissible mass at a delivery speed of 10 m/min is 60 kg. This means that the total mass of the workpiece carrier and workpiece of 30 kg is permissible.

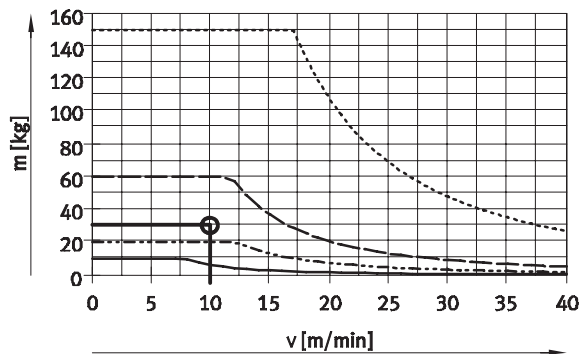

2a. Calculation of the maximum permissible impact force when workpiece carriers accumulate behind a carrier at the stopper cylinder

With the STA...-50, the maximum permissible impact force is 2,300 N. This means that with a total force of 1,000 N, the number of workpiece carriers is permissible.

Impact force calculation:

$$F_{\text{Impact}} = \frac{(n_{\text{Group}} \times m) \times v^2}{s_F} = \frac{(1 \times 30\text{kg}) \times (10\text{m}/60\text{s})^2}{0.001\text{m}} = \text{ca.}850\text{N}$$

Friction force:

$$F_{\text{Friction}} = \mu \times (n_{\text{Queue}} \times m) \times g = 0.1 \times (5 \times 30\text{kg}) \times 9.81\text{m/s}^2 = \text{ca.}150\text{N}$$

Max. total force:

$$F_{\text{Total force}} = F_{\text{Impact}} + F_{\text{Friction}} = 850\text{N} + 150\text{N} = 1000\text{N}$$

Stopper cylinders STA/STAF

Technical data

Selection aid

2b. Checking the permissible transverse force during the switching operation

Transverse force $F_Q =$
friction force $F_{Friction}$
 $F_{Friction} = 150 \text{ N}$

The maximum permissible transverse force at an operating pressure of 6 bar is 1,100 N.

This means that the transverse force of 150 N is permissible.

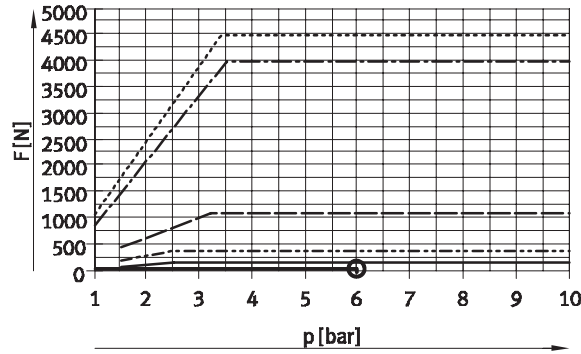

- STA-20-15-P-A-R
- - - STA/STAF-32-20-P-A-R
- STA/STAF-50-30-P-A-R
- - - STA/STAF-80-30-P-A-R
- - - STA/STAF-80-40-P-A-R

3. Separating and advancing the workpiece carriers

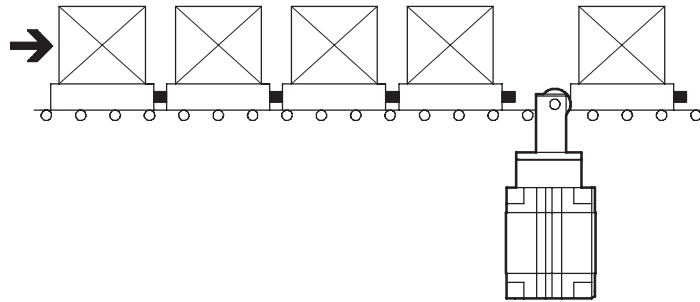

The maximum permissible mass with the STA...-50-...-R at a delivery speed of 10 m/min is 60 kg.

Since the total mass of the four workpiece carriers advancing on the stopper cylinder is 120 kg, the next largest stopper cylinder must be selected for separating.

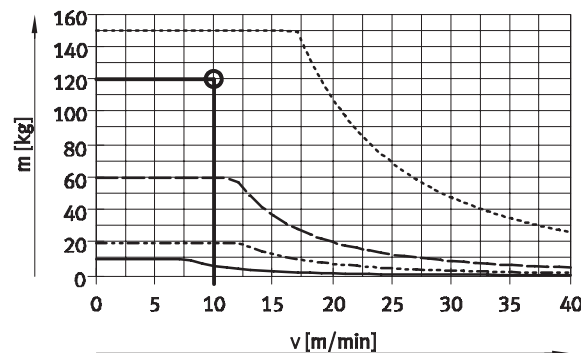

- STA-20-15-P-A-R
- - - STA/STAF-32-20-P-A-R
- STA/STAF-50-30-P-A-R
- - - STA/STAF-80-...-P-A-R

Max. total mass:

$$m_{\text{Total force}} = n_{\text{Queue}-1} \times m = 4 \times 30\text{kg} = 120\text{kg}$$

Result

The stopper cylinder STA...-80-...-R must be selected for separating five workpiece carriers.

Stopper cylinders STA/STAF

Technical data

FESTO

Application example

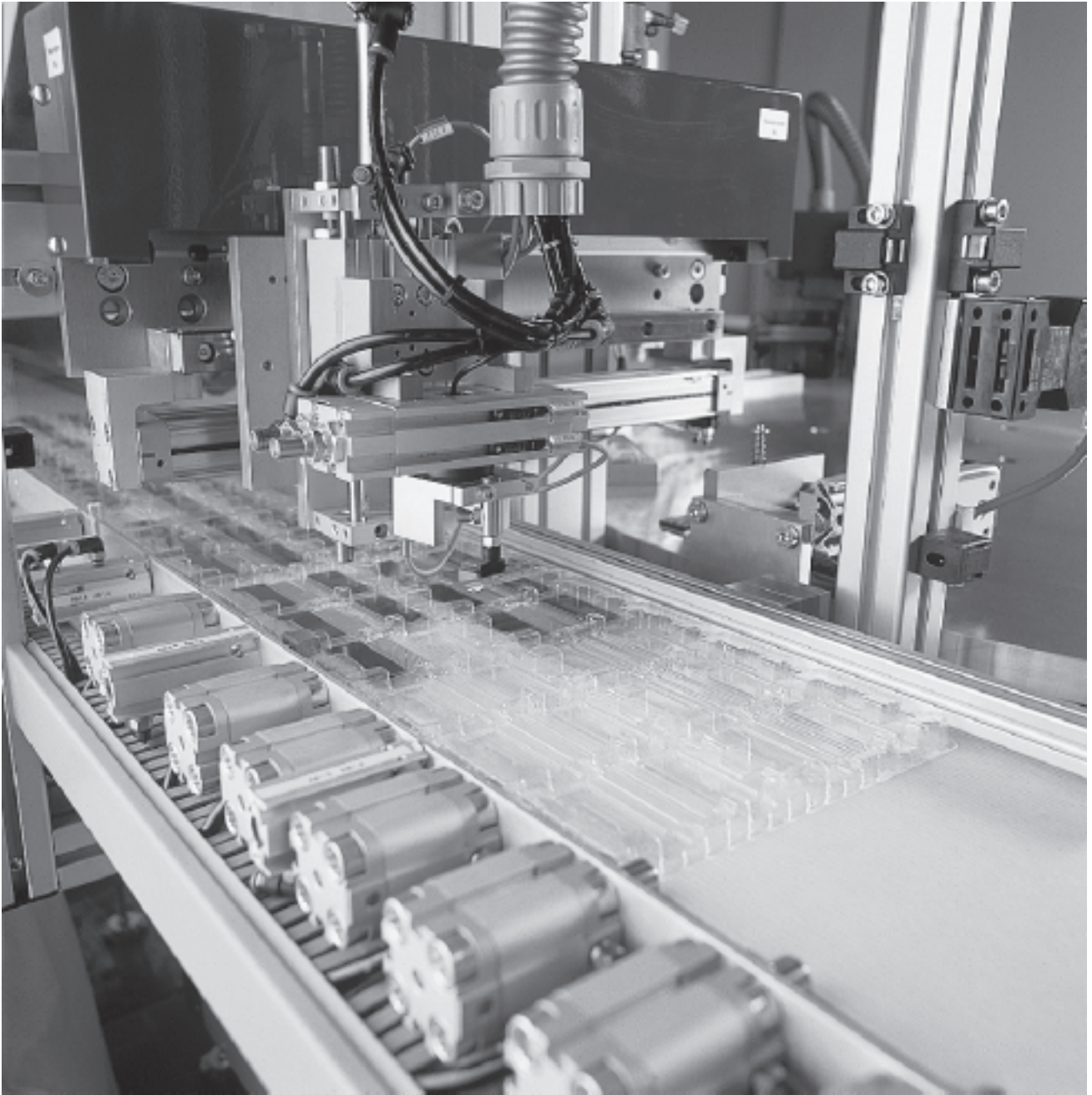

Stopper cylinders STAF, toggle lever

Functional sequence

Functional sequence

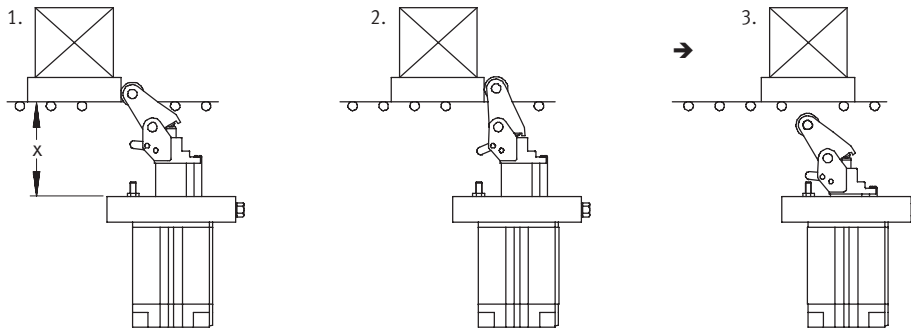

X = STAF-32:	62.8 ... 63.4 mm
STAF-50:	96.5 ... 99.5 mm
STAF-80:	163 ... 166 mm

1. Gentle stopping of heavy masses via a hydraulic shock absorber in the piston rod.
2. The toggle lever is locked into the retracted end position so that the workpiece carrier cannot be pushed back by the shock absorber.
3. The workpiece carrier is released by means of compressed air, and the toggle lever is released simultaneously.

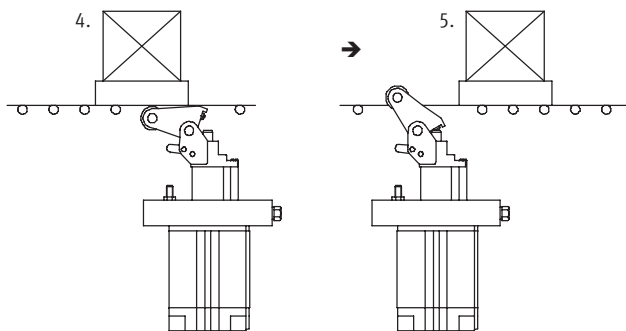

4. The piston is advanced by means of spring force or compressed air. The toggle lever tips back which prevents the workpiece carrier from being pushed up.
5. The toggle lever is raised by means of spring force and stops the next workpiece carrier.

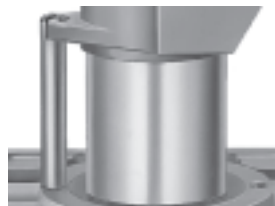

Protection against rotation:
The guide rod always aligns the toggle lever precisely to the approaching workpiece carrier.



Integrated shock absorber: absorbs impact energy and stops the workpiece carrier gently, and with low noise levels.
The impact energy can be adjusted using the regulating screw in the toggle lever.



Detenting roller lever: the workpiece carrier cannot be pushed back by the shock absorber.



Locking mechanism for disabling the stopper function: the workpiece carrier is able to pass the holding point without activating the cylinder.

 Note

Trunnion or roller type stopper cylinders can be mounted in any position.
Stopper cylinders with toggle lever must be mounted in the vertical, upright position.

Stopper cylinders STAF, toggle lever

Key features

Mounting options for solenoid valves and valve functions

An MEH, MEBH, MOEH or MOEBH solenoid valve can be mounted on the stopper cylinder for quick, direct actuation of the cylinder. This type of

actuation is only possible for stopper cylinders with flange mounting. The valve must be mounted on the flange

plate via a valve sub-base ZVA. The position of the piston rod when the solenoid valve is in the normal

position depends upon the valve type and the position of the valve on the cylinder.

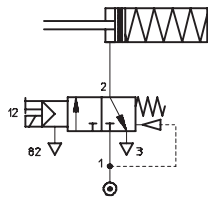
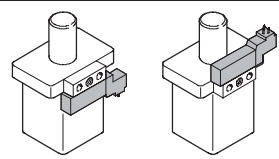
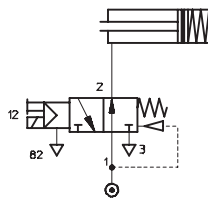
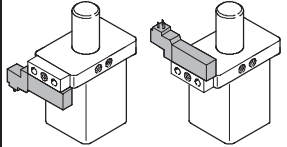
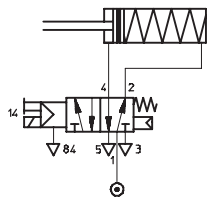
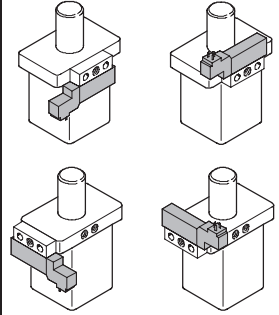
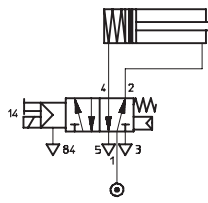
Application	Piston rod in initial position	Required solenoid valve	Type of mounting for the solenoid valve with sub-base ZVA
	Single-acting		
		Normally advanced 173 125 MEH-3/2-5,0-B 172 999 MEBH-3/2-5,0-B	
		Normally retracted 173 429 MOEH-3/2-5,0-B 173 002 MOEBH-3/2-5,0-B	
	Double-acting		
	Normally advanced 173 128 MEH-5/2-5,0-B 173 005 MEBH-5/2-5,0-B		
	Normally retracted 173 128 MEH-5/2-5,0-B 173 005 MEBH-5/2-5,0-B		



Note

Cylinders are always supplied single-acting with spring. If a double-acting stopper cylinder is required, the filter

nipple in the exhaust port must be removed. The exhaust port is then used as a supply port.

Solenoid valves MEH, MEBH
 → Internet: solenoid valve

- 1 - Type discontinued, STAF-...-K, piston- \varnothing 50, 80
Available up until 2009

FESTO

Stopper cylinders STAF, toggle lever

Type codes

		STAF	-	32	-	20	-	P	-	A	-	K
Type												
Single-acting or double-acting												
STAF	Stopper cylinder with flange mounting											
Piston \varnothing [mm]												
Stroke [mm]												
Cushioning												
P	Flexible cushioning rings/pads at both ends											
Position sensing												
A	Via proximity sensor											
Version												
K	Toggle lever version											

-  - Type discontinued, STAF-...-K, piston-Ø 50, 80
Available up until 2009

Stopper cylinders STAF, toggle lever

Peripherals overview

FESTO

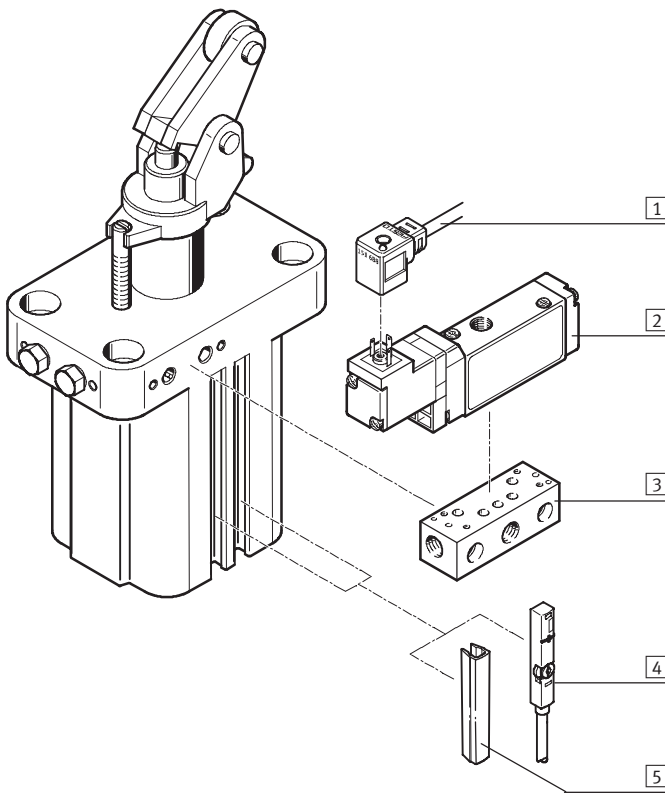

Accessories		
	Brief description	→ Page/Internet
1	Plug socket with cable KMEB	- kmeb
2	3/2-way valve MEBH	For fast and direct actuation of the stopper cylinder mebh
3	Sub-base ZVA	For stopper cylinder with flange 28
4	Proximity sensor SME/SMT-8	Can be integrated in the cylinder profile barrel 30
5	Slot cover ABP	For protecting against ingress of dirt 30

-  - Type discontinued, STAF-...-K, piston- \varnothing 50, 80
Available up until 2009

Stopper cylinders STAF, toggle lever

Technical data

FESTO

Function



- \varnothing - Diameter
32 ... 80 mm

-  - Stroke length
20 ... 40 mm

-  - www.festo.com

-  - Note

Contact with liquids must be avoided during use.



General technical data			
Piston \varnothing	32	50	80
Pneumatic connection	M5	G $\frac{1}{8}$	G $\frac{1}{8}$
Stroke [mm]	20	30	40
Piston rod \varnothing [mm]	20	32	50
Operating pressure [bar]	10		
Operating medium	Filtered compressed air, lubricated or unlubricated		
Constructional design	Piston cylinder with spring return		
Cushioning	Flexible cushioning rings/pads at both ends		
Position sensing	Via proximity sensor		
Type of mounting	Via through-holes		
Mounting position	Vertical, upright		
Mode of operation	Single-acting or double-acting		
Protection against rotation	Guide rod		
Ambient temperature ¹⁾ [°C]	+5 ... +60		

1) Note operating range of proximity sensors.

-  - Note: This product conforms with the ISO 1179-1 standard and the ISO 228-1 standard.

Forces [N]			
Piston \varnothing	32	50	80
Permissible impact force on the rollers of the toggle lever when the piston rod is advanced and the toggle lever is pushed into its end position	480	1,200	6,400
Spring force	20 ... 42	47 ... 64	101 ... 170

Impact force is the basis for the calculation of permissible impact energy. Depending upon the type of load to be stopped, it is advisable to use a flexible buffer to cushion the impact, reduce noise levels and to optimise impact energy.

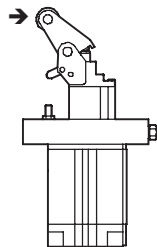

→ = Direction of impact force

Stopper cylinders STAF, toggle lever

Technical data

FESTO

Permissible mass m as a function of the conveyor speed v

STAF-32 with a friction value of $\mu = 0.1$

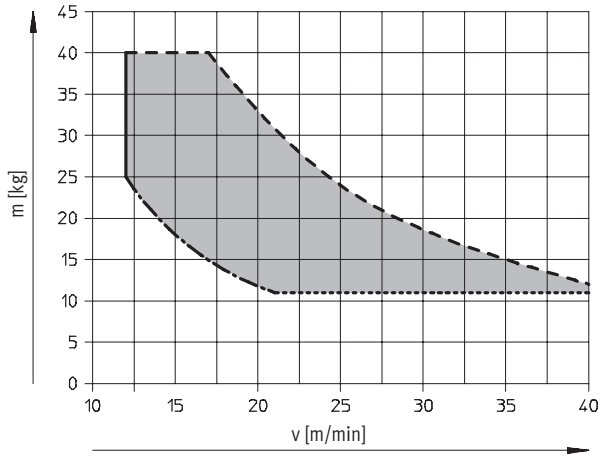



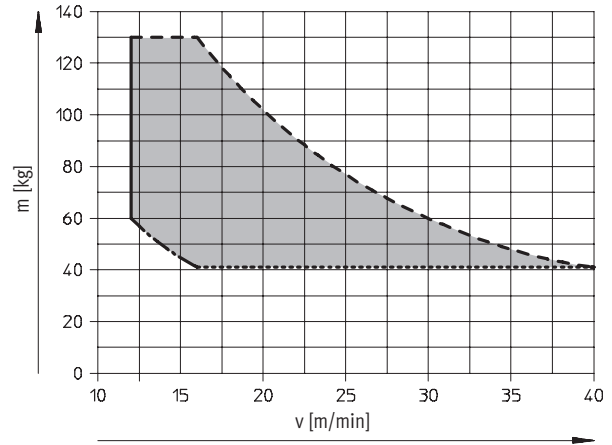

STAF-50 with a friction value of $\mu = 0.1$

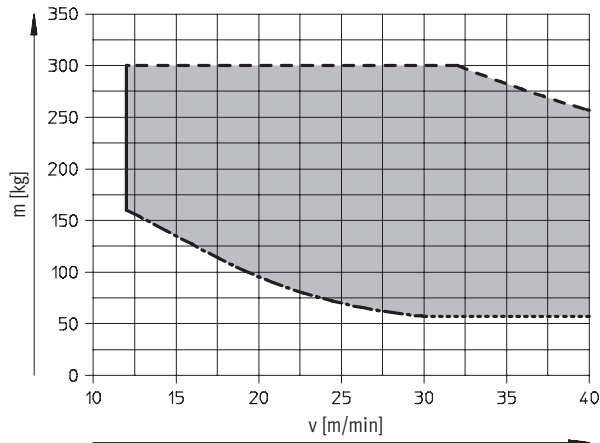

STAF-80 with a friction value of $\mu = 0.1$



-  Operating range
-  Max. workload
-  Recommended minimum workload 1)
-  Required mass 2)

- 1) For optimum operation of the damper
- 2) Required mass for reliable pushing of the toggle lever into the end position with this friction value

Note

The required mass for reliable pushing into the end position is dependent on the friction pairing between the conveyor and conveyed goods, other friction values on request.

Cushioning time is increased for partial loads.
Energy values valid for ambient temperature $T = 20\text{ }^{\circ}\text{C}$

-  - Type discontinued, STAF-...-K, piston- \varnothing 50, 80
Available up until 2009

Stopper cylinders STAF, toggle lever

Technical data

FESTO

Materials

Sectional view

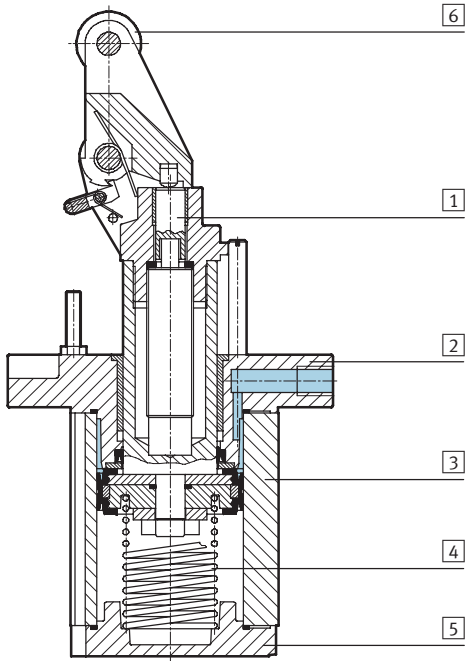

Stopper cylinder

1	Piston rod	Stainless steel
2	Flange	Die-cast aluminium
3	Cylinder barrel	Anodised aluminium
4	Springs	Spring steel
5	End cap	Anodised aluminium
6	Roller	Polyacetate
-	Seals	Polyurethane
-	Note on materials	Free of copper, PTFE and silicone

Minimum distance to the conveyor

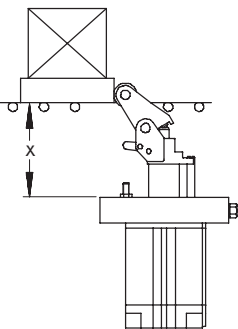

X = STAF-32:	62.8 ... 63.4 mm
STAF-50:	96.5 ... 99.5 mm
STAF-80:	163 ... 166 mm

-  - Type discontinued, STAF-...-K, piston- \varnothing 50, 80
Available up until 2009

Stopper cylinders STAF, toggle lever

Technical data

FESTO

Dimensions

Download CAD data → www.festo.com

Flange mounting

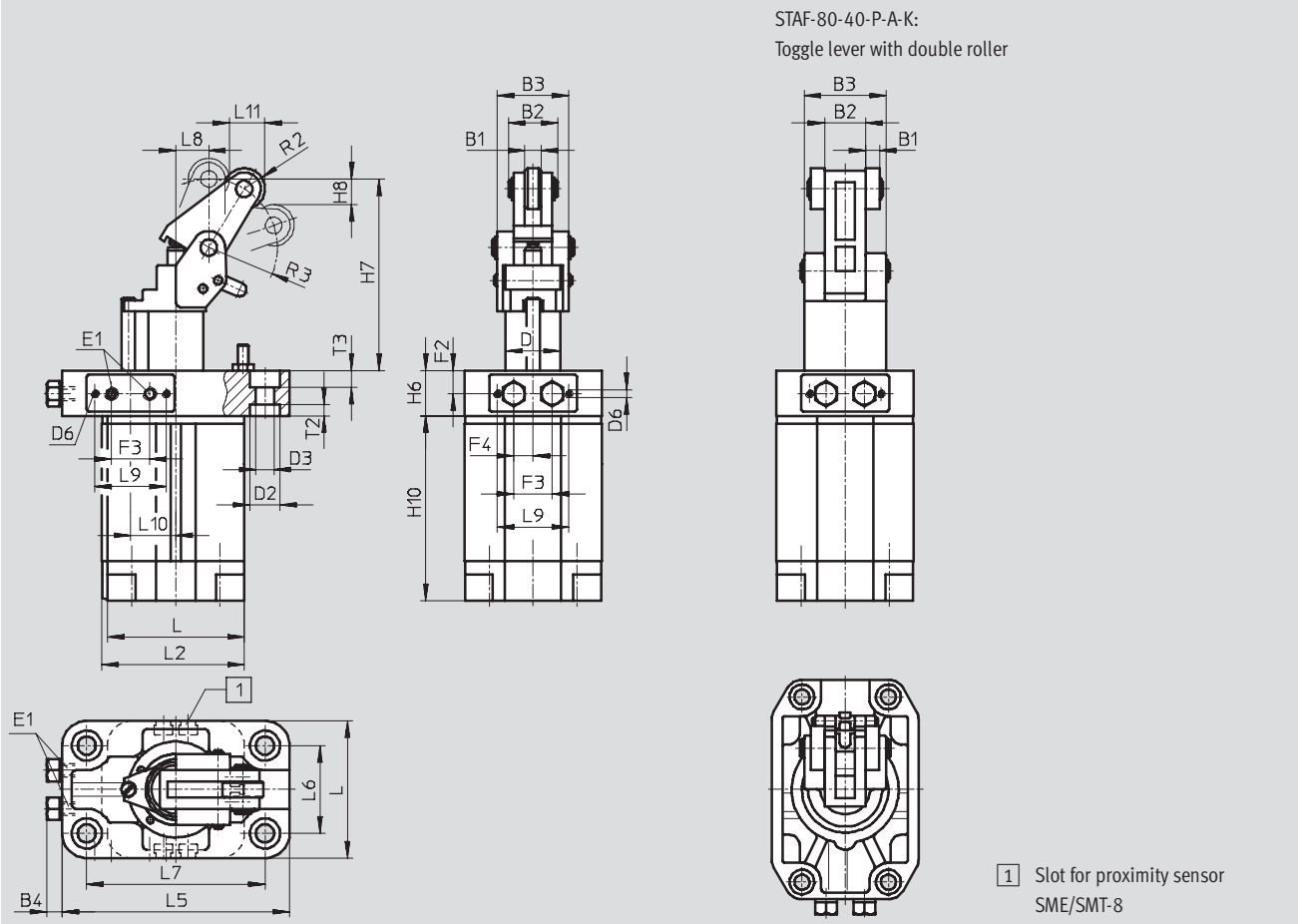

\varnothing	Stroke	B1	B2	B3	B4	D	D2	D3	D6	E1	F2	F3	F4	H6	H7	H8
[mm]	[mm]					\varnothing	\varnothing	\varnothing								
32	20	6	18	26	4.5	20	11	6.6	M3	M5	8.5	14	7	16.5	70	9.5
50	30	10	27	38	4.5	32	15	9	M4	G $\frac{1}{8}$	9	17	8	18	106	12
80	40	10	30	60	4.5	50	18	11	M4	G $\frac{1}{8}$	11	17	4.5	22	182.5	23

\varnothing	Stroke	H10	L	L2	L5	L6	L7	L8	L9	L10	L11	R2	R3	T2	T3
[mm]	[mm]														
32	20	67.5	50	52	83	32	65	12	26	16.5	13	7.5	25	4	6.2
50	30	85	68	71	111	45	90	21	36	7	17	11	39	5	5
80	40	129	107	111	160	63	135	30	36	18.5	34	16	60	6	6

- \parallel - Note: This product conforms with the ISO 1179-1 standard and the ISO 228-1 standard.

Ordering data

Piston \varnothing	Stroke	Flange mounting	
		Part No.	Type
32	20	164 880	STAF-32-20-P-A-K
50	30	164 881	STAF-50-30-P-A-K
80	40	164 895	STAF-80-40-P-A-K

Stopper cylinders STA/STAF

Accessories



Sub-base ZVA

for stopper cylinder with flange

Material:

Wrought aluminium alloy

Free of copper, PTFE and silicone

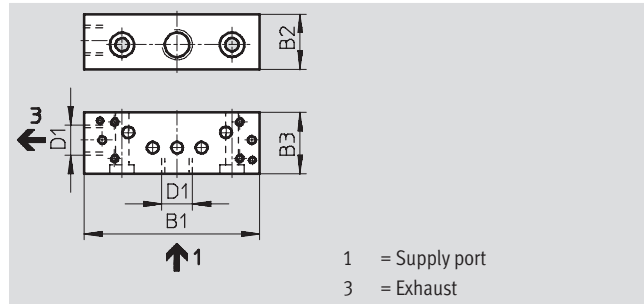
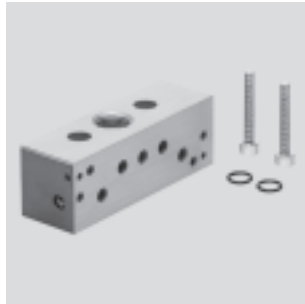

Dimensions and ordering data

For \varnothing	B1	B2	B3	D1	CRC ¹⁾	Weight	Part No.	Type
[mm]						[g]		
32	56	18	20	G $\frac{1}{8}$	2	50	164 896	ZVA-1
50/80	57.5	18	20	G $\frac{1}{8}$	2	52	164 897	ZVA-2

1) Corrosion resistance class 2 as per Festo standard 940 070

Components subject to moderate corrosion stress. Externally visible parts with primarily decorative surface requirements which are in direct contact with a normal industrial environment or media such as coolants or lubricating agents.

Stopper cylinders STA/STAF

Accessories

FESTO

Dimensions

Download CAD data → www.festo.com

Mounting dimensions for solenoid valves with sub-base ZVA on stopper cylinders

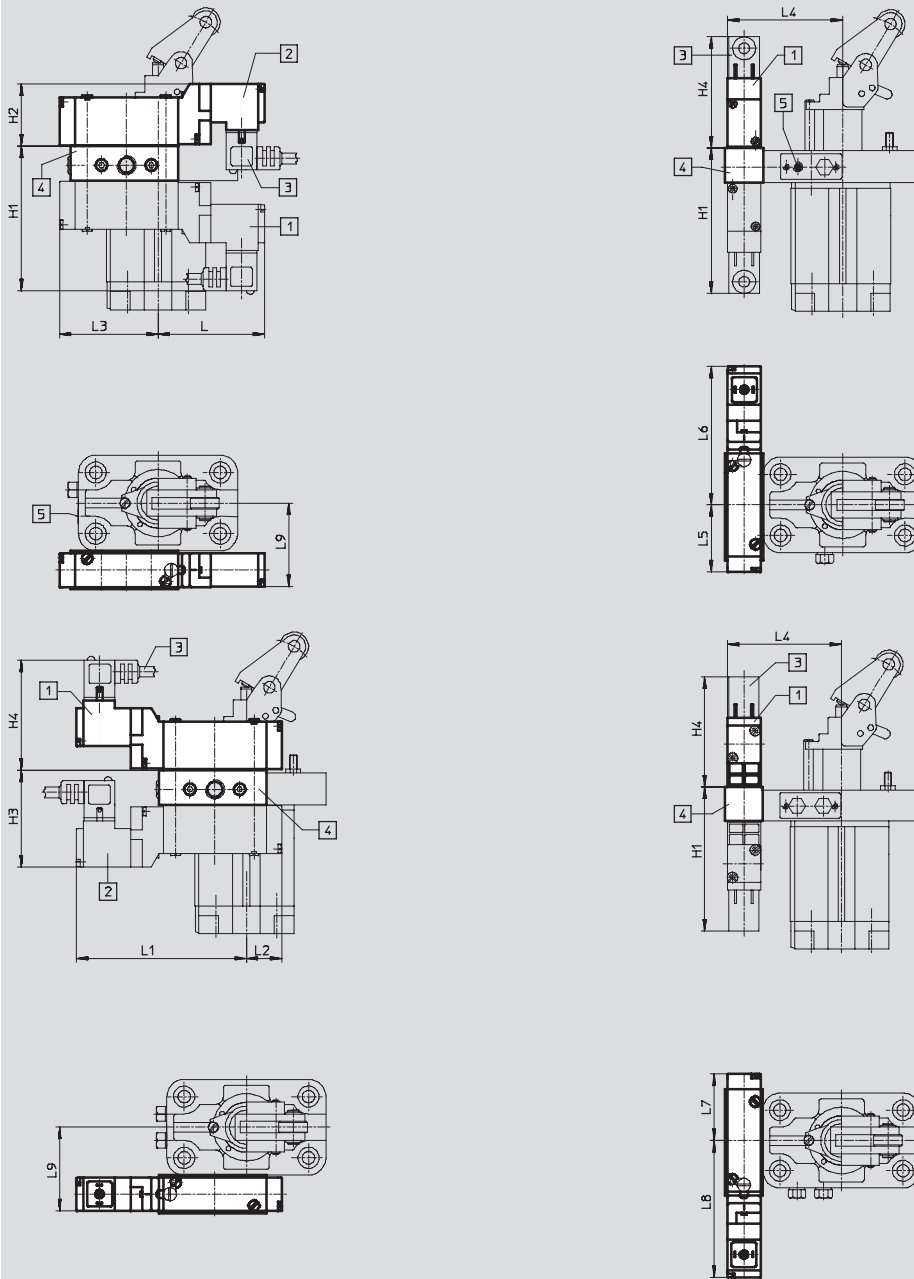

- 1 Solenoid can be rotated by 180°
- 2 Solenoid rotated 180° (not as supplied)
- 3 Plug socket KME
- 4 Sub-base
- 5 Filter nipple with 3/2-way valves, blanking plug with 5/2-way valves



For Ø [mm]	L	L1	L2	L3	L4	L5	L6
32	55.5	88.5	18.5	51.5	59	35	72
50	65	79	28	42	73	36	71
80	48.5	95.5	11.5	58.5	98	39	68



For Ø [mm]	L7	L8	L9	H1	H2	H3	H4
32	35	72	42	74.5	33.5	48.5	59.5
50	34	73	52	77	31	31	57
80	31	76	71	79	29	53	56

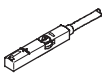

Stopper cylinders STA/STAF

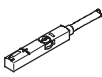
Accessories

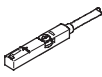
FESTO

Ordering data – Proximity sensors for T-slot, magneto-resistive						Technical data → Internet: smt
	Type of mounting	Switch output	Electrical connection	Cable length [m]	Part No.	Type
N/O contact						
	Insertable in the slot from above, flush with cylinder profile	PNP	Cable, 3-wire	2.5	543 867	SMT-8M-PS-24V-K-2,5-OE
			Plug M8x1, 3-pin	0.3	543 866	SMT-8M-PS-24V-K-0,3-M8D
			Plug M12x1, 3-pin	0.3	543 869	SMT-8M-PS-24V-K-0,3-M12
		NPN	Cable, 3-wire	2.5	543 870	SMT-8M-NS-24V-K-2,5-OE
			Plug M8x1, 3-pin	0.3	543 871	SMT-8M-NS-24V-K-0,3-M8D
			Plug M12x1, 3-pin	0.3	543 872	SMT-8M-NS-24V-K-0,3-M12
	Insertable in the slot lengthwise, flush with the cylinder profile	PNP	Cable, 3-wire	2.5	175 436	SMT-8-PS-K-LED-24-B
			Plug M8x1, 3-pin	0.3	175 484	SMT-8-PS-S-LED-24-B
N/C contact						
	Insertable in the slot from above, flush with cylinder profile	PNP	Cable, 3-wire	7.5	543 873	SMT-8M-PO-24V-K7,5-OE

Ordering data – Proximity sensors for T-slot, magnetic reed						Technical data → Internet: sme	
	Type of mounting	Switch output	Electrical connection	Cable length [m]	Part No.	Type	
N/O contact							
	Insertable in the slot from above, flush with cylinder profile	Contacting	Cable, 3-wire	2.5	543 862	SME-8M-DS-24V-K-2,5-OE	
				5.0	543 863	SME-8M-DS-24V-K-5,0-OE	
			Plug M8x1, 3-pin	Cable, 2-wire	2.5	543 872	SME-8M-ZS-24V-K-2,5-OE
				0.3	543 861	SME-8M-DS-24V-K-0,3-M8D	
	Insertable in the slot lengthwise, flush with the cylinder profile	Contacting	Cable, 3-wire	2.5	150 855	SME-8-K-LED-24	
			Plug M8x1, 3-pin	0.3	150 857	SME-8-S-LED-24	
N/C contact							
	Insertable in the slot lengthwise, flush with the cylinder profile	Contacting	Cable, 3-wire	7.5	160 251	SME-8-O-K-LED-24	

Ordering data – Connecting cables					Technical data → Internet: nebu
	Electrical connection, left	Electrical connection, right	Cable length [m]	Part No.	Type
	Straight socket, M8x1, 3-pin	Cable, open end, 3-wire	2.5	541 333	NEBU-M8G3-K-2.5-LE3
			5	541 334	NEBU-M8G3-K-5-LE3
	Angled socket, M8x1, 3-pin	Cable, open end, 3-wire	2.5	541 338	NEBU-M8W3-K-2.5-LE3
			5	541 341	NEBU-M8W3-K-5-LE3

Ordering data – Slot cover for T-slot					
	Assembly	Length [m]	Part No.	Type	
	Insertable from above	2x 0.5	151 680	ABP-5-S	