

- Picture sampling rate
185 ... 2,000 pictures per second
- Several cameras can be networked via
Ethernet
- Recording and storage electronics
integrated in the camera
- Compact dimensions,
low weight
- Protection class IP65, 67

Intelligent Compact Vision System SBOC-M/SBOI-M

Modern automation systems are for the most part designed for high production speeds which the human eye has trouble following. Festo offers the intelligent Compact Vision System SBOC-M/SBOI-M as an innovative and low-cost alternative to conventional high-speed cameras, for diagnosis and commissioning as well as function monitoring of high-speed motion sequences.



High speed

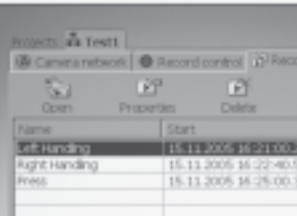

Documentation

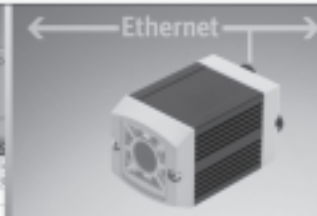

Networking

Impressive technology

Compact design with integrated electronics for recording, storing, etc. motion sequences.

PC software for straightforward commissioning as well as visualisation and archiving of recorded sequences.

Impressive economy

Simplified fault localisation thanks to reliable analysis and diagnosis of individual or cyclical high-speed motion sequences. Easy to handle with optimum adjustment and monitoring. It provides a highly cost-effective solution to many applications, from commissioning and servicing through to preventative maintenance.



- Integrated: complete evaluation electronics
- Sturdy: IP65/IP67 protection
- Networking and synchronisation: Ethernet interface
- High frame rate: 185 ... 2,000 fps

Impressive productivity

- Reduces the effort and costs involved in commissioning and maintenance
- Reliable processes with high cycle rates
- Functionality can be extended through software updates if necessary
- Straightforward commissioning via PC software
- Permits the archiving of any desired number of recordings

Compact Vision System SBOC-M/SBOI-M

Key features

FESTO

Problem description

Modern automation systems are for the most part designed for high production speeds which the human eye has trouble following.

Disadvantage of this high speed: Fitters and service employees cannot detect errors in the motion sequence and their causes straight away.

It is also becoming increasingly difficult to set the system parameters to their optimum values.

Typical applications

Mobile deployment of the high-speed camera for service and commissioning to increase the productivity and availability of automation systems

- Cycle time reduction through pinpointing of idle periods in motion sequences
- Optimum harmonisation of the travel times of individual axes in multi-axis systems, localisation of critical movements
- Time-synchronised visualisation of movement processes from several sides on a PC for greater ease of handling
- Localisation of unwanted vibrations which have a negative effect on the repetition accuracy of movement processes and can cause premature material fatigue

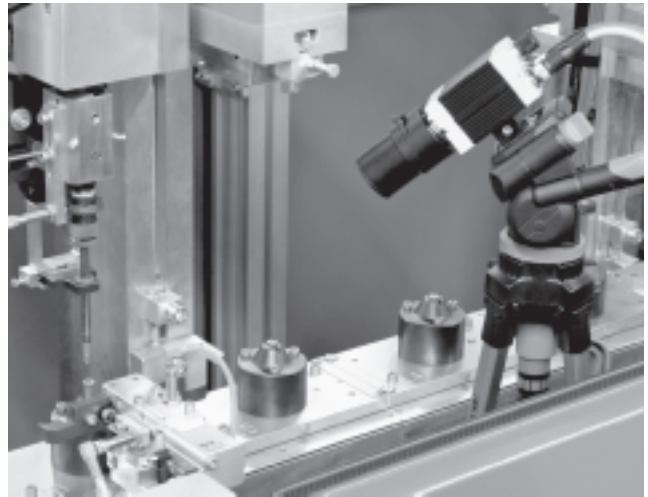

Stationary mounting of the high-speed camera to increase the availability of automation systems

- Continuous recording of processes in the ring buffer of the camera
- If a fault occurs, recording is stopped by an external signal. The case history of the fault is then stored in the camera, thus permitting an analysis of the cause

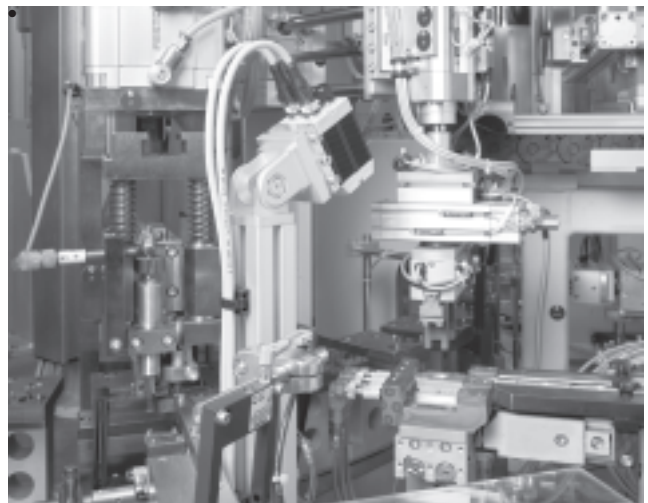

Interfaces

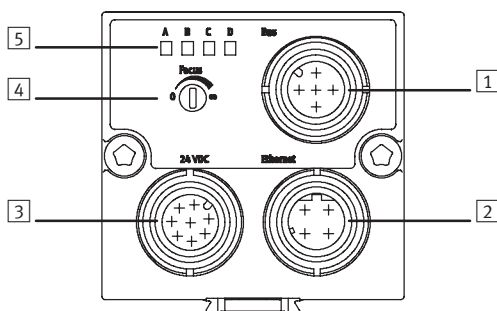

- 1 Bus connection
- 2 Ethernet connection
- 3 Power supply and inputs/outputs
- 4 Adjusting screw for focus

- 5 Status LEDs:
 - A Operating system
 - B Ethernet traffic
 - C Recording
 - D Recording status

Compact Vision System SBOC-M/SBOI-M

Key features



FCT software with SBO.. Network plug-in

Configuring a camera network

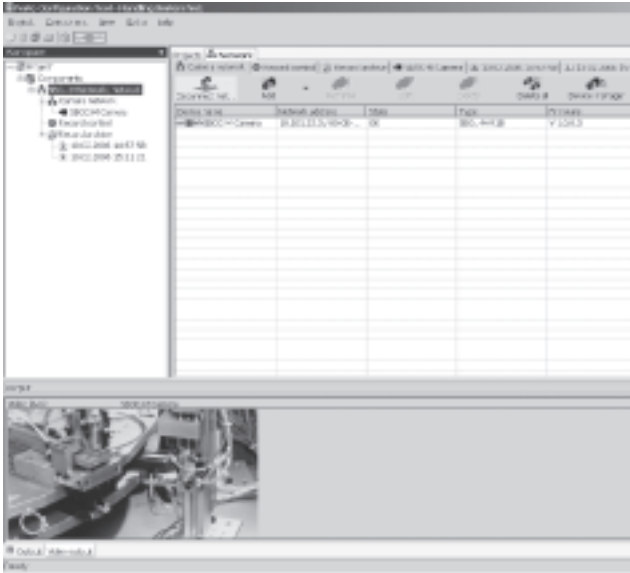

The "SBO..-M Network" is a plug-in for the Festo configuration tool (FCT for short). It provides the following functions:

- Configuration and commissioning of a camera network with any desired number of Compact Vision Systems of the type SBOC-M or SBOI-M
- Creation of time-synchronised recordings using all devices in the camera network in order to record a scene from various angles, for example

Setting the camera

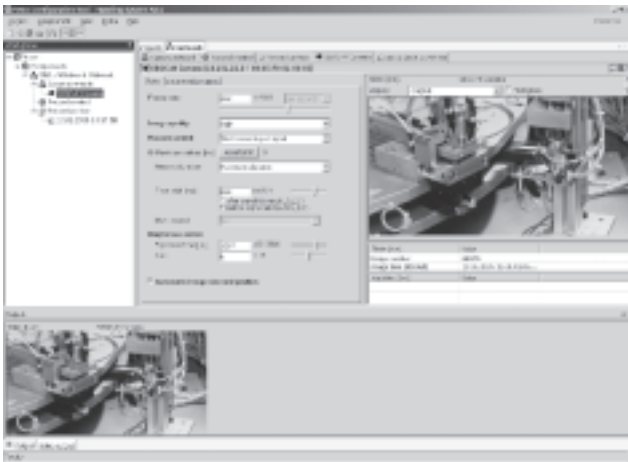

Using the live pictures from the camera, the lens can be set and parameters such as exposure time, frames per second, recording duration and picture quality, for example, adjusted.

With the parameters you can also define what is to happen when a trigger signal (edge change of an external 24 V signal) occurs:

- Start the recording
- Stop the recording
- Record only one picture

Time delays between trigger signal and start of recording or stop recording as well as recording several films or pictures in the camera memory (multi-recording) can also be determined in a user-friendly manner.

Recording control

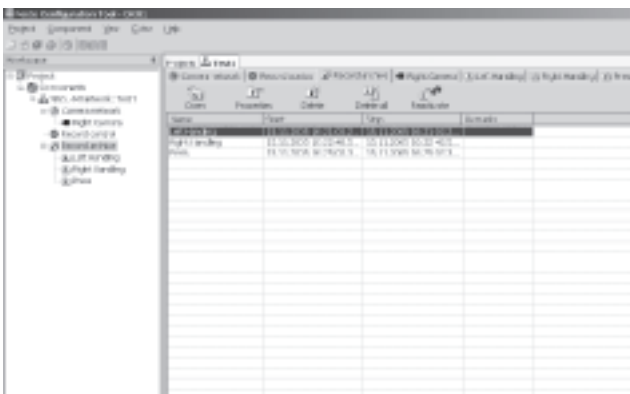

Recording can be started once the camera has been set up. You can choose whether the camera should wait for the occurrence of an external trigger condition, start recording directly following initialisation or store the pictures sent via Ethernet on a PC without buffering them in the camera. The PC can be removed once recording has been started in "Wait for trigger

signal" mode. The camera operates automatically and waits for the trigger condition to occur. Recorded sequences are stored in the internal memory of the respective camera and can be transmitted to the FCT software once a connection has been re-established with a PC. The sequences are archived and can be analysed on the PC.

Compact Vision System SBOC-M/SBOI-M

Peripherals overview

FESTO

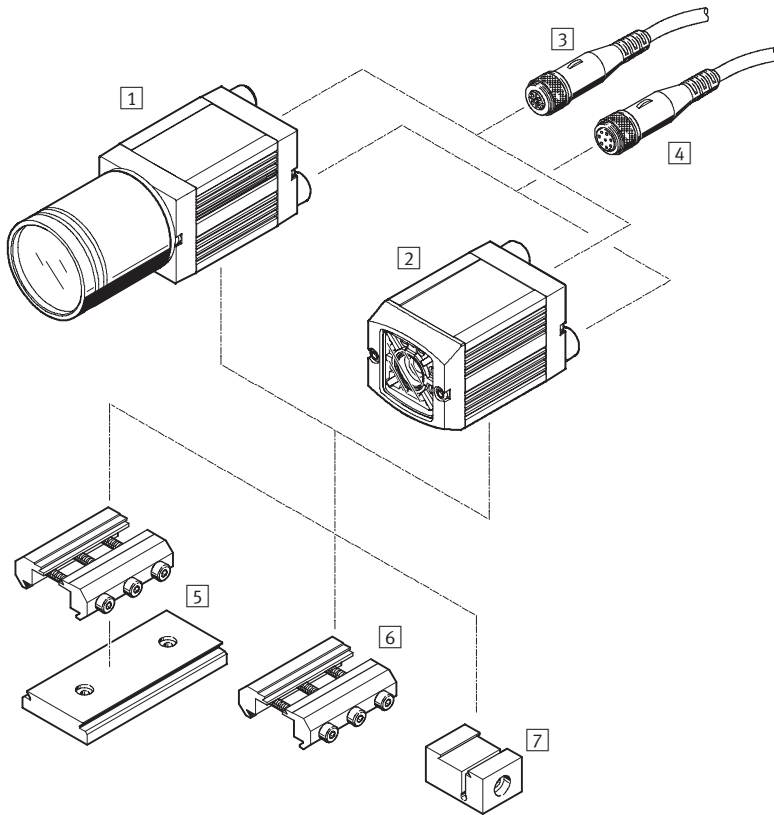

Accessories	Brief description	→ Page/Internet
Compact Vision System		
1	SBOC-M-R1B	For standard lens with C mount connection
2	SBOI-M-R1B	With integrated lens and light
-	SBOA-M-SYSTAINER	Systainer with Compact Vision System SBOC-M-R1B and an extensive range of accessories
Cable with socket		
3	SBOA-K30E-M12S	Ethernet diagnostic cable
4	SIM-M12-8GD-...-PU	For supplying the operating voltage
Lens		
-	SBOL-12	Focal distance 12 mm
-	SBOL-25	Focal distance 25 mm
Mounting components		
5	Adapter kit SBOA-HMSV-39	With screw-on adapter plate
6	Adapter kit SBOA-HMSV-40	Without screw-on adapter plate
7	Adapter kit SBOA-HMSV-41	With female thread G1/4 for mounting on commercially available tripods
-	Adapter SBOL-C-5	5 mm spacer ring (CS mount to C mount)

Compact Vision System SBOC-M/SBOI-M

Type codes

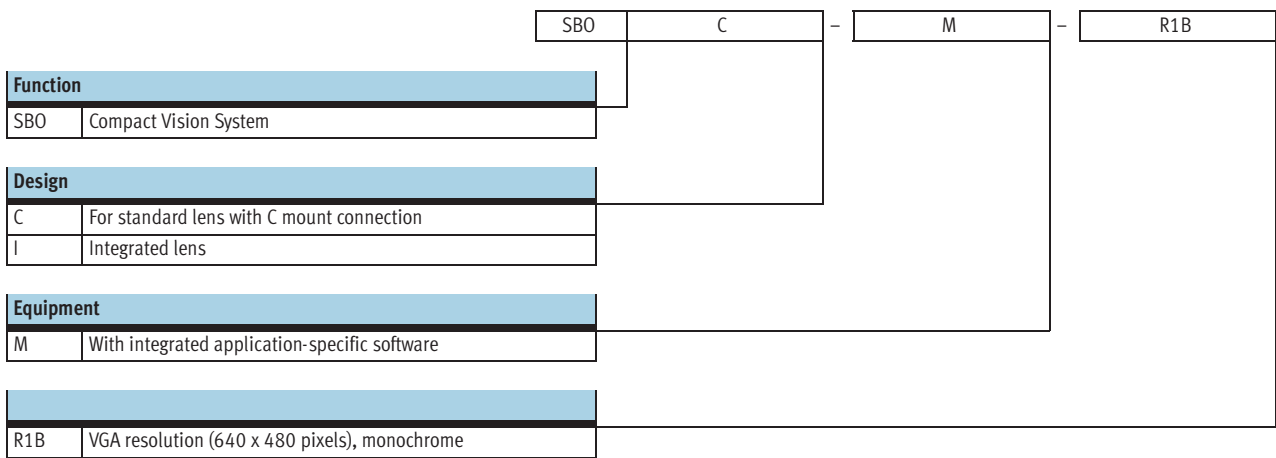

Compact Vision System SBOC-M/SBOI-M

FESTO

Technical data

-  - Voltage
24 V DC

-  - Temperature range
-10 ... +50 °C

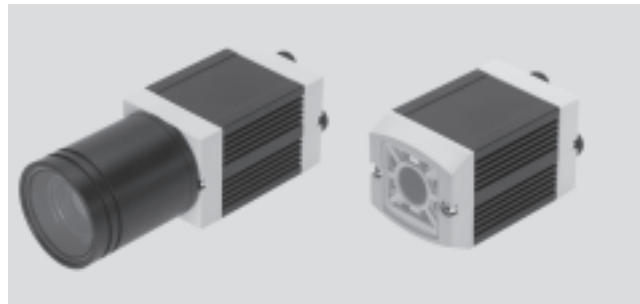

General technical data		
	SBOC-M	SBOI-M
Lens mounting	C mount	Integrated lens
Operating distance [mm]	Dependent on the lens selected	22 ... 1,000
Field of vision [mm]	Dependent on the lens selected	14x10 ... 520x390
Exposure time [ms]	0.04 ... 1,000	
Frame rate (full image) [fps]	185	
Sensor resolution [pixels]	640x480	
Sensor type	Monochrome	

Electrical data		
Nominal operating voltage [V DC]	24	
Permissible voltage fluctuations	±10%	
Max. residual current [A]	1.5 at the 24 V outputs	
Current consumption [mA] with load-free outputs	120	
Bus connection	Ethernet interface IEEE802.3U (100BaseT) 100 Mbit/s TCP/IP M12	
Protection class	IP65/IP67	

Operating and environmental conditions		
Ambient temperature [°C]	-10 ... +50	
Storage temperature [°C]	-10 ... +60	
Ambient conditions	Screened from extreme external light sources Cleanest possible ambient air	

Materials	
Housing	Anodised aluminium
Cap	Acrylic butadiene styrene, glass fibre reinforced
Material note	Free of copper and PTFE

Weight [g]		
	SBOC-M	SBOI-M
Compact Vision System	182	184

Compact Vision System SBOC-M/SBOI-M

Technical data

FESTO

Dimensions

SBOC-M

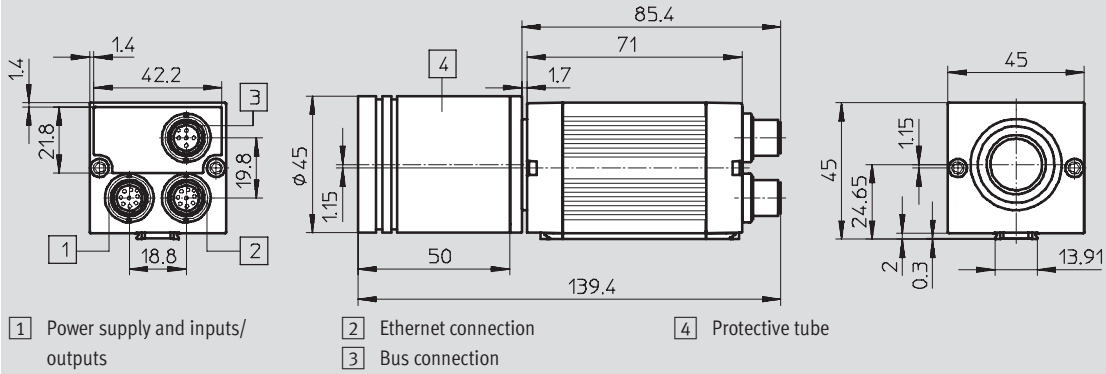

SBOI-M

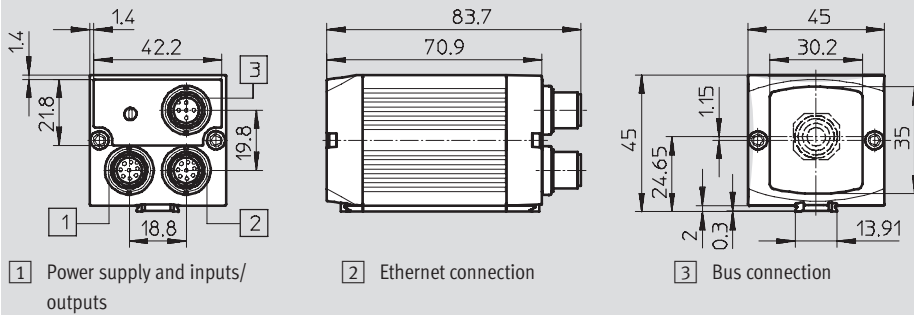

Ordering data

Design	Part No.	Type
For standard lens with C mount connection	541 398	SBOC-M-R1B
Integrated lens	541 395	SBOI-M-R1B

Compact Vision System SBOC-M/SBOI-M

Accessories

FESTO

Adapter kit

SBOA-HMSV-39

with screw-on adapter plate

Material:

Wrought aluminium alloy, anodised

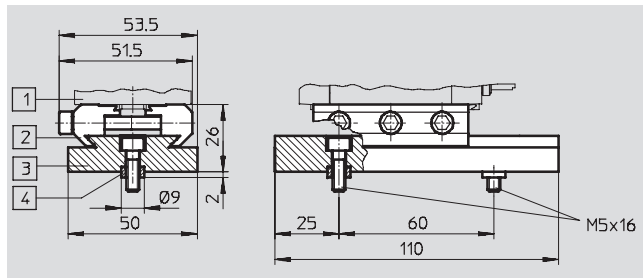

Ordering data		
	Part No.	Type
Adapter kit	541 599	SBOA-HMSV-39

Adapter kit

SBOA-HMSV-40

without screw-on adapter plate

Material:

Wrought aluminium alloy, anodised

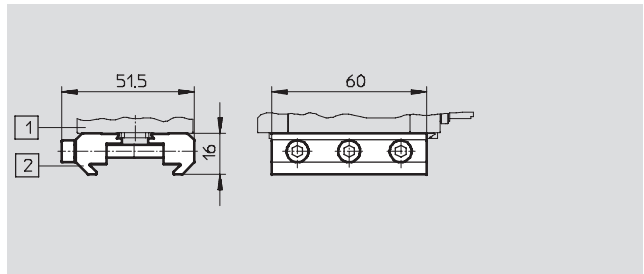

Ordering data		
	Part No.	Type
Adapter kit	541 600	SBOA-HMSV-40

Adapter kit

SBOA-HMSV-41

with female thread G $\frac{3}{4}$ for mounting on commercially available tripods

Material:

Wrought aluminium alloy, anodised

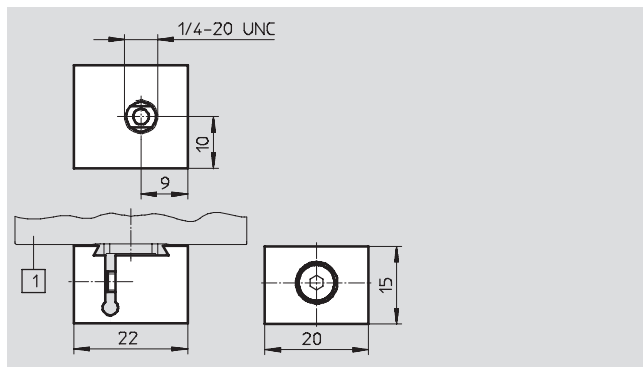

Ordering data		
	Part No.	Type
Adapter kit	542 140	SBOA-HMSV-41

Compact Vision System SBOC-M/SBOI-M

Accessories



Adapter SBOL-C-5

5 mm spacer ring
(CS mount to C mount)

Material:
Wrought aluminium alloy, anodised

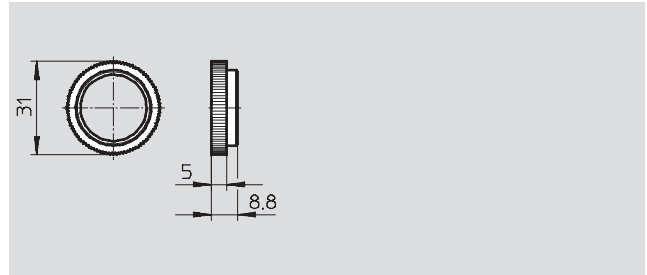

Ordering data		
	Part No.	Type
Adapter	541 601	SBOL-C-5

Systainer with Compact Vision System SBOA-M-SYSTAINER

- Camera SBOC-M-R1B
- Mounting kit for tripod
- Zoom lens (10 – 40 mm)
- Plug-type power supply unit incl. trigger button
- Extension cable for triggering button
- Manual cable drum
- M12 to RJ45 Ethernet cable
- Ethernet crossover patch cable
- RJ45 coupling
- 1,000 W light
- 2 tripods (one each for camera and light)
- FCT configuration software
- Documentation package



Ordering data		
	Part No.	Type
Systainer with Compact Vision System SBOC-M-R1B and accessories	543 408	SBOA-M-SYSTAINER



Ordering data – Lens				
	Brief description	Focal distance [mm]	Part No.	Type
	C mount with fixed focal distance	12	549 132	SBOL-12
		25	549 133	SBOL-25

Ordering data – Cables M12x1					Technical data → Internet: sim, soba	
	Assembly	Use	Connection	Cable length [m]	Part No.	Type
Straight socket						
	Union nut M12x1	Operating voltage supply	8-pin	2	525 616	SIM-M12-8GD-2-PU
				5	525 618	SIM-M12-8GD-5-PU
	Union nut M12x1	Ethernet diagnostic cable	4-pin, d-coded	3	542 139	SBOA-K30E-M12S

Compact Vision System SBOC-M/SBOI-M

Accessories

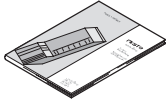
FESTO

Ordering data – Documentation				
	Brief description	Language	Part No.	Type
	Description User documentation in paper form is not included in the scope of delivery of the camera system.	German	542 122	P.BE-SBO-M-DE
		English	542 123	P.BE-SBO-M-EN
	Documentation package The user documentation on CD-ROM is included in the scope of delivery of the Compact Vision System.	German English	542 121	P.BE-SBO-M-UDOK
	Configuration software The FCT (Festo configuration tool) configuration software on CD-ROM is included in the scope of delivery of the Compact Vision System.	German English French	539 622	P.SW-FCT