

Handling modules HSP



Handling modules HSP

Key features at a glance



Field of application

The handling module is a new generation of function modules for the automatic transfer, feed and removal of small parts in extremely confined spaces. This is achieved by means of a guided vertical and horizontal motion sequence. A backlash-free cross-guide

with recirculating ball bearing elements ensures high precision and good rigidity. The combination of a semi-rotary drive and a slotted guide system produces a compact unit for a complete pick & place cycle.

Special features

- Compact design
- Extremely short cycle times
- Low cost
- Simple commissioning
- For working loads up to 1.6 kg
- Stroke adjustment along Y- and Z-axes
- Wait positions possible
- No planning costs

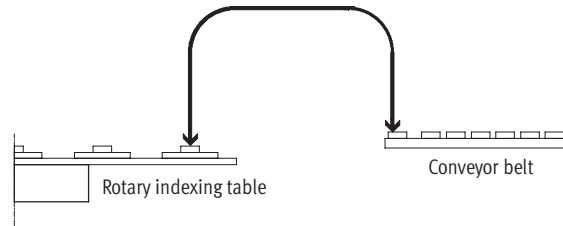

Three drive variants are available

| | Pneumatic: HSP-...-AP, with swivel module DSM | Electric: HSP-...-AE, with servo motor unit MTR-DCI-...-HM | Without drive: HSP-...-AS, with drive shaft |
|---------------------------------------|---|--|---|
| | | | |
| Advantages | | | |
| | <ul style="list-style-type: none"> • Fast • Cost-effective • Ready to install • No system planning required • Simple commissioning | <ul style="list-style-type: none"> • Freely positionable • Freely selectable speed • Smooth motion sequence • Ready to install • No system planning required • Simple commissioning using teach-in procedure | <ul style="list-style-type: none"> • Compact • Universal compatibility • Variable drive interface • On request: Drive options in combination with servo motors MTR-AC |
| Technical data | | | |
| Stroke | Y [mm] | 52 ... 170 | |
| | Z [mm] | 20 ... 70 | |
| Min. cycle time | [s] | 0.6 ... 1.0 | 0.8 ... 1.2 |
| Working load | [g] | 0 ... 1600 | |
| Repetition accuracy at end positions | [mm] | ±0.02 | |
| Wait positions | | Max. 2 | Any |
| Function of wait position | | Pulling with return cylinder | Freely approachable |
| Repetition accuracy at wait positions | [mm] | < 1 | < 2 |
| Data sheet | | → 8 | → 18 |
| | | | → 32 |

Handling modules HSP

Typical applications

HSP...-AP, pneumatic

Linear transfer

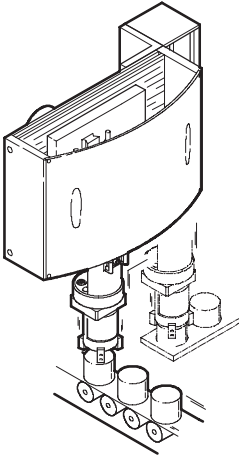

- Fast feed and removal, e.g. for linear transfer or rotary indexing table

Belt-type part positioning

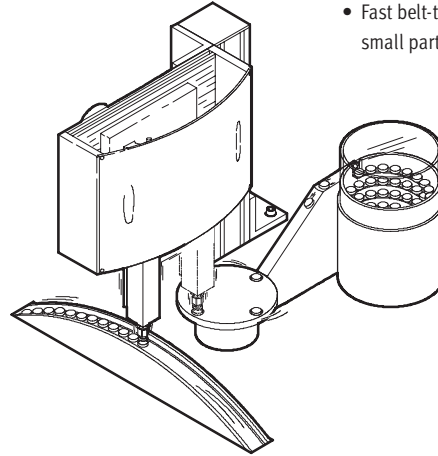

- Fast belt-type part positioning of small parts

HSP...-AE, electric

Rotary indexing table

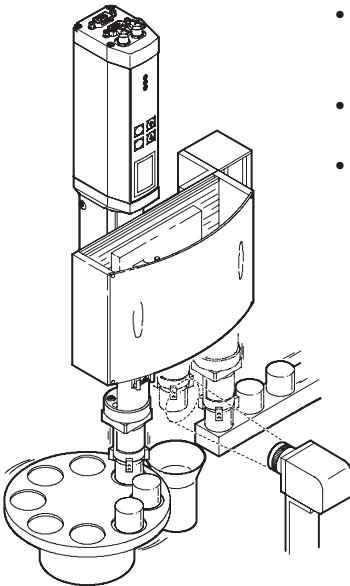

- Flexible pick & place unit with quality inspection of components and ejector for reject parts
- Handling of parts with different heights
- Handling at different speeds, e.g. for linear transfer or rotary indexing table

Rotary indexing table

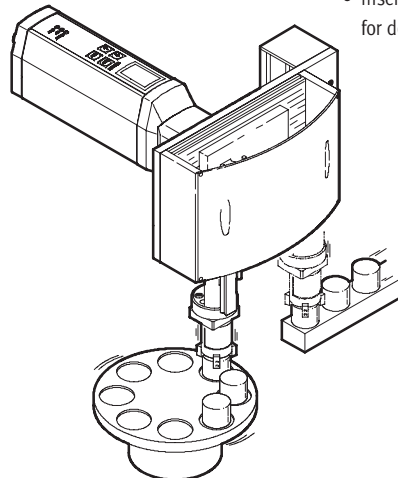

- Adjustable wait position module directly above workpiece/workpiece carrier
- Insertion tasks at different speeds for delicate components

HSP...-AS, without drive

Linear transfer

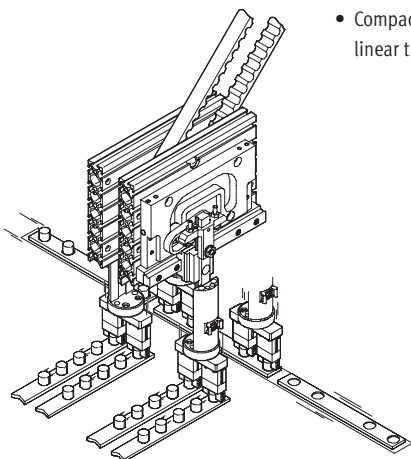

- Compact twin pick & place unit for linear transfer

Rotary indexing table, linear transfer

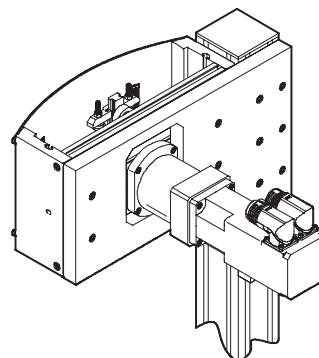

- Fast and flexible pick & place unit with servo motor EMMS-AS
- Electrical variant using third-party motor

Handling modules HSP

Key features at a glance

HSP...-AP – pneumatic with swivel module DSM

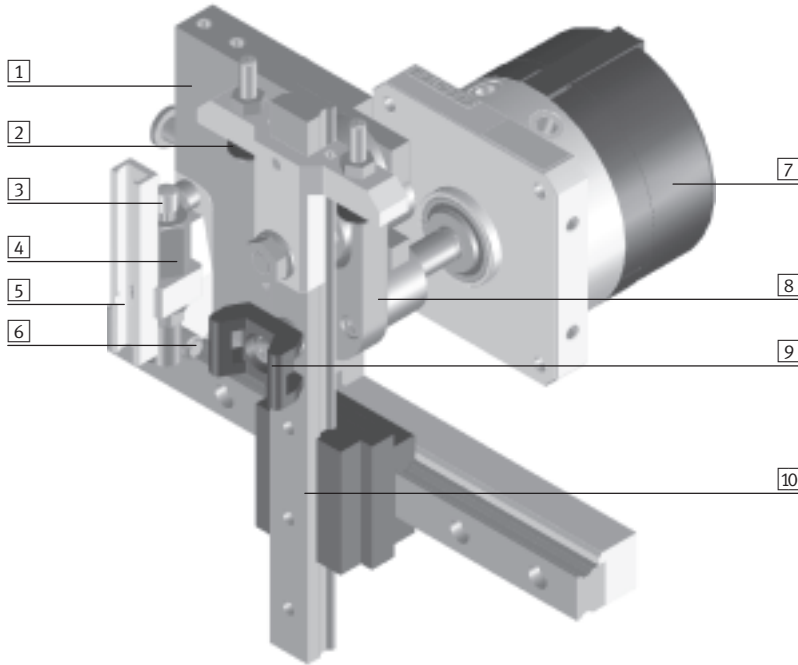

- 1 Slotted guide plate
- 2 Adjustable stop
- 3 Shock absorber YSRW
- 4 Stop sleeve
- 5 Sensor rail
- 6 Pressure piece
- 7 Swivel module DSM
- 8 Swivel lever
- 9 Cable binder holder
- 10 Cross-guide

HSP...-AS – without drive (rear side)

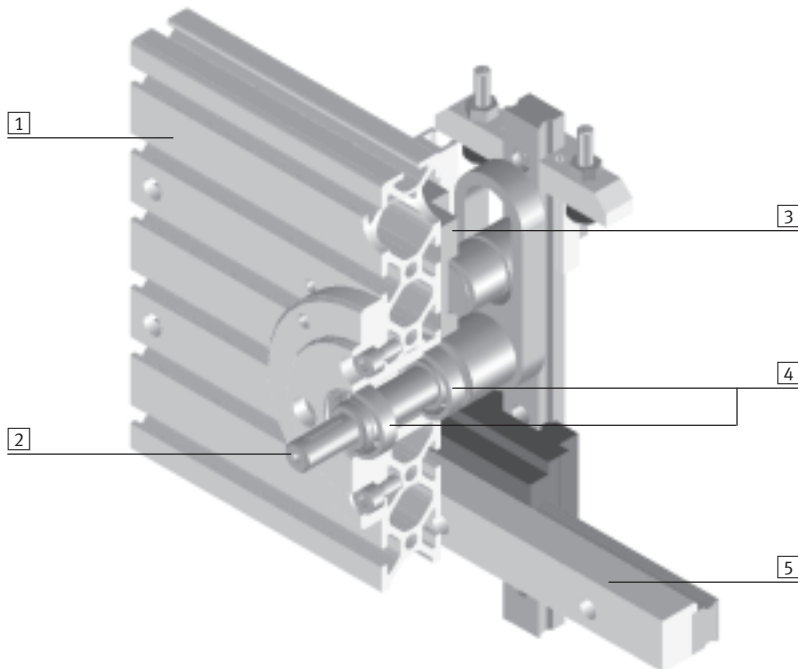

- 1 Back plate
- 2 Shaft with Woodruff key
- 3 Slotted guide plate
- 4 Ball bearings
- 5 Aluminium rail for alignment of slotted guide plates

Handling modules HSP

Key features at a glance

HSP-...-AE – electrical version with servo motor unit MTR-DCI-...-HM

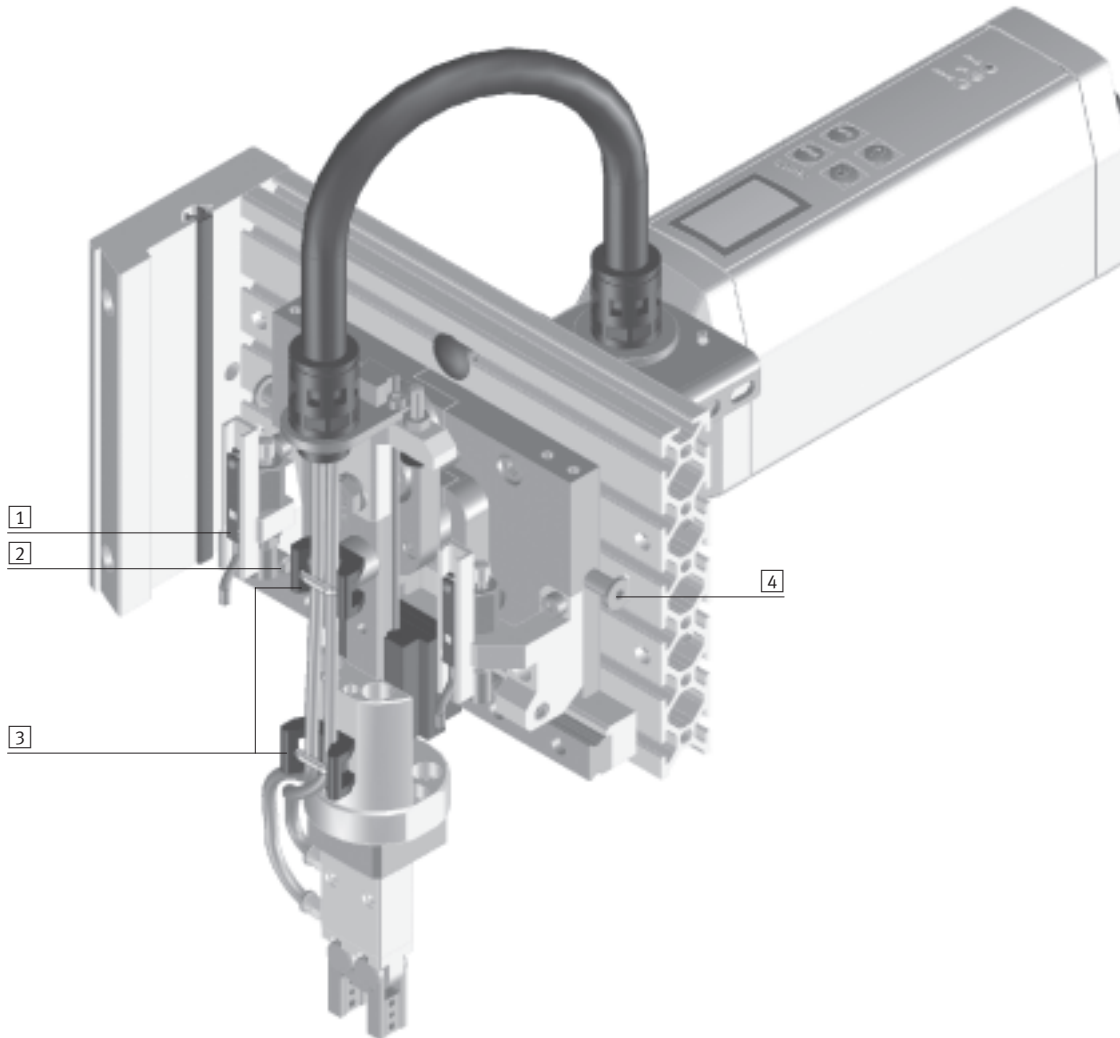

The technology in detail



1 Proximity sensor cables are installed via profile slots in the side and back plate.



2 The pressure piece guarantees freedom from backlash and precision at the end positions and in the effective linear stroke along the Z-axis.



3 Cable binder holders facilitate the secure routing of tubing and cables.



4 The adjustable slotted guide plate permits precise stroke setting.

Handling modules HSP

Peripherals overview

FESTO

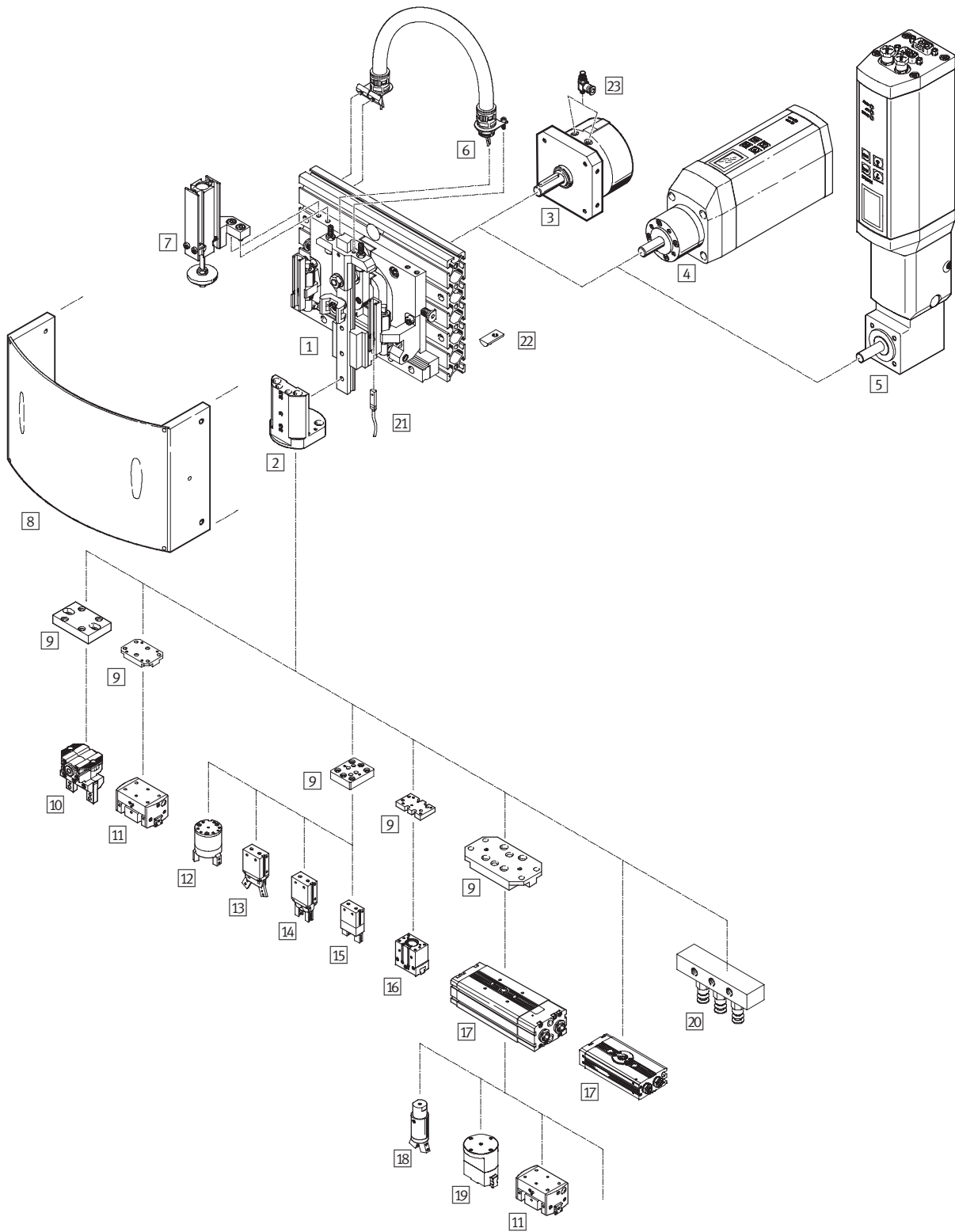

Handling modules HSP

Peripherals overview

FESTO

| Accessories | | | | | | |
|-------------|--|---|--|----|-----------------|-------------|
| | Brief description | 12 | 16 | 25 | → Page/Internet | |
| 1 | Handling module HSP | Standard module without accessories | ■ | ■ | ■ | 9 |
| 2 | Adapter kit HAPG | Interface for grippers, semi-rotary drives, etc. | ■ | ■ | ■ | 36 |
| 3 | Swivel module DSM | Pneumatic drive, adapted to each size | ■ | ■ | ■ | dsm |
| 4 | Motor unit MTR-DCI-...-HM | Servo motor with integrated power electronics | ■ | ■ | ■ | 25 |
| 5 | Motor unit MTR-DCI-...-HM | Servo motor with angle gear unit and integrated power electronics | ■ | ■ | ■ | 25 |
| 6 | Installation kit MKRP | Conduit to protect electric cables and tubing | ■ | ■ | ■ | 36 |
| 7 | Wait position module BWL-/BWR-HSP | With pneumatic drive: Function for retracting the swivel arm from operating area | ■ | ■ | ■ | 37 |
| 8 | Cover kit BSD-HSP | To protect against accidental contact | ■ | ■ | ■ | 37 |
| 9 | Adapter kit HAPG | Interface between HSP and gripper or semi-rotary drive | – | ■ | ■ | 38 |
| 10 | Parallel gripper HGPC | Appropriate gripper for every application | – | ■ | ■ | 38 |
| 11 | Parallel gripper HGPP | | – | ■ | ■ | 38 |
| 12 | Three-point gripper HGD | | – | ■ | ■ | 38 |
| 13 | Angle gripper HGW | | ■ | ■ | ■ | 38 |
| 14 | Radial gripper HGR | | ■ | ■ | ■ | 38 |
| 15 | Parallel gripper HGP | | ■ | ■ | ■ | 38 |
| 16 | Parallel gripper HGPT | | ■ | ■ | ■ | 38 |
| 17 | Semi-rotary drive DRQD | | Semi-rotary drive for transferring parts | ■ | ■ | ■ |
| 18 | Angle gripper HGWM | Appropriate gripper for every application | ■ | ■ | ■ | hgwm |
| 19 | Parallel gripper HGPM | | ■ | ■ | ■ | hgpm |
| 20 | Suction cups | Appropriate suction cup for every application | ■ | ■ | ■ | suction cup |
| 21 | Proximity sensor SME-/SMT-8 | Sensing facility for end positions | ■ | ■ | ■ | 40 |
| 22 | Slot nut HMBN | Mounting element | ■ | ■ | ■ | 41 |
| 23 | Non-return and flow control valve GRLA | Speed setting of pneumatic drives | ■ | ■ | ■ | grla |

Handling modules HSP, pneumatic

Type codes

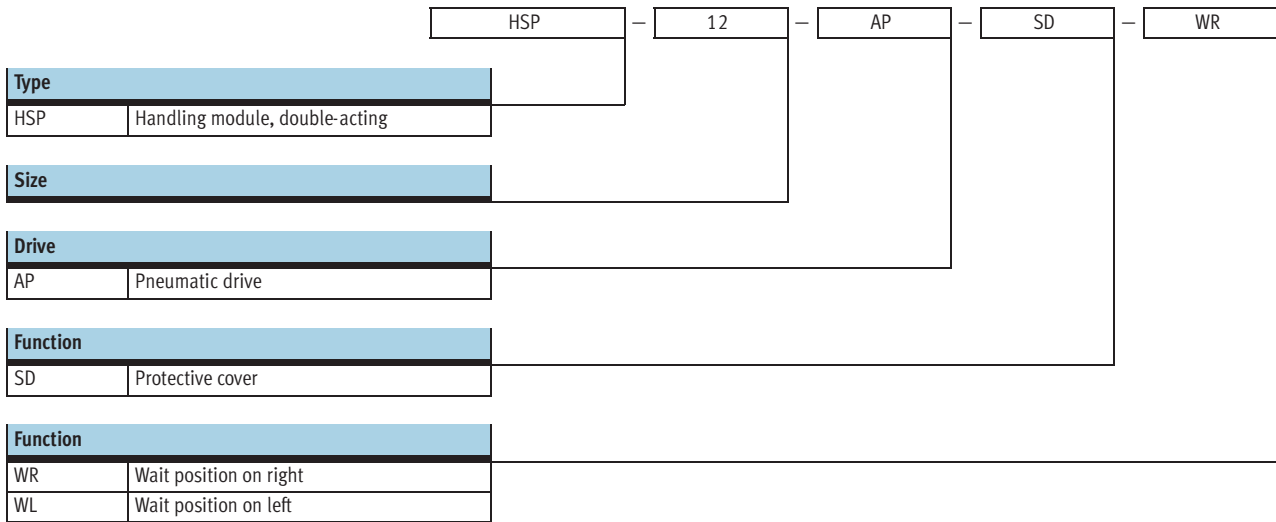

Handling modules HSP, pneumatic

Technical data

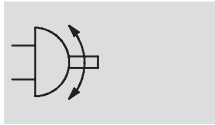

FESTO

Function

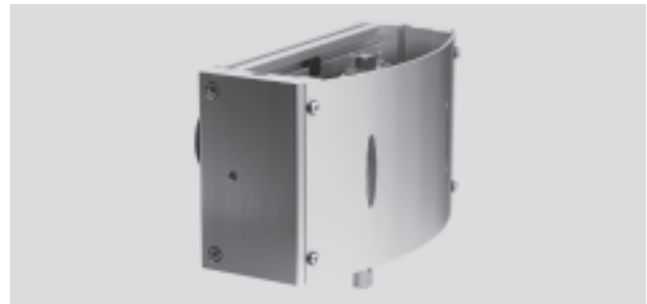

 www.festo.com



-  Size
12, 16 and 25
-  Y-stroke length
52 ... 170
-  Z-stroke length
20 ... 70

| General technical data | |
|------------------------|--|
| Type | HSP-...-AP |
| Pneumatic connection | M5 |
| Mode of operation | Double-acting |
| Operating medium | Filtered compressed air, lubricated or unlubricated |
| Constructional design | Swivel module |
| | Cross-guide |
| | Guided motion sequence |
| Cushioning | Shock absorber at both ends, soft characteristic curve |
| Position sensing | For proximity sensing |
| Type of mounting | With through-holes |
| | With slot nuts |
| Mounting position | Guide rail, vertical/horizontal |

| Operating and environmental conditions | |
|--|------------|
| Type | HSP-...-AP |
| Operating pressure [bar] | 4 ... 8 |
| Ambient temperature [°C] | 0 ... +60 |

| Stroke [mm] | | | | |
|----------------|----|-----------|------------|-------------|
| Size | | 12 | 16 | 25 |
| Y-axis | | | | |
| Stroke | | 52 ... 68 | 90 ... 110 | 130 ... 170 |
| Z-axis | | | | |
| Stroke | Z | 20 ... 30 | 35 ... 50 | 50 ... 70 |
| Working stroke | Za | 5 ... 15 | 5 ... 20 | 5 ... 25 |

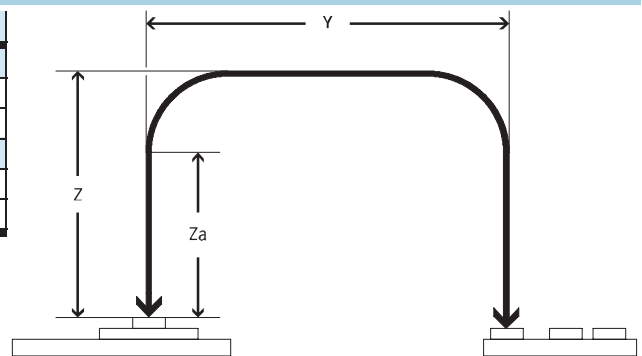

| Forces [N] | | | |
|---------------------------|----|----|----|
| Size | 12 | 16 | 25 |
| Z-axis | | | |
| Effective force at 6 bar | 40 | 50 | 65 |
| Y-axis | | | |
| Permissible process force | 30 | 35 | 50 |

Handling modules HSP, pneumatic

Technical data

FESTO

| Weight [g] | | | |
|------------------|------|------|------|
| Size | 12 | 16 | 25 |
| HSP-...-AP | 1900 | 2900 | 6400 |
| HSP-...-AP-SD | 2600 | 3400 | 7600 |
| HSP-...-AP-SD-WR | 2800 | 3600 | 8100 |
| HSP-...-AP-SD-WL | 2800 | 3600 | 8100 |

Repetition accuracy [mm]

To ensure low-vibration operation, the working load should be mounted as close as possible to the guide rail of the handling module.

Repetition accuracy is guaranteed by

mounting the working load (adapter plate, rotary drive and/or gripper, gripper finger, workpiece) within the mounting surface of the adapter kit HAPG.

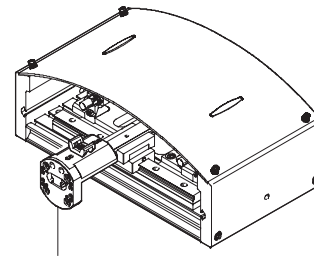

Mounting surface of HAPG

| Size | 12 | 16 | 25 |
|--------------------------------------|-------|-------|-------|
| Repetition accuracy at end positions | ±0.01 | ±0.01 | ±0.02 |

Travel times t as a function of working load m

The travel time t is the time taken for the handling module to move from one end position to the other and back again.

The working load m is the load attached to the vertical guide rail (e.g. adapter, gripper, semi-rotary drive and workpiece).

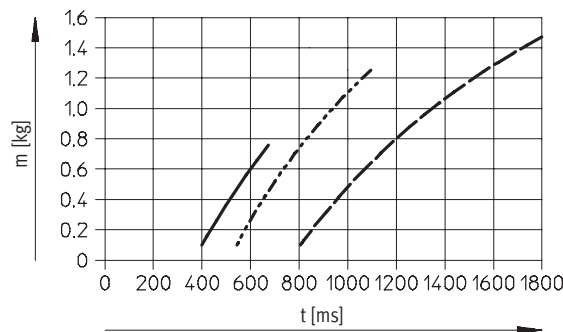

— HSP-12-AP
 - - - HSP-16-AP
 - · - HSP-25-AP

Cycle times [s]

The cycle time t_t comprises the travel time t and the dwell time t_e at the end positions.

$t_t = \text{travel time } t + \text{dwell time } t_e$
 The value must not fall below the minimum cycle time.

| Size | 12 | 16 | 25 |
|-----------------|-----|-----|-----|
| Min. cycle time | 0.6 | 0.8 | 1.0 |

Example for HSP-12-AP

Step 1:
 The following values are assumed:
 Working load $m = 0.15 \text{ kg}$
 Dwell time $t_e = 2 \times 50 \text{ ms}$
 (50 ms per end position)

Step 2:
 The travel time can be determined from the graph:
 $t = 400 \text{ ms}$

Step 3:
 This gives us a cycle time:
 $t_t = 400 \text{ ms} + 100 \text{ ms} = 500 \text{ ms}$

Step 4:
 The table gives us a min. cycle time of 600 ms. This means that the movement has to be controlled.

Handling modules HSP, pneumatic

Technical data

Permissible static/dynamic characteristic load values

Cross-guide

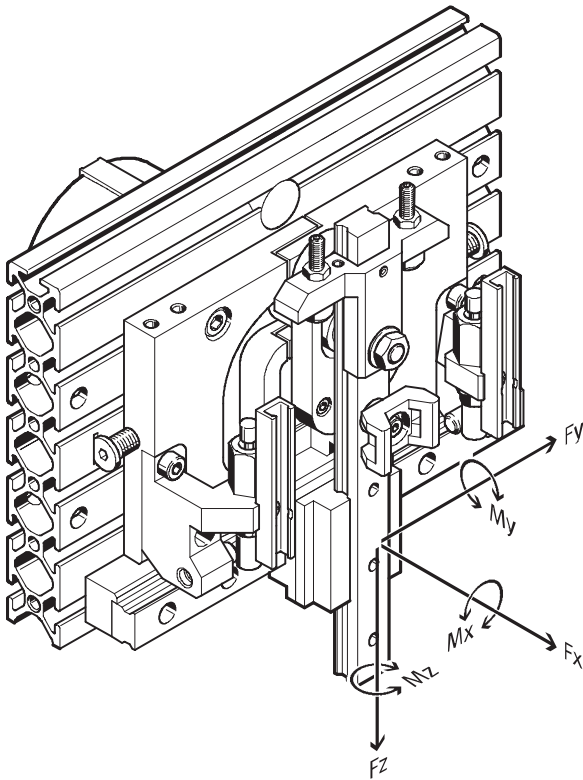

- - Note

The torques apply to the centre of the vertical guide.

Combined load

The following torque equation must be satisfied with combined load:

$$\frac{M_x}{M_{xperm.}} + \frac{M_y}{M_{yperm.}} + \frac{M_z}{M_{zperm.}} \leq 1$$

| Dynamic characteristic load values | | | |
|---|-----|-----|-----|
| Size | 12 | 16 | 25 |
| Max. torques [Nm] $M_{xperm.}, M_{yperm.}, M_{zperm.}$ | 1.1 | 2.4 | 3.2 |

Combined load

The following torque equation must be satisfied with combined load:

$$\frac{M_{ox}}{M_{oxperm.}} + \frac{M_{oy}}{M_{oyperm.}} + \frac{M_{oz}}{M_{ozperm.}}$$

| Static characteristic load values | | | |
|--|----|----|----|
| Size | 12 | 16 | 25 |
| Max. torques [Nm] $M_{oxperm.}, M_{oyperm.}, M_{ozperm.}$ | 5 | 10 | 15 |

Handling modules HSP, pneumatic

Technical data

FESTO

Stroke adjustment

Y stroke:

- Once the HSP has been mounted, the Y strokes of the pick and place position can be set independently of each other.

Z stroke:

- Differences in height, for example between a rotary indexing table and a transfer system, can be compensated after mounting.

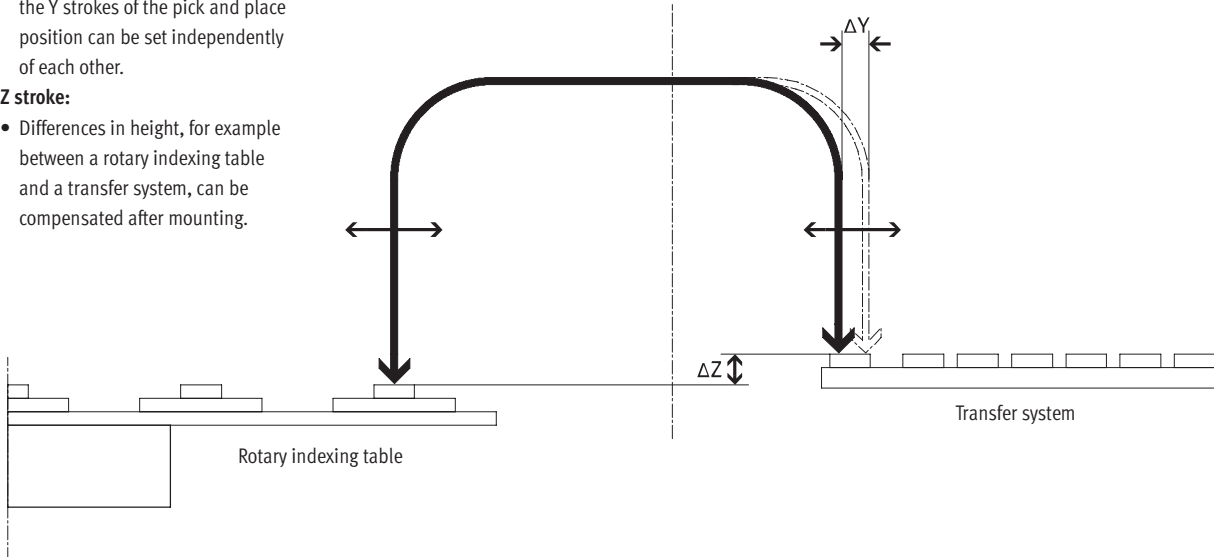

Y-axis (horizontal)

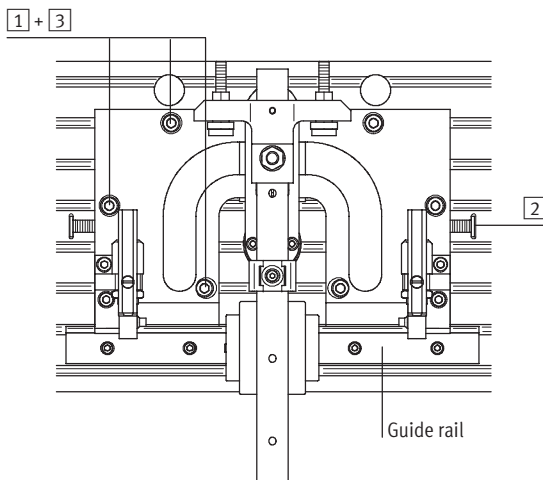

Procedure:

- Loosen the screws
- Adjust the slotted guide plate using the adjustment screw (the slotted guide plate must always make contact with the guide rail)
- Tighten the screws

Z-axis (vertical)

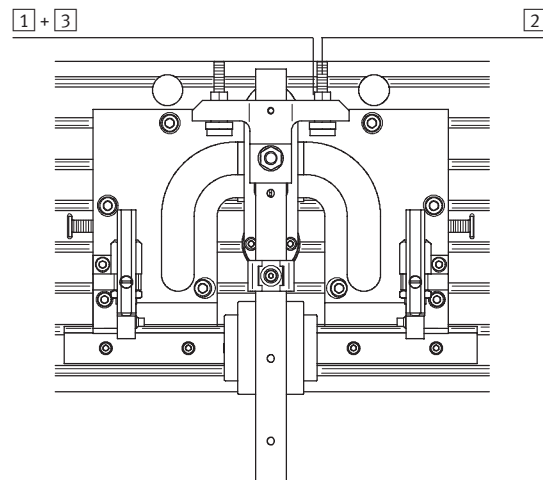

Procedure:

- Loosen the lock nut
- Set the desired Z stroke using the set screw
- Tighten the lock nut

Handling modules HSP, pneumatic

Technical data

Wait position module

Application and mode of operation

Figure 1:

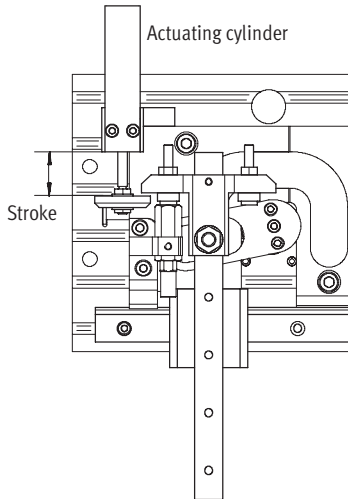
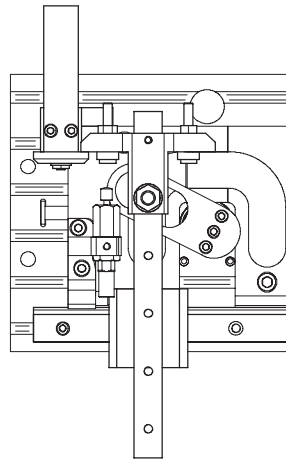
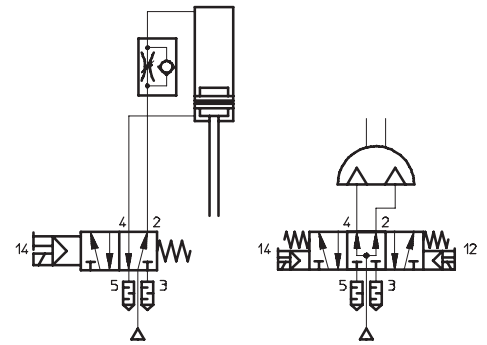

Figure 2:



Circuit diagram for HSP with wait position module



- 1 The handling module HSP is at the right-hand end position. The actuating cylinder is extended in its initial position.
- 2 The 5/3-way valve is reset once the handling module reaches the left-hand end position. (Figure 1)
- 3 During retraction, the actuating

cylinder pulls the handling module upwards to its wait position. The operating area is then free. (Figure 2)

- 4 From the wait position, the handling module can move either to the initial position or to the other end position.

Cycle

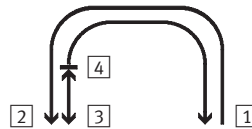

Note
When used in combination with the wait position module, the handling module HSP must be actuated using a 5/3-way valve (normally pressurised). The actuating cylinder is actuated using a 5/2-way valve. The actuating cylinder may only be used for "pulling" applications.

| Size | HSP-12 | HSP-16 | HSP-25 |
|---------------------------------------|--------|--------|--------|
| Max. Z stroke of wait position module | 15 | 25 | 25 |

Mounting options

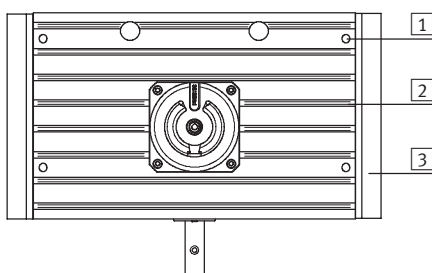

- 1 Direct mounting via through-holes
- 2 Via slot nuts
- 3 User-specific

Examples:

With adapter kit HMBV

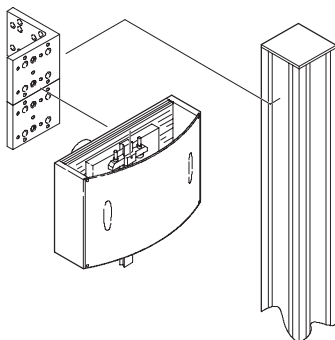

User-specific

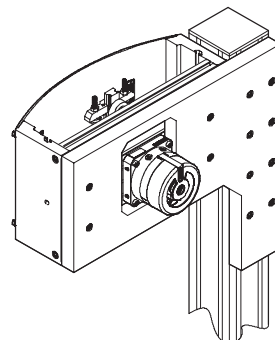

Handling modules HSP, pneumatic

Technical data

FESTO

Materials

Sectional view of handling module HSP

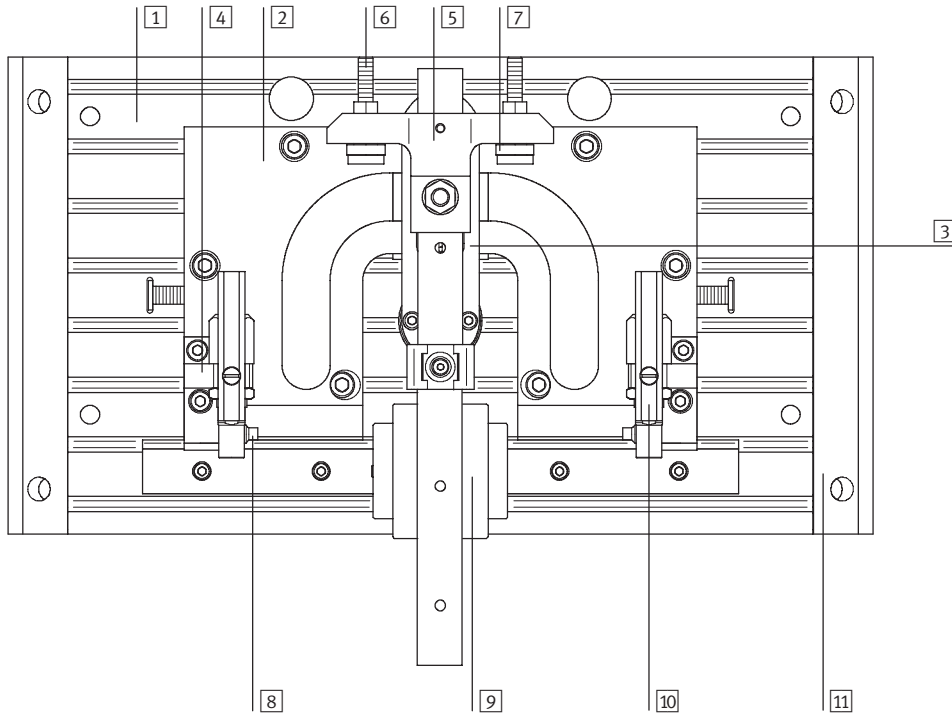

| Handling module | | |
|-----------------|---------------------|-----------------------------------|
| 1 | Back plate | Wrought aluminium alloy, anodised |
| 2 | Slotted guide plate | Case-hardened steel, burnished |
| 3 | Swivel lever | Case-hardened steel, burnished |
| 4 | Retainer | Wrought aluminium alloy, anodised |
| 5 | Flange | Wrought aluminium alloy, anodised |
| 6 | Adjusting screw | High-alloy steel |
| 7 | Stop sleeve | High-alloy steel |
| 8 | Pressure piece | High-alloy steel |
| 9 | Cross-guide | Tempered steel |
| 10 | Sensor rail | Wrought aluminium alloy, anodised |
| 11 | Housing | Wrought aluminium alloy, anodised |
| Material note | | Copper, PTFE and silicone-free |

Handling modules HSP, pneumatic

Technical data

Materials

Sectional view of swivel module DSM

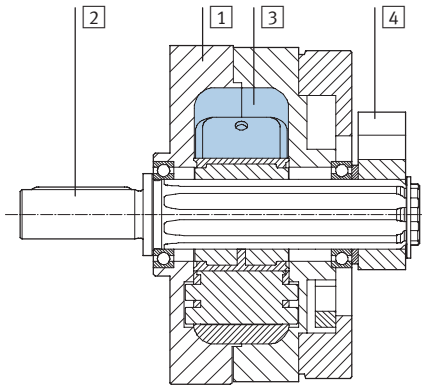

| Swivel module | | |
|---------------|---------------|----------------------------------|
| 1 | Housing | Wrought aluminium alloy |
| 2 | Shaft | Steel with nickel-plated surface |
| 3 | Rotary vane | Fibreglass reinforced plastic |
| 4 | Stop lever | Anodised aluminium |
| - | Cap | Fibreglass reinforced plastic |
| - | Seals | Polyurethane |
| - | Material note | Copper, PTFE and silicone-free |

Handling modules HSP, pneumatic

Technical data

FESTO

Dimensions

Download CAD data → www.festo.com

With swivel module DSM

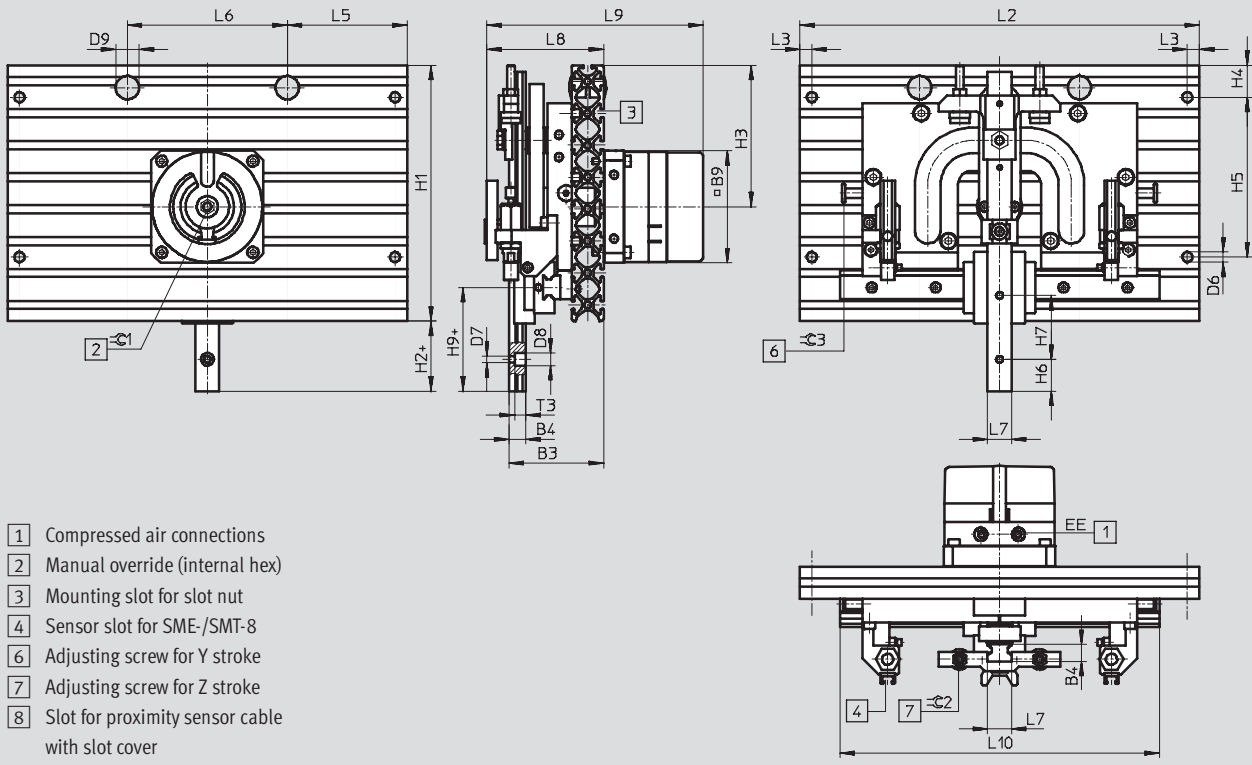

With swivel module DSM and protective cover

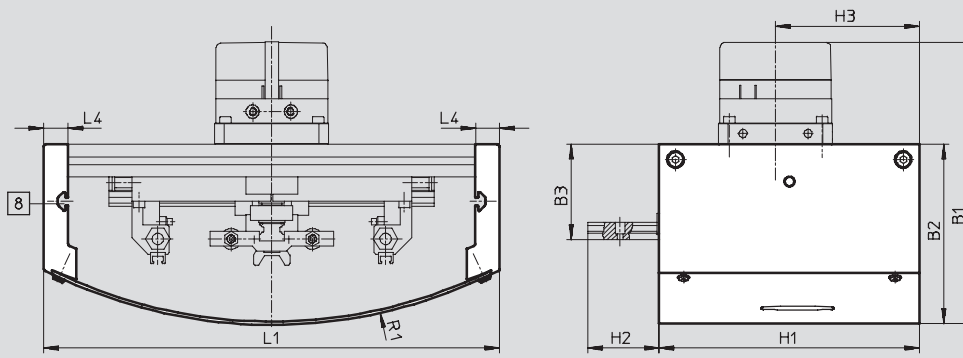

With wait position on right

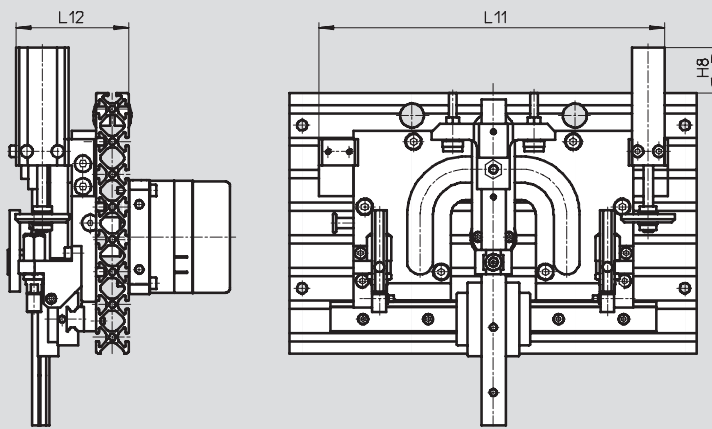

Handling modules HSP, pneumatic

Technical data

FESTO

| Size | B1 ±3 | B2 ±2 | B3 ±0.5 | B4 | B9 | D6 ∅ | D7 ∅ | D8 ∅ | D9 ∅ |
|------|----------|----------|------------|------------|----|---------|---------|---------|---------|
| 12 | 150 | 93 | 56 | 9 -0.03 | 56 | 6.3 | 3.5 | 6.2 | 13 |
| 16 | 179 | 111 | 60 | 10.6 -0.03 | 70 | 6.3 | 4.3 | 8 | 13 |
| 25 | 188 | 115 | 62 | 10 ±0.05 | 83 | 6.3 | 4.5 | 10 | 13 |

| Size | EE | H1 | H2 ±0.2 | H3 | H4 | H5 ±0.2 | H6 | H7 | H8 |
|------|----|-----|------------|------|----|------------|------|----|----|
| 12 | M5 | 120 | 34 | 66 | 40 | 40 | 12.5 | 25 | 30 |
| 16 | M5 | 160 | 44 | 88.5 | 20 | 100 | 20 | 40 | 33 |
| 25 | M5 | 200 | 75 | 110 | 40 | 100 | 20 | 30 | 13 |

| Size | H9 | L1 ±0.6 | L2 ±0.2 | L3 | L4 | L5 | L6 | L7 | L8 ±1.2 |
|------|-----|------------|------------|-----|----|----|-----|----------------|------------|
| 12 | 44 | 200 | 170 | 7.5 | 15 | 85 | - | 12 -0.01/-0.05 | 65 |
| 16 | 65 | 280 | 250 | 7.5 | 15 | 75 | 100 | 15 -0.01/-0.05 | 73 |
| 25 | 101 | 370 | 340 | 7.5 | 15 | 30 | 280 | 23.2 ±0.05 | 80 |

| Size | L9 ±3 | L10 | L11 ¹⁾ | L12 | R1 | T3 | ≈C1 | ≈C2 | ≈C3 |
|------|----------|-----|-------------------|-----|-----|-----|-----|-----|-----|
| 12 | 122 | 150 | 141.5 | 64 | 200 | 6 | 6 | 2 | 3 |
| 16 | 142 | 200 | 210 | 69 | 306 | 6.5 | 8 | 2.5 | 3 |
| 25 | 153 | 250 | 277 | 79 | 484 | 6.3 | 8 | 2.5 | 4 |

1) If the Y stroke is increased, the change in stroke must be added to the dimension.

| Ordering data for HSP-...-AP | | | | | | | | | |
|------------------------------|----------|-----------------|----------|-----------------|----------|-----------------|--|--|--|
| Size | 12 | | 16 | | 25 | | | | |
| | Part No. | Type | Part No. | Type | Part No. | Type | | | |
| Without protective cover | | | | | | | | | |
| - | 533 599 | HSP-12-AP | 533 607 | HSP-16-AP | 533 615 | HSP-25-AP | | | |
| Wait position on right | 533 603 | HSP-12-AP-WR | 533 611 | HSP-16-AP-WR | 533 619 | HSP-25-AP-WR | | | |
| Wait position on left | 533 604 | HSP-12-AP-WL | 533 612 | HSP-16-AP-WL | 533 620 | HSP-25-AP-WL | | | |
| With protective cover | | | | | | | | | |
| - | 533 600 | HSP-12-AP-SD | 533 608 | HSP-16-AP-SD | 533 616 | HSP-25-AP-SD | | | |
| Wait position on right | 533 601 | HSP-12-AP-SD-WR | 533 609 | HSP-16-AP-SD-WR | 533 617 | HSP-25-AP-SD-WR | | | |
| Wait position on left | 533 602 | HSP-12-AP-SD-WL | 533 610 | HSP-16-AP-SD-WL | 533 618 | HSP-25-AP-SD-WL | | | |

Handling modules HSP, electric

Type codes

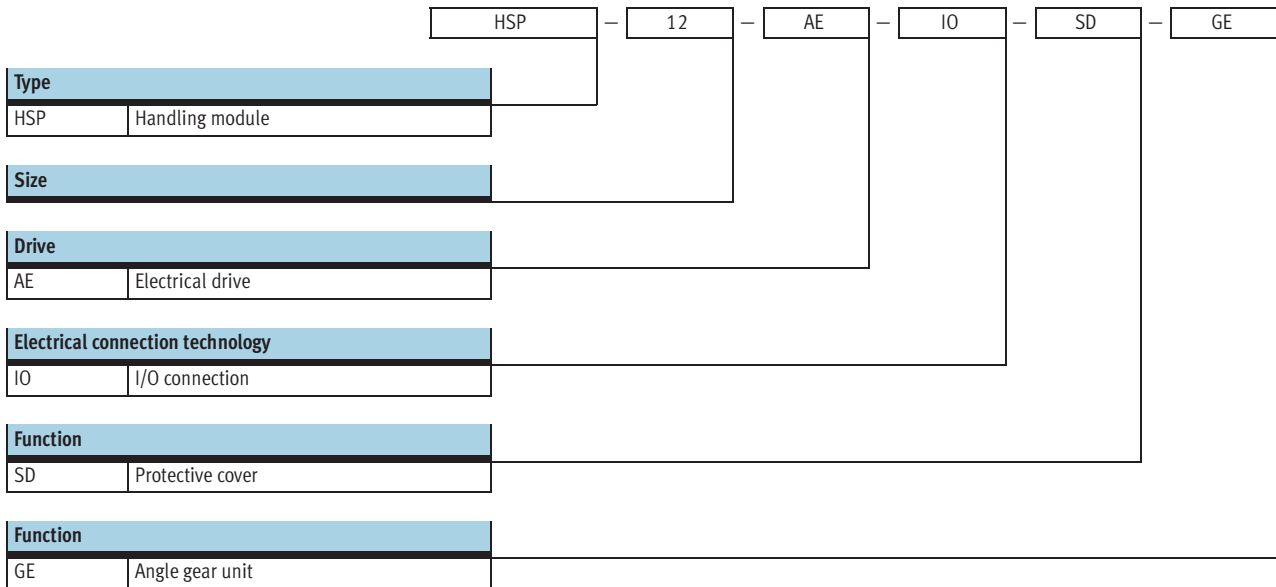

Handling modules HSP, electric

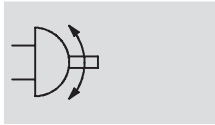

Technical data

Function



 www.festo.com



-  Diameter
12, 16 and 25
-  Y-stroke length
52 ... 170
-  Z-stroke length
20 ... 70

| General technical data | |
|------------------------|---------------------------------|
| Type | HSP-...-AE |
| Constructional design | Motor unit |
| | Cross-guide |
| | Guided motion sequence |
| Cushioning | Noise reduction via buffers |
| Type of mounting | With through-holes |
| | With slot nuts |
| Mounting position | Guide rail, vertical/horizontal |

| Operating and environmental conditions | |
|---|-------------------------------------|
| Type | HSP-...-AE |
| Ambient temperature [°C] | 0 ... +50 |
| Protection class handling module | IP40 |
| Protection class motor | IP54 |
| CE marking (see declaration of conformity) | In accordance with EU EMC directive |

| Stroke [mm] | | | | |
|----------------|-----------|------------|-------------|-----------|
| Size | 12 | 16 | 25 | |
| Y-axis | | | | |
| Stroke | 52 ... 68 | 90 ... 110 | 130 ... 170 | |
| Z-axis | | | | |
| Stroke | Z | 20 ... 30 | 35 ... 50 | 50 ... 70 |
| Working stroke | Za | 5 ... 15 | 5 ... 20 | 5 ... 25 |

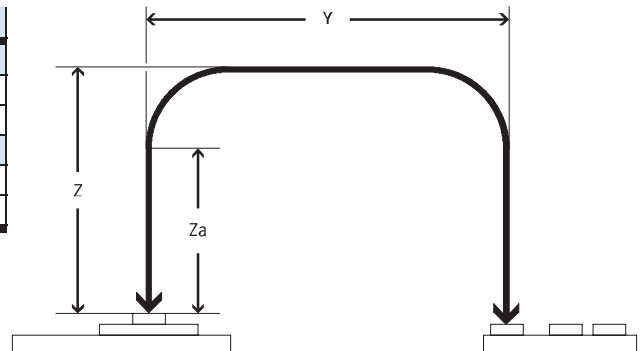

| Forces [N] | | | | | | |
|---|----|----|----|-----|-----|-----|
| Size | 12 | | 16 | | 25 | |
| Stroke [mm] | 52 | 68 | 90 | 110 | 130 | 170 |
| Z-axis | | | | | | |
| Effective force at 40% of drive torque (preset) | 10 | | 10 | | 15 | |
| Max. effective force relative to stroke | 22 | 17 | 24 | 20 | 48 | 36 |
| Y-axis | | | | | | |
| Permissible process force | 30 | | 35 | | 50 | |

Handling modules HSP, electric

Technical data



| Weight [g] | | | |
|------------------|------|------|-------|
| Size | 12 | 16 | 25 |
| HSP-...-AE | 3700 | 5300 | 9000 |
| HSP-...-AE-SD | 4500 | 6600 | 10700 |
| HSP-...-AE-GE | 4000 | 5700 | 10100 |
| HSP-...-AE-SD-GE | 4800 | 7000 | 11800 |

Repetition accuracy [mm]

To ensure low-vibration operation, the working load should be mounted as close as possible to the guide rail of the handling module. Repetition accuracy is guaranteed by

mounting the working load (adapter plate, rotary drive and/or gripper, gripper finger, workpiece) within the mounting surface of the adapter kit HAPG.

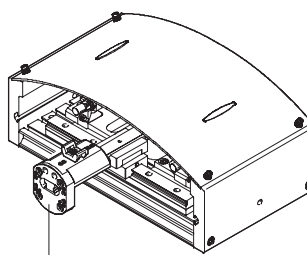

Mounting surface of HAPG

| Size | 12 | 16 | 25 | |
|---------------------|--|---------------------|---------------------|-------------------|
| Repetition accuracy | At end positions Intermediate positions | ± 0.01 < 1.5 | ± 0.01 < 1.5 | ± 0.02 < 2 |

Travel times t as a function of working load m

The travel time t is the time taken for the handling module to move from one end position to the other and back again.

The working load m is the load attached to the vertical guide rail (e.g. adapter, gripper, semi-rotary drive and workpiece)

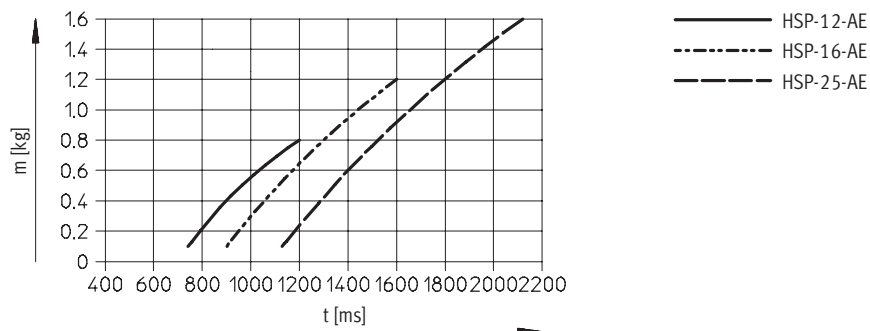

Handling modules HSP, electric

Technical data

Permissible static/dynamic characteristic load values

Cross-guide

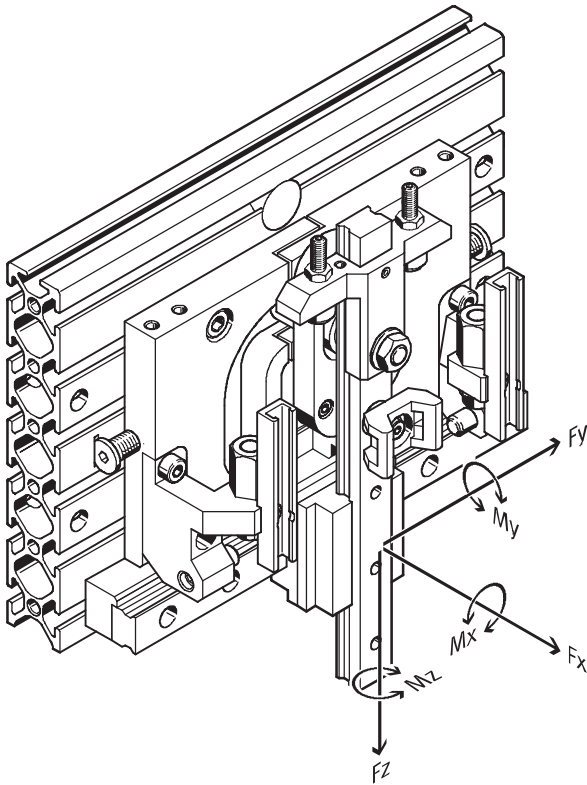

- - Note

The torques apply to the centre of the vertical guide.

Combined load

The following torque equation must be satisfied with combined load:

$$\frac{M_x}{M_{xperm.}} + \frac{M_y}{M_{yperm.}} + \frac{M_z}{M_{zperm.}} \leq 1$$

Dynamic characteristic load values

| Size | 12 | 16 | 25 |
|---|-----|-----|-----|
| Max. torques [Nm] $M_{xperm.}, M_{yperm.}, M_{zperm.}$ | 1.1 | 2.4 | 3.2 |

Combined load

The following torque equation must be satisfied with combined load:

$$\frac{M_{ox}}{M_{oxperm.}} + \frac{M_{oy}}{M_{oyperm.}} + \frac{M_{oz}}{M_{ozperm.}}$$

Static characteristic load values

| Size | 12 | 16 | 25 |
|--|----|----|----|
| Max. torques [Nm] $M_{oxperm.}, M_{oyperm.}, M_{ozperm.}$ | 5 | 10 | 15 |

Stroke adjustment

Y stroke:

- Once the HSP has been mounted, the Y strokes of the pick and place position can be set independently of each other.

Z stroke:

- Differences in height, for example between a rotary indexing table and a transfer system, can be compensated after mounting.

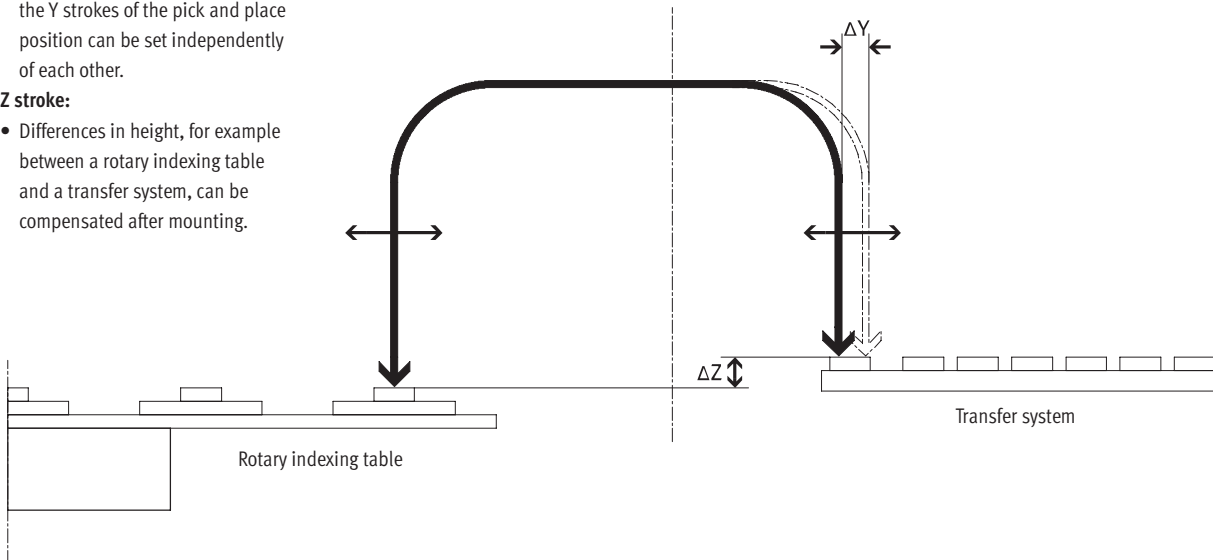

Y-axis (horizontal)

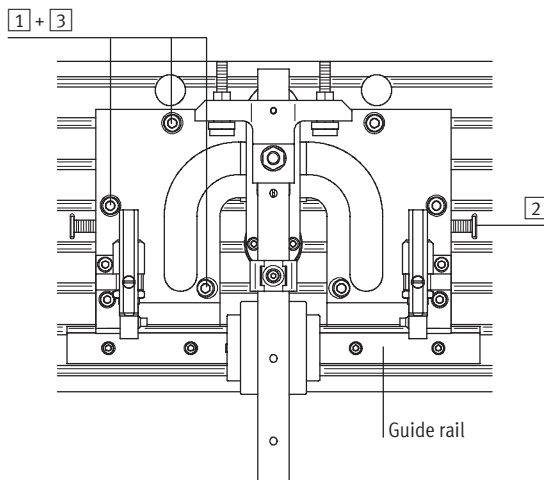

Procedure:

- Loosen the screws
- Adjust the slotted guide plate using the adjustment screw (the slotted guide plate must always make contact with the guide rail)
- Tighten the screws

Z-axis (vertical)

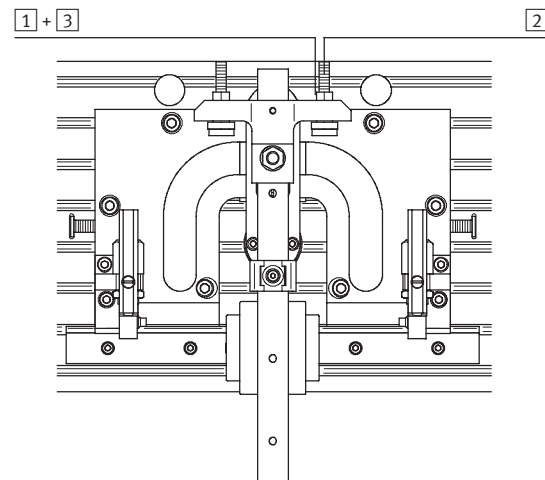

Procedure:

- Loosen the lock nut
- Set the desired Z stroke using the set screw
- Tighten the lock nut

Handling modules HSP, electric

Technical data

Materials

Sectional view

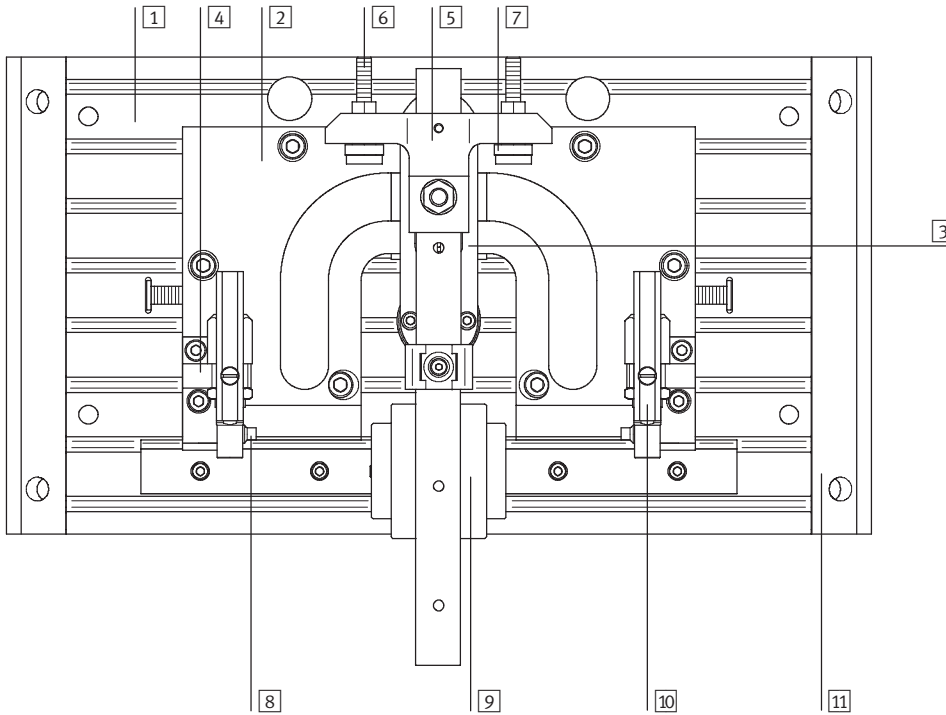

| Handling module | |
|---|---|
| 1 | Back plate Wrought aluminium alloy, anodised |
| 2 | Slotted guide plate Case-hardened steel, burnished |
| 3 | Swivel lever Case-hardened steel, burnished |
| 4 | Retainer Wrought aluminium alloy, anodised |
| 5 | Flange Wrought aluminium alloy, anodised |
| 6 | Adjusting screw High-alloy steel |
| 7 | Stop sleeve High-alloy steel |
| 8 | Pressure piece High-alloy steel |
| 9 | Cross-guide Tempered steel |
| 10 | Sensor rail Wrought aluminium alloy, anodised |
| 11 | Housing Wrought aluminium alloy, anodised |
| Material note Copper, PTFE and silicone-free | |

Handling modules HSP, electric

Technical data

FESTO

Motor mounting variants

Motor pointing upwards/to side

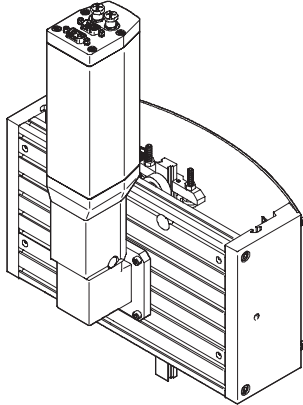

Control panel and access to the connections can be rotated according to space requirements.

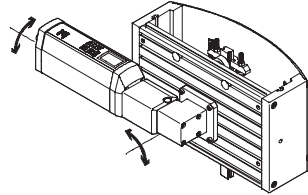

Motor towards rear

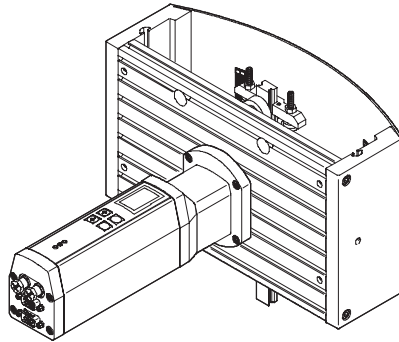

Mounting options

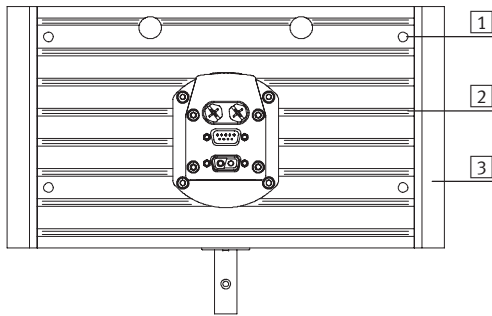

- 1 Direct mounting via through-holes
- 2 Via slot nuts
- 3 User-specific

Examples:

With adapter kit HMBV

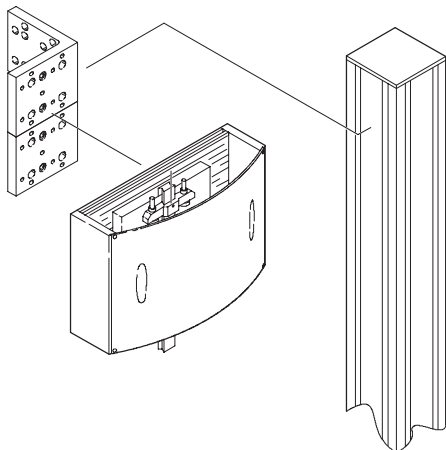

User-specific

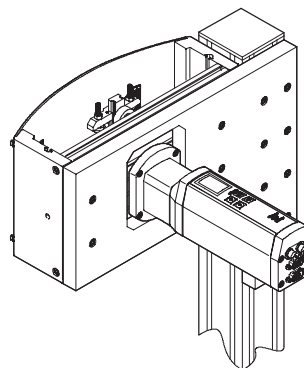

Handling modules HSP, electric

Technical data

FESTO

Servo-motor unit MTR-DCI-...-HM



| General technical data | | → Internet: mtr-dci |
|------------------------------|--|-----------------------|
| Type | MTR-DCI-... | |
| for handling module | HSP-12-AE | HSP-16/25-AE |
| Rotary position generator | Optical encoder | |
| No. of increments/revolution | 500 | |
| Temperature monitoring | Silicon absolute temperature sensor, switches off at temperatures >70 °C | |
| Display resolution | 128 x 64 pixels | |
| Type of mounting | Can be screwed on or clamped to gearing flange | |
| Gearing type | Planetary gear unit | |
| Gear unit ratio | 6.752 (7:1); 1-stage | 13.73 (14:1); 2-stage |

| Electrical data | | → Internet: mtr-dci | |
|--|------------------|---------------------|---------|
| Type | MTR-DCI-42-HM | MTR-DCI-52-HM | |
| for handling module | HSP-12/16-AE | HSP-25-AE | |
| Nominal voltage | [V DC] | 24 ±10% | 24 ±10% |
| Nominal current (motor) | [A] | 2 | 5.1 |
| Peak current | [A] | 3.8 | 7.7 |
| Nominal power (motor) | [W] | 48 | 122.4 |
| Max. current (digital logic outputs) | [mA] | 200 | 60 |
| No. of digital logic inputs (with I/O connection) | - | 6 | |
| No. of digital logic outputs (with I/O connection) | - | 2 | |
| Parameterisation interface | RS232, 9600 baud | | |

| Pin allocation | | | | | |
|----------------|---------------------------|--|--|-----------------------------------|--|
| | 1 3-pin M8 socket | | 2 RS 232 interface, 4-pin M8 socket | | |
| | Pin | Function | Pin | Function | |
| | 1 | Unused | 1 | 0 V | |
| | 3 | Unused | 2 | Transmitted Data (TxD) | |
| | | 4 | Received Data (RxD) | | |
| | | | 4 | - | |
| | | 3 I/O interface, 9-pin SUB-D plug | | 4 Power supply, 2-pin plug | |
| Pin | Function | Pin | Function | | |
| 1 | Travel time coding, bit 0 | 1 | 24 V DC | | |
| 2 | Travel time coding, bit 1 | 2 | 0 V | | |
| 3 | Travel time coding, bit 2 | - | | | |
| 4 | Travel time coding, bit 3 | - | | | |
| 5 | Start bit | - | | | |
| 6 | Enable bit | - | | | |
| 7 | Ready signal output | - | | | |
| 8 | MC signal output | - | | | |
| 9 | 0 V | - | | | |

Handling modules HSP, electric

Technical data



Simple solution for your application

Advantages of handling module HSP-...-AE – Installation and commissioning

- Handling module is supplied with motor already attached.
- Less wiring required thanks to integration of controller concept.
- Motor with gear unit, controller and power electronics are all fitted in one housing. This means that only one unit has to be taken into consideration when planning the system.
- Only one voltage supply of 24 V is required for commissioning.
- Commissioning via:
 - control panel on handling module
 - PC using FESTO Configuration Tool (FCT) software

Installation and commissioning

Step 1: Mount the handling module

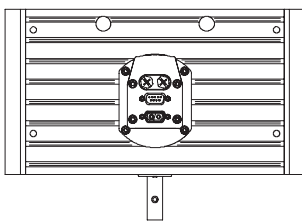

- Wide choice of mounting options

→ 24

Step 2: Mechanically adjust the end positions

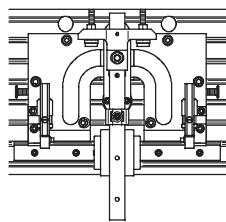

- End positions of strokes along Y- and Z-axes can be adjusted independently of each other

→ 22

Step 3: Connect the 24 V voltage supply

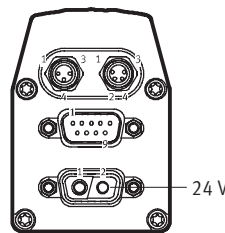

- Plug and work: Connect voltage – HSP is ready for operation

→ 25

Step 4: Parameterisation either via control panel on motor or using FCT software
Control panel on motor

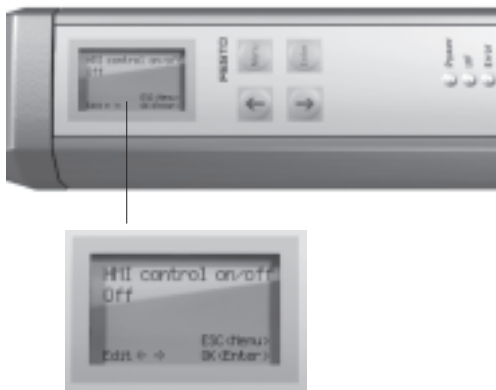

- Clearly arranged LCD display
- All data is entered and saved using 4 keys:
 - menu key
 - arrow keys for changing parameter values or traversing records
 - key for confirming the entered actions

FCT software – Festo Configuration Tool

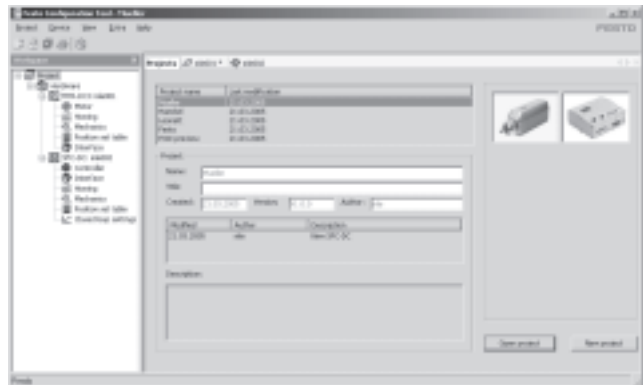

- All the drives in a system can be managed and archived in the common project
- Project and data management for all supported device types
- Simple to use thanks to graphically supported parameter entry
- Universal mode of operation for all drives
- Working offline at your desk or online at the machine

Handling modules HSP, electric

Technical data

Step 5: Selection of predefined motion sequences (HSP mode) via the control panel or using the FCT software

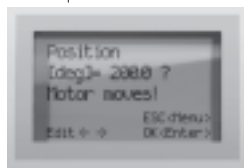

HSP mode 1



- Precise travel to the mechanical end position

HSP mode 2

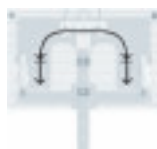

- Additional adjustable wait position module directly above workpiece/ workpiece carrier
- Handling of parts with different heights
- Insertion procedures at different speeds

HSP mode 3



- Additional ejector station for reject parts or quality inspection
- Precise travel to end position with setup position

HSP mode 4



- Insertion procedures with defined force
- Continued travel from wait position with adjustable torque

HSP mode 5

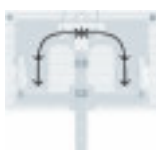

- Insertion procedures with defined force and additional intermediate position
- Continued travel from wait position with adjustable torque

Step 6: Fine adjustment

- Adjustment of preset positions, speeds and torques
- Addition of new traversing records (where necessary)

Handling modules HSP, electric

Technical data

FESTO

Dimensions

Download CAD data → www.festo.com

With motor unit pointing upwards

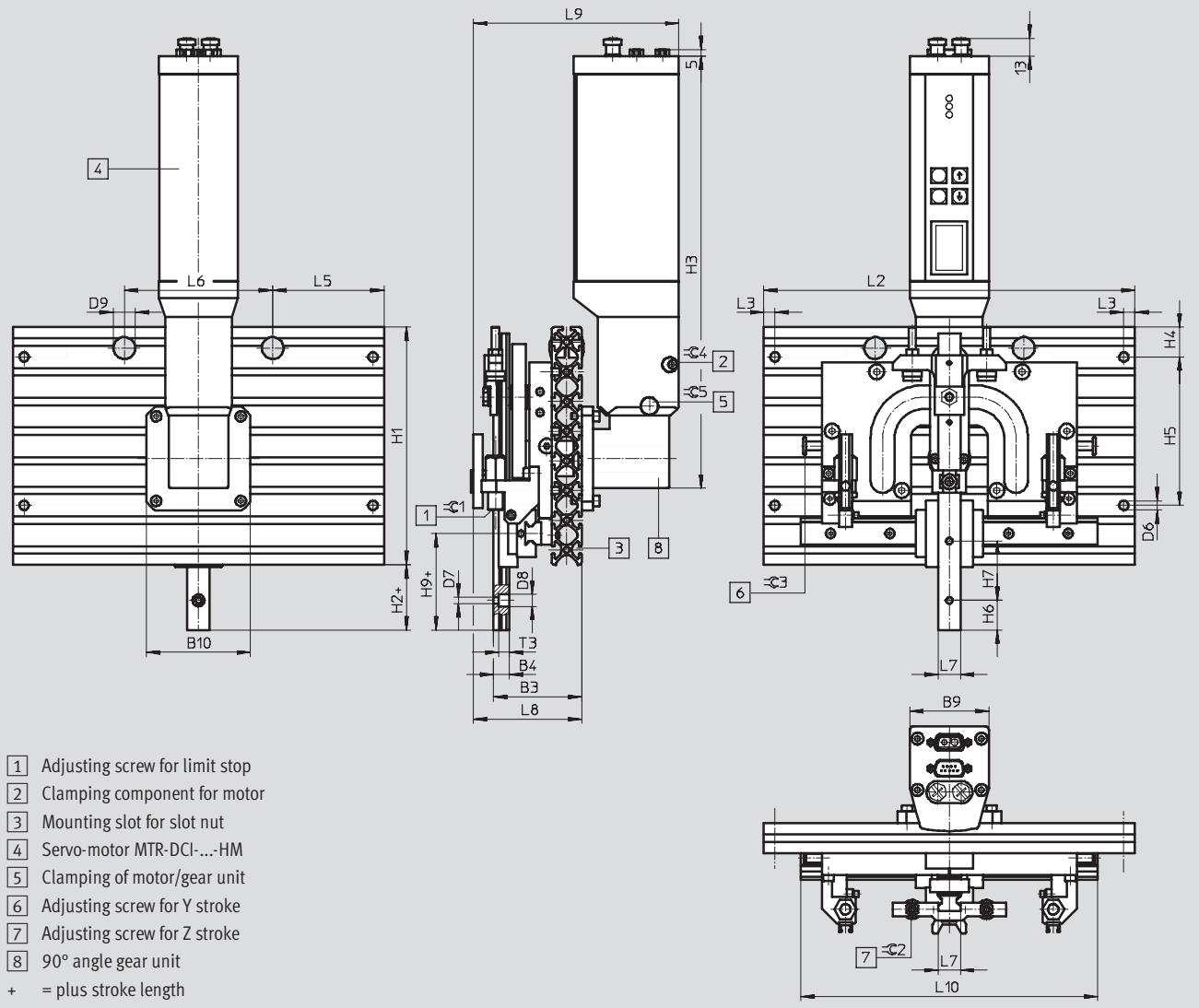

With motor unit pointing sideways

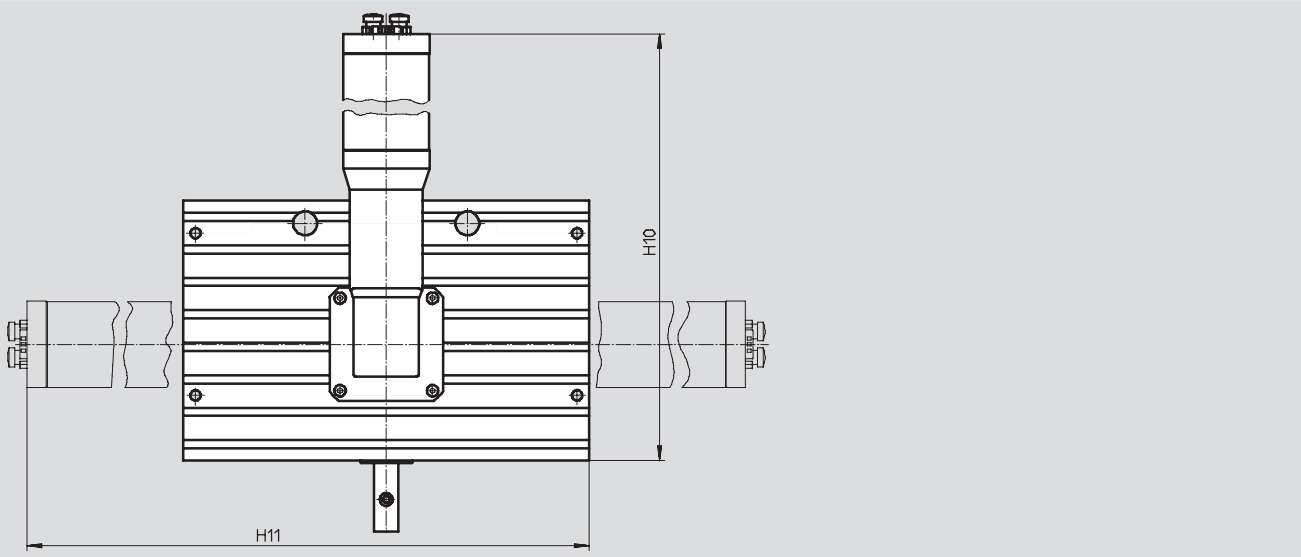

Handling modules HSP, electric

Technical data

FESTO

Dimensions

Download CAD data → www.festo.com

With motor unit pointing upwards and protective cover

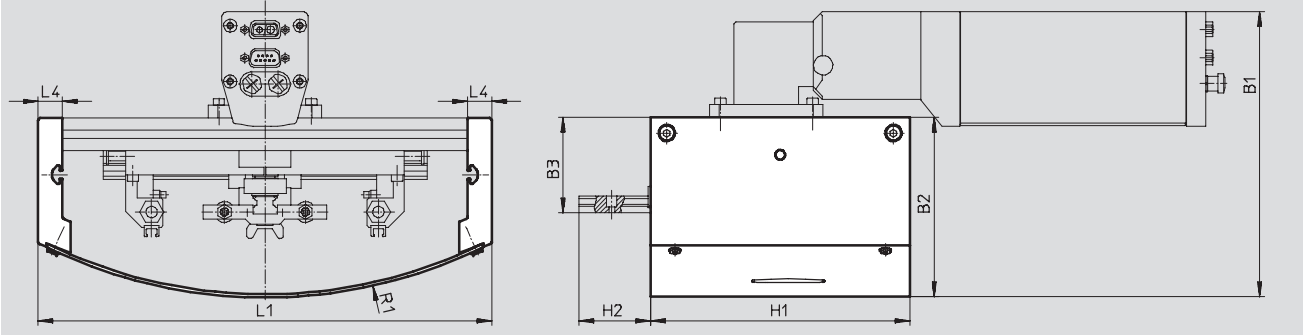

| Size | B1 ±3 | B2 ±2 | B3 ±0.5 | B4 | B9 | B10 | D6 ∅ | D7 ∅ | D8 ∅ |
|------|----------|----------|------------|-----------------------|------|-----|---------|---------|---------|
| 12 | 159 | 93 | 56 | 9 ^{-0.03} | 53.3 | 59 | 6.3 | 3.5 | 6.2 |
| 16 | 178 | 111 | 60 | 10.6 ^{-0.03} | 53.3 | 70 | 6.3 | 4.3 | 8 |
| 25 | 203 | 115 | 62 | 10 ^{±0.05} | 69.5 | 100 | 6.3 | 4.5 | 10 |

| Size | D9 ∅ | H1 | H2 ±0.2 | H3 | H4 | H5 ±0.2 | H6 | H7 | H9 | H10 |
|------|---------|-----|------------|-----|----|------------|------|----|-----|-----|
| 12 | 13 | 120 | 34 | 278 | 40 | 40 | 12.5 | 25 | 44 | 312 |
| 16 | 13 | 160 | 44 | 291 | 20 | 100 | 20 | 40 | 65 | 343 |
| 25 | 13 | 200 | 75 | 321 | 40 | 100 | 20 | 30 | 101 | 391 |

| Size | H11 | L1 ±0.6 | L2 ±0.2 | L3 | L4 | L5 | L6 | L7 | L8 ±1.2 |
|------|-----|------------|------------|-----|----|----|-----|---------------------------|------------|
| 12 | 344 | 200 | 170 | 7.5 | 15 | 85 | – | 12 ^{-0.01/-0.05} | 65 |
| 16 | 397 | 280 | 250 | 7.5 | 15 | 75 | 100 | 15 ^{-0.01/-0.05} | 73 |
| 25 | 485 | 370 | 340 | 7.5 | 15 | 30 | 280 | 23.2 ^{±0.05} | 80 |

| Size | L9 ±3 | L10 | R1 | T3 | ≈C1 | ≈C2 | ≈C3 | ≈C4 | ≈C5 | Woodruff key to DIN 6885 ¹⁾ |
|------|----------|-----|-----|-----|-----|-----|-----|-----|-----|--|
| 12 | 118 | 150 | 200 | 6 | 2.5 | 2 | 3 | 2.5 | 2.5 | A2x2x12 |
| 16 | 136 | 200 | 306 | 6.5 | 3 | 2.5 | 3 | 2.5 | 2.5 | A3x3x18 |
| 25 | 136 | 250 | 484 | 6.3 | 3 | 2.5 | 4 | 5 | 3 | A4x4x25 |

1) included in scope of delivery

Handling modules HSP, electric

Technical data

FESTO

Dimensions

Download CAD data → www.festo.com

With motor unit towards the rear

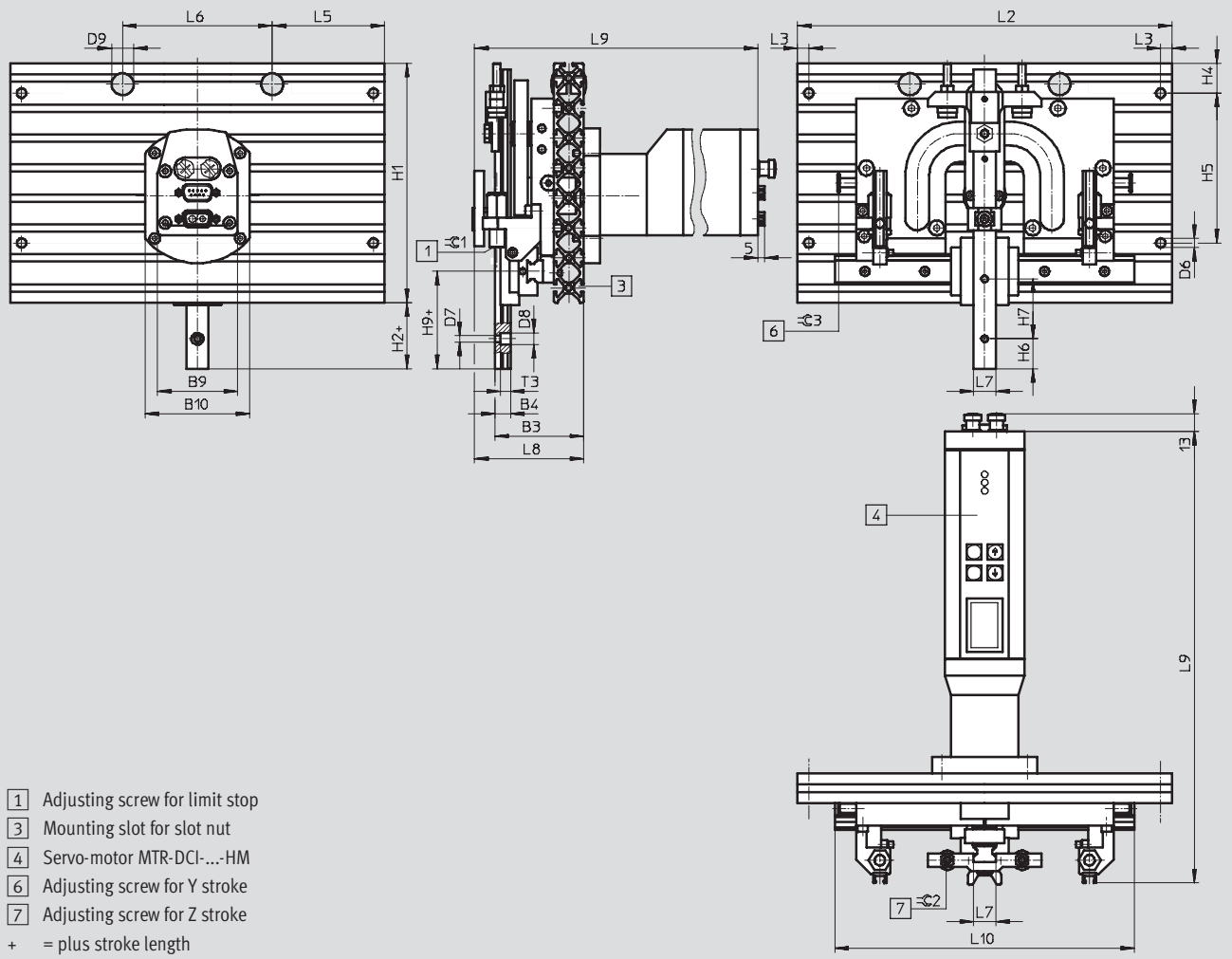

With motor unit towards the rear and protective cover

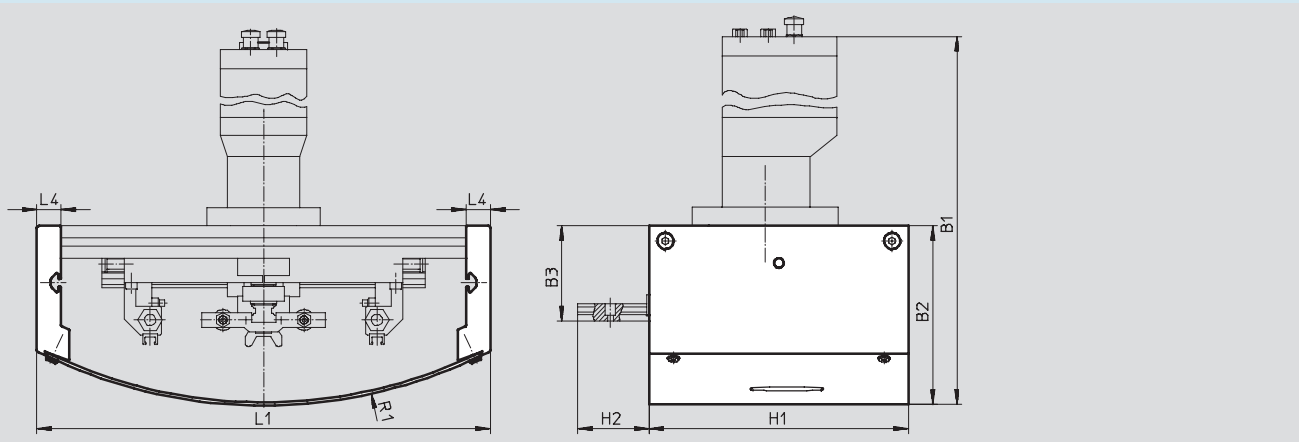

Handling modules HSP, electric

Technical data

| Size | B1 ±3 | B2 ±2 | B3 ±0.5 | B4 | B9 | B10 | D6 ∅ | D7 ∅ |
|------|----------|----------|------------|-----------------------|------|-----|---------|---------|
| 12 | 308 | 93 | 56 | 9 ^{-0.03} | 53.3 | 71 | 6.3 | 3.5 |
| 16 | 339 | 111 | 60 | 10.6 ^{-0.03} | 53.3 | 70 | 6.3 | 4.3 |
| 25 | 372 | 115 | 62 | 10 ^{±0.05} | 69.5 | 90 | 6.3 | 4.5 |

| Size | D8 ∅ | D9 ∅ | H1 | H2 ±0.2 | H4 | H5 ±0.2 | H6 | H7 |
|------|---------|---------|-----|------------|----|------------|------|----|
| 12 | 6.2 | 13 | 120 | 34 | 40 | 40 | 12.5 | 25 |
| 16 | 8 | 13 | 160 | 44 | 20 | 100 | 20 | 40 |
| 25 | 10 | 13 | 200 | 75 | 40 | 100 | 20 | 30 |

| Size | H9 | L1 ±0.6 | L2 ±0.2 | L3 | L4 | L5 | L6 | L7 |
|------|-----|------------|------------|-----|----|----|-----|---------------------------|
| 12 | 44 | 200 | 170 | 7.5 | 15 | 85 | - | 12 ^{-0.01/-0.05} |
| 16 | 65 | 280 | 250 | 7.5 | 15 | 75 | 100 | 15 ^{-0.01/-0.05} |
| 25 | 101 | 370 | 340 | 7.5 | 15 | 30 | 280 | 23.2 ^{±0.05} |

| Size | L8 ±1.2 | L9 ±3 | L10 | R1 | T3 | ≈C1 | ≈C2 | ≈C3 |
|------|------------|----------|-----|-----|-----|-----|-----|-----|
| 12 | 65 | 280 | 150 | 200 | 6 | 6 | 2 | 3 |
| 16 | 73 | 301 | 200 | 306 | 6.5 | 8 | 2.5 | 3 |
| 25 | 80 | 337 | 250 | 484 | 6.3 | 8 | 2.5 | 4 |

| Ordering data for HSP-... AE | | | | | | | | |
|------------------------------|----------|--------------------|--|----------|--------------------|--|----------|--------------------|
| Size | 12 | | | 16 | | | 25 | |
| | Part No. | Type | | Part No. | Type | | Part No. | Type |
| I/O connection | | | | | | | | |
| Without gear unit | | | | | | | | |
| Without protective cover | 539 536 | HSP-12-AE-IO | | 539 544 | HSP-16-AE-IO | | 539 552 | HSP-25-AE-IO |
| With protective cover | 539 538 | HSP-12-AE-IO-SD | | 539 546 | HSP-16-AE-IO-SD | | 539 554 | HSP-25-AE-IO-SD |
| With angle gear unit | | | | | | | | |
| Without protective cover | 539 537 | HSP-12-AE-IO-GE | | 539 545 | HSP-16-AE-IO-GE | | 539 553 | HSP-25-AE-IO-GE |
| With protective cover | 539 539 | HSP-12-AE-IO-SD-GE | | 539 547 | HSP-16-AE-IO-SD-GE | | 539 555 | HSP-25-AE-IO-SD-GE |

Handling modules HSP, without drive

Type codes

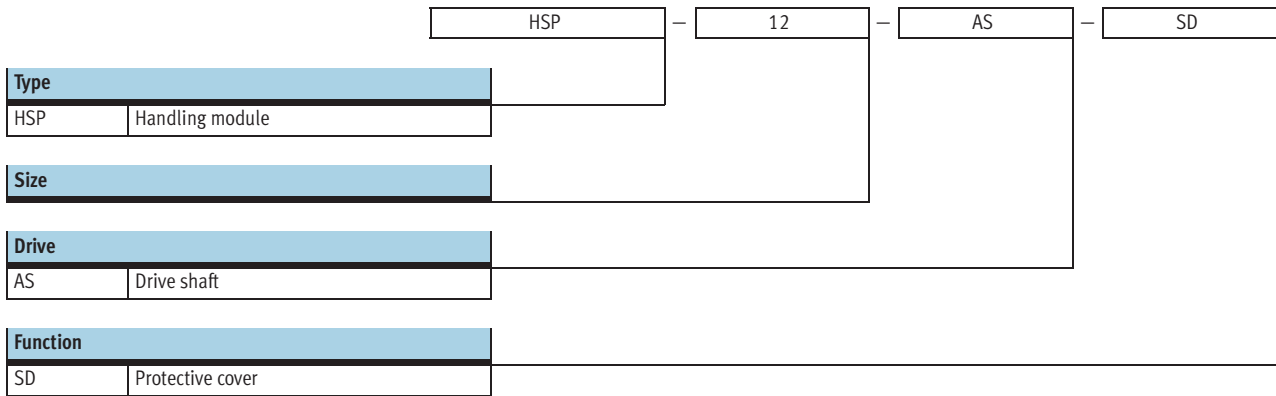

Handling modules HSP, without drive

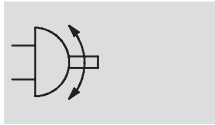

Technical data

Function



 www.festo.com





-  - Diameter
12, 16 and 25
-  - Y-stroke length
52 ... 170
-  - Z-stroke length
20 ... 70

| General technical data | |
|------------------------|---------------------------------|
| Type | HSP-...-AS |
| Constructional design | Drive shaft |
| | Cross-guide |
| | Guided motion sequence |
| Cushioning | Noise reduction via buffers |
| Type of mounting | With through-holes |
| | With slot nuts |
| Mounting position | Guide rail, vertical/horizontal |

| Weight [g] | | | |
|---------------|------|------|------|
| Size | 12 | 16 | 25 |
| HSP-...-AS | 1800 | 2700 | 6200 |
| HSP-...-AS-SD | 2500 | 3200 | 7400 |

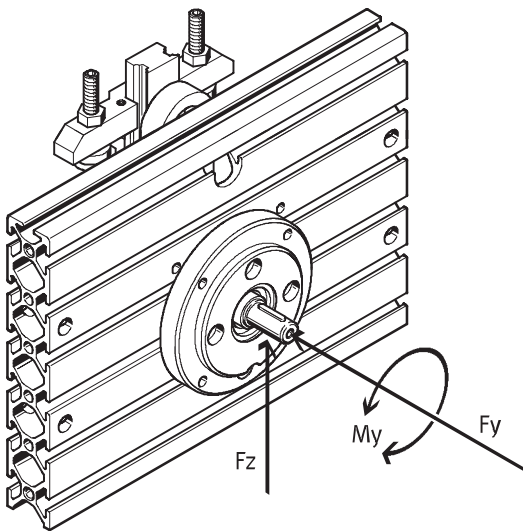
Permissible static/dynamic characteristic load values



 Note
Technical data for mechanical components → 21.

| Characteristic load values | | | |
|--------------------------------|-----------|-----|-----|
| Size | 12 | 16 | 25 |
| Max. axial force $F_{Yperm.}$ | [N] 18 | 30 | 50 |
| Max. radial force $F_{Zperm.}$ | [N] 45 | 75 | 120 |
| Max. drive torque $M_{Yperm.}$ | [Nm] 1.25 | 2.5 | 5 |

Handling modules HSP, without drive

Technical data

FESTO

Mass moment of inertia J_0 as a function of working load m (for cylinder sizing)

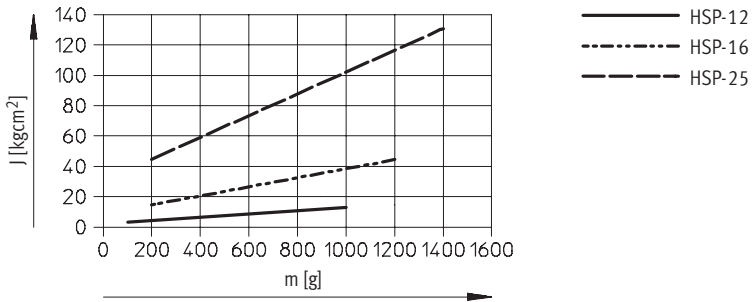

Dimensions

Download CAD data → www.festo.com

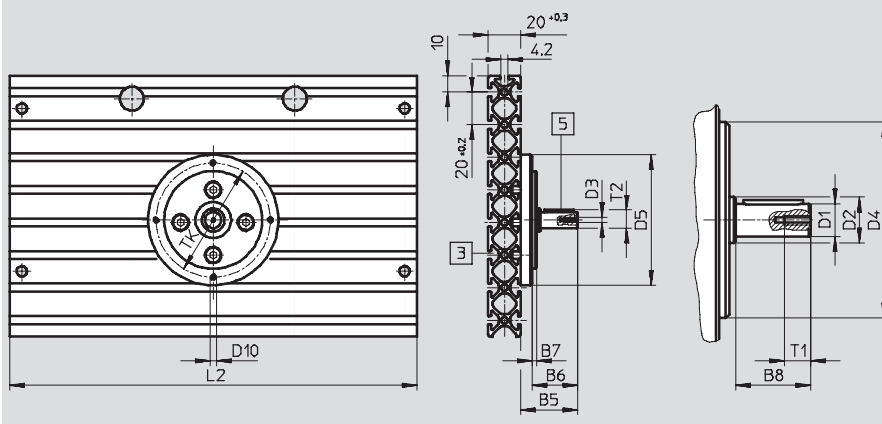

Basic dimensions

→ 28

- 3 Mounting slot for slot nut
- 5 Woodruff key

| Size | B5 | B6 | B7 | B8 | D1 ∅ g7 | D2 ∅ | D3 |
|------|----|----|----|------|---------------|---------|----|
| 12 | 29 | 22 | 3 | 17.5 | 8 | 12.5 | M3 |
| 16 | 35 | 28 | 3 | 23 | 10 | 14 | M3 |
| 25 | 44 | 36 | 4 | 30 | 12 | 17 | M4 |

| Size | D4 ∅ f8 | D5 ∅ | D10 | L2 ±0.2 | T1 | T2 max. | TK ±0.1 |
|------|---------------|---------|-----|------------|----|------------|------------|
| 12 | 45 | 65 | M4 | 170 | 9 | 8.8 | 55 |
| 16 | 60 | 80 | M4 | 250 | 9 | 11.2 | 70 |
| 25 | 70 | 95 | M5 | 340 | 10 | 13.5 | 82 |

Handling modules HSP, without drive

Technical data

| Ordering data for HSP-... AS | | | | | | |
|------------------------------|----------|--------------|----------|--------------|----------|--------------|
| Size | 12 | | 16 | | 25 | |
| | Part No. | Type | Part No. | Type | Part No. | Type |
| Without protective cover | 533 605 | HSP-12-AS | 533 613 | HSP-16-AS | 533 621 | HSP-25-AS |
| With protective cover | 533 606 | HSP-12-AS-SD | 533 614 | HSP-16-AS-SD | 533 622 | HSP-25-AS-SD |

Handling modules HSP

Accessories



Adapter kit HAPG-B

Material:
Wrought aluminium alloy, anodised

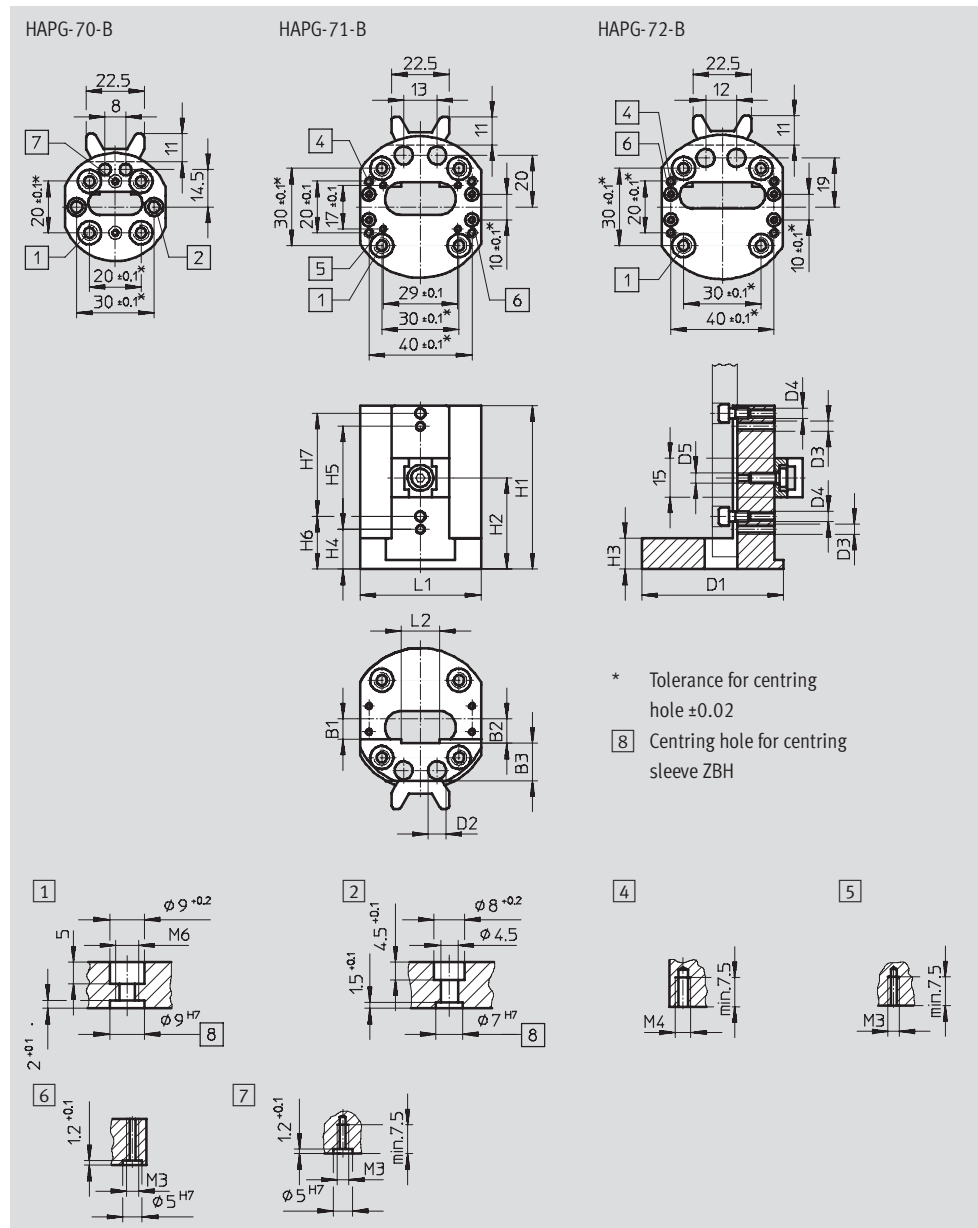

| Dimensions and ordering data | | | | | | | | | | |
|------------------------------|----|-----|------|------------------|-----|----|----|----|------|------|
| Type | B1 | B2 | B3 | D1 | D2 | D3 | D4 | D5 | H1 | H2 |
| HAPG-70-B | 5 | 6 | 11.5 | \varnothing 42 | 4.5 | - | M3 | M4 | 50 | 28.5 |
| HAPG-71-B | 8 | 9.5 | 14.5 | \varnothing 56 | 7 | M4 | M4 | M4 | 63.5 | 35.5 |
| HAPG-72-B | 8 | 9.5 | 15 | \varnothing 56 | 7 | - | M4 | M4 | 60 | 41.5 |

| Type | H3 | H4 | H5 | H6 | H7 | L1 | L2 | Weight | Part No. | Type |
|-----------|----|------|----|------|----|----|------|--------|----------|-----------|
| HAPG-70-B | 12 | - | - | 15 | 25 | 39 | 12 | 55 | 540 881 | HAPG-70-B |
| HAPG-71-B | 12 | 15.5 | 40 | 20.5 | 40 | 47 | 15 | 110 | 540 882 | HAPG-71-B |
| HAPG-72-B | 12 | - | - | 20.5 | 30 | 47 | 23.2 | 115 | 540 883 | HAPG-72-B |

Handling modules HSP

Accessories

Installation kit MKRP

Material:
 Conduit/fitting: Polyamide
 Reducer/lock nut:
 Nickel-plated brass
 Adapter plate/bracket:
 Powder-coated steel

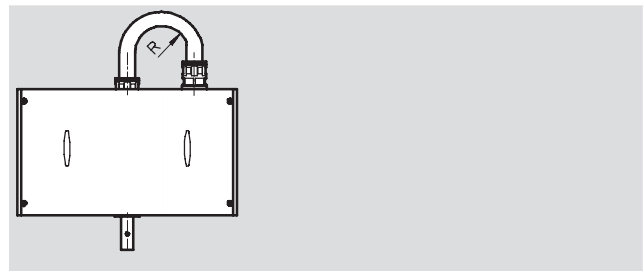

| Ordering data | | | | | |
|---------------|---|-------------|--------|----------|--------|
| For size | Max. bending radius for conduit ¹⁾ | Tubing I.D. | Weight | Part No. | Type |
| | R | [mm] | [g] | | |
| 12 | 55 | 12 | 150 | 533 632 | MKRP-1 |
| 16 | 75 | 16.5 | 160 | 533 633 | MKRP-2 |
| 25 | 75 | 16.5 | 160 | 533 634 | MKRP-3 |

1) The conduit must not be filled beyond 70%.

Cover kit BSD-HSP

Material:
 Wrought aluminium alloy, anodised



Dimensions HSP-...-AP → 16
 HSP-...-AE → 30
 HSP-...-AS → 30

| Ordering data | | | |
|---------------|--------|----------|------------|
| For size | Weight | Part No. | Type |
| | [g] | | |
| 12 | 825 | 533 635 | BSD-HSP-12 |
| 16 | 1 350 | 533 636 | BSD-HSP-16 |
| 25 | 1 770 | 533 637 | BSD-HSP-25 |

Wait position module BWL-/BWR-HSP for HSP-...-AP

Material:
 Wrought aluminium alloy, anodised



Dimensions → 16

| Ordering data | | | | |
|---------------|---------------|--------|----------|------------|
| For size | Wait position | Weight | Part No. | Type |
| | | [g] | | |
| 12 | Right | 75 | 533 623 | BWR-HSP-12 |
| | Left | 75 | 533 624 | BWL-HSP-12 |
| 16 | Right | 135 | 533 625 | BWR-HSP-16 |
| | Left | 135 | 533 626 | BWL-HSP-16 |
| 25 | Right | 275 | 533 627 | BWR-HSP-25 |
| | Left | 275 | 533 628 | BWL-HSP-25 |

Handling modules HSP

Accessories

FESTO

Adapter kits for grippers

For combining HSP with grippers HG... or semi-rotary drive DRQD

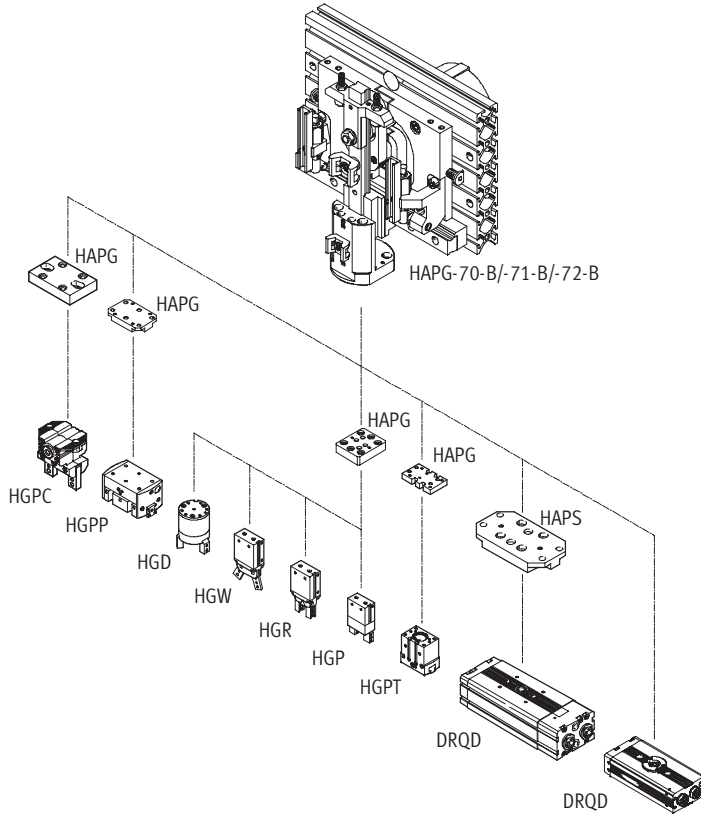

| Gripper | | Adapter kit | | Required mounting components | B1 | D1 | D2 | H1 | L1 |
|---------------------------|-------------|-------------|-----------------------|------------------------------|----|------|----|----|------|
| Part No. | Type | Part No. | Type | | | | | | |
| HSP-12-... with HAPG-70-B | | | | | | | | | |
| 174 815 | HGP-06-A | 192 709 | HAPG-60-S1 | - | 12 | M3 | M5 | 30 | 30 |
| 174 817 | HGR-10-A | | | | | | | | |
| 174 818 | HGW-10-A | | | | | | | | |
| 535 858 | HGPT-16-A | 537 169 | HAPG-75 | - | 8 | M2.5 | 3 | 27 | 49.6 |
| 1) | DRQD-6-... | - | - | M4 x 20 | - | - | - | - | - |
| HSP-16-... with HAPG-71-B | | | | | | | | | |
| 174 815 | HGP-06-A | 192 706 | HAPG-37-S1 | - | 12 | M3 | M5 | 42 | 50 |
| 174 817 | HGR-10-A | | | | | | | | |
| 174 818 | HGW-10-A | | | | | | | | |
| 197 542 | HGP-10-A-B | 192 705 | HAPG-36-S1 | - | 12 | M3 | M5 | 42 | 50 |
| 174 819 | HGD-16-A | | | | 12 | M3 | M5 | 42 | 50 |
| 161 829 | HGR-16-A | | | | 12 | M3 | M5 | 42 | 50 |
| 161 833 | HGW-16-A | | | | | | | | |
| 525 658 | HGPP-10-A | 529 017 | HAPG-57 ²⁾ | - | 8 | M3 | M4 | 33 | 49.6 |
| 187 867 | HGPP-12-A | 191 900 | HAPG-54 | - | 12 | M3 | M5 | 44 | 52 |
| 535 858 | HGPT-16-A | 537 169 | HAPG-75 | - | 8 | M2.5 | 3 | 27 | 49.6 |
| 535 861 | HGPT-20-A | - | - | - | - | - | - | - | - |
| 539 269 | HGPC-16-A | 191 901 | HAPG-55 | - | 10 | M3 | M5 | 40 | 62 |
| 1) | DRQD-8-... | 178 448 | HAPS-2 ²⁾ | - | 8 | M4 | M4 | 28 | 48 |
| 1) | DRQD-12-... | - | - | - | - | - | - | - | - |

1) The semi-rotary drive DRQD is a modular product; for information on configuration and ordering, visit www.festo.com
 2) The centring sleeves for attaching to the adapter kit HAPG-71-B are not required.

Handling modules HSP

Accessories

FESTO

| Gripper | | Adapter kit | | Required mounting components | B1 | D1 | D2 | H1 | L1 |
|---------------------------|---------------|-------------|-----------------------|------------------------------|----|------|----|----|------|
| Part No. | Type | Part No. | Type | | | | | | |
| HSP-25-... with HAPG-72-B | | | | | | | | | |
| 197 542 | HGP-10-A-B | 192 705 | HAPG-36-S1 | - | 12 | M3 | M5 | 42 | 50 |
| 174 819 | HGD-16-A | | | | | | | | |
| 161 829 | HGR-16-A | | | | | | | | |
| 161 833 | HGW-16-A | | | | | | | | |
| 197 545 | HGP-16-A-B | 193 922 | HAPG-37-S4 | - | 12 | M4 | M5 | 42 | 50 |
| 161 830 | HGR-25-A | | | | | | | | |
| 161 834 | HGW-25-A | | | | | | | | |
| 525 658 | HGPP-10-A | 529 017 | HAPG-57 ²⁾ | - | 8 | M3 | M4 | 33 | 49.6 |
| 187 867 | HGPP-12-A | 191 900 | HAPG-54 | - | 12 | M3 | M5 | 44 | 52 |
| 187 870 | HGPP-16-A | 191 901 | HAPG-55 | - | 10 | M3 | M5 | 40 | 62 |
| 535 858 | HGPT-16-A | 537 169 | HAPG-75 | - | 8 | M2.5 | 3 | 27 | 49.6 |
| 535 861 | HGPT-20-A | | | | | | | | |
| 539 271 | HGPC-20-A | 191 901 | HAPG-55 | - | 10 | M3 | M5 | 40 | 62 |
| 1) | DRQD-12-... | 178 448 | HAPS-2 ²⁾ | - | 8 | M4 | M4 | 28 | 28 |
| 1) | DRQD-B-16-... | 192 707 | HAPG-38 | - | 12 | M4 | M5 | 50 | 71 |

1) The semi-rotary drive DRQD is a modular product; for information on configuration and ordering, visit www.festo.com

2) The centring sleeves for attaching to the adapter kit HAPG-71-B are not required.

Adapter kit HAPG-36/-37/-38/-60

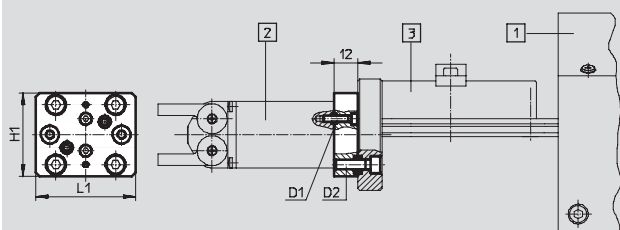

- 1 Handling module HSP
- 2 Gripper HG...
- 3 Adapter kit HAPG

Adapter kit HAPG38/-54/-55/-57

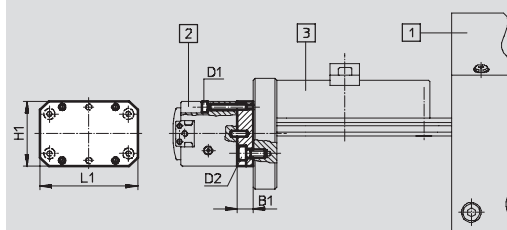

- 1 Handling module HSP
- 2 Parallel gripper HGP...
- 3 Adapter kit HAPG

Adapter kit HAPG-75

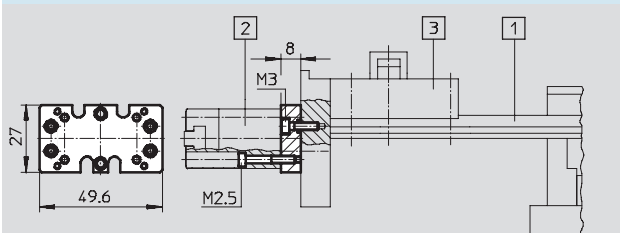

- 1 Handling module HSP
- 2 Parallel gripper HGPT
- 3 Adapter kit HAPG

Adapter kit HAPS-2

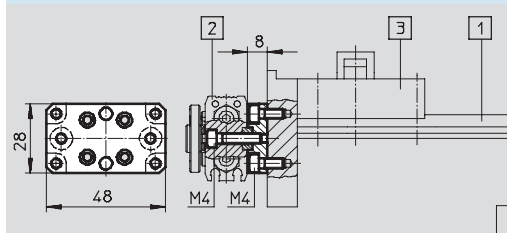





- 1 Handling module HSP
- 2 Semi-rotary drive DRQD
- 3 Adapter kit HAPG

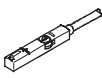

Handling modules HSP

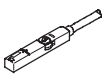
Accessories

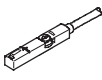
FESTO

| Ordering data – Proximity sensors for T-slot, magneto-resistive | | | | | | Technical data → Internet: smt | |
|---|--|---------------|-----------------------|------------------|----------|--------------------------------|--|
| | Type of mounting | Switch output | Electrical connection | Cable length [m] | Part No. | Type | |
| N/O contact | | | | | | | |
|  | Insertable in the slot from above, flush with cylinder profile | PNP | Cable, 3-wire | 2.5 | 543 867 | SMT-8M-PS-24V-K-2,5-OE | |
| | | | Plug M8x1, 3-pin | 0.3 | 543 866 | SMT-8M-PS-24V-K-0,3-M8D | |
| | | | Plug M12x1, 3-pin | 0.3 | 543 869 | SMT-8M-PS-24V-K-0,3-M12 | |
| | | NPN | Cable, 3-wire | 2.5 | 543 870 | SMT-8M-NS-24V-K-2,5-OE | |
| | | | Plug M8x1, 3-pin | 0.3 | 543 871 | SMT-8M-NS-24V-K-0,3-M8D | |
| | | | Plug M12x1, 3-pin | 0.3 | 543 872 | SMT-8M-NS-24V-K-0,3-M12 | |
|  | Insertable in the slot lengthwise, flush with the cylinder profile | PNP | Cable, 3-wire | 2.5 | 175 436 | SMT-8-PS-K-LED-24-B | |
| | | | Plug M8x1, 3-pin | 0.3 | 175 484 | SMT-8-PS-S-LED-24-B | |
| N/C contact | | | | | | | |
|  | Insertable in the slot from above, flush with cylinder profile | PNP | Cable, 3-wire | 7.5 | 543 873 | SMT-8M-PO-24V-K7,5-OE | |



| Ordering data – Proximity sensors for T-slot, magnetic reed | | | | | | Technical data → Internet: sme | | |
|---|--|---------------|-----------------------|------------------|----------|--------------------------------|------------------------|--|
| | Type of mounting | Switch output | Electrical connection | Cable length [m] | Part No. | Type | | |
| N/O contact | | | | | | | | |
|  | Insertable in the slot from above, flush with cylinder profile | Contacting | Cable, 3-wire | 2.5 | 543 862 | SME-8M-DS-24V-K-2,5-OE | | |
| | | | | 5.0 | 543 863 | SME-8M-DS-24V-K-5,0-OE | | |
| | | | Plug M8x1, 3-pin | Cable, 3-wire | 2.5 | 543 872 | SME-8M-ZS-24V-K-2,5-OE | |
| | | | | 0.3 | 543 861 | SME-8M-DS-24V-K-0,3-M8D | | |
|  | Insertable in the slot lengthwise, flush with the cylinder profile | Contacting | Cable, 3-wire | 2.5 | 150 855 | SME-8-K-LED-24 | | |
| | | | Plug M8x1, 3-pin | 0.3 | 150 857 | SME-8-S-LED-24 | | |
| N/C contact | | | | | | | | |
|  | Insertable in the slot lengthwise, flush with the cylinder profile | Contacting | Cable, 3-wire | 7.5 | 160 251 | SME-8-O-K-LED-24 | | |



| Ordering data – Connecting cables | | | | | Technical data → Internet: nebu | |
|---|-------------------------------|------------------------------|------------------|----------|---------------------------------|--|
| | Electrical connection, left | Electrical connection, right | Cable length [m] | Part No. | Type | |
|  | Straight socket, M8x1, 3-pin | Cable, open end, 3-wire | 2.5 | 541 333 | NEBU-M8G3-K-2.5-LE3 | |
| | | | 5 | 541 334 | NEBU-M8G3-K-5-LE3 | |
| | Straight socket, M12x1, 5-pin | Cable, open end, 3-wire | 2.5 | 541 363 | NEBU-M12G5-K-2.5-LE3 | |
| | | | 5 | 541 364 | NEBU-M12G5-K-5-LE3 | |
|  | Angled socket, M8x1, 3-pin | Cable, open end, 3-wire | 2.5 | 541 338 | NEBU-M8W3-K-2.5-LE3 | |
| | | | 5 | 541 341 | NEBU-M8W3-K-5-LE3 | |
| | Angled socket, M12x1, 5-pin | Cable, open end, 3-wire | 2.5 | 541 367 | NEBU-M12W5-K-2.5-LE3 | |
| | | | 5 | 541 370 | NEBU-M12W5-K-5-LE3 | |

Handling modules HSP

Accessories

FESTO

| Ordering data | | Technical data → Internet: abp, hmbn | |
|---|---|--------------------------------------|------------------|
| | Brief description | Part No. | Type |
| Slot cover for T-slot | | | |
|  | For protecting against ingress of dirt and securing proximity sensor cables. Scope of delivery: 2x 0.5 m | 151 680 | ABP-5-S |
| Slot nut for back plate | | | |
|  | Inserted from above | 189 654 | HMBN-5-M5 |

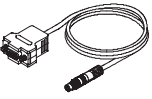
| Ordering data – Cables for HSP-AE | | | | |
|---|--|--------------|----------------|------------------------------|
| | Brief description | Cable length | Part No. | Type |
|  | Supply cable | 2.5 m | 537 931 | KPWR-MC-1-SUB-9HC-2,5 |
| | | 5 m | 537 932 | KPWR-MC-1-SUB-9HC-5 |
| | | 10 m | 537 933 | KPWR-MC-1-SUB-9HC-10 |
|  | Control cable for I/O connection to any PLC controller | 2.5 m | 537 923 | KES-MC-1-SUB-9-2,5 |
| | | 5 m | 537 924 | KES-MC-1-SUB-9-5 |
| | | 10 m | 537 925 | KES-MC-1-SUB-9-10 |
|  | Programming cable | 2.5 m | 537 926 | KDI-MC-M8-SUB-9-2,5 |

| Ordering data – Software for HSP-AE | | | |
|---|--|----------------|------------------------|
| | Brief description | Part No. | Type |
|  | The operator's package: – CD-ROM – With user's manual in the languages DE, EN, ES, FR, IT, SV – With configuration package FCT (Festo Configuration Tool) – Brief description The operator's package is included in the delivery. | 541 951 | P.BP-HSP_HSW-AE |

| Ordering data – Documentation for HSP-AE | | | | |
|---|--|----------|----------------|--------------------------|
| | Brief description | Language | Part No. | Type |
|  | Description User's manual in paper form is not included in the scope of delivery. | DE | 541 945 | P.BE-HSP-AE-IO-DE |
| | | EN | 541 946 | P.BE-HSP-AE-IO-EN |
| | | ES | 541 947 | P.BE-HSP-AE-IO-ES |
| | | FR | 541 948 | P.BE-HSP-AE-IO-FR |
| | | IT | 541 949 | P.BE-HSP-AE-IO-IT |
| | | SV | 541 950 | P.BE-HSP-AE-IO-SV |