

Three-point grippers HGD

FESTO



Three-point grippers HGD

Key features



At a glance

- Double-acting piston drive
- Self-centring
- Variable gripping action:
 - External/internal gripping
- Versatility thanks to externally adaptable gripper fingers
- Wide range of options for mounting on drive units
- Maximum precision
- High holding force
- Sensor technology:
 - Adaptable proximity sensors on the small grippers
 - Integral proximity sensors for medium and large grippers

-  - Note
 Sizing software
 Gripper selection
 → www.festo.com

Mounting options for external gripper fingers (customer-specific)

- 1 Three-point gripper
- 2 External gripper fingers
- 3 Mounting screws

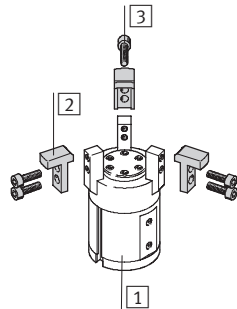

-  - Note
 Grippers should always be used with exhaust air flow control. They are not suitable for the following, or for similar applications:

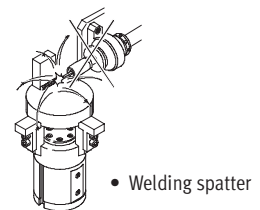
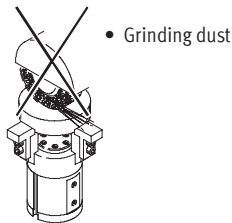
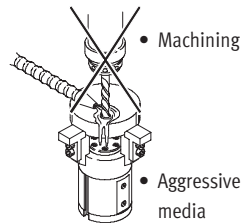

Three-point grippers HGD

Peripherals overview and type codes

Peripherals overview

HGD-16

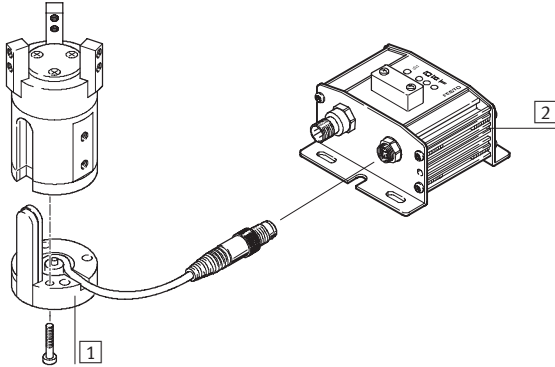

HGD-32/-50

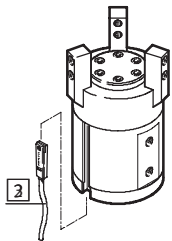

System product for handling and assembly technology

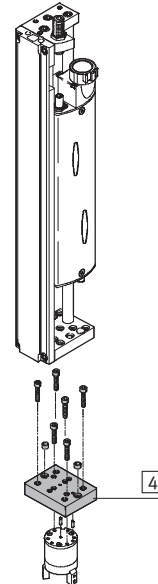

Accessories			
Type	Brief description	→ Page/Internet	
1	Position sensor SMH-S1 Adaptable and integratable sensor technology, for sensing the piston position	10	
2	Evaluation unit SMH-AE1 For position sensor SMH-S1	10	
3	Proximity sensor SME/SMT-8 For sensing the piston position	10	
4	- Drive/gripper connections	adapter kit	

Type codes

HGD	-	16	-	A
Type				
HGD	Three-point gripper			
Size				
Position sensing				
A	For proximity sensing			

Three-point grippers HGD

FESTO

Technical data

Function
Double-acting

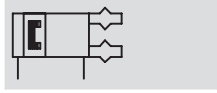

 www.festo.com

Wearing parts kits
→ 9



⌀ - Size
16 ... 50 mm

█ - Stroke
5 ... 12 mm

General technical data					
Size		16	32	50	
Design		Lever mechanism			
Mode of operation		Double-acting			
Gripper function		3-point			
Number of gripper jaws		3			
Max. applied load per external gripper finger ¹⁾	[N]	0.08	0.3	0.75	
Stroke	per gripper jaw	[mm]	2.5	3.9	6
	smallest gripping Ø ²⁾	[mm]	23	33.2	50
	largest gripping Ø ²⁾	[mm]	28	41	62
Pneumatic connection		M3	M5	G1/8	
Repetition accuracy ³⁾	[mm]	≤ 0.04			
Max. interchangeability	[mm]	0.2			
Max. operating frequency	[Hz]	4			
Position sensing		For proximity sensing			
Type of mounting		With female thread and locating hole			

- 1) Valid for unthrottled operation
- 2) Without external gripper fingers
- 3) Concentric to the central shaft

Operating and environmental conditions		
Min. operating pressure	[bar]	2
Max. operating pressure	[bar]	8
Operating medium		Filtered compressed air, lubricated or unlubricated
Ambient temperature	[°C]	+5 ... +60
Corrosion resistance class CRC ¹⁾		2

- 1) Corrosion resistance class 2 according to Festo standard 940 070
Components requiring moderate corrosion resistance. Externally visible parts with primarily decorative surface requirements which are in direct contact with a normal industrial environment or media such as coolants or lubricating agents

Weights [g]			
Size	16	32	50
HGD	110	300	985

Three-point grippers HGD

Technical data

Materials

Sectional view

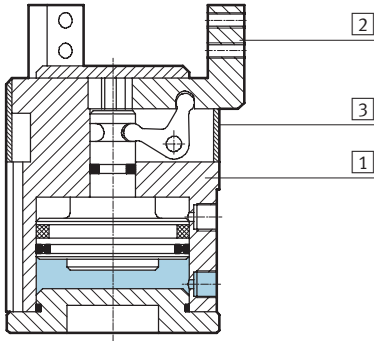

Three-point gripper		
1	Body	Nickel-plated aluminium
2	Gripper jaw	High-alloy steel, nickel plated
3	Cover cap	Polyacetate
-	Note on materials	Copper, PTFE and silicone-free Conforms to RoHS

Gripping force [N] at 6 bar

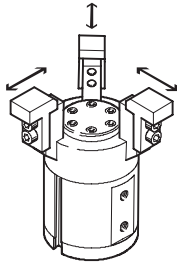

Size	16	32	50
Gripping force per gripper jaw			
Opening	40	137	323
Closing	30	120	293
Total gripping force			
Opening	120	410	970
Closing	90	360	880

Characteristic load values at the gripper jaws

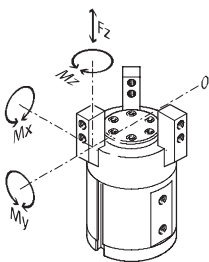

The indicated permissible forces and torques apply to a single gripper jaw. Static forces and torques relate to additional applied loads caused by

the workpiece or external gripper fingers, as well as forces which occur during handling. The zero co-ordinate

line (gripper jaws point of rotation) must be taken into consideration for the calculation of torques.

Size	16	32	50	
Max. permissible force F_z	[N]	34	90	173
Max. permissible torque M_x	[Nm]	0.5	1.6	4.7
Max. permissible torque M_y	[Nm]	0.8	2.8	8.1
Max. permissible torque M_z	[Nm]	0.5	1.9	5.3

Three-point grippers HGD

Technical data

Mass moment of inertia [$\text{kgm}^2 \times 10^{-4}$]

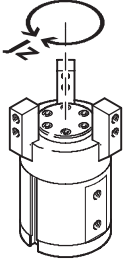

Mass moment of inertia [$\text{kgm}^2 \times 10^{-4}$] for three-point grippers in relation to the central axis, without external gripper fingers, without load.

Size	16	32	50
HGD	0.14	0.79	6.10

Opening and closing times [ms] at 6 bar

Without external gripper fingers

With external gripper fingers

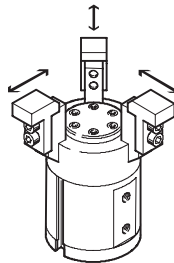
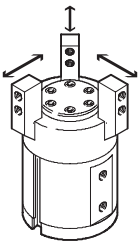

The indicated opening and closing times [ms] have been measured at room temperature and 6 bar operating pressure without external gripper fingers.

The grippers must be throttled for greater applied loads. Opening and closing times must then be adjusted accordingly.

Size		16	32	50
Without external gripper fingers				
HGD	Opening	5	10	10
	Closing	5	10	10
With external gripper fingers (as a function of applied load)				
HGD	0.08 N	5	–	–
	0.11 N	10	–	–
	0.15 N	20	–	–
	0.30 N	50	–	–
	0.50 N	–	100	–
	0.75 N	–	200	–
	1.00 N	–	300	100
	1.50 N	–	–	200
	2.00 N	–	–	300

Three-point grippers HGD

Technical data

Gripping force F per gripper as a function of operating pressure and the lever arm x

Gripping forces

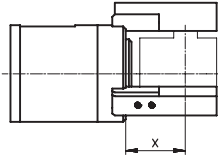

Gripping torques can be determined with the following diagrams for the various sizes in relation to operating

pressure and lever arm (distance from the zero co-ordinate line shown above

to the pressure point at which the external fingers grip the workpiece).

External gripping (closing)

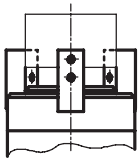

Internal gripping (opening)

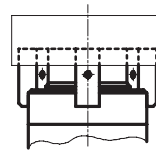

HGD-16-A

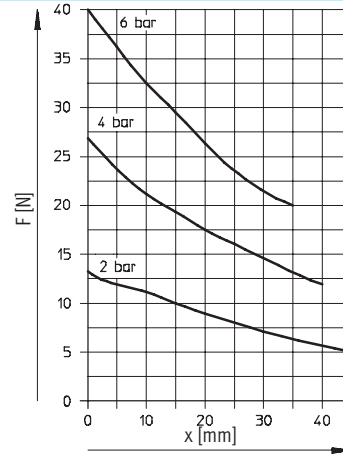
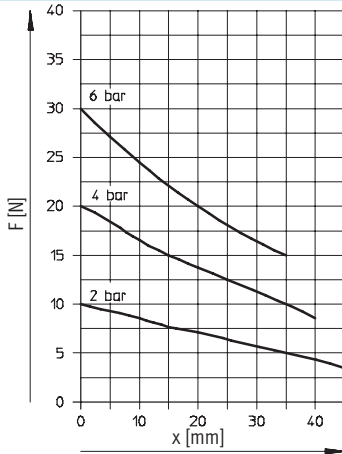

HGD-32-A

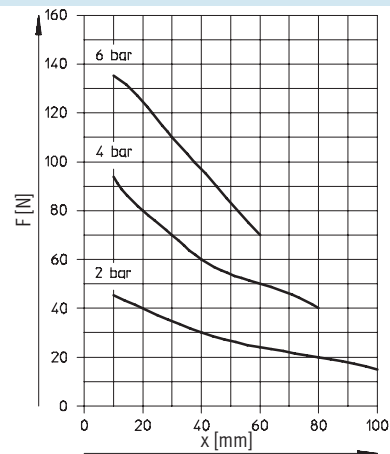
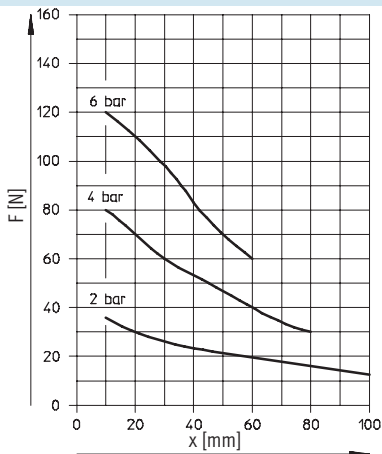

Three-point grippers HGD

Technical data

FESTO

Gripping force F per gripper as a function of operating pressure and the lever arm x

External gripping (closing)

Internal gripping (opening)

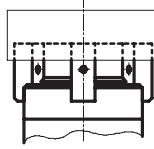
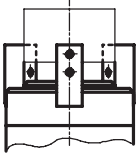

HGD-50-A

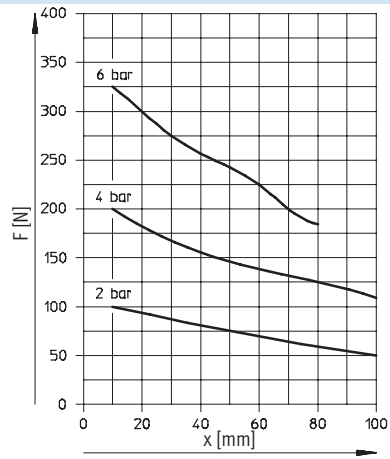
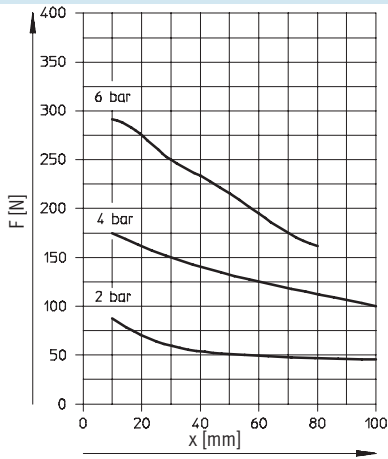

Three-point grippers HGD

Technical data

FESTO

Dimensions

Download CAD data → www.festo.com

Size 16

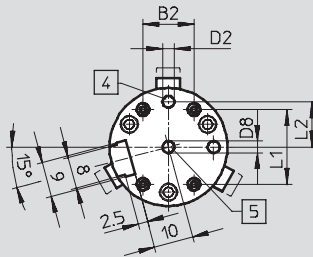

Size 32/50

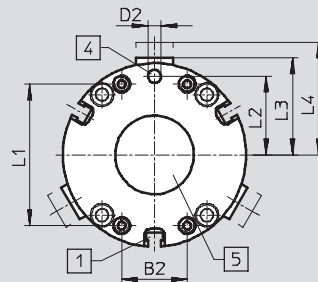

Size 16/32/50

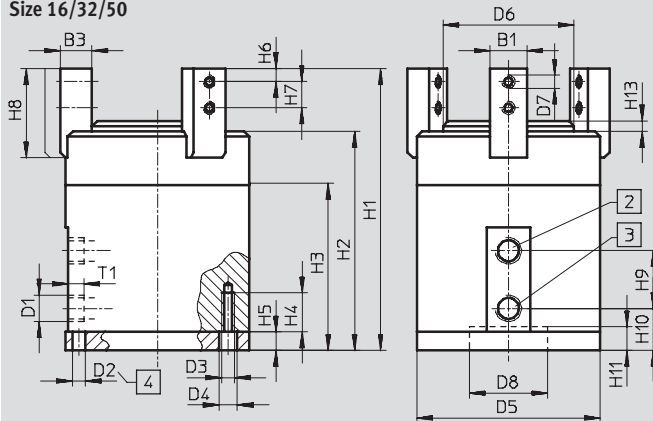

- 1 Sensor slot for proximity sensor SME/SMT-8 (not with HGD-16-A)
- 2 Compressed air connection, closing
- 3 Compressed air connection, opening
- 4 Drilled hole for locating pin (locating pins not included in scope of delivery)
- 5 Centring hole (user configured)

Size	B1	B2	B3	D1	D2	D3	D4	D5	D6	D7	D8	H1	H2
[mm]	-0.02		-0.02/-0.05		∅ H8		∅	∅	∅		∅		
16	6	13	7	M3	3	M3	3.2	30	21	M3	3 H7	60	46
32	10	13	8	M5	4	M3	3.7	45	32.4	M3	20+0.02/+0.05	78	62
50	14	25	12	G1/8	5	M5	6	70	49.4	M5	30+0.02/+0.05	107.5	83.5

Size	H3	H4	H5	H6	H7	H8	H9	H10	H11	H13	L1	L2	L3	L4	T1
[mm]		+1										±0.02			-0.5
16	32.6	8	4.5	3	6	21	12	11	4.5	2	19	11.5	17.5	20	4
32	44	10	6.5	3.5	6.5	22.5	16	11.8	8	3	36	19	24.6	28.5	4
50	56	16	7	5	10	34	22	16	9	4	54	30	37	43	6

Ordering data

Size	Double-acting	
[mm]	Part No.	Type
16	174 819	HGD-16-A
32	161 837	HGD-32-A
50	161 838	HGD-50-A



Ordering data – Wearing parts kits

Size	Wearing parts kits	
[mm]	Part No.	Type
16	378 535	HGD-16-A
32	125 694	HGD-32-A
50	125 695	HGD-50-A



Three-point grippers HGD

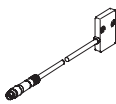

Accessories

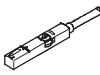

FESTO

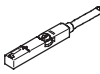
Ordering data						
Type	For size	Weight [g]	Part No.	Type	PU ¹⁾	
Position sensor SMH-S1			Technical data → Internet: smh-s1			
	16	30	175 713	SMH-S1-HGD16	1	
Evaluation unit SMH-AE1			Technical data → Internet: smh-ae			
	16	170	175 708	SMH-AE1-PS3-M12	1	
			175 709	SMH-AE1-NS3-M12		

1) Packaging unit quantity

Ordering data – Proximity sensors for T-slot, magneto-resistive							Technical data → Internet: sm	
	Type of mounting	Switch output	Electrical connection	Cable length [m]	Part No.	Type		
N/O contact								
	Insertable in the slot from above, flush with cylinder profile	PNP	Cable, 3-wire	2.5	543 867	SMT-8M-PS-24V-K-2,5-OE		
			Plug M8x1, 3-pin	0.3	543 866	SMT-8M-PS-24V-K-0,3-M8D		
		Plug M12x1, 3-pin	0.3	543 869	SMT-8M-PS-24V-K-0,3-M12			
		NPN	Cable, 3-wire	2.5	543 870	SMT-8M-NS-24V-K-2,5-OE		
	Plug M8x1, 3-pin		0.3	543 871	SMT-8M-NS-24V-K-0,3-M8D			
	Insertable in the slot lengthwise, flush with the cylinder profile	PNP	Cable, 3-wire	2.5	175 436	SMT-8-PS-K-LED-24-B		
			Plug M8x1, 3-pin	0.3	175 484	SMT-8-PS-S-LED-24-B		
N/C contact								
	Insertable in the slot from above, flush with cylinder profile	PNP	Cable, 3-wire	7.5	543 873	SMT-8M-PO-24V-K7,5-OE		

Ordering data – Proximity sensors for T-slot, magnetic reed							Technical data → Internet: sme	
	Type of mounting	Switch output	Electrical connection	Cable length [m]	Part No.	Type		
N/O contact								
	Insertable in the slot lengthwise, flush with the cylinder profile	Contacting	Cable, 3-wire	2.5	150 855	SME-8-K-LED-24		
			Plug M8x1, 3-pin	0.3	150 857	SME-8-S-LED-24		
N/C contact								
	Insertable in the slot lengthwise, flush with the cylinder profile	Contacting	Cable, 3-wire	7.5	160 251	SME-8-O-K-LED-24		

Ordering data – Connecting cables							Technical data → Internet: nebu	
	Electrical connection, left	Electrical connection, right	Cable length [m]	Part No.	Type			
	Straight socket, M8x1, 3-pin	Cable, open end, 3-wire	2.5	541 333	NEBU-M8G3-K-2.5-LE3			
			5	541 334	NEBU-M8G3-K-5-LE3			
	Straight socket, M12x1, 5-pin	Cable, open end, 3-wire	2.5	541 363	NEBU-M12G5-K-2.5-LE3			
			5	541 364	NEBU-M12G5-K-5-LE3			
	Angled socket, M8x1, 3-pin	Cable, open end, 3-wire	2.5	541 338	NEBU-M8W3-K-2.5-LE3			
			5	541 341	NEBU-M8W3-K-5-LE3			
	Angled socket, M12x1, 5-pin	Cable, open end, 3-wire	2.5	541 367	NEBU-M12W5-K-2.5-LE3			
			5	541 370	NEBU-M12W5-K-5-LE3			