

Passive guide axes FDG, without drive



Passive guide axes FDG, without drive

Key features

At a glance

- Driveless linear guide unit with guide and freely movable slide
- The passive guide axis/heavy-duty guide is designed to increase force and torque capacities in multi-axis applications
- Higher torsional resistance
- Reduced vibrations with dynamic loads
- Drive axis and passive guide axis/heavy-duty guide can be arranged adjacent to or above one another

System product for handling and assembly technology

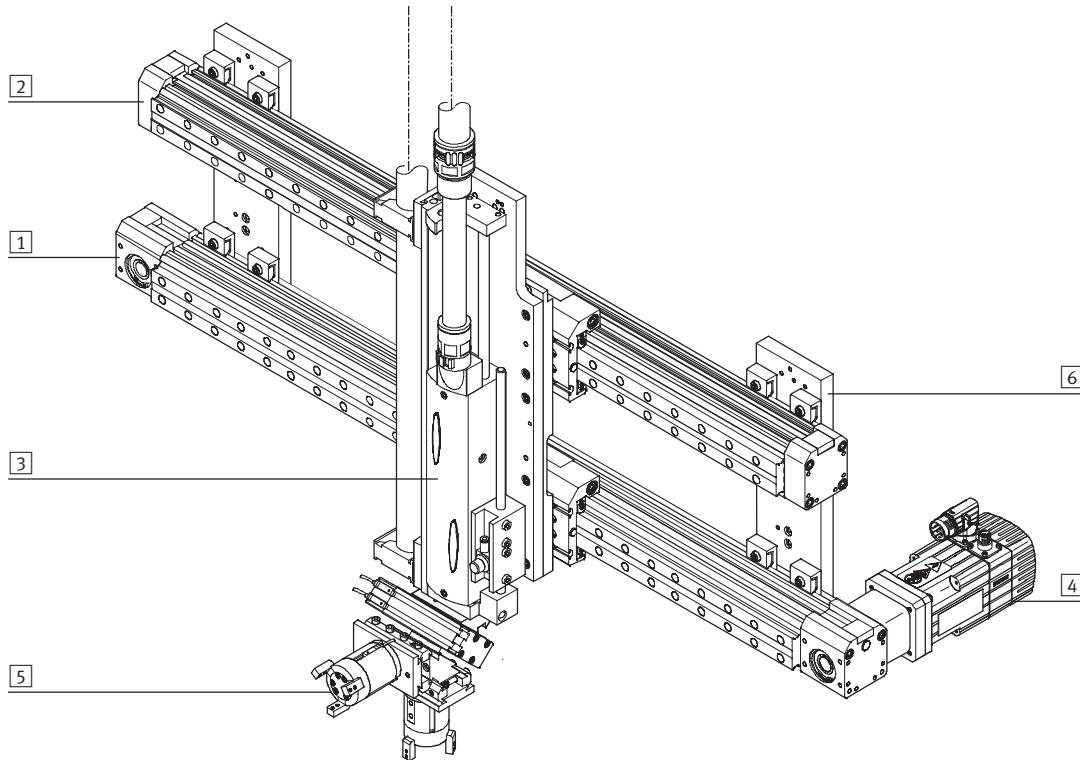

System components and accessories

	Brief description	→ Page/Internet
1	Axes	axis
2	Passive guide axes	guide axis
3	Drives	drive
4	Motors	motor
5	Grippers	gripper
6	Adapters	adapter kit

Passive guide axes FDG, without drive

Key features

FESTO

Guide axes and the corresponding drives

Passive guide axis DGC-FA



- Can be combined with:
 - Linear drive DGC-KF
- For size 8 ... 63
- Load capacity to max. 6,890 N or 380 Nm

Passive guide axis EGC-FA



- Can be combined with:
 - Toothed belt axis EGC-TB
 - Spindle axis EGC-BS
- For size 70 ... 185
- Load capacity to max. 15,200 N or 1,820 Nm

Passive guide axis FDG-ZR-RF



- Can be combined with:
 - Toothed belt axis DGE-ZR-RF
- For size 25 ... 63
- Load capacity to max. 1,500 N or 600 Nm

Passive guide axis FDG-P/-ZR/-SP



- Can be combined with:
 - Linear drive DGPL
 - Toothed belt axis DGE-ZR-KF
 - Spindle axis DGE-SP-KF
- For size 18 ... 63
- Load capacity to max. 14,050 N or 1,820 Nm

Heavy-duty guide HD

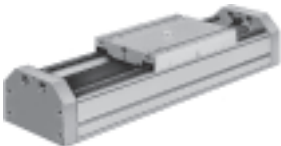

- Size HD8 ... HD40
- Stroke lengths of 10 ... 2,160 mm
- Load capacity to max. 5,600 N or 560 Nm

Passive guide axes FDG, without drive

Peripherals overview

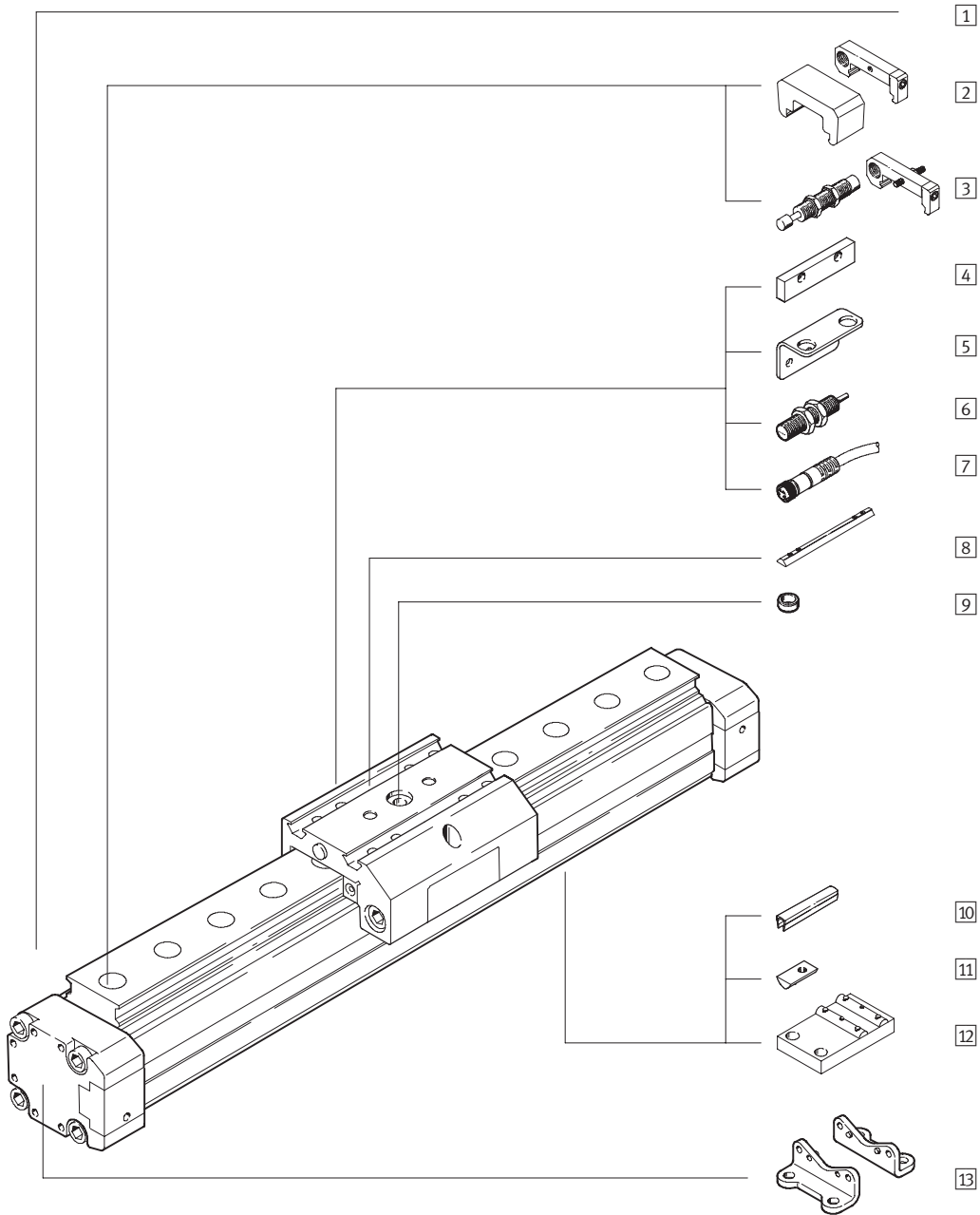
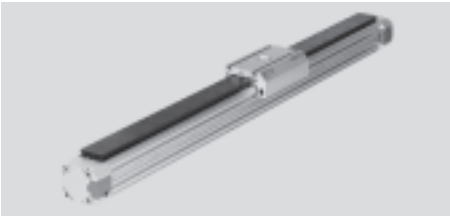

Passive guide axes FDG, without drive

Peripherals overview

Variants and accessories		
Type	Brief description	→ Page/Internet
1 Passive guide axis FDG	Guide without drive	6
2 Emergency buffer with retainer A	Absorbs the energy created by the movement of the slide when it reaches the end position	22
3 Shock absorber kits C/E	Absorbs the energy created by the movement of the slide when it reaches the end position	21
4 Switching lug L	For sensing the slide position	23
5 Sensor bracket T	Adapter for mounting the SIEN proximity sensor on the axis	23
6 Proximity sensors O/P/R/W	For providing a proximity signal or safety check	25
7 Cable with socket V	For proximity sensor	25
8 Slot nut for slide X	For mounting loads and attachments on the slide	24
9 Centring sleeve Z	For centring loads and attachments on the slide	24
10 Slot cover B/S	To protect against the ingress of dirt	24
11 Slot nut for mounting slot Y	For mounting attachments	24
12 Central support M	To mount the axis	20
13 Foot mounting F	To mount the axis	20

Passive guide axes FDG, without drive

Type codes

		FDG	-	25	-	500	-	ZR	-	KF	-	GK	-	
Type														
FDG	Guide unit without drive													
Size														
Stroke [mm]														
Passive guide axis														
ZR	For toothed belt axis DGE-ZR-KF													
SP	For spindle drive DGE-SP-KF													
P	For pneumatic linear drive DGPL													
Guide														
KF	Recirculating ball bearing guide													
Slide														
GK	Standard slide													
GV	Extended slide													
GA	Protected version													
Additional slide														
KL	Left													
KR	Right													

Passive guide axes FDG, without drive

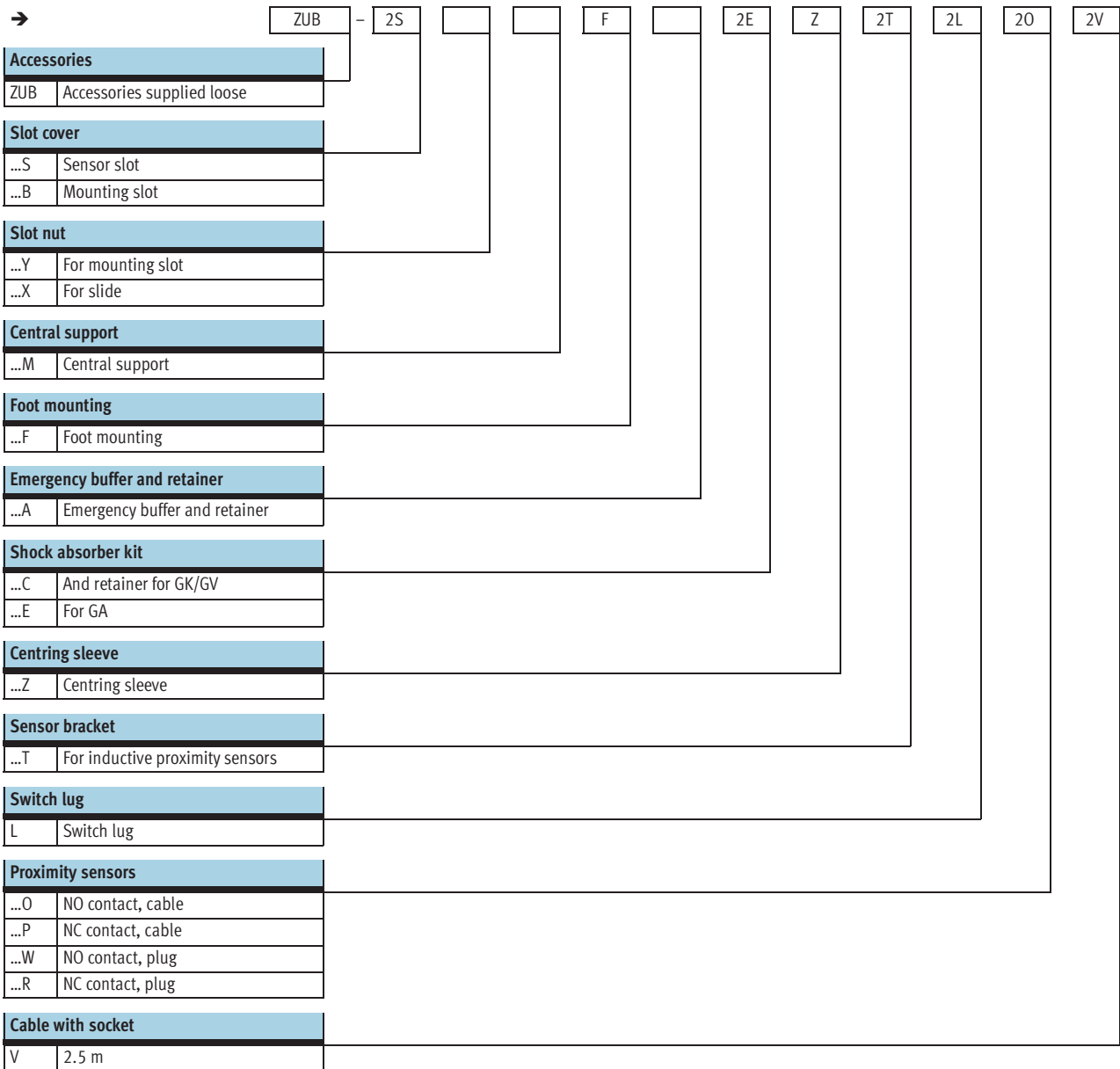

Type codes



Passive guide axes FDG, without drive

Technical data

FESTO

-  Size
18 ... 63
-  Stroke length
100 ... 5,100 mm

 www.festo.com

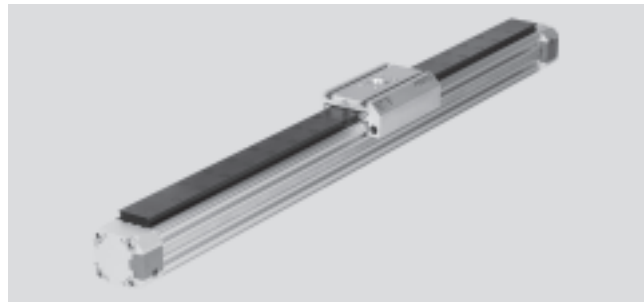

General technical data			18	25	32	40	50	63
Size			18	25	32	40	50	63
Max. stroke	FDG-ZR	[mm]	1 ... 1,000	1 ... 5,100	–	1 ... 4,900	–	1 ... 4,700
	FDG-SP	[mm]	1 ... 500	1 ... 1,000	–	1 ... 1,500	–	1 ... 2,000
	FDG-P	[mm]	10 ... 1,800	10 ... 3,000	10 ... 3,000	10 ... 3,000	10 ... 3,000	10 ... 3,000
Design	Driveless linear guide unit with slide							
Guide	External recirculating ball bearing guide							
Fitting position	Any							
Cushioning	Not adjustable at either end							
	Self-adjusting at both ends							
Type of mounting	Profile mounting							
	Foot mounting							
	Direct mounting							
Increase in no-load drive torque	for DGE-...-ZR by	[Nm]	0.005	0.02	–	0.03	–	0.085
	for DGE-SP by	[Nm]	0.04	0.1	–	0.15	–	0.45
Thrust ¹⁾		[N]	5	10	7	9	12	16
Ambient temperature		[°C]	–10 ... +60					

1) Measured at FDG-18 = 0.05 m/s; FDG-25... 63 = 0.2m/s

Weights [kg]			18	25	32	40	50	63
FDG-ZR								
Basic weight at 0 mm stroke	GK		0.879	2.022	–	6.055	–	21.493
	GV		1.341	2.927	–	7.939	–	31.464
	GA		–	2.931	–	8.128	–	–
Additional weight per 100 mm stroke	GK		0.274	0.479	–	0.968	–	2.423
	GV		0.274	0.479	–	0.968	–	2.423
	GA		–	0.570	–	1.092	–	–
FDG-SP								
Basic weight at 0 mm stroke	GK		0.743	1.482	–	4.296	–	13.454
	GV		1.232	2.530	–	7.678	–	25.847
	GA		–	2.459	–	6.798	–	–
Additional weight per 100 mm stroke	GK		0.274	0.479	–	0.968	–	2.423
	GV		0.274	0.479	–	0.968	–	2.423
	GA		–	0.570	–	1.092	–	–
FDG-P								
Basic weight at 0 mm stroke	GK		0.685	1.416	2.449	4.160	8.445	13.328
	GV		1.147	2.321	3.784	6.961	13.491	23.3
	GA		–	2.211	3.282	5.989	–	–
Additional weight per 100 mm stroke	GK		0.274	0.479	0.705	0.968	1.8	2.423
	GV		0.274	0.479	0.705	0.968	1.8	2.423
	GA		–	0.570	0.808	1.092	–	–

Passive guide axes FDG, without drive

Technical data

Materials

Sectional view

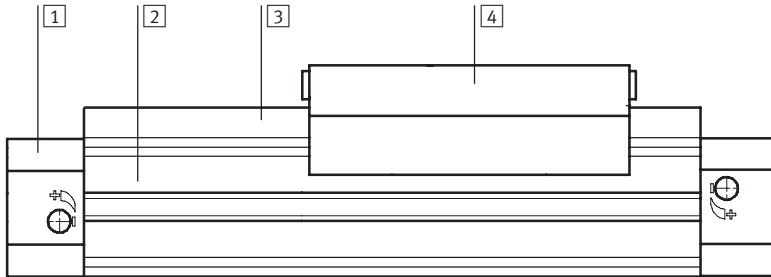

Axis		
1	End cap	Anodised aluminium
2	Profile	Anodised aluminium
3	Guide rail	∅ 18
		∅ 25 ... 63
		Hardened steel
		Hardened steel with corrosion resistant coating
4	Slide	Anodised aluminium
Note on material		Free of copper, PTFE and silicone

Characteristic load values

The forces and torques specified refer to the centre of the guide rails.

They must not be exceeded during dynamic operation. Special attention must be paid to the cushioning phase.

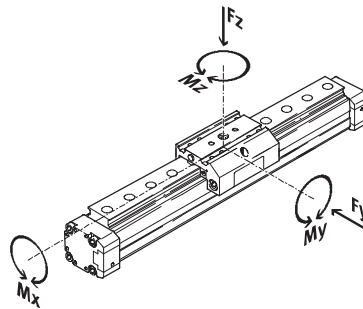

If the axis is simultaneously subjected to several of the forces and torques listed below, the following equations must be satisfied in addition to the indicated maximum loads.

$$\frac{F_y}{F_{y_{max}}} + \frac{F_z}{F_{z_{max}}} + \frac{M_x}{M_{x_{max}}} + \frac{M_y}{M_{y_{max}}} + \frac{M_z}{M_{z_{max}}} \leq 1$$

Permissible forces and torques							
Size		18	25	32	40	50	63
GK/GA – standard slide/protected slide							
F _y _{max.}	[N]	930	3,080	3,080	7,300	7,300	14,050
F _z _{max.}	[N]	930	3,080	3,080	7,300	7,300	14,050
M _x _{max.}	[Nm]	7	45	63	170	240	580
M _y _{max.}	[Nm]	23	85	127	330	460	910
M _z _{max.}	[Nm]	23	85	127	330	460	910
GV – extended slide							
F _y _{max.}	[N]	930	3,080	3,080	7,300	7,300	14,050
F _z _{max.}	[N]	930	3,080	3,080	7,300	7,300	14,050
M _x _{max.}	[Nm]	7	45	63	170	240	580
M _y _{max.}	[Nm]	45	170	250	660	920	1,820
M _z _{max.}	[Nm]	45	170	250	660	920	1,820

Passive guide axes FDG, without drive

Technical data

Maximum permissible support span l as a function of the force F

The axis may need to be supported with central supports MUP in order to limit deflection in the case of large strokes. The following diagrams serve to determine the maximum permissible support span l as a function of the force F .

Force on the surface of the slide

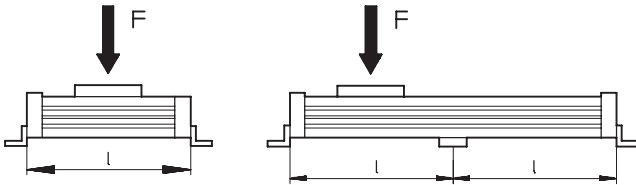

Maximum permissible support span l (without central support) as a function of the force F

Size 18...40

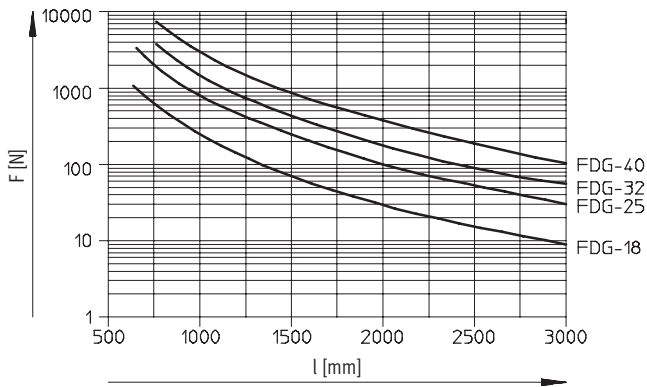

Size 50...63

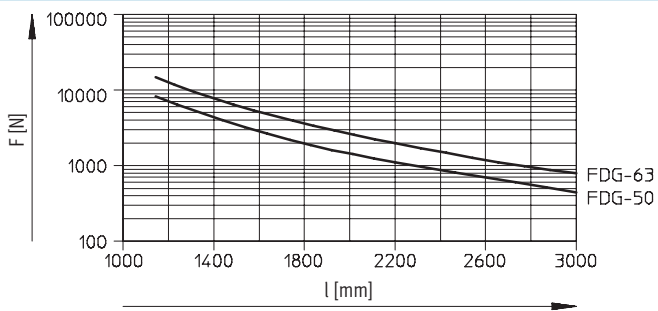

Passive guide axes FDG, without drive

Technical data

Dimensions Download CAD data → www.festo.com

Standard slide GK
Size 18-...

Technical drawing showing dimensions and callouts for the standard slide GK, size 18-... The drawing includes a front view with dimensions: 50.5, 32, 4.3, 57, 15°, 7, 24, 28, 34, 7, 24, 14, 17, 24, 11, 15.5, 3, 2, 5, 5, 7, M5, max. 10, 34, 34, 2, 3, 78+0.1, 20+0.1, 20+0.03, 10+0.1, 9, 85, L1+, L2. Callouts 2, 3, and 5 are present.

- 3 Mounting hole for foot mounting HP
- 5 Hole for centring ZBS-5
- + = plus stroke length

Extended slide GV
Size 18-P-GV

Technical drawing showing dimensions and callouts for the extended slide GV, size 18-P-GV. The drawing includes a side view with dimensions: 165, 40+0.03, 20+0.1, 40+0.03, 20+0.03, 10+0.1, L1+, L2. Callout 9 is present.

- + = plus stroke length

Extended slide GV
Size 18-ZR-/SP

Technical drawing showing dimensions and callouts for the extended slide GV with shock absorber and emergency buffer, size 18-ZR-/SP. The drawing includes a side view with dimensions: 15, 14, L1+, L2. Callouts 8 and 9 are present.

- 8 Shock absorber retainer KYP
- 9 Emergency buffer NPE
- + = plus stroke length

Size	L1		L2	
	GK	GV	GK	GV
FDG-18-...-P-...	150	230	75	115
FDG-18-...-ZR-...	221	301	110.5	150.5
FDG-18-...-SP-...	171	261	92	132

Passive guide axes FDG, without drive

Technical data

FESTO

Dimensions

Download CAD data → www.festo.com

Standard slide GK

Size 25-...

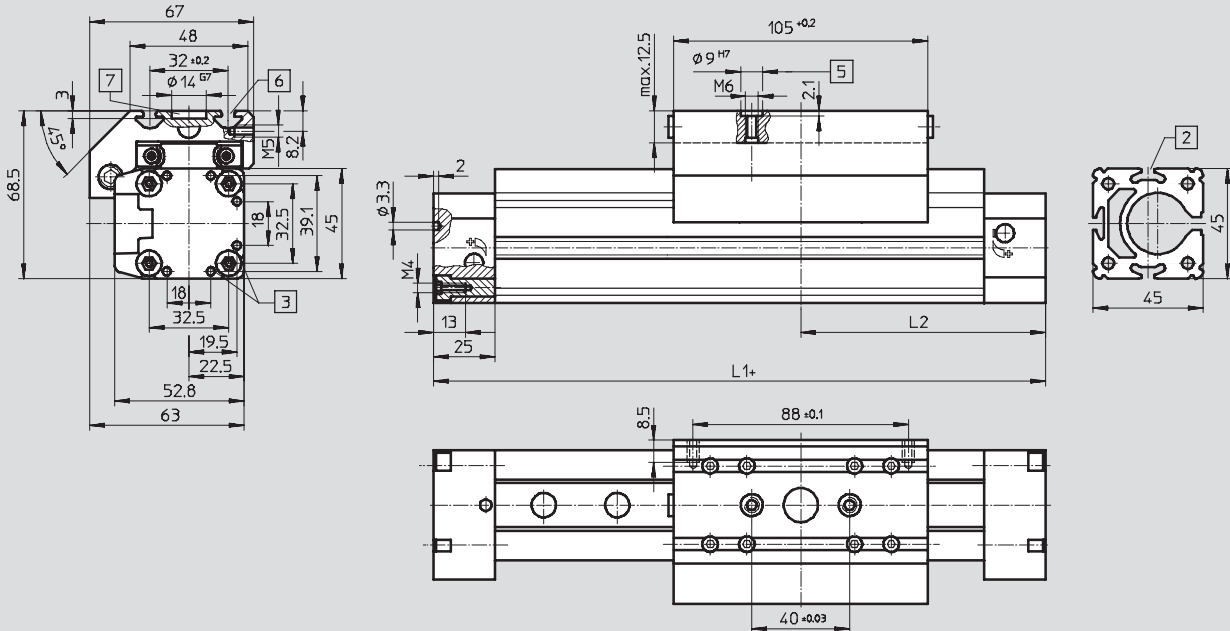

- 3 Mounting hole for foot mounting HP
- 5 Hole for centring sleeve ZBH-9
- 6 Mounting slot for slot nut NSTL + = plus stroke length
- 7 Drilled hole for central mounting SLZZ

Extended slide GV

Size 25-P

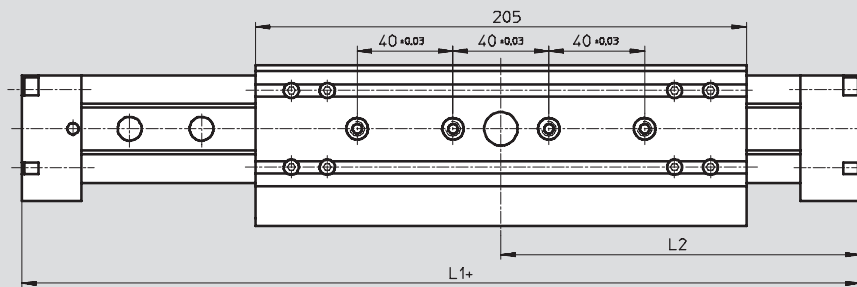

Extended slide GV

Size 25-ZR/-SP

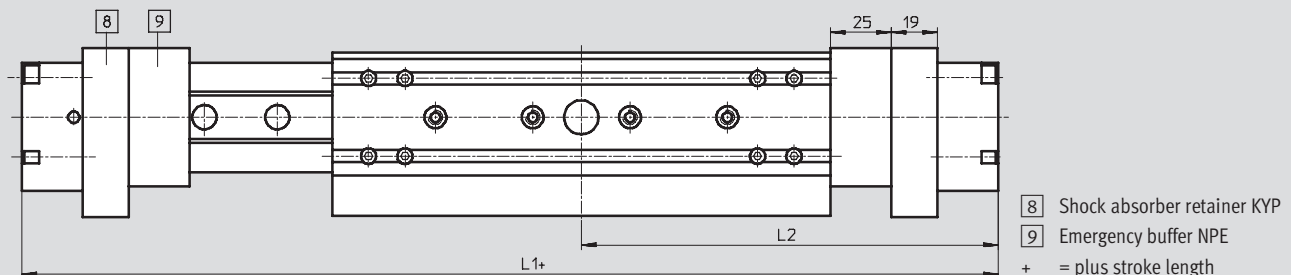

- 8 Shock absorber retainer KYP
- 9 Emergency buffer NPE
- + = plus stroke length

Passive guide axes FDG, without drive

Technical data

Dimensions

Download CAD data → www.festo.com

Protected version GA

Size 25-...GA

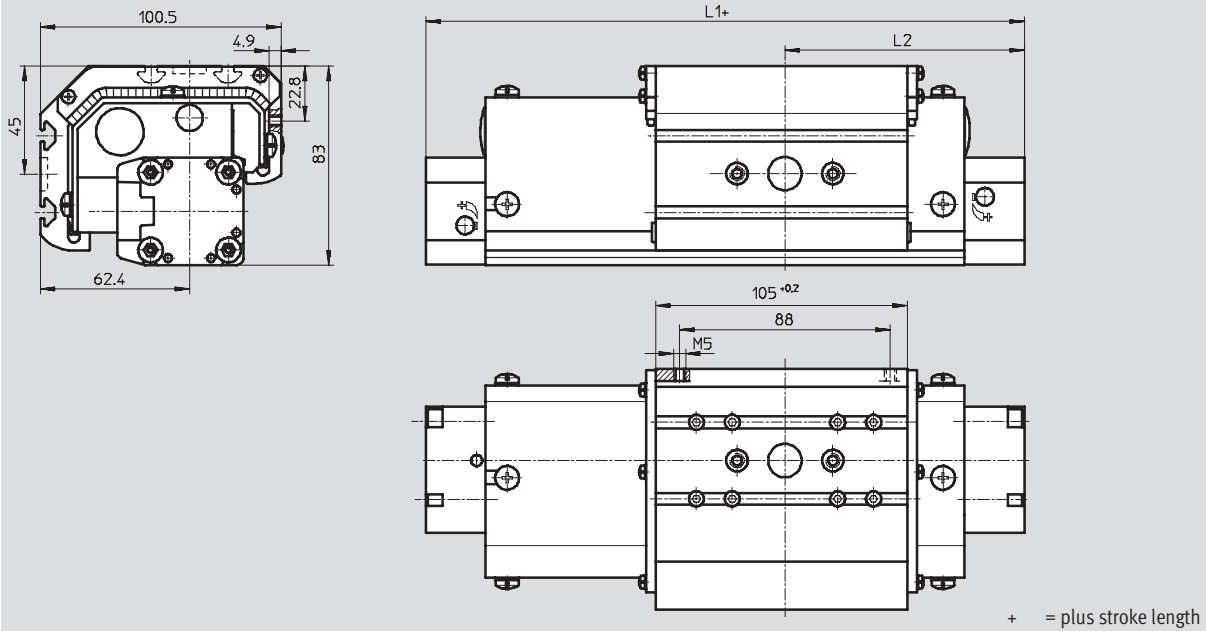

Size	L1			L2		
	GK	GV	GA	GK	GV	GA
FDG-25-...-P-...	200	300	200	100	150	100
FDG-25-...-ZR-...	326	426	326	163	213	163
FDG-25-...-SP-...	213	343	243	101.5	171.5	121.5

Passive guide axes FDG, without drive

Technical data

FESTO

Dimensions

Download CAD data → www.festo.com

Standard slide GK

Size 32...63-...

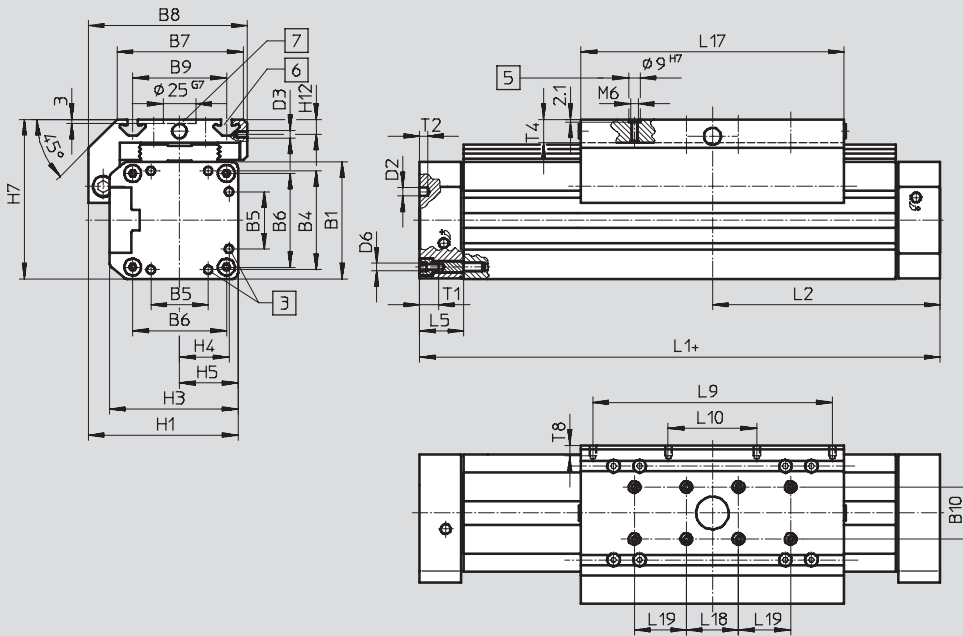

- 3 Mounting hole for foot mounting HP
- 5 Hole for centring sleeve ZBH-9
- 6 Mounting slot for slot nut NSTL
- 7 Drilled hole for central mounting SLZZ
- + = plus stroke length

Extended slide GV

Size 32...63-P

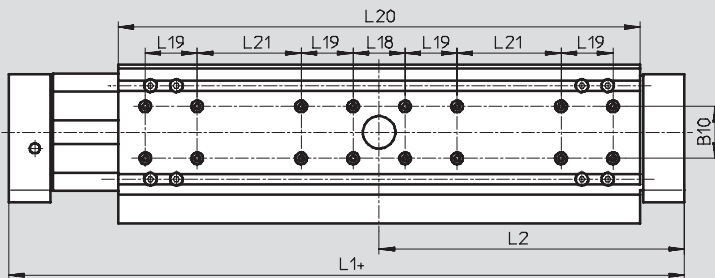

+ = plus stroke length

Extended slide GV

Size 40/63-ZR/-SP

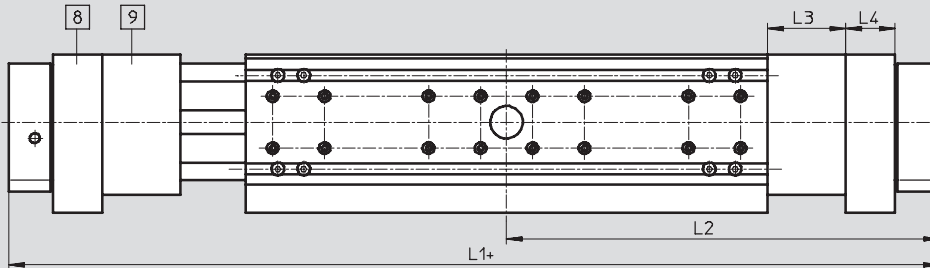

- 8 Shock absorber retainer KYP
- 9 Emergency buffer NPE
- + = plus stroke length

Profile barrel

Size 32

Size 40

Size 50

Size 63

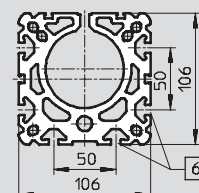
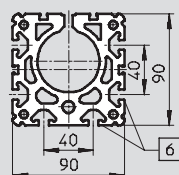
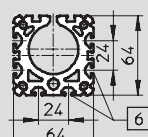
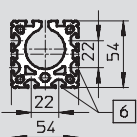

- 6 Mounting slot for slot nut NST

Passive guide axes FDG, without drive

Technical data

FESTO

Dimensions Download CAD data → www.festo.com

Dust-proof version
Size 32/40-...GA

+ = plus stroke length

Size	L1			L2		
	GK	GV	GA	GK	GV	GA
FDG-32-...-P-...-	250	380	250	125	190	125
FDG-40-...-P-...-	300	470	300	150	235	150
FDG-50-...-P-...-	350	550	-	175	275	-
FDG-63-...-P-...-	400	650	-	200	325	-
FDG-40-...-ZR-...-	497	667	497	248.5	333.5	248.5
FDG-63-...-ZR-...-	738	988	-	369	494	-
FDG-40-...-SP-...-	315	545	375	153	271.5	186.5
FDG-63-...-SP-...-	406	756	-	198	378	-

Size	B1	B2	B3	B4	B5	B6	B7	B8	B9	B10	D2 ∅	D3
									±0.2			
32	54	112.1	-	46	21	40	63	79	47	20	4.3	M5
40	64	137.6	7	53	28	49	78.5	96.5	55	20	4.3	M5
50	90	-	-	76	44	72	97	122	72	40	6.3	M6
63	106	-	-	89	44	83	121	142	90	40	6.3	M8

Size	D6	H1	H2	H3	H4	H5	H7	H8	H9	H10	H11	H12	L3
32	M5	72	66	62	23	27	77.5	93.1	49.5	64.5	-	8.3	-
40	M5	86	78	71.8	26.5	32	90.5	106.6	54	79.6	23.1	7	40
50	M6	115	106	99	36	45	122.5	-	-	-	-	11.5	-
63	M8	131	122	115	44.5	53	144.5	-	-	-	39.5	12.5	63

Size	L4	L5	L9	L10	L17	L18	L19	L20	L21	T1	T2	T4	T8
			±0.1	±0.1	±0.2	±0.03	±0.03		±0.1				
32	-	31	112	-	131	40	-	261	40	13.2	3	12.5	8.5
40	32	31	150	58	167	40	40	337	40	13.2	4	12.5	8.5
50	-	34	184	68	202	40	40	402	80	15.2	6	18.5	8
63	44	34	200	72	230	40	40	480	120	21.2	6	20.5	10.5

Passive guide axes FDG, without drive

Ordering data – Modular product system



Order code

Mandatory data/Options

Standard slide GK

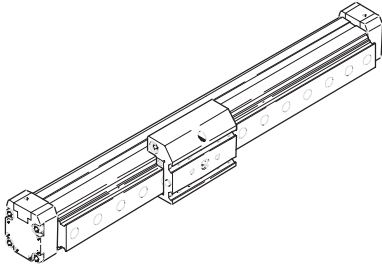

Standard slide plus additional slide GK-KL/-KR

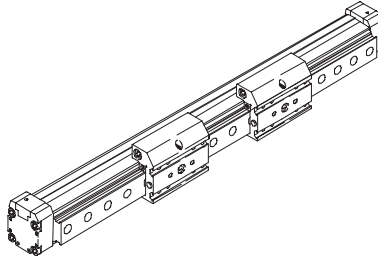

Extended slide GV

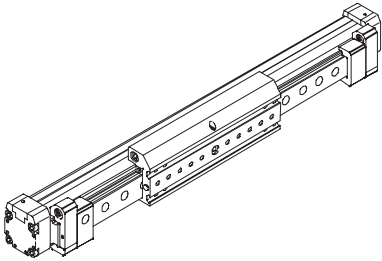

Extended slide plus additional slide GK-KL/-KR

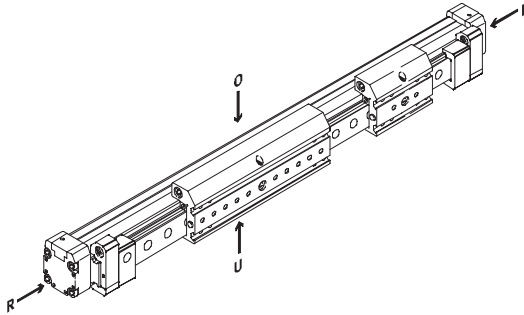

Dust-proof version GA

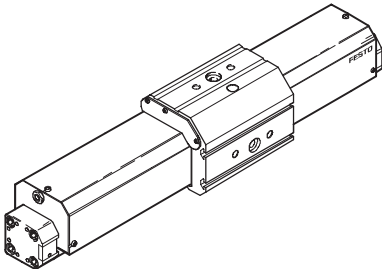

-  - Note

O = top

R = right

U = underneath

L = left

Passive guide axes FDG, without drive

Ordering data – Modular product system

Order code

Options

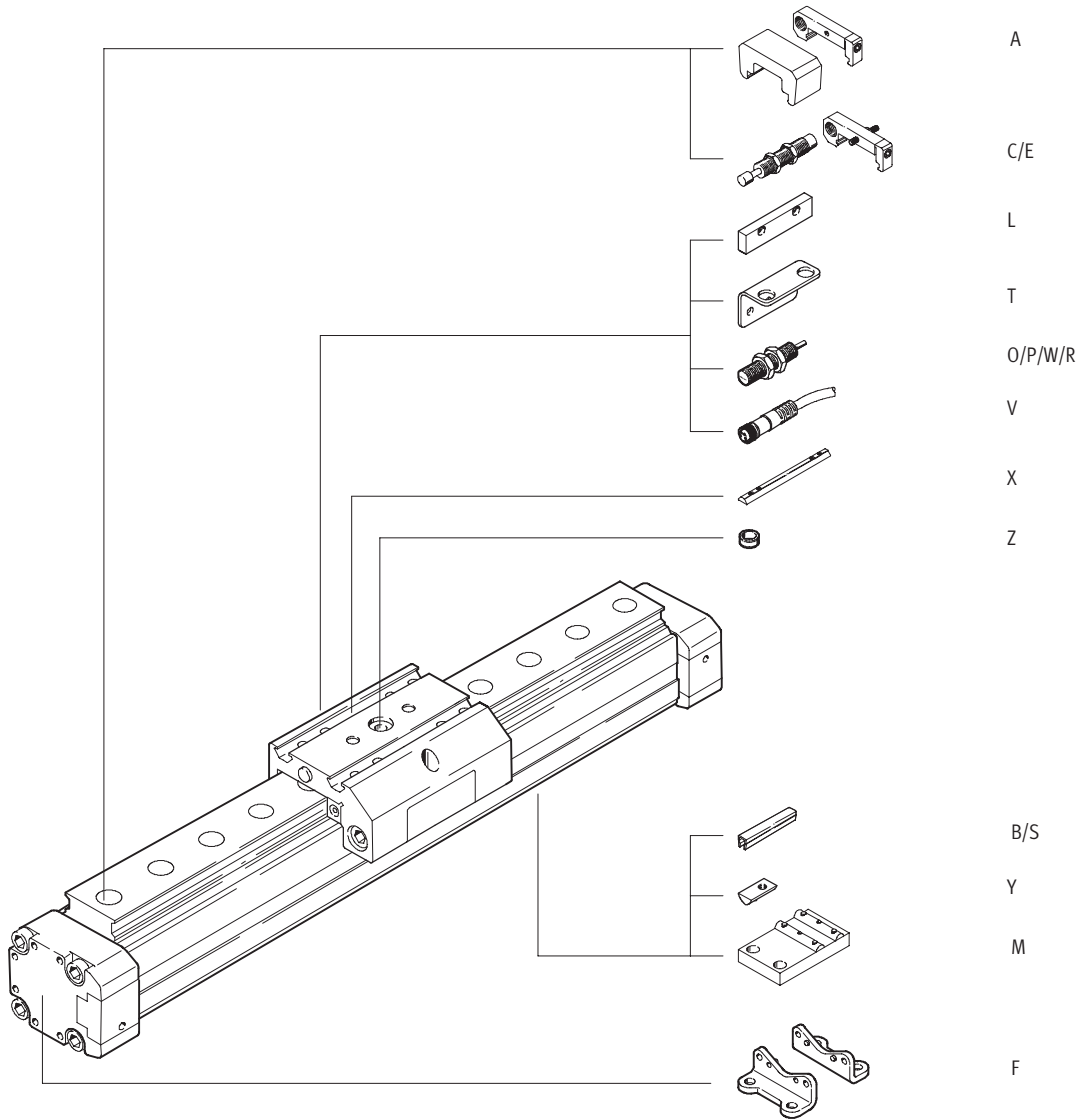

Passive guide axes FDG, without drive

Ordering data – Modular product system



M Mandatory data							O Options →
Module No.	Drive function	Size	Stroke	Passive guide axis	Guide	Slide	Additional slide
192 850	FDG	18	1 ... 5 100	ZR SP P	KF	GK GV GA	KL KR
192 851		25					
192 852		32					
192 853		40					
192 854		50					
192 855		63					
Ordering example							
192 853	FDG	- 40	- 500	- ZR	- KF	- GK	-

Ordering table										
Size	18	25	32	40	50	63	Condi- tions	Code	Enter code	
M Module No.	192 850	192 851	192 852	192 853	192 854	192 855				
Drive function	Guide unit without drive								FDG	FDG
Size	18	25	32	40	50	63		-...		
Stroke [mm] with ZR (as for corresponding drive axis)	with ZR	1 ... 1 000	1 ... 5 100	-	1 ... 4 900	-	1 ... 4 700	-...		
	with SP	1 ... 500	1 ... 1 000	-	1 ... 1 500	-	1 ... 2 000			
	with P	10 ... 1 800	10 ... 3 000	10 ... 3 000	10 ... 3 000	10 ... 3 000	10 ... 3 000			
Passive guide axis	for	DGE-ZR	DGE-ZR	-	DGE-ZR	-	DGE-ZR	-ZR		
	for	DGE-SP	DGE-SP	-	DGE-SP	-	DGE-SP	-SP		
	for	DGP	DGP	DGP	DGP	DGP	DGP	-P		
Guide	Recirculating ball bearing guide								-KF	-KF
Slide	Standard								-GK	
	Extended								-GV	
	Maximum stroke [mm]									
	with ZR	(920)	(5 000)	-	(4 730)	-	(4 450)			
	with SP	(410)	(870)	-	(1 270)	-	(1 650)			
	Protected version							[1]	-GA	
	Maximum stroke [mm]									
	with ZR	-	(1 800)	-	(1 800)	-	-			
with SP	-	(970)	-	(1 440)	-	-				
with P	-	(2 000)	(2 000)	(2 000)	-	-				
O Additional slide	Standard slide left							[2]	-KL	
	Standard slide right							[2]	-KR	

[1] GA Not with accessories T, L, O, P, W, R.

[2] KL, KR Only with slide GK or GV.

Transfer order code

Passive guide axes FDG, without drive

Ordering data – Modular product system

Options											
Accessories	Slot cover	Slot nut	Central support	Foot mounting	Emergency buffer and retainer	Shock absorber	Centring sleeve	Sensor bracket	Switching lug	Proximity sensors	Plug socket
ZUB	...S ...B	...Y ...X	...M	...F	...A	...C ...E	...Z	...T	L	...O ...P ...W ...R	...V
ZUB	SB	4Y2X		F		2C	10Z			20	

Ordering table										
Size	18	25	32	40	50	63	Conditions	Code	Enter code	
Accessories	Supplied separately								ZUB-	ZUB-
Slot cover	Sensor slot	1 ... 10							...S	
	Mounting slot	–	–	1 ... 10				...B		
Slot nut	for mounting slot	1 ... 10							...Y	
	for slide	–	1 ... 10					...X		
Central support	1 ... 10							...M		
Foot mounting (kit)	1 ... 10							...F		
Emergency buffer and retainer	1 ... 2	1 ... 2	–	1 ... 2	–	1 ... 2	[3]	...A		
	Effective stroke reduction [mm] with emergency buffer at both ends									
	(10)	(30)	–	(60)	–	(100)				
Shock absorber and retainer	1 ... 2						[4]	...C		
	for dust-proof version	–	1 ... 2		–	–	[5]	...E		
Centring sleeve (pack of 10)	10, 20, 30, 40, 50, 60, 70, 80, 90							...Z		
Sensor bracket	1 ... 5		–	1 ... 5		–	1 ... 5	...T		
Switching lug	1							L		
Inductive proximity sensor	NO contact, cable	1 ... 5		–	1 ... 5		–	1 ... 5	...O	
	NC contact, cable	1 ... 5		–	1 ... 5		–	1 ... 5	...P	
	NO contact, plug	1 ... 5		–	1 ... 5		–	1 ... 5	...W	
	NC contact, plug	1 ... 5		–	1 ... 5		–	1 ... 5	...R	
Cable with socket, 2.5 m	1 ... 5		–	1 ... 5		–	1 ... 5	...V		

- [3] A Not with passive guide axis P.
Mounted as standard for slides GV, GA.
- [4] C Only with slides GK and GV.

- [5] E Only with slide GA

Transfer order code

ZUB –

Passive guide axes FDG, without drive

Accessories



Foot mounting HP (Order code: F)

Material:
Galvanised steel

Free of copper, PTFE and silicone



HP-25

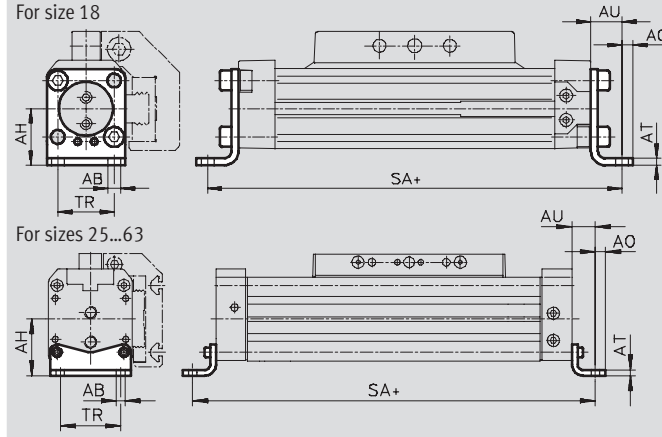

+ = plus stroke length

Dimensions and ordering data

For size	AB ∅	AH	AO	AT	AU	SA	TR	Weight [g]	Part No.	Type
18	5.5	24	4.8	3	13.2	176	24	70	158 472	HP-18
25	5.5	29.5	6	3	13	226	32.5	61	150 731	HP-25
32	6.6	37	7	4	17	284	38	117	150 732	HP-32
40	6.6	46	8.5	5	17.5	335	45	188	150 733	HP-40
50	9	61	11	6	25	400	65	243	150 734	HP-50
63	11	69	13.5	6	28	456	75	305	150 735	HP-63

Central support MUP (Order code: M)

Material:
Galvanised steel

Free of copper, PTFE and silicone



MUP-40

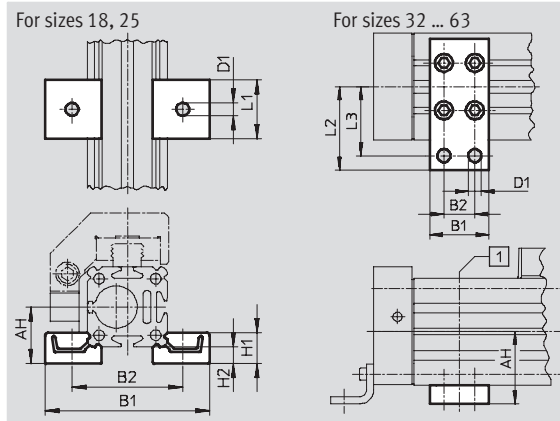

1 Position of the central support along the profile barrel is freely selectable

Dimensions and ordering data

For size	AH	B1	B2	D1 ∅	H1	H2	L1	L2	L3	Weight [g]	Part No.	Type
18	24	70.5	47	5.5	13	7	25	-	-	33	150 736	MUP-18/25
25	29.5	81	58	5.5	13	7	25	-	-	33	150 736	MUP-18/25
32	37	35	22	6.6	-	-	-	41.5	35	89	150 737	MUP-32
40	46	35	22	6.6	-	-	-	47	40	126	150 738	MUP-40
50	61	50	26	11	-	-	-	70	58	241	150 739	MUP-50
63	69	50	26	11	-	-	-	77	65	340	150 800	MUP-63

Passive guide axes FDG, without drive

Accessories

Shock absorber YSR-...-C

(Order code: C)

Material:

Housing: Galvanised steel; piston rod: high-alloy steel,
Seals: Perbunan, polyurethane
Free of copper, PTFE and silicone



 Note
Shock absorber YSRW with progressive characteristic
→ Internet: ysrw

Ordering data		Part No.	Type
For size	Weight [g]		
18	30	34 571	YSR-8-8-C
25	70	34 572	YSR-12-12-C
32	70	34 572	YSR-12-12-C
40	140	34 573	YSR-16-20-C
50	140	34 573	YSR-16-20-C
63	240	34 574	YSR-20-25-C

Shock absorber retainer KYP

(Order code: C)

Material:

Retainer: Aluminium
Sleeve: Steel, corrosion resistant

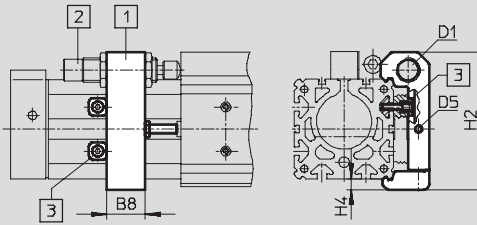
1 Shock absorber retainer KYP
(if the retainer is in contact with the front cap, i.e. cap serves to secure the position, the entire stroke length can be utilised)

2 Shock absorber YSR-...-C

3 Position retainer
(included in scope of delivery) either behind or underneath the shock absorber retainer KYP

Dimensions and ordering data							
For size	B8	D1	D5	H2	H4	Weight [g]	Part No. Type
18	14	M12x1	M4	50.5	4.5	66	158 907 KYP-18
25	19	M16x1	M5	69.5	6	95	158 908 KYP-25
32	25	M16x1	M5	80	8	130	158 909 KYP-32
40	32	M22x1.5	M5	102	8	209	158 910 KYP-40
50	35	M22x1.5	M8	124	10	415	158 911 KYP-50
63	44	M26x1.5	M10	152.5	11.5	609	158 912 KYP-63

Passive guide axes FDG, without drive

Accessories

FESTO

Emergency buffer NPE

(Order code: A)

Material:
Polyurethane

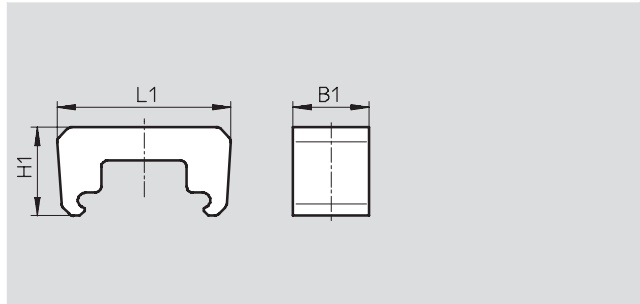
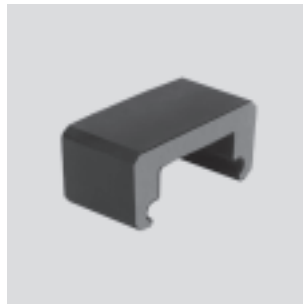

Dimensions and ordering data						
For size	B1	L1	H1	Weight [g]	Part No.	Type
18	15	43.1	28.5	6	193 901	NPE-18
25	25	57	29	12	193 902	NPE-25
40	40	80.5	36	41	193 904	NPE-40
63	60	128.6	55	152	193 906	NPE-63

 Note
The emergency buffer can only be used in conjunction with shock absorber retainer KYP. → 21
(A threaded pin and nut are not required.)

Shock absorber DG-GA

for protected version GA

(Order code: E)

Material:
Housing: Galvanised steel; piston rod: high-alloy steel
Seals: Perbunan, polyurethane
Free of copper, PTFE and silicone



Ordering data			
For size	Weight [g]	Part No.	Type
25	70	192 875	DG-GA-25-YSR
40	140	192 877	DG-GA-40-YSR

Passive guide axes FDG, without drive

Accessories

Sensor bracket HWS

For inductive proximity sensors

(Order code: T)

Material:

Galvanised steel



Switching lug SF

(Order code: L)

Material:

Galvanised steel

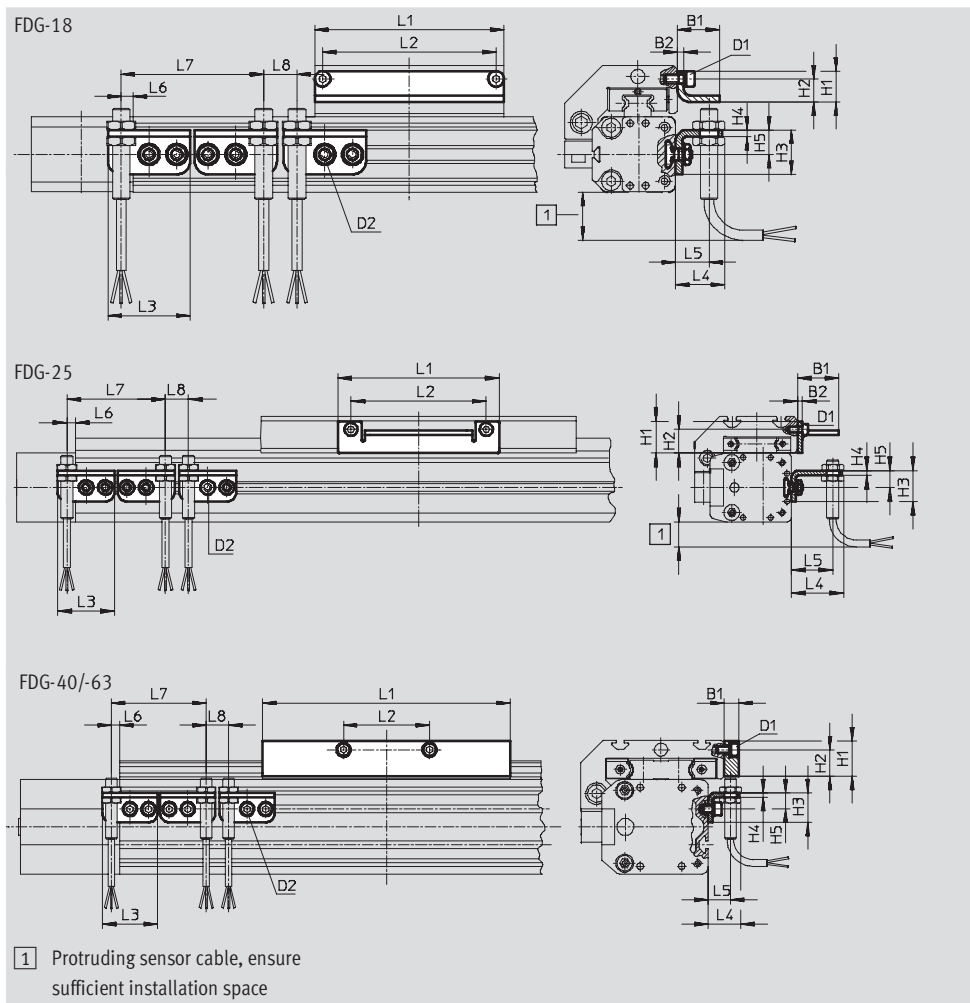



Dimensions and ordering data											
For size	D1	D2	B1	B2	H1	H2	H3	H4	H5	L1	L2
18	M4	M5	19	3	14	10.5	20	3	11	85	78
25	M5	M5	27	3	20.5	15.3	20	3	11	105	88
40	M5	M5	10	-	24	18	20	3	11	167	58
63	M8	M5	10	-	35	25	20	3	11	230	72

For size	L3	L4	L5	L6 max.	L7 min.	L8 min.	Weight [g]	Part No.	Type
18	37	22.5	15	5.5	64	15	30	188 968	HWS-18/25-M8
							60	188 964	SF-18
25	37	34.5	27	5.5	64	15	30	540 780	HWS-25-MAB-M8
							80	540 430	SF-25-MAB
40	37	22.5	15	5.5	64	15	40	188 969	HWS-40-M8
							310	188 966	SF-40
63	37	22.5	15	5.5	64	15	40	188 970	HWS-63-M8
							630	188 967	SF-63

Passive guide axes FDG, without drive

Accessories

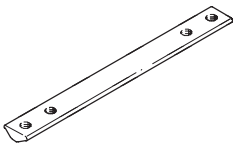
FESTO

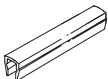
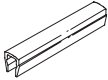



Ordering data						
	For size	Remarks	Order code	Part No.	Type	PU ¹⁾
Slot nut NST Technical data → Internet: nst						
	18, 25	For mounting slot	Y	526 091	NST-HMV-M4	1
	32, 40			150 914	NST-5-M5	1
	50, 63			150 915	NST-8-M6	1
Slot nut NSTL Technical data → Internet: nstl						
	25	For slide	X	158 410	NSTL-25	1
	32			158 411	NSTL-32	1
	40			158 412	NSTL-40	1
	50			158 413	NSTL-50	1
	63			158 414	NSTL-63	1
Centring pin/sleeve ZBS/ZBH Technical data → Internet: zbs, zbh						
	18	For slide	Z	150 928	ZBS-5	10
	25 ... 63			150 927	ZBH-9	10
Slot cover ABP Technical data → Internet: abp						
	32, 40	For mounting slot 0.5 m each	B	151 681	ABP-5	2
	50, 63			151 682	ABP-8	
Slot cover ABP-S Technical data → Internet: abp						
	18 ... 63	For sensor slot 0.5 m each	S	151 680	ABP-5-S	2



1) Packaging unit quantity

Passive guide axes FDG, without drive

Accessories

FESTO

Ordering data – Inductive proximity sensors M8						Technical data → Internet: sien	
	Electrical connection		Switch output	LED	Cable length [m]	Part No.	Type
	Cables	M8 plug					
NO contact							
	3-wire	–	PNP	■	2.5	150 386	SIEN-M8B-PS-K-L
	–	3-pin	PNP	■		150 387	SIEN-M8B-PS-S-L
NC contact							
	3-wire	–	PNP	■	2.5	150 390	SIEN-M8B-PO-K-L
	–	3-pin	PNP	■		150 391	SIEN-M8B-PO-S-L

Ordering data – Connecting cables					Technical data → Internet: nebu		
	Electrical connection, left		Electrical connection, right		Cable length [m]	Part No.	Type
		Straight socket, M8x1, 3-pin		Cable, open end, 3-wire			
					5	541 334	NEBU-M8G3-K-5-LE3
	Angled socket, M8x1, 3-pin		Cable, open end, 3-wire		2.5	541 338	NEBU-M8W3-K-2.5-LE3
					5	541 341	NEBU-M8W3-K-5-LE3