

Stepper motors EMMS-ST



# Stepper motors EMMS-ST

Key features

## Everything from a single source

Stepper motors EMMS-ST

→ 4



- 2-phase hybrid technology
- Optionally integrated encoder for “Servo Lite operation” (closed loop)
- Sinusoidal current impressing
- Optionally with holding brake
- Protection class: IP54

## Gear unit EMGA-SST

→ 11



- Planetary gear unit
- Gear unit ratio  $i = 3$  and  $5$ , available ex-stock
- Further designs and gear ratios on request
- Life lubrication
- Protection class: IP54

## Motor controller CMMS-ST

→ Internet: cmms-st



- Positioning controller with setpoint specifications for positions, rotational speed and torque
- “Servo Lite operation” (closed loop) with encoder option, in other words no step losses, current following errors are corrected
- Interfaces:
  - I/O interface
  - CANopen
  - Profibus DP
  - DeviceNet

## Power supply units SVG

→ Internet: svg



- Robust hardware
- Input voltage 230 V AC / 115 V AC
- Output voltage 24, 48 V DC
- Output current 5, 10, 20 A

## Motor and encoder cables NEBM

→ 12



- Screened cables
- Suitable for chain link trunking
- Protection class IP67

## Axial kits EAMM

→ Internet: eamm



- Specified kits for all electromechanical axes from Festo

# Stepper motors EMMS-ST

Type codes

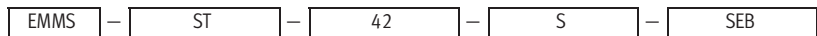

**Type**

EMMS	Motor
------	-------

**Motor type**

ST	Stepper motor
----	---------------

**Flange dimensions**

42	42 mm
57	57 mm
87	87 mm

**Gradation of the overall length**

S	Small
M	Medium
L	Large

**Additional function**

S	Straight connection
E	Encoder
B	Brake

# Stepper motors EMMS-ST

Technical data



General technical data		
Size		42
<b>Motor</b>		
Nominal voltage	[V DC]	48
Nominal current	[A]	1.8
Holding torque	[Nm]	0.5
Stepper angle	[°]	1.8 ±5%
Winding resistance	[Ω]	1.75 ±10%
Winding inductance	[mH]	5.4
Drive mass moment of inertia	[kgcm <sup>2</sup> ]	0.082/0.095 <sup>1)</sup>
Radial load on shaft	[N]	20
Axial load on shaft	[N]	7
Mass moment of inertia of rotor	[kgcm <sup>2</sup> ]	0.082
<b>Brake</b>		
Operating voltage	[V DC]	24 ±10%
Output	[W]	8
Holding torque	[Nm]	0.4
Mass moment of inertia	[kgcm <sup>2</sup> ]	0.013

1) With brake

Size		57-S	57-M
<b>Motor</b>			
Nominal voltage	[V DC]	48	
Nominal current	[A]	5	
Holding torque	[Nm]	0.8	1.4
Stepper angle	[°]	1.8 ±5%	
Winding resistance	[Ω]	0.15 ±10%	0.25 ±10%
Winding inductance	[mH]	0.5	0.95
Drive mass moment of inertia	[kgcm <sup>2</sup> ]	0.29/0.30 <sup>1)</sup>	0.48/0.5 <sup>1)</sup>
Radial load on shaft	[N]	52	
Axial load on shaft	[N]	10	
Mass moment of inertia of rotor	[kgcm <sup>2</sup> ]	0.29	0.48
<b>Brake</b>			
Operating voltage	[V DC]	24 ±10%	
Output	[W]	8	10
Holding torque	[Nm]	0.4	1
Mass moment of inertia	[kgcm <sup>2</sup> ]	0.01	0.02

1) With brake

# Stepper motors EMMS-ST

Technical data

General technical data				
Size		87-S	87-M	87-L
<b>Motor</b>				
Nominal voltage	[V DC]	48		
Nominal current	[A]	9.5		
Holding torque	[Nm]	2.5	5.9	9.3
Stepper angle	[°]	1.8 ±5%		
Winding resistance	[Ω]	0.1 ±10%	0.23 ±10%	0.23 ±10%
Winding inductance	[mH]	0.45	2.6	2.7
Drive mass moment of inertia	[kgcm <sup>2</sup> ]	1/1.07 <sup>1)</sup>	1.9/1.97 <sup>1)</sup>	3/3.07 <sup>1)</sup>
Radial load on shaft	[N]	200		
Axial load on shaft	[N]	65		
Mass moment of inertia of rotor	[kgcm <sup>2</sup> ]	1	1.9	3
<b>Brake</b>				
Operating voltage	[V DC]	24 ±10%		
Output	[W]	11		
Holding torque	[Nm]	2		
Mass moment of inertia	[kgcm <sup>2</sup> ]	0.07		

1) With brake

Technical data – Encoder	
Encoder, optical	
Operating voltage	[V DC] 5
Pulses/revolution	[rpm] 500
Zero pulse	Yes
Line driver	RS422 protocol

Weight [g]						
Size	42	57-S	57-M	87-S	87-M	87-L
Product weight	360	870	1,100	1,950	3,050	4,200
With encoder	450	970	1,200	2,100	3,200	4,350
With brake	540	1,090	1,320	2,350	3,450	4,600
With encoder and brake	600	1,150	1,380	2,500	3,600	5,000

Operating and environmental conditions	
Insulation protection class to VDE 60034	B
Protection class: motor shaft	IP54
Protection class: motor housing with connection technology	IP54
Ambient temperature	[°C] -10 ... +50
Storage temperature	[°C] -20 ... +70
CE mark (see declaration of conformity)	In accordance with EU EMC directive
Relative air humidity (non-condensing)	[%] 45 ... 80

# Stepper motors EMMS-ST

Technical data

## Pin allocation

Motor connection

Size 42, 57

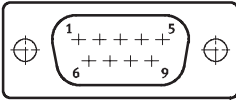

PIN	Function
1	String A
2	String A/
3	String B
4	String B/
5	-
6	-
7	Brake (24 V)
8	Brake (0 V)
9	-

Size 87

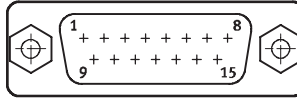

PIN	Function
1	String A
2	String A
3	String A/
4	String A/
5	String B
6	String B
7	String B/
8	String B/
9	-
10	-
11	Brake (24 V)
12	Brake (0 V)
13	-
14	-
15	-

## Encoder connection

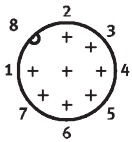

PIN	Function
1	Signal trace A
2	Signal trace A/
3	Signal trace B
4	Signal trace B/
5	0 V
6	Signal trace N
7	Signal trace N/
8	5 V

# Stepper motors EMMS-ST

Technical data

## Torque M as a function of rotational speed n

EMMS-ST-42

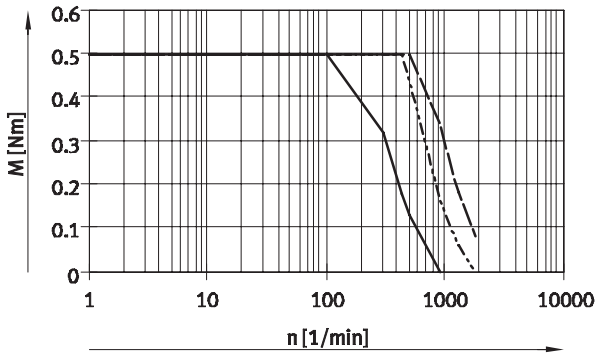

EMMS-ST-57-S

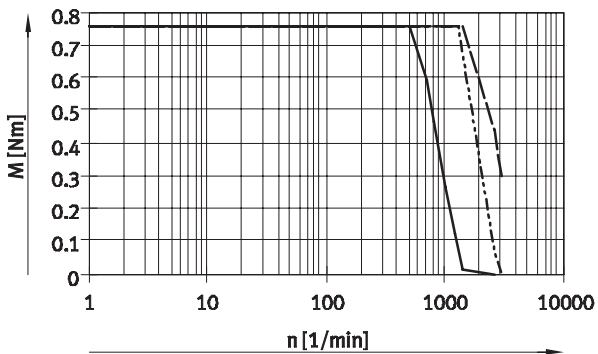

EMMS-ST-57-M

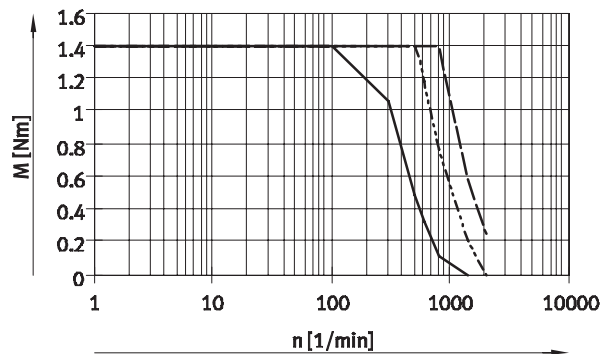

EMMS-ST-87-S

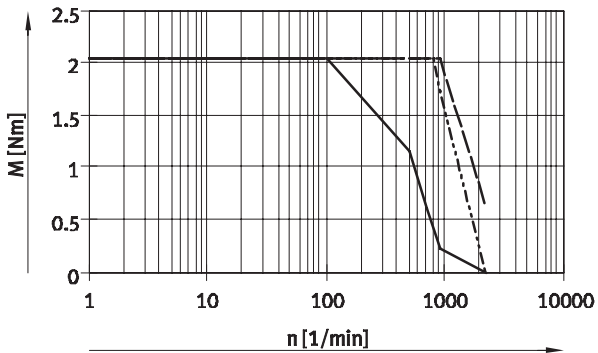

EMMS-ST-87-M

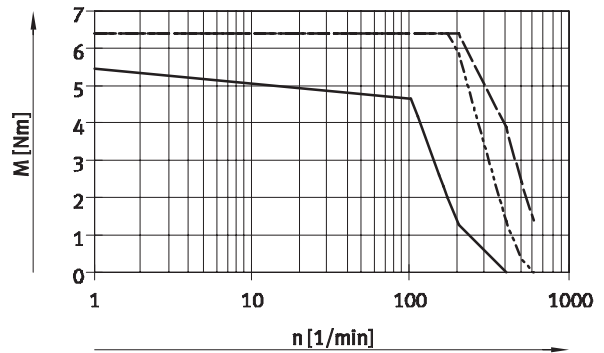

EMMS-ST-87-L

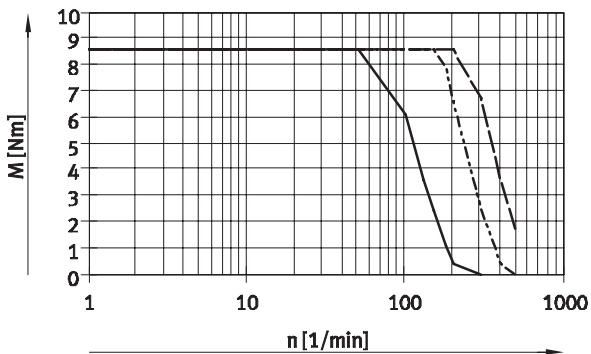

— 24VDC  
 - - - 48VDC  
 - · - 72VDC

Note

The characteristic curves apply in combination with the motor controller CMMS-ST. The size EMMS-ST-87 is operated with the motor controller CMMS-ST with max. 8 A.

# Stepper motors EMMS-ST

Technical data

**Dimensions**

Download CAD data → [www.festo.com](http://www.festo.com)

EMMS-ST-...-S

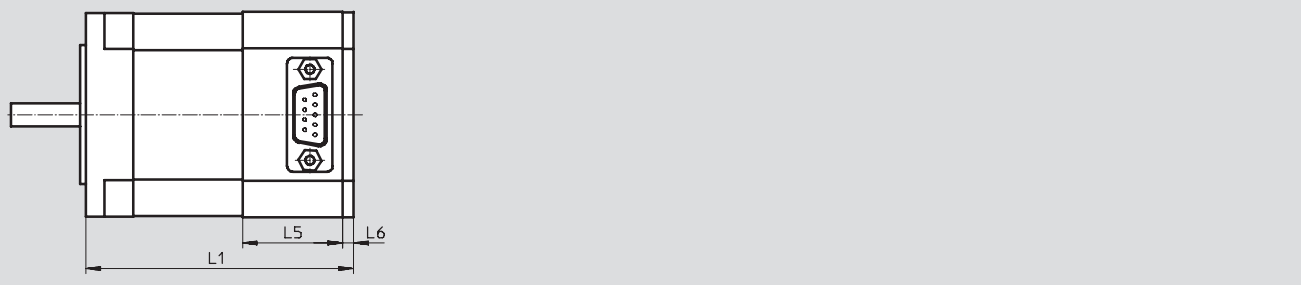

EMMS-ST-...-SB

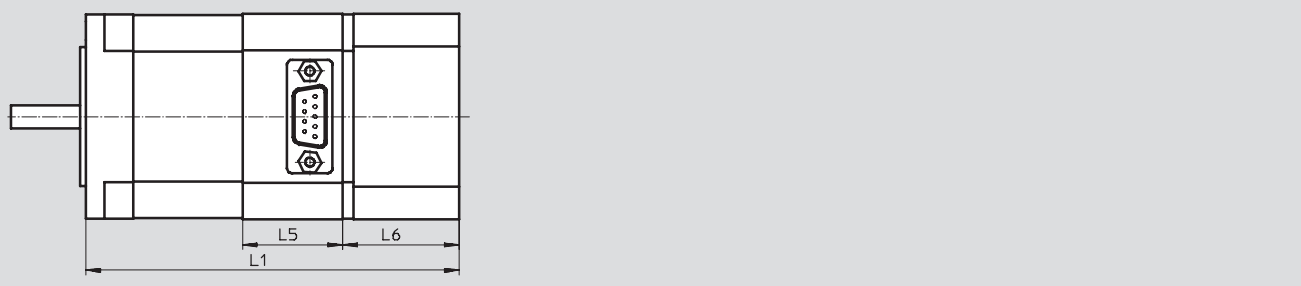

EMMS-ST-...-SE/SEB

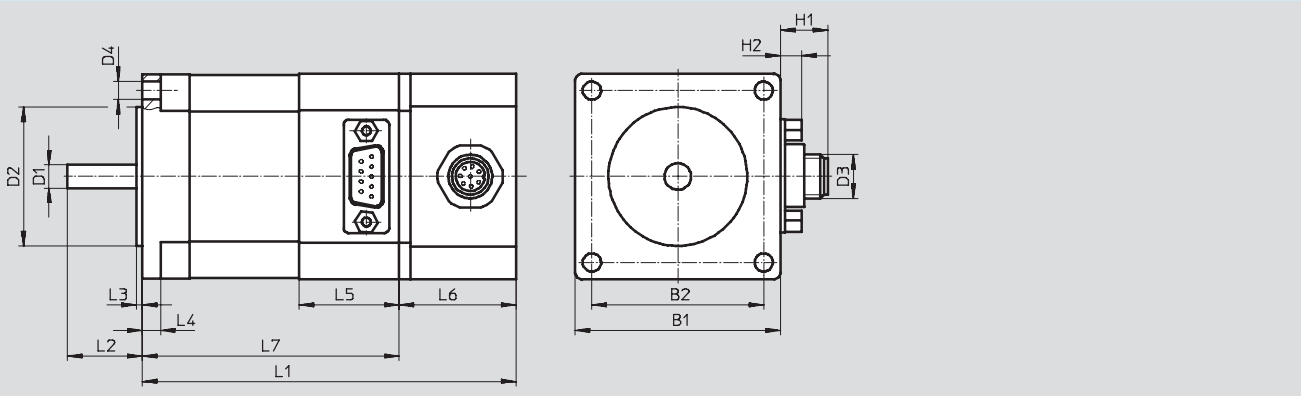

**Plug assignment**

9-pin Sub-D plug  
with size 42, 57

15-pin Sub-D plug  
with size 87

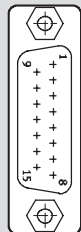
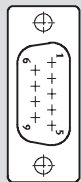



# Stepper motors EMMS-ST

Technical data

**FESTO**

Type	B1	B2	D1 ∅	D2 ∅	D3	D4 ∅	H1	H2
EMMS-ST-42-S-S	42.3	31	5-0.012	22-0.05	-	M3x4.5	-	6.5
EMMS-ST-42-S-SE					M12		13	
EMMS-ST-42-S-SB					-		-	
EMMS-ST-42-S-SEB					M12		13	
EMMS-ST-57-S-S	56.4	47.14	6.35-0.013	38.1±0.025	-	5	-	
EMMS-ST-57-S-SE					M12		13	
EMMS-ST-57-S-SB					-		-	
EMMS-ST-57-S-SEB					M12		13	
EMMS-ST-57-M-S					-		-	
EMMS-ST-57-M-SE					M12		13	
EMMS-ST-57-M-SB					-		-	
EMMS-ST-57-M-SEB					M12		13	
EMMS-ST-87-S-S	85.6	69.5	11-0.013	73-0.046	-	6.6	-	
EMMS-ST-87-S-SE					M12		13	
EMMS-ST-87-S-SB					-		-	
EMMS-ST-87-S-SEB					M12		13	
EMMS-ST-87-M-S					-		-	
EMMS-ST-87-M-SE					M12		13	
EMMS-ST-87-M-SB					-		-	
EMMS-ST-87-M-SEB					M12		13	
EMMS-ST-87-L-S					-		-	
EMMS-ST-87-L-SE					M12		13	
EMMS-ST-87-L-SB					-		-	
EMMS-ST-87-L-SEB					M12		13	

Type	L1	L2	L3	L4	L5	L6	L7
EMMS-ST-42-S-S	66	24±1	2	-	24	2	-
EMMS-ST-42-S-SE	94					30	64±1
EMMS-ST-42-S-SB	114					50	
EMMS-ST-42-S-SEB	127					63	
EMMS-ST-57-S-S	73.5	20.6±0.5	1.6	5	27.5	3	-
EMMS-ST-57-S-SE	102.5					32	70.5±0.8
EMMS-ST-57-S-SB	123.5					53	
EMMS-ST-57-S-SEB	138					64.5	
EMMS-ST-57-M-S	95					3	-
EMMS-ST-57-M-SE	124					32	92±0.8
EMMS-ST-57-M-SB	145					53	
EMMS-ST-57-M-SEB	159.5					67.5	
EMMS-ST-87-S-S	82.6	27±1	2	8.38	31.4	3	-
EMMS-ST-87-S-SE	112.6					33	79.6±1
EMMS-ST-87-S-SB	132.6					53	
EMMS-ST-87-S-SEB	152.6					73	
EMMS-ST-87-M-S	114.9					3	-
EMMS-ST-87-M-SE	144.9					33	111.9±1
EMMS-ST-87-M-SB	164.9					53	
EMMS-ST-87-M-SEB	184.9					73	
EMMS-ST-87-L-S	144.9					3	-
EMMS-ST-87-L-SE	174.9					33	141.9±1
EMMS-ST-87-L-SB	194.9					53	
EMMS-ST-87-L-SEB	214.9					73	

# Stepper motors EMMS-ST

Technical data

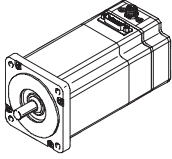
Ordering data						
	Size	Variant			Part No.	Type
		Basic version	With encoder	With brake		
	42	■			549 404	EMMS-ST-42-S-S
			■		549 405	EMMS-ST-42-S-SE
				■	549 406	EMMS-ST-42-S-SB
			■	■	549 407	EMMS-ST-42-S-SEB
	57	■			549 408	EMMS-ST-57-S-S
			■		549 409	EMMS-ST-57-S-SE
				■	549 410	EMMS-ST-57-S-SB
			■	■	549 411	EMMS-ST-57-S-SEB
		■			549 412	EMMS-ST-57-M-S
			■		549 413	EMMS-ST-57-M-SE
				■	549 414	EMMS-ST-57-M-SB
			■	■	549 415	EMMS-ST-57-M-SEB
	87	■			549 416	EMMS-ST-87-S-S
			■		549 417	EMMS-ST-87-S-SE
				■	549 418	EMMS-ST-87-S-SB
			■	■	549 419	EMMS-ST-87-S-SEB
		■			549 420	EMMS-ST-87-M-S
			■		549 421	EMMS-ST-87-M-SE
				■	549 422	EMMS-ST-87-M-SB
			■	■	549 423	EMMS-ST-87-M-SEB
		■			549 424	EMMS-ST-87-L-S
		■		549 425	EMMS-ST-87-L-SE	
			■	549 426	EMMS-ST-87-L-SB	
		■	■	549 427	EMMS-ST-87-L-SEB	

# Stepper motors EMMS-ST

Accessories

## Gear unit EMGA

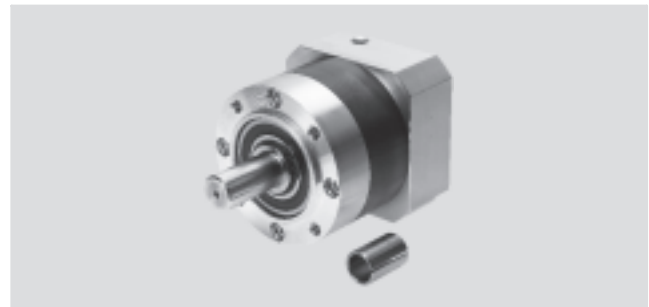

General technical data							
For motor size		42		57		87	
Gear unit type		EMGA-40-P-G...		EMGA-60-P-G...		EMGA-80-P-G...	
Gear unit ratio		[i]					
Continuous output torque <sup>1)</sup>	[Nm]	11	14	22	22	85	110
Max. drive torque	[Nm]	17.6	22	22	22	136	176
Torsional resistance	[Nm/arcmin]	1		2.3		6	
Torsional backlash	[deg]	0.4		0.27		0.15	
Moment of inertia <sup>2)</sup>	[kgcm <sup>2</sup> ]	0.031	0.19	0.135	0.078	0.77	0.45
Efficiency	[%]	96					
Operating temperature <sup>3)</sup>	[°C]	-25 ... +90					
Protection class		IP54					

- 1) At the drive shaft
- 2) Referred to the drive shaft
- 3) Note the temperature range of the motor

## Dimensions Download CAD data → [www.festo.com](http://www.festo.com)

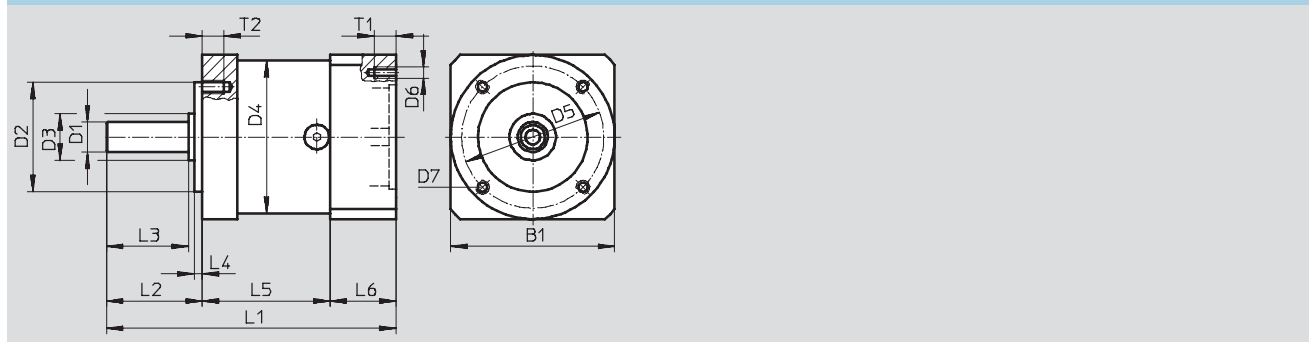

For size	B1	D1	D2	D3	D4	D5	D6	D7	L1	L2	L3	L4	L5	L6	T1	T2
		∅	∅	∅	∅	∅										
		h7	h7						±1.5		±0.2	±0.2				
42	40	10	26	12	40	34	∅3.4	M4	92.5	26±0.6	23	2	39	27.5	5	6
57	60	11	40	17	60	52	M4	M5	106	35±0.8	30	3	47	24	8	8
87	90	20	60	25	80	70	M5	M6	135.5	40±0.8	36	3	60	35.5	12	10

Ordering data			
For size	Gear unit ratio	Part No.	Type
42	3	549 428	EMGA-40-P-G3-SST-42
	5	549 429	EMGA-40-P-G5-SST-42
57	3	549 430	EMGA-60-P-G3-SST-57
	5	549 431	EMGA-60-P-G5-SST-57
87	3	549 432	EMGA-80-P-G3-SST-87
	5	549 433	EMGA-80-P-G5-SST-87

# Stepper motors EMMS-ST

Accessories

Technical data – Cables			
Designation	Motor cable		Encoder cable
Type	NEBM-S1G9-...	NEBM-S1G15-...	NEBM-M12G8-...
For size	EMMS-ST-42/57	EMMS-ST-87	EMMS-ST-42/57/87
Min. bending radius [mm]	58	70	51
Ambient temperature [°]	-40 ... +70	-30 ... +70	-40 ... +70
Ambient temperature <sup>1)</sup> [°]	-40 ... +70	-5 ... +70	-40 ... +70
Cable design	Screened		
Cable attribute	Suitable for drag chain		
Protection class	IP65		
Material	Polyurethane		

1) with flexible cable installation

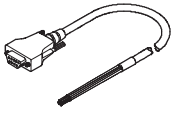
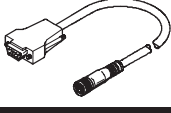
Ordering data			
	Cable length [m]	Part No.	Type
<b>Motor cable</b>			
	For EMMS-ST-42/57		
	5	550 740	NEBM-S1G9-E-5-LE6
	10	550 741	NEBM-S1G9-E-10-LE6
	15	550 742	NEBM-S1G9-E-15-LE6
	X length <sup>1)</sup>	550 743	NEBM-S1G9-E-...-LE6
	For EMMS-ST-87		
	5	550 744	NEBM-S1G15-E-5-LE6
	10	550 745	NEBM-S1G15-E-10-LE6
	15	550 746	NEBM-S1G15-E-15-LE6
	X length <sup>1)</sup>	550 747	NEBM-S1G15-E-...-LE6
<b>Encoder cable</b>			
	5	550 748	NEBM-M12G8-E-5-S1G9
	10	550 749	NEBM-M12G8-E-10-S1G9
	15	550 750	NEBM-M12G8-E-15-S1G9
	X length <sup>1)</sup>	550 751	NEBM-M12G8-E-...-S1G9

1) Max. 25 m