

Electric slides EGSK/EGSP

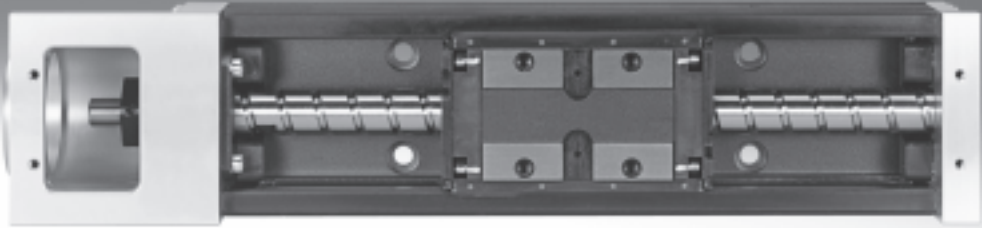

# Electric slides EGSK/EGSP

Key features

## At a glance

### Precision embedded in steel

The new generation of electric slide axes EGSK and EGSP impresses with its precision, repetition accuracy, compactness and rigidity.

The two axis series form a complete range with a uniform design, long service life and standardised mounting interfaces. The U-shaped steel housing serves simultaneously as

a guide rail. The slide combines linear guide elements and the spindle nuts of the ball screw in one component, thus avoiding the accumulation of production tolerances.

Both series come in three accuracy classes with the option of an additional slide (series 33 and 46 are also available in a short-slide design).

### Electric slide EGSK

- Recirculating ball bearing guide and ball screw without caged balls
- Standard designs available ex-stock

### Electric slide EGSP

- Recirculating ball bearing guide with caged balls
- Size 33, 46 features a ball screw with caged balls
- Low-maintenance
- Uniform operating behaviour with very low noise levels

## Linear guide with caged balls

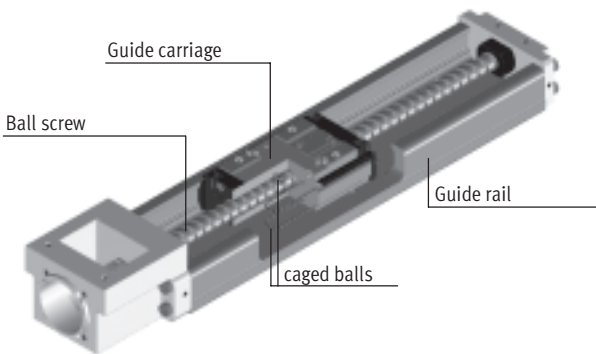

The linear guide features four rows of balls circulating within the guide carriage. In the loaded area, the balls run between the honed grooves of the guide carriage and guide rail until they are returned by means of the reversers in the end plates and the return channels. The very rigid design of the guide carriage enables precision

linear movements to be executed with impressive dynamism. The four rows of balls are arranged at a contact angle of 45°, giving the guide carriage the same basic load ratings in both radial coordinate directions. This type of guide can therefore be used in any mounting position for a wide range of load directions.

## Axis characteristics

The specifications shown in the table are maximum values.

The precise values for each of the variants can be found in the relevant technical data section.

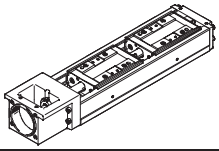
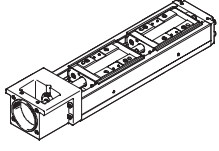
Design	Size	Working stroke [mm]	Speed [m/s]	Repetition accuracy [µm]	Feed force [N]	Guide characteristics				
						Forces and torques				
						Fy [N]	Fz [N]	Mx [Nm]	My [Nm]	Mz [Nm]
<b>Electric slide EGSK</b>						<b>→ 6</b>				
	15	25 ... 100	0.33	±3	57	1,185	1,185	13	3.7	3.7
	20	25 ... 125	1.10	±3	133	2,204	2,204	28.7	9.2	9.2
	26	50 ... 200	0.83	±3	184	3,528	3,528	60	20.4	20.4
	33	100 ... 630	1.10	±3	239	3,920	3,920	79.5	26	26
	46	200 ... 840	1.48	±3	392	7,809	7,809	231	77.3	77.3
<b>Electric slide EGSP</b>						<b>→ 22</b>				
	20	25 ... 125	0.6	±3	112	2,929	2,929	36.3	12.5	12.5
	26	50 ... 200	0.6	±3	212	5,028	5,028	81.5	31.6	31.6
	33	100 ... 630	2	±3	466	4,559	4,559	90.3	32.1	32.1
	46	200 ... 840	2	±3	460	8,935	8,935	258	94	94

# Electric slides EGSK/EGSP

Key features

**Complete system comprising electric slide, motor, motor controller and motor mounting kit**  
 Electric slide with recirculating ball bearing guide



## Motor

→ 26



- 1 Servo motor EMMS-AS
- 2 Stepper motor EMMS-ST



Note

A range of specially matched complete solutions is available for the electric slides EGSK, EGSP and the motors.

## Motor controller

Technical data → Internet: motor controller



- 1 Servo motor controller CMMP-AS, CMMS-AS
- 2 Stepper motor controller CMMS-ST

## Motor mounting kit

→ 26

Axial kit



Kit comprising:

- Motor flange
- Coupling
- Screws

# Electric slides EGSK/EGSP

Peripherals overview

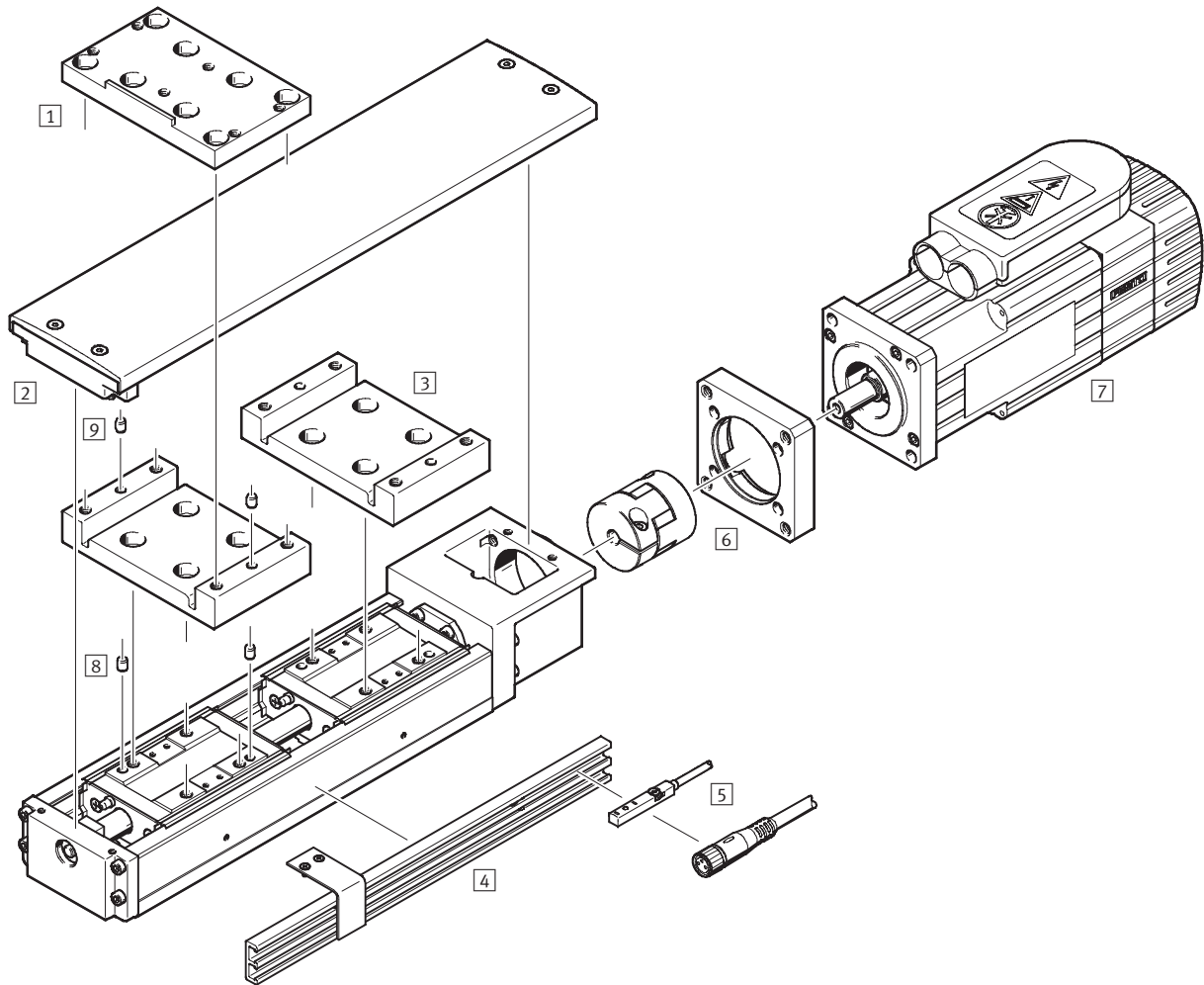

## Electric slides EGSK/EGSP

Peripherals overview

Accessories		
Type	Brief description	→ Page/Internet
1 Cross connecting kit EHAM-S1	For mounting an assembly axis EGSK/EGSP at right angles on the slide of a basic axis EGSK/EGSP. The assembly axis is one size smaller than the respective basic axis.	38
2 Covering kit EASC-S1	For covering the axis profile that is open at the top. The kit includes a slide adapter EASA-S1.	40
3 Slide adapter EASA-S1	Required to mount the effective load in combination with the covering kit for axis variants with additional slide.	39
4 Sensor strip EAPR-S1-S	<ul style="list-style-type: none"> <li>For mounting the inductive proximity sensor SIES-8M on the electric slide.</li> <li>Switching lugs are included in the scope of delivery.</li> </ul>	42
5 Proximity sensor SIES-8M	Inductive proximity sensor, for T-slot.	43
6 Axial kit EAMM-A	For axial motor mounting (comprising: coupling and motor flange).	35
7 Motor EMMS	Motors specially matched to the axis, with or without brake.	35
8 Centring pin ZBS	For centring loads and attachments on the slide.	43
9 Centring pin ZBS	For centring loads and attachments on the slide adapter.	43

# Electric slides EGSK

Type codes



		EGSK	-	20	-	125	-	6P	-	H	-		-	Z
<b>Type</b>														
EGSK	Electric slide													
<b>Size</b>														
<b>Stroke [mm]</b>														
<b>Spindle pitch</b>														
<b>Accuracy</b>														
-	Standard													
H	High accuracy													
P	Precision design													
<b>Slide design</b>														
-	Standard slide													
S	Slide, short													
<b>Additional slide</b>														
-	No additional slide													
Z	Additional slide													

# Electric slides EGSK

Technical data

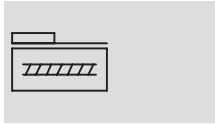
Function



-  - Size  
15 ... 46
-  - Stroke length  
25 ... 840 mm



General technical data													
Size		15 <sup>2)</sup>		20		26		33		46			
Spindle pitch		1	2	1	6	2	6	6	10	10	20		
		Code <sup>1)</sup>											
Constructional design		Electromechanical linear axis with recirculating ball bearing spindle											
Guide		Recirculating ball bearing guide											
Installation position		Any											
Type of mounting for effective load		Female thread											
		Centring sleeve				Locating pin							
Working stroke <sup>3)</sup>	-	[mm]		25 ... 100		25 ... 125		50 ... 200		100 ... 600		200 ... 800	
	S	[mm]		-		-		-		130 ... 630		240 ... 840	
Max. feed force	-/H <sup>4)</sup>	[N]		36	19	69	72	116	116	150	148	264	192
F <sub>x,max</sub>	P <sup>5)</sup>	[N]		57	31	110	133	184	184	239	183	392	343
Max. driving torque	-/H <sup>4)</sup>	[Ncm]		0.6	0.6	1.1	6.9	3.7	11	14	24	42	61
M <sub>Driving,max</sub>	P <sup>5)</sup>	[Ncm]		0.9	1.0	1.8	13	5.9	18	23	29	62	109
No-load torque	-/H	[Ncm]		0.4	0.4	0.5	0.5	1.5	1.5	7	7	10	10
M <sub>No-load</sub>	P	[Ncm]		0.8	0.8	1.2	1.2	4.0	4.0	15	15	17	17
Max. rotational speed <sup>6)</sup>		[1/min]		9,600	9,900	11,400	7,900	8,400	5,900	4,700	4,700	3,100	3,100
Max. speed <sup>6)</sup>	-/H	[m/s]		0.16	0.33	0.19	0.79	0.28	0.59	0.47	0.79	0.52	1.05
	P	[m/s]		0.16	0.33	0.19	1.10	0.28	0.83	0.66	1.10	0.74	1.48
Max. acceleration		[m/s <sup>2</sup> ]		10		10		10		20		20	
Homing		Inductive proximity sensor SIES-8M											

- 1) Variant code → 6
- 2) Size 15 only comes in the accuracy classes H and P
- 3) Maximum travel distance → 15  
In combination with an additional slide, the working stroke is reduced by the length of the additional slide and the distance between the two slides
- 4) Loads are based on a service life specification of 5 x 10<sup>8</sup> rotations
- 5) Loads are based on a service life specification of 1.25 x 10<sup>8</sup> rotations
- 6) Reduced speeds with sizes 33 and 46 with long strokes → 9

Operating and environmental conditions		
Ambient temperature	[°C]	0 ... +40
Relative air humidity	[%]	0 ... 95 (non-condensing)

Weight [kg]											
Size		15		20		26		33		46	
		Code <sup>1)</sup>									
Basic weight with 0 mm stroke <sup>2)</sup>	-			0.16	0.38	0.78	1.38	5.17			
	S			-	-	-	1.28	4.77			
Additional weight per 100 mm stroke	-			0.12	0.27	0.42	0.63	1.27			
Moving load	-			0.04	0.07	0.15	0.31	0.91			
	S			-	-	-	0.17	0.57			
Additional slide Z	-			0.04	0.07	0.15	0.31	0.91			
	S			-	-	-	0.17	0.57			

- 1) Variant code → 6
- 2) Including slide, without additional slide

# Electric slides EGSK

Technical data

Accuracy data [µm]			15		20		26		33		46	
Size	Stroke	Code <sup>1)</sup>										
Repetition accuracy <sup>2)</sup>		–	–	–	±10	±10	±10	±10	±10	±10	±10	±10
		H	±4	±5	±5	±5	±5	±5	±5	±5	±5	±5
		P	±3	±3	±3	±3	±3	±3	±3	±3	±3	±3
Operating parallelism	25 ... 340	H	20	25	25	25	25	25	25	25	25	35
	400 ... 540	H	–	–	–	–	–	–	–	–	–	35
	600 ... 640	H	–	–	–	–	–	–	–	–	–	40
	800 ... 840	H	–	–	–	–	–	–	–	–	–	50
	25 ... 340	P	10	10	10	10	10	10	10	10	10	15
	400 ... 540	P	–	–	–	–	–	–	–	–	–	15
	600 ... 640	P	–	–	–	–	–	–	–	–	–	20
Max. reversing play		–	–	–	20	20	20	20	20	20	20	20
		H	10	10	10	10	10	10	10	10	10	20
		P	2	3	3	3	3	3	3	3	3	3

1) Variant code → 6

2) The repetition accuracy that can be achieved with a motor/axis system is also influenced by the angle resolution of the motor and the chosen control parameters. The specified repetition accuracy cannot, therefore, be achieved with all motors.

## Materials

Sectional view

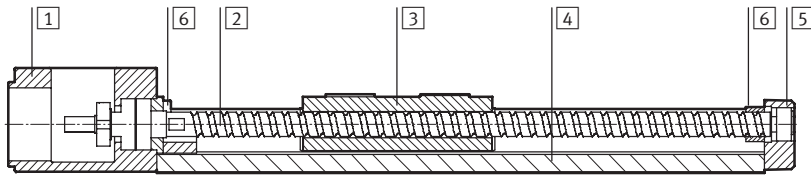

Electric slide	
1 Drive cover	Die-cast aluminium, coated
2 Spindle	Steel
3 Slide	Steel
4 Profile	High-alloy steel
5 End cap	Die-cast aluminium, coated
6 Buffer	Ethylene vinyl acetate copolymer
Note on materials	RoHS-compliant
	Contains PWIS (paint-wetting impairment substances)

Mass moment of inertia											
Size		15		20		26		33		46	
Spindle pitch		1	2	1	6	2	6	6	10	10	20
	Code <sup>1)</sup>										
J <sub>0</sub>	[kg mm <sup>2</sup> ]	0.030	0.033	0.087	0.143	0.355	0.479	1.15	1.65	8.43	15.3
	S [kg mm <sup>2</sup> ]	–	–	–	–	–	–	0.791	1.07	6.01	10.3
J <sub>S</sub> per 100 mm stroke	[kg mm <sup>2</sup> /100 mm]	0.048		0.099		0.314		0.766		3.877	
J <sub>L</sub> per kg effective load	[kg mm <sup>2</sup> /kg]	0.03	0.10	0.03	0.91	0.10	0.91	0.91	2.53	2.53	10.13
J <sub>W</sub> per additional slide	[kg mm <sup>2</sup> ]	0.001	0.004	0.002	0.058	0.016	0.14	0.28	0.79	2.31	9.22
	S [kg mm <sup>2</sup> ]	–	–	–	–	–	–	0.16	0.43	1.44	5.78

1) Variant code → 6

The mass moment of inertia J<sub>A</sub> of the entire axis is calculated as follows:

$$J_A = J_0 + J_W + J_S \times \text{working stroke} + J_L \times m_{\text{Effective load}}$$



# Electric slides EGSK

Technical data

## Speed v, rotational speed n as a function of working stroke l

EGSK-33-...-6P

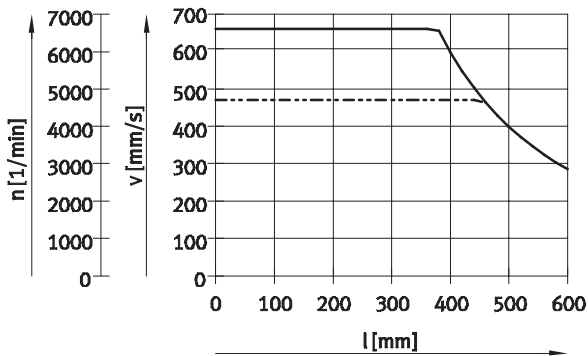

— EGSK-33-...-6P-P  
 - - - - EGSK-33-...-6P, EGSK-33-...-6P-H

EGSK-33-...-10P

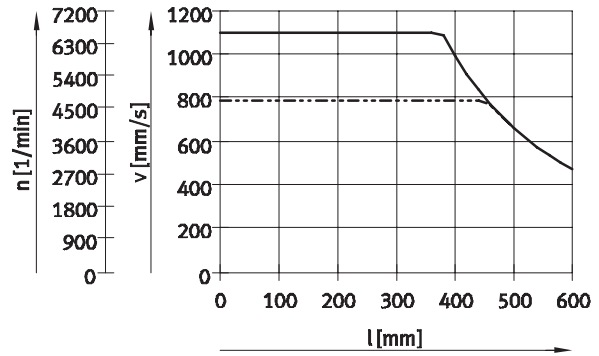

— EGSK-33-...-10P-P  
 - - - - EGSK-33-...-10P, EGSK-33-...-10P-H

EGSK-46-...-10P

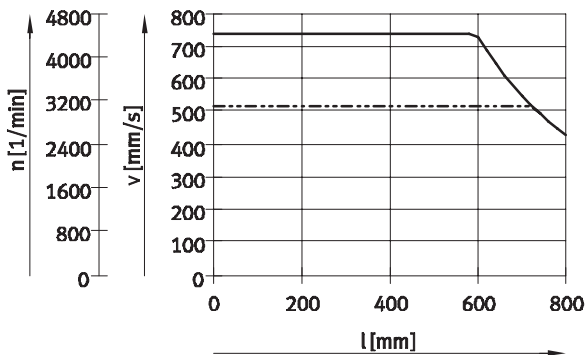

— EGSK-46-...-10P-P  
 - - - - EGSK-46-...-10P, EGSK-46-...-10P-H

EGSK-46-...-20P

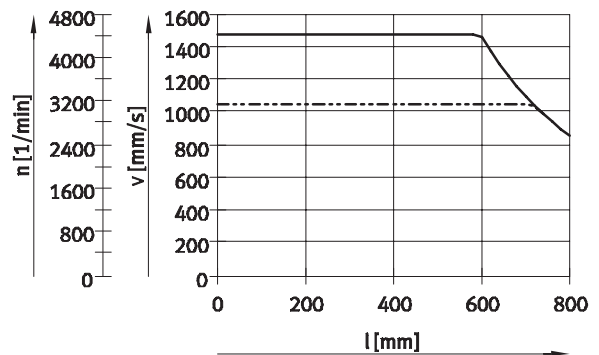

— EGSK-46-...-20P-P  
 - - - - EGSK-46-...-20P, EGSK-46-...-20P-H

## 2nd moment of area

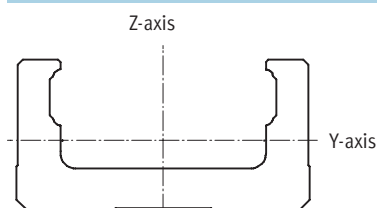

Size		15	20	26	33	46
ly	[mm <sup>4</sup> ]	908	6,100	17,000	62,000	240,000
lz	[mm <sup>4</sup> ]	14,200	62,000	150,000	380,000	1,500,000

# Electric slides EGSK

Technical data

## Characteristic load values

The indicated forces and torques refer to the centre axis of the spindle.  
The coordinate zero point is the point where the centre of the guide and the longitudinal centre of the slide intersect.

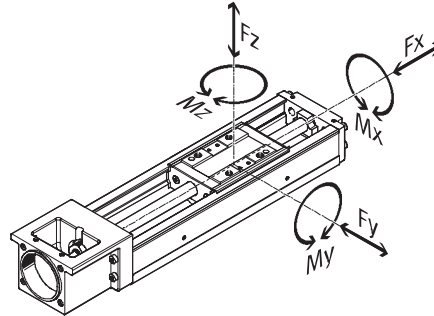

 Note  
PositioningDrives  
sizing software  
www.festo.com

Permissible forces and torques <sup>1)</sup>			15 <sup>3)</sup>		20		26		33		46	
Size			1	2	1	6	2	6	6	10	10	20
Spindle pitch												
	Code <sup>2)</sup>											
F <sub>y</sub> max., F <sub>z</sub> max.	-/H <sup>4)</sup>	- [N]	747	593	1,389	764	2,223	1,541	2,469	2,083	4,919	3,904
	P <sup>5)</sup>	- [N]	1,185	941	2,204	1,213	3,528	2,446	3,920	3,306	7,809	6,198
	-/H <sup>4)</sup>	S [N]	-	-	-	-	-	-	1,043	880	2,514	1,995
	P <sup>5)</sup>	S [N]	-	-	-	-	-	-	1,656	1,396	3,990	3,167
M <sub>x</sub> max.	-/H <sup>4)</sup>	- [Nm]	8.2	6.5	18.1	9.9	37.8	26.2	50.1	42.2	145	115
	P <sup>5)</sup>	- [Nm]	13	10.3	28.7	15.8	60	41.6	79.5	67.1	231	183
	-/H <sup>4)</sup>	S [Nm]	-	-	-	-	-	-	21.2	17.8	74.4	59
	P <sup>5)</sup>	S [Nm]	-	-	-	-	-	-	33.6	28.3	118	93.7
M <sub>y</sub> max., M <sub>z</sub> max.	-/H <sup>4)</sup>	- [Nm]	2.3	1.9	5.8	3.2	12.9	8.9	16.4	13.8	48.7	38.7
	P <sup>5)</sup>	- [Nm]	3.7	2.9	9.2	5.1	20.4	14.1	26	21.9	77.3	61.4
	-/H <sup>4)</sup>	S [Nm]	-	-	-	-	-	-	3.8	3.2	13.6	10.8
	P <sup>5)</sup>	S [Nm]	-	-	-	-	-	-	6	5	21.6	17.1

- 1) Calculated with a speed-dependent load factor  $f_w$  of 1.2
- 2) Variant code → 6
- 3) Size 15 only comes in the accuracy classes H and P
- 4) Loads are based on a service life specification of  $5 \times 10^8$  rotations and a load factor  $f_w$  of 1.2
- 5) Loads are based on a service life specification of  $1.25 \times 10^8$  rotations and a load factor  $f_w$  of 1.2

Basic load ratings			15 <sup>2)</sup>		20		26		33		46	
Size			1	2	1	6	2	6	6	10	10	20
Spindle pitch												
	Code <sup>1)</sup>											
Ball screw												
Static C <sub>0</sub> ball screw	-/H	[N]	660	410	1,170	1,450	4,020	3,510	4,900	2,840	6,760	7,150
	P	[N]	660	410	1,170	1,600	4,020	3,900	2,740	1,570	3,720	5,290
Dynamic C <sub>dyn</sub> ball screw	-/H <sup>3)</sup>	[N]	340	230	660	860	2,350	1,950	2,840	1,760	3,140	3,040
	P <sup>3)</sup>	[N]	340	230	660	1,060	2,350	2,390	2,250	1,370	2,940	3,430
Fixed bearing												
Static C <sub>0</sub> bearing		[N]	290		1,240		1,760		2,590		3,240	
Dynamic C <sub>dyn</sub> bearing <sup>3)</sup>		[N]	590		1,000		1,380		1,790		6,660	

- 1) Variant code → 6
- 2) Size 15 only comes in the accuracy classes H and P
- 3) Dynamic basic load ratings are based on a basic service life of  $10^6$  rotations

# Electric slides EGSK

Technical data

**FESTO**

Basic load ratings											
Size		15 <sup>2)</sup>		20		26		33		46	
Spindle pitch		1	2	1	6	2	6	6	10	10	20
		Code <sup>1)</sup>									
Linear guide											
Static C <sub>0,guide</sub>	-	[N]	3,450	6,300	12,150	20,200	45,500				
	S	[N]	-	-	-	10,000	22,700				
Dynamic c <sub>dyn,guide</sub> <sup>3)</sup>	-	[N]	1,532	2,849	5,746	9,207	21,747				
	S	[N]	-	-	-	3,889	11,112				
Torque equivalence factors											
k <sub>x</sub>	-	[1/m]	90.9	76.9	58.8	49.3	33.8				
	S	[1/m]	-	-	-	49.3	33.8				
k <sub>y</sub> , k <sub>z</sub>	-	[1/m]	319.9	238.7	172.9	151	101				
	S	[1/m]	-	-	-	277.1	185				

1) Variant code → 6

2) Size 15 only comes in the accuracy classes H and P

3) Dynamic basic load ratings are based on a basic service life of 100 km

## Speed-dependent load factor f<sub>w</sub>

f<sub>w</sub> = 1.0 ... 1.2 (v ≤ 0.25 m/s)

f<sub>w</sub> = 1.2 ... 1.5 (0.25 m/s ≤ v ≤ 1.0 m/s)

f<sub>w</sub> = 1.5 ... 2.0 (1.0 m/s ≤ v ≤ 2.0 m/s)

f<sub>w</sub> = 2.0 ... 3.5 (v ≥ 2.0 m/s)

## Calculation of the maximum feed force F<sub>x</sub>

$$F_{x,max} = \frac{1}{f_w} \times \frac{\text{Min}[C_{dyn,KGT}; C_{dyn,bearing}]}{\sqrt[3]{\frac{L_{ref,rot}}{10^6}}}$$

## Calculation of the maximum forces F<sub>y/z</sub> and torques M<sub>x/y/z</sub>

$$F_{y/z,max} = \frac{1}{f_w} \times \frac{C_{dyn,guide}}{\sqrt[3]{\frac{L_{ref,km}}{100km}}}$$

$$M_{x/y/z,max} = \frac{1}{k_{x/y/z}} \times \frac{1}{f_w} \times \frac{C_{dyn,guide}}{\sqrt[3]{\frac{L_{ref,km}}{100km}}}$$

# Electric slides EGSK

Technical data

## Calculation of the service life

Size	15		20		26		33		46		
Spindle pitch P	1	2	1	6	2	6	6	10	10	20	
	Code <sup>1)</sup>										
Reference service life	-/H	5 x 10 <sup>8</sup>									
in rotations, L <sub>ref,rot</sub>	P	1.25 x 10 <sup>8</sup>									
Reference service life	-/H [km]	500	1,000	500	3,000	1,000	3,000	3,000	5,000	5,000	10,000
in kilometres, L <sub>ref,km</sub>	P [km]	125	250	125	750	250	750	750	1,250	1,250	2,500

1) Variant code → 6

### 1 Representation of the loads

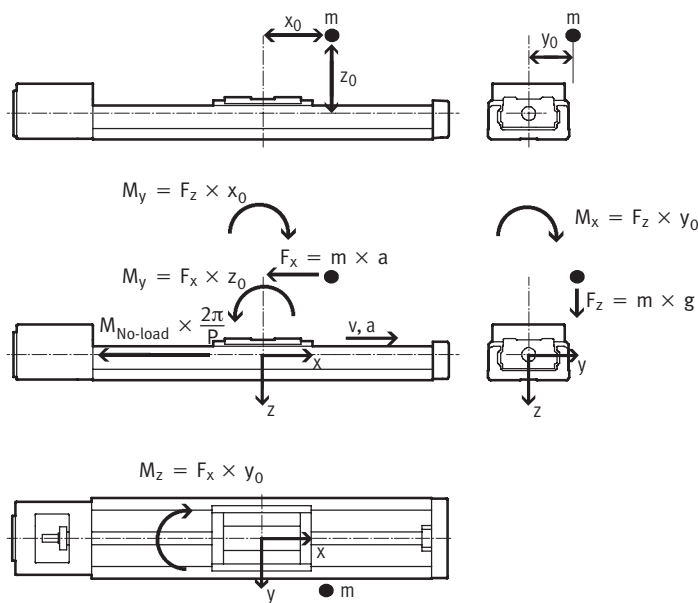

### 2 Determination of the loads over the travel cycle

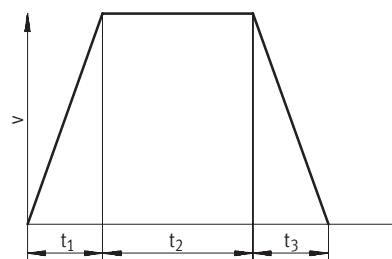

$$q_1 = \frac{t_1}{t_{tot}} \quad q_2 = \frac{t_2}{t_{tot}} \quad q_3 = \frac{t_3}{t_{tot}}$$

$$t_{tot} = t_1 + t_2 + t_3$$

v	Speed
t <sub>1</sub>	Acceleration time
t <sub>2</sub>	Constant travel time
t <sub>3</sub>	Deceleration time
q <sub>1/2/3</sub>	Relative time of the cycle phases
t <sub>tot</sub>	Cycle time

### Ball screw

For t<sub>1</sub>:  $F_{x1} = - (m \times a) - (M_{No-load} \times \frac{2\pi}{P})$

For t<sub>2</sub>:  $F_{x2} = - (M_{No-load} \times \frac{2\pi}{P})$

For t<sub>3</sub>:  $F_{x3} = m \times a - (M_{No-load} \times \frac{2\pi}{P})$

F <sub>x1/2/3</sub>	Calculated force load per cycle phase
F <sub>x,dyn</sub>	Calculated average force load
m	Effective load (centre of gravity)
a	Acceleration
M <sub>No-load</sub>	No-load torque → 7
P	Spindle pitch → 7
q <sub>1/2/3</sub>	Relative time of the cycle phases

# Electric slides EGSK

Technical data

## 2 Determination of the loads over the travel cycle

### Linear guide

**For t<sub>1</sub>: a →, v →**

$$F_{y1} = 0$$

$$F_{z1} = m \times g$$

$$M_{x1} = F_z \times y_0 = m \times g \times y_0$$

$$M_{y1} = -F_z \times x_0 + F_x \times z_0 = -m \times g \times x_0 + m \times a \times z_0$$

$$M_{z1} = F_x \times y_0 = m \times a \times y_0$$

**For t<sub>2</sub>: a = 0, v →**

$$F_{y2} = 0$$

$$F_{z2} = m \times g$$

$$M_{x2} = F_z \times y_0 = m \times g \times y_0$$

$$M_{y2} = -F_z \times x_0 = -m \times g \times x_0$$

$$M_{z2} = 0$$

**For t<sub>3</sub>: a ←, v →**

$$F_{y3} = 0$$

$$F_{z3} = m \times g$$

$$M_{x3} = F_z \times y_0 = m \times g \times y_0$$

$$M_{y3} = -F_z \times x_0 - F_x \times z_0 = -m \times g \times x_0 - m \times a \times z_0$$

$$M_{z3} = -F_x \times y_0 = -m \times a \times y_0$$

$$F_{y,dyn} = \sqrt[3]{q_1 \times |F_{y1}|^3 + q_2 \times |F_{y2}|^3 + q_3 \times |F_{y3}|^3}$$

$$F_{z,dyn} = \sqrt[3]{q_1 \times |F_{z1}|^3 + q_2 \times |F_{z2}|^3 + q_3 \times |F_{z3}|^3}$$

$$M_{x,dyn} = \sqrt[3]{q_1 \times |M_{x1}|^3 + q_2 \times |M_{x2}|^3 + q_3 \times |M_{x3}|^3}$$

$$M_{y,dyn} = \sqrt[3]{q_1 \times |M_{y1}|^3 + q_2 \times |M_{y2}|^3 + q_3 \times |M_{y3}|^3}$$

$$M_{z,dyn} = \sqrt[3]{q_1 \times |M_{z1}|^3 + q_2 \times |M_{z2}|^3 + q_3 \times |M_{z3}|^3}$$

## 3 Total load

### Ball screw

$$\frac{|F_{x,dyn}|}{F_{x,max}} \leq f_v$$

$F_{x,dyn}$	Calculated average force load
$F_{x,max}$	Max. permissible force load → 7
$f_v$	Load comparison factor → 14

### Linear guide

$$\frac{|F_{y,dyn}|}{F_{y,max}} + \frac{|F_{z,dyn}|}{F_{z,max}} + \frac{|M_{x,dyn}|}{M_{x,max}} + \frac{|M_{y,dyn}|}{M_{y,max}} + \frac{|M_{z,dyn}|}{M_{z,max}} \leq f_v$$

$F_{y/z,dyn}$	Calculated average force load
$F_{y/z,max}$	Max. permissible force load → 10
$M_{x/y/z,dyn}$	Calculated average torque load
$M_{x/y/z,max}$	Max. permissible torque load → 10
$f_v$	Load comparison factor → 14

# Electric slides EGSK

Technical data

## 4 Determination of the load comparison factor $f_v$

$$f_v = \frac{1}{\sqrt[3]{q}} \quad \text{with} \quad q = \frac{L_{\text{calc,km}}}{L_{\text{ref,km}}} = \frac{L_{\text{calc,rot}}}{L_{\text{ref,rot}}}$$

for  $q = 1$ :

Calculated service life (here desired service life)  $L_{\text{calc,km}} = 1 \times$  reference service life  $L_{\text{ref,km}}$  gives  $f_v = 1$

for  $q \neq 1$ :

Calculated service life (here desired service life)  $L_{\text{calc,km}} = q \times$  reference service life  $L_{\text{ref,km}}$  read off (→ graph) or calculate  $f_v$

$f_v$	Load comparison factor
$q$	Quotient of desired service life divided by reference service life
$L_{\text{calc, km}}$	Calculated service life in km
$L_{\text{ref, km}}$	Reference service life in km → 12
$L_{\text{calc, rot}}$	Calculated service life in rotations
$L_{\text{ref, rot}}$	Reference service life in rotations → 12

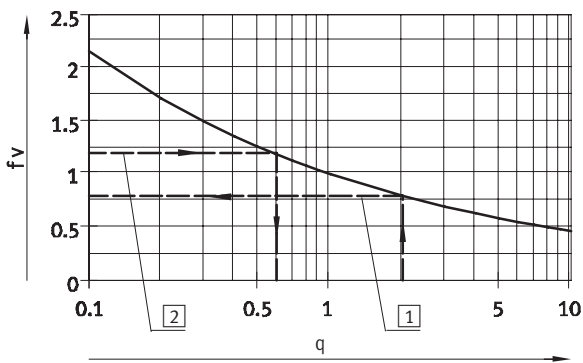

- 1 → Example 1
- 2 → Example 2

## 5 Calculation examples

Example 1:

EGSK-26-...-2P-H-...  
 $L_{\text{ref,km}} = 1,000 \text{ km}$   
 $L_{\text{calc,km}} = 2,000 \text{ km}$   
 $q = \frac{2000\text{km}}{1000\text{km}} = 2.0$   
 $f_v = \frac{1}{\sqrt[3]{q}} = 0.79$

Result:  
 A desired service life of 200% of the reference service life means that the permissible total load must be 21% lower.

Example 2:

If the total load calculation gives a load comparison factor  $f_v$  of 1.2, the mathematical service life is only approx. 60% ( $x = 0.6$  → graph) of the reference service life.

$$q = \frac{1}{f_v^3} = 0.58$$

## 6 Static sizing

Ball screw

$$F_{x,\text{stat}} = \text{Max}[F_{x1}, F_{x2}, F_{x3}] \leq \frac{C_{0,\text{KGT}}}{f_s}$$

$F_{x,\text{stat}}$	Maximum value of the calculated force load per cycle phase
$F_{x1/2/3}$	Calculated force load per cycle phase

$C_{0,\text{KGT}}$	Static basic load rating of ball screw → 10
$f_s$	Safety factor against static overload $f_s = 1.0 \dots 3.0$

Linear guide

$$F_{y,\text{stat}} = \text{Max}[F_{y1}, F_{y2}, F_{y3}] \leq \frac{C_{0,\text{guide}}}{f_s}$$

$$F_{z,\text{stat}} = \text{Max}[F_{z1}, F_{z2}, F_{z3}] \leq \frac{C_{0,\text{guide}}}{f_s}$$

$$M_{x,\text{stat}} = \text{Max}[M_{x1}, M_{x2}, M_{x3}] \leq \frac{1}{k_x} \times \frac{C_{0,\text{guide}}}{f_s}$$

$$M_{y,\text{stat}} = \text{Max}[M_{y1}, M_{y2}, M_{y3}] \leq \frac{1}{k_y} \times \frac{C_{0,\text{guide}}}{f_s}$$

$$M_{z,\text{stat}} = \text{Max}[M_{z1}, M_{z2}, M_{z3}] \leq \frac{1}{k_z} \times \frac{C_{0,\text{guide}}}{f_s}$$

$F_{y/z,\text{stat}}$	Maximum value of the calculated force load per cycle phase
$M_{x/y/z,\text{stat}}$	Maximum value of the calculated torque load per cycle phase
$F_{y1/2/3}$	Calculated force load per cycle phase

$M_{x1/2/3}$ , $M_{y1/2/3}$ , $M_{z1/2/3}$	Calculated torque load per cycle phase
$C_{0,\text{guide}}$	Static basic load rating of ball screw → 11
$k_{x/y/z}$	Torque equivalence factors → 11
$f_s$	Safety factor against static overload $f_s = 1.0 \dots 3.0$

# Electric slides EGSK

Technical data

Dimensions

Download CAD data → [www.festo.com](http://www.festo.com)

EGSK-15

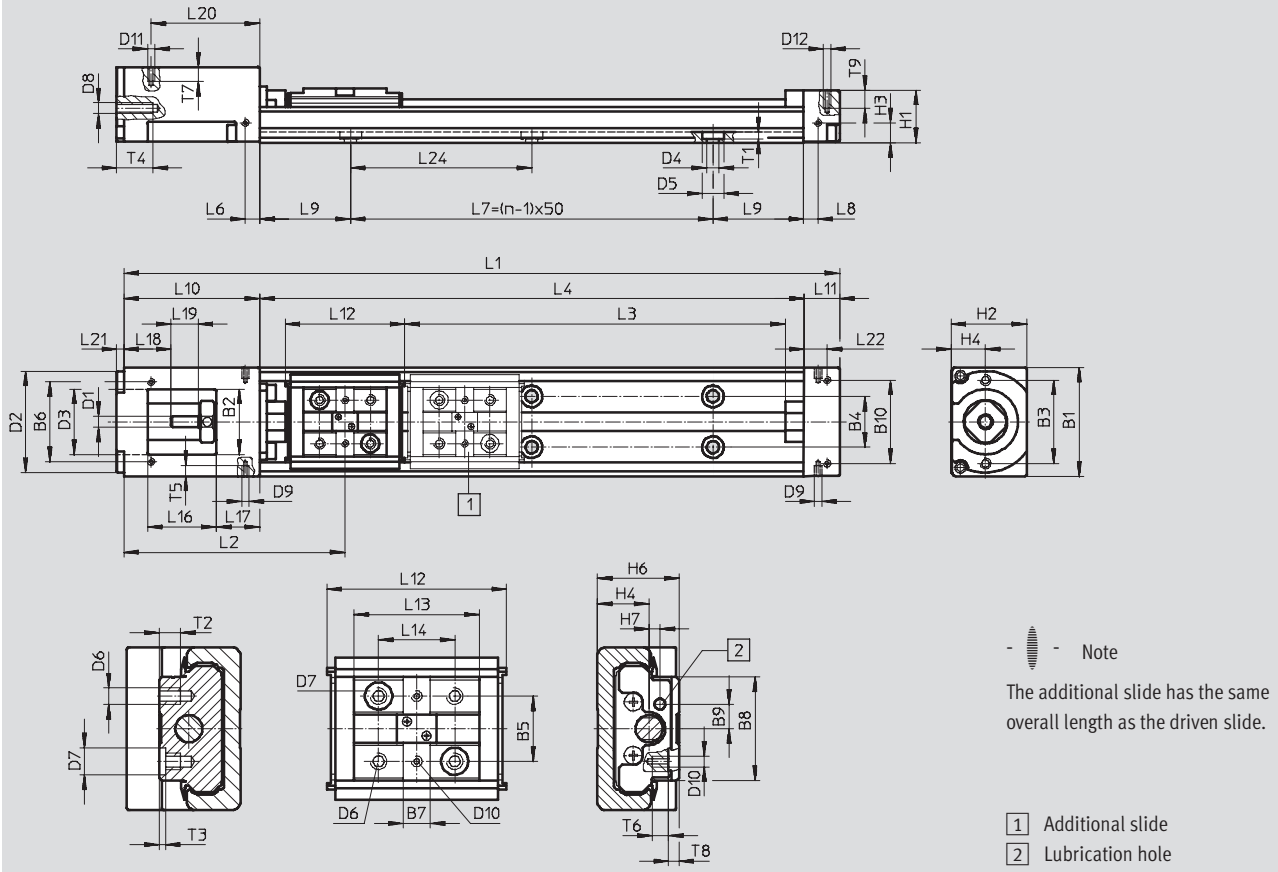

Size	Stroke	L1	L3 +4	L4	L7	L9	n
15	25	122.5	30	75	50	12.5	2
	50	147.5	55	100	50	25	2
	75	172.5	80	125	100	12.5	3
	100	197.5	105	150	100	25	3

Size	B1	B2	B3	B4	B5	B6	B7	B8	B9	B10	D1	D2	D3	D4	D5	D6	D7	D8
15	30	18	±0.1 23	14	±0.02 12	±0.1 22	5	19	4.5	±0.1 23	∅ h6 3	∅ g7 28	∅ 18	∅ 3.4	∅ 6	M3	∅ H7 5	M3

Size	D9	D10	D11	D12	H1	H2	H3	H4	H6	H7	L2	L6	L8	L10	L11	L12	L13	L14
15	M2	M2	M2	M2	14.5	20.9	5.5	9.5	15	2	60.3	4	4	37.5	10	33	23	±0.02 14

Size	L16	L17	L18	L19	L20	L21	L22	L24	T1	T2	T3	T4	T5	T6	T7	T8	T9
15	19	12	13	7.5	±0.1 30	2	±0.1 6.5	50	2	4	+0.1 1.2	10	3	3	4	1.9	5

# Electric slides EGSK

Technical data

**Dimensions**

Download CAD data → [www.festo.com](http://www.festo.com)

EGSK-20/26

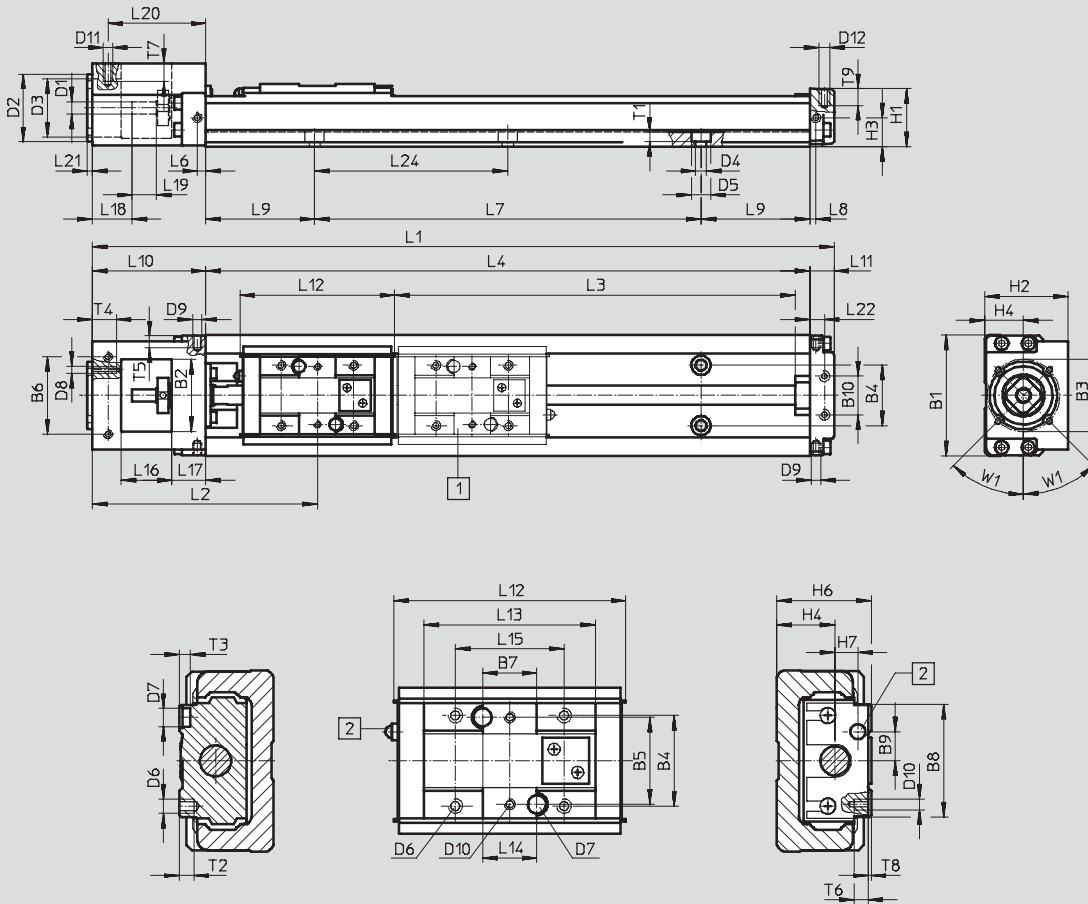

 Note

The additional slide has the same overall length as the driven slide.

- 1 Additional slide
- 2 Lubrication nipple

Size	Stroke	L1	L3 +4	L4	L7= (n-1)x60	L9	n
20	25	152	40	100	60	20	2
	75	202	90	150	120	15	3
	125	252	140	200	120	40	3

Size	Stroke	L1	L3 +4	L4	L7= (n-1)x80	L9	n
26	50	207	67	150	80	35	2
	100	257	117	200	160	20	3
	150	307	167	250	160	45	3
	200	357	217	300	240	30	4



# Electric slides EGSK

Technical data

**FESTO**

Size	B1	B2	B3 ∅	B4	B5 ±0.02	B6 ±0.1	B7	B8	B9	B10 ±0.1	D1 ∅ h7	D2 ∅ g7	D3 ∅	D4 ∅
20	40	22	30	18	18	29	10	23	5	18	4	28	22	3.4
26	50	30	30	25	24	32	15	31	8	16	5	28	24	4.5

Size	D5 ∅	D6	D7 ∅ H7	D8	D9	D10	D11	D12	H1	H2	H3	H4	H6	H7
20	6.5	M3	2	M3	M2.6	M2	M2.5	M2.5	19	28	10	13	20	3.4
26	8	M4	5	M3	M2.6	M3	M2.5	M3	24	34.5	12	16	26	6

Size	L2	L6	L8	L10	L11	L12	L13	L14 <sup>1)</sup> ±0.02	L15	L16	L17	L18	L19	L20 ±0.1
20	72.5	3.5	2.5	42	10	46	33.2	10	20	18	12	16	8	34.5
26	91	3.5	2.5	47	10	64	47.4	15	30	21	14	16.5	10	40.5

Size	L21	L22 ±0.1	L24	T1	T2	T3	T4	T5	T6	T7	T8	T9	W1
20	2	6.5	60	3	4.5	3	10	4	5	5	0.9	5	45°
26	2	6	80	4	6.5	3	10	4	6	5	0.9	6	45°

1) Distance between the locating holes

# Electric slides EGSK

Technical data

**Dimensions**

Download CAD data → [www.festo.com](http://www.festo.com)

EGSK-33/46

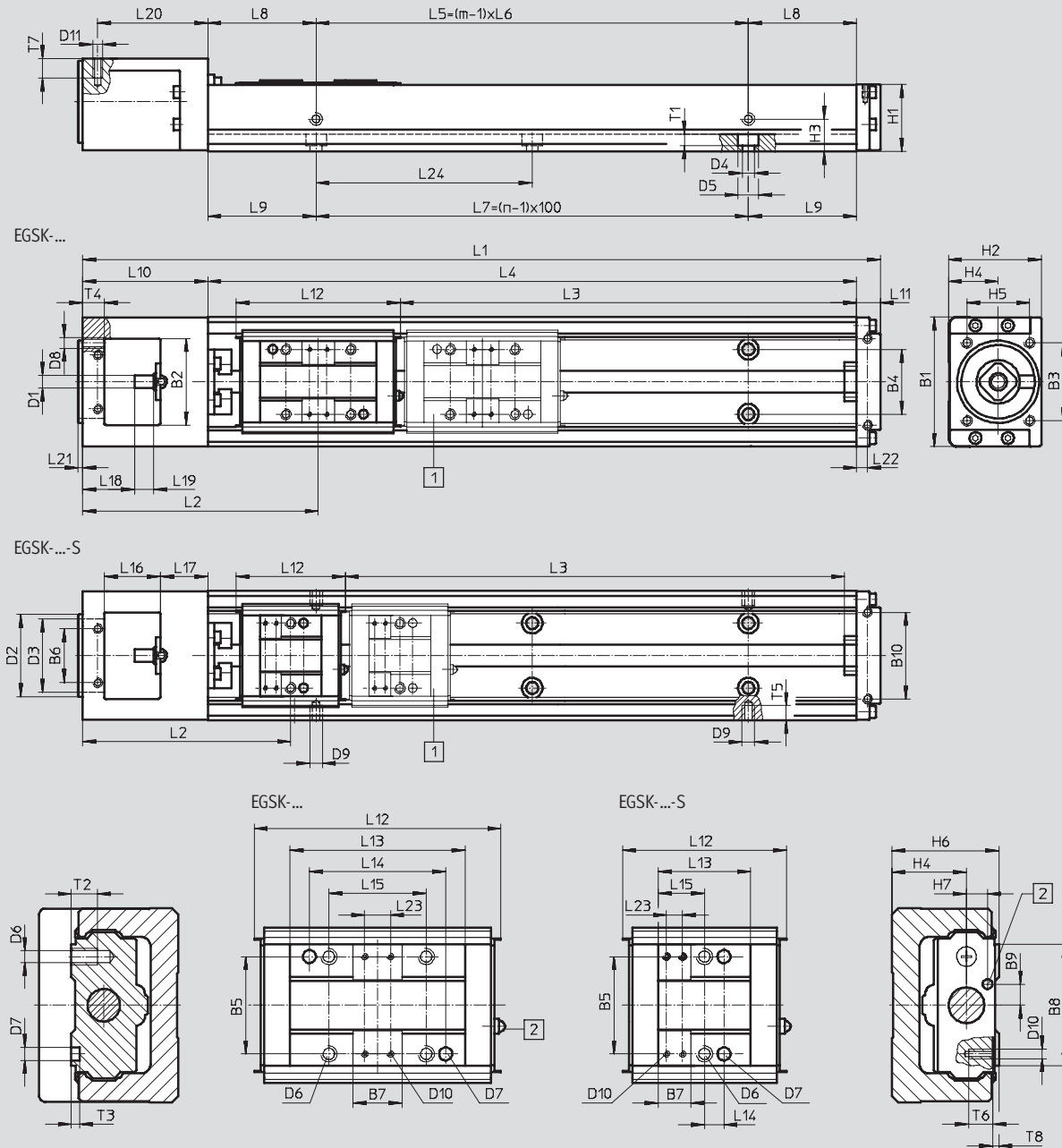

 Note

The additional slide has the same overall length as the driven slide.

- 1 Additional slide
- 2 Lubrication nipple

# Electric slides EGSK

Technical data

**FESTO**

Size	Stroke	L1	L3 +4		L4	L5	L6	L7	L8	m	n
				S							
33	100	269	110	135	200	100	100	100	50	2	2
	200	369	210	235	300	200	200	200	50	2	3
	300	469	310	335	400	200	200	300	100	2	4
	400	569	410	435	500	400	200	400	50	3	5
	500	669	510	535	600	400	200	500	100	3	6
	600	769	610	635	700	600	200	600	50	4	7

Size	Stroke	L1	L3 +4		L4	L5	L6	L7	L8	m	n
				S							
46	200	425.5	206	244	340	200	200	200	70	2	3
	300	525.5	306	344	440	400	200	300	20	3	4
	400	625.5	406	444	540	400	200	400	70	3	5
	500	725.5	506	544	640	600	200	500	20	4	6
	600	825.5	606	644	740	600	200	600	70	4	7
	800	1,025.5	806	844	940	800	200	800	70	5	9

Size	B1	B2	B3 ±0.1	B4	B5 ±0.04	B6 ±0.1	B7	B8	B9	B10 ±0.1	D1 ∅ h7	D2 ∅ g7	D3 ∅	D4 ∅	D5 ∅
33	60	40	36	30	30	25	15	37.4	6.5	40	6	38	34	5.5	9.5
46	86	48	36	46	46	42	15	54.4	10	58	8	38	34	6.6	11

Size	D6	D7 ∅ H7	D8	D9	D10	D11	H1	H2	H3	H4	H5 ±0.1	H6	H7	L2	
															S
33	M5	4	M5	M2.6	M2	M3	31	43	15	23	29	33	6.5	105	92.3
46	M6	5	M5	M2.6	M2	M4	43.5	60	28	32	29	46	9	142.5	123.8

Size	L9	L10	L11	L12		L13		L14		L15		L16	L17	L18	L19
					S		S	±0.04	S ±0.1		S				
33	50	58	11	76	50.5	54	28.5	42	6	30	14.25	26	22	24	9
46	70	72.5	13	110	72.5	81	43.5	28	11	46	21.75	33.5	25	21.5	18

Size	L20 ±0.1	L21	L22 ±0.1	L23		L24	T1	T2	T3	T4	T5	T6	T7	T8
					S									
33	51	2	5	8	5	100	5.4	8	2.5	10	4	5	6	1
46	65.5	2	3.5	8	8	100	6.5	12	2.5	10	4	5	8	1

## Electric slides EGSK

Technical data

Ordering data – Electric slides with standard slide					
Size	Stroke [mm]	Part No.	Type	Part No.	Type
		Spindle pitch 1 mm		Spindle pitch 6 mm	
20	25	562758	EGSK-20-25-1P	562761	EGSK-20-25-6P
	75	562759	EGSK-20-75-1P	562762	EGSK-20-75-6P
	125	562760	EGSK-20-125-1P	562763	EGSK-20-125-6P

Size	Stroke [mm]	Part No.	Type	Part No.	Type
		Spindle pitch 2 mm		Spindle pitch 6 mm	
26	50	562764	EGSK-26-50-2P	562768	EGSK-26-50-6P
	100	562765	EGSK-26-100-2P	562769	EGSK-26-100-6P
	150	562766	EGSK-26-150-2P	562770	EGSK-26-150-6P
	200	562767	EGSK-26-200-2P	562771	EGSK-26-200-6P

Size	Stroke [mm]	Part No.	Type	Part No.	Type
		Spindle pitch 6 mm		Spindle pitch 10 mm	
33	100	562772	EGSK-33-100-6P	562778	EGSK-33-100-10P
	200	562773	EGSK-33-200-6P	562779	EGSK-33-200-10P
	300	562774	EGSK-33-300-6P	562780	EGSK-33-300-10P
	400	562775	EGSK-33-400-6P	562781	EGSK-33-400-10P
	500	562776	EGSK-33-500-6P	562782	EGSK-33-500-10P
	600	562777	EGSK-33-600-6P	562783	EGSK-33-600-10P

Size	Stroke [mm]	Part No.	Type	Part No.	Type
		Spindle pitch 10 mm		Spindle pitch 20 mm	
46	200	562784	EGSK-46-200-10P	562790	EGSK-46-200-20P
	300	562785	EGSK-46-300-10P	562791	EGSK-46-300-20P
	400	562786	EGSK-46-400-10P	562792	EGSK-46-400-20P
	500	562787	EGSK-46-500-10P	562793	EGSK-46-500-20P
	600	562788	EGSK-46-600-10P	562794	EGSK-46-600-20P
	800	562789	EGSK-46-800-10P	562795	EGSK-46-800-20P

# Electric slides EGSK

Ordering data – Modular products

Ordering table										
Size	15	20	26	33	46	Condi- tions	Code	Enter code		
<b>M</b> Module No.	<b>562749</b>	<b>562750</b>	<b>562751</b>	<b>562752</b>	<b>562753</b>					
Drive function	Electric slide drive							<b>EGSK</b>	EGSK	
Size	15	20	26	33	46		-...	-...		
Standard stroke for standard slide [mm]	25	-		-			-25	-...		
	50	-	50	-	-		-50	-...		
	75	-		-			-75	-...		
	100	-	100	-	-		-100	-...		
	-	125	-		-		-125	-...		
	-	-		150	-	-		-150	-...	
	-	-		200	-		-200	-...		
	-	-			300	-		-300	-...	
	-	-			400	-		-400	-...	
	-	-			500	-		-500	-...	
	-	-			600	-		-600	-...	
	-	-				800	-		-800	-...
	Standard stroke for slide, short [mm]	-			130	-	-		-130	-...
-			230	-	-		-230	-...		
-				240	-		-240	-...		
-				330	-	-		-330	-...	
-				340	-		-340	-...		
-				430	-	-		-430	-...	
-				440	-		-440	-...		
-				530	-	-		-530	-...	
-				540	-		-540	-...		
-				630	-	-		-630	-...	
-				640	-		-640	-...		
Spindle pitch [mm]	1	-		-			-1P	-...		
	2	-	2	-	-		-2P	-...		
	-	6	-		-		-6P	-...		
	-	-	-	10	-		-10P	-...		
	-	-			20	-		-20P	-...	
<b>O</b> Accuracy	-		Standard accuracy				-	-...		
	Greater accuracy							-H	-...	
	Precision accuracy						[1]	-P	-...	
Slide design	Standard slide						-	-...		
	-			Slide, short			-S	-...		
Additional slide	No additional slide							-	-...	
	Additional slide (additional slide Z in combination with slide design S also results in a short slide)						[2]	-Z	-...	

- [1] **P** With size 33 not in combination with stroke for standard slide 600 and stroke for slide, short 630  
 With size 46 not in combination with stroke for standard slide 800 and stroke for slide, short 840
- [2] **Z** With size 15 not in combination with stroke for standard slide 25 and stroke for standard slide 50  
 With size 20 not in combination with stroke for standard slide 25  
 With size 26 not in combination with stroke for standard slide 50  
 With size 33 not in combination with stroke for standard slide 100

**Transfer order code**

	<b>EGSK</b>	-		-		-		-		-		-		-	
--	-------------	---	--	---	--	---	--	---	--	---	--	---	--	---	--

# Electric slides EGSP

Type codes

		EGSP	-	26	-	150	-	2P	-	H	-		-	Z
<b>Type</b>														
EGSP	Electric slide													
<b>Size</b>														
<b>Stroke [mm]</b>														
<b>Spindle pitch</b>														
<b>Accuracy</b>														
-	Standard													
H	High accuracy													
P	Precision design													
<b>Slide design</b>														
-	Standard slide													
S	Slide, short													
<b>Additional slide</b>														
-	No additional slide													
Z	Additional slide													

# Electric slides EGSP

Technical data

Function

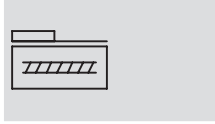

- Ø - Size  
20 ... 46
- | - Stroke length  
25 ... 840 mm



General technical data										
Size		20		26		33			46	
Spindle pitch		1	6	2	6	6	10	20	10	20
	Code <sup>1)</sup>									
Constructional design		Electromechanical linear axis with recirculating ball bearing spindle								
Guide		Recirculating ball bearing guide								
Installation position		Any								
Type of mounting for effective load		Female thread Locating pin								
Working stroke <sup>2)</sup>	- [mm]	25 ... 125		50 ... 200		100 ... 600			200 ... 800	
	S [mm]	-		-		130 ... 630			240 ... 840	
Max. feed force	-/H <sup>3)</sup> [N]	69	72	168	164	370	227	165	365	267
F <sub>x,max</sub>	P <sup>4)</sup> [N]	87	112	212	212	466	286	208	460	337
Max. driving torque	-/H <sup>3)</sup> [Ncm]	1.1	6.9	5.3	16	35	36	53	58	85
M <sub>Driving,max</sub>	P <sup>4)</sup> [Ncm]	1.4	11	6.7	20	45	46	66	73	107
No-load torque	-/H [Ncm]	0.5	0.5	1.5	1.5	7	7	7	10	10
M <sub>No-load</sub>	P [Ncm]	1.2	1.2	4.0	4.0	15	15	15	17	17
Max. rotational speed <sup>5)</sup>	[1/min]	6,000	6,000	6,000	6,000	6,000	6,000	6,000	6,000	6,000
Max. speed <sup>5)</sup>	-/H [m/s]	0.1	0.6	0.2	0.6	0.6	1	2	1	2
	P [m/s]	0.1	0.6	0.2	0.6	0.6	1	2	1	2
Max. acceleration	[m/s <sup>2</sup> ]	10		10		20			20	
Homing		Inductive proximity sensor SIES-8M								

1) Variant code → 22

2) Maximum travel distance → 31

In combination with an additional slide, the working stroke is reduced by the length of the additional slide and the distance between the two slides

 3) Loads are based on a service life specification of 5 x 10<sup>8</sup> rotations

 4) Loads are based on a service life specification of 2.5 x 10<sup>8</sup> rotations

5) Reduced speeds with sizes 33 and 46 with long strokes → 25

Operating and environmental conditions		
Ambient temperature	[°C]	0 ... +40
Relative air humidity	[%]	0 ... 95 (non-condensing)

Weight [kg]									
Size		20		26		33		46	
	Code <sup>1)</sup>								
Basic weight with 0 mm stroke <sup>2)</sup>	-	0.38		0.78		1.38		3.60	
	S	-		-		1.30		3.30	
Additional weight per 100 mm stroke	-	0.27		0.42		0.72		1.40	
Moving load	-	0.07		0.15		0.31		0.91	
	S	-		-		0.17		0.57	
Additional slide Z	-	0.07		0.15		0.31		0.91	
	S	-		-		0.17		0.57	

1) Variant code → 22

2) Including slide, without additional slide

# Electric slides EGSP

Technical data

Accuracy data [µm]				20		26		33		46	
Size	Stroke	Code <sup>1)</sup>									
Repetition accuracy <sup>2)</sup>		–	±10	±10	±10	±10	±10	±10	±10	±10	±10
		H	±5	±5	±5	±5	±5	±5	±5	±5	±5
		P	±3	±3	±3	±3	±3	±3	±3	±3	±3
Running parallelism	25 ... 340	H	25	25	25	25	25	25	25	25	35
	400 ... 540	H	–	–	–	–	–	–	–	–	35
	600 ... 640	H	–	–	–	–	–	–	–	–	40
	800 ... 840	H	–	–	–	–	–	–	–	–	50
	25 ... 340	P	10	10	10	10	10	10	10	10	15
	400 ... 540	P	–	–	–	–	–	–	–	–	15
	600 ... 640	P	–	–	–	–	–	–	–	–	20
Max. reversing play		–	20	20	20	20	20	20	20	20	20
		H	10	10	10	10	10	10	10	10	20
		P	3	3	3	3	3	3	3	3	3

1) Variant code → 22

2) The repetition accuracy that can be achieved with a motor/axis system is also influenced by the angle resolution of the motor and the chosen control parameters. The specified repetition accuracy cannot, therefore, be achieved with all motors.

## Materials

Sectional view

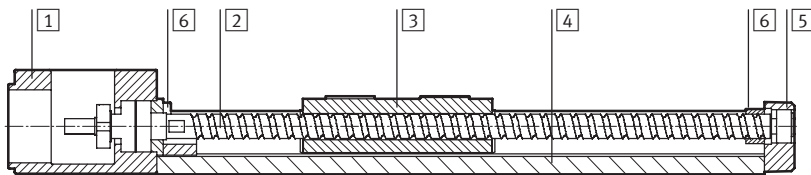

Electric slide		
1	Drive cover	Die-cast aluminium, coated
2	Spindle	Steel
3	Slide	Steel
4	Profile	High-alloy steel
5	End cap	Die-cast aluminium, coated
6	Buffer	Ethylene vinyl acetate copolymer
Note on materials		RoHS-compliant
		Contains PWIS (paint-wetting impairment substances)

Mass moment of inertia											
Size			20		26		33			46	
Spindle pitch	Code <sup>1)</sup>		1	6	2	6	6	10	20	10	20
J <sub>0</sub>		[kg mm <sup>2</sup> ]	0.087	0.143	0.355	0.479	2.72	3.22	5.57	8.51	15.42
	S	[kg mm <sup>2</sup> ]	–	–	–	–	1.93	2.21	–	6.10	10.43
J <sub>S</sub> per 100 mm stroke		[kg mm <sup>2</sup> /100 mm]	0.099		0.314		0.766			3.877	
J <sub>L</sub> per kg effective load		[kg mm <sup>2</sup> /kg]	0.03	0.91	0.10	0.91	0.91	2.53	10.13	2.53	10.13
J <sub>W</sub> per additional slide		[kg mm <sup>2</sup> ]	0.002	0.058	0.016	0.14	0.28	0.79	3.14	2.31	9.22
	S	[kg mm <sup>2</sup> ]	–	–	–	–	0.16	0.43	–	1.44	5.78

1) Variant code → 22

The mass moment of inertia J<sub>A</sub> of the entire axis is calculated as follows:

$$J_A = J_0 + J_W + J_S \times \text{working stroke} + J_L \times m_{\text{effective load}}$$



# Electric slides EGSP

Technical data

FESTO

## Speed v, rotational speed n as a function of working stroke l

EGSP-33-...-6P

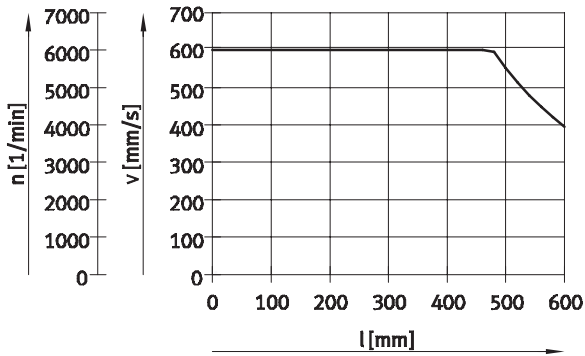

EGSP-33-...-10P

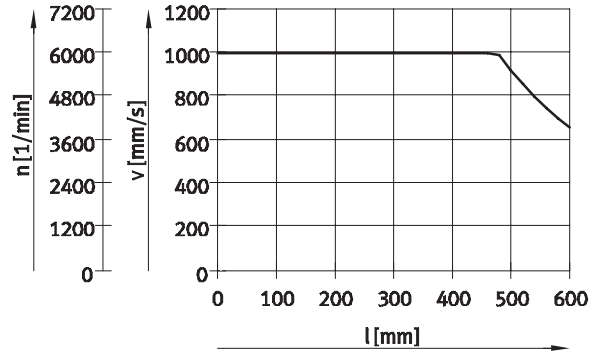

EGSP-33-...-20P

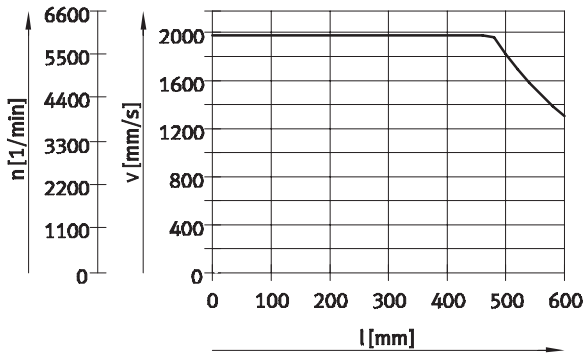

EGSP-46-...-10P

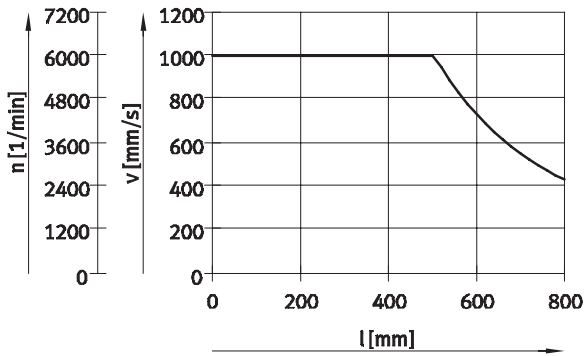

EGSP-46-...-20P

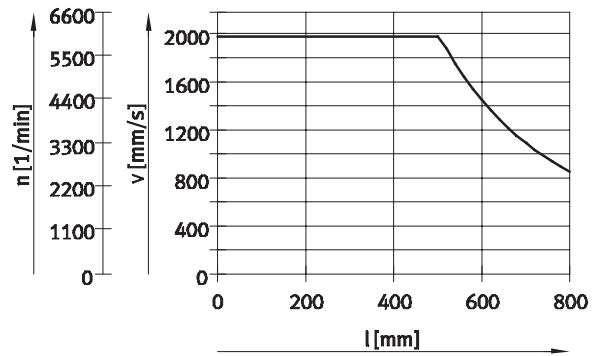

## 2nd moment of area

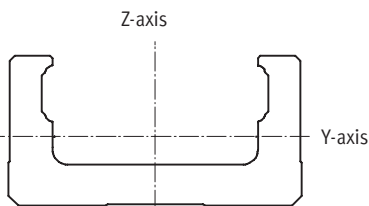

Size		20	26	33	46
ly	[mm <sup>4</sup> ]	6,000	16,600	53,500	205,000
lz	[mm <sup>4</sup> ]	61,400	148,000	352,000	1,450,000

# Electric slides EGSP

Technical data

## Characteristic load values

The indicated forces and torques refer to the centre axis of the spindle.  
The coordinate zero point is the point where the centre of the guide and the longitudinal centre of the slide intersect.

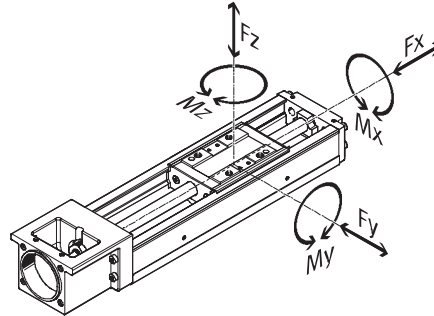

 Note  
PositioningDrives  
sizing software  
www.festo.com

Permissible forces and torques <sup>1)</sup>			20		26		33			46	
Size			1	6	2	6	6	10	20	10	20
Spindle pitch	Code <sup>2)</sup>										
F <sub>y</sub> max., F <sub>z</sub> max.	-/H <sup>3)</sup>	- [N]	2,325	1,279	3,991	2,767	3,619	3,052	2,422	7,092	5,629
	P <sup>4)</sup>	- [N]	2,929	1,612	5,028	3,486	4,559	3,845	3,052	8,935	7,092
	-/H <sup>3)</sup>	S [N]	-	-	-	-	2,405	2,029	-	5,099	4,047
	P <sup>4)</sup>	S [N]	-	-	-	-	3,031	2,556	-	6,424	5,099
M <sub>x</sub> max.	-/H <sup>3)</sup>	- [Nm]	28.8	15.9	64.7	44.8	71.7	60.4	48.0	205	163
	P <sup>4)</sup>	- [Nm]	36.3	20.0	81.5	56.5	90.3	76.1	60.4	258	205
	-/H <sup>3)</sup>	S [Nm]	-	-	-	-	47.6	40.2	-	147	117
	P <sup>4)</sup>	S [Nm]	-	-	-	-	60.0	50.6	-	186	147
M <sub>y</sub> max., M <sub>z</sub> max.	-/H <sup>3)</sup>	- [Nm]	9.9	5.5	25.1	17.4	25.5	21.5	17.1	74.6	59.2
	P <sup>4)</sup>	- [Nm]	12.5	6.9	31.6	21.9	32.1	27.1	21.5	94.0	74.6
	-/H <sup>3)</sup>	S [Nm]	-	-	-	-	10.1	8.5	-	34.9	27.7
	P <sup>4)</sup>	S [Nm]	-	-	-	-	12.7	10.7	-	44.0	34.9

- 1) Calculated with a speed-dependent load factor  $f_w$  of 1.2
- 2) Variant code → 22
- 3) Loads are based on a service life specification of  $5 \times 10^8$  rotations and a load factor  $f_w$  of 1.2
- 4) Loads are based on a service life specification of  $2.5 \times 10^8$  rotations and a load factor  $f_w$  of 1.2

Basic load ratings			20		26		33			46	
Size			1	6	2	6	6	10	20	10	20
Spindle pitch	Code <sup>1)</sup>										
Ball screw											
Static C <sub>0</sub> ball screw	-/H	[N]	1,170	1,450	4,020	3,510	6,290	3,780	3,770	6,990	7,040
	P	[N]	1,170	1,600	4,020	3,900	6,290	3,780	3,770	6,990	7,040
Dynamic c <sub>dyn</sub> ball screw	-/H <sup>2)</sup>	[N]	660	860	2,350	1,950	4,400	2,700	2,620	4,350	4,240
	P <sup>2)</sup>	[N]	660	1,060	2,350	2,390	4,400	2,700	2,620	4,350	4,240
Fixed bearing											
Static C <sub>0</sub> bearing		[N]	735		1,230		2,700			3,330	
Dynamic c <sub>dyn</sub> bearing <sup>2)</sup>		[N]	1,150		2,000		6,250			6,700	

- 1) Variant code → 22
- 2) Dynamic basic load ratings are based on a basic service life of  $10^6$  rotations

# Electric slides EGSP

Technical data

**FESTO**

Basic load ratings											
Size		20		26		33		46			
Spindle pitch		1	6	2	6	6	10	20	10	20	
		Code <sup>1)</sup>									
Linear guide											
Static $C_{0,guide}$	-	[N]	8,030	16,500	20,400	45,900					
	S	[N]	-	-	11,500	-	28,700				
Dynamic $C_{dyn,guide}$ <sup>2)</sup>	-	[N]	4,770	10,318	13,493	31,351					
	S	[N]	-	-	8,969	-	22,541				
Torque equivalence factors											
$k_x$	-	[1/m]	80.7	61.7	50.5	34.6					
	S	[1/m]	-	-	50.5	-	34.6				
$k_y, k_z$	-	[1/m]	234.4	159.1	142	95.1					
	S	[1/m]	-	-	239.1	-	146.1				

1) Variant code → 22

2) Dynamic basic load ratings are based on a basic service life of 100 km

## Speed-dependent load factor $f_w$

$f_w = 1.0 \dots 1.2$  ( $v \leq 0.25$  m/s)

$f_w = 1.2 \dots 1.5$  ( $0.25$  m/s  $\leq v \leq 1.0$  m/s)

$f_w = 1.5 \dots 2.0$  ( $1.0$  m/s  $\leq v \leq 2.0$  m/s)

$f_w = 2.0 \dots 3.5$  ( $v \geq 2.0$  m/s)

## Calculation of the maximum feed force $F_x$

$$F_{x,max} = \frac{1}{f_w} \times \frac{\text{Min}[C_{dyn,KGT}; C_{dyn,bearing}]}{\sqrt[3]{\frac{L_{ref,rot}}{10^6}}}$$

## Calculation of the maximum forces $F_{y/z}$ and torques $M_{x/y/z}$

$$F_{y/z,max} = \frac{1}{f_w} \times \frac{C_{dyn,guide}}{\sqrt[3]{\frac{L_{ref,km}}{100km}}}$$

$$M_{x/y/z,max} = \frac{1}{k_{x/y/z}} \times \frac{1}{f_w} \times \frac{C_{dyn,guide}}{\sqrt[3]{\frac{L_{ref,km}}{100km}}}$$

# Electric slides EGSP

Technical data

## Calculation of the service life

Size	20		26		33			46		
Spindle pitch P	1	6	2	6	6	10	20	10	20	
	Code <sup>1)</sup>									
Reference service life	-/H	5 x 10 <sup>8</sup>								
in rotations, L <sub>ref,rot</sub>	P	2.5 x 10 <sup>8</sup>								
Reference service life	-/H [km]	500	3,000	1,000	3,000	3,000	5,000	10,000	5,000	10,000
in kilometres, L <sub>ref,km</sub>	P [km]	250	1,500	500	1,500	1,500	2,500	5,000	2,500	5,000

1) Variant code → 22

## 1 Representation of the loads

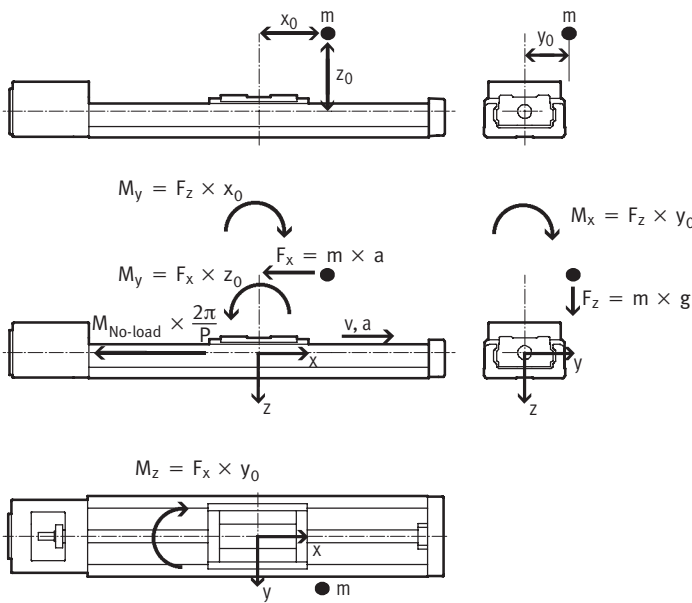

## 2 Determination of the loads over the travel cycle

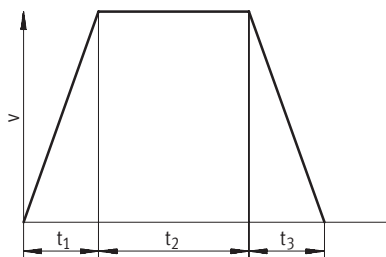

$$q_1 = \frac{t_1}{t_{tot}} \quad q_2 = \frac{t_2}{t_{tot}} \quad q_3 = \frac{t_3}{t_{tot}}$$

$$t_{tot} = t_1 + t_2 + t_3$$

v	Speed
t <sub>1</sub>	Acceleration time
t <sub>2</sub>	Constant travel time
t <sub>3</sub>	Deceleration time
q <sub>1/2/3</sub>	Relative time of the cycle phases
t <sub>tot</sub>	Cycle time

## Ball screw

For t<sub>1</sub>:  $F_{x1} = - (m \times a) - (M_{No-load} \times \frac{2\pi}{P})$

For t<sub>2</sub>:  $F_{x2} = - (M_{No-load} \times \frac{2\pi}{P})$

For t<sub>3</sub>:  $F_{x3} = m \times a - (M_{No-load} \times \frac{2\pi}{P})$

$$F_{x,dyn} = \sqrt[3]{q_1 \times |F_{x1}|^3 + q_2 \times |F_{x2}|^3 + q_3 \times |F_{x3}|^3}$$

F <sub>x1/2/3</sub>	Calculated force load per cycle phase
F <sub>x,dyn</sub>	Calculated average force load
m	Effective load (centre of gravity)
a	Acceleration
M <sub>No-load</sub>	No-load torque → 23
P	Spindle pitch → 23
q <sub>1/2/3</sub>	Relative time of the cycle phases

# Electric slides EGSP

Technical data

## 2 Determination of the loads over the travel cycle

### Linear guide

**For t<sub>1</sub>: a →, v →**

$$F_{y1} = 0$$

$$F_{z1} = m \times g$$

$$M_{x1} = F_z \times y_0 = m \times g \times y_0$$

$$M_{y1} = -F_z \times x_0 + F_x \times z_0 = -m \times g \times x_0 + m \times a \times z_0$$

$$M_{z1} = F_x \times y_0 = m \times a \times y_0$$

**For t<sub>2</sub>: a = 0, v →**

$$F_{y2} = 0$$

$$F_{z2} = m \times g$$

$$M_{x2} = F_z \times y_0 = m \times g \times y_0$$

$$M_{y2} = -F_z \times x_0 = -m \times g \times x_0$$

$$M_{z2} = 0$$

**For t<sub>3</sub>: a ←, v →**

$$F_{y3} = 0$$

$$F_{z3} = m \times g$$

$$M_{x3} = F_z \times y_0 = m \times g \times y_0$$

$$M_{y3} = -F_z \times x_0 - F_x \times z_0 = -m \times g \times x_0 - m \times a \times z_0$$

$$M_{z3} = -F_x \times y_0 = -m \times a \times y_0$$

$$F_{y,dyn} = \sqrt[3]{q_1 \times |F_{y1}|^3 + q_2 \times |F_{y2}|^3 + q_3 \times |F_{y3}|^3}$$

$$F_{z,dyn} = \sqrt[3]{q_1 \times |F_{z1}|^3 + q_2 \times |F_{z2}|^3 + q_3 \times |F_{z3}|^3}$$

$$M_{x,dyn} = \sqrt[3]{q_1 \times |M_{x1}|^3 + q_2 \times |M_{x2}|^3 + q_3 \times |M_{x3}|^3}$$

$$M_{y,dyn} = \sqrt[3]{q_1 \times |M_{y1}|^3 + q_2 \times |M_{y2}|^3 + q_3 \times |M_{y3}|^3}$$

$$M_{z,dyn} = \sqrt[3]{q_1 \times |M_{z1}|^3 + q_2 \times |M_{z2}|^3 + q_3 \times |M_{z3}|^3}$$

## 3 Total load

### Ball screw

$$\frac{|F_{x,dyn}|}{F_{x,max}} \leq f_v$$

$F_{x,dyn}$	Calculated average force load
$F_{x,max}$	Max. permissible force load → 23
$f_v$	Load comparison factor → 30

### Linear guide

$$\frac{|F_{y,dyn}|}{F_{y,max}} + \frac{|F_{z,dyn}|}{F_{z,max}} + \frac{|M_{x,dyn}|}{M_{x,max}} + \frac{|M_{y,dyn}|}{M_{y,max}} + \frac{|M_{z,dyn}|}{M_{z,max}} \leq f_v$$

$F_{y/z,dyn}$	Calculated average force load
$F_{y/z,max}$	Max. permissible force load → 26
$M_{x/y/z,dyn}$	Calculated average torque load
$M_{x/y/z,max}$	Max. permissible torque load → 26
$f_v$	Load comparison factor → 30

# Electric slides EGSP

Technical data

## 4 Determination of the load comparison factor $f_v$

$$f_v = \frac{1}{\sqrt[3]{q}} \quad \text{with} \quad q = \frac{L_{\text{calc,km}}}{L_{\text{ref,km}}} = \frac{L_{\text{calc,rot}}}{L_{\text{ref,rot}}}$$

for  $q = 1$ :

Calculated service life (here desired service life)  $L_{\text{calc,km}} = 1 \times$  reference service life  $L_{\text{ref,km}}$  gives  $f_v = 1$

for  $q \neq 1$ :

Calculated service life (here desired service life)  $L_{\text{calc,km}} = q \times$  reference service life  $L_{\text{ref,km}}$  read off ( $\rightarrow$  graph) or calculate  $f_v$

$f_v$	Load comparison factor
$q$	Quotient of desired service life divided by reference service life
$L_{\text{calc, km}}$	Calculated service life in km
$L_{\text{ref, km}}$	Reference service life in km $\rightarrow 28$
$L_{\text{calc, rot}}$	Calculated service life in rotations
$L_{\text{ref, rot}}$	Reference service life in rotations $\rightarrow 28$

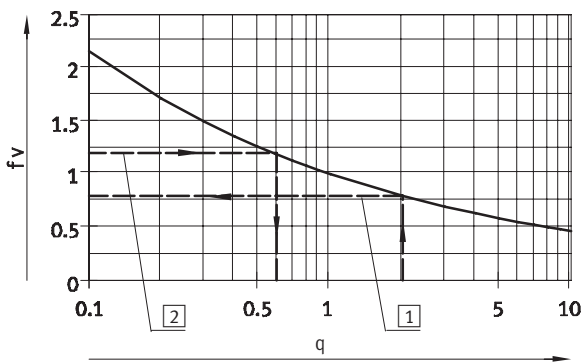

- 1  $\rightarrow$  Example 1
- 2  $\rightarrow$  Example 2

## 5 Calculation examples

Example 1:

EGSP-26-...-2P-H-...

$L_{\text{ref,km}} = 1,000 \text{ km}$

$L_{\text{calc,km}} = 2,000 \text{ km}$

$$q = \frac{2000\text{km}}{1000\text{km}} = 2.0$$

$$f_v = \frac{1}{\sqrt[3]{q}} = 0.79$$

Result:

A desired service life of 200% of the reference service life means that the permissible total load must be 21% lower.

Example 2:

If the total load calculation gives a load comparison factor  $f_v$  of 1.2, the mathematical service life is only approx. 60% ( $x = 0.6 \rightarrow$  graph) of the reference service life.

$$q = \frac{1}{f_v^3} = 0.58$$

## 6 Static sizing

Ball screw

$$F_{x,\text{stat}} = \text{Max}[F_{x1}, F_{x2}, F_{x3}] \leq \frac{C_{0,\text{KGT}}}{f_s}$$

$F_{x,\text{stat}}$	Maximum value of the calculated force load per cycle phase
$F_{x1/2/3}$	Calculated force load per cycle phase

$C_{0,\text{KGT}}$	Static basic load rating of ball screw $\rightarrow 26$
$f_s$	Safety factor against static overload $f_s = 1.0 \dots 3.0$

### Linear guide

$$F_{y,\text{stat}} = \text{Max}[F_{y1}, F_{y2}, F_{y3}] \leq \frac{C_{0,\text{guide}}}{f_s}$$

$$F_{z,\text{stat}} = \text{Max}[F_{z1}, F_{z2}, F_{z3}] \leq \frac{C_{0,\text{guide}}}{f_s}$$

$$M_{x,\text{stat}} = \text{Max}[M_{x1}, M_{x2}, M_{x3}] \leq \frac{1}{k_x} \times \frac{C_{0,\text{guide}}}{f_s}$$

$$M_{y,\text{stat}} = \text{Max}[M_{y1}, M_{y2}, M_{y3}] \leq \frac{1}{k_y} \times \frac{C_{0,\text{guide}}}{f_s}$$

$$M_{z,\text{stat}} = \text{Max}[M_{z1}, M_{z2}, M_{z3}] \leq \frac{1}{k_z} \times \frac{C_{0,\text{guide}}}{f_s}$$

$F_{y/z,\text{stat}}$	Maximum value of the calculated force load per cycle phase
$M_{x/y/z,\text{stat}}$	Maximum value of the calculated torque load per cycle phase
$F_{y1/2/3}$ , $F_{z1/2/3}$	Calculated force load per cycle phase

$M_{x1/2/3}$ , $M_{y1/2/3}$ , $M_{z1/2/3}$	Calculated torque load per cycle phase
$C_{0,\text{guide}}$	Static basic load rating of ball screw $\rightarrow 27$
$k_{x/y/z}$	Torque equivalence factors $\rightarrow 27$
$f_s$	Safety factor against static overload $f_s = 1.0 \dots 3.0$

# Electric slides EGSP

Technical data

Dimensions Download CAD data → [www.festo.com](http://www.festo.com)  
 EGSP-20/26

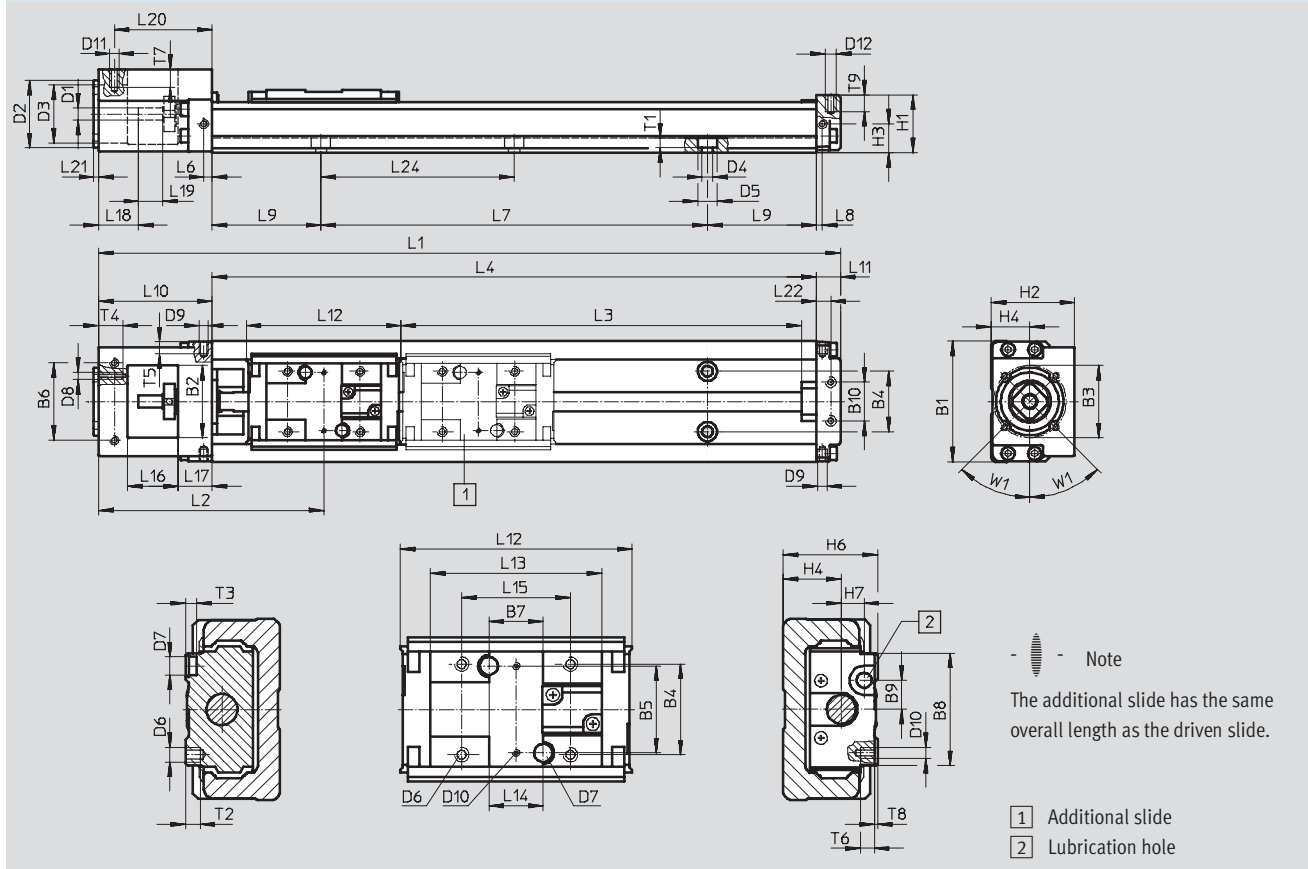

Size	Stroke	L1	L3 +4	L4	L7=(n-1)x60	L9	n	Size	Stroke	L1	L3 +4	L4	L7=(n-1)x80	L9	n
20	25	152	39	100	60	20	2	26	50	207	67	150	80	35	2
	75	202	89	150	120	15	3		100	257	117	200	160	20	3
	125	252	139	200	120	40	3		150	307	167	250	160	45	3
									200	357	217	300	240	30	4

Size	B1	B2	B3 ∅	B4	B5 ±0.02	B6 ±0.1	B7	B8	B9	B10 ±0.1	D1 ∅ h7	D2 ∅ g7	D3 ∅	D4 ∅	D5 ∅	D6	D7 ∅ H7	D8
20	40	22	30	18	18	29	10	23	5.5	18	4	28	22	3.4	6.5	M3	2	M3
26	50	30	30	25	24	32	15	31	8	16	5	28	24	4.5	8	M4	5	M3

Size	D9	D10	D11	D12	H1	H2	H3	H4	H6	H7	L2	L6	L8	L10	L11	L12	L13	L14 <sup>1)</sup> ±0.02
20	M2.6	M1.6	M2.5	M2.5	19	28	10	13	20	4	72.8	3.5	2.5	42	10	46	33.2	10
26	M2.6	M2	M2.5	M3	24	34.5	12	16	26	6.3	91.3	3.5	2.5	47	10	64	47.4	15

Size	L15	L16	L17	L18	L19 ±0.1	L20 ±0.1	L21	L22	L24	T1	T2	T3	T4	T5	T6	T7	T8	T9	W1
20	20	18	12	16	8	34.5	2	6.5	60	3	3	3	10	4	2.4	5	0.9	5	45°
26	30	21	14	16.5	10	40.5	2	6	80	4	4	3	10	4	3	5	0.9	6	45°

1) Distance between the locating holes

# Electric slides EGSP

Technical data

**Dimensions**

Download CAD data → [www.festo.com](http://www.festo.com)

EGSP-33/46

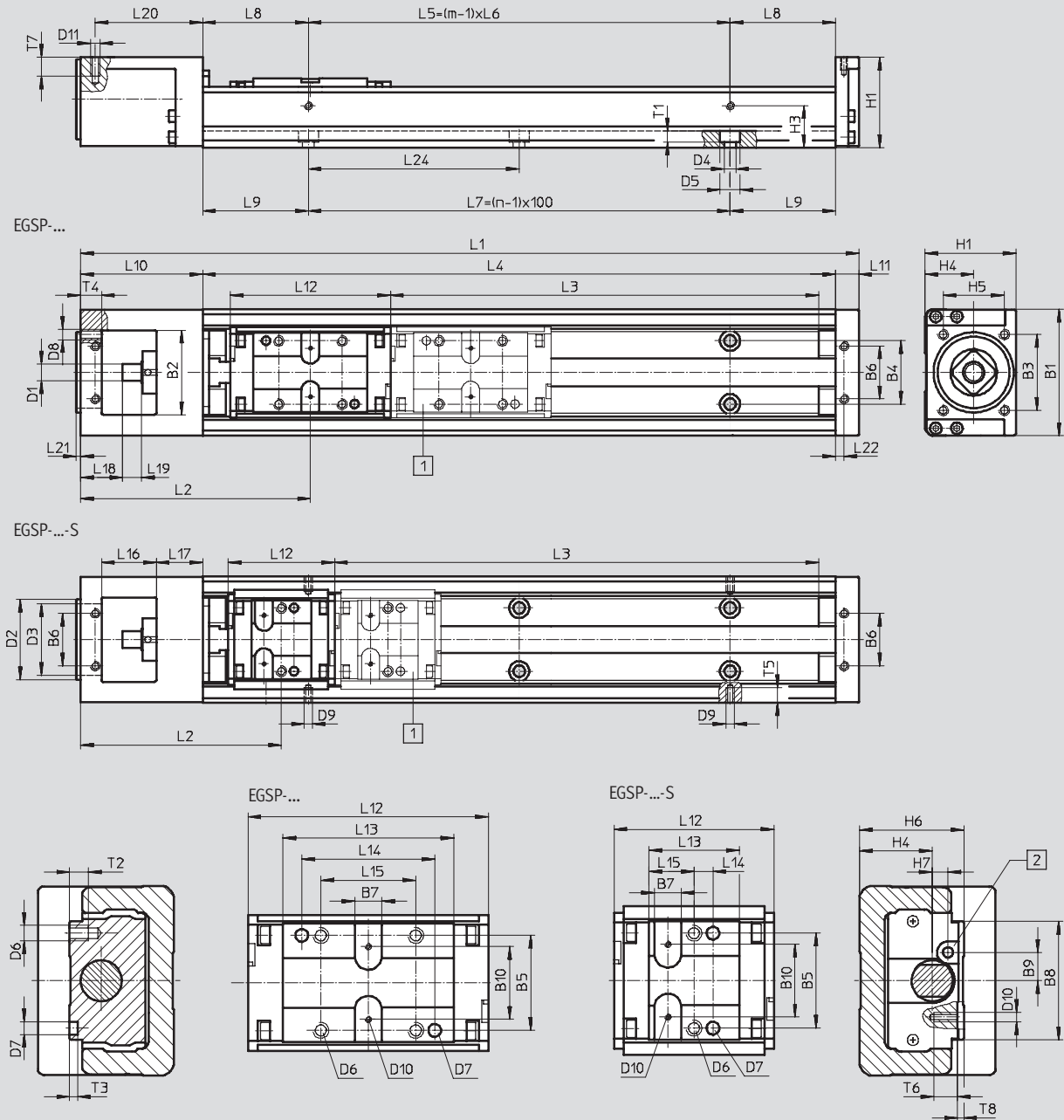

 **Note**

The additional slide has the same overall length as the driven slide.

- 1 Additional slide
- 2 Lubrication hole



# Electric slides EGSP

Technical data

**FESTO**

Size	Stroke	L1	L3 +4		L4	L5	L6	L7	L8	m	n
				S							
33	100	269	103	130	200	100	100	100	50	2	2
	200	369	203	230	300	200	200	200	50	2	3
	300	469	303	330	400	200	200	300	100	2	4
	400	569	403	430	500	400	200	400	50	3	5
	500	669	503	530	600	400	200	500	100	3	6
	600	769	603	630	700	600	200	600	50	4	7

Size	Stroke	L1	L3 +4		L4	L5	L6	L7	L8	m	n
				S							
46	200	425.5	206	240	340	200	200	200	70	2	3
	300	525.5	306	340	440	400	200	300	20	3	4
	400	625.5	406	440	540	400	200	400	70	3	5
	500	725.5	506	540	640	600	200	500	20	4	6
	600	825.5	606	640	740	600	200	600	70	4	7
	800	1,025.5	806	840	940	800	200	800	70	5	9

Size	B1	B2	B3 ±0.1	B4	B5 ±0.04	B6 ±0.1	B7	B8	B9	B10	D1 ∅ h7	D2 ∅ g7	D3 ∅	D4 ∅
33	60	40	36	30	30	25	8.5	37.4	8.9	23	8	38	34	5.5
46	86	48	36	46	46	42	10	54.4	10	46	10	38	34	6.6

Size	D5 ∅	D6	D7 ∅ H7	D8	D9	D10	D11	H1	H3	H4	H5 ±0.1	H6	H7	L2	
															S
33	9.5	M5	4	M5	M2.6	M2	M3	43	20	23	29	33	5	107	94.3
46	11	M6	5	M5	M2.6	M2	M4	60	29	32	29	46	8	140	123.5

Size	L9	L10	L11	L12		L13		L14		L15		L16	L17	L18	L19
					S		S	±0.04	±0.1		S				
33	50	58	11	76	50.5	54	28.5	42	6	30	14.25	26	22	20	9
46	70	72.5	13	110	77	81	48	28	11	46	24	33.5	25	19.5	18

Size	L20 ±0.1	L21	L22 ±0.1	L24	T1	T2	T3	T4	T5	T6	T7	T8
33	51	2	4	100	5.4	6	2.5	10	3.5	5	6	2
46	65.5	2	6	100	6.5	9	2.5	10	4	5	8	2

# Electric slides EGSP

Ordering data – Modular products

Ordering table							
Size	20	26	33	46	Condi- tions	Code	Enter code
<b>M</b> Module No.	<b>562754</b>	<b>562755</b>	<b>562756</b>	<b>562757</b>			
Drive function	Electric slide drive, with caged balls					<b>EGSP</b>	EGSP
Size	20	26	33	46		-...	-...
Standard stroke for standard slide [mm]	25	-	-	-		-25	-...
	-	50	-	-		-50	-...
	75	-	-	-		-75	-...
	-	100	-	-		-100	-...
	125	-	-	-		-125	-...
	-	150	-	-		-150	-...
	-	200	-	-		-200	-...
	-	-	300	-		-300	-...
	-	-	400	-		-400	-...
	-	-	500	-		-500	-...
	-	-	600	-		-600	-...
	-	-	-	800		-800	-...
	Standard stroke for slide, short [mm]	-	-	130	-		-130
-		-	230	-		-230	-...
-		-	-	240		-240	-...
-		-	330	-		-330	-...
-		-	-	340		-340	-...
-		-	430	-		-430	-...
-		-	-	440		-440	-...
-		-	530	-		-530	-...
-		-	-	540		-540	-...
-		-	630	-		-630	-...
-		-	-	640		-640	-...
-		-	-	840		-840	-...
Spindle pitch [mm]		1	-	-	-		-1P
	-	2	-	-		-2P	-...
	6	-	-	-		-6P	-...
	-	-	10	-		-10P	-...
	20	-	20	-		-20P	-...
<b>O</b> Accuracy	Standard accuracy						
	Greater accuracy					-H	
	Precision accuracy				[1]	-P	
Slide design	Standard slide					-	
			Slide, short		[2]	-S	
Additional slide	No additional slide					-	
	Additional slide (additional slide Z in combination with slide design S also results in a short slide)				[3]	-Z	

- [1] **P** With size 46 not in combination with stroke for standard slide 800 and stroke for slide, short 840
- [2] **S** With size 33 not in combination with spindle pitch 20
- [3] **Z** With size 20 not in combination with stroke for standard slide 25  
With size 26 not in combination with stroke for standard slide 50  
With size 33 not in combination with stroke for standard slide 100

**Transfer order code**

**EGSP** -  -  -  -  -  -  -  -

## Electric slides EGSK/EGSP

Accessories

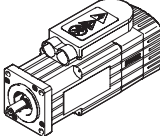
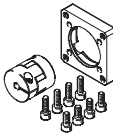
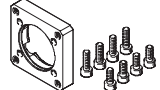
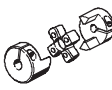
Permissible axis/motor combinations with axial kit – without gear unit			
Motor	Axial kit	Axial kit comprising:	
		Motor flange	Coupling
			
Type	Part No. Type	Part No. Type	Part No. Type
<b>EGSK-20/EGSP-20</b>			
With servo motor			
EMMS-AS-40-M-...	562637 EAMM-A-P4-28B-40A	552163 EAMF-A-28B-40A	562673 EAMC-16-20-4-6
With stepper motor			
EMMS-ST-42-S-...	562636 EAMM-A-P4-28B-42A	552164 EAMF-A-28B-42A	562674 EAMC-16-20-4-5
<b>EGSK-26/EGSP-26</b>			
With servo motor			
EMMS-AS-40-M-...	562641 EAMM-A-P5-28B-40A	552163 EAMF-A-28B-40A	543419 EAMC-16-20-5-6
With stepper motor			
EMMS-ST-42-S-...	562640 EAMM-A-P5-28B-42A	552164 EAMF-A-28B-42A	562676 EAMC-16-20-5-5
<b>EGSK-33</b>			
With servo motor			
EMMS-AS-40-M-...	562646 EAMM-A-P6-38A-40A	562667 EAMF-A-38A-40A	558312 EAMC-30-32-6-6
EMMS-AS-55-S-...	562647 EAMM-A-P6-38A-55A	558176 EAMF-A-38A-55A	551003 EAMC-30-32-6-9
With stepper motor			
EMMS-ST-42-S-...	562644 EAMM-A-P6-38A-42A	562668 EAMF-A-38A-42A	561333 EAMC-30-32-5-6
EMMS-ST-57-S-...	562645 EAMM-A-P6-38A-57A	560692 EAMF-A-38A-57A	551002 EAMC-30-32-6-6.35
<b>EGSK-46/EGSP-33</b>			
With servo motor			
EMMS-AS-40-M-...	562652 EAMM-A-P8-38A-40A	562667 EAMF-A-38A-40A	533708 EAMC-30-32-6-8
EMMS-AS-55-S-...	562653 EAMM-A-P8-38A-55A	558176 EAMF-A-38A-55A	543423 EAMC-30-32-8-9
EMMS-AS-70-S-...	564996 EAMM-A-P8-38A-70A	558018 EAMF-A-38A-70A	551004 EAMC-30-32-8-11
With stepper motor			
EMMS-ST-42-S-...	562650 EAMM-A-P8-38A-42A	562668 EAMF-A-38A-42A	562678 EAMC-30-32-5-8
EMMS-ST-57-S-...	562651 EAMM-A-P8-38A-57A	560692 EAMF-A-38A-57A	543421 EAMC-30-32-6.35-8
EMMS-ST-87-S-...	564998 EAMM-A-P8-38A-87A	560693 EAMF-A-38A-87A	551004 EAMC-30-32-8-11

## Electric slides EGSK/EGSP

Accessories

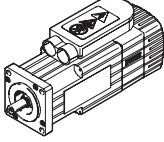
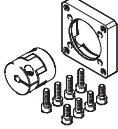
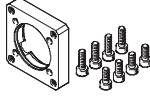
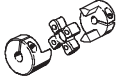
Permissible axis/motor combinations with axial kit – without gear unit			
Motor	Axial kit	Axial kit comprising:	
		Motor flange	Coupling
			
Type	Part No. Type	Part No. Type	Part No. Type
<b>EGSP-46</b>			
With servo motor			
<b>EMMS-AS-55-S-...</b>	562659 EAMM-A-P10-38A-55A	558176 EAMF-A-38A-55A	562680 EAMC-30-32-9-10
<b>EMMS-AS-70-S-...</b>	564997 EAMM-A-P10-38A-70A	558018 EAMF-A-38A-70A	565008 EAMC-30-32-10-11
With stepper motor			
<b>EMMS-ST-57-S-...</b>	562658 EAMM-A-P10-38A-57A	560692 EAMF-A-38A-57A	562679 EAMC-30-32-6.35-10
<b>EMMS-ST-87-S-...</b>	564999 EAMM-A-P10-38A-87A	560693 EAMF-A-38A-87A	565008 EAMC-30-32-10-11

# Electric slides EGSK/EGSP

Accessories



## Axial kit EAMM-A-...

Material:

Coupling hubs, motor flange:

Aluminium

Screws: Steel

RoHS-compliant

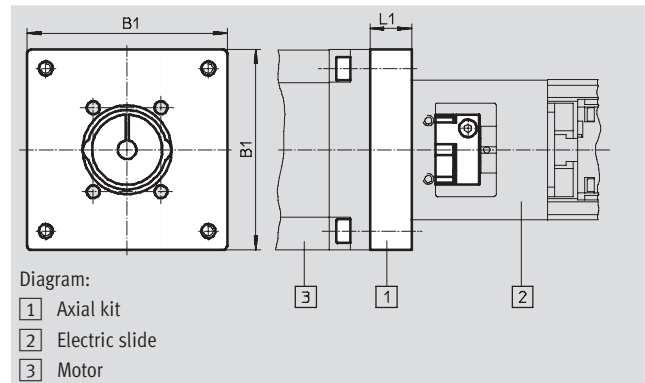

General technical data									
EAMM-A-...	P4-28B-		P5-28B-		P6-38A-				
	40A	42A	40A	42A	40A	42A	55A	57A	
Transferable torque	[Nm]	0.7	0.7	1.1	1.1	6.5	3.5	6.5	6.5
Mass moment of inertia	[kgmm <sup>2</sup> ]	0.28		5.88					
Max. rotational speed	[1/min]	10,000				8,000			
Installation position		Any							

EAMM-A-...	P8-38A-						P10-38A-				
	40A	42A	55A	57A	70A	87A	55A	57A	70A	87A	
Transferable torque	[Nm]	6.5	3.5	12.5	6.5	12.5	12.5	12.5	6.5	12.5	12.5
Mass moment of inertia	[kgmm <sup>2</sup> ]	5.88									
Max. rotational speed	[1/min]	8,000									
Installation position		Any									

Operating and environmental conditions		
Ambient temperature	[°C]	0 ... +50
Storage temperature	[°C]	-25 ... +60
Relative air humidity	[%]	0 ... 95 (non-condensing)

Dimensions and ordering data						
Type	B1	L1	Weight [g]	Part No.	Type	
EAMM-A-P4-28B-40A	40	8.3	50	562637	EAMM-A-P4-28B-40A	
EAMM-A-P5-28B-40A				562641	EAMM-A-P5-28B-40A	
EAMM-A-P4-28B-42A	42	16.5	60	562636	EAMM-A-P4-28B-42A	
EAMM-A-P5-28B-42A				562640	EAMM-A-P5-28B-42A	
EAMM-A-P6-38A-40A	50	9	100	562646	EAMM-A-P6-38A-40A	
EAMM-A-P8-38A-40A				562652	EAMM-A-P8-38A-40A	
EAMM-A-P6-38A-42A	55	15	160	562644	EAMM-A-P6-38A-42A	
EAMM-A-P8-38A-42A				562650	EAMM-A-P8-38A-42A	
EAMM-A-P6-38A-55A	55	11	130	562647	EAMM-A-P6-38A-55A	
EAMM-A-P8-38A-55A				562653	EAMM-A-P8-38A-55A	
EAMM-A-P10-38A-55A				562659	EAMM-A-P10-38A-55A	
EAMM-A-P6-38A-57A	56	11	130	562645	EAMM-A-P6-38A-57A	
EAMM-A-P8-38A-57A				562651	EAMM-A-P8-38A-57A	
EAMM-A-P10-38A-57A				562658	EAMM-A-P10-38A-57A	
EAMM-A-P8-38A-70A	70	13.75	200	564996	EAMM-A-P8-38A-70A	
EAMM-A-P10-38A-70A				564997	EAMM-A-P10-38A-70A	
EAMM-A-P8-38A-87A	85.8	18	380	564998	EAMM-A-P8-38A-87A	
EAMM-A-P10-38A-87A				564999	EAMM-A-P10-38A-87A	

# Electric slides EGSK/EGSP

Accessories

## Cross connecting kit EHAM

Material:

Adapter plate: Anodised aluminium

Screws, locating pins: Steel

RoHS-compliant

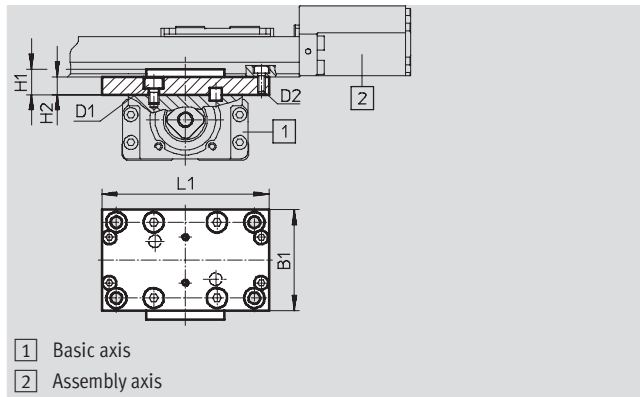

- 1 Basic axis
- 2 Assembly axis

Dimensions and ordering data										
For size		B1	D1	D2	H1	H2	L1	Weight	Part No.	Type
Basic axis	Assembly axis	±0.2					±0.2	[g]		
1	2									
20	15	30	M3	M3	7	5	56	27	563747	EHAM-S1-20-15
26	20	40	M4	M3	10	7	66	59	563748	EHAM-S1-26-20
33	26	54	M5	M4	12	9	86	124	563749	EHAM-S1-33-26
46	33	60	M6	M5	15	10	112	216	563750	EHAM-S1-46-33

# Electric slides EGSK/EGSP

Accessories

**FESTO**

## Slide adapter EASA

Material:  
 Adapter plate: Anodised aluminium  
 Screws, locating pins: Steel  
 RoHS-compliant

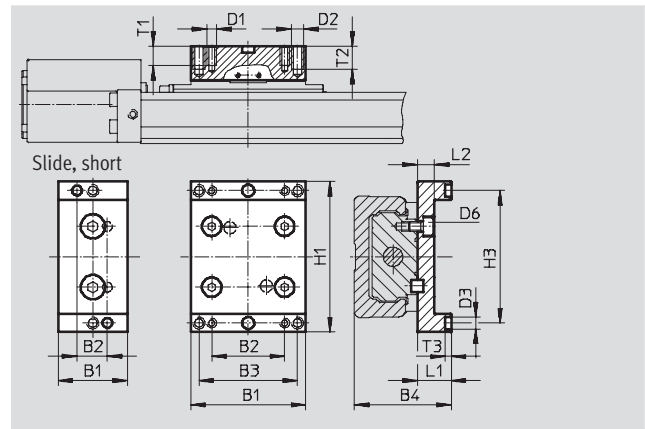

Dimensions and ordering data											
For size	B1	B2	B3	B4	D1	D2	D3	D6	H1	H3	
	±0.2						∅ H7		±0.2	±0.04	
With standard slide											
15	23	14	–	25	M3	–	4	M3	44	38	
20	33.2	23	–	32	M3	–	2	M3	52	44.5	
26	47.4	30	–	40	M4	–	5	M4	62	54.5	
33	54	40	–	48	M5	–	4	M5	86	74	
46	81	30	48	68	M5	M6	5	M6	112	100	
With slide, short											
33	28.5	12.5±0.04	–	48	M5	–	4	M5	86	74	
46	48	22±0.04	–	68	M6	–	5	M6	112	100	

For size	L1	L2	T1	T2	T3	Weight [g]	Part No.	Type
					±0.1			
With standard slide								
15	10	5.4	6	–	2.5	20	562742	EASA-S1-15
20	12	6	6	–	2.5	38	562743	EASA-S1-20
26	14	7	8	–	2.5	74	562744	EASA-S1-26
33	15	9	15	–	2.6	130	562745	EASA-S1-33
46	22	10	10	12	2.6	310	562746	EASA-S1-46
With slide, short								
33	15	9	15	–	2.6	70	562747	EASA-S1-33-S
46	22	10	12	–	2.6	180	562748	EASA-S1-46-S

# Electric slides EGSK/EGSP

Accessories

**Covering kit EASC**  
for standard slide

Material:  
Cover profile, adapter plate, adapter:  
Anodised aluminium  
Screws, locating pins: Steel  
RoHS-compliant

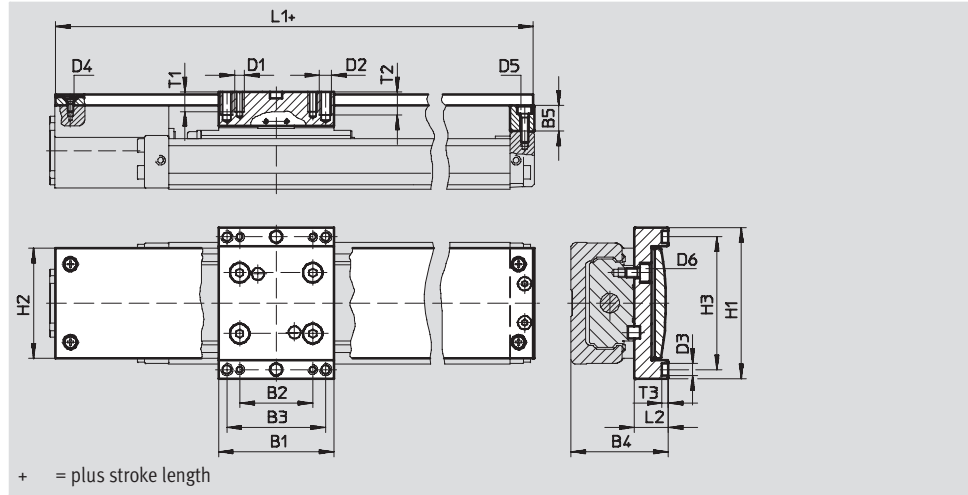

Dimensions										
For size	B1	B2	B3	B4	B5	D1	D2	D3 ∅ H7	D4	D5
15	±0.2	23	14	-	25	6.5	M3	-	4	M2
20	33.2	23	-	32	9	M3	-	2	M2.5	M2.5
26	47.4	30	-	40	10.5	M4	-	5	M2.5	M3
33	54	40	-	48	7	M5	-	4	M3	M3
46	81	30	48	68	10	M5	M6	5	M4	M4

For size	D6	H1	H2	H3	L1	L2	T1	T2	T3
		±0.2	±0.2	±0.04	-0.3				+0.1
15	M3	44	30	38	96.7	10	6	-	2.5
20	M3	52	35.6	44.5	126.2	12	6	-	2.5
26	M4	62	45	54.5	156.2	14	8	-	2.5
33	M5	86	62.5	74	168.2	15	15	-	2.6
46	M6	112	82.4	100	224.7	22	10	12	2.6

Ordering data										
For size	Stroke [mm]	Weight [g]	Part No.	Type	For size	Stroke [mm]	Weight [g]	Part No.	Type	
15	25	51	562707	EASC-S1-15-25	33	100	327	562718	EASC-S1-33-100	
	50	57	562708	EASC-S1-15-50		200	391	562719	EASC-S1-33-200	
	75	62	562709	EASC-S1-15-75		300	454	562720	EASC-S1-33-300	
	100	67	562710	EASC-S1-15-100		400	518	562721	EASC-S1-33-400	
20	25	92	562711	EASC-S1-20-25		500	581	562722	EASC-S1-33-500	
	75	107	562712	EASC-S1-20-75		600	645	562723	EASC-S1-33-600	
	125	121	562713	EASC-S1-20-125		46	200	850	562724	EASC-S1-46-200
26	50	187	562714	EASC-S1-26-50			300	965	562725	EASC-S1-46-300
	100	211	562715	EASC-S1-26-100			400	1,080	562726	EASC-S1-46-400
	150	234	562716	EASC-S1-26-150			500	1,200	562727	EASC-S1-46-500
	200	258	562717	EASC-S1-26-200			600	1,310	562728	EASC-S1-46-600
							800	1,540	562729	EASC-S1-46-800



# Electric slides EGSK/EGSP

Accessories

**Covering kit EASC**  
for slide, short

Material:  
Cover profile, adapter plate, adapter:  
Anodised aluminium  
Screws, locating pins: Steel  
RoHS-compliant

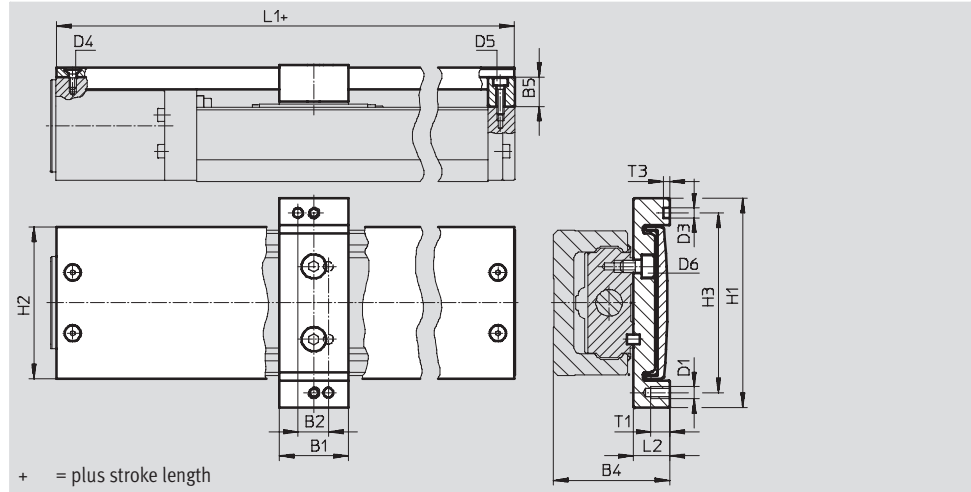

Dimensions								
For size	B1	B2	B4	B5	D1	D3	D4	D5
	±0.2	±0.04				∅ H7		
33	28.5	12.5	48	7	M5	4	M3	M3
46	48	22	68	10	M6	5	M4	M4

For size	D6	H1	H2	H3	L1	L2	T1	T3
		±0.2	±0.2	±0.04	-0.3			+0.1
33	M5	86	62.5	74	138.2	15	15	2.6
46	M6	112	82.4	100	184.7	22	12	2.6

Ordering data				
For size	Stroke [mm]	Weight [g]	Part No.	Type
33	130	263	562730	EASC-S1-33-130-S
	230	328	562731	EASC-S1-33-230-S
	330	391	562732	EASC-S1-33-330-S
	430	454	562733	EASC-S1-33-430-S
	530	518	562734	EASC-S1-33-530-S
	630	581	562735	EASC-S1-33-630-S
46	240	724	562736	EASC-S1-46-240-S
	340	840	562737	EASC-S1-46-340-S
	440	955	562738	EASC-S1-46-440-S
	540	1,070	562739	EASC-S1-46-540-S
	640	1,190	562740	EASC-S1-46-640-S
	840	1,420	562741	EASC-S1-46-840-S

# Electric slides EGSK/EGSP

Accessories

## Sensor strip EAPR

Material:  
 Sensor bracket: Anodised aluminium  
 Switching lug, screws:  
 Galvanised steel  
 RoHS-compliant

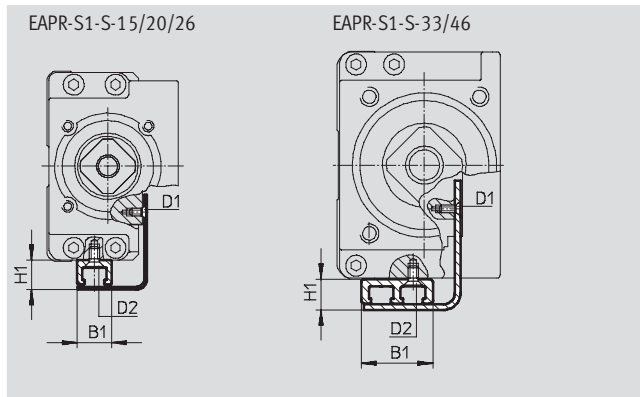

Dimensions						
For size	B1	H1		D1		D2
For type		EGSK	EGSP	EGSK	EGSP	
With standard slide						
15	9	8.5	-	M2	-	M2
20		7.75	7.75		M3	M1.6
26						M2
33	19	7.75	8.5	M2	M2	M2.5
46						
With slide, short						
33	19	7.5	8.5	M2	M2	M2.5
46		8.5				

Ordering data					
For size	Stroke	Weight	Part No.	Type	
For type	[mm]	[g]			
With standard slide					
15	25	10	562611	EAPR-S1-S-15-25	
	50	12	562612	EAPR-S1-S-15-50	
	75	14	562613	EAPR-S1-S-15-75	
	100	16	562614	EAPR-S1-S-15-100	
20	25	14	562615	EAPR-S1-S-20-25	
	75	18	562616	EAPR-S1-S-20-75	
	125	22	562617	EAPR-S1-S-20-125	
26	50	24	562618	EAPR-S1-S-26-50	
	100	28	562619	EAPR-S1-S-26-100	
	150	32	562620	EAPR-S1-S-26-150	
	200	37	562621	EAPR-S1-S-26-200	
With standard slide or slide, short					
33	100/130-S	51	562622	EAPR-S1-S-33-100/130-S	
	200/230-S	69	562623	EAPR-S1-S-33-200/230-S	
	300/330-S	88	562624	EAPR-S1-S-33-300/330-S	
	400/430-S	106	562625	EAPR-S1-S-33-400/430-S	
	500/530-S	125	562626	EAPR-S1-S-33-500/530-S	
	600/630-S	144	562627	EAPR-S1-S-33-600/630-S	
46	200/240-S	78	562628	EAPR-S1-S-46-200/240-S	
	300/340-S	97	562629	EAPR-S1-S-46-300/340-S	
	400/440-S	115	562630	EAPR-S1-S-46-400/440-S	
	500/540-S	134	562631	EAPR-S1-S-46-500/540-S	
	600/640-S	153	562632	EAPR-S1-S-46-600/640-S	
	800/840-S	190	562633	EAPR-S1-S-46-800/840-S	

## Electric slides EGSK/EGSP



Accessories

**FESTO**

Ordering data – Centring pins, centring sleeves					
	For size	Comment	Part No.	Type	PU <sup>1)</sup>
	15	For slide	189652	ZBH-5	10
	20		525273	ZBS-2	
	26, 46		150928	ZBS-5	
	33		562959	ZBS-4	
	15, 33	For slide adapter	562959	ZBS-4	
	20		525273	ZBS-2	
	26, 46		150928	ZBS-5	

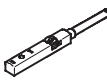
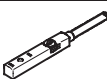
1) Packaging unit quantity

Ordering data – Proximity sensors for T-slot, inductive						Technical data → Internet: sies	
	Type of mounting	Switching output	Electrical connection	Cable length [m]	Part No.	Type	
<b>N/O contact</b>							
	Insertable in slot from above, flush with sensor strip	PNP	Cable, 3-wire	7.5	551386	SIES-8M-PS-24V-K-7,5-OE	
			Plug M8x1, 3-pin	0.3	551387	SIES-8M-PS-24V-K-0,3-M8D	
		NPN	Cable, 3-wire	7.5	551396	SIES-8M-NS-24V-K-7,5-OE	
			Plug M8x1, 3-pin	0.3	551397	SIES-8M-NS-24V-K-0,3-M8D	
<b>N/C contact</b>							
	Insertable in slot from above, flush with sensor strip	PNP	Cable, 3-wire	7.5	551391	SIES-8M-PO-24V-K-7,5-OE	
			Plug M8x1, 3-pin	0.3	551392	SIES-8M-PO-24V-K-0,3-M8D	
		NPN	Cable, 3-wire	7.5	551401	SIES-8M-NO-24V-K-7,5-OE	
			Plug M8x1, 3-pin	0.3	551402	SIES-8M-NO-24V-K-0,3-M8D	

Ordering data – Connecting cables					Technical data → Internet: nebu	
	Electrical connection, left	Electrical connection, right	Cable length [m]	Part No.	Type	
	Straight socket, M8x1, 3-pin	Cable, open end, 3-wire	2.5	541333	NEBU-M8G3-K-2.5-LE3	
			5	541334	NEBU-M8G3-K-5-LE3	
	Angled socket, M8x1, 3-pin	Cable, open end, 3-wire	2.5	541338	NEBU-M8W3-K-2.5-LE3	
			5	541341	NEBU-M8W3-K-5-LE3	