

Electric cylinders DNCE, with piston rod



Electric cylinders DNCE, with piston rod

Key features

Key features at a glance

General information

The electric cylinder DNCE is a mechanical linear axis with piston rod. The drive component consists of an electrically driven spindle, which converts the rotation of the motor into the linear motion of the piston rod.

The mechanical interfaces are largely compatible with the standard cylinder DNC.

Features

- Choice of spindle type:
 - with lead screw (LS)
 - with ball screw (BS)
- Electric piston rod cylinder with lead screw is self-retarding
- Compact dimensions

Range of applications

- Electric cylinder with lead screw
 - For applications with slow feed speeds
- Electric cylinder with ball screw
 - For applications with high feed speeds and high running performance

Entire system consists of electric cylinder, motor and motor mounting kit

Electric piston rod cylinder

→ 6

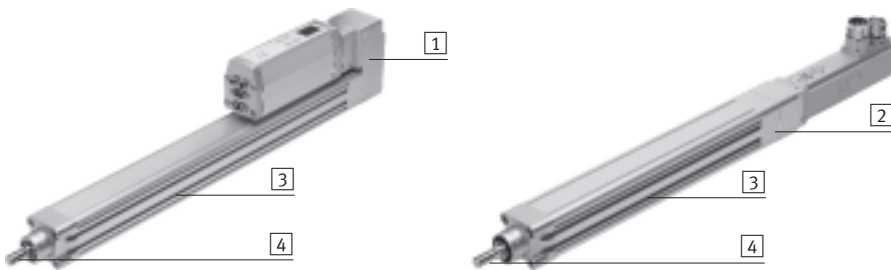

- 1 Parallel kit
- 2 Axial kit
- 3 Slot for proximity sensor
- 4 Options:
 - linear drive with lead screw (LS)
 - linear drive with ball screw (BS)

Note

The linear drive with lead screw is self-retarding, which means that slow movements cannot be excluded in the event of vibration.

The entire system with intelligent motor unit MTR-DCI is self-locking.

Motor/motor unit

→ 17

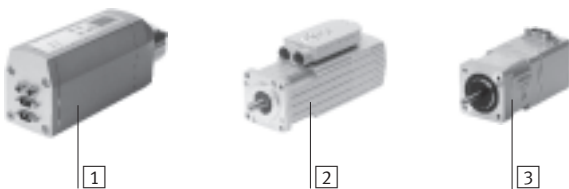

- 1 Intelligent motor unit MTR-DCI
- 2 Servo motor EMMS-AS
- 3 Stepper motor EMMS-ST

Note

A range of specially adapted complete solutions is available for the electric

piston rod cylinder DNCE and the motors/motor units.

Motor mounting kit

→ 17

Axial kit

Parallel kit



There are complete kits for both parallel and axial motor attachment.

Electric cylinders DNCE, with piston rod

Type codes

FESTO

		DNCE	-	32	-	100	-	LS	-	"1,5"P	-	Q
Type												
DNCE	Electric piston rod cylinder											
Size												
Stroke [mm]												
Drive function												
LS	Linear drive with lead screw											
BS	Linear drive with ball screw											
Spindle pitch [mm]												
Protection against rotation												
Q	Non-rotating piston rod											

Electric cylinders DNCE, with piston rod

Peripherals overview

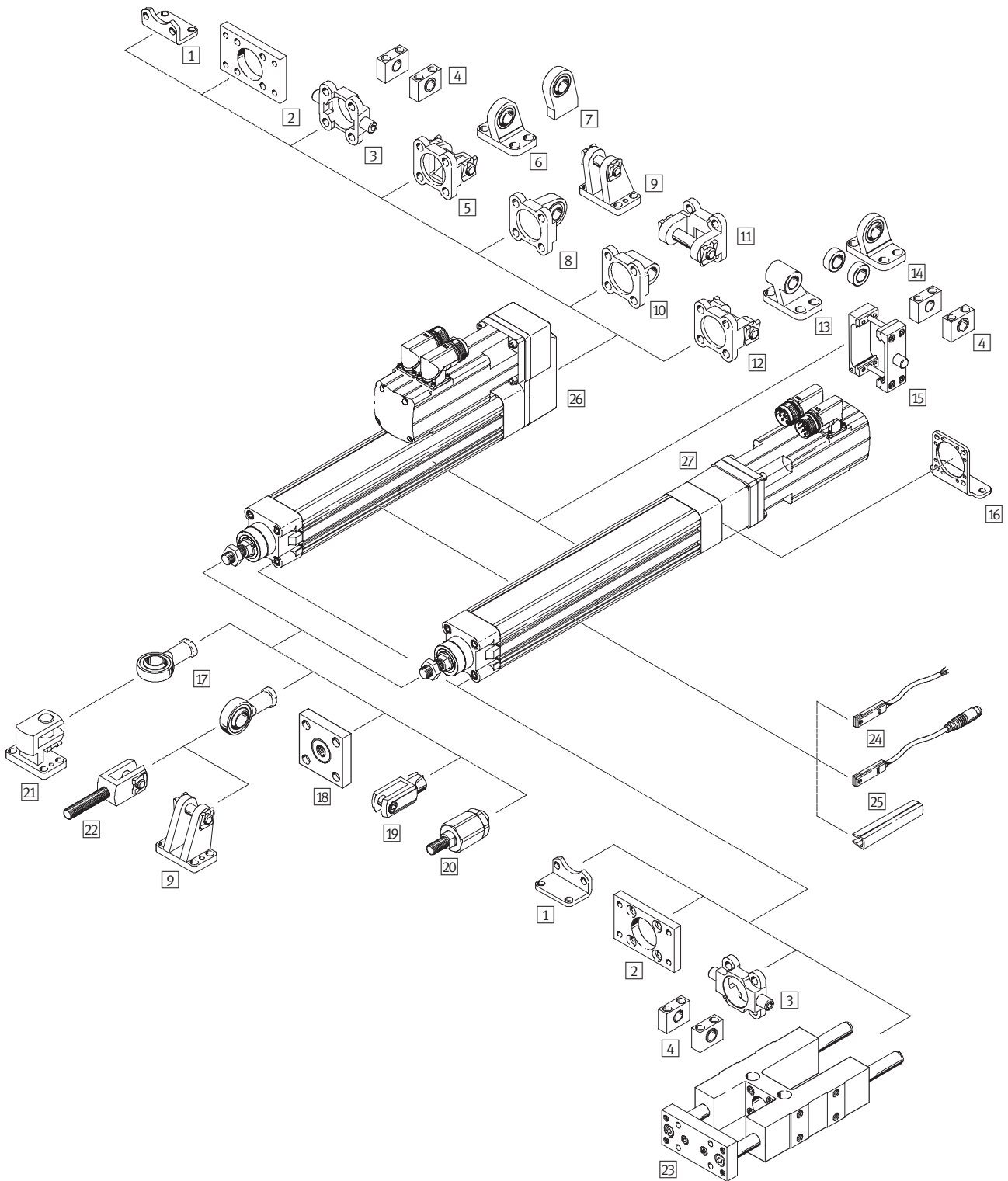

Electric cylinders DNCE, with piston rod

Peripherals overview

Mounting attachments and accessories		
	Brief description	→ Page/Internet
1	Foot mounting HNC/CRHNC – With parallel motor attachment for bearing and gear unit end caps – With axial motor attachment for bearing end caps	24
2	Flange mounting FNC/CRFNG – With parallel motor attachment for bearing and gear unit end caps – With axial motor attachment for bearing end caps	25
3	Trunnion flange ZNC/CRZNG – With parallel motor attachment for bearing and gear unit end caps – With axial motor attachment for bearing end caps	26
4	Trunnion support LNZG/CRLNZG For cylinders with trunnion mounting	27
5	Swivel flange SNC With parallel motor attachment	28
6	Clevis foot LSNG With parallel motor attachment, with spherical bearing	31
7	Clevis foot LSNSG With parallel motor attachment, weld-on, with spherical bearing	31
8	Swivel flange SNCS With parallel motor attachment, with spherical bearing	28
9	Clevis foot LBG With parallel motor attachment, with spherical bearing	31
10	Swivel flange SNCL With parallel motor attachment	29
11	Swivel flange SNCB/SNCB-...-R3 With parallel motor attachment, with spherical bearing	30
12	Swivel flange SNCB/SNCB-...-R3 With parallel motor attachment	30
13	Clevis foot LNG/CRLNG With parallel motor attachment	31
14	Clevis foot LSN With parallel motor attachment, with spherical bearing	31
15	Trunnion mounting kit ZNCM For mounting anywhere along the cylinder profile barrel. Cannot be mounted in the vicinity of the motor with parallel motor attachment	31
16	Foot mounting HNCE With axial motor attachment	23
17	Rod eye SGS/CRSGS With spherical bearing	32
18	Coupling piece KSZ To compensate for radial deviations	32
19	Rod clevis SG/CRSG Permits a swivelling movement of the cylinder in one plane	32
20	Self-aligning rod coupler FK To compensate for radial and angular deviations	32
21	Clevis foot LQG For rod eye SGS	32
22	Rod clevis SGA For swivel attachment of cylinders	32
23	Guide unit FENG For protecting standard cylinders against rotation at high torque loads	32
24	Proximity sensor SME/SMT-8 For position sensing. Can be integrated in sensor slot, thus no projecting parts	33
25	Slot cover ABP-5-S For protecting against the ingress of dirt	33
26	Parallel kit EAMM-U For parallel motor attachment	17
27	Axial kit EAMM-A For axial motor attachment	17



Electric cylinders DNCE, with piston rod

Technical data

FESTO

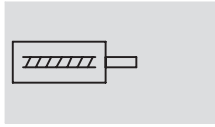
Function



-  Size
32 ... 63
-  Stroke length
1 ... 800 mm
-  www.festo.com

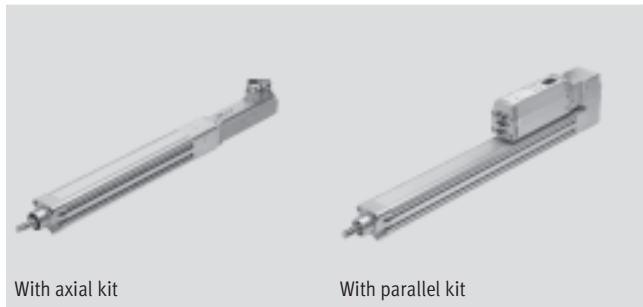

General technical data		32	40	63
Size		32	40	63
Constructional design	LS	With lead screw		
	BS	With ball screw		
Piston rod thread		M10x1.25	M12x1.25	M16x1.5
Working stroke		1 ... 400	1 ... 600	1 ... 800
Variant		Non-rotating piston rod		
Protection against torsion/guide		Plain bearing guide		
Stroke reserve	[mm]	0		
Max. angle of rotation at the piston rod	[°]	±0.30	±0.25	±0.20
Impact energy (E) at the end positions	[J]	0.0001 $E = 0.5 \times m \times v^2$	0.0002 $E = 0.5 \times m \times v^2$	0.0004 $E = 0.5 \times m \times v^2$
Duty cycle ¹⁾	[%]	100		
Position sensing		Via proximity sensor		
Type of mounting		Via female threads		
		Via accessories		
Mounting position		Any		

1) In the case of the variant with lead screw (LS), the duty cycle depends on the speed

Mechanical data		32			40			63		
Size		LS-"1,5"P	BS-"3"P	BS-"10"P	LS-"2,5"P	BS-"5"P	BS-"12,7"P	LS-"4"P	BS-"10"P	BS-"20"P
Spindle pitch	[mm/rev.]	1.5	3	10	2.5	5	12.7	4	10	20
Spindle diameter	[mm]	9	10	10	12.5	12	12.7	20	20	20
Max. static axial force	[N]	600	600	600	1,400	1,400	1,400	3,700	3,700	3,700
Max. feed force F_x ¹⁾	[N]	300	300	350	600	525	800	1,000	2,500	1,625
Continuous feed force ¹⁾	[N]	300	240	280	600	420	640	1,000	2,000	1,300
Max. driving torque ²⁾	[Nm]	0.4	0.4	0.8	1.15	0.9	1.9	3	4.9	5.9
No-load driving torque with axial kit ³⁾	[Nm]	0.08	0.08	0.08	0.12	0.12	0.12	0.3	0.2	0.2
No-load driving torque with parallel kit ³⁾	[Nm]	0.13	0.13	0.13	0.22	0.22	0.22	0.6	0.5	0.5
Continuous driving torque	[Nm]	0.4	0.3	0.6	1.15	0.8	1.6	3	4.1	4.8
Max. radial force ⁴⁾	[N]	120	120	120	260	260	260	300	300	300
Max. speed	[m/s]	0.06	0.15	0.5	0.07	0.25	0.64	0.07	0.5	1.0
Max. rotational speed		2,400	3,000	3,000	1,650	3,000	3,000	1,050	3,000	3,000
Max. acceleration	[m/s ²]	1	6	6	1	6	6	1	6	6
Reversing backlash ⁵⁾	[mm]	0.2	0.05	0.05	0.2	0.05	0.05	0.2	0.05	0.05
Repetition accuracy	[mm]	±0.07	±0.02	±0.02	±0.07	±0.02	±0.02	±0.07	±0.02	±0.02

- 1) The feed force in the case of the variant with lead screw (LS) depends on the speed → 9
The feed force in the case of the variant with ball screw (BS) → 7
- 2) The driving torque in the case of the variant with lead screw (LS) depends on the rotational speed → 10
- 3) Measured at a speed of 200 rpm
- 4) On drive shaft
- 5) In new condition

Electric cylinders DNCE, with piston rod

Technical data

Operating and environmental conditions		
Ambient temperature ¹⁾²⁾	[°C]	0 ... 50
Storage temperature	[°C]	-25 ... +60
Protection class ²⁾		IP40
Relative air humidity	[%]	0 ... 95

- 1) Note operating range of proximity sensors and motors
2) Higher protection class and other ambient conditions on request

Weight [g]									
Size	32			40			63		
Spindle design	LS-™1,5™P	BS-™3™P	BS-™10™P	LS-™2,5™P	BS-™5™P	BS-™12,7™P	LS-™4™P	BS-™10™P	BS-™20™P
Basic weight with 0 mm stroke	720	750	770	1,210	1,270	1,350	2,790	3,010	3,010
Additional weight per 10 mm stroke	32.4	33	33.6	46.1	45.5	46.7	79.8	81.2	81.2
Moving load with 0 mm stroke	150	170	200	250	310	380	600	810	810
Moving load per 10 mm stroke	6.9	6.9	6.9	8.9	8.9	8.9	12.8	12.8	12.8

Mass moment of inertia										
Size	32			40			63			
Spindle design	LS-™1,5™P	BS-™3™P	BS-™10™P	LS-™2,5™P	BS-™5™P	BS-™12,7™P	LS-™4™P	BS-™10™P	BS-™20™P	
J ₀ with 0 mm stroke	[kg cm ²]	0.0433	0.0439	0.0446	0.1316	0.1304	0.1337	0.7565	0.7626	0.7624
j _H per metre stroke	[kg cm ² /m]	0.0361	0.0476	0.0595	0.1341	0.1163	0.1572	0.8176	0.9090	0.9103
j _L per kg working load	[kg cm ² /kg]	0.0006	0.0023	0.0253	0.0016	0.0063	0.0409	0.0041	0.0253	0.1013

The mass moment of inertia J_A of the electric cylinder is calculated as follows:

$$J_A = J_0 + j_H \times \text{working stroke [m]} + j_L \times m_{\text{working load [kg]}}$$

Calculation of the feed force F_{xm} for the electric cylinder DNCE with ball screw (BS)

The peak feed force value must not exceed the maximum feed force within a movement cycle. In the case of vertical operation, the peak value is generally

achieved during the acceleration phase of the upwards stroke. If the maximum feed force is exceeded, this can increase wear and thus shorten

the service life of the ball screw. The maximum speed must likewise not be exceeded.

$$F_x \leq F_{x\text{max}}$$

and

$$v_x \leq v_{x\text{max}}$$

Mean feed force (to DIN 69 051-4)

During operation, the continuous feed force may be briefly exceeded up to the maximum feed force. The

continuous feed force must, however, be adhered to when averaged over a movement cycle.

$$F_{xm} \leq F_{x\text{dauer}}$$

$$F_{xm} = \sqrt[3]{\sum F_x^3 \times \frac{v_x}{v_{xm}} \times \frac{q}{100}} =$$

$$F_{xm} = \sqrt[3]{F_{x1}^3 \times \frac{v_{x1}}{v_{xm}} \times \frac{q_1}{100} + F_{x2}^3 \times \frac{v_{x2}}{v_{xm}} \times \frac{q_2}{100} + F_{x3}^3 \times \frac{v_{x3}}{v_{xm}} \times \frac{q_3}{100} + \dots}$$

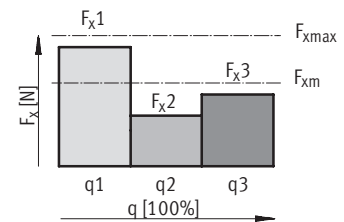

Mean feed speed (to DIN 69 051-4)

$$v_{xm} = \sum v_x \times \frac{q}{100} = v_{x1} \times \frac{q_1}{100} + v_{x2} \times \frac{q_2}{100} + v_{x3} \times \frac{q_3}{100} + \dots$$

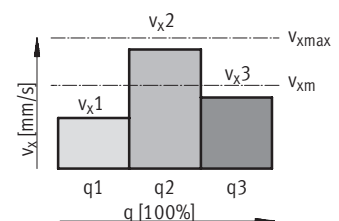

F _x	Feed force	v _x	Feed speed
F _{xm}	Mean feed force	v _{xm}	Mean feed speed
F _{xmax}	Max. feed force	v _{xmax}	Max. feed speed
F _{xcont}	Continuous feed force		
q	Time		

Electric cylinders DNCE, with piston rod

Technical data

Materials

Sectional view

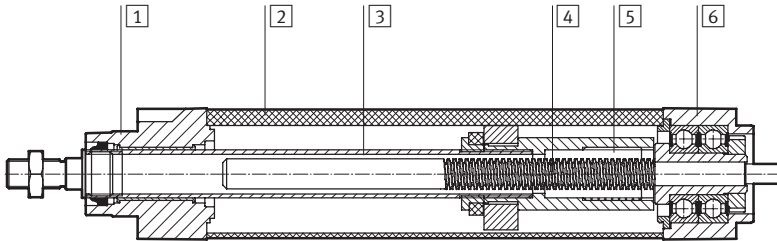

Electric cylinder

1	Bearing cap	Die-cast aluminium, painted
2	Cylinder barrel	Wrought aluminium alloy, smooth anodised
3	Piston rod	High-alloy stainless steel
4	Spindle	Steel
5	Spindle nut for LS	Polyacetate
	Spindle nut for BS	Steel
6	Drive cover	Die-cast aluminium, painted

Maximum permissible loads on the piston rod

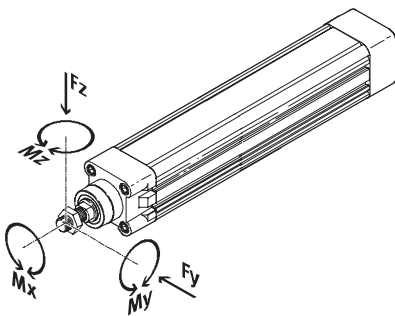

If there are two or more forces and torques simultaneously acting upon the piston rod, the following equations must be satisfied:

$$\frac{|F_y|}{F_{y_{max}}} + \frac{|F_z|}{F_{z_{max}}} + \frac{|M_y|}{M_{y_{max}}} + \frac{|M_z|}{M_{z_{max}}} \leq 1$$

$$|F_x| \leq F_{x_{max}}$$

$$|M_x| \leq M_{x_{max}}$$

Maximum permissible lateral forces $F_{y_{max}}$ and $F_{z_{max}}$ on the piston rod

Horizontal mounting position

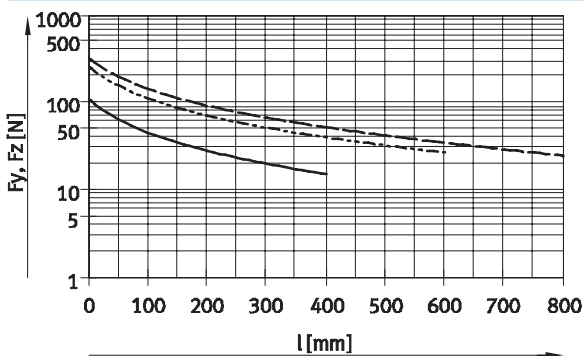

— DNCE-32-LS/BS
- - - DNCE-40-LS/BS
- · - DNCE-63-LS/BS

Vertical mounting position

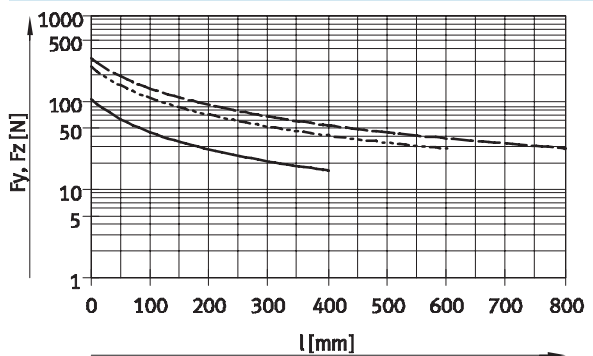

— DNCE-32-LS/BS
- - - DNCE-40-LS/BS
- · - DNCE-63-LS/BS

Note

Sizing software
PositioningDrives
→ www.festo.com

Size		32	40	63
Maximum permissible forces and torques				
$F_{x_{max}}$ (static)	[N]	600	1,400	3,700
$M_{x_{max}}$	[Nm]	1	1	1.5
$M_{y_{max}}, M_{z_{max}}$	[Nm]	8	20	27

Electric cylinders DNCE, with piston rod

Technical data

Feed force F as a function of speed v

DNCE-32-1...299-LS-...

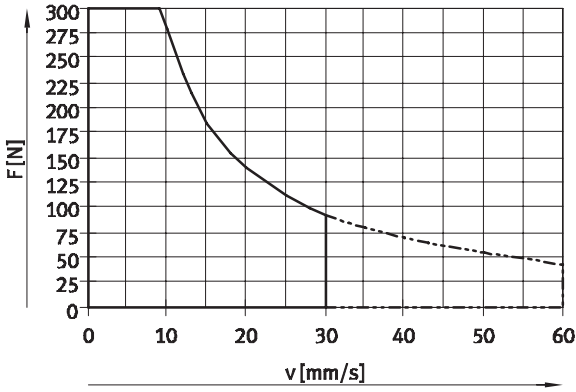

DNCE-32-300...400-LS-...

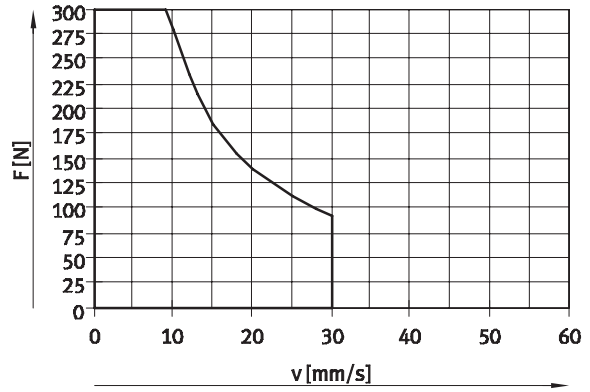

DNCE-40-1...299-LS-...

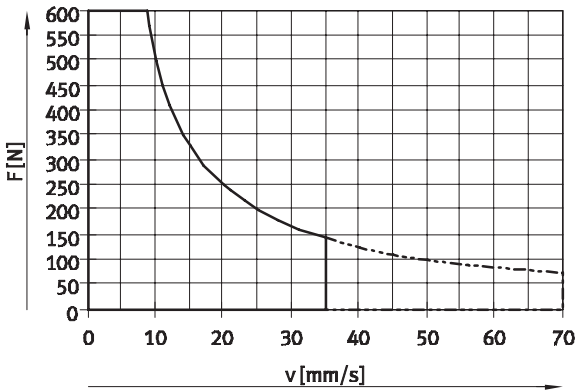

DNCE-40-300...600-LS-...

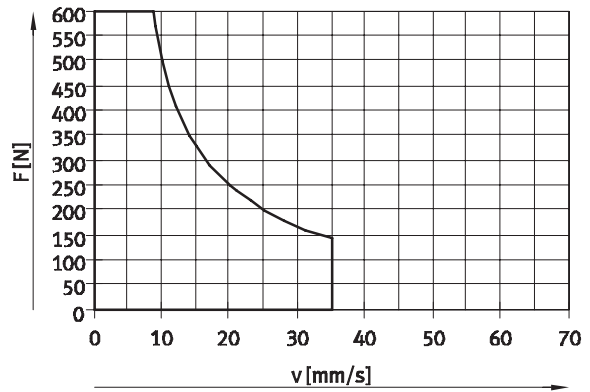

DNCE-63-1...419-LS-...

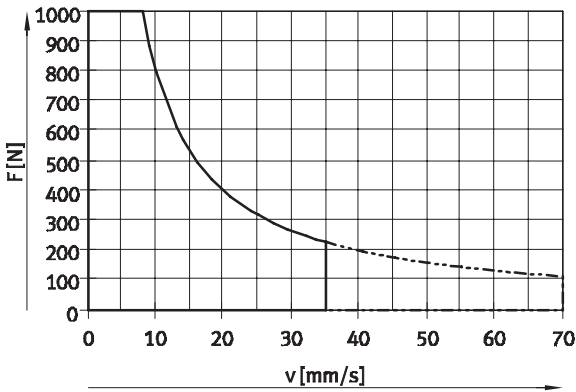

DNCE-63-420...800-LS-...

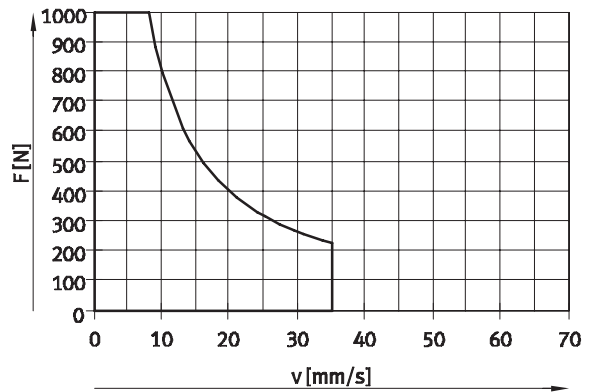

- Recommended operating range
- - - Permissible operating range
(duty cycle < 50% recommended)

Electric cylinders DNCE, with piston rod

Technical data

Driving torque M as a function of rotational speed n

DNCE-32-1...299-LS-...

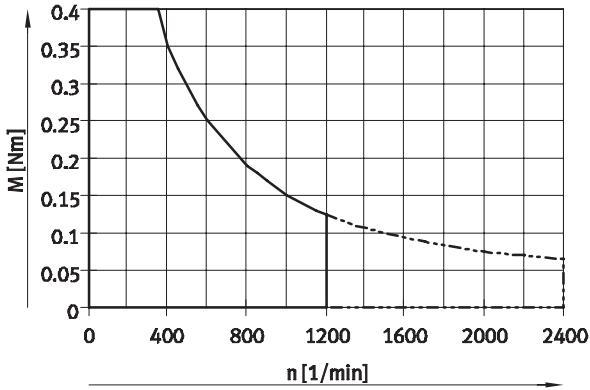

DNCE-32-300...400-LS-...

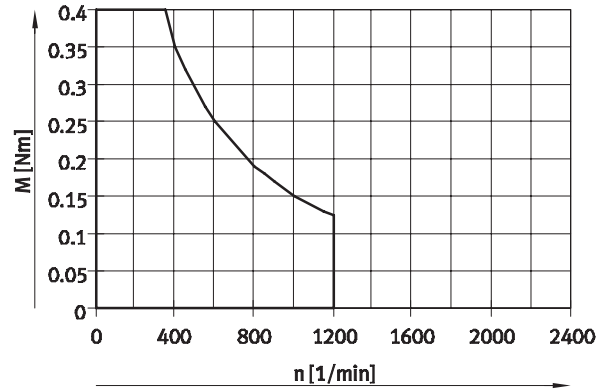

DNCE-40-1...299-LS-...

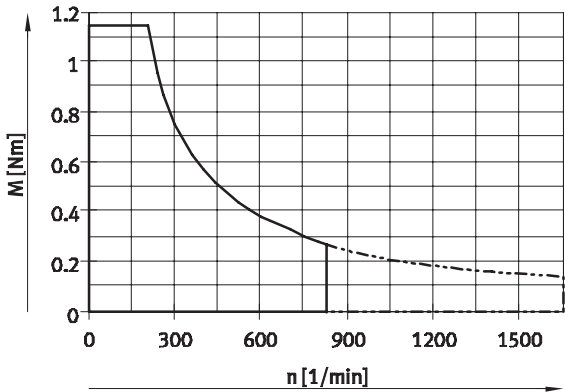

DNCE-40-300...600-LS-...

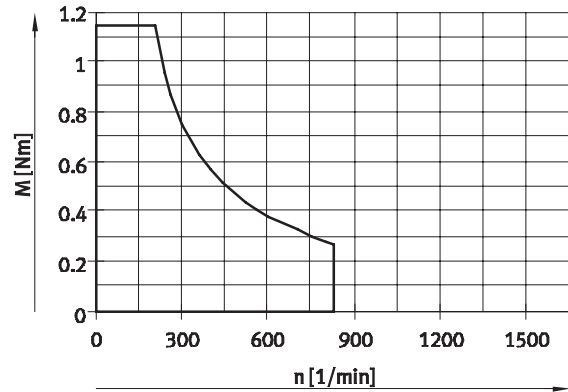

DNCE-63-1...419-LS-...

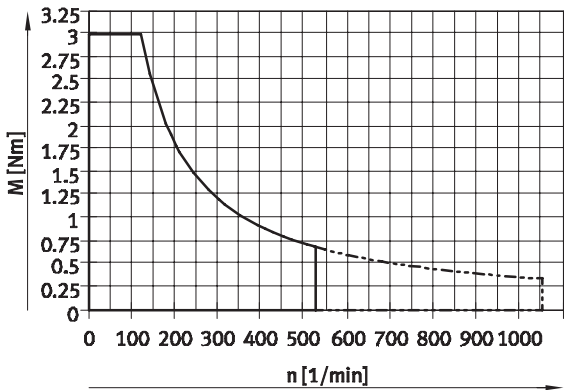

DNCE-63-420...800-LS-...

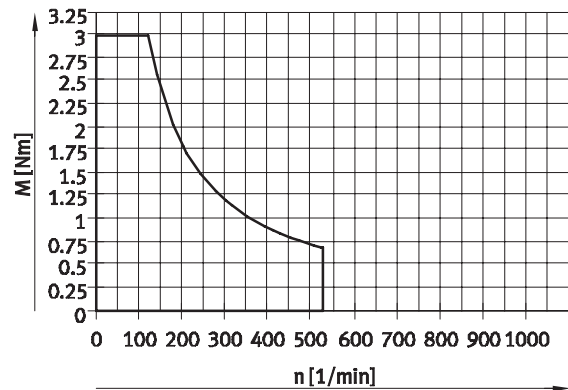

- Recommended operating range
- - - Permissible operating range
(duty cycle < 50% recommended)

Electric cylinders DNCE, with piston rod

Technical data

Rotational speed n as a function of speed v

DNCE-...-LS-...

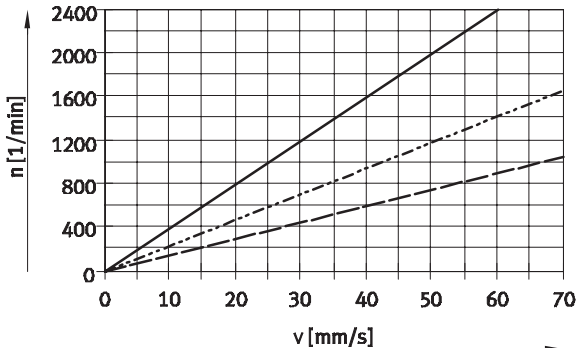

- DNCE-32-LS-1,5°P
- - - DNCE-40-LS-2,5°P
- · - DNCE-63-LS-4°P

DNCE-...-BS-...

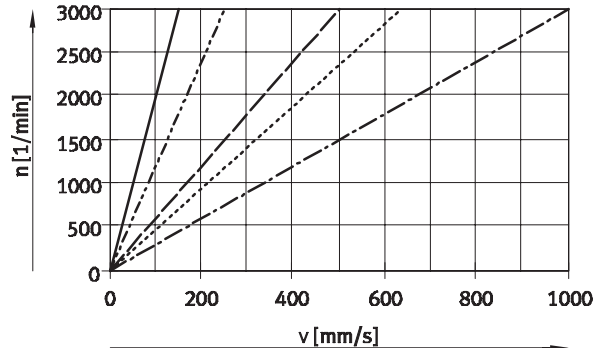

- DNCE-32-BS-3°P
- - - DNCE-32-BS-10°P
- · - DNCE-40-BS-5°P
- · - DNCE-40-BS-12,7°P
- · - DNCE-63-BS-10°P
- · - DNCE-63-BS-20°P

Driving torque M as a function of feed force F



Note

In the diagrams the moments of friction at room temperature are taken into account.

At lower temperatures the moments of friction of the DNCE-...-LS (slide thread) will increase.

Sizing software
PositioningDrives
→ www.festo.com

DNCE-...-LS-...

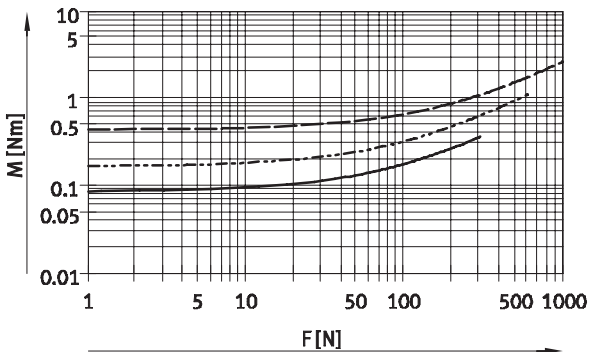

- DNCE-32-LS-1,5°P
- - - DNCE-40-LS-2,5°P
- · - DNCE-63-LS-4°P

DNCE-...-BS-...

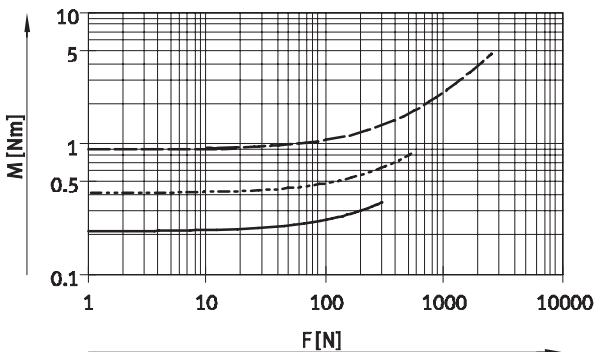

- DNCE-32-BS-3°P
- - - DNCE-40-BS-5°P
- · - DNCE-63-BS-10°P

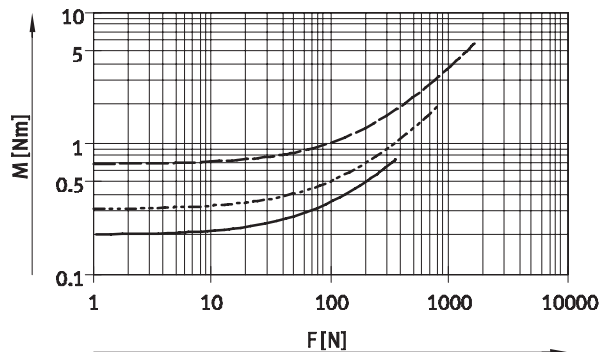

- DNCE-32-BS-10°P
- - - DNCE-40-BS-12,7°P
- · - DNCE-63-BS-20°P

Electric cylinders DNCE, with piston rod

Technical data

Piston rod displacement f as a function of stroke length l

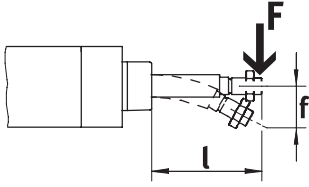

DNCE-32-...

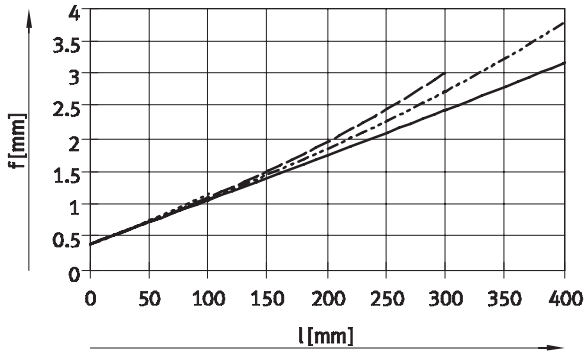

- Lateral force $F = 0$ N
- - - Lateral force $F = 10$ N
- · - Lateral force $F = 20$ N
- · · - Lateral force $F = 45$ N

DNCE-40-...

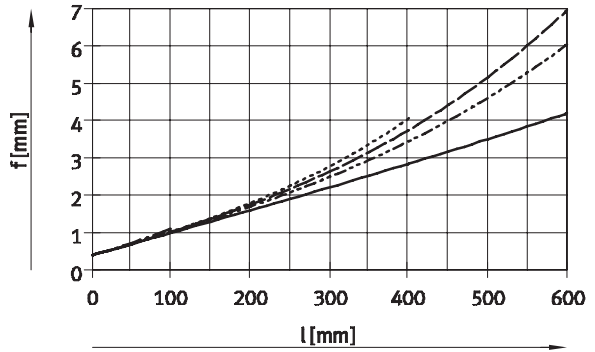

- Lateral force $F = 0$ N
- - - Lateral force $F = 20$ N
- · - Lateral force $F = 30$ N
- · · - Lateral force $F = 40$ N
- · · · - Lateral force $F = 115$ N

DNCE-63-...

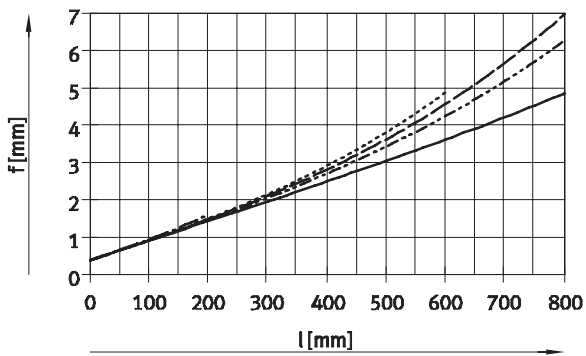

- Lateral force = 0 N
- - - Lateral force = 20 N
- · - Lateral force = 30 N
- · · - Lateral force = 40 N
- · · · - Lateral force = 95 N

Electric cylinders DNCE, with piston rod

Technical data

Running performance L as a function of mean feed force F (to DIN 69 051-4)

DNCE-32-...-BS-...

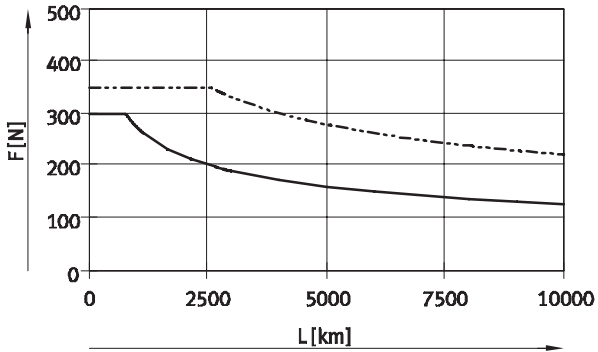

— DNCE-32-BS-10P
- - - DNCE-32-BS-12,5P

DNCE-40-...-BS-...

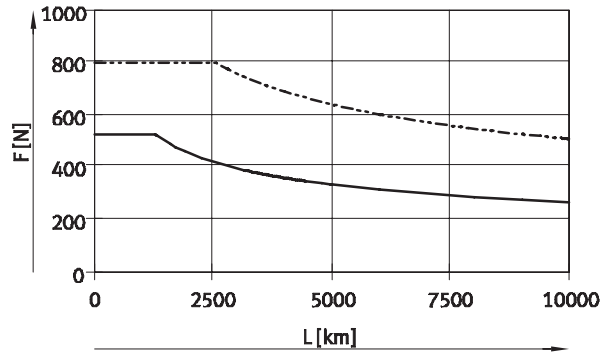

— DNCE-40-BS-5P
- - - DNCE-40-BS-12,5P

DNCE-63-...-BS-...

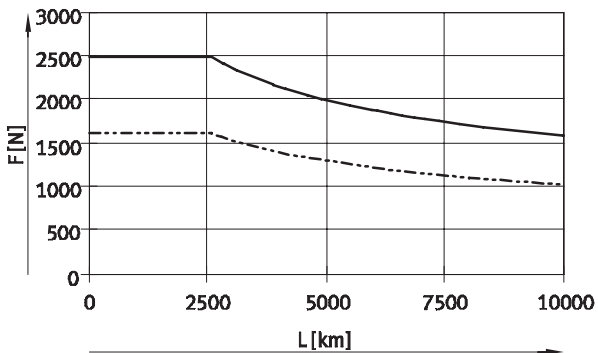

— DNCE-63-BS-10P
- - - DNCE-63-BS-20P

Note

- The data on running performance is based on empirically determined and theoretically calculated data. The running performance attainable in practice may deviate from the indicated curves if the parameters are different.
- Characteristic for DNCE-63-BS-10P applies to a mean speed of 1,500 rpm.
- Characteristic for all other DNCE-...-BS applies to a maximum speed of 3,000 rpm.

Electric cylinders DNCE, with piston rod

Technical data

Dimensions

Download CAD data → www.festo.com

Electric cylinder DNCE

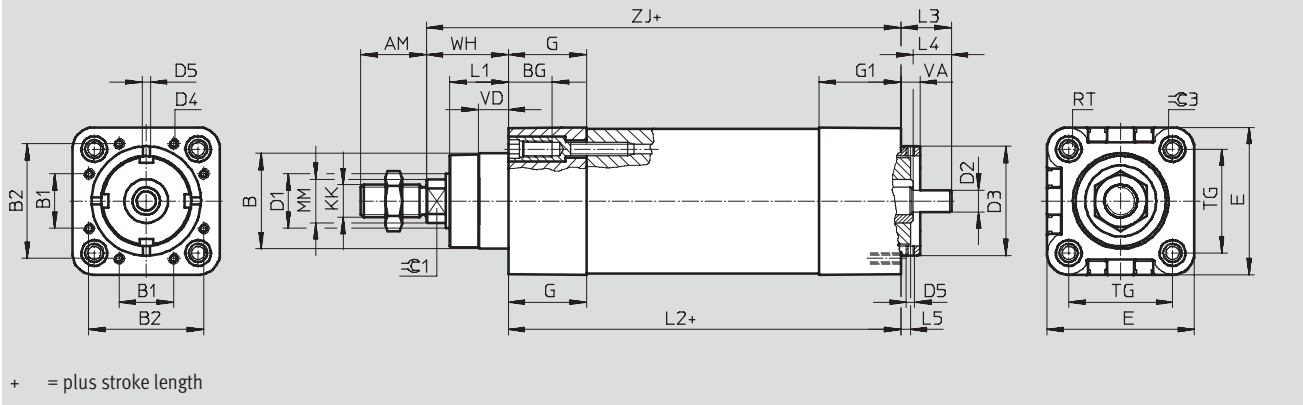

Size	AM	B	B1	B2	BG	D1	D2	D3	D4	D5	E	G	G1	KK
[mm]		∅ d11				∅ h9	∅ h6	∅ f7						
32	22	30	19	32	16	16	6	32	M3	M3	45.5	24	26	M10x1.25
40	24	35	20	42	16	20	8	40	M4	M3	54	28.5	30	M12x1.25
63	32	45	31	62	17	28	12	60	M5	M4	75.5	34	36	M16x1.5

Size	L1	L2	L3	L4	L5	MM	RT	TG	VA	VD	WH	ZJ	∅C1	∅C3
[mm]												±1		
32	18	122	15.9	8	3.5	12	M6	32.5	7	10	26	148	10	6
40	21.5	146.5	18.4	14	3.5	16	M6	38	7	10.5	30	176.5	13	6
63	28.5	177	23.5	17	4.5	20	M8	56.5	9	15	37	214	17	8

Electric cylinders DNCE, with piston rod

Technical data

Ordering data – DNCE-32							
Stroke [mm]	Part No.	Type		Stroke [mm]	Part No.	Type	
Ball screw drive with spindle pitch 3 mm				Lead screw drive with spindle pitch 1.5 mm			
100	543 115	DNCE-32-100-BS-”3”P-Q		100	543 111	DNCE-32-100-LS-”1,5”P-Q	
200	543 116	DNCE-32-200-BS-”3”P-Q		200	543 112	DNCE-32-200-LS-”1,5”P-Q	
300	543 117	DNCE-32-300-BS-”3”P-Q		300	543 113	DNCE-32-300-LS-”1,5”P-Q	
400	543 118	DNCE-32-400-BS-”3”P-Q		400	543 114	DNCE-32-400-LS-”1,5”P-Q	
Ball screw drive with spindle pitch 10 mm							
100	543 119	DNCE-32-100-BS-”10”P-Q					
200	543 120	DNCE-32-200-BS-”10”P-Q					
300	543 121	DNCE-32-300-BS-”10”P-Q					
400	543 122	DNCE-32-400-BS-”10”P-Q					

Ordering data – DNCE-40							
Stroke [mm]	Part No.	Type		Stroke [mm]	Part No.	Type	
Ball screw drive with spindle pitch 5 mm				Lead screw drive with spindle pitch 2.5 mm			
100	543 127	DNCE-40-100-BS-”5”P-Q		100	543 123	DNCE-40-100-LS-”2,5”P-Q	
200	543 128	DNCE-40-200-BS-”5”P-Q		200	543 124	DNCE-40-200-LS-”2,5”P-Q	
300	555 466	DNCE-40-300-BS-”5”P-Q		300	555 465	DNCE-40-300-LS-”2,5”P-Q	
400	543 129	DNCE-40-400-BS-”5”P-Q		400	543 125	DNCE-40-400-LS-”2,5”P-Q	
600	543 130	DNCE-40-600-BS-”5”P-Q		600	543 126	DNCE-40-600-LS-”2,5”P-Q	
Ball screw drive with spindle pitch 12.7 mm							
100	543 131	DNCE-40-100-BS-”12,7”P-Q					
200	543 132	DNCE-40-200-BS-”12,7”P-Q					
300	555 467	DNCE-40-300-BS-”12,7”P-Q					
400	543 133	DNCE-40-400-BS-”12,7”P-Q					
600	543 134	DNCE-40-600-BS-”12,7”P-Q					

Ordering data – DNCE-63							
Stroke [mm]	Part No.	Type		Stroke [mm]	Part No.	Type	
Ball screw drive with spindle pitch 10 mm				Lead screw drive with spindle pitch 4 mm			
100	555 470	DNCE-63-100-BS-”10”P-Q		100	555 468	DNCE-63-100-LS-”4”P-Q	
200	543 139	DNCE-63-200-BS-”10”P-Q		200	543 135	DNCE-63-200-LS-”4”P-Q	
300	555 471	DNCE-63-300-BS-”10”P-Q		300	555 469	DNCE-63-300-LS-”4”P-Q	
400	543 140	DNCE-63-400-BS-”10”P-Q		400	543 136	DNCE-63-400-LS-”4”P-Q	
600	543 141	DNCE-63-600-BS-”10”P-Q		600	543 137	DNCE-63-600-LS-”4”P-Q	
800	543 142	DNCE-63-800-BS-”10”P-Q		800	543 138	DNCE-63-800-LS-”4”P-Q	
Ball screw drive with spindle pitch 20 mm							
100	555 472	DNCE-63-100-BS-”20”P-Q					
200	543 143	DNCE-63-200-BS-”20”P-Q					
300	555 473	DNCE-63-300-BS-”20”P-Q					
400	543 144	DNCE-63-400-BS-”20”P-Q					
600	543 145	DNCE-63-600-BS-”20”P-Q					
800	543 146	DNCE-63-800-BS-”20”P-Q					

 Note
Variable strokes can be ordered via the modular product system
→ 16

Electric cylinders DNCE, with piston rod

Ordering data – Modular products

Mandatory data						
Module No.	Function	Size	Stroke	Drive type	Spindle pitch	Protection against rotation
555 488	DNCE	32	1 ... 800	LS BS	"..."P	Q
555 489		40				
555 490		63				
Order example						
555 489	DNCE	40	550	LS	"2,5"P	Q

Ordering table						
Size	32	40	63	Condi- tions	Code	Enter code
M Module No.	555 488	555 489	555 490			
Function	Electric piston rod cylinder				DNCE	DNCE
Size	32	40	63		-...	
Stroke [mm]	100				-...	
	200					
	300					
	400					
	-	600				
	-	-	800			
Stroke	1 ... 400	1 ... 600	1 ... 800	[1]		
Drive type	Lead screw spindle				-LS	
	Ball screw spindle				-BS	
Spindle pitch [mm]	1.5	-	-	[2]	-"..."P	
	-	2.5	-	[2]		
	3	-	-	[3]		
	-	-	4	[2]		
	-	5	-	[3]		
	10	-	10	[3]		
	-	12.7	-	[3]		
	-	-	20	[3]		
Protection against rotation	Non-rotating piston rod				-Q	-Q

[1] ... Additional stroke lengths upon request

[2] "1,5"P, "2,5"P, "4"P

Only with drive type LS

[3] "3"P, "5"P, "10"P, "12,7"P, "20"P



Only with drive type BS

Transfer order code

	DNCE	-		-		-		-		-	Q
--	-------------	---	--	---	--	---	--	---	--	---	----------

Electric cylinders DNCE, with piston rod

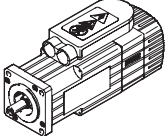
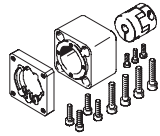
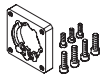
Accessories

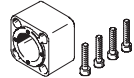
Permissible axis/motor combinations with axial kit				
Motor/motor unit	Axial kit	Axial kit consisting of:		
		Motor flange	Coupling	Coupling housing
				
Type	Part No. Type	Part No. Type	Part No. Type	Part No. Type
DNCE-32				
With servo motor				
EMMS-AS-40-...	543 147 EAMM-A-D32-40A	552 163 EAMF-A-28B-40A	543 420 EAMC-16-20-6-6	552 155 EAMK-A-D32-28B
EMMS-AS-55-...	550 979 EAMM-A-D32-55A	529 942 EAMF-A-44A/B-55A	551 003 EAMC-30-32-6-9	551 006 EAMK-A-D32-44A
With stepper motor				
EMMS-ST-42-...	543 148 EAMM-A-D32-42A	552 164 EAMF-A-28B-42A	543 419 EAMC-16-20-5-6	552 155 EAMK-A-D32-28B
EMMS-ST-57-...	550 980 EAMM-A-D32-57A	530 081 EAMF-A-44A/B-57A	551 002 EAMC-30-32-6-6.35	551 006 EAMK-A-D32-44A
With intelligent motor unit				
MTR-DCI-32S-... ¹⁾	543 149 EAMM-A-D32-32B	–	543 420 EAMC-16-20-6-6	552 156 EAMK-A-D32-32B
DNCE-40				
With servo motor				
EMMS-AS-55-...	543 153 EAMM-A-D40-55A	529 942 EAMF-A-44A/B-55A	543 423 EAMC-30-32-8-9	552 157 EAMK-A-D40-44A
EMMS-AS-70-...	550 981 EAMM-A-D40-70A	529 943 EAMF-A-44A/B-70A	551 004 EAMC-30-32-8-11	552 157 EAMK-A-D40-44A
With stepper motor				
EMMS-ST-57-...	543 154 EAMM-A-D40-57A	530 081 EAMF-A-44A/B-57A	543 421 EAMC-30-32-6.35-8	552 157 EAMK-A-D40-44A
EMMS-ST-87-...	550 982 EAMM-A-D40-87A	530 082 EAMF-A-44A/B-87A	551 004 EAMC-30-32-8-11	552 157 EAMK-A-D40-44A
With intelligent motor unit				
MTR-DCI-42S-...-G7 ¹⁾	543 155 EAMM-A-D40-42B	–	543 422 EAMC-30-32-8-8	522 158 EAMK-A-D40-42B
MTR-DCI-42S-...-G14 ¹⁾	543 156 EAMM-A-D40-42C	–	543 422 EAMC-30-32-8-8	522 159 EAMK-A-D40-42C

 Note

1) Motor unit MTR-DCI may only be used in conjunction with electric cylinder DNCE-...-LS (slide thread).

Depending on the combination of motor/motor unit and electric cylinder the maximum feed force of the cylinder cannot be reached.

The following tool is available for selecting and sizing the unit:



 Note

Sizing software
PositioningDrives
→ www.festo.com

Electric cylinders DNCE, with piston rod

Accessories

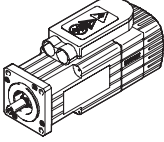
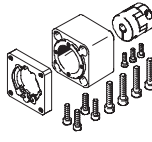
FESTO

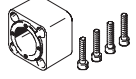
Permissible axis/motor combinations with axial kit				
Motor/motor unit	Axial kit	Axial kit consisting of:		
		Motor flange	Coupling	Coupling housing
				
Type	Part No. Type	Part No. Type	Part No. Type	Part No. Type
DNCE-63				
With servo motor				
EMMS-AS-70-...	543 161 EAMM-A-D60-70A	529 945 EAMF-A-64A/B-70A	543 424 EAMC-42-50-11-12	552 160 EAMK-A-D60-64B
EMMS-AS-100-...	550 983 EAMM-A-D60-100A	529 947 EAMF-A-64A/C-100A	551 005 EAMC-42-50-12-19	551 007 EAMK-A-D60-64C
With stepper motor				
EMMS-ST-87-...	543 162 EAMM-A-D60-87A	530 082 EAMF-A-44A/B-87A	543 424 EAMC-42-50-11-12	552 160 EAMK-A-D60-64B
With intelligent motor unit				
MTR-DCI-52S-...-G7¹⁾	543 163 EAMM-A-D60-52B	–	533 709 EAMC-42-50-12-12	552 161 EAMK-A-D60-52B
MTR-DCI-52S-...-G14¹⁾	543 164 EAMM-A-D60-52C	–	533 709 EAMC-42-50-12-12	552 162 EAMK-A-D60-52C

 - Note

1) Motor unit MTR-DCI may only be used in conjunction with electric cylinder DNCE-...-LS (slide thread).

Depending on the combination of motor/motor unit and electric cylinder the maximum feed force of the cylinder cannot be reached.

The following tool is available for selecting and sizing the unit:

 - Note

Sizing software
PositioningDrives
→ www.festo.com

Electric cylinders DNCE, with piston rod

Accessories

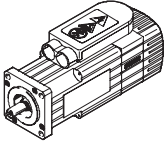
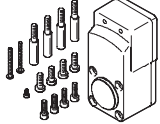
Permissible axis/motor combinations with parallel kit		
Motor/motor unit	Parallel kit	
		
Type	Part No.	Type
DNCE-32		
With servo motor		
EMMS-AS-40-...	543 150	EAMM-U-D32-40A
With intelligent motor unit		
MTR-DCI-32S-...¹⁾	543 152	EAMM-U-D32-32B
DNCE-40		
With servo motor		
EMMS-AS-55-...	543 157	EAMM-U-D40-55A
With intelligent motor unit		
MTR-DCI-42S-G07¹⁾	543 159	EAMM-U-D40-42B
MTR-DCI-42S-G14¹⁾	543 160	EAMM-U-D40-42C
DNCE-63		
With servo motor		
EMMS-AS-70-...	543 165	EAMM-U-D60-70A
With intelligent motor unit		
MTR-DCI-52S-G07¹⁾	543 167	EAMM-U-D60-52B
MTR-DCI-52S-G14¹⁾	543 168	EAMM-U-D60-52C

 Note

1) Motor unit MTR-DCI may only be used in conjunction with electric cylinder DNCE-...-LS (slide thread).

Depending on the combination of motor/motor unit and electric cylinder the maximum feed force of the cylinder cannot be reached.

If parallel kits are used, the relevant no-load driving torque of the kit must be taken into account.

The following tool is available for selecting and sizing the unit:

 Note

Sizing software
PositioningDrives
→ www.festo.com

Electric cylinders DNCE, with piston rod

Accessories

FESTO

Axial kit EAMM-A-...

Material:

Coupling housing: Die-cast aluminium

Coupling hubs: Wrought aluminium alloy

Clamping component: High-alloy steel

Screws: Galvanised steel

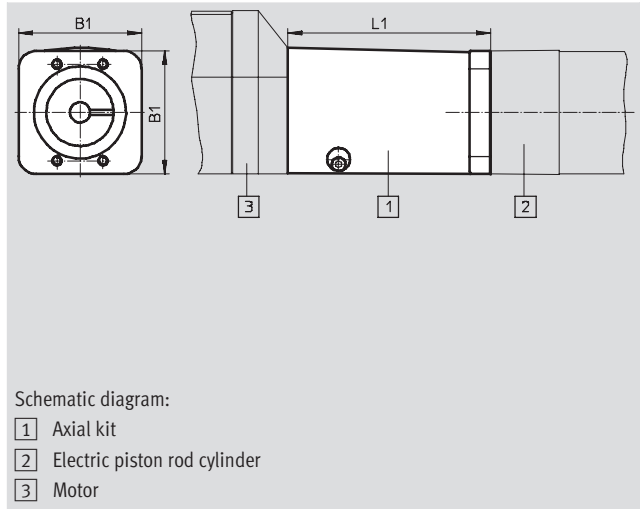

General technical data												
EAMM-A-...		D32-					D40-					
		32B	40A	42A	55A	57A	42B	42C	55A	57A	70A	87A
Transferable torque	[Nm]	1.1	1.1	0.8	4	4	8	8	8	6	8	8
Mass moment of inertia	[kg mm ²]	0.3	0.3	0.3	5.87	5.87	5.87	5.87	5.87	5.87	5.87	5.87
Max. speed	[r.p.m.]	10,000			8,000		8,000					
Mounting position		Any										

EAMM-A-...		D60-					
		52B		52C	70A	87A	100A
Transferable torque	[Nm]	14		14	12	12	14
Mass moment of inertia	[kg mm ²]	35.5		35.5	35.5	35.5	35.5
Max. speed	[r.p.m.]	6,000					
Mounting position		Any					

Operating and environmental conditions		
Ambient temperature	[°C]	0 ... 50
Storage temperature	[°C]	-25 ... +60
Protection class ¹⁾		IP40
Relative air humidity	[%]	0 ... 95

1) Only with combined attachment of motor and axis

Electric cylinders DNCE, with piston rod

Accessories

FESTO

Dimensions and ordering data					
Type	B1	L1	Weight [g]	Part No.	Type
EAMM-A-D32-32B	45	43	150	543 149	EAMM-A-D32-32B
EAMM-A-D32-40A		39.8	130	543 147	EAMM-A-D32-40A
EAMM-A-D32-42A		48	140	543 148	EAMM-A-D32-42A
EAMM-A-D32-55A	55	49.2	260	550 979	EAMM-A-D32-55A
EAMM-A-D32-57A	56.4	50.5	270	550 980	EAMM-A-D32-57A
EAMM-A-D40-42B	53.5	88	340	543 155	EAMM-A-D40-42B
EAMM-A-D40-42C		101	370	543 156	EAMM-A-D40-42C
EAMM-A-D40-55A		49.2	350	543 153	EAMM-A-D40-55A
EAMM-A-D40-57A		50.5	350	543 154	EAMM-A-D40-57A
EAMM-A-D40-70A	70	52	410	550 981	EAMM-A-D40-70A
EAMM-A-D40-87A	85.8	54	530	550 982	EAMM-A-D40-87A
EAMM-A-D60-52B	74	112	930	543 163	EAMM-A-D60-52B
EAMM-A-D60-52C		126	1,020	543 164	EAMM-A-D60-52C
EAMM-A-D60-70A		63.2	750	543 161	EAMM-A-D60-70A
EAMM-A-D60-87A		64.7	890	543 162	EAMM-A-D60-87A
EAMM-A-D60-100A	100	78.2	1,170	550 983	EAMM-A-D60-100A

 Note

Permissible axis/motor combinations

→ 17

Electric cylinders DNCE, with piston rod

Accessories

FESTO

Parallel kit EAMM-U-...

Material:

Coupling housing: Die-cast aluminium

Clamping component, clamping

sleeve, toothed belt gearwheel:

High-alloy steel

Toothed belt: Polychloroprene

Screws: Galvanised steel

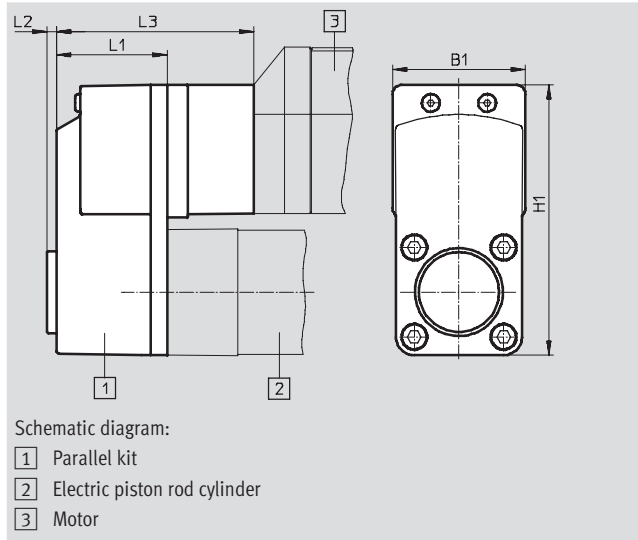

General technical data									
EAMM-U-...		D32-		D40-			D60-		
		32B	40A	42B	42C	55A	52B	52C	70A
Transferable torque	[Nm]	1	1	3	3	3	5.5	5.5	5.5
No-load drive torque	[Nm]	0.05	0.05	0.1	0.1	0.1	0.3	0.3	0.3
Mass moment of inertia	[kgmm ²]	2.931	2.931	10.016	10.016	10.016	70.5	70.5	70.5
Max. speed	[r.p.m.]	3,000							
Mounting position		Any							

Operating and environmental conditions	
Ambient temperature	[°C] 0 ... 50
Storage temperature	[°C] -25 ... +60
Protection class ¹⁾	IP40
Relative air humidity	[%] 0 ... 95

1) Only with combined attachment of motor and axis

Dimensions and ordering data								
Type	B1	H1	L1	L2	L3	Weight [g]	Part No.	Type
EAMM-U-D32-32B	45.1	93.1	40	4	-	300	543 152	EAMM-U-D32-32B
EAMM-U-D32-40A						300	543 150	EAMM-U-D32-40A
EAMM-U-D40-42B	56.5	115	47	4	-	84	543 159	EAMM-U-D40-42B
EAMM-U-D40-42C						97	543 160	EAMM-U-D40-42C
EAMM-U-D40-55A						-	543 157	EAMM-U-D40-55A
EAMM-U-D60-52B	86	162.6	58	4	-	106	543 167	EAMM-U-D60-52B
EAMM-U-D60-52C						120	543 168	EAMM-U-D60-52C
EAMM-U-D60-70A						-	543 165	EAMM-U-D60-70A

Note
 Permissible axis/motor combinations
 → 19

Electric cylinders DNCE, with piston rod

Accessories

FESTO

**Foot mounting HNCE,
for axial motor attachment**

Material:
Galvanised steel

Copper, PTFE and silicone-free

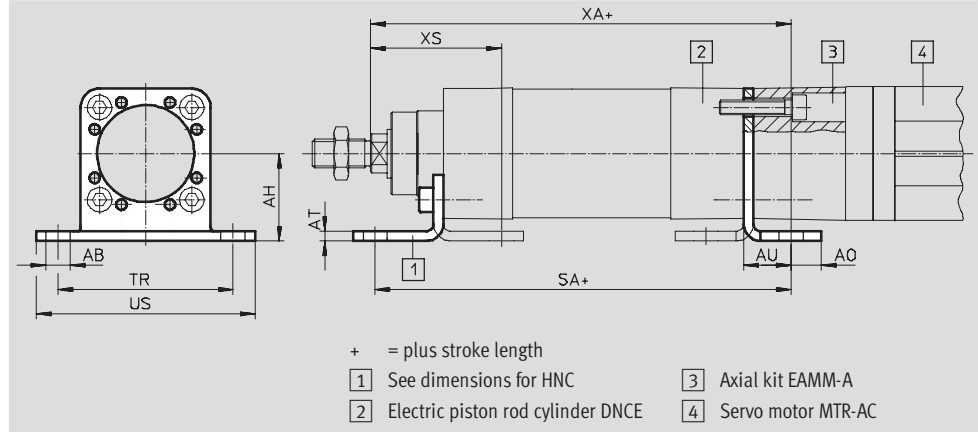

Dimensions and ordering data										
For size	AB	AH	AO	AT	AU	SA	TR	US	XA	XS
[mm]	∅									
32	7	32	10.5	4	17.5	163.5	58	71	165.5	46
40	10	36	12.5	4	19.5	194.5	72	90	196	54
63	10	50	15	5	23	232	92	110	237	64

For size	CRC ¹⁾	Weight	Part No.	Type
[mm]		[g]		
32	1	160	547 949	HNCE-32-AX
40	1	220	547 950	HNCE-40-AX
63	1	470	547 951	HNCE-63-AX

1) Corrosion resistance class 1 to Festo standard 940 070
 Components requiring low corrosion resistance. Transport and storage protection. Parts that do not have primarily decorative surface requirements, e.g. in internal areas that are not visible or behind covers

Electric cylinders DNCE, with piston rod

Accessories

FESTO

Foot mounting HNC/CRHNC,
for parallel motor attachment

Material:
HNC: Galvanised steel

CRHNC: High-alloy steel
Copper, PTFE and silicone-free

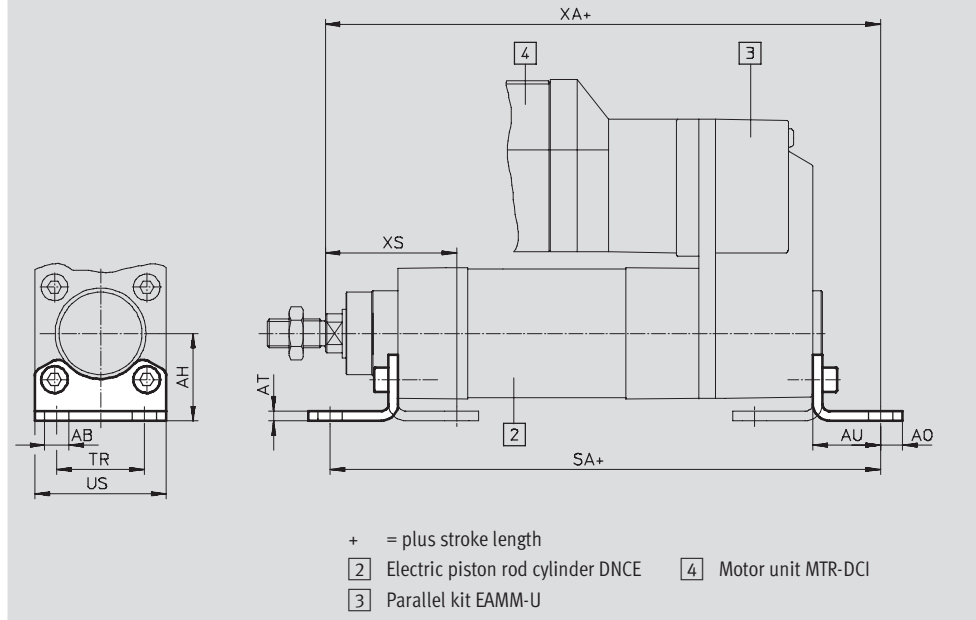

Dimensions and ordering data										
For size	AB	AH	AO	AT	AU	SA	TR	US	XA	XS
[mm]	∅									
32	7	32	6.5	4	24	210	32	45	212	46
40	10	36	9	4	28	249.5	36	54	251.5	54
63	10	50	12.5	5	32	299	50	75	304	64

For size	Basic version				High corrosion protection			
	CRC ¹⁾	Weight [g]	Part No.	Type	CRC ¹⁾	Weight [g]	Part No.	Type
[mm]								
32	2	135	174 369	HNC-32	4	135	176 937	CRHNC-32
40	2	180	174 370	HNC-40	4	180	176 938	CRHNC-40
63	2	405	174 372	HNC-63	4	405	176 940	CRHNC-63

1) Corrosion resistance class 2 to Festo standard 940 070
 Components subject to moderate corrosion stress. Externally visible parts with primarily decorative surface requirements which are in direct contact with a normal industrial environment or media such as coolants or lubricating agents.
 Corrosion resistance class 4 to Festo standard 940 070
 Components requiring higher corrosion resistance. Parts used with aggressive media, e.g. food or chemical industry. These applications should be supported with special tests with the media if required

Electric cylinders DNCE, with piston rod

Accessories

FESTO

Flange mounting FNC/CRFNG

Material:

FNC: Galvanised steel

CRFNG: High-alloy steel

Copper, PTFE and silicone-free

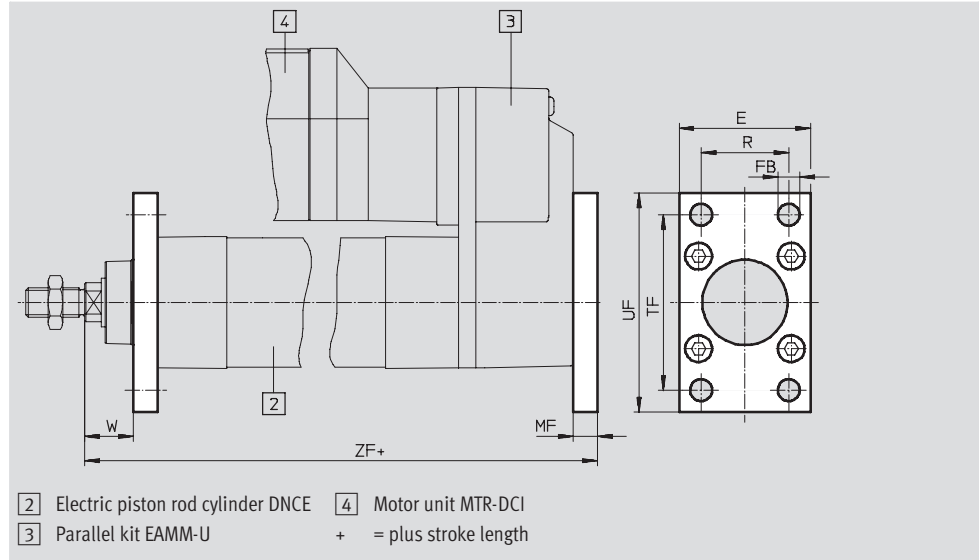

Dimensions and ordering data								
For size	E	FB	MF	R	TF	UF	W	ZF
[mm]		∅ H13						
32	45	7	10	32	64	80	16	198
40	54	9	10	36	72	90	20	233.5
63	75	9	12	50	100	120	25	284

For size	Basic version				High corrosion protection			
	CRC ¹⁾	Weight	Part No.	Type	CRC ¹⁾	Weight	Part No.	Type
[mm]		[g]				[g]		
32	2	240	174 376	FNC-32	4	240	161 846	CRFNG-32
40	2	280	174 377	FNC-40	4	300	161 847	CRFNG-40
63	2	690	174 379	FNC-63	4	710	161 849	CRFNG-63

1) Corrosion resistance class 2 to Festo standard 940 070
Components subject to moderate corrosion stress. Externally visible parts with primarily decorative surface requirements which are in direct contact with a normal industrial environment or media such as coolants or lubricating agents.
Corrosion resistance class 4 to Festo standard 940 070
Components requiring higher corrosion resistance. Parts used with aggressive media, e.g. food or chemical industry. These applications should be supported with special tests with the media if required

Electric cylinders DNCE, with piston rod

Accessories

FESTO

Trunnion flange ZNCF/CRZNG

Material:

ZNCF: Special steel casting
CRZNG: Electrolytically polished
special steel casting
Copper, PTFE and silicone-free

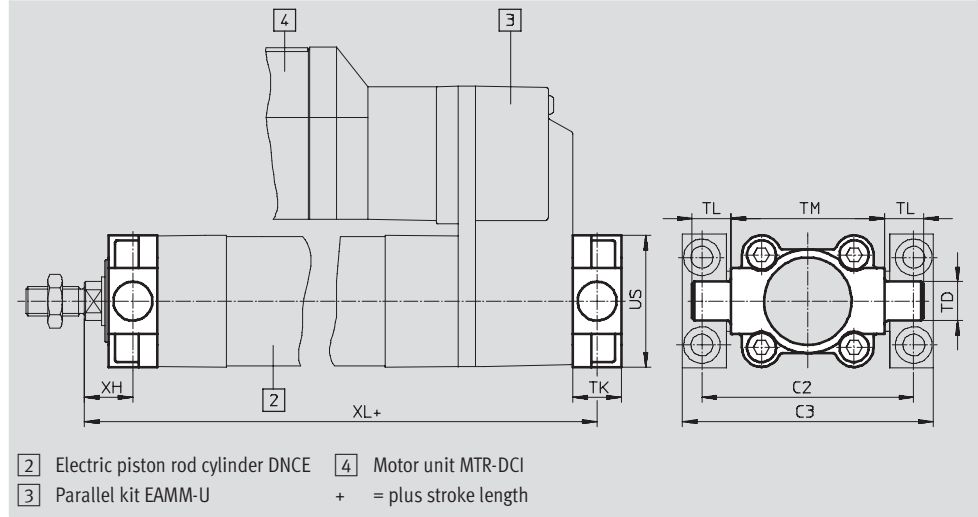

Dimensions and ordering data

For size	C2	C3	TD ∅ e9	TK	TL	TM	US	XH	XL
[mm]									
32	71	86	12	16	12	50	45	18	196
40	87	105	16	20	16	63	54	20	233.5
63	116	136	20	24	20	90	75	25	284

For size [mm]	Basic version				High corrosion protection			
	CRC ¹⁾	Weight [g]	Part No.	Type	CRC ¹⁾	Weight [g]	Part No.	Type
32	2	130	174 411	ZNCF-32	4	150	161 852	CRZNG-32
40	2	240	174 412	ZNCF-40	4	260	161 853	CRZNG-40
63	2	600	174 414	ZNCF-63	4	640	161 855	CRZNG-63

- 1) Corrosion resistance class 2 to Festo standard 940 070
Components subject to moderate corrosion stress. Externally visible parts with primarily decorative surface requirements which are in direct contact with a normal industrial environment or media such as coolants or lubricating agents.
Corrosion resistance class 4 to Festo standard 940 070
Components requiring higher corrosion resistance. Parts used with aggressive media, e.g. food or chemical industry. These applications should be supported with special tests with the media if required

Electric cylinders DNCE, with piston rod

Accessories

Trunnion support LNZG

Material:
Trunnion support:
Anodised aluminium
Plain bearing: Polymer
Copper, PTFE and silicone-free

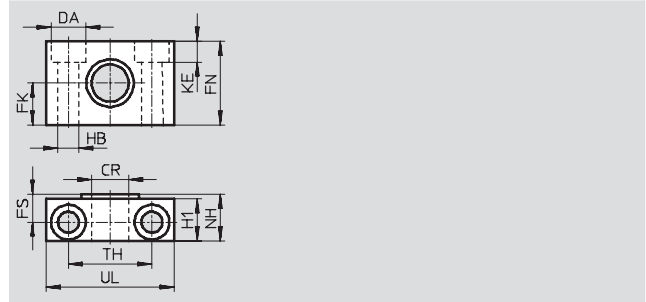

Dimensions and ordering data															
For size	CR	DA	FK	FN	FS	H1	HB	KE	NH	TH	UL	CRC ¹⁾	Weight	Part No.	Type
[mm]	∅ D11	∅ H13	∅ ±0.1				∅ H13			±0.2			[g]		
32	12	11	15	30	10.5	15	6.6	6.8	18	32	46	2	125	32 959	LNZG-32
40	16	15	18	36	12	18	9	9	21	36	55	2	400	32 960	LNZG-40/50
63	20	18	20	40	13	20	11	11	23	42	65	2	480	32 961	LNZG-63/80

Trunnion support CRLNZG

Material:
High-alloy steel
Copper, PTFE and silicone-free

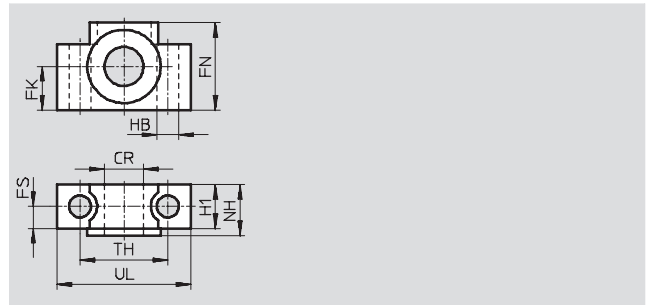
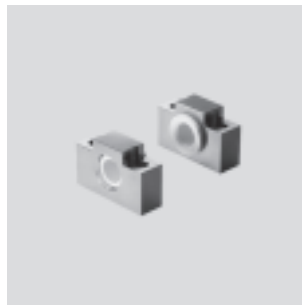

Dimensions and ordering data													
For size	CR	FK	FN	FS	H1	HB	NH	TH	UL	CRC ¹⁾	Weight	Part No.	Type
[mm]	∅ D11	∅ ±0.1				∅ H13		±0.2			[g]		
32	12	15	30	10.5	15	6.6	18	32	46	4	200	161 874	CRLNZG-32
40	16	18	36	12	18	9	21	36	55	4	330	161 875	CRLNZG-40/50
63	20	20	40	13	20	11	23	42	65	4	440	161 876	CRLNZG-63/80

1) Corrosion resistance class 2 to Festo standard 940 070
Components subject to moderate corrosion stress. Externally visible parts with primarily decorative surface requirements which are in direct contact with a normal industrial environment or media such as coolants or lubricating agents.
Corrosion resistance class 4 to Festo standard 940 070
Components requiring higher corrosion resistance. Parts used with aggressive media, e.g. food or chemical industry. These applications should be supported with special tests with the media if required

Electric cylinders DNCE, with piston rod

Accessories

FESTO

Swivel flange SNC

Material:

Die-cast aluminium

Copper, PTFE and silicone-free

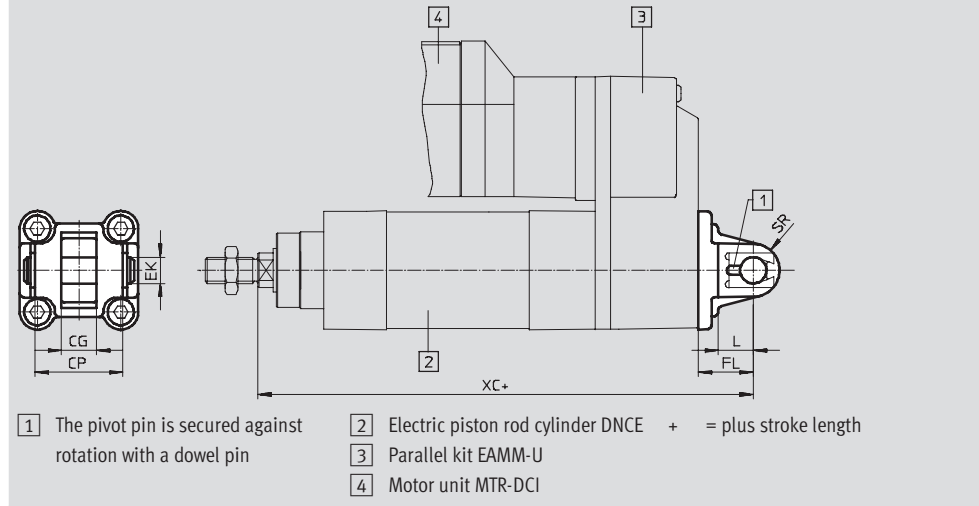

- 1 The pivot pin is secured against rotation with a dowel pin
- 2 Electric piston rod cylinder DNCE + = plus stroke length
- 3 Parallel kit EAMM-U
- 4 Motor unit MTR-DCI

Dimensions and ordering data

For size	CG	CP	EK ∅	FL	L	SR	XC	CRC ¹⁾	Weight	Part No.	Type
[mm]	H14	h14		±0.2					[g]		
32	14	34	10	22	13	10	210	2	90	174 383	SNC-32
40	16	40	12	25	16	12	248.5	2	120	174 384	SNC-40
63	21	51	16	32	21	16	304	2	320	174 386	SNC-63

Swivel flange SNCS

Material:

Die-cast aluminium

Copper, PTFE and silicone-free

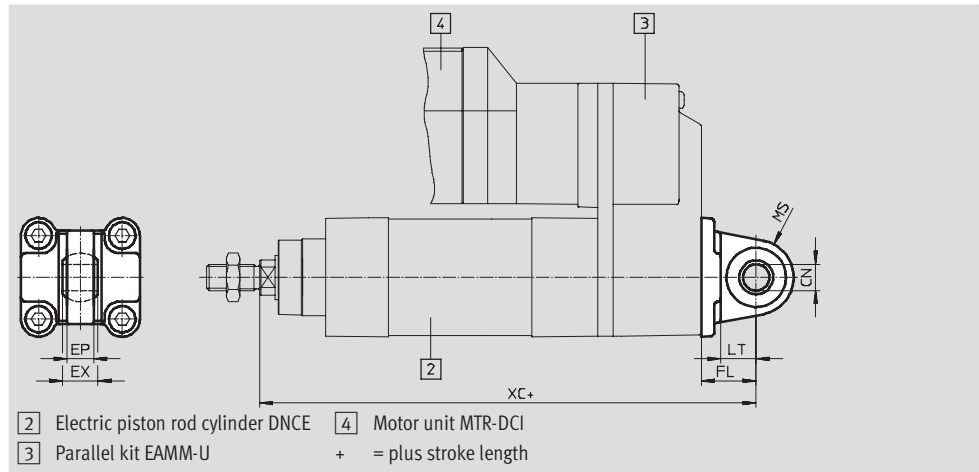
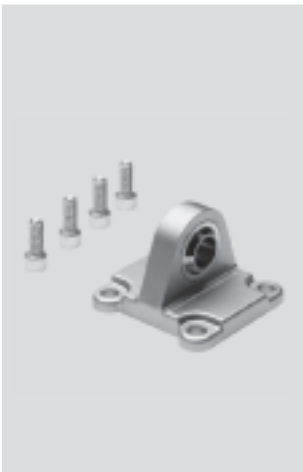

- 2 Electric piston rod cylinder DNCE
- 3 Parallel kit EAMM-U
- 4 Motor unit MTR-DCI + = plus stroke length

Dimensions and ordering data

For size	CN ∅	EP	EX	FL	LT	MS	XC	CRC ¹⁾	Weight	Part No.	Type
[mm]	H7	+0.2		±0.2					[g]		
32	10	10.5	14	22	13	15	210	2	85	174 397	SNCS-32
40	12	12	16	25	16	17	248.5	2	125	174 398	SNCS-40
63	16	15	21	32	21	22	304	2	280	174 400	SNCS-63

1) Corrosion resistance class 2 to Festo standard 940 070

Components subject to moderate corrosion stress. Externally visible parts with primarily decorative surface requirements which are in direct contact with a normal industrial environment or media such as coolants or lubricating agents

Electric cylinders DNCE, with piston rod

Accessories

FESTO

Swivel flange
SNCB/SNCB-...-R3

Material:
SNCB: Die-cast aluminium
SNCB-...-R3: Die-cast aluminium with protective coating, high corrosion protection
Copper, PTFE and silicone-free

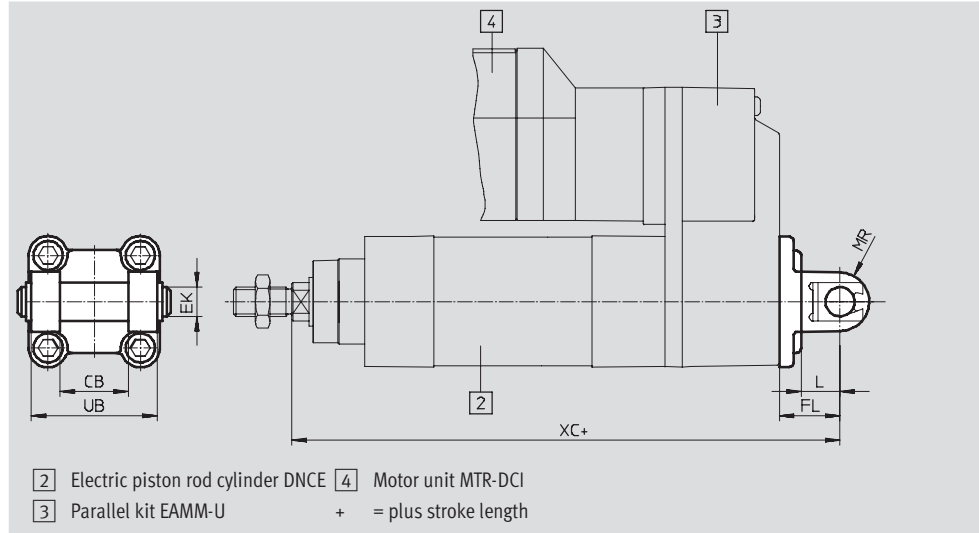

Dimensions and ordering data							
For size	CB	EK	FL	L	MR	UB	XC
[mm]	H14	∅ e8	±0.2			h14	
32	26	10	22	13	10	45	210
40	28	12	25	16	12	52	248.5
63	40	16	32	21	16	70	304

For size	Basic version				Variant R3 – High corrosion protection			
	CRC ¹⁾	Weight [g]	Part No.	Type	CRC ¹⁾	Weight [g]	Part No.	Type
32	2	100	174 390	SNCB-32	3	100	176 944	SNCB-32-R3
40	2	150	174 391	SNCB-40	3	150	176 945	SNCB-40-R3
63	2	365	174 393	SNCB-63	3	365	176 947	SNCB-63-R3

1) Corrosion resistance class 3 to Festo standard 940 070
Components requiring higher corrosion resistance. External visible parts in direct contact with industrial atmospheres or media such as solvents and cleaning agents, with a predominantly functional requirement for the surface

Electric cylinders DNCE, with piston rod

Accessories

Trunnion mounting kit ZNCM

Material:
Tempered steel

The mounting kit can be attached at any position on the cylinder profile barrel.

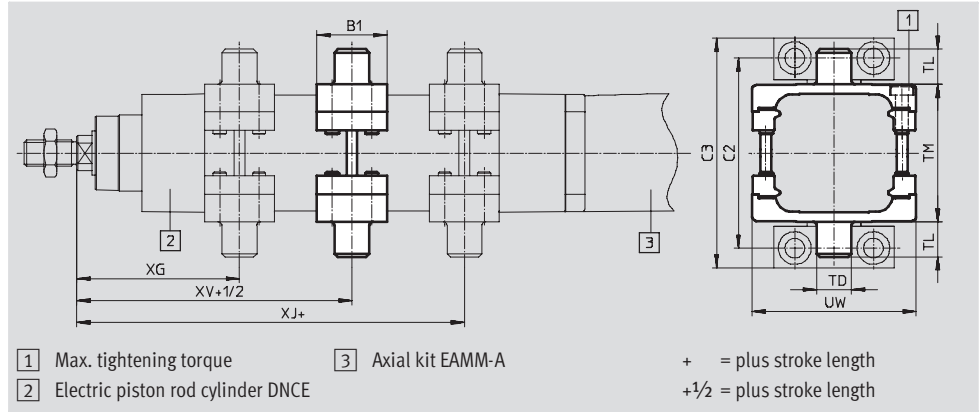

In combination with the parallel kit EAMM-U, the trunnion mounting kit cannot be mounted in the vicinity of the motor.



Dimensions and ordering data								
For size	B1	C2	C3	TD ∅ e9	TL	TM	UW	XG
[mm]								
32	30	71	86	12	12	50	65	65
40	32	87	105	16	16	63	75	74.5
63	41	116	136	20	20	90	105	91.5

For size	XJ	XV	Max. tightening torque [Nm]	CRC ¹⁾	Weight [g]	Part No.	Type
[mm]							
32	107	86	4+1	2	210	163 525	ZNCM-32
40	130.5	102.5	8+1	2	385	163 526	ZNCM-40
63	157.5	124.5	18+2	2	890	163 528	ZNCM-63

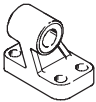
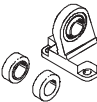
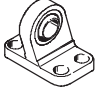
1) Corrosion resistance class 2 to Festo standard 940 070
Components subject to moderate corrosion stress. Externally visible parts with primarily decorative surface requirements which are in direct contact with a normal industrial environment or media such as coolants or lubricating agents

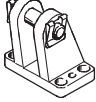
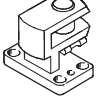



Ordering data – Mounting attachments				Technical data → Internet: clevis foot			
Designation	For size	Part No.	Type	Designation	For size	Part No.	Type
Clevis foot LNG				Clevis foot LSN			
	32	33 890	LNG-32		32	5 561	LSN-32
	40	33 891	LNG-40		40	5 562	LSN-40
	63	33 893	LNG-63		63	5 564	LSN-63
Clevis foot LSNG				Clevis foot LSNSG			
	32	31 740	LSNG-32		32	31 747	LSNSG-32
	40	31 741	LSNG-40		40	31 748	LSNSG-40
	63	31 743	LSNG-63		63	31 750	LSNSG-63
Clevis foot LBG				Right-angle clevis foot LQG			
	32	31 761	LBG-32		32	31 768	LQG-32
	40	31 762	LBG-40		40	31 769	LQG-40
	63	31 764	LBG-63		63	31 771	LQG-63

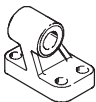

Electric cylinders DNCE, with piston rod

Accessories

FESTO

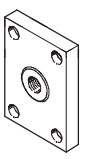
Ordering data – Mounting attachments, corrosion resistant			Technical data → Internet: clevis foot	
Designation	For size	Part No.	Type	
Clevis foot CRLNG				
	32	161 840	CRLNG-32	
	40	161 841	CRLNG-40	
	63	161 843	CRLNG-63	

Ordering data – Piston-rod attachments				Technical data → Internet: piston-rod attachment			
Designation	For size	Part No.	Type	Designation	For size	Part No.	Type
Rod eye SGS				Rod clevis SGA			
	32	9 261	SGS-M10x1,25		32	32 954	SGA-M10x1,25
	40	9 262	SGS-M12x1,25		40	10 767	SGA-M12x1,25
	63	9 263	SGS-M16x1,5		63	10 768	SGA-M16x1,5
Rod clevis SG				Self-aligning rod coupler FK			
	32	6 144	SG-M10x1,25		32	6 140	FK-M10x1,25
	40	6 145	SG-M12x1,25		40	6 141	FK-M12x1,25
	63	6 146	SG-M16x1,5		63	6 142	FK-M16x1,5
Coupling piece KSZ							
	32	36 125	KSZ-M10x1,25				
	40	36 126	KSZ-M12x1,25				
	63	36 127	KSZ-M16x1,5				

Ordering data – Piston rod attachments, corrosion resistant				Technical data → Internet: piston-rod attachment			
Designation	For size	Part No.	Type	Designation	For size	Part No.	Type
Rod eye CRSGS				Rod clevis CRSG			
	32	195 582	CRSGS-M10x1,25		32	13 569	CRSG-M10x1,25
	40	195 583	CRSGS-M12x1,25		40	13 570	CRSG-M12x1,25
	63	195 584	CRSGS-M16x1,5		63	13 571	CRSG-M16x1,5

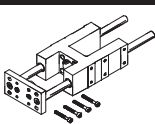
Ordering data – Guide units for fixed strokes (recirculating ball bearing guide only)				Technical data → Internet: feng			
	Stroke [mm]	Part No.	Type	Stroke [mm]	Part No.	Type	
	For size 32			For size 40			
	10 ... 100	34 494	FENG-32-100-KF	10 ... 100	34 500	FENG-40-100-KF	
	10 ... 200	34 496	FENG-32-200-KF	10 ... 200	34 502	FENG-40-200-KF	
	10 ... 320	34 497	FENG-32-320-KF	10 ... 320	34 504	FENG-40-320-KF	
	10 ... 400	150 290	FENG-32-400-KF	10 ... 400	150 291	FENG-40-400-KF	
	10 ... 500	34 498	FENG-32-500-KF	10 ... 500	34 505	FENG-40-500-KF	
	For size 63						
	10 ... 100	34 514	FENG-63-100-KF				
	10 ... 200	34 516	FENG-63-200-KF				
	10 ... 320	34 518	FENG-63-320-KF				
	10 ... 400	34 519	FENG-63-400-KF				
	10 ... 500	34 520	FENG-63-500-KF				

Electric cylinders DNCE, with piston rod

Accessories

FESTO

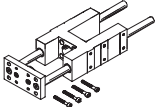

Ordering data – Guide units for variable strokes					Technical data → Internet: feng	
	For size [mm]	Stroke [mm]	With recirculating ball bearing guide		With plain-bearing guide	
			Part No.	Type	Part No.	Type
	32	10 ... 500	34 487	FENG-32-...-KF	34 481	FENG-32-...
	40	10 ... 500	34 488	FENG-40-...-KF	34 482	FENG-40-...
	63	10 ... 500	34 490	FENG-63-...-KF	34 484	FENG-63-...

Permissible proximity sensors in combination with motor units MTR-DCI

Ordering data – Proximity sensor for T-slot, magneto-resistive						Technical data → Internet: smt	
	Type of mounting	Switch output	Electrical connection	Cable length [m]	Part No.	Type	
	N/O contact						
	Insertable in the slot lengthwise, flush with the cylinder profile	PNP	Plug M8x1, 3-pin	0.3	175 484	SMT-8-PS-S-LED-24-B	

Permissible proximity sensors in combination with servo motors MTR-AC, stepper motors MTR-ST or guide units FENG

Ordering data – Proximity sensor for T-slot, magneto-resistive						Technical data → Internet: smt	
	Type of mounting	Switch output	Electrical connection	Cable length [m]	Part No.	Type	
	N/O contact						
	Insertable in the slot lengthwise, flush with the cylinder profile	PNP	Cable, 3-wire	2.5	175 436	SMT-8-PS-K-LED-24-B	

Ordering data – Proximity sensors for T-slot, magnetic reed						Technical data → Internet: sme	
	Type of mounting	Switch output	Electrical connection	Cable length [m]	Part No.	Type	
	N/O contact						
	Insertable in the slot from above, flush with cylinder profile	Contacting	Cable, 3-wire	2.5	543 862	SME-8M-DS-24V-K-2,5-OE	
				5.0	543 863	SME-8M-DS-24V-K-5,0-OE	
	Insertable in the slot lengthwise, flush with the cylinder profile	Contacting	Cable, 3-wire	2.5	150 855	SME-8-K-LED-24	

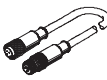
Ordering data – Connecting cables					Technical data → Internet: km8	
	Mounting	Connection	Cable length [m]	Part No.	Type	
	Straight socket					
	Union nut M8, both ends	3-pin	0.5	175 488	KM8-M8-GSGD-0,5	
			1	175 489	KM8-M8-GSGD-1	
			2.5	165 610	KM8-M8-GSGD-2,5	
			5	165 611	KM8-M8-GSGD-5	

Ordering data – Slot cover for T-slot				
	Mounting	Length	Part No.	Type
		Insertable from above	2x 0.5 m	151 680