

Cantilever axes DGEA, with toothed belt drive



Cantilever axes DGEA, with toothed belt drive

Features

FESTO

Key features at a glance

- Super flat Ω drive head enabling high mechanical torques.
- Improved dynamics compared to toothed belt axis DGE-ZR in cantilever operation, as the motor, gear unit and drive head are securely mounted and thus the moving load (profile barrel) is considerably reduced.
- Tried and tested motor-controller packages can be utilised.
- Mounting options adapted to the new multi-axis modular system.



- High-quality guide as for DGE-KF/DGP-KF axis.

Size		18	25	40
Max. working stroke	[mm]	800	900	1000
Max. working load	[kg]	7	18	27
Max. speed	[m/s]	3	3	3
Max. feed force	[N]	230	400	1000

Variants

Basic design

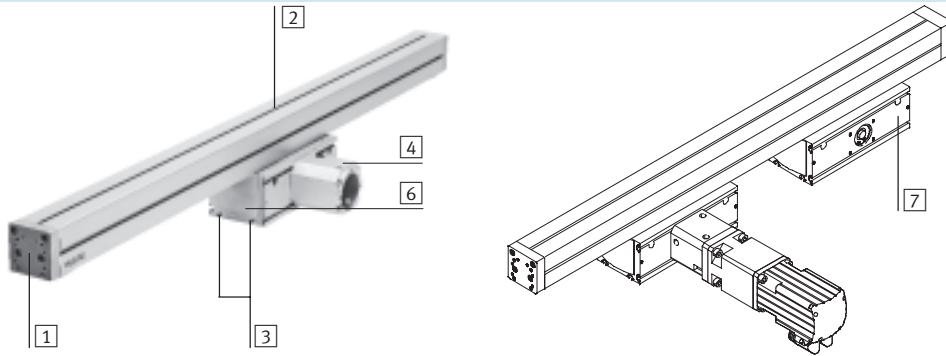

- 1 Mounting interface for working load: thread, centring holes and hole pattern are identical to the end caps on the DGE axes. Both caps can be machined as desired or removed and replaced by others.

- 2 Profile barrel: 3 sides with slots for external mounting – clearance for tubing and electrical cable throughfeed

- 3 Mounting interface for cantilever application (matched to DGE-...-KF slide)

- 4 Coupling housing

- 5 Coupling housing with integrated angled gear unit

- 6 Drive head

- 7 Optional: Additional drive head without drive shaft for increasing mechanical torque resistance

With angled gear unit

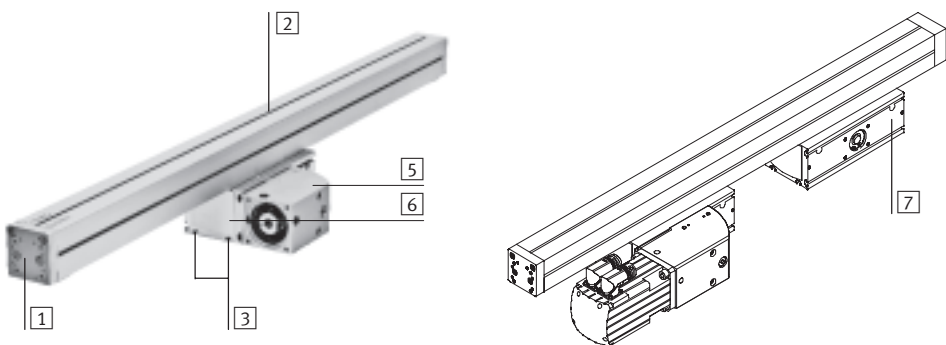

Cantilever axes DGEA, with toothed belt drive

Features

System selection for electromechanical drives

Cantilever axis



 Note

For the cantilever axes and the motors there are matching complete solutions.

Motor kit

→ 22

Axial kit



Axial kit consisting of:

- Motor flange
- Coupling housing
- Coupling
- Screws

Motor

→ 22



- 1 Servo motor EMMS-AS
- 2 Stepper motor EMMS-ST

Motor controller

Technical data → Internet: motor controller



- 1 Servo motor controller CMMP-AS, CMMS-AS
- 2 Stepper motor controller CMMS-ST

Cantilever axes DGEA, with toothed belt drive

System example

System product for handling and assembly technology

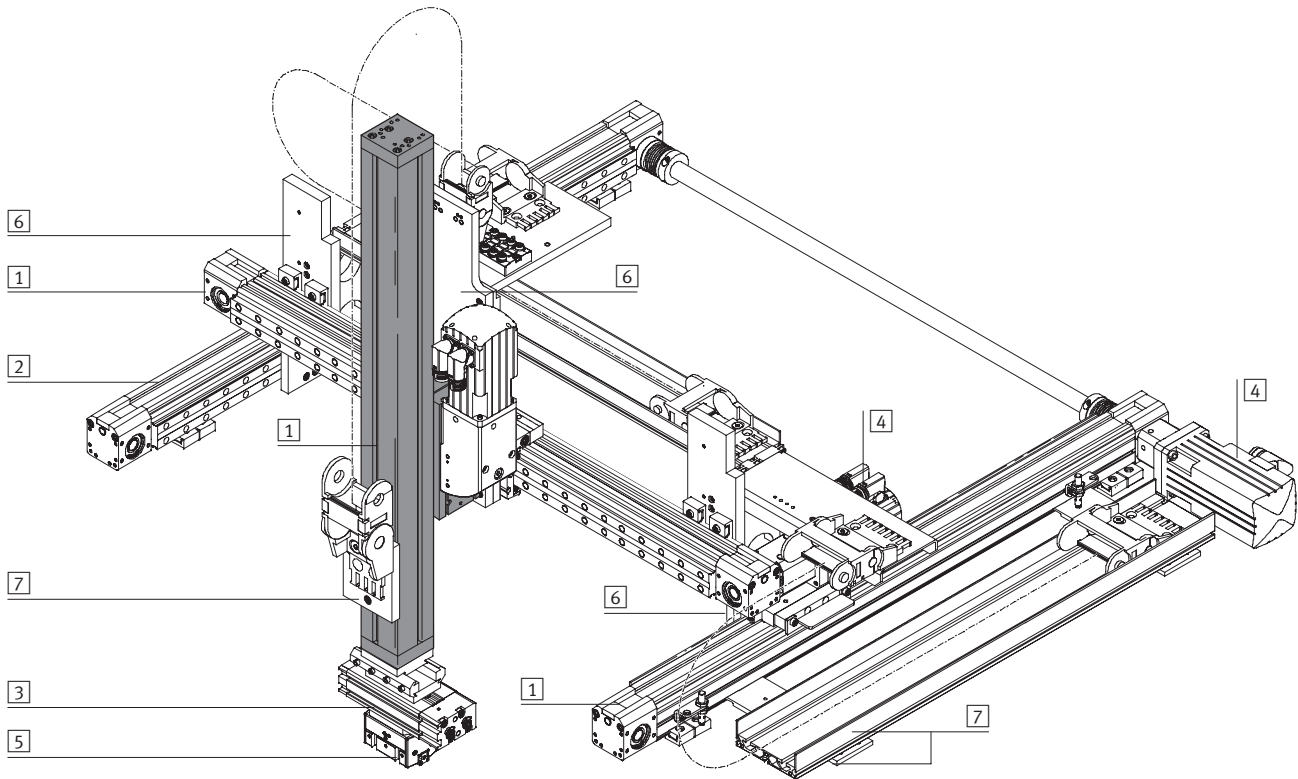

System elements and accessories		
	Brief description	→ Page/Internet
1	Axes	Wide range of combination options within handling and assembly technology axes
2	Passive guide axis	To increase force and torque capacity in multi-axis applications guide axes
3	Drive units	Wide range of combination options within handling and assembly technology drive
4	Motors	Servo and stepper motors, with or without gearing motor
5	Grippers	Wide range of variation options within handling and assembly technology gripper
6	Adapters	For drive/drive and drive/gripper combinations adapter kit
7	Installation components	For achieving a clear-cut, safe layout for electrical cables and tubing installation component

Cantilever axes DGEA, with toothed belt drive

Type codes

DGEA - 25 - 500 - ZR - WH - ZWK -

Type

DGEA	Cantilever axis
------	-----------------

Size

Stroke [mm]

Drive function

ZR	Toothed belt
----	--------------

Drive head

WH	Drive shaft at rear
WV	Drive shaft at front
WB	Drive shaft at both ends
GVL	Integrated angled gear unit/motor at front left
GVR	Integrated angled gear unit/motor at front right
GHL	Integrated angled gear unit/motor at rear left
GHR	Integrated angled gear unit/motor at rear right

Additional drive head

ZWK	Without drive shaft
-----	---------------------

Accessories supplied separately

...S	Slot cover for profile slot
...B	Slot cover for drive head
...Y	Slot nut for profile slot
...X	Slot nut for drive head
...C	Shock absorber with retainer
...Z	Centring sleeve
L	Mounting kit for proximity sensor
...O	Proximity sensor with cable (normally open contact)
...P	Proximity sensor with cable (normally closed contact)
...W	Proximity sensor with plug (normally open contact)
...R	Proximity sensor with plug (normally closed contact)
...V	Cable with socket, 2.5 m

Cantilever axes DGEA, with toothed belt drive

Peripherals overview

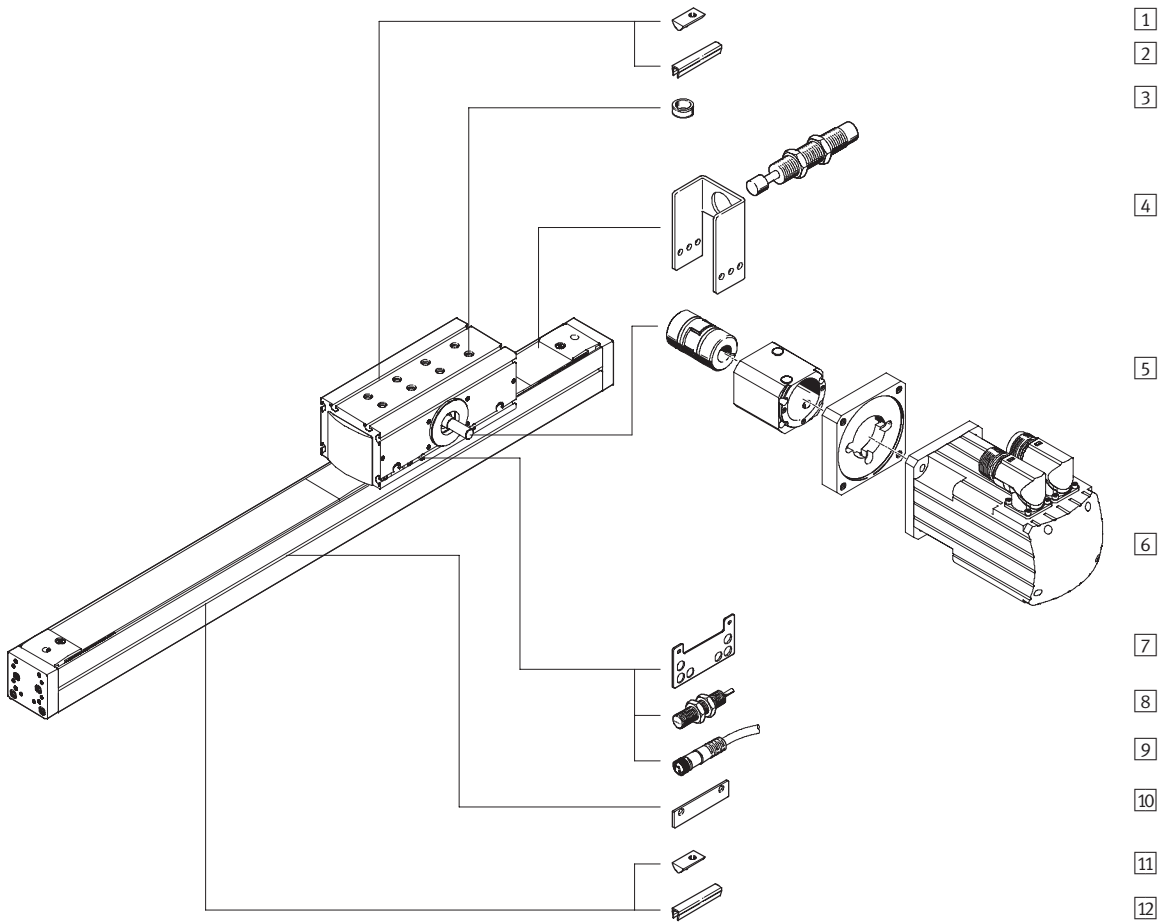

With angled gear unit

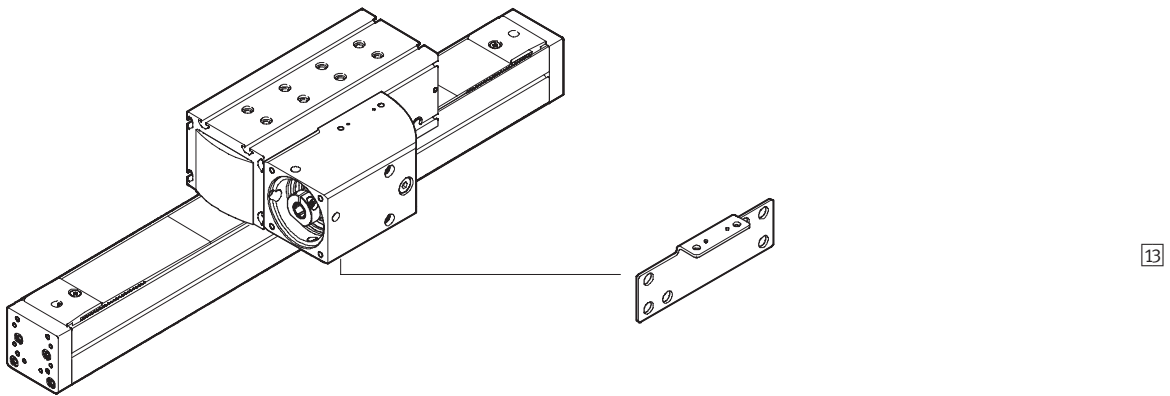

Cantilever axes DGEA, with toothed belt drive

Peripherals overview

Variants and accessories				
Type	Brief description	Basic design	Angled gear unit	→ Page/Internet
1 Slot nut for drive head X	For mounting the axis	■	■	28
2 Slot cover for drive head B	For protecting against ingress of dirt	■	■	28
3 Centring sleeve Z	To centre the axis	■	■	28
4 Shock absorber with retainer C	Prevents damage to the axis in the event of a power failure (in vertical operation), if the axis is driven into the end position by the load	■	■	27
5 Axial kit EAMM-A	For axial motor attachment (consisting of: coupling housing, clamping component, motor flange)	■	-	22
5 Coupling housing KG	Adapter for mounting the motor on the axis	■	integrated	22
5 Coupling KSE	Connecting element between axis and motor	■	integrated	22
5 Motor flange EAMF	Connecting element between coupling housing and motor	■	integrated	22
6 Motor EMMS	Motors specially matched to the axis, with or without gearing	■	■	22
7 Mounting plate L	Adapter for mounting the SIEN proximity sensor on the axis (basic design)	■	-	25
8 Proximity sensor O/P/W/R	For providing a proximity signal or safety check	■	■	28
9 Cable with socket V	Via proximity sensor	■	■	28
10 Switching lug L	For sensing the slide position	■	■	25
11 Slot nut for profile slot Y	For mounting attachments	■	■	28
12 Slot cover for profile slot S	For protecting against ingress of dirt	■	■	28
13 Mounting plate L	Adapter for mounting the SIEN proximity sensor on the axis with angled gear unit	-	■	26



Cantilever axes DGEA, with toothed belt drive

FESTO

Technical data

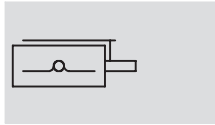
Function



-  Size
18, 25, 40
-  Stroke length
100 ... 1000 mm



General technical data				
Size		18	25	40
Constructional design		Cantilever axis with toothed belt drive		
Guide		Recirculating ball bearing guide		
Mounting position		Any		
Max. working stroke ¹⁾	[mm]	1 ... 800	1 ... 900	1 ... 1000
Max. working (effective) load, horizontal ²⁾	[kg]	6	15	40
Max. working load, vertical	[kg]	10	20	50
Max. feed force F_x	[N]	230	400	1000
Max. speed	[m/s]	3		
Max. acceleration	[m/s ²]	50		
Repetition accuracy	[mm]	< ±0.05		
Basic design				
Max. driving torque	[Nm]	3	5.2	19
Max. no-load driving torque ³⁾	[Nm]	0.4	0.4	1
Maximum drive speed	[rpm]	2222	2222	1500
With angled gear unit				
Max. driving torque	[Nm]	1.4	2.2	7.3
Max. no-load driving torque ³⁾	[Nm]	0.3	0.6	1.3
Maximum drive speed	[rpm]	6666	6666	4500
Gearing type		Crown gear unit		
Gearing		Straight		
Gear ratio		3		

1) Total stroke = working stroke + 2x stroke reserve

2) At 500 mm stroke and with a centred working load in the middle of the guide. Further values → 12

3) Measured at a speed of 0.2m/s

Operating and environmental conditions				
Size		18	25	40
Ambient temperature	[°C]	-10 ... +60		
Protection class		IP20		

Cantilever axes DGEA, with toothed belt drive

Technical data

Weights [kg]							
Size		18		25		40	
Number of drive heads		1	2	1	2	1	2
Basic design							
Overall weight	at 0 mm stroke ¹⁾	2.8	4.7	4.9	8.5	14.3	23.2
	Additional weight Per 100 mm stroke ¹⁾	0.35	0.35	0.47	0.47	1	1
Moving load	at 0 mm stroke	1.5	2	2.4	3.3	6.2	8.6
With angled gear unit							
Overall weight	at 0 mm stroke ¹⁾	3.6	5	6.6	9.3	19.5	26
	Additional weight Per 100 mm stroke ¹⁾	0.35	0.35	0.47	0.47	1	1
Moving load	at 0 mm stroke ¹⁾	1.5	2	2.4	3.3	6.2	8.6

1) Without motor, coupling, coupling housing and accessories

Mass moment of inertia							
Size		18		25		40	
Number of drive heads		1	2	1	2	1	2
J_0	[kg cm ²]	2.87	4.08	4.45	6.40	28	41.5
J_H	per metre stroke [kg cm ² /m]	6		8		36.5	
J_L	per kg working load [kg cm ² /kg]	1.66		1.66		3.65	
J_G	angled gear unit [kg cm ² /m]	0.14		0.26		2.02	
i	gear ratio	3		3		3	

The mass moment of inertia J_A of the entire axis is calculated as follows:

Basic design

$$J_A = J_0 + J_H \times \text{working stroke [m]} + J_L \times m_{\text{working load [kg]}}$$

With angled gear unit

$$J_A = J_G + \frac{J_0 + J_H \times \text{working stroke [m]} + J_L \times m_{\text{working load [kg]}}}{i^2}$$

Toothed belt				
Size		18	25	40
Expansion ¹⁾	[%]	0.037	0.053	0.056
Pitch	[mm]	3	3	5
Effective radius; effective diameter	[mm]	25.78	25.78	38.2
Feed constant	[mm/rev.]	81	81	120
Feed constant with integrated angled gear unit	[mm/rev.]	27	27	40

1) At max. feed force

Cantilever axes DGEA, with toothed belt drive

Technical data

Materials

Sectional view

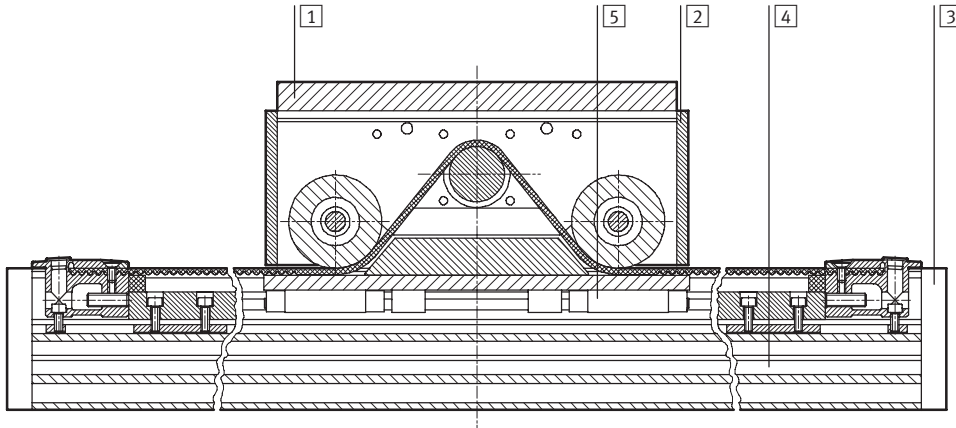

Axis	
1	Drive head interface
2	Drive head - Housing
3	End cap
4	Profile
5	Guide rail
-	Gearing housing
-	Pinion
-	Crown gear

Stroke reserve

- L2 Drive head in the end position of the working stroke
- L8 Distance between mechanical stop and external dimension of the axis
- L9 The stroke reserve is a safety distance available on both sides of the axis in addition to the stroke

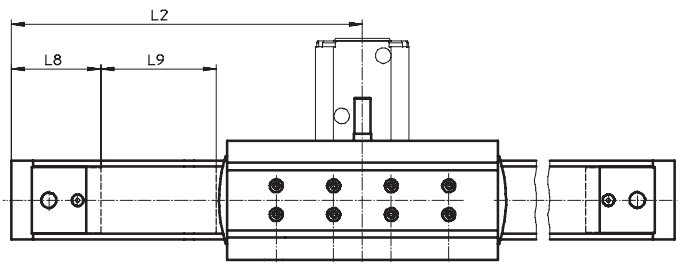

Example:
Type DGEA-25-500-ZR

Working stroke = 500 mm
 Stroke reserve = (2x 81 mm)
 = 162 mm
 Total stroke = 500 mm + 126 mm
 = 662 mm

Size		18	25	40
L9 per end position	[mm]	81	81	120

Cantilever axes DGEA, with toothed belt drive

Technical data

Characteristic load values of the guide

The indicated forces and torques refer to the centre of the guide rail. They must not be exceeded in the dynamic range. Special attention must be paid to the cushioning phase.

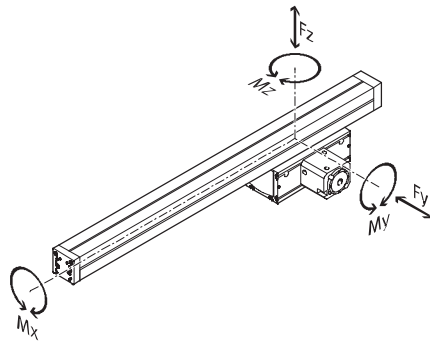

If the cantilever axis is simultaneously subjected to several of the forces and torques listed below, the following equation must be satisfied in addition to the indicated maximum loads.

$$\left| \frac{F_y}{F_{y_{max.}}} \right| + \left| \frac{F_z}{F_{z_{max.}}} \right| + \left| \frac{M_x}{M_{x_{max.}}} \right| + \left| \frac{M_y}{M_{y_{max.}}} \right| + \left| \frac{M_z}{M_{z_{max.}}} \right| \leq 1$$

Permissible forces and torques				
Size		18	25	40
F _{y_{max.}}	[N]	2000	3080	7300
F _{z_{max.}}	[N]	2000	3080	7300
M _{x_{max.}}	[Nm]	19	28	133
M _{y_{max.}}	[Nm]	94	230	665
M _{z_{max.}}	[Nm]	65	160	460

Characteristic load values of the interface for mounting the effective load

The forces and torques specified refer to the interface for mounting the effective load. They must not be exceeded in the dynamic range. Special attention must be paid to the cushioning phase.

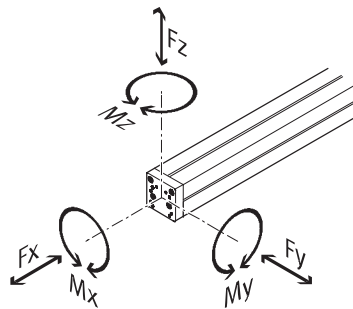

If the cantilever axis is simultaneously subjected to several of the forces and torques listed below, the following equation must be satisfied in addition to the indicated maximum loads.

$$\left| \frac{F_x}{F_{x_{max.}}} \right| + \left| \frac{F_y}{F_{y_{max.}}} \right| + \left| \frac{F_z}{F_{z_{max.}}} \right| + \left| \frac{M_x}{M_{x_{max.}}} \right| + \left| \frac{M_y}{M_{y_{max.}}} \right| + \left| \frac{M_z}{M_{z_{max.}}} \right| \leq 1$$

Permissible forces and torques				
Size		18	25	40
F _{x_{max.}}	[N]	6000	6000	8400
F _{y_{max.}}	[N]	2240	2240	3200
F _{z_{max.}}	[N]	2240	2240	3200
M _{x_{max.}}	[Nm]	30	50	118
M _{y_{max.}}	[Nm]	125	230	407
M _{z_{max.}}	[Nm]	185	273	580

- Note

Sizing software
PositioningDrives
→ www.festo.com

Cantilever axes DGEA, with toothed belt drive

Technical data

2nd moment of area¹⁾

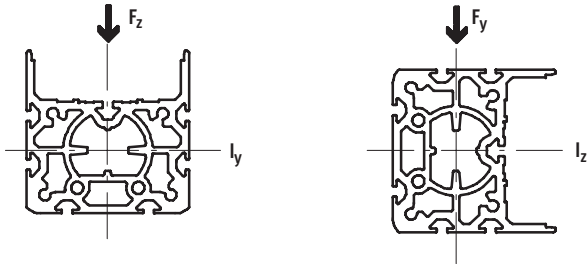

Size		18	25	40
ly	[mm ⁴]	173x10 ³	432x10 ³	1759x10 ³
lz	[mm ⁴]	135x10 ³	438x10 ³	1894x10 ³

1) After machining or replacing the end cap, the values become invalid.

Deflection f of the profile as a function of the distance L and the effective load m

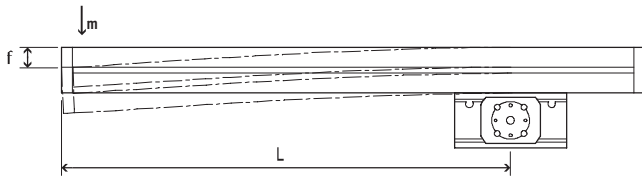

DGEA-18

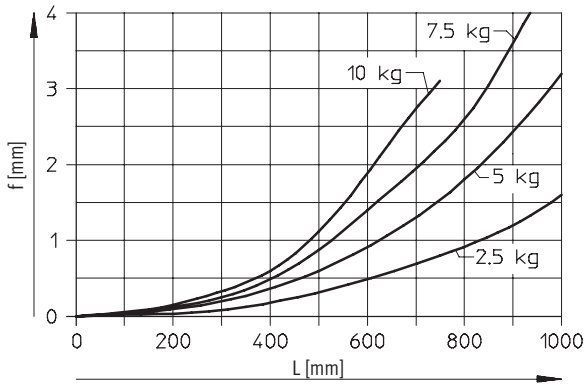

DGEA-25

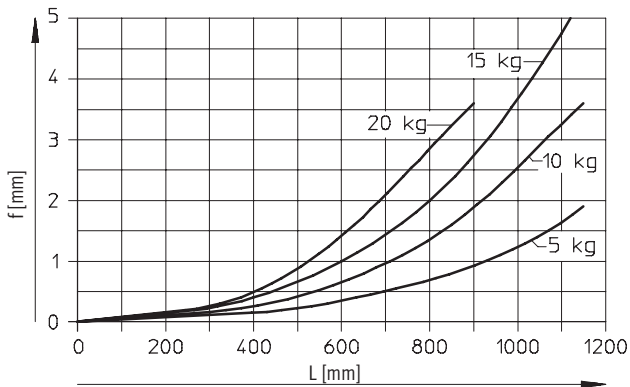

Cantilever axes DGEA, with toothed belt drive

Technical data

Deflection f of the profile as a function of the distance L and the effective load m

DGEA-40

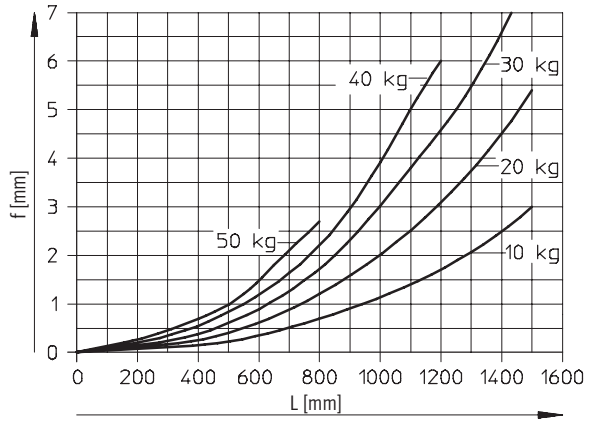

Cantilever axes DGEA, with toothed belt drive

Technical data

Dimensions Download CAD data → www.festo.com

Basic design

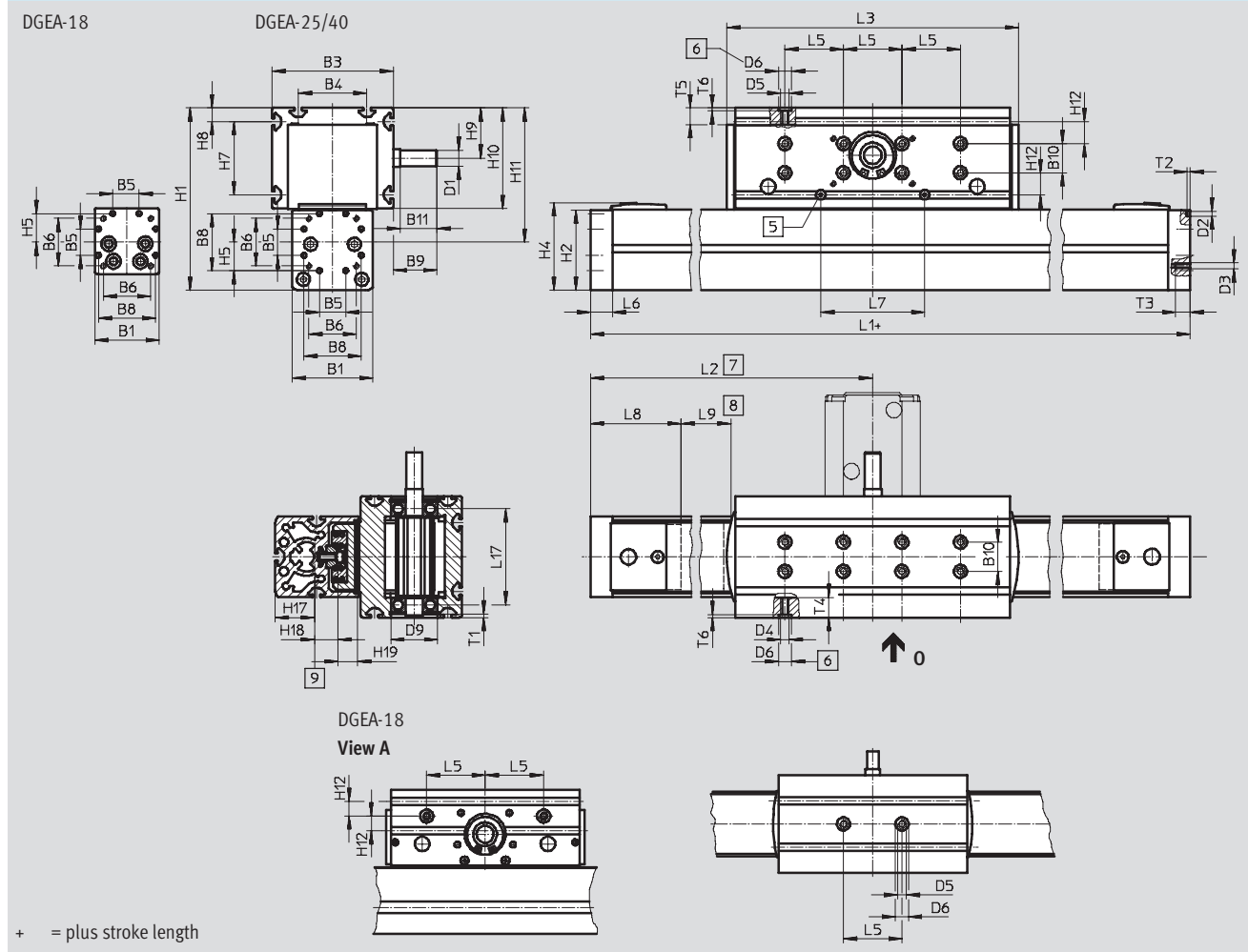

Coupling housing

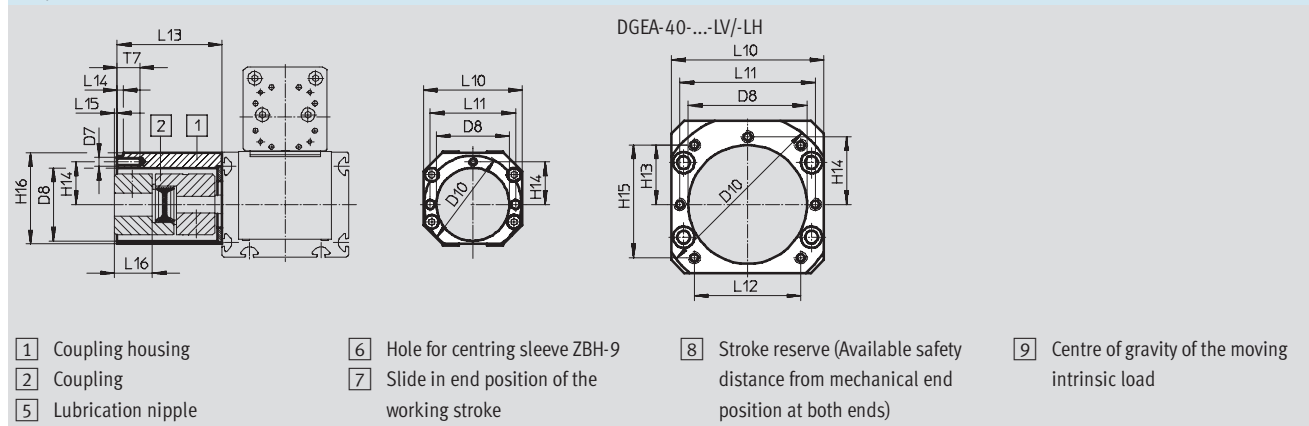

Cantilever axes DGEA, with toothed belt drive

Technical data

Size	Variant	B1	B3	B4	B5 ±0.1	B6	B8	B9	B10	B11	D1 ∅ h6	D2 ∅	D3
18	KV/KH	44	67	32	18	32.5	39.1	16	–	12	8	3.3	M4
25	KV/KH	55	83	47	18	32.5	39.1	29.8	20	25	11	3.3	M4
40	KV/KH	80	111.8	72	28	49	53	30.1	40	25	15	4	M5
	LV/LH												

Size	Variant	D4	D5	D6 ∅ H7	D7	D8 ∅	D9 ∅ H7	D10 ∅ g7	H1	H2	H4	H5	H7
18	KV/KH	M6	M6	9	M4	32	28	44	99	45	50.8	19.55	20
25	KV/KH	M6	M6	9	M6	48	32	64	128	57.7	63.1	19.55	50
40	KV/KH	M6	M6	9	M6	48	40	64	197	85	91.3	26.5	72
	LV/LH				M8	78		118					

Size	Variant	H8	H9	H10	H11	H12	H13	H14 ±0.1	H15	H16	H17	H18	H19
18	KV/KH	8	30.5	52	77	10	–	19	–	45	19.6	10	14.3
25	KV/KH	9.5	32.5	69	95	15	–	28	–	60	27.1	16	13.3
40	KV/KH	15.5	55.5	110	153	16	–	28	–	60	42.8	21.5	18
	LV/LH						39	44.5	74	100			

Size	Variant	L1	L2	L3	L5	L6	L7	L8	L9	L10	L11	L12	L13
18	KV/KH	419.5	210	138	40	13	28	58	81	45	38	–	40
25	KV/KH	487.5	244	202	40	15	71	60	81	65	56	–	65
40	KV/KH	662	331	256	40	15	94	81	120	65	56	–	65
	LV/LH									100	89	70	96

Size	Variant	L14	L15	L16	L17	T1	T2	T3	T4 min.	T5 min.	T6	T7
18	KV/KH	3.2	–3.6	14.6	53	1.6	2	9	11	11	2.1	10
25	KV/KH	4	2.2	22.8	65.6	2.3	2	10	11	11	2.1	13
40	KV/KH	4	2.2	22.8	90	2.8	3	10	11	11	2.1	13
	LV/LH	5	–0.9	35.9								18

Cantilever axes DGEA, with toothed belt drive

Technical data

Dimensions Download CAD data → www.festo.com

With angled gear unit

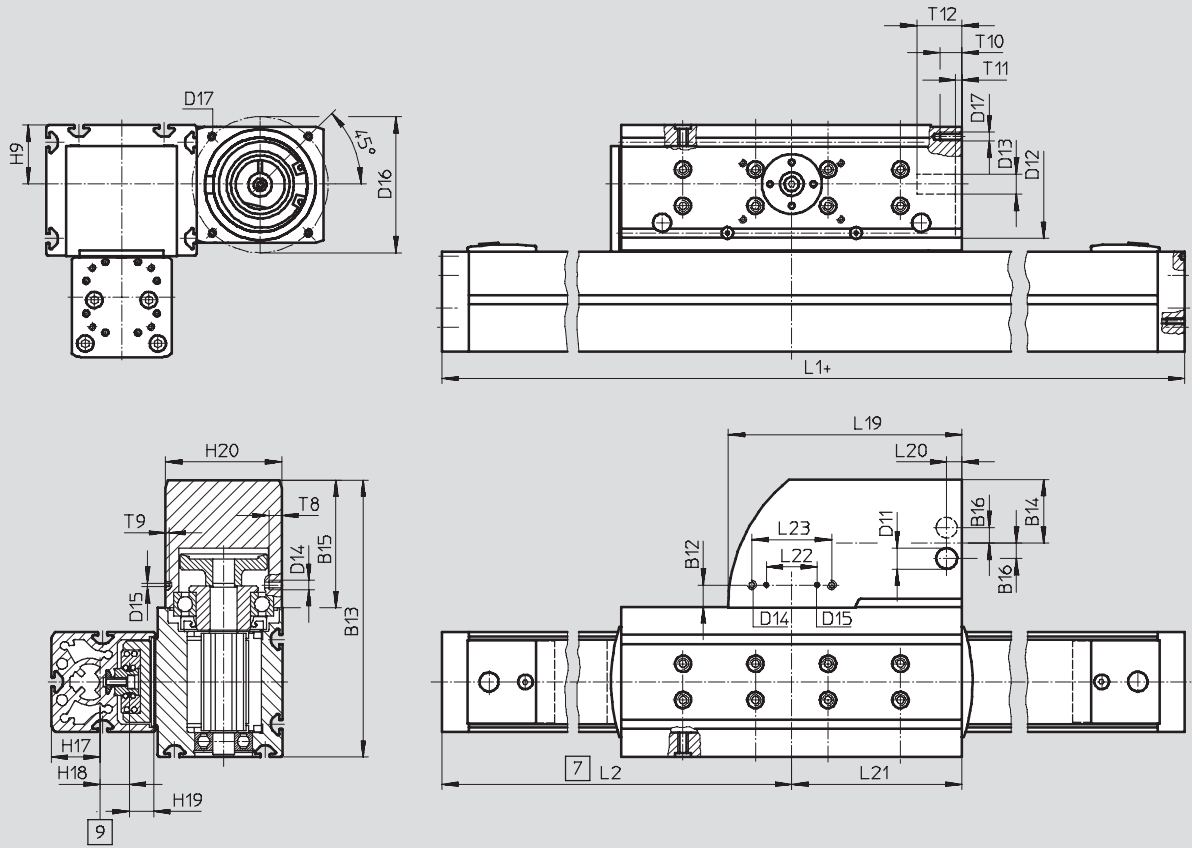

+ = plus stroke length
 [9] Slide in end position of the nominal stroke
 [9] Centre of gravity of the moving intrinsic load

Size	B12	B13	B14	B15	B16	D11 ∅	D12 ∅ +0.05/+0.08	D13 ∅	D14	D15 ∅ ±0.05
18	11	122	27.5	55	9	11.5	40	9	M4	2
25	12	153	35	70	9	11.5	60	11	M5	2
40	16	211.8	50	100	17	11.9	95	19	M5	3

Size	D16 ∅	D17	H9	H17	H18	H19	H20	L1	L2	L19
18	63	M5	30.5	19.6	10	14.3	55	419.5	210	97
25	75	M5	32.5	27.1	16	13.3	64	487.5	244	129
40	115	M8	55.5	42.8	21.5	18	100	662	331	173

Size	L20	L21	L22	L23	T8	T9	T10	T11	T12
			±0.1	±0.1					
18	8.5	64.5	18	34	5	2	12	3.5	24
25	8.5	94	28	44	7	2	12	3.5	25
40	11.5	120	44	68	5	2	12	3.5	40

Cantilever axes DGEA, with toothed belt drive

Technical data

Dimensions

Download CAD data → www.festo.com

with additional drive head

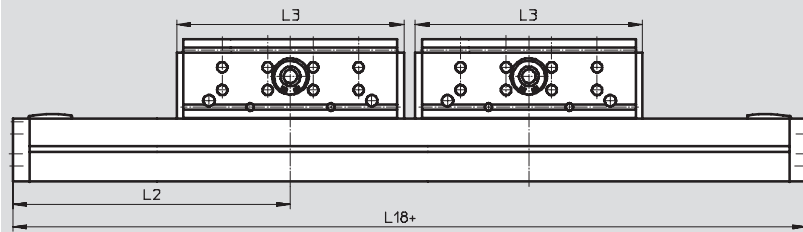

+ = plus stroke length

Profile barrel

Size 18

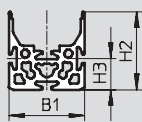

Size 25

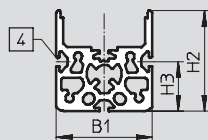

Size 40

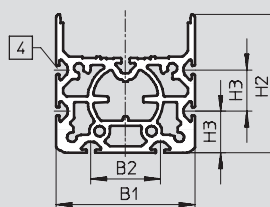

4 Mounting slot for slot nut NST

Size	B1	B2	H2	H3	L2	L3	L18
18	44	-	45	18	210	138	569.5
25	55	-	57.7	28.4	244	202	697.5
40	80	40	85	24	331	256	926

Cantilever axes DGEA, with toothed belt drive

Ordering data – Modules

Order code

Mandatory data/options

WH	Drive shaft, rear
WV	Drive shaft, front
WB	Drive shaft at both ends
ZWK	Second drive head
GVL	Angled gear unit, front left
GVR	Angled gear unit, front right
GHL	Angled gear unit, rear left
GHR	Angled gear unit, rear right

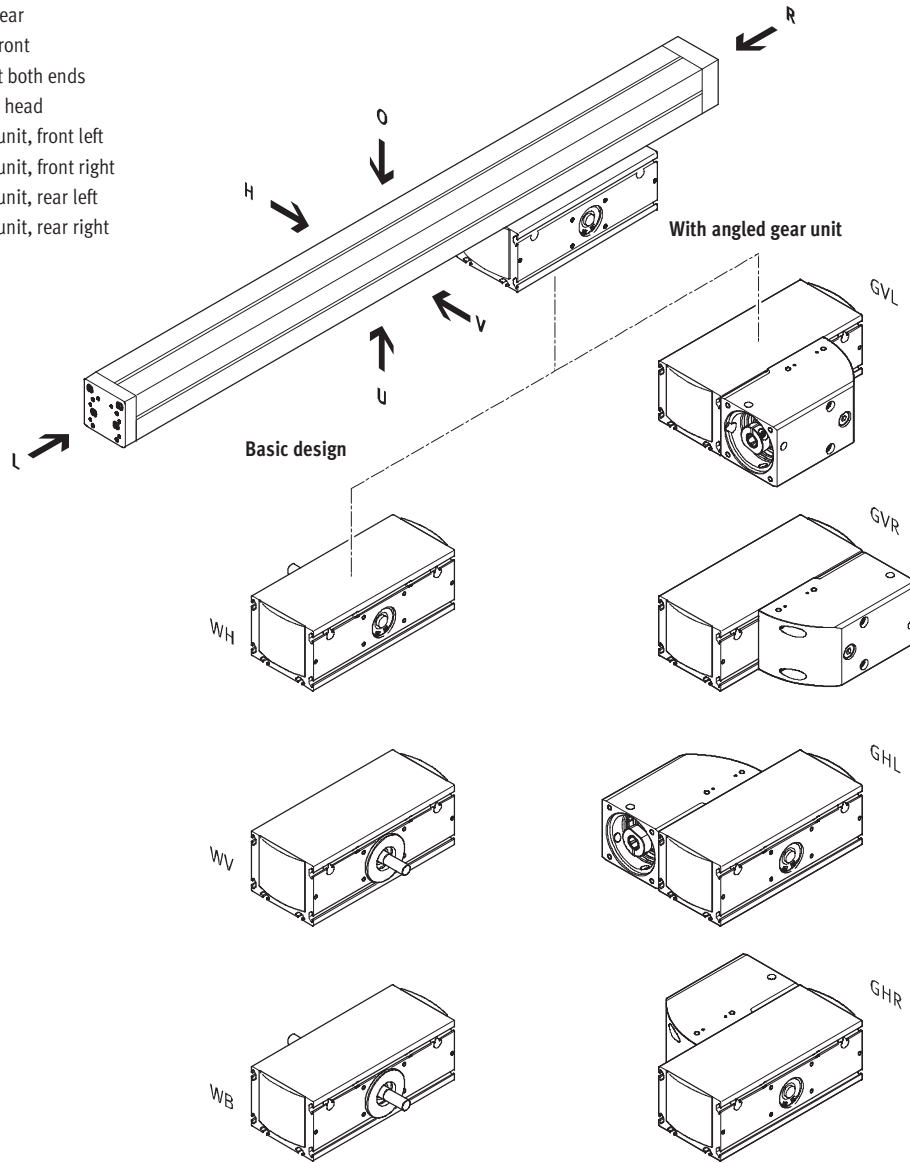

- 1 Drive head
- 2 Optionally:
Additional drive head
(to increase the mechanical
torque resistance)

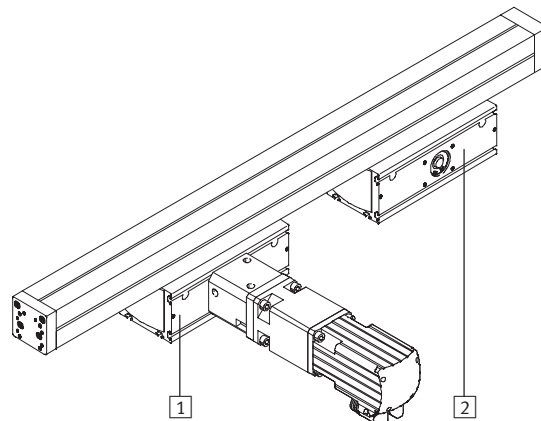

Cantilever axes DGEA, with toothed belt drive

Ordering data – Modules

Order code

Options

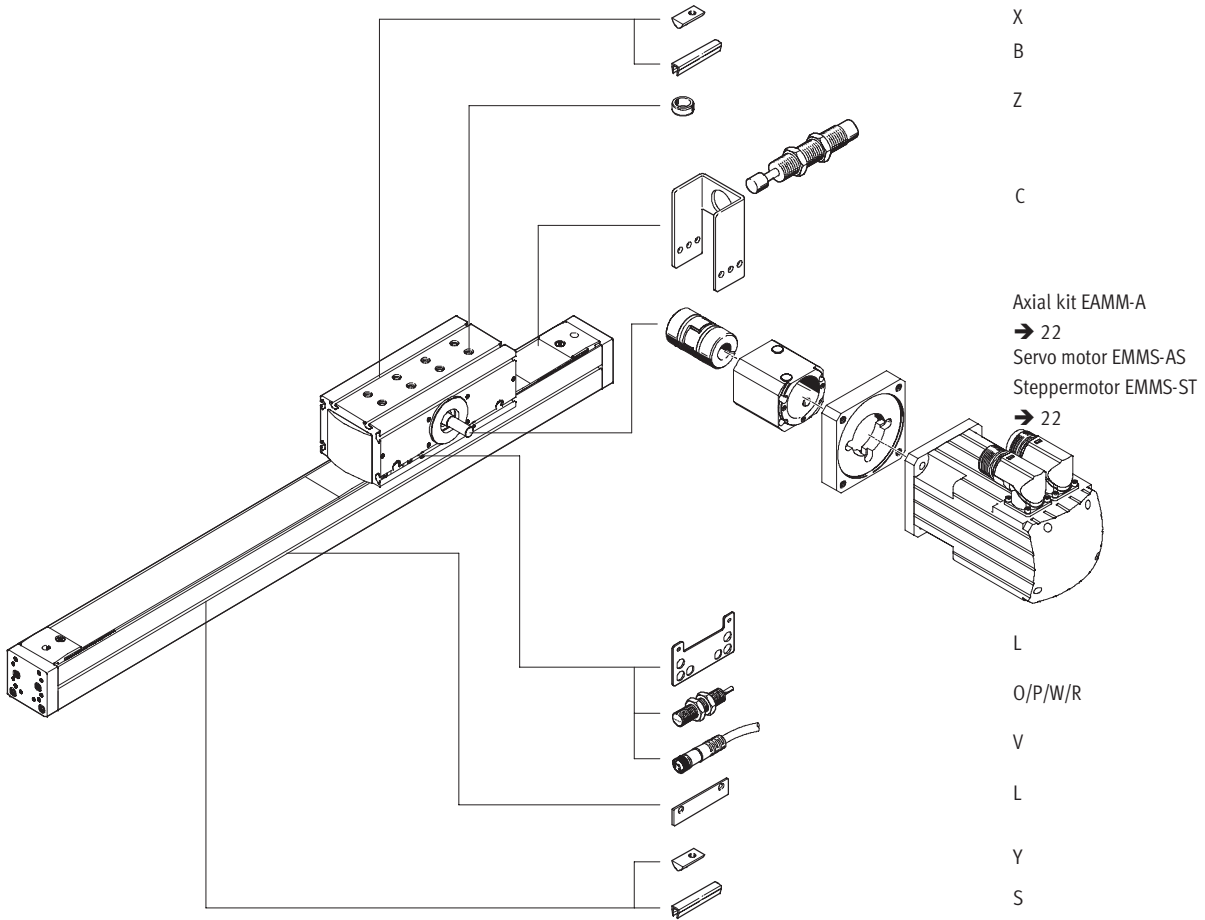

With angled gear unit

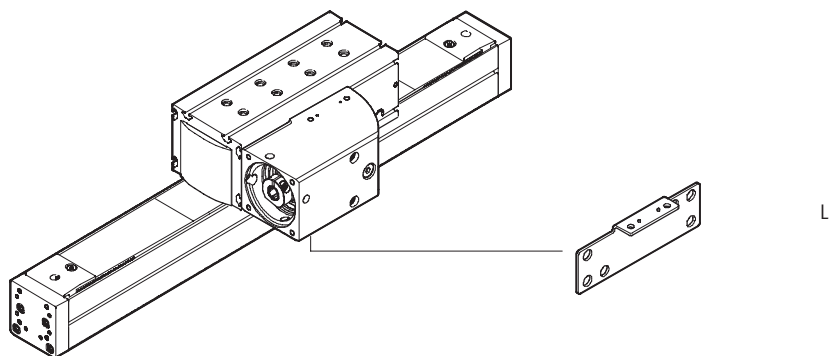

Cantilever axes DGEA, with toothed belt drive

Ordering data – Modules

M Mandatory data						O Options →
Module No.	Construction	Size	Stroke	Drive function	Drive head	Additional drive head
195 611 195 612 195 613	DGEA	18 25 40	1 ... 1000	ZR	WH WV WB GVL GVR GHL GHR	ZWK
Ordering example						
195 612	DGEA	25	850	ZR	WV	

Ordering table						
Size	18	25	40	Condi- tions	Code	Enter code
M Module No.	195 611	195 612	195 613			
Construction	Cantilever axis with toothed belt drive				DGEA	DGEA
Size	18	25	40		-...	
Stroke [mm]	1 ... 800	1 ... 900	1 ... 1000		-...	
Drive function	Electromechanical drive with toothed belt drive				-ZR	-ZR
Drive head	Drive shaft at rear				-WH	
	Drive shaft at front				-WV	
	Drive shaft at both ends				-WB	
	Integrated angled gear unit for arrangement of motor at front left				-GVL	
	Integrated angled gear unit for arrangement of motor at front right				-GVR	
	Integrated angled gear unit for arrangement of motor at rear left				-GHL	
Integrated angled gear unit for arrangement of motor at rear right				-GHR		
Additional drive head	Without drive shaft				-ZWK	

Transfer order code

Cantilever axes DGEA, with toothed belt drive

Ordering data – Modules

Options							
Accessories	Slot cover	Slot nut	Shock absorber with retainer	Centring sleeve	Retaining plate for proximity sensor	Inductive proximity sensor	Cable with socket
ZUB	...S ...B	...Y ...X	...C	...Z	L	...O ...P ...W ...R	...V
ZUB	2B		2C	10Z	L	2P2W	2V

Ordering table							
Size		18	25	40	Condi- tions	Code	Enter code
↓	Accessories	Supplied separately				ZUB-	ZUB-
0	Slot cover	for profile slot	1 ... 10			...S	
		for drive head	1 ... 10			...B	
	Slot nut	for profile slot	1 ... 10			...Y	
		for drive head	1 ... 10			...X	
	Shock absorber with retainer		1 ... 2			...C	
	Centring sleeve		10, 20, 30, 40, 50, 60, 70, 80, 90			...Z	
	Retaining plate for inductive proximity switch, incl. 2 switching lugs		1			L	
	Inductive proximity sensor	NO contact, cable	1 ... 5			...O	
		NC contact, cable	1 ... 5			...P	
		NO contact, plug	1 ... 5			...W	
		NC contact, plug	1 ... 5			...R	
	Cable with socket		1 ... 10			...V	

 - Note

Cantilever axes DGEA offer the same mounting options (on the end cap of the profile and drive head) as the electromechanical axes DGE-...-ZR-KF/-SP-KF



Note however that there is no 1:1 conformity with regard to size. Example: Profile dimension DGEA-18 corresponds to DGE-25.



Transfer order code

ZUB - [] [] [] [] [] [] [] []

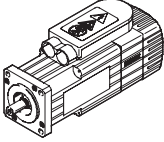
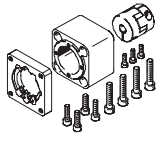
Cantilever axes DGEA, with toothed belt drive

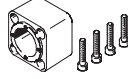
Accessories

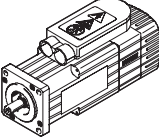
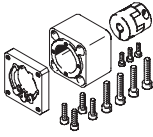
Permissible combinations with axial kit – Basic design without gear unit				
Motor	Axial kit	Axial kit consisting of:		
		Motor flange	Coupling	Coupling housing
				
Type	Part No. Type	Part No. Type	Part No. Type	Part No. Type
DGEA-18				
With stepper motor				
EMMS-ST-57-...	550 956 EAMM-A-F28-57A	530 081 EAMF-A-44A/B-57A	530 088 EAMC-30-35-6.35-8	530 468 EAMK-A-F28-44A
EMMS-ST-87-...	550 958 EAMM-A-F28-87A	530 082 EAMF-A-44A/B-87A	123 042 EAMC-30-35-8-11	530 468 EAMK-A-F28-44A
DGEA-25				
With stepper motor				
EMMS-ST-87-...	550 960 EAMM-A-F32-87A	533 140 EAMF-A-64A/B-87A	530 090 EAMC-40-66-11-11	530 469 EAMK-A-F32-64A

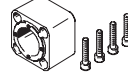
Permissible combinations with axial kit – Basic design with gear unit					
Gear unit	Motor	Axial kit	Axial kit consisting of:		
			Motor flange	Coupling	Coupling housing
					
Type	Type	Part No. Type	Part No. Type	Part No. Type	Part No. Type
DGEA-18					
With servo motor					
EMGA-60-P-G...-SAS-55	EMMS-AS-55-...	550 957 EAMM-A-F28-60G	529 944 EAMF-A-44A/B-60G	123 042 EAMC-30-35-8-11	530 468 EAMK-A-F28-44A
With stepper motor					
EMGA-60-P-G...-SST-57	EMMS-ST-57-...	550 957 EAMM-A-F28-60G	529 944 EAMF-A-44A/B-60G	123 042 EAMC-30-35-8-11	530 468 EAMK-A-F28-44A
DGEA-25					
With servo motor					
EMGA-60-P-G...-SAS-70	EMMS-AS-70-...	550 959 EAMM-A-F32-60G	550 987 EAMF-A-64A/B-60G	530 090 EAMC-40-66-11-11	530 469 EAMK-A-F32-64A
DGEA-40					
With servo motor					
EMGA-80-P-G...-SAS-100	EMMS-AS-100-...	550 935 EAMM-A-F40-80G	533 139 EAMF-A-64A/C-80G	123 845 EAMC-40-66-15-20	124 629 EAMK-A-F40-64A
With stepper motor					
EMGA-80-P-G...-SST-87	EMMS-ST-87-...	550 935 EAMM-A-F40-80G	533 139 EAMF-A-64A/C-80G	123 845 EAMC-40-66-15-20	124 629 EAMK-A-F40-64A

Cantilever axes DGEA, with toothed belt drive

Accessories

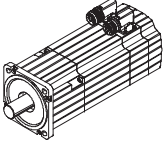
Permissible combinations with angled gear unit	
Motor	
	
Type	
DGEA-18	
With servo motor	
EMMS-AS-55-...	
DGEA-25	
With servo motor	
EMMS-AS-70-...	
DGEA-40	
With servo motor	
EMMS-AS-100-...	

-  - Note

The basic design of the gear units facilitates a reduction of 4 : 1 and that of the angled gear unit a reduction ratio of 3: 1.

Cantilever axes DGEA, with toothed belt drive

Accessories

Axial kit EAMM-A-...

Material:
 Coupling housing, coupling hubs:
 Aluminium
 Clamping component:
 Steel, corrosion resistant
 Motor flange:
 Wrought aluminium alloy
 Screws: Galvanised steel

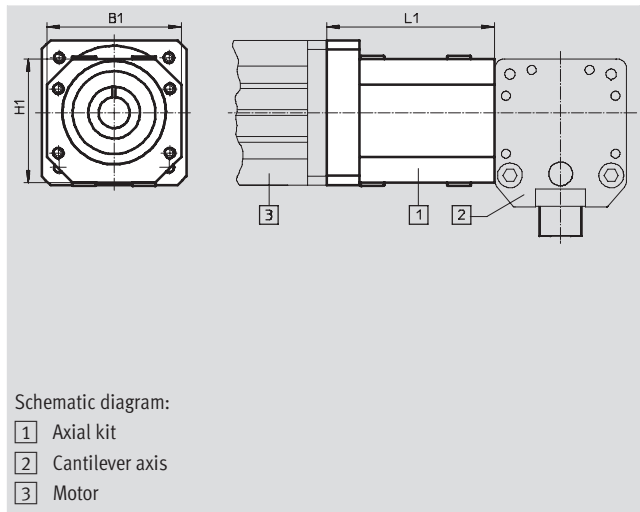

General technical data							
EAMM-A-...		F28-			F32-		F40-
		57A	87A	60G	87A	60G	80G
Transferable torque	[Nm]	7.5	8		17		17
Massenträgheitsmoment	[kgmm ²]	6.1			42.3		42.3
Max. speed	[1/min]	8000			6500		6500
Mounting position		Any					

Operating and environmental conditions		
Ambient temperature	[°C]	0 ... 50
Storage temperature	[°C]	-25 ... +60
Protection class ¹⁾		IP40
Relative air humidity	[%]	0 ... 95

1) Only with combined attachment of motor and axis

Dimensions and ordering data						
Type	B1	H1	L1	Weight [g]	Part No..	Type
EAMM-A-F28-57A	45	45	52.7	282	550 956	EAMM-A-F28-57A
EAMM-A-F28-87A			56.2	454	550 958	EAMM-A-F28-87A
EAMM-A-F28-60G			60.7	345	550 957	EAMM-A-F28-60G
EAMM-A-F32-87A	65	60	82.7	773	550 960	EAMM-A-F32-87A
EAMM-A-F32-60G			89.4	918	550 959	EAMM-A-F32-60G
EAMM-A-F40-80G			89.4	890	550 935	EAMM-A-F40-80G

-  - Note
 Permissible axis/motor combinations
 → 22

Cantilever axes DGEA, with toothed belt drive

Accessories

Mounting kit for proximity sensor
(DGEA in basic design)

DGEA-...-SIE-M8

(Order code: L)

Material:

Galvanised steel

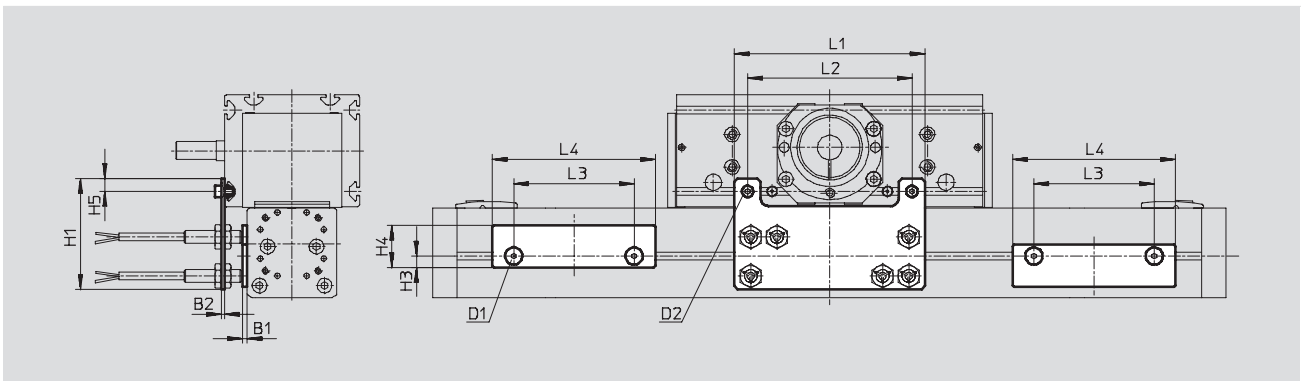

Dimensions and ordering data							
For size	B1	B2	D1	D2	H1	H3	H4
18	3	2	M4	M4	77	5	21
25	3	2	M4	M5	68	7	26
40	3	7	M4	M5	92	7	26

For size	H5	L1	L2	L3	L4	Weights [g]	Part No.	Type
18	7.5	114	90	74	84	200	525 868	DGEA-18-SIE-M8
25	8	117	101	85	100	250	525 869	DGEA-25-SIE-M8
40	10	190	133	124.5	145	600	525 870	DGEA-40-SIE-M8

Cantilever axes DGEA, with toothed belt drive

Accessories



Mounting kit for proximity sensor
(DGEA with angled gear unit)

DGEA-...-G...-SIE-M8

(Order code: L)

Material:

Galvanised steel

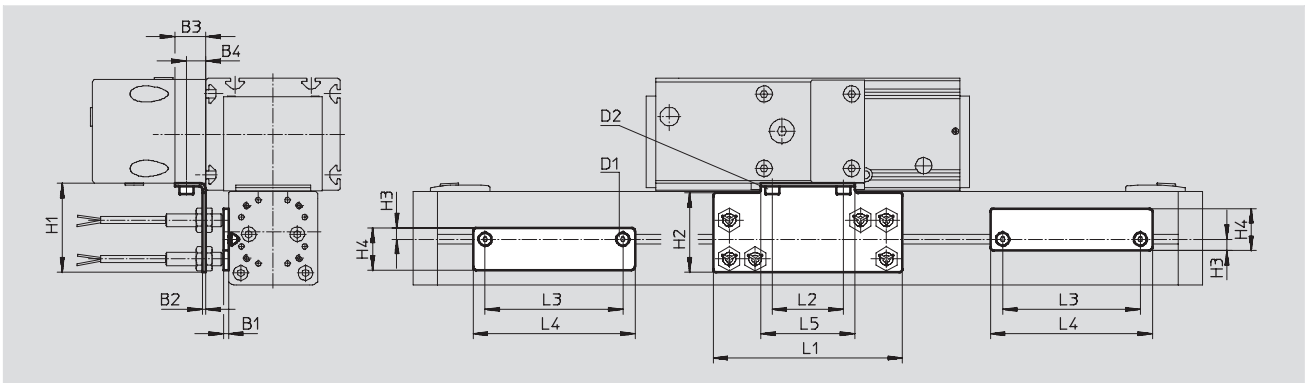
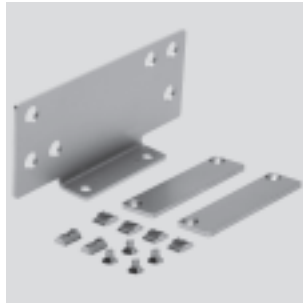

Dimensions and ordering data

For size	B1	B2	B3	B4	D1	D2	H1	H2	H3
18	3	2	17	11	M4	M4	40	34	5
25	3	2	19	12	M4	M5	55	49	7
40	3	4	23	16	M4	M5	64	52	7

For size	H4	L1	L2	L3	L4	L5	Weights [g]	Part No.	Type
18	21	114	34	74	84	46	170	539 935	DGEA-18-G...-SIE-M8
25	26	117	44	85	100	58	250	539 936	DGEA-25-G...-SIE-M8
40	26	153	68	124.5	145	82	520	539 937	DGEA-40-G...-SIE-M8

Cantilever axes DGEA, with toothed belt drive

Accessories

Shock absorber kit

DGEA-...-YSR

(Order code: C)

Material:

Galvanised steel

Copper, PTFE and silicone-free

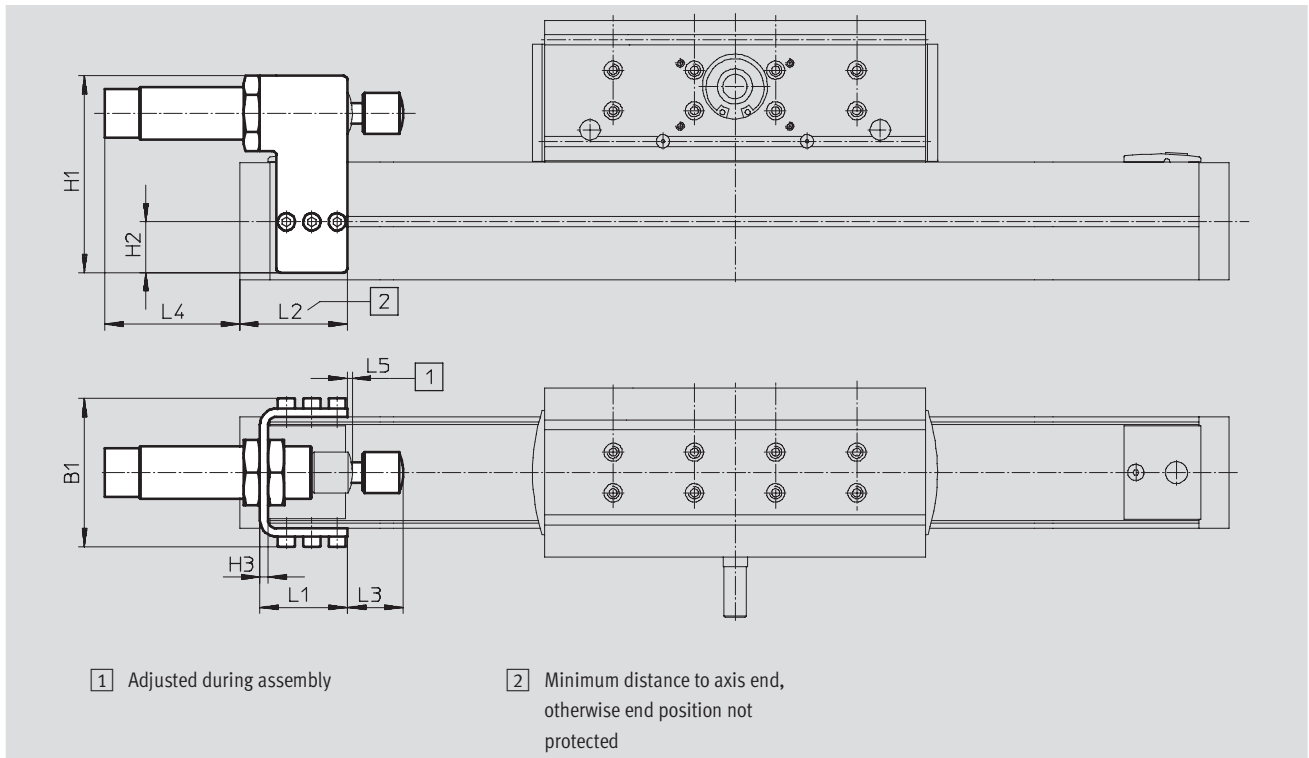



Dimensions and ordering data												
For size	B1	H1	H2	H3	L1	L2 +1	L3	L4	L5 +1	Weights [g]	Part No.	Type
18	59	80	15	3	44	67	1)	1)	2	390	525 865	DGEA-18-YSR
25	73	97	25	4	43	60	1)	1)	2	630	525 866	DGEA-25-YSR
40	98	122	14	4	70.5	81	1)	1)	2	1200	525 867	DGEA-40-YSR

1) Dimension is related to the size of the shock absorber and the mounting position of the shock absorber kit





Cantilever axes DGEA, with toothed belt drive

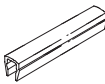

FESTO

Accessories

Ordering data			Technical data → Internet: mounting attachment			
	For size	Remarks	Order code	Part No.	Type	PU ¹⁾
Slot nut NST						
	18	for profile slot	Y	526 091	NST-HMV-M4	1
	25, 40			150 914	NST-5-M5	1
	18, 25, 40	for drive head	X	150 914	NST-5-M5	1
Centring sleeve ZBH						
	18, 25, 40	for drive head	Z	150 927	ZBH-9	10
Slot cover ABP/ABP-S						
	18	for profile slot	S	151 680	ABP-5-S	2
	25, 40	every 0.5 m		151 681	ABP-5	2
	18, 25, 40	for drive head every 0.5 m	B	151 681	ABP-5	2

1) Packaging unit quantity

Ordering data – Inductive proximity sensors M8					Technical data → Internet: sien		
	Electrical connection		Switch output	LED	Cable length [m]	Part No.	Type
	Cables	M8 plug					
NO contact							
	3-core	–	PNP	■	2.5	150 386	SIEN-M8B-PS-K-L
	–	3-pin	PNP	■		150 387	SIEN-M8B-PS-S-L
NC contact							
	3-core	–	PNP	■	2.5	150 390	SIEN-M8B-PO-K-L
	–	3-pin	PNP	■		150 391	SIEN-M8B-PO-S-L

Ordering data – Connecting cables				Technical data → Internet: nebu	
	Electrical connection, left	Electrical connection, right	Cable length [m]	Part No.	Type
	Straight socket, M8x1, 3-pin	Cable, open end, 3-wire	2.5	541 333	NEBU-M8G3-K-2.5-LE3
			5	541 334	NEBU-M8G3-K-5-LE3
	Angled socket, M8x1, 3-pin	Cable, open end, 3-wire	2.5	541 338	NEBU-M8W3-K-2.5-LE3
			5	541 341	NEBU-M8W3-K-5-LE3