

Toothed belt axes DGE

FESTO

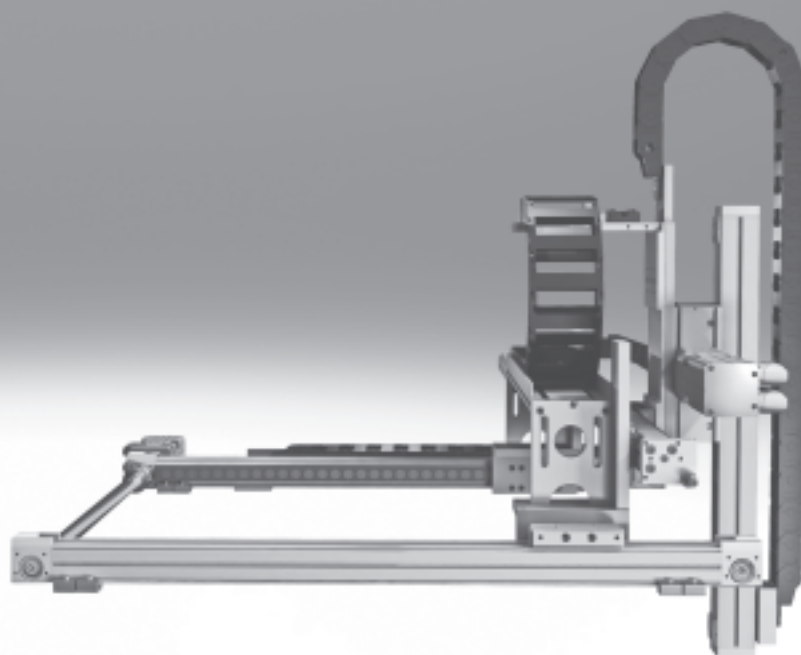

Toothed belt axes DGE

Key features

FESTO

At a glance

- Precision, rigid guide
- Highly adaptable, thanks to wide choice of mounting and attachment options
- Wide range of options for attaching drive units
- Comprehensive range of mounting accessories for multi-axis combinations
- Optimally adapted motor controller combinations

Basic version DGE-ZR

- Stroke lengths from 1 ... 4500 mm
- Without guide
- Low characteristic load values



With recirculating ball bearing guide DGE-ZR-KF

- Stroke lengths from 1 ... 4500 mm
- Standard slide or extended slide
- Medium to high characteristic load values



With protected version DGE-ZR-KF-GA

- Stroke lengths from 1 ... 1800 mm
- Standard slide
- Guide and slide are fitted with a cover to protect against the ingress of particles from above and the side



With roller guide DGE-ZR-RF

- Stroke lengths from 1 ... 5000 mm
- Standard slide or extended slide
- Internal, protected roller guide
- Medium characteristic load values
- High speeds possible



With heavy-duty guide DGE-ZR-HD

- Stroke lengths from 1 ... 2000 mm
- High guide precision
- Sturdy construction
- High characteristic load values



Toothed belt axes DGE

Key features

System selection for electromechanical drives

Toothed belt axis



Note

For the toothed-belt axes and the motors there are matching complete solutions.

Motor kit

Axial kit

→72



Axial kit consisting of:

- Motor flange
- Coupling housing
- Coupling
- Screws

Motor

→72



- 1 Servo motor EMMS-AS
- 2 Stepper motor EMMS-ST

Motor controller

Technical data → Internet: motor controller



- 1 Servo motor ontroller CMMP-AS, CMMS-AS
- 2 Stepper motor controller CMMS-ST

Toothed belt axes DGE

System example

FESTO

System product for handling and assembly technology

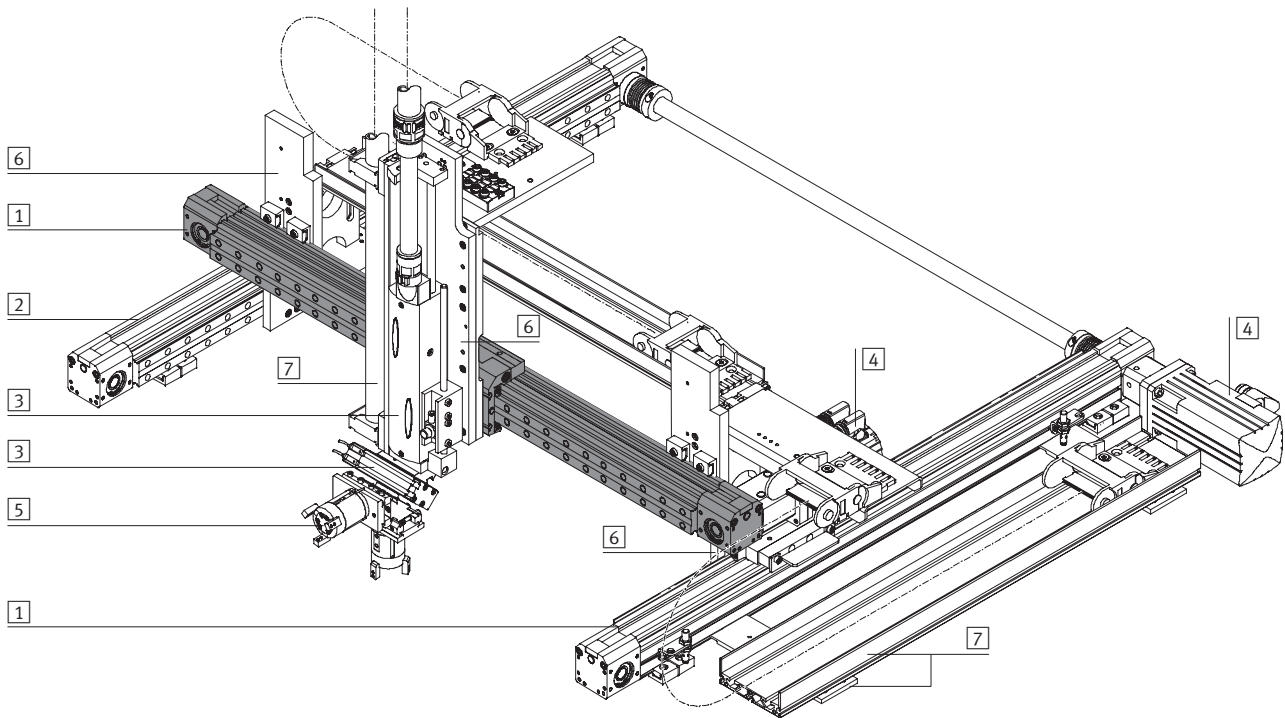

System components and accessories		
Type	Brief description	→ Page/Internet
1	Axes	Wide range of combination options within handling and assembly technology axes
2	Passive guide axes	Diverse possible combinations in handling and assembly technology guide axes
3	Drives	Wide range of combination options within handling and assembly technology drive
4	Motors	Servo and stepper motors, with or without gearing motor
5	Grippers	Wide range of combination options within handling and assembly technology gripper
6	Adapters	For combining drives with drives and drives with grippers adapter kit
7	Installation components	For achieving a clear-cut, safe layout for electrical cables and tubing installation component

Toothed belt axes DGE

Selection aid

Guide characteristics

The data in the table are maximum values. The precise values for each variant can be found in the corresponding data sheet included in the catalogue.

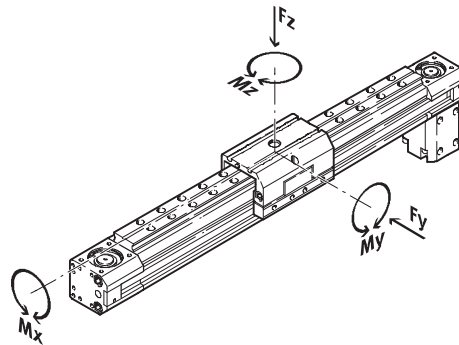

Version	Size	Working stroke ¹⁾ [mm]	Speed [m/s]	Repetition accuracy [mm]	Feed force [N]	Forces and torques					→ Page/Internet
						Fy [N]	Fz [N]	Mx [Nm]	My [Nm]	Mz [Nm]	
Basic version without guide ZR											
	8	1 ... 650	1	±0.08	15	–	38	0.15	2	0.3	6
	12	1 ... 1000	1.5	±0.08	30	–	59	0.3	4	0.5	
	18	1 ... 1000	2	±0.08	60	–	120	0.5	11	1	
	25	1 ... 3000	5	±0.1	260	–	330	1	20	3	
	40	1 ... 4000	5	±0.1	610	–	800	4	60	8	
	63	1 ... 4500	5	±0.1	1500	–	1600	8	120	24	
With recirculating ball bearing guide ZR-KF											
	8	1 ... 650	1	±0.08	15	255	255	1	3.5	3.5	22
	12	1 ... 1000	1.5	±0.08	30	565	565	3	9	9	
	18	1 ... 1000	2	±0.08	60	930	930	7	45	45	
	25	1 ... 3000	3	±0.1	260	3080	3080	45	170	170	
	40	1 ... 4000	3	±0.1	610	7300	7300	170	660	660	
	63	1 ... 4500	3	±0.1	1500	14050	14050	580	1820	1820	
With roller guide ZR-RF											
	25	1 ... 5000	10	±0.1	260	260	150	7	30	30	44
	40	1 ... 5000	10	±0.1	610	610	300	18	120	180	
	63	1 ... 5000	10	±0.1	1500	1500	600	65	340	600	
With heavy-duty guide ZR-HD											
	18	1 ... 1000	3	±0.08	60	1820	1820	70	115	112	58
	25	1 ... 1000	3	±0.1	260	5400	5600	260	415	400	
	40	1 ... 1000	3	±0.1	610	5400	5600	375	560	540	

1) Special lengths on request

- - Note
 Sizing software
 PositioningDrives
 → www.festo.com

Toothed belt axes DGE-ZR

Peripherals overview

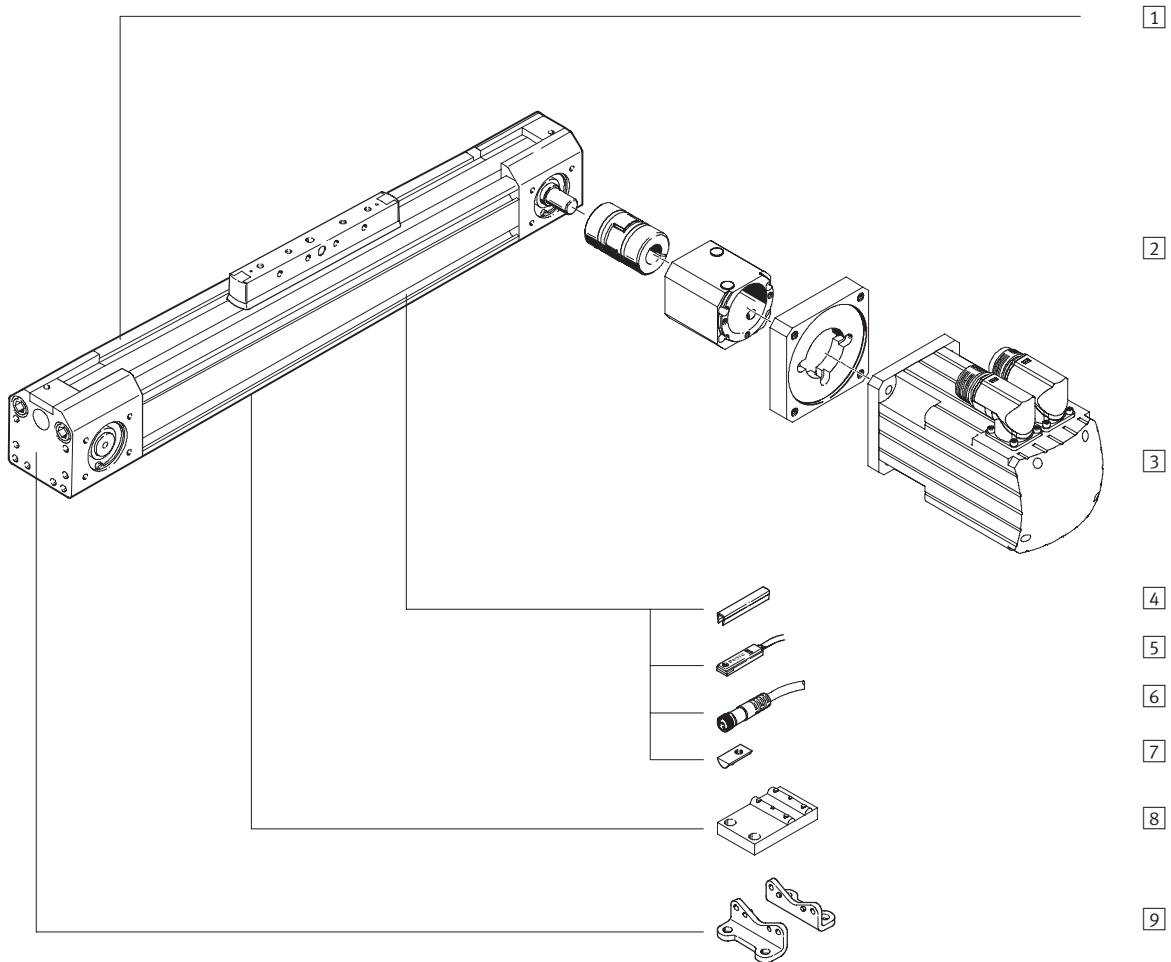

Toothed belt axes DGE-ZR

Peripherals overview

Variants and accessories		
Type	Brief description	→ Page/Internet
1 Toothed belt axis DGE-ZR	Electromechanical axis without guide	8
2 Axial kit EAMM-A	For axial motor attachment (consisting of: coupling housing, clamping component, motor flange)	72
3 Motor EMMS	Motors specially matched to the axis, with or without gearing, with or without brake	72
4 Slot cover B/S	For protecting against the ingress of dirt	86
5 Proximity sensor G/H/I/J/N	For use as a proximity signal and safety monitoring	87
6 Cable with socket V	For proximity sensors	87
7 Slot nut for mounting slot Y	For mounting attachments	86
8 Central support M	For mounting the axis	79
9 Foot mounting F	For mounting the axis	78

Toothed belt axes DGE-ZR

Type code

	DGE	-	25	-	500	-	ZR	-	LK	-	RV
Type											
DGE	Toothed belt drive										
Size											
Stroke [mm]											
Drive function											
ZR	Toothed belt										
Drive shaft on left											
LK	No drive shaft on left										
LV	Drive shaft on left, front										
LH	Drive shaft on left, rear										
LB	Drive shaft on left, front and rear										
Drive shaft on right											
RK	No drive shaft on right										
RV	Drive shaft on right, front										
RH	Drive shaft on right, rear										
RB	Drive shaft on right, front and rear										

Toothed belt axes DGE-ZR

Type code

→		+ ZUB	-				F	2G	
Accessories									
ZUB	Accessories supplied loose								
Slot cover									
...S	Sensor slot								
...B	Mounting slot								
Slot nut									
...Y	For mounting slot								
Central support									
...M	Central support								
Foot mounting									
...F	Foot mounting								
Proximity sensor									
...G	With cable, 2.5 m								
...H	With plug								
...I	Contactless, with cable, 2.5 m								
...J	Contactless, plug								
...N	NC contact with cable, 2.5 m								
Cable with socket									
...V	2.5 m								

Toothed belt axes DGE-ZR

Technical data

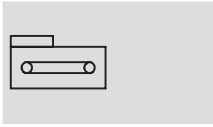

FESTO

Function

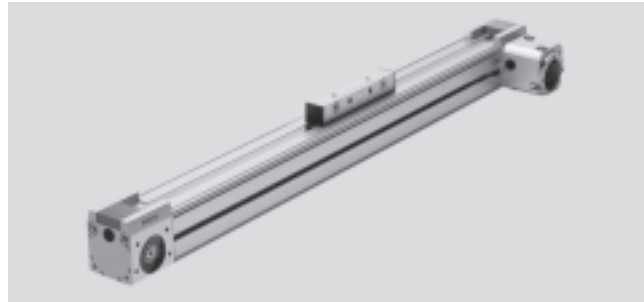

 www.festo.com



-  Size
8 ... 63
-  Stroke length
1 ... 4500 mm

General technical data							
Size		8	12	18	25	40	63
Constructional design		Electromechanical axis with toothed belt					
Guide		-					
Mounting position		Any					
Max. working stroke ¹⁾	[mm]	1 ... 650	1 ... 1000	1 ... 1000	1 ... 3000 ²⁾	1 ... 4000 ²⁾	1 ... 4500 ²⁾
Max. feed force F_x	[N]	15	30	60	260	610	1500
Max. radial force ³⁾	[N]	103	77	290	307	984	2600
Radial force ⁴⁾	[N]	56	96	117	235	370	840
Radial force ⁵⁾	[N]	40	70	80	140	170	400
Max. driving torque	[Nm]	0.08	0.18	0.5	2.6	9.7	42
Max. no-load driving torque ⁶⁾	[Nm]	0.05	0.08	0.2	0.5	1.0	4.5
Max. speed	[m/s]	1	1.5	2	5	5	5
Max. acceleration	[m/s ²]	15	20	20	50	50	50
Repetition accuracy	[mm]	±0.08			±0.1		

- 1) Total stroke = working stroke + 2x stroke reserve
- 2) Special lengths on request
- 3) On the drive shaft
- 4) On the drive shaft, with a service life of 5,000 km
- 5) On the drive shaft, with a service life of 10,000 km
- 6) Measured at a speed of 0.2m/s

Operating and environmental conditions							
Size		8	12	18	25	40	63
Ambient temperature	[°C]	-10 ... +40					
Protection class		IP40					

Weights [kg]							
Size		8	12	18	25	40	63
Basic weight with 0 mm stroke ¹⁾		0.237	0.31	0.862	1.89	6.05	23.2
Additional weight per 100 mm stroke		0.05	0.08	0.16	0.32	0.51	1.8
Moving load		0,012	0,02	0,055	0,28	0,60	1,80

- 1) Including coupling housing

Mass moment of inertia							
Size		8	12	18	25	40	63
J_0	[kg cm ²]	0.006	0.015	0.064	0.38	2.34	25.6
J_H per metre stroke	[kg cm ² /m]	0.003	0.009	0.021	0.078	0.45	3.6
J_L per kg working load	[kg cm ² /kg]	0.259	0.365	0.685	1	2.53	7.85

The mass moment of inertia J_A of the entire axis is calculated as follows:

$$J_A = J_0 + J_H \times \text{working stroke [m]} + J_L \times m_{\text{working load [kg]}}$$

Toothed belt axes DGE-ZR

Technical data

FESTO

Toothed belt							
Size		8	12	18	25	40	63
Tensile stress ¹⁾	[%]	0.04	0.1	0.2	0.11	0.1	0.15
Pitch	[mm]	2	2	2	3	5	8
Effective diameter	[mm]	10.18	12.09	16.55	20.05	31.83	56.02
Feed constant	[mm/rev.]	32	38	52	63	100	176

1) At max. feed force

Materials

Sectional view

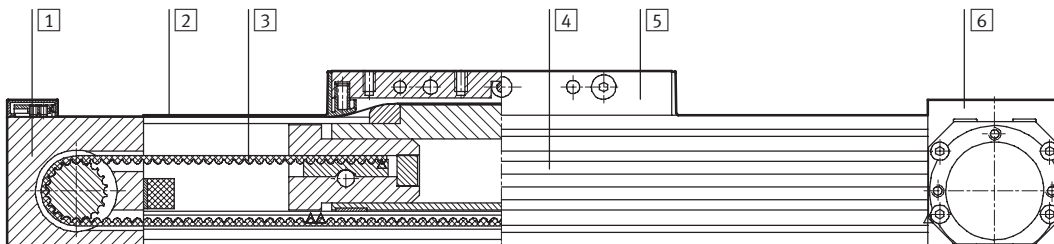

Axis

1	Return pulley housing	Anodised aluminium
2	Cover strip	Corrosion resistant steel
3	Toothed belt	Polychloroprene with Glascord and nylon coating
4	Profile	Anodised aluminium
5	Slide	Anodised aluminium
6	Drive housing	Anodised aluminium

Stroke reserve

L1+ Overall length of axis
L11 Internal mechanical stop

1 The working stroke is the effective usable work range. Please quote this in your order.

L12 Stroke reserve:
Safety distance to mechanical stop, present at both ends of the axis in addition to the stroke

Example:
Type DGE-25-500-ZR
Working stroke = 500 mm
Stroke reserve = (2x 63 mm)
= 126 mm
Total stroke:
626 mm = 500 mm + 126 mm

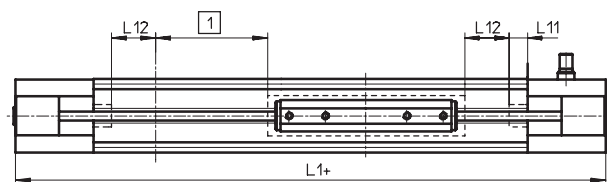

Size		8	12	18	25	40	63
L12 per end position	[mm]	27.5	36.5	46.5	63	100	172

Toothed belt axes DGE-ZR

Technical data

Characteristic load values

The indicated forces and torques refer to the centre line of the internal diameter of the profile.

They must not be exceeded in the dynamic range. Special attention must be paid to the cushioning phase.

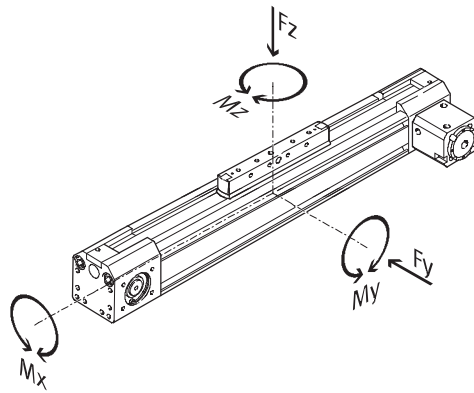

If the drive is subjected to more than two of the indicated forces and torques simultaneously, the following equations must be satisfied in addition to the indicated maximum loads.

$$0.4 \times \frac{F_z}{F_{z_{max}}} + \frac{M_x}{M_{x_{max}}} + \frac{M_y}{M_{y_{max}}} + 0.2 \times \frac{M_z}{M_{z_{max}}} \leq 1$$

$$\frac{F_z}{F_{z_{max}}} \leq 1 \quad \frac{M_z}{M_{z_{max}}} \leq 1$$

Permissible forces and torques							
Size		8	12	18	25	40	63
F _y _{max.}	[N]	–	–	–	–	–	–
F _z _{max.}	[N]	38	59	120	330	800	1600
M _x _{max.}	[Nm]	0.15	0.3	0.5	1	4	8
M _y _{max.}	[Nm]	2	4	11	20	60	120
M _z _{max.}	[Nm]	0.3	0.5	1	3	8	24

2nd moment of area

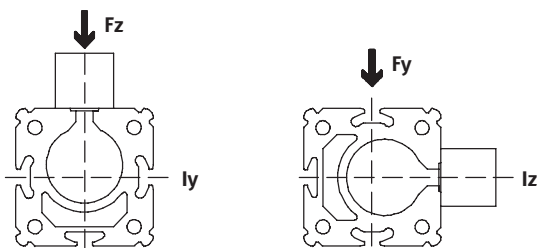

Size		8	12	18	25	40	63
I _y	[mm ⁴]	6.6x10 ³	19.7x10 ³	69.8x10 ³	224x10 ³	673x10 ³	5688x10 ³
I _z	[mm ⁴]	6.7x10 ³	19.1x10 ³	72.3x10 ³	240x10 ³	748x10 ³	6031x10 ³

-  - Note

Sizing software
PositioningDrives
→ www.festo.com

Toothed belt axes DGE-ZR

Technical data

Maximum permissible support span l as a function of the force F

The drive may need to be supported with central supports MUP in order to restrict deflection with long stroke

lengths. The following diagrams serve to determine the maximum permissible support span l as a

function of the force acting upon the drive F .

1 Force on the surface of the slide

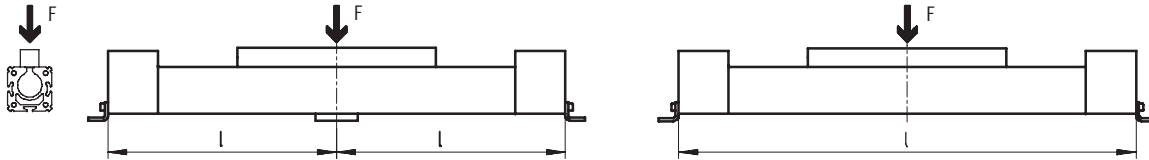

2 Force on the front of the slide

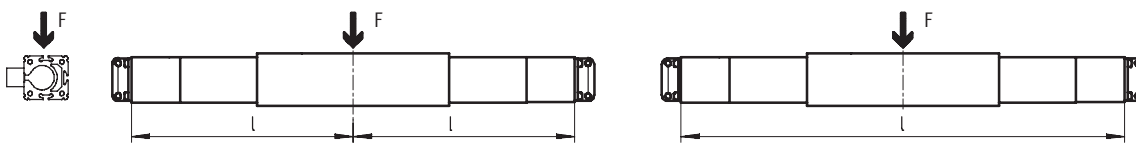

Maximum permissible support span l (without central support) as a function of the force F

DGE-8

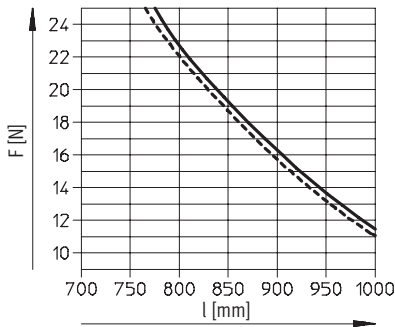

DGE-12

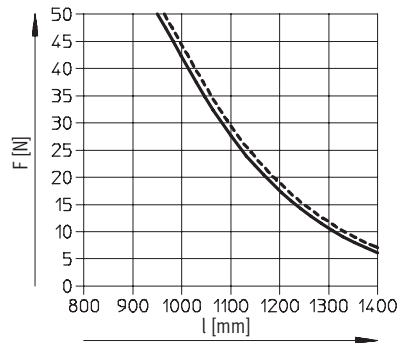

DGE-18

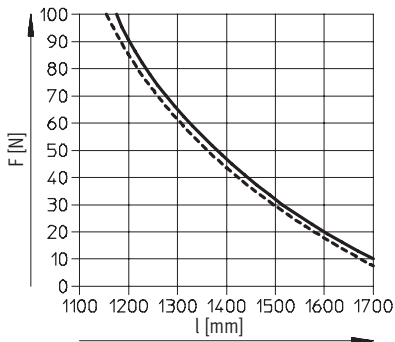

DGE-25

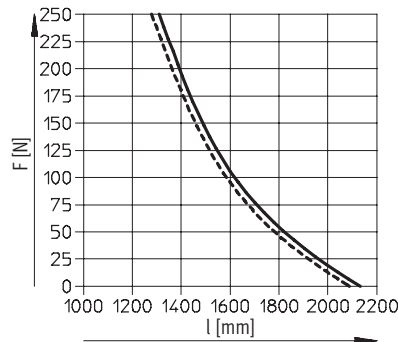

DGE-40

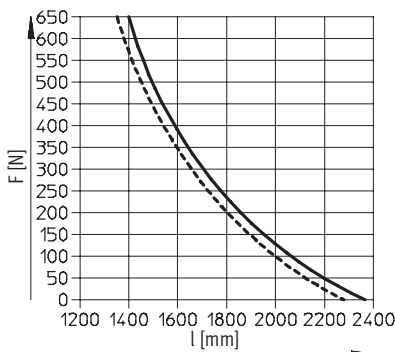

DGE-63

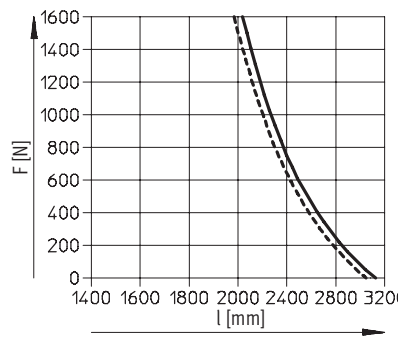

— 1
- - - 2

Toothed belt axes DGE-ZR

Technical data

FESTO

Dimensions

Download CAD data → www.festo.com

Size 8 ... 18

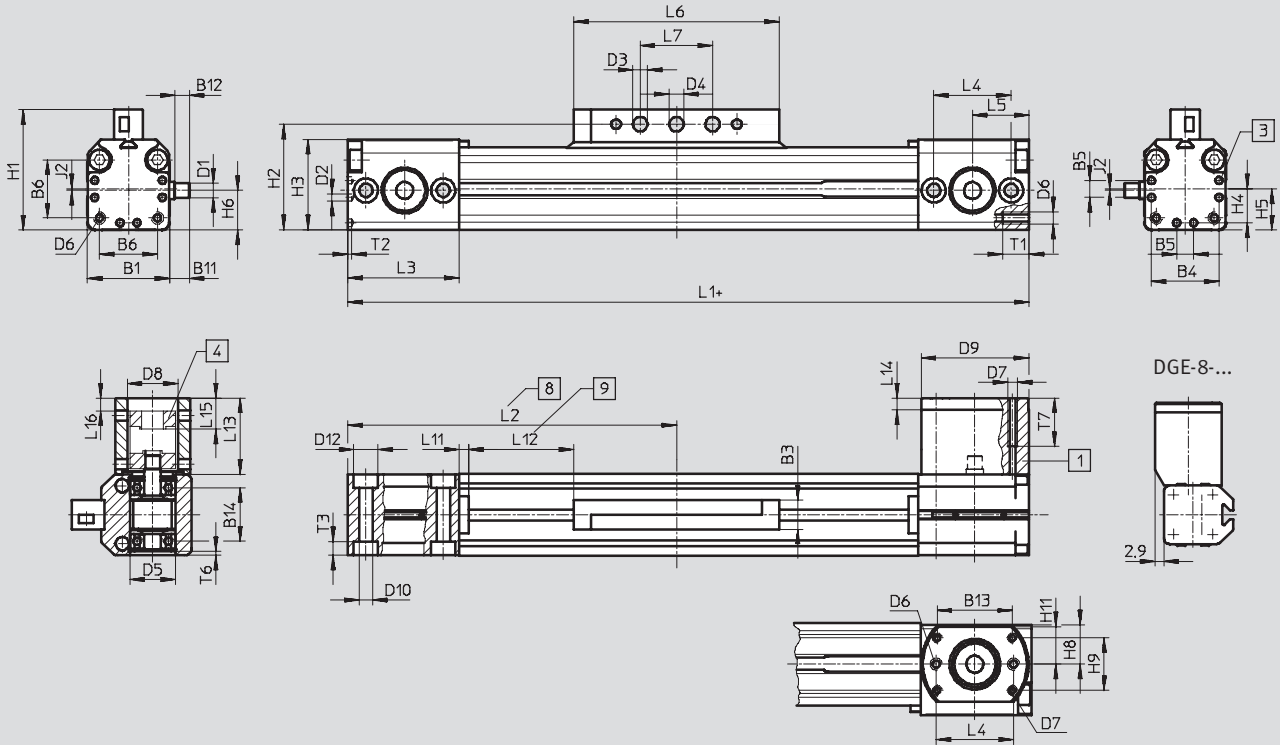

- 1 Coupling housing
- 2 Centring hole for foot mounting
- 3 Coupling
- 4 Driver in end position of working stroke (stroke reserve up to mechanical stop still present)
- 5 Stroke reserve → 11
- 6 + = plus stroke length

Profile

Size 8

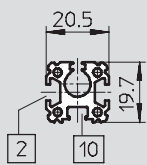

Size 12

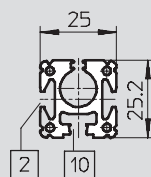

Size 18

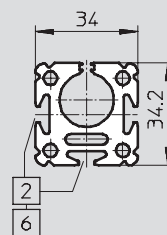

- 2 Sensor slot for proximity sensor
- 6 Mounting slot for slot nut NST
- 10 Not suitable for proximity sensor

Toothed belt axes DGE-ZR

Technical data

Size	B1 +0.2	B3 ±0.1	B4	B5	B6	B11	B12	B13	B14	D1 ∅ g6	D2 ∅	D3 ∅ H11	D4 ∅ H7	D5 ∅	D6	D7
8	20.5	8	16	4	13	7.3	5	-	12	4	2	3.4	4	12	M3	M3
12	25	8	21	6	18.6	8.7	6.5	22.7	16.2	4	2	3.4	4	16	M3	M3
18	34	12	28	7	24	7.7	5.5	31.1	22	6	3	5.4	6	19	M5	M4

Size	D8 ∅	D9 ∅ g7	D10	D12	H1	H2	H3	H4	H5	H6	H8	H9	H11	J2	L1	L2
8	16	28.7	3.4	M4	30	26.5	23.1	8	9.8	8.1	11	0	11	1.7	180	90
12	16	30	3.4	M4	35.5	32	28.6	10.5	12.5	11.8	11	13.1	11	0.7	216	108
18	21	44	5.5	M5	49.8	43.8	37.6	14	17	16.4	15.5	21.8	15.5	0.6	282	141

Size	L3	L4 ±0.1	L5	L6 +4	L7 ±0.1	L11 ±0.1	L12	L13	L14	L15	L16	T1	T2	T3	T6	T7
8	30	21	15.5	52	15	4	27.5	27.5	5	9.7	3.2	7	1.1	3.4	0.7	18.8
12	33	24	17	64	15	4	36.5	29	5	11.3	4.8	7	1.1	3.4	0.8	29
18	46	32	23.5	85	30	4	46.5	31.5	5	12.8	5.3	11	1.6	5.7	1.5	19

Toothed belt axes DGE-ZR

Technical data

FESTO

Dimensions

Download CAD data → www.festo.com

Size 25 ... 63

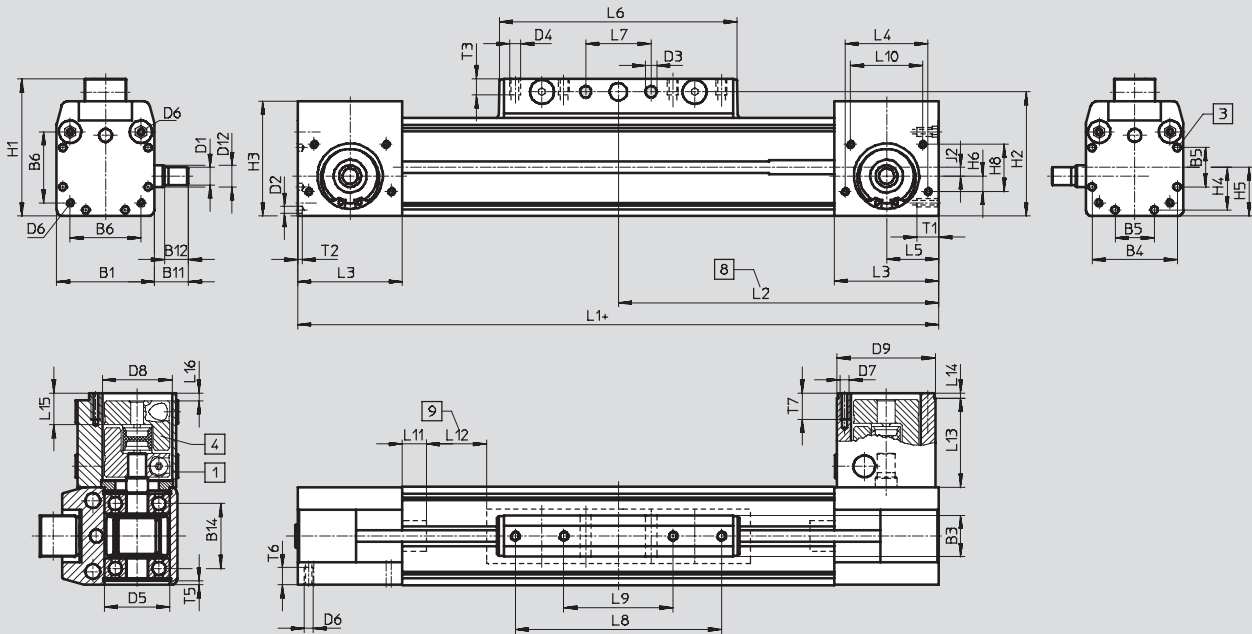

Size 63

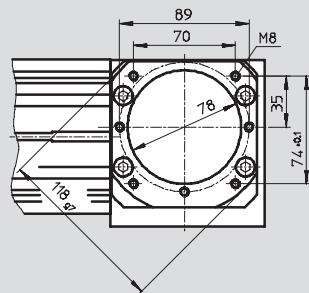

Size 25/40

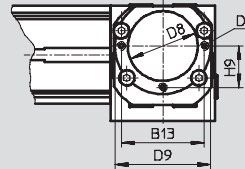

- 1 Coupling housing
- 3 Centring hole for foot mounting HP
- 4 Coupling

- 8 Driver in end position of working stroke (stroke reserve up to mechanical stop still present)

- 9 Stroke reserve → 11
- + = plus stroke length

Profile

Size 25

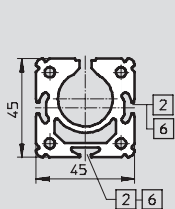

Size 40

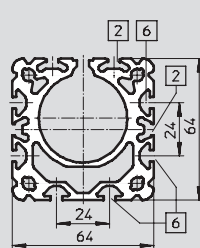

Size 63

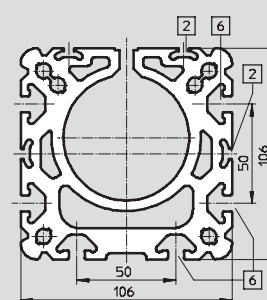

- 2 Sensor slot for proximity sensor
- 6 Mounting slot for slot nut NST

Toothed belt axes DGE-ZR

Technical data

Size	B1	B3 +0.2	B4	B5	B6	B11	B12	B13	B14	D1 ∅ h6	D2 ∅	D3 ∅ +0.2	D4
25	45	19	39.1	18	32.5	15.5	11	38	29.8	8	3.3	5.2	M5
40	64	21	53	28	49	30	24.5	56	43.5	15	4.3	6.5	M6
63	106	24	89	44	83	41	35	-	77.7	25	6.3	8.5	M8

Size	D5 ∅ H7	D6	D7	D8 ∅	D9 ∅ g7	D12 ∅	H1	H2	H3	H4	H5	H6	H8
25	30	M4	M4	32	44	10	63	57	52.8	19.6	22.5	7	21.6
40	40	M5	M6	48	64	17	86	78	71.8	26.5	32	11.5	31
63	62	M8	M8	78	-	31	131	122	115	44.5	53	21.5	49

Size	H9 ±0.1	J2	L1	L2	L3	L4	L5	L6	L7 ±0.1	L8 ±0.1	L9 ±0.1	L10
25	19	4.1	372	186	48	38	24	109	30	-	50	33
40	28	5	569	284.5	67	54	34	171	70	130	40	54
63	35	6.5	882	441	106	84	55	234	110	190	70	84

Size	L11	L12	L13	L14	L15	L16 ¹⁾	T1	T2	T3	T5	T6	T7
25	11	63	40	3.2	14.6	3.6	10	2	7.5	1.4	8	10
40	15	100	65	4	22.8	-2.2	12	3	10.5	1.9	10	13
63	15	172	91	5	35	0	21	4	12.5	4.5	15	16

1) Negative dimension: Protrudes above coupling housing

Toothed belt axes DGE-ZR

Ordering data – Modular products

Order code

Mandatory data

- LK No drive shaft on left
- LV Drive shaft on left, front
- LH Drive shaft on left, rear
- LB Drive shaft on left, front and rear
- RK No drive shaft on right
- RV Drive shaft on right, front
- RH Drive shaft on right, rear
- RB Drive shaft on right, front and rear

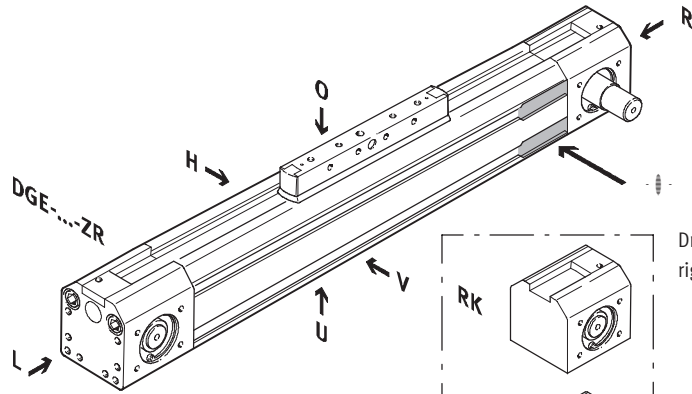

Drive shaft left

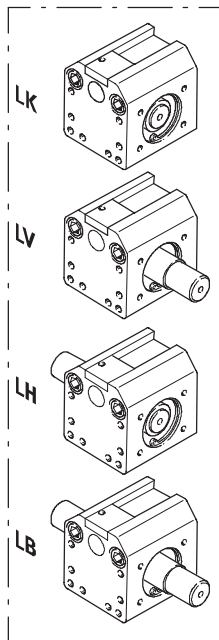

Drive shaft right

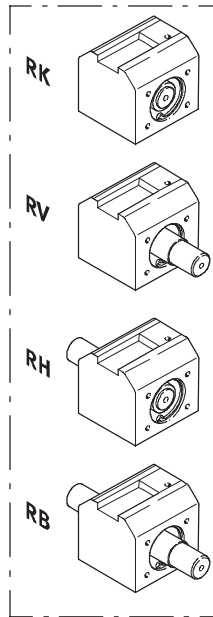

-  - Note

The insertion point for the proximity sensor is located on the right side of the toothed belt axis DGE-ZR

- O top
- U underneath
- R right
- L left
- V front
- H rear

Toothed belt axes DGE-ZR

Ordering data – Modular products

Order code

Options

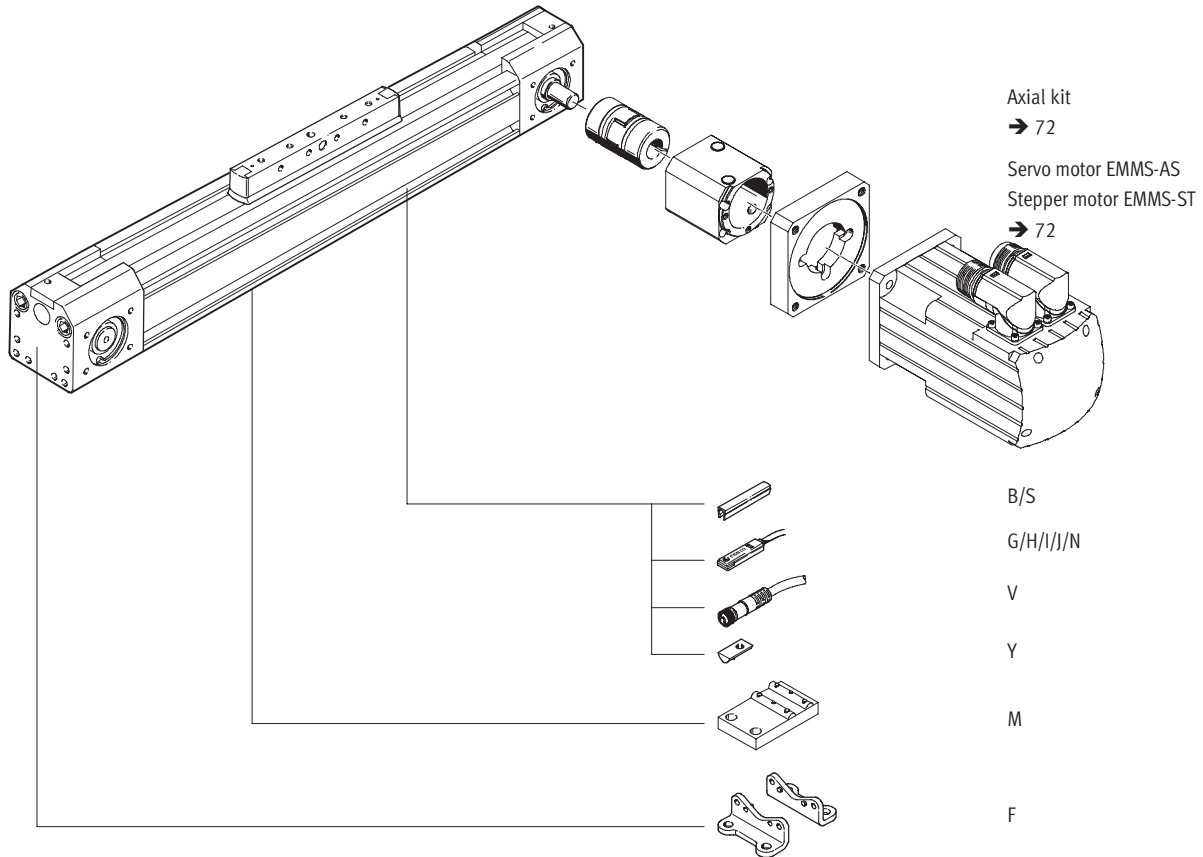

Toothed belt axes DGE-ZR

Ordering data – Modular products

M Mandatory data →

Module No.	Design	Size	Stroke	Drive function	Drive shaft on left	Drive shaft on right
193 739	DGE	8	1 ... 4 500	ZR	LK	RK
193 740		12			LV	RV
193 741		18			LH	RH
193 742		25			LB	RB
193 743		40				
193 744		63				
Ordering example						
193 742	DGE	25	500	ZR	LK	RV

Ordering table										
Size	8	12	18	25	40	63	Condi- tions	Code	Enter code	
M Module No.	193 739	193 740	193 741	193 742	193 743	193 744				
Design	Electromechanical linear axis							DGE	DGE	
Size	8	12	18	25	40	63	-...			
Stroke [mm]	1 ... 650	1 ... 1000		1 ... 3000	1 ... 4000	1 ... 4500	[1]	-...		
Drive function	Electromechanical drive with toothed belt							-ZR	-ZR	
Drive shaft on left	No drive shaft on left							[2]	-LK	
	Drive shaft on left, front								-LV	
	Drive shaft on left, rear								-LH	
	Drive shaft on left, front and rear								-LB	
Drive shaft on right	No drive shaft on right							[3]	-RK	
	Drive shaft on right, front								-RV	
	Drive shaft on right, rear								-RH	
	Drive shaft on right, front and rear								-RB	

[1] **Stroke** Special stroke lengths:
 Module No. 8: 1000 mm
 Module No. 12: 1400 mm
 Module No. 18: 1700 mm
 Module No. 25: 5100 mm
 Module No. 40: 4900 mm
 Module No. 63: 4700 mm

[2] **LK** Not with drive shaft on right RK.
 [3] **RK** Not with drive shaft on left LK.

Transfer order code

Toothed belt axes DGE-ZR

Ordering data – Modular products



Options						
Accessories	Slot cover	Slot nut	Central support	Foot mounting	Proximity sensor	Plug socket
ZUB	...S ...B	...Y	...M	...F	...G ...H ...I ...J ...N	...V
ZUB	- 2S	10Y		F	2G	2V

Ordering table											
Size		8	12	18	25	40	63	Condi- tions	Code	Enter code	
↓	Accessories	Supplied separately							ZUB-		ZUB-
0	Slot cover	Sensor slot	1 ... 10					...S			
		Mounting slot	-	-	-	-	1 ... 10	...B			
	Slot nut	for mounting slot	-	-	1 ... 10			...Y			
	Central support	1 ... 10					...M				
	Foot mounting (kit)	1 ... 10					...F				
	Proximity sensor	with cable 2.5 m	1 ... 10					...G			
		with plug	1 ... 10					...H			
		contactless with cable 2.5 m	1 ... 10					...I			
		contactless, plug	1 ... 10					...J			
		NC contact with cable 2.5 m	1 ... 10					...N			
	Cable with socket, 2.5 m	1 ... 10					...V				

Transfer order code

ZUB	-						
-----	---	--	--	--	--	--	--

Toothed belt axes DGE-ZR-KF, with recirculating ball bearing guide

Peripherals overview

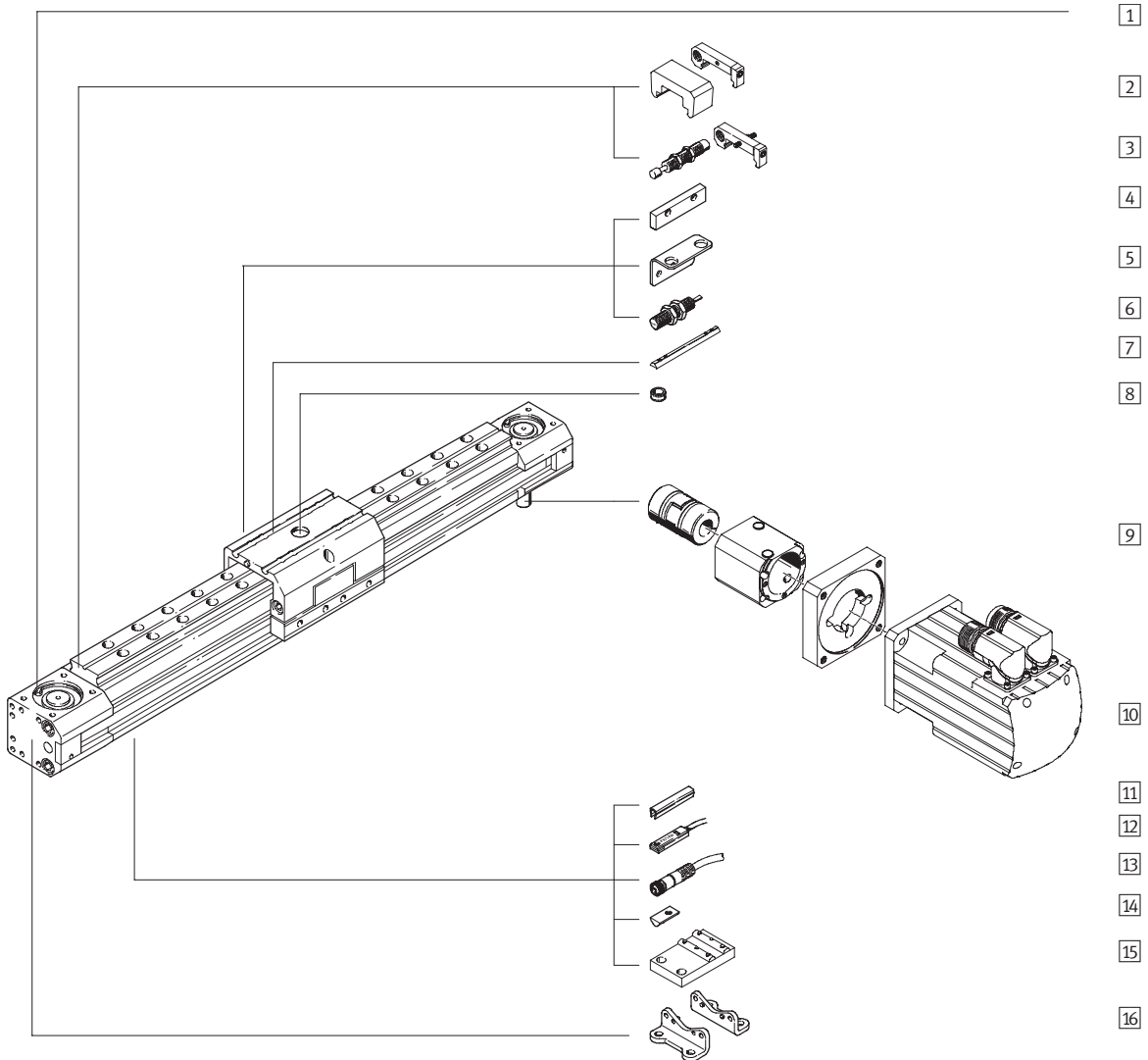
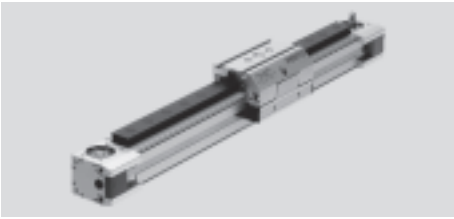

Toothed belt axes DGE-ZR-KF, with recirculating ball bearing guide

Peripherals overview

Variants and accessories				
Type	Brief description	GK/GV	GA	→ Page/Internet
1) Toothed belt axis DGE-ZR-KF	Electromechanical axis with toothed belt and recirculating ball bearing guide	■	■	24
2) Emergency buffer with retainer ¹⁾ A	For avoiding damage at the end stop in the event of malfunction	■	■	82
3) Shock absorber kits C	For avoiding damage at the end stop in the event of malfunction	■	-	81
3) Shock absorber kits E	For avoiding damage at the end stop in the event of malfunction	-	■	82
4) Switching lug L	For sensing the slide position	■	-	84
5) Sensor bracket T	Adapter for mounting the inductive proximity sensors on the axis	■	-	84
6) Inductive proximity sensor O/P/R/W	For use as a proximity signal and safety monitoring	■	-	87
7) Slot nut for slide X	For mounting loads and attachments on the slide	■	■	86
8) Centring pins/sleeves Z	For centring loads and attachments on the slide	■	■	86
9) Axial kit EAMM-A	For axial motor attachment (consisting of: coupling housing, clamping component, motor flange)	■	■	72
10) Motor EMMS	Motors specially matched to the axis, with or without gearing, with or without brake	■	■	72
11) Slot cover B/S	For protecting against the ingress of dirt	■	■	86
12) Proximity sensor G/H/I/J/N	For use as a proximity signal and safety monitoring	■	■	87
13) Cable with socket V	For proximity sensors	■	■	87
14) Slot nut for mounting slot Y	For mounting attachments	■	■	86
15) Central support M	For mounting the axis	■	■	79
16) Foot mounting F	For mounting the axis	■	■	78

1) Fitted as standard for GV and GA

Toothed belt axes DGE-ZR-KF, with recirculating ball bearing guide

Type code

	DGE	-	25	-	500	-	ZR	-	LK	-	RV	-	KF	-	GK	-	KL
Type																	
DGE	Toothed belt drive																
Size																	
Stroke [mm]																	
Drive function																	
ZR	Toothed belt																
Drive shaft on left																	
LK	No drive shaft on left																
LV	Drive shaft on left, front																
LH	Drive shaft on left, rear																
LB	Drive shaft on left, front and rear																
Drive shaft on right																	
RK	No drive shaft on right																
RV	Drive shaft on right, front																
RH	Drive shaft on right, rear																
RB	Drive shaft on right, front and rear																
Guide																	
KF	Recirculating ball bearing guide																
Slide																	
GK	Standard slide																
GV	Extended slide																
GA	Protected version																
Additional slide																	
KL	Left																
KR	Right																

Toothed belt axes DGE-ZR-KF, with recirculating ball bearing guide

Type code

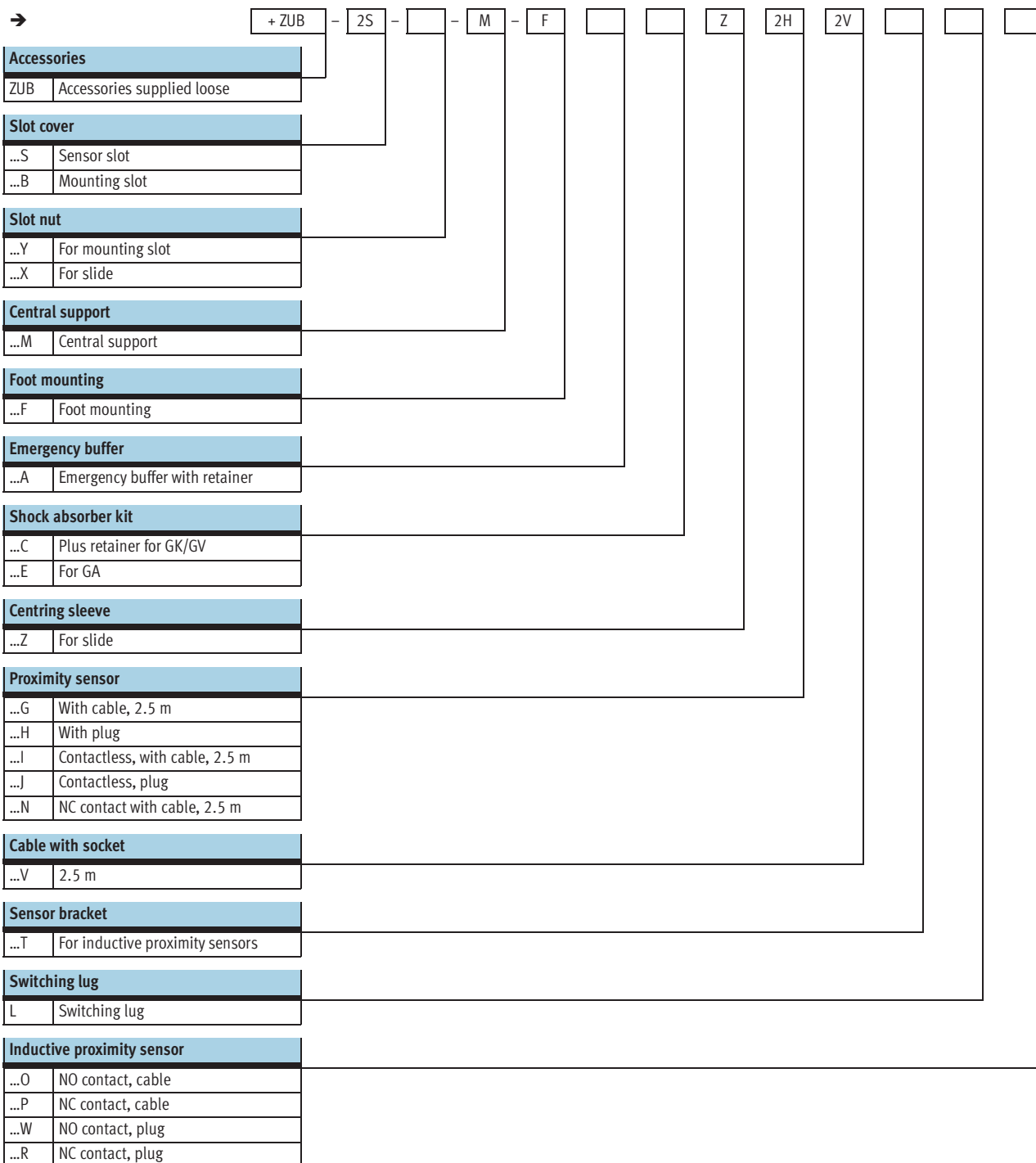

Toothed belt axes DGE-ZR-KF, with recirculating ball bearing guide

FESTO

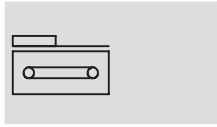

Technical data

Function

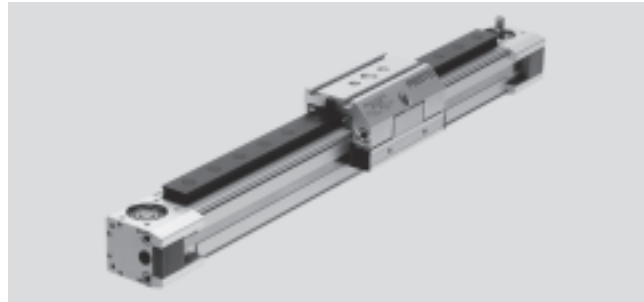

 www.festo.com



-  Size
8 ... 63
-  Stroke length
1 ... 4500 mm

General technical data		8	12	18	25	40	63
Size		8	12	18	25	40	63
Constructional design		Electromechanical axis with toothed belt and recirculating ball bearing guide					
Guide		Recirculating ball bearing guide					
Mounting position		Any					
Max. working stroke ¹⁾	GK [mm]	1 ... 650	1 ... 1000	1 ... 1000	1 ... 3000 ²⁾	1 ... 4000 ²⁾	1 ... 4500 ²⁾
	GV [mm]	–	–	1 ... 920	1 ... 2900	1 ... 3830	1 ... 4250
	GA [mm]	–	–	–	1 ... 1800	1 ... 1800	–
Max. working load	[kg]	1.5	3	6	20	50	120
Max. feed force F_x	[N]	15	30	60	260	610	1500
Max. radial force ³⁾	[N]	103	77	290	307	984	2600
Radial force ⁴⁾	[N]	56	96	117	235	370	840
Radial force ⁵⁾	[N]	40	70	80	140	170	400
Max. driving torque	[Nm]	0.08	0.18	0.5	2.6	9.7	42
Max. no-load driving torque ⁶⁾	[Nm]	0.05	0.08	0.2	0.5	1.0	4.5
Max. speed	[m/s]	1	1.5	2	3	3	3
Max. acceleration	[m/s ²]	15	20	20	50	50	50
Repetition accuracy	[mm]	±0.08			±0.1		

- 1) Total stroke = working stroke + 2x stroke reserve
- 2) Special lengths on request
- 3) On the drive shaft
- 4) On the drive shaft, with a service life of 5,000 km
- 5) On the drive shaft, with a service life of 10,000 km
- 6) Measured at a speed of 0.2 m/s

Operating and environmental conditions		8	12	18	25	40	63
Size		8	12	18	25	40	63
Ambient temperature	[°C]	–10 ... +40					
Protection class		IP40					

Weights [kg]		8	12	18	25	40	63
Basic weight with 0 mm stroke ¹⁾	GK	0.32	0.66	1.16	2.6	7.6	30.3
	GV	–	–	1.62	3.52	9.52	40.2
	GA	–	–	–	3.51	9.67	–
Additional weight per 100 mm stroke	GK/GV	0.095	0.14	0.26	0.47	0.94	2.6
	GA	–	–	–	0.56	1.06	–
Moving load	GK	0,085	0,14	0,32	0,71	1,8	5
	GV	–	–	0,48	0,97	2,52	7,46
	GA	–	–	–	1,27	3,17	–
Additional slide	KL/KR	–	–	0.25	0.38	1.06	3.1

- 1) Including coupling housing and slide

Toothed belt axes DGE-ZR-KF, with recirculating ball bearing guide

Technical data

Mass moment of inertia		8	12	18	25	40	63
Size							
J ₀	GK [kg cm ²]	0.025	0.058	0.247	0.81	5.25	50.7
	GV [kg cm ²]	-	-	0.355	1.08	7.14	70.9
	GA [kg cm ²]	-	-	-	1.37	8.71	-
J _H per metre stroke	[kg cm ² /m]	0.003	0.009	0.021	0.078	0.45	3.6
J _L per kg working load	[kg cm ² /kg]	0.259	0.365	0.685	1	2.53	7.85

The mass moment of inertia J_A of the entire axis is calculated as follows:

$$J_A = J_0 + J_H \times \text{working stroke [m]} + J_L \times m_{\text{working load [kg]}}$$

Toothed belt		8	12	18	25	40	63
Size							
Tensile stress ¹⁾	[%]	0.04	0.1	0.2	0.11	0.1	0.15
Pitch	[mm]	2	2	2	3	5	8
Effective diameter	[mm]	10.18	12.09	16.55	20.05	31.83	56.02
Feed constant	[mm/rev.]	32	38	52	63	100	176

1) At max. feed force

Materials

Sectional view

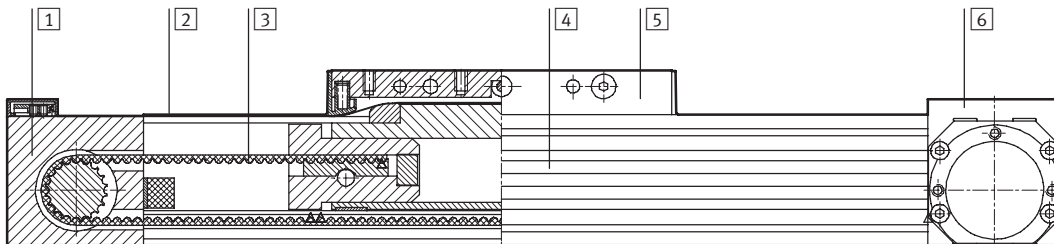

Axis		
1	Return pulley housing	Anodised aluminium
2	Cover strip	Corrosion resistant steel
3	Toothed belt	Polychloroprene with Glascord and nylon coating
4	Profile	Anodised aluminium
5	Slide	Anodised aluminium
6	Drive housing	Anodised aluminium

Toothed belt axes DGE-ZR-KF, with recirculating ball bearing guide

Technical data

Characteristic load values for axis with standard slide GK or protected version GA

The indicated forces and torques refer to the centre of the guide rail. They must not be exceeded in the dynamic range. Special attention must be paid to the cushioning phase.

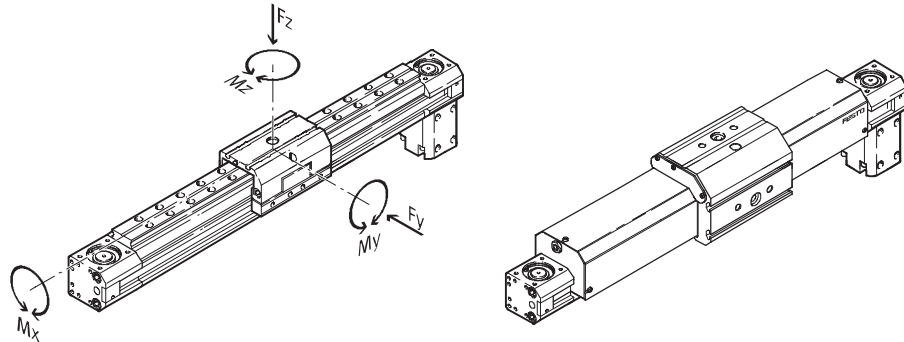

If the axis is subjected to more than two of the indicated forces and torques simultaneously, the following equations must be satisfied in addition to the indicated maximum loads.

$$\frac{F_y}{F_{y_{max}}} + \frac{F_z}{F_{z_{max}}} + \frac{M_x}{M_{x_{max}}} + \frac{M_y}{M_{y_{max}}} + \frac{M_z}{M_{z_{max}}} \leq 1$$

Permissible forces and torques							
Size		8	12	18	25	40	63
F _y _{max.}	[N]	255	565	930	3080	7300	14050
F _z _{max.}	[N]	255	565	930	3080	7300	14050
M _x _{max.}	[Nm]	1	3	7	45	170	580
M _y _{max.}	[Nm]	3.5	9	23	85	330	910
M _z _{max.}	[Nm]	3.5	9	23	85	330	910

2nd moment of area

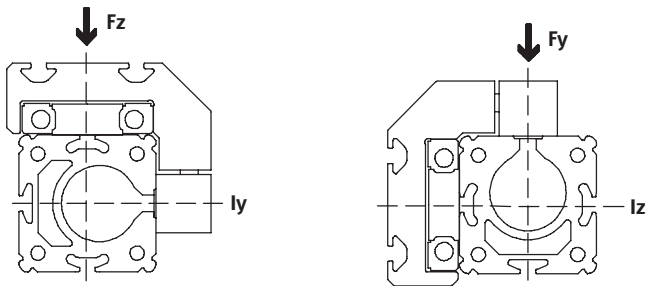

Size		8	12	18	25	40	63
ly	[mm ⁴]	16.9x10 ³	46x10 ³	172x10 ³	551x10 ³	1908x10 ³	13677x10 ³
lz	[mm ⁴]	7x10 ³	21x10 ³	73.7x10 ³	250x10 ³	875x10 ³	6987x10 ³

-  - Note
 Sizing software
 PositioningDrives
 → www.festo.com

Toothed belt axes DGE-ZR-KF, with recirculating ball bearing guide

Technical data

Characteristic load values for axis with extended slide GV

The indicated forces and torques refer to the centre of the guide rail. They must not be exceeded in the dynamic range. Special attention must be paid to the cushioning phase.

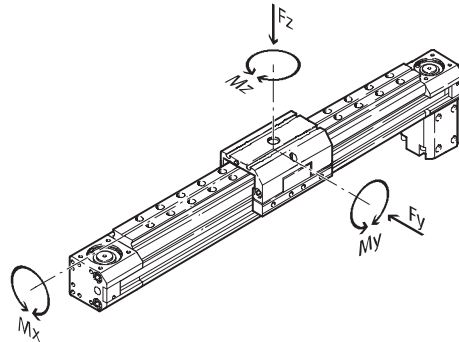

If the axis is subjected to more than two of the indicated forces and torques simultaneously, the following equations must be satisfied in addition to the indicated maximum loads.

$$\frac{F_y}{F_{y_{max}}} + \frac{F_z}{F_{z_{max}}} + \frac{M_x}{M_{x_{max}}} + \frac{M_y}{M_{y_{max}}} + \frac{M_z}{M_{z_{max}}} \leq 1$$

Permissible forces and torques							
Size		8	12	18	25	40	63
F _y _{max.}	[N]	255	565	930	3080	7300	14050
F _z _{max.}	[N]	255	565	930	3080	7300	14050
M _x _{max.}	[Nm]	1	3	7	45	170	580
M _y _{max.}	[Nm]	–	–	45	170	660	1820
M _z _{max.}	[Nm]	–	–	45	170	660	1820

2nd moment of area

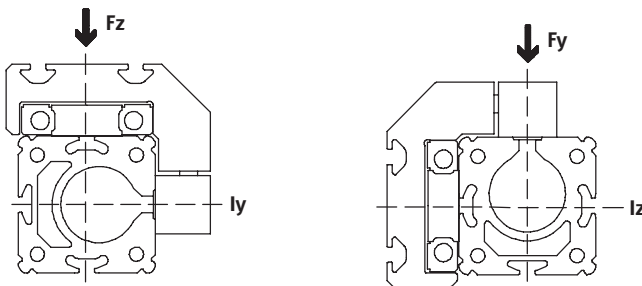

Size		8	12	18	25	40	63
ly	[mm ⁴]	16.9x10 ³	46x10 ³	172x10 ³	551x10 ³	1908x10 ³	13677x10 ³
lz	[mm ⁴]	7x10 ³	21x10 ³	73.7x10 ³	250x10 ³	875x10 ³	6987x10 ³

Toothed belt axes DGE-ZR-KF, with recirculating ball bearing guide

Technical data



Stroke reserve

- L1+ Overall length of axis
- L11 Internal mechanical stop
- L17 Slide length
- 3 Emergency buffer
- 4 Shock absorber retainer

1 The working stroke is the effective usable work range. Please quote this in your order.

L12 Stroke reserve:
Safety distance to mechanical stop, present at both ends of the axis in addition to the stroke.

Example:
Type DGE-25-500-ZR
Working stroke = 500 mm
Stroke reserve = (2x 63 mm) = 126 mm
Total stroke:
626 mm = 500 mm + 126 mm

for standard slide GK

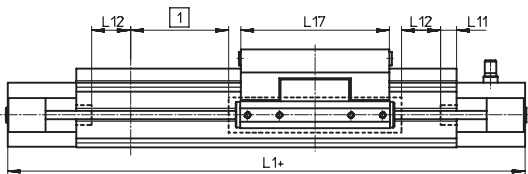

for extended slide GV

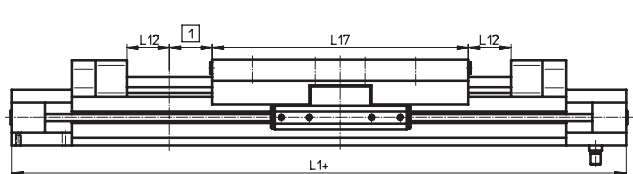

for protected version GA

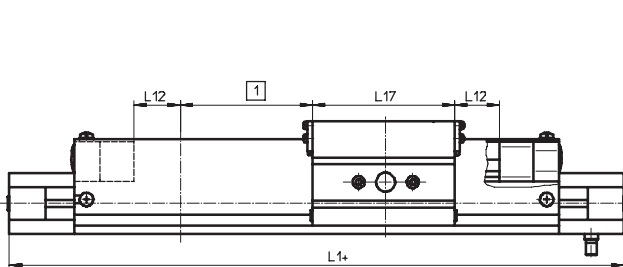

for standard slide GK with optional emergency buffer

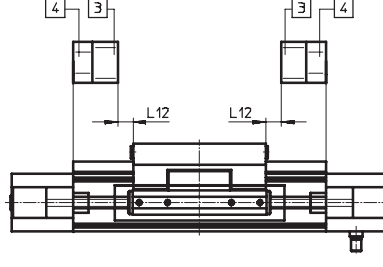

Stroke reserve L12 [mm] per end position

Size Variant	8	12	18	25	40	63
Standard slide GK	27.5	36.5	46.5	63	100	172
Standard slide GK with optional emergency buffer	-	-	23.5	41.5	62	116
Extended slide GV	-	-	23.5	41.5	62	116
Protected version GA	-	-	-	41.5	62	-

Working stroke reduction with standard slide GK or extended slide GV and additional slide KL/KR

- L17 = Slide/additional slide length
- L18 = Distance between both slides
- 4 Additional slide

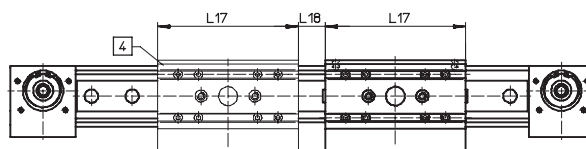

For a toothed belt axis with additional slide, the working stroke is reduced by the length of the additional slide and the distance between both slides.

Example:
Type DGE-25-500-ZR-...-KF-GK-KL
Working stroke without additional slide = 500 mm
L18 = 20 mm
L17 = 105 mm
Working stroke with additional slide = 375 mm
(500 mm - 20 mm - 105 mm)

Toothed belt axes DGE-ZR-KF, with recirculating ball bearing guide

Technical data

Maximum permissible support span l as a function of the force F

The axis may need to be supported with central supports MUP in order to restrict deflection with long stroke lengths. The following diagrams serve to determine the maximum permissible support span l as a function of the force acting upon the axis F .

1] Force on the surface of the slide

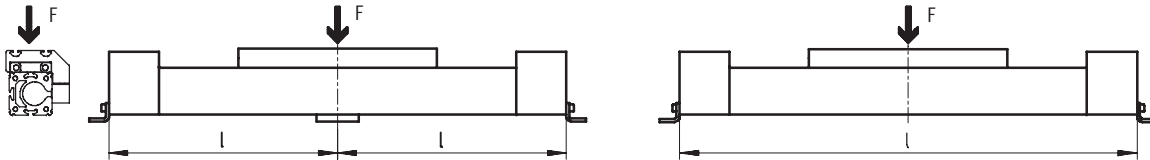

2] Force on the front of the slide

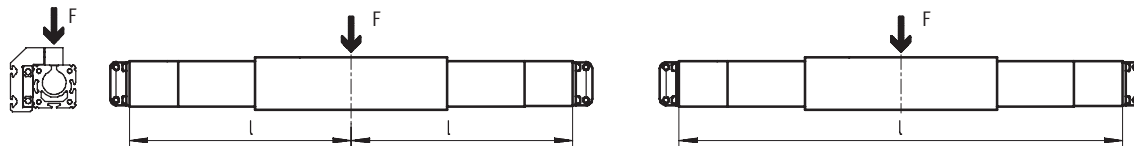

Maximum support span l (without central support) as a function of the force F

DGE-8

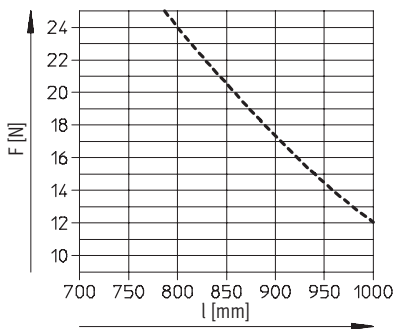

DGE-12

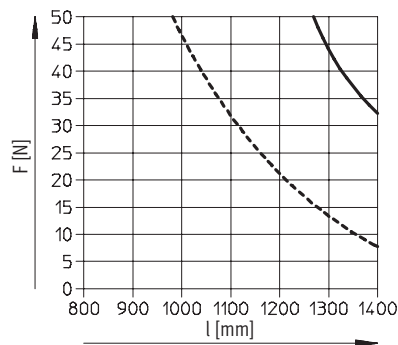

DGE-18

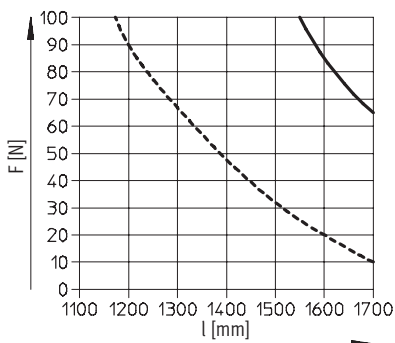

DGE-25

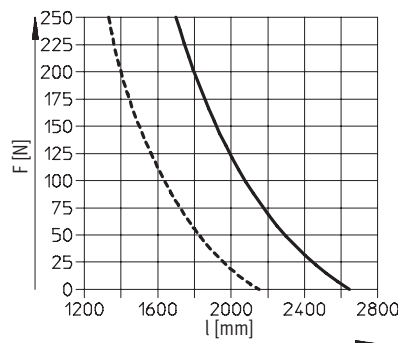

- 1
- - - 2

Toothed belt axes DGE-ZR-KF, with recirculating ball bearing guide

Technical data

Maximum support span l (without central support) as a function of the force F

DGE-40

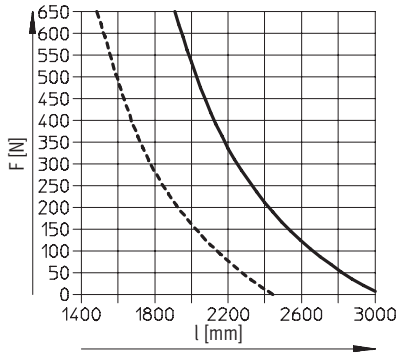

DGE-63

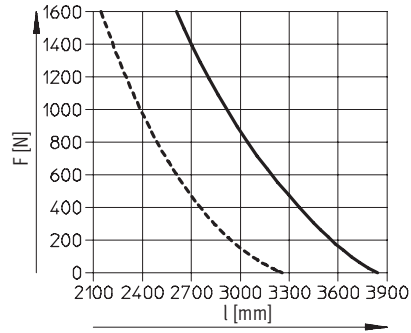

- 1
- - - 2

Toothed belt axes DGE-ZR-KF, with recirculating ball bearing guide

Technical data

Dimensions Download CAD data → www.festo.com

Standard slide GK

Size 8 ... 18

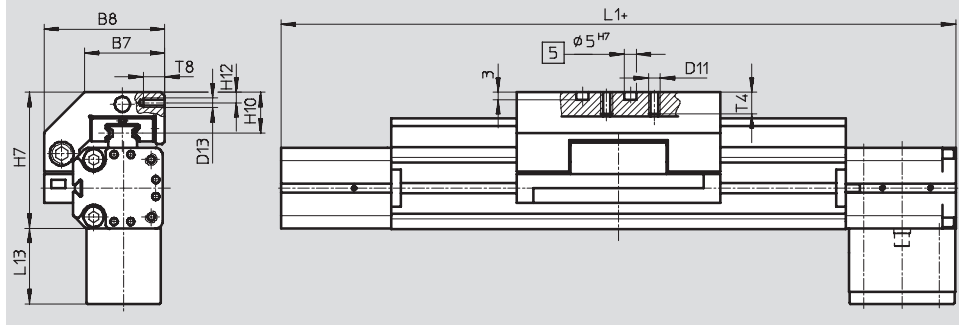

5 Hole for centring pin ZBS-5
+ = plus stroke length

Basic dimensions

→ 14

Stroke reserve

→ 30

Additional slide KL/KR

Size 18

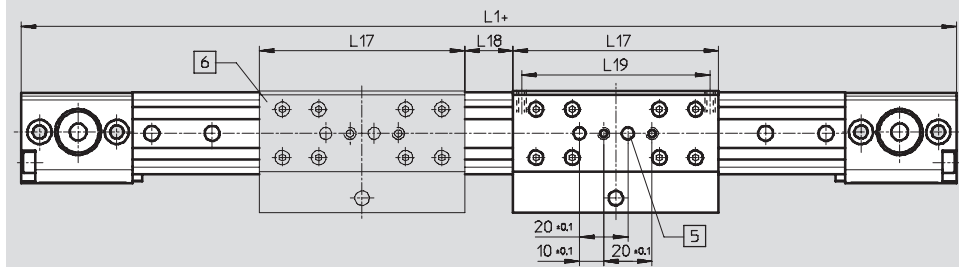

5 Hole for centring pin ZBS-5
6 Additional slide
+ = plus stroke length

Reduction of working stroke

→ 30

Extended slide GV

Size 18

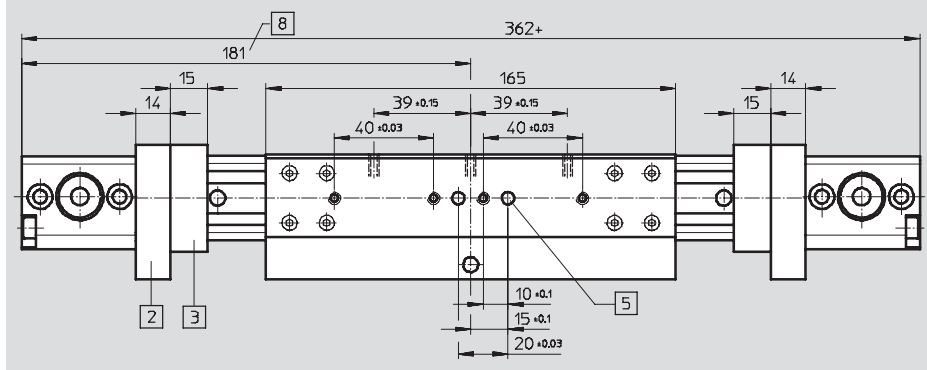

2 Shock absorber retainer KYP
3 Emergency buffer NPE
5 Hole for centring pin ZBS-5
8 Driver in end position of working stroke (stroke reserve up to mechanical stop still present)

+ = plus stroke length

Stroke reserve

→ 30

Profile

Size 8

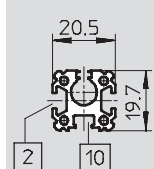

Size 12

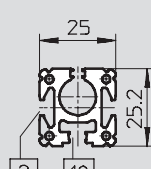

Size 18

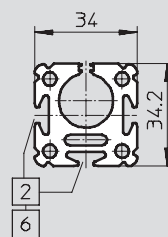

2 Sensor slot for proximity sensor

6 Mounting slot for slot nut NST

10 Not suitable for proximity sensor

Size	B7	B8	D11	D13	H7	H10	H12	L1	L13	L17	L18	L19	T4	T8
8	21.5	32	M4	-	35.5	12	-	180	27.5	52	-	-	7	-
12	22	36.5	M4	-	43.5	14	-	216	29	64	-	-	8.5	-
18	32	50.5	M5	M4	57	17	4.3	282	31.5	85	20	78	10	9

Toothed belt axes DGE-ZR-KF, with recirculating ball bearing guide

Technical data

Dimensions Download CAD data → www.festo.com

Standard slide GK

Size 25 ... 63

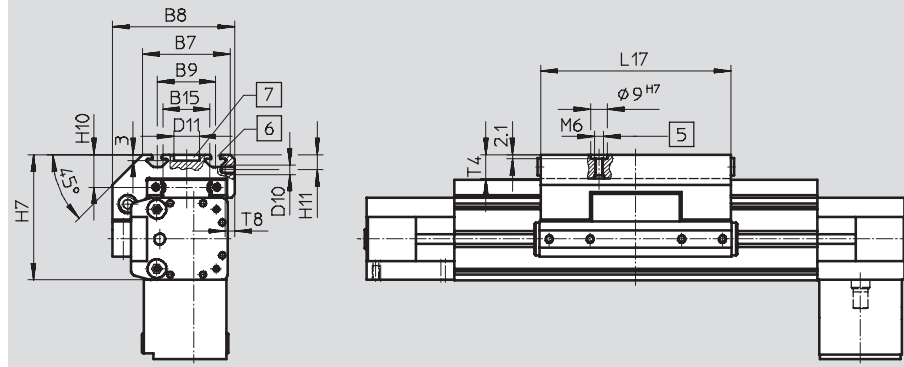

- 5 Hole for centring sleeve ZBH-9
- 6 Mounting slot for slot nut NSTL
- 7 Hole for central mounting SLZZ

Basic dimensions

→ 16

Stroke reserve

→ 30

Size 40/63

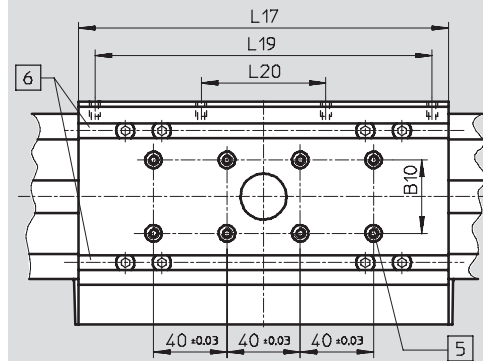

- 5 Hole for centring sleeve ZBH-9
- 6 Mounting slot for slot nut NSTL

Size 25 ... 63

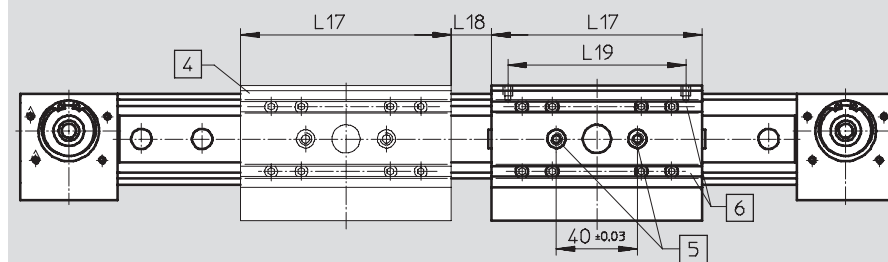

- 4 Additional slide DGE-...-KL/KR
- 5 Hole for centring sleeve ZBH-9
- 6 Mounting slot for slot nut NSTL

Reduction of working stroke

→ 30

Toothed belt axes DGE-ZR-KF, with recirculating ball bearing guide

Technical data

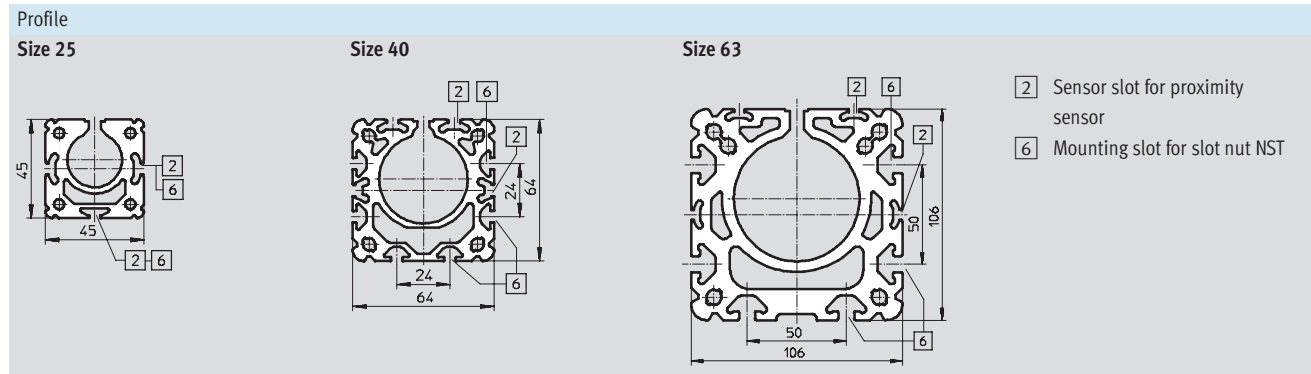

Size	B7	B8	B9	B10	B15	D10	D11	H7
			±0.2				∅ G7	
25	48	67	32	-	23.5	M5	14	68.5
40	78.5	96.5	55	20	42	M5	25	90.5
63	121	142	90	40	71	M8	25	144.5

Size	H10	H11	L17	L18 ¹⁾	L19	L20	T4	T8
					±0.1	±0.1	max.	
25	18.5	8.2	105	20	88	-	12.5	8.5
40	20	7	167	20	150	58	12.5	8.5
63	30	12.5	230	27	200	72	20.5	10.5

1) Recommended minimum distance for access to lubrication nipple.

Toothed belt axes DGE-ZR-KF, with recirculating ball bearing guide

Technical data

Dimensions Download CAD data → www.festo.com

Extended slide GV

Size 25 ... 63

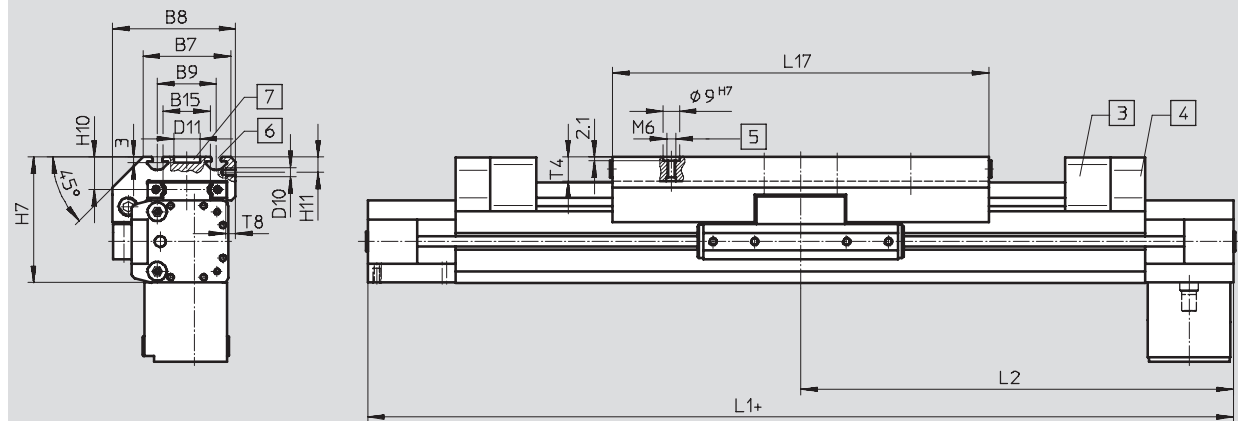

- | | | | |
|--------------------------------------|---|---|------------------|
| 3 Emergency buffer NPE | 5 Hole for centring sleeve ZBH-9 | 7 Hole for central mounting SLZZ | Basic dimensions |
| 4 Shock absorber retainer KYP | 6 Slot for slot nut NSTL | + = plus stroke length | → 16 |
| | | | Stroke reserve |
| | | | → 30 |

Size 25

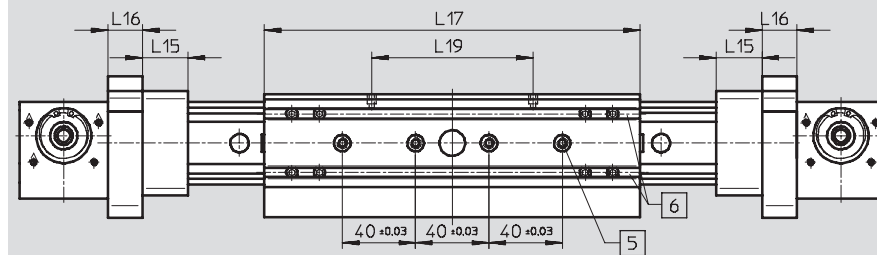

- | |
|---|
| 5 Hole for centring sleeve ZBH-9 |
| 6 Slot for slot nut NSTL |

Size 40/63

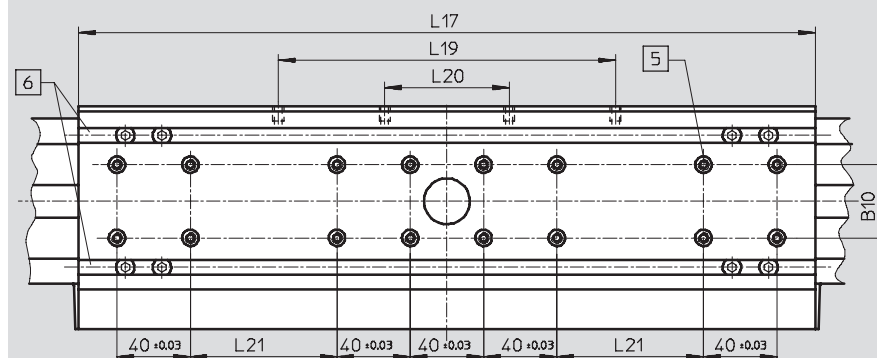

- | |
|---|
| 5 Hole for centring sleeve ZBH-9 |
| 6 Slot for slot nut NSTL |

Toothed belt axes DGE-ZR-KF, with recirculating ball bearing guide

Technical data

Size	B7	B8	B9 ±0.2	B15	D10	D11 ∅ G7	H7	H10	H11
25	48	67	32	23.5	M5	14	68.5	18.5	8.2
40	78.5	96.5	55	42	M5	25	90.5	20	7
63	121	142	90	71	M8	25	144.5	30	12.5

Size	L1	L2	l15	L16	L17 ±0.2	L19 ±0.1	L20 ±0.1	L21 ±0.1	T4 max.	T8
25	472	236	25	19	205	88	–	–	12.5	8.5
40	739	369.5	40	32	337	150	58	40	12.5	8.5
63	1132	566	60	44	480	200	72	120	20.5	10.5

Toothed belt axes DGE-ZR-KF, with recirculating ball bearing guide

Technical data

Dimensions

Download CAD data → www.festo.com

Protected version GA

Size 25

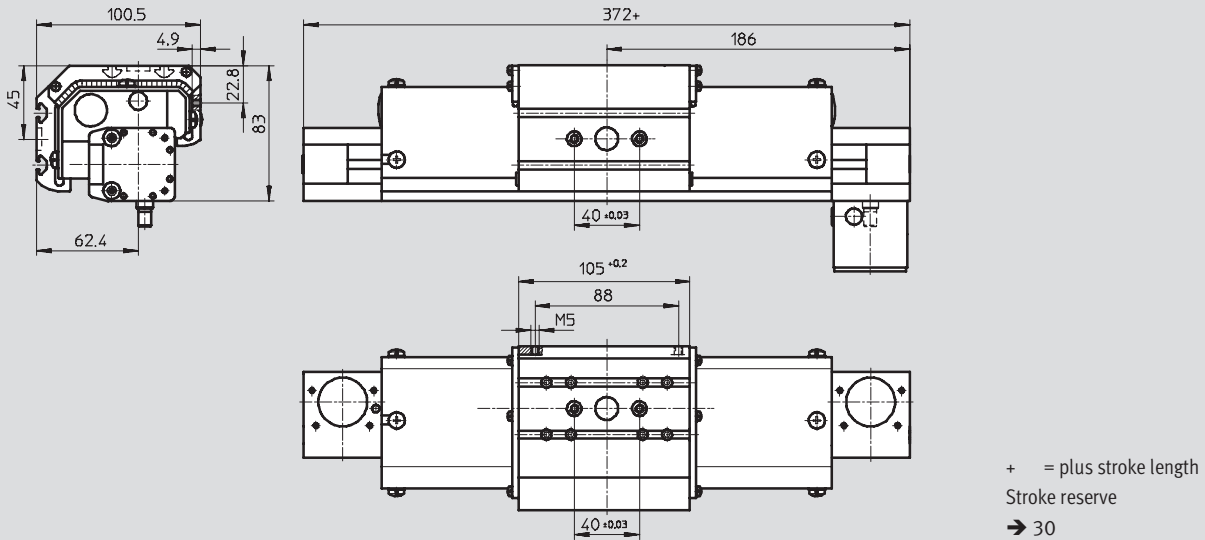

Size 40

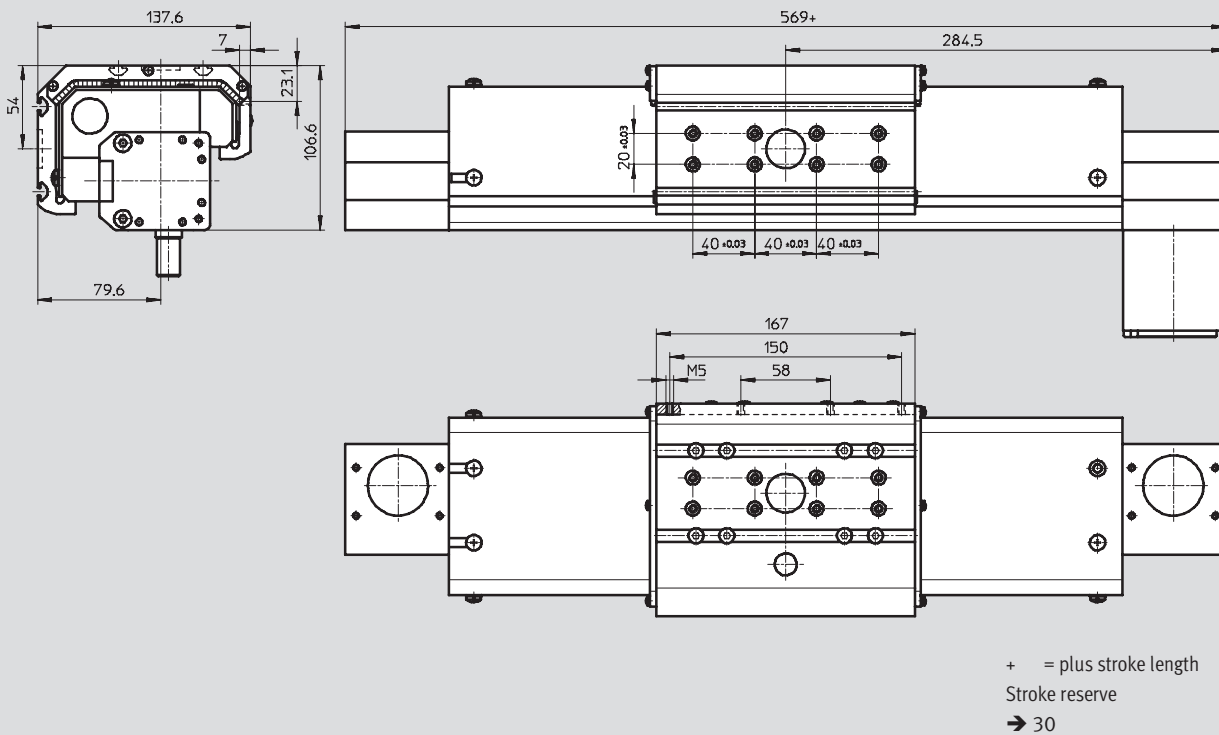

Toothed belt axes DGE-ZR-KF, with recirculating ball bearing guide

Ordering data – Modular products

Order code

Mandatory data

Standard slide GK

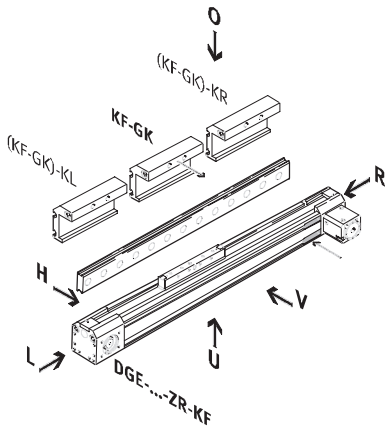

Extended slide GV

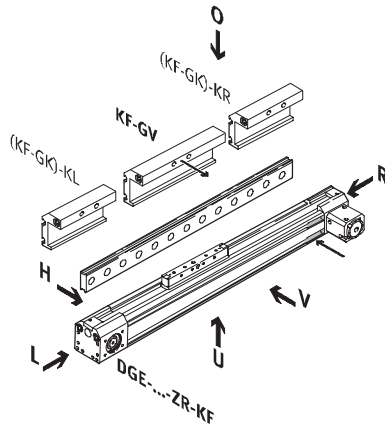

Protected version GA

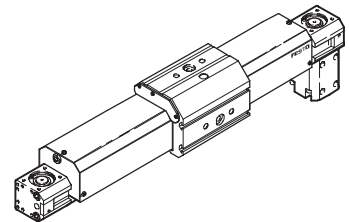

Drive shaft

- LK No drive shaft on left
- LV Drive shaft on left, front
- LH Drive shaft on left, rear
- LB Drive shaft on left, front and rear
- RK No drive shaft on right
- RV Drive shaft on right, front
- RH Drive shaft on right, rear
- RB Drive shaft on right, front and rear

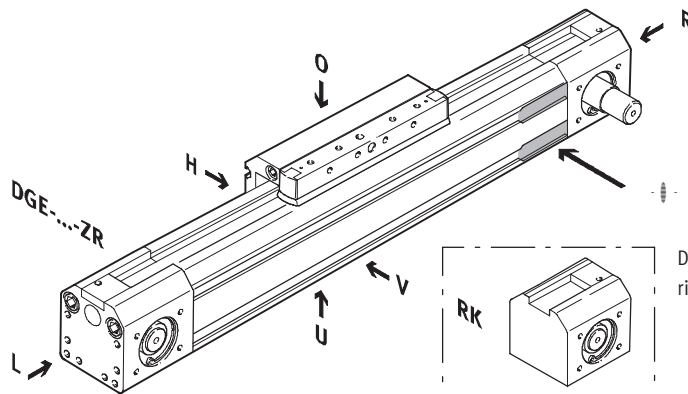

Drive shaft left

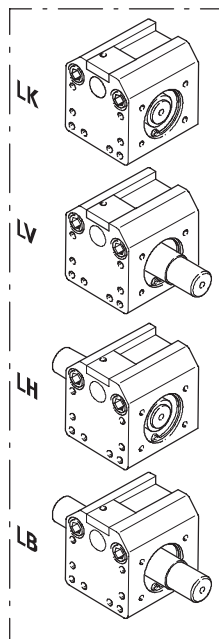

Drive shaft right

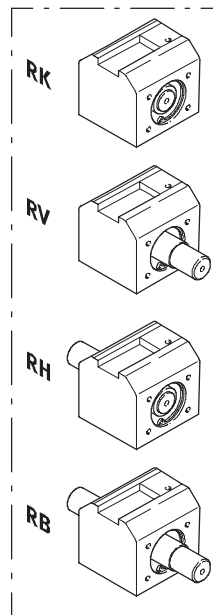

- Note

The insertion point for the proximity sensor is located on the right side of the toothed belt axis

- O top
- U underneath
- R right
- L left
- V front
- H rear

Toothed belt axes DGE-ZR-KF, with recirculating ball bearing guide

Ordering data – Modular products

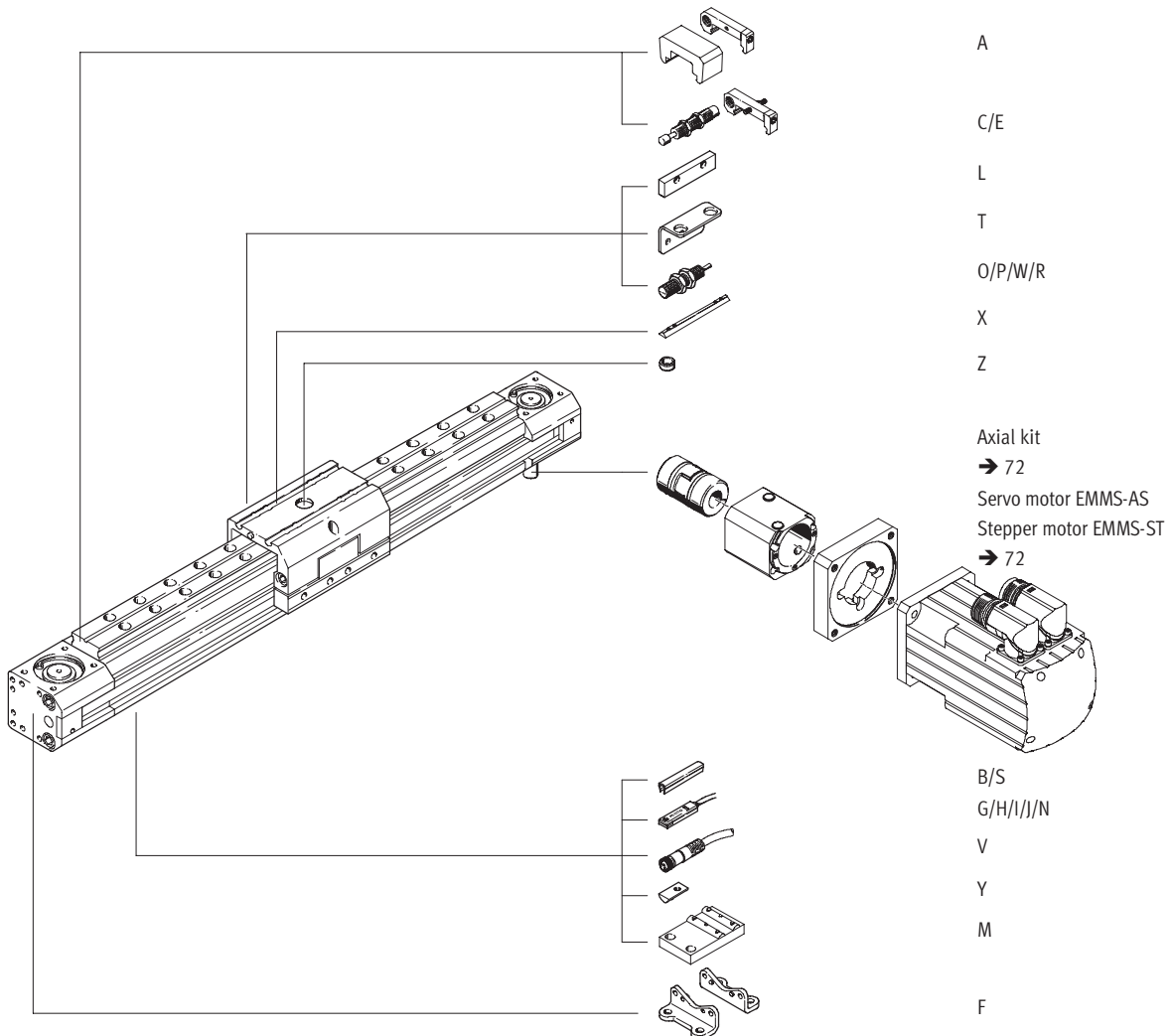

Toothed belt axes DGE-ZR-KF, with recirculating ball bearing guide

Ordering data – Modular products

M Mandatory data →

Module No.	Design	Size	Stroke	Drive function	Drive shaft on left	Drive shaft on right
193 739	DGE	8	1 ... 4500	ZR	LK	RK
193 740		12			LV	RV
193 741		18			LH	RH
193 742		25			LB	RB
193 743		40				
193 744		63				
Ordering example						
193 743	DGE	- 40	- 800	- ZR	- LK	- RV

Ordering table									
Size	8	12	18	25	40	63	Condi- tions	Code	Enter code
M Module No.	193 739	193 740	193 741	193 742	193 743	193 744			
Design	Electromechanical linear axis							DGE	DGE
Size	8	12	18	25	40	63	-...		
Stroke [mm]	1 ... 650	1 ... 1000		1 ... 3000	1 ... 4000	1 ... 4500	[1]	-...	
Drive function	Electromechanical drive with toothed belt							-ZR	-ZR
Drive shaft on left	No drive shaft on left						[2]	-LK	
	Drive shaft on left, front							-LV	
	Drive shaft on left, rear							-LH	
	Drive shaft on left, front and rear							-LB	
Drive shaft on right	No drive shaft on right						[3]	-RK	
	Drive shaft on right, front							-RV	
	Drive shaft on right, rear							-RH	
	Drive shaft on right, front and rear							-RB	

[1] Stroke Special stroke lengths:
 Module No. 8: 1000 mm
 Module No. 12: 1400 mm
 Module No. 18: 1700 mm
 Module No. 25: 5100 mm
 Module No. 40: 4900 mm
 Module No. 63: 4700 mm

[2] LK Not with drive shaft on right RK.
[3] RK Not with drive shaft on left LK.

Transfer order code

DGE - - - **ZR** - -

Toothed belt axes DGE-ZR-KF, with recirculating ball bearing guide

Ordering data – Modular products

Options		
Guide	Slide	Additional slide
KF	GK GV GA	KL KR
- KF	- GK	-

Ordering table											
Size	8	12	18	25	40	63	Condi- tions	Code	Enter code		
0 Guide	Recirculating ball bearing guide						4	-KF	-KF		
	Slide	Standard						5	-GK		
		Extended (maximum stroke for DGE...-ZR-KF-GV)	-	-	Extended (920 mm)	(2 900 mm)	(3 830 mm)	(4 250 mm)	6	-GV	
		Dust protection (maximum stroke for DGE...-ZR-KF-GA)	-	-	-	Dust proof version (1 800 mm)		(1 800 mm)	-	6	-GA
Additional slide	Left (effective stroke reduction)	-	-	Standard slide left (85 mm)		(105 mm)	(167 mm)	(230 mm)	7	-KL	
	Right (effective stroke reduction)	-	-	Standard slide right (85 mm)		(105 mm)	(167 mm)	(230 mm)	7	-KR	

4 **KF** Only with slide GK, GV, GA.
 5 **GK** Emergency buffer recommended → Accessory option "A".

6 **GV,GA** Emergency buffer is scope of delivery
 7 **KL, KR** Only with slide GK or GV.
 Emergency buffer recommended → Accessory option "A".

Transfer order code

- **KF** - -

Toothed belt axes DGE-ZR-KF, with recirculating ball bearing guide

Ordering data – Modular products

Options												
Accessories	Slot cover	Slot nut	Central support	Foot mounting	Emergency buffer and retainer	Shock absorber	Centring sleeve	Proximity sensor	Plug socket	Sensor bracket	Switching lug	Inductive sensor
ZUB	...S ...B	...Y ...X	...M	...F	...A	...C ...E	...Z	...G ...H ...I ...J ...N	...V	...T	...L	...O ...P ...W ...R
ZUB	- 2S2B	10Y2X		F				2I				

Ordering table											
Size	8	12	18	25	40	63	Conditions	Code	Enter code		
Accessories	Supplied separately								ZUB-		ZUB-
Slot cover	Sensor slot	1 ... 10							...S		
	Mounting slot	-	-	-	-	1 ... 10		...B			
Slot nut	for mounting slot	-	-	1 ... 10				...Y			
	for slide	-	-	-	1 ... 10			...X			
Central support	1 ... 10							...M			
Foot mounting (kit)	1 ... 10							...F			
Emergency buffer and retainer for KF	-	-	1 ... 2				[8]	...A			
Shock absorber and retainer for KF-GK, KF-GV	1 ... 2							[9]	...C		
	for KF-GA	-	-	-	1 ... 2	-	[10]	...E			
Centring sleeve (pack of 10)	10, 20, 30, 40, 50, 60, 70, 80, 90							...Z			
Proximity sensor	with cable 2.5 m	1 ... 10							...G		
	with plug	1 ... 10							...H		
	contactless with cable 2.5 m	1 ... 10							...I		
	contactless, plug	1 ... 10							...J		
	NC contact with cable 2.5 m	1 ... 10							...N		
Cable with socket 2.5 m	1 ... 10							...V			
Sensor bracket for inductive sensors	-	-	1 ... 5				[9]	...T			
Switching lug	-	-	1				[9]	L			
Inductive sensor	NO contact, cable	-	-	1 ... 5				[9]	...O		
	NC contact, cable	-	-	1 ... 5				[9]	...P		
	NO contact, plug	-	-	1 ... 5				[9]	...W		
	NC contact, plug	-	-	1 ... 5				[9]	...R		

[8] A Only with slide GK.
Mounted as standard for slide GV, GA

[10] E Only with slide GA.

[9] C, T, L, O, P, W, R
Not with slide GA.

Transfer order code

ZUB -

Toothed belt axes DGE-ZR-RF, with roller guide

Peripherals overview

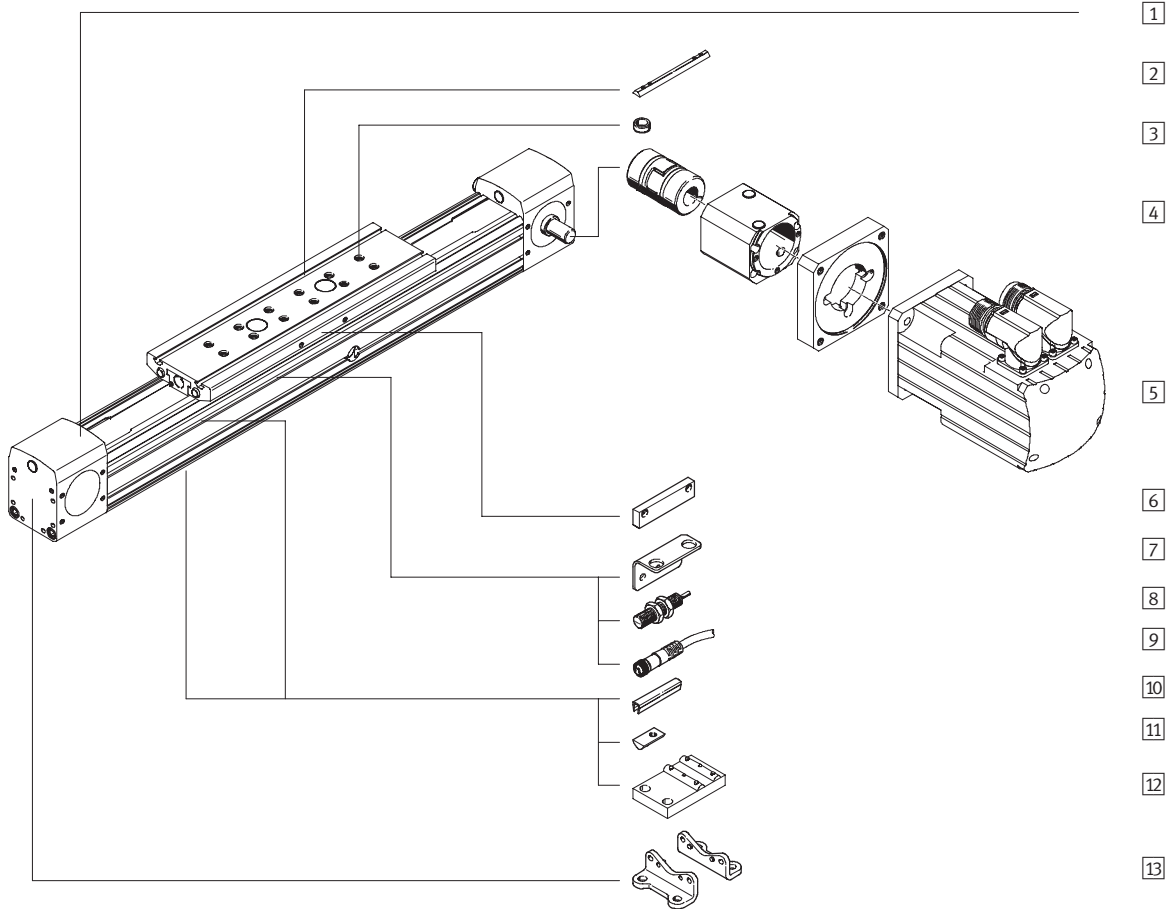

Toothed belt axes DGE-ZR-RF, with roller guide

Peripherals overview

Variants and accessories		
Type	Brief description	→ Page/Internet
1 Toothed belt axis DGE-RF	Electromechanical axis with roller guide	48
2 Slot nut for slide X	For mounting loads and attachments on the slide	86
3 Centring sleeve Z	For centring loads and attachments on the slide	86
4 Axial kit EAMM-A	For axial motor attachment (consisting of: coupling housing, clamping component, motor flange)	72
5 Motor EMMS	Motors specially matched to the axis, with or without gearing, with or without brake	72
6 Switching lug L	For sensing the slide position	84
7 Sensor bracket T	Adapter for mounting the sensors on the axis	84
8 Inductive proximity sensor O/P/W/R	For use as a proximity signal and safety monitor	87
9 Cable with socket V	For proximity sensors	87
10 Slot cover B	For protecting against the ingress of dirt	86
11 Slot nut for profile slot Y	For mounting attachments	86
12 Central support M	For mounting the axis	79
13 Foot mounting F	For mounting the axis	78

Toothed belt axes DGE-ZR-RF, with roller guide

Type code

		DGE	-	25	-	500	-	ZR	-	RF	-	LK	-	RV	-	GK
Type																
DGE	Toothed belt drive															
Size																
Stroke [mm]																
Drive function																
ZR	Toothed belt															
Guide																
RF	Roller guide															
Drive shaft on left																
LK	No drive shaft on left															
LV	Drive shaft on left, front															
LH	Drive shaft on left, rear															
LB	Drive shaft on left, front and rear															
Drive shaft on right																
RK	No drive shaft on right															
RV	Drive shaft on right, front															
RH	Drive shaft on right, rear															
RB	Drive shaft on right, front and rear															
Slide																
GK	Standard slide															
GV	Extended slide															

Toothed belt axes DGE-ZR-RF, with roller guide

Type code

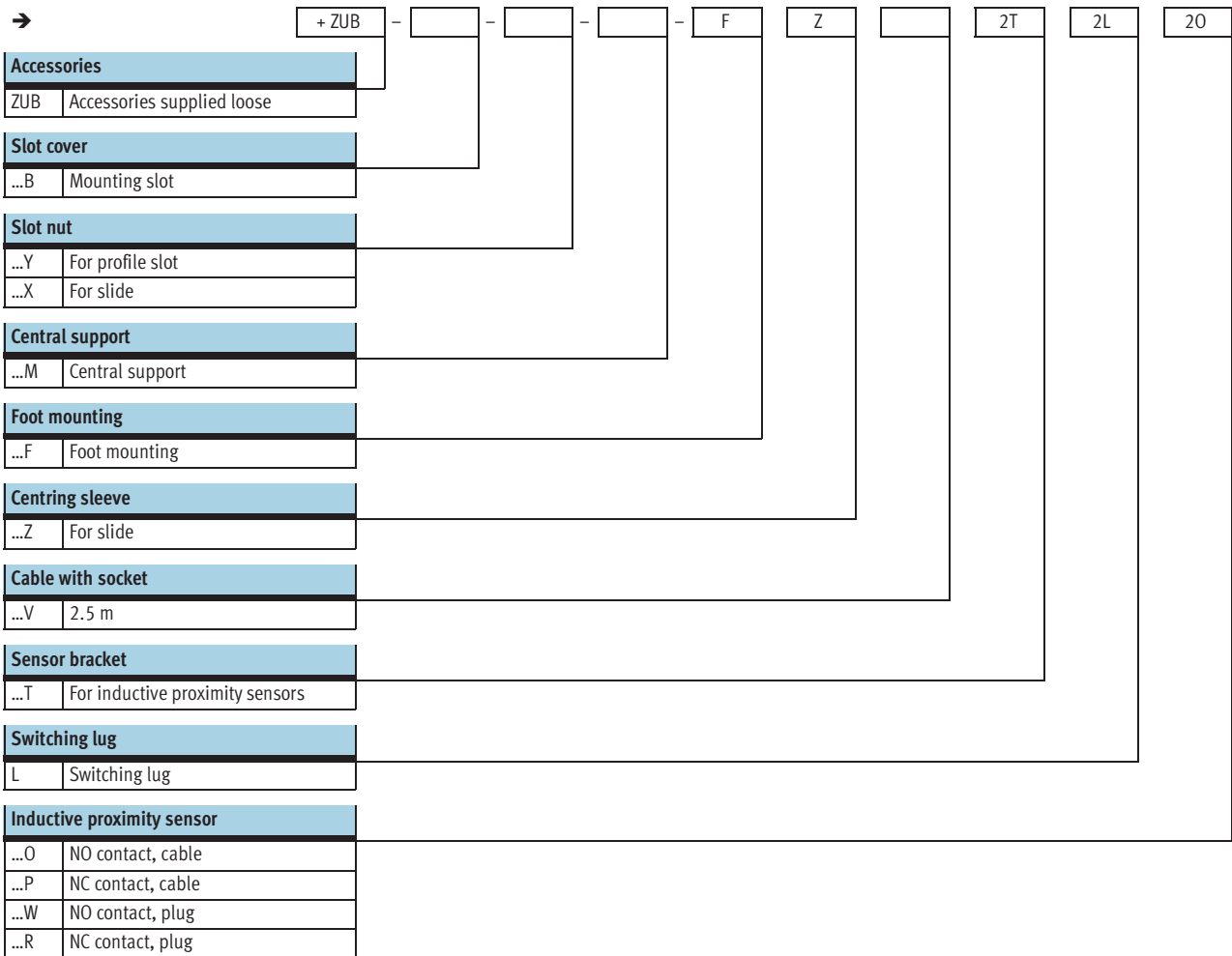

Toothed belt axes DGE-ZR-RF, with roller guide

Technical data

Function

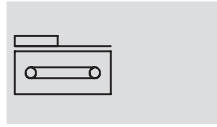

- - Size
25, 40 and 63
- - Stroke length
1 ... 5000 mm



General technical data				
Size		25	40	63
Constructional design		Electromechanical axis with toothed belt and internal roller guide		
Guide		Internal roller guide		
Mounting position		Any		
Max. working stroke ¹⁾	[mm]	1 ... 5000	1 ... 5000	1 ... 5000 ²⁾
Max. working load	[kg]	15	30	60
Max. feed force F_x	[N]	260	610	1500
Max. radial force ³⁾	[N]	260	935	2490
Radial force ⁴⁾	[N]	110	100	1050
Max. driving torque	[Nm]	3.7	12.1	55.38
Max. no-load torque	[Nm]	0.5	1.0	4.5
Max. speed	[m/s]	10		
Max. acceleration	[m/s ²]	50	50	50
Repetition accuracy	[mm]	±0.1		

- 1) Total stroke = working stroke + 2x stroke reserve
- 2) In the case of the variant with extended slide (-GV), the maximum working stroke is 4,800 mm
- 3) On the drive shaft
- 4) On the drive shaft, with a service life of 10,000 km

Operating and environmental conditions				
Size		25	40	63
Ambient temperature	[°C]	0 ... +60		
Protection class		IP40		

Weights [kg]						
Size	25		40		63	
	GK	GV	GK	GV	GK	GV
Basic weight with 0 mm stroke	2.61	3.15	7.75	9.32	29.81	34.91
Additional weight per 100 mm stroke	0.30		0.61		1.44	
Moving load	0,62	0,85	2,00	2,70	5,20	7,00

Mass moment of inertia							
Size	25		40		63		
	GK	GV	GK	GV	GK	GV	
J_0	[kg cm ²]	1.75	2.75	9.89	15.37	108.11	156.71
J_H per metre stroke	[kg cm ² /m]	0.188		0.933		7.605	
J_L per kg working load	[kg cm ² /kg]	2.052		3.958		13.634	

The mass moment of inertia J_A of the entire axis is calculated as follows:

$$J_A = J_0 + J_H \times \text{working stroke [m]} + J_L \times m_{\text{working load [kg]}}$$

Toothed belt axes DGE-ZR-RF, with roller guide

Technical data

Toothed belt				
Size		25	40	63
Tensile stress ¹⁾	[%]	0.16	0.11	0.15
Pitch	[mm]	3	5	8
Effective diameter	[mm]	28.65	39.79	73.85
Feed constant	[mm]	90	125	232

1) At max. feed force

Materials

Sectional view

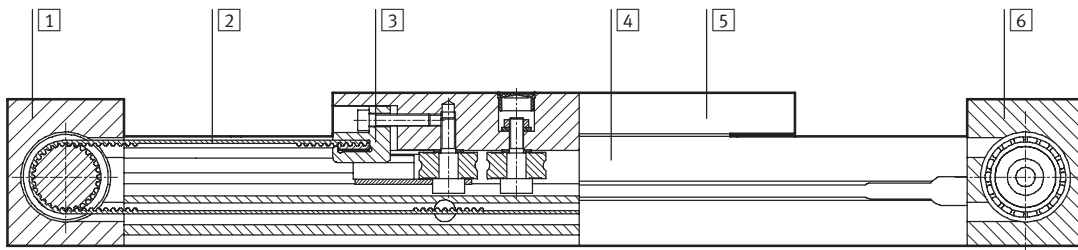

Axis		
1	Return pulley housing	Anodised aluminium
2	Toothed belt	Polychloroprene with Glascord and nylon coating
3	Clamping component	Special steel casting
4	Profile	Anodised aluminium
5	Slide	Anodised aluminium
6	Drive housing	Anodised aluminium

Stroke reserve

- L9 Stroke reserve:
Safety distance to mechanical stop, present at both ends of the axis in addition to the stroke.
- L6 Slide length
- L8 Stop element
- L1+ Overall length of axis
- 1 Working stroke

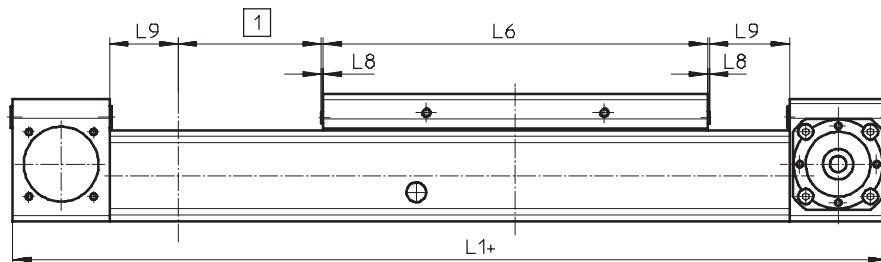

Example:
Type DGE-25-500-ZR-RF

Working stroke = 500 mm
 Stroke reserve = (2x 63 mm)
 = 126 mm
 Total stroke = 500 mm + 126 mm
 = 626 mm

Stroke reserve L9 [mm] per end position			
Size	25	40	63
Standard slide GK	63	100	172
Extended slide GV	63	100	172

Toothed belt axes DGE-ZR-RF, with roller guide

Technical data



Characteristic load values

The indicated forces and torques refer to the centre of the guide. They must not be exceeded in the dynamic range. Special attention must be paid to the cushioning phase.

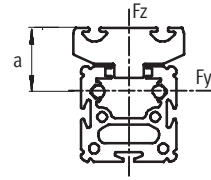
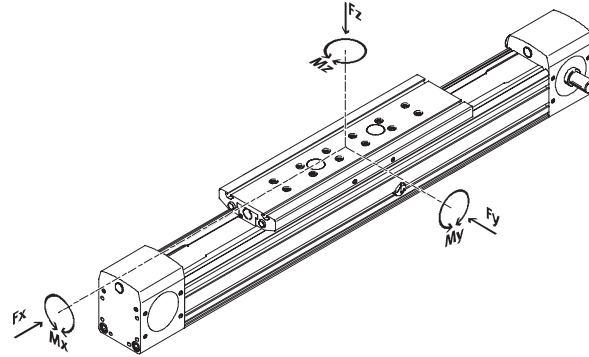

Distance a with:
 DGE-25: 30 mm
 DGE-40: 37 mm
 DGE-63: 44.6 mm

If the drive is subjected to more than two of the indicated forces and torques simultaneously, the following equations must be satisfied in addition to the indicated maximum loads.

$$\frac{F_y}{F_{y_{max}}} + \frac{F_z}{F_{z_{max}}} + \frac{M_x}{M_{x_{max}}} + \frac{M_y}{M_{y_{max}}} + \frac{M_z}{M_{z_{max}}} \leq 1$$

Permissible forces and torques

Size	25		40		63	
	GK	GV	GK	GV	GK	GV
$F_{x_{max}}$ [N]	260		610		1500	
$F_{y_{max}}$ [N]	150		300		600	
$F_{z_{max}}$ [N]	150		300		600	
$M_{x_{max}}$ [Nm]	7		18		65	
$M_{y_{max}}$ [Nm]	15	30	60	120	170	340
$M_{z_{max}}$ [Nm]	15	30	90	180	300	600

2nd moment of area

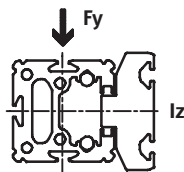
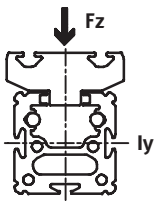

Size	25	40	63
I_y [mm ⁴]	1.88x10 ⁵	7.03x10 ⁵	4.75x10 ⁶
I_z [mm ⁴]	2.36x10 ⁵	9.463x10 ⁵	5.997x10 ⁶

- - Note

Sizing software
 PositioningDrives
www.festo.com

Toothed belt axes DGE-ZR-RF, with roller guide

Technical data

Maximum permissible support span l as a function of the applied load m

The axis may need to be supported with central supports MUP in order to restrict deflection with long stroke lengths. The following diagrams serve

to determine the maximum permissible support span as a function of the applied load acting upon the axis.

A distinction is made here between forces acting upon the surface of the slide and forces acting upon the front of the slide.

1 Load on the surface of the slide

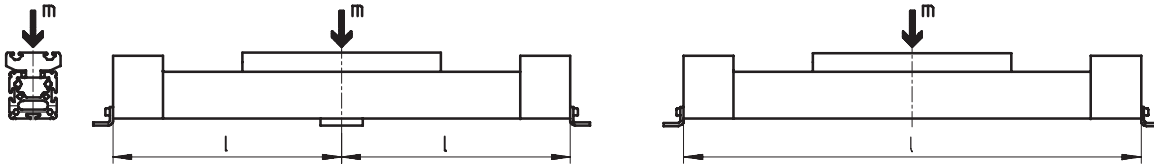

2 Load on the front of the slide

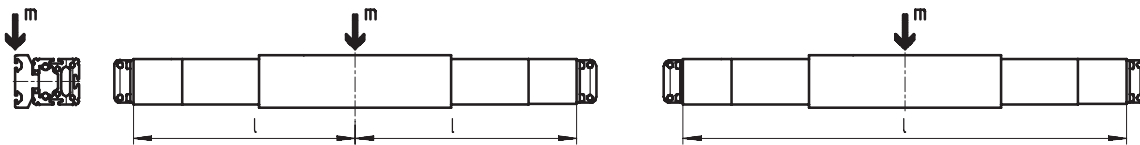

Maximum support span l (without central support) as a function of the applied load m

DGE-25-RF

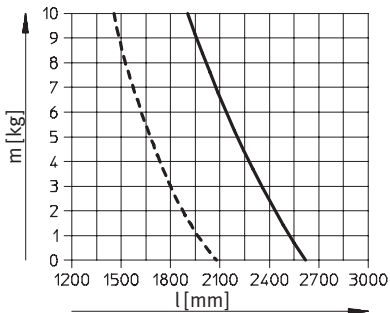

DGE-40-RF

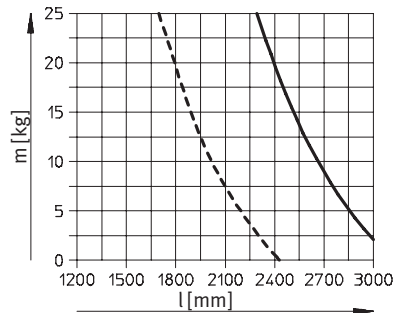

DGE-63-RF

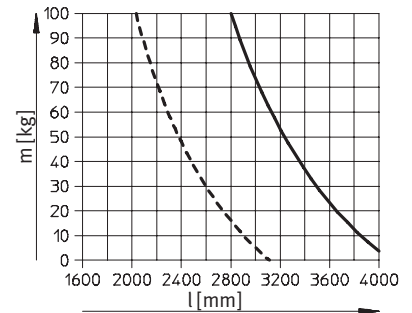

- 1
- - - 2

Toothed belt axes DGE-ZR-RF, with roller guide

Technical data

FESTO

Dimensions

Download CAD data → www.festo.com

DGE-25/-40/-63

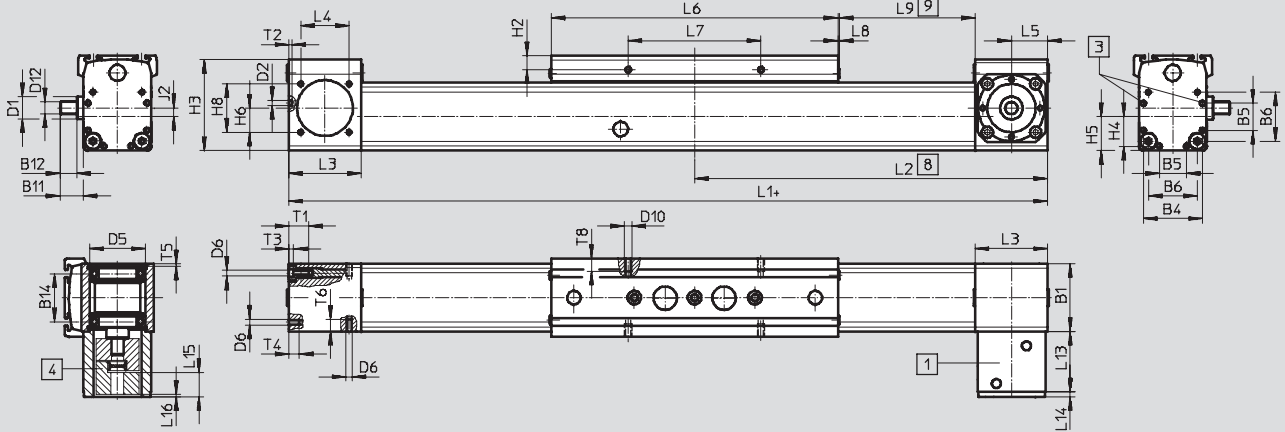

DGE-25

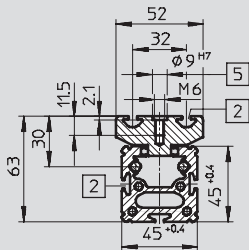

DGE-40

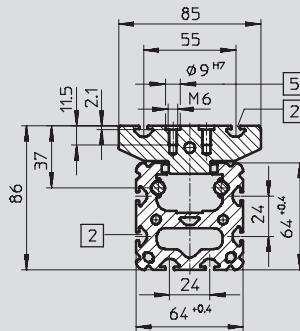

DGE-63

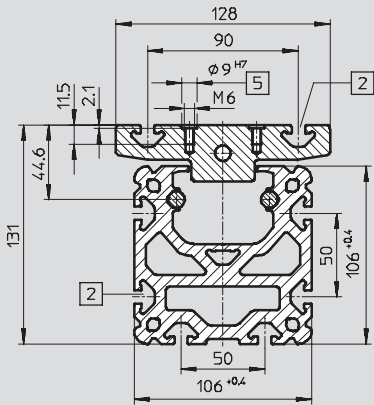

DGE-25-GK

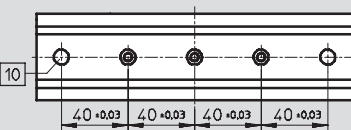

DGE-40-GK

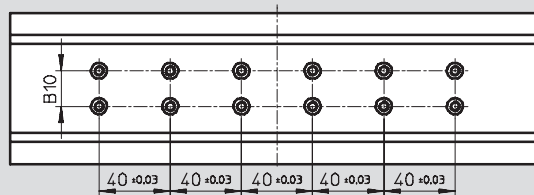

- | | | | |
|-----------------------------------|--|---|-----------------------------------|
| 1 Coupling housing | 4 Coupling | 8 Driver in end position of working stroke (stroke reserve up to mechanical stop still present) | 9 Stroke reserve → 49 |
| 2 Slot for slot nuts | 5 Hole for centring sleeve ZBH-9 and mounting thread | | 10 Hole for centring sleeve ZBH-9 |
| 3 Centring hole for foot mounting | | | + = plus stroke length |

Toothed belt axes DGE-ZR-RF, with roller guide

Technical data

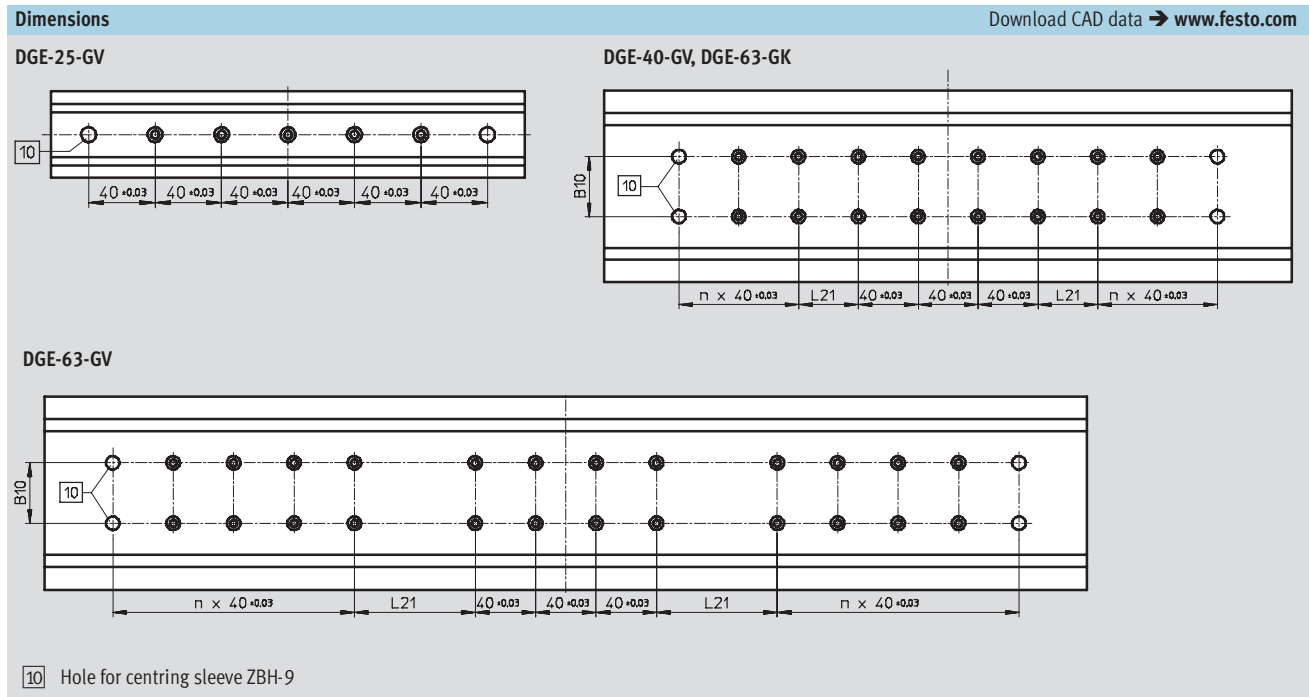

Size		B1	B4	B5	B6	B10 ±0.03	B11	B12	B14	D1 ∅	D2	D5 H7	D6	D10	D12 ∅ h6
25	GK	45	39.1	18	32.5	-	15.6	11	31.8	15	3.3 _{+0.1}	37	M4	M5	8
	GV														
40	GK	64	53	28	49	20	29.6	24.5	45.5	20	4.4 _{H13}	47	M5	M5	15
	GV														
63	GK	106	89	44	83	40	41.1	35.2	74.3	35	6.4 _{+0.1}	80	M8	M8	25
	GV														

Size		H2	H3	H4	H5	H6	H8	J2	L1	L2	L3	L4	L5	L6	L7
25	GK	9.3	60.4	19.6	22.5	16	32	5.8	414	207	48	32	24	190	88
	GV								509	254.5				285	
40	GK	9.5	83.8	26.5	32	19.5	30	8.8	638	319	67	54	34	300	58
	GV								778	389				440	
63	GK	10.5	129.3	44.5	52.8	27.5	49	10.1	1020	510	106	84	55	460	72
	GV								1250	625				690	

Size		L8	L9	L13	L14	L15	L16	L21 ±0.03	n	T1	T2	T3	T4	T5	T6	T8
25	GK	1	63	40	3,2	14,6	3,6	-	-	10	2	3	7	< 1.6	8	8.5
	GV															
40	GK	2	100	65	4	22,8	-2,2	40	-	12	3	5	12	< 2.9	12	8.5
	GV								2							
63	GK	2	172	91	5	35	0	40	2	21	4	6.5	22	< 5.1	15	12
	GV							80	4							

Toothed belt axes DGE-ZR-RF, with roller guide

Ordering data – Modular products

Order code

Mandatory data

GK Standard slide

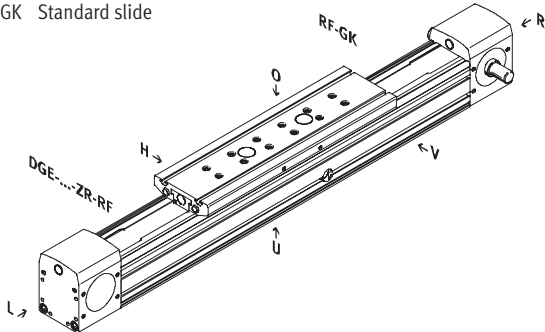

GV Extended slide

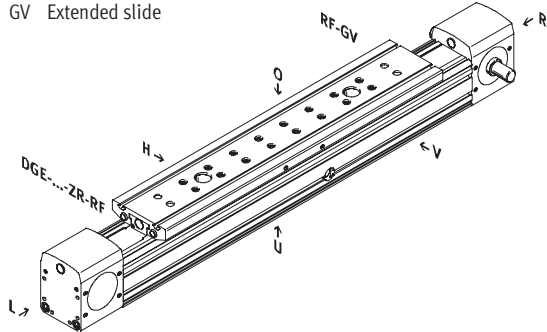

Drive shaft

- LK No drive shaft on left
- LV Drive shaft on left, front
- LH Drive shaft on left, rear
- LB Drive shaft on left, front and rear
- RK No drive shaft on right
- RV Drive shaft on right, front
- RH Drive shaft on right, rear
- RB Drive shaft on right, front and rear

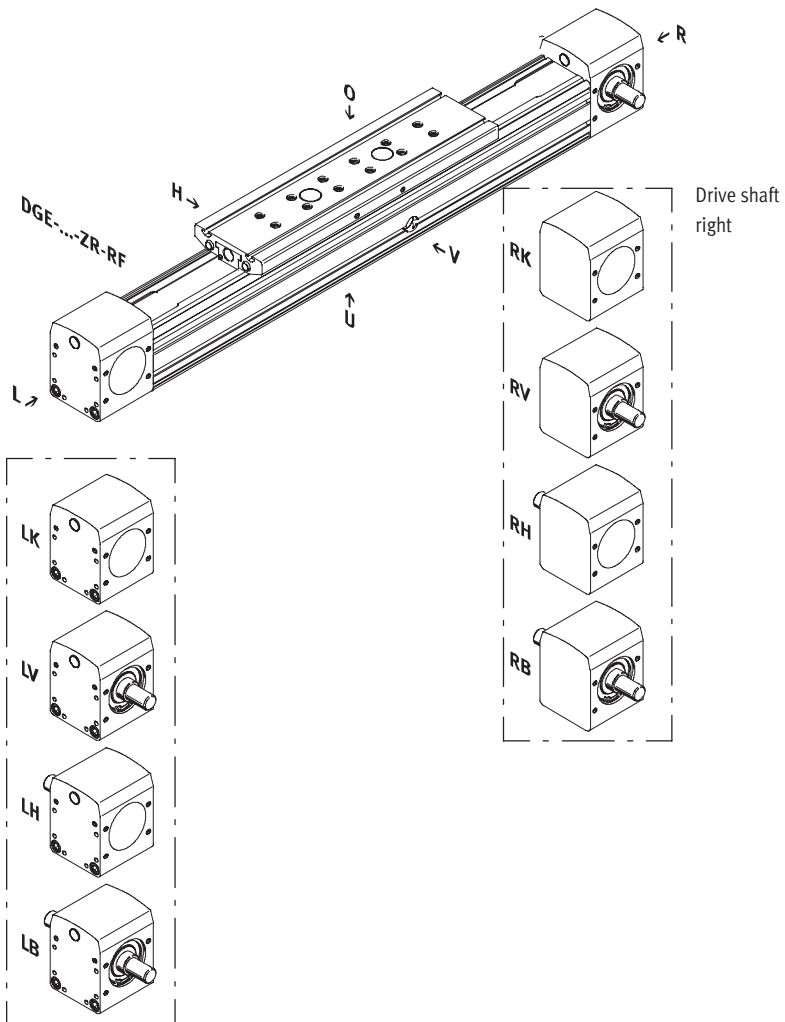

- O top
- U underneath
- R right
- L left
- V front
- H rear

Toothed belt axes DGE-ZR-RF, with roller guide

Ordering data – Modular products

Order code

Options

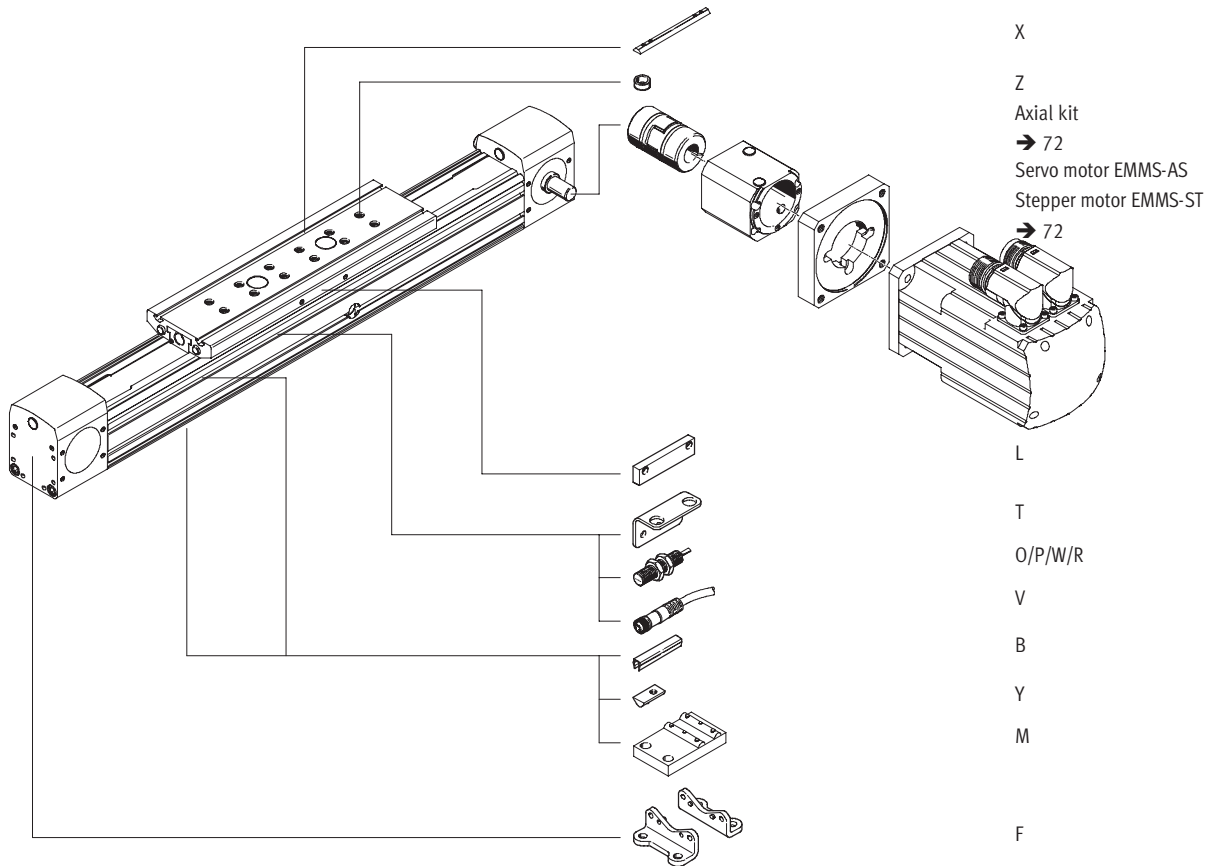

Toothed belt axes DGE-ZR-RF, with roller guide

Ordering data – Modular products

M Mandatory data →

Module No.	Design	Size	Stroke	Drive function	Guide	Drive shaft on left	Drive shaft on right	Slide
534 391	DGE	25	1 ... 5 000	ZR	RF	LK	RK	GK
534 392		40				RV	GV	
534 393		63				LH	RH	
						LB	RB	
Ordering example								
534 391	DGE	- 25	- 600	- ZR	- RF	- LK	- RV	- GK

Ordering table							
Size	25	40	63	Condi- tions	Code	Enter code	
M Module No.	534 391		534 392	534 393			
Design	Electromechanical linear drive				DGE		DGE
Size	25	40	63		-...		
Stroke [mm]	1 ... 5000		1 ... 5000	1 ... 5000		-...	
Drive function	Electromechanical drive with toothed belt				-ZR		-ZR
Guide	Roller guide				-RF		-RF
Drive shaft on left	No drive shaft on left			[1]	-LK		
	Drive shaft on left, front				-LV		
	Drive shaft on left, rear				-LH		
	Drive shaft on left, front and rear				-LB		
Drive shaft on right	No drive shaft on right			[2]	-RK		
	Drive shaft on right, front				-RV		
	Drive shaft on right, rear				-RH		
	Drive shaft on right, front and rear				-RB		
Slide	Standard slide				-GK		
	Extended slide			[3]	-GV		

- [1] LK Not with drive shaft on right RK.
- [2] RK Not with drive shaft on left LK.

- [3] GV Maximum stroke: Size 63: 4800 mm

Transfer order code

Toothed belt axes DGE-ZR-RF, with roller guide

Ordering data – Modular products

Options									
Accessories	Slot cover		Central support		Centring pins/sleeves		Sensor bracket		Inductive sensor
ZUB	Slot nut		Foot mounting		Plug socket		Switching lug		
	...B	...Y ...X	...M	...F	...Z	...V	...T	L	...O ...P ...W ...R
ZUB		2X					2T		20 2P

Ordering table							
Size	25	40	63	Condi- tions	Code	Enter code	
0	Accessories			Supplied separately		ZUB-	ZUB-
	Slot cover for mounting slot			1 ... 10		...B	
	Slot nut for profile slot			1 ... 10		...Y	
	Slot nut for slide			1 ... 10		...X	
	Central support			1 ... 10		...M	
	Foot mounting (kit)			1 ... 10		...F	
	Centring sleeve (pack of 10)			10, 20, 30, 40, 50, 60, 70, 80, 90		...Z	
	Cable with socket, 2.5 m			1 ... 10		...V	
	Sensor bracket for inductive sensors			1 ... 5		...T	
	Switching lug			1		L	
	Inductive proximity sensor	NO contact with cable		1 ... 5		...O	
		NC contact with cable		1 ... 5		...P	
		NO contact with plug		1 ... 5		...W	
		NC contact with plug		1 ... 5		...R	

Transfer order code

ZUB -

Toothed belt axes DGE-ZR-HD, with heavy-duty guide

Peripherals overview

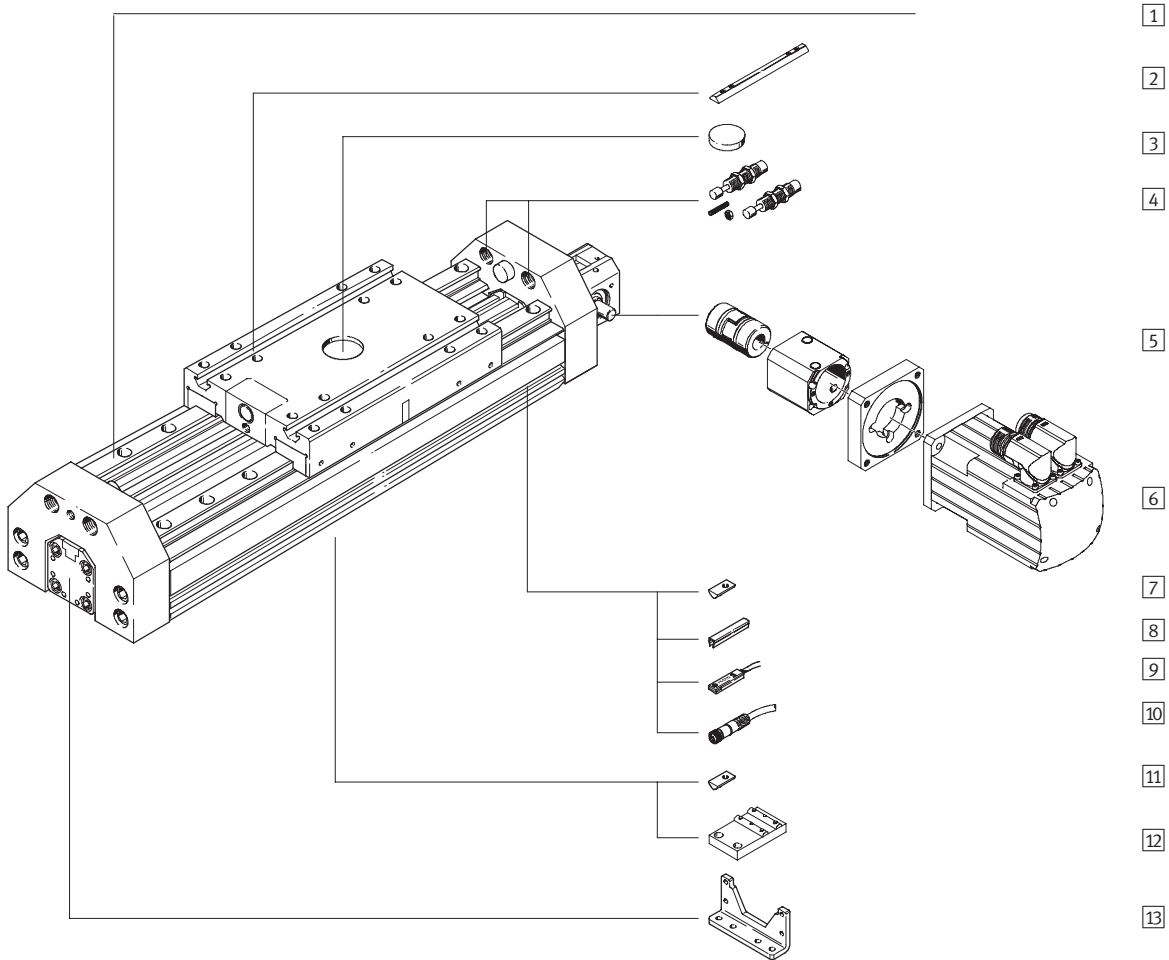
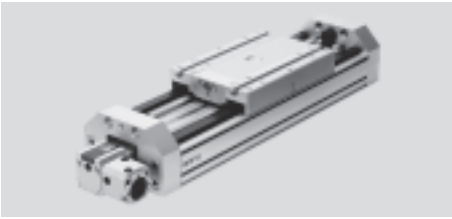

Toothed belt axes DGE-ZR-HD, with heavy-duty guide

Peripherals overview

Variants and accessories		
Type	Brief description	→ Page/Internet
1 Toothed belt axis DGE-ZR-HD	Electromechanical axis with heavy-duty guide	60
2 Slot nut for slide X	For mounting loads and attachments on the slide	86
3 Central mounting Q	For centring loads and attachments on the slide	86
4 Shock absorber kits D	For avoiding damage at the end stop in the event of malfunction	83
5 Axial kit EAMM-A	For axial motor attachment (consisting of: coupling housing, clamping component, motor flange)	72
6 Motor EMMS	Motors specially matched to the axis, with or without gearing, with or without brake	72
7 Slot nut for profile slot Y	For mounting attachments	86
8 Slot cover B/S	For protecting against dirt	86
9 Proximity sensor G/H/I/J/N	For use as a signal or safety check	87
10 Cable with socket V	For proximity sensors	87
11 Slot nut for HD underneath U	For mounting attachments	86
12 Central support M	For mounting the axis	80
13 Foot mounting F	For mounting the axis	80

Toothed belt axes DGE-ZR-HD, with heavy-duty guide

Type code

	DGE	-	25	-	500	-	ZR	-	LK	-	RV	-		-	GK
Type															
DGE	Toothed belt drive														
Size															
Stroke [mm]															
Drive function															
ZR	Toothed belt														
Drive shaft on left															
LK	No drive shaft on left														
LV	Drive shaft on left, front														
LH	Drive shaft on left, rear														
LB	Drive shaft on left, front and rear														
Drive shaft on right															
RK	No drive shaft on right														
RV	Drive shaft on right, front														
RH	Drive shaft on right, rear														
RB	Drive shaft on right, front and rear														
Guide															
HD	Heavy-duty guide														
Slide															
GK	Standard slide														

Toothed belt axes DGE-ZR-HD, with heavy-duty guide

Type code

→		+ ZUB	-	2S	-		-		-	F			Q		2H		2V
Accessories																	
ZUB	Accessories supplied loose																
Slot cover																	
...S	Sensor slot																
...B	Mounting slot																
Slot nut																	
...Y	For profile slot																
...X	For slide																
...U	For HD underneath																
Central support																	
...M	Central support																
Foot mounting																	
...F	Foot mounting																
Shock absorber																	
...D	Kit for HD																
Central mounting																	
...Q	Central mounting																
Proximity sensor																	
...G	With cable, 2.5 m																
...H	With plug																
...I	Contactless, with cable, 2.5 m																
...J	Contactless, plug																
...N	NC contact with cable, 2.5 m																
Cable with socket																	
...V	2.5 m																

Toothed belt axes DGE-ZR-HD, with heavy-duty guide

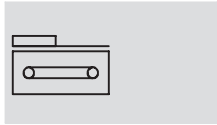

Technical data

Function

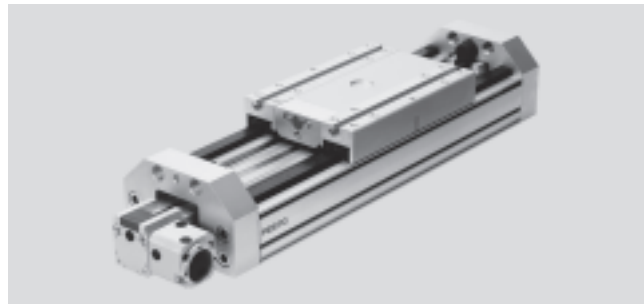

 www.festo.com



-  Size
18 ... 40
-  Stroke length
1 ... 2000 mm

General technical data					
Size		18-HD18	25-HD25	25-HD40	40-HD40
Constructional design		Electromechanical axis with heavy-duty guide			
Guide		Recirculating ball bearing guide			
Mounting position		Any			
Max. working stroke	[mm]	1 ... 1000	1 ... 2000	1 ... 2000	1 ... 2000
Max. working load	[kg]	4.2	18	16	48
Max. feed force F_x	[N]	60	260	260	610
Max. radial force ¹⁾	[N]	290	307	307	984
Radial force ²⁾	[N]	117	235	235	370
Radial force ³⁾	[N]	80	140	140	170
Max. driving torque	[Nm]	0.5	2.6	2.6	9.7
Max. no-load driving torque ⁴⁾	[Nm]	0.2	0.5	0.5	1
Max. speed	[m/s]	3			
Repetition accuracy	[mm]	±0.08		±0.1	

- 1) On the drive shaft
- 2) On the drive shaft, with a service life of 5,000 km
- 3) On the drive shaft, with a service life of 10,000 km
- 4) Measured at a speed of 0.2 m/s

Operating and environmental conditions					
Size		18-HD18	25-HD25	25-HD40	40-HD40
Ambient temperature	[°C]	-10 ... +40			
Protection class		IP40			

Weights [kg]					
Size		18-HD18	25-HD25	25-HD40	40-HD40
Basic weight with 0 mm stroke ¹⁾		3.812	5.63	14.33	17.75
Additional weight per 100 mm stroke		0.883	1.51	2.1	2.42

- 1) Including coupling housing and slide

Mass moment of inertia					
Size		18-HD18	25-HD25	25-HD40	40-HD40
J_0	[kg cm ²]	0.372	2.32	4.23	12
J_H per metre stroke	[kg cm ² /m]	0.021	0.078	0.078	0.45
J_L per kg working load	[kg cm ² /kg]	0.685	1	1	2.53

The mass moment of inertia J_A of the entire axis is calculated as follows:

$$J_A = J_0 + J_H \times \text{working stroke [m]} + J_L \times m_{\text{working load [kg]}}$$

Toothed belt axes DGE-ZR-HD, with heavy-duty guide

Technical data

Toothed belt		18-HD18	25-HD25	25-HD40	40-HD40
Size					
Tensile stress ¹⁾	[%]	0.2	0.11	0.11	0.1
Pitch	[mm]	2	3	3	5
Effective radius; effective diameter	[mm]	16.55	20.05	20.05	31.83
Feed constant	[mm]	52	63	63	100

1) At max. feed force

Materials

Sectional view

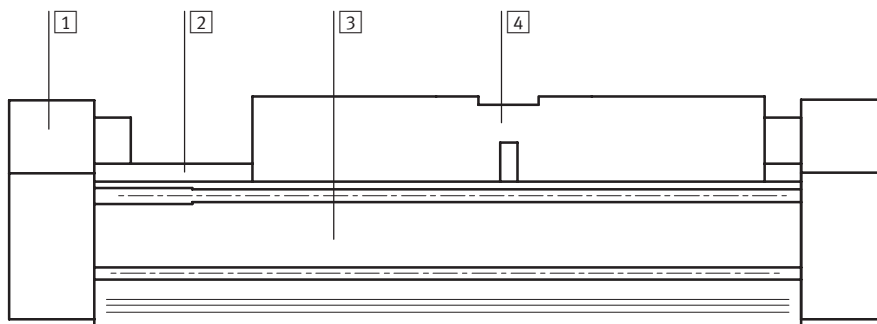

Axis		
1	End cap	Anodised aluminium
2	Guide	Rolled steel
3	Profile	Anodised aluminium
4	Slide	Anodised aluminium

Toothed belt axes DGE-ZR-HD, with heavy-duty guide

Technical data

Characteristic load values

The indicated forces and torques refer to the centre of the heavy-duty guide.

They must not be exceeded in the dynamic range. Special attention must be paid to the cushioning phase.

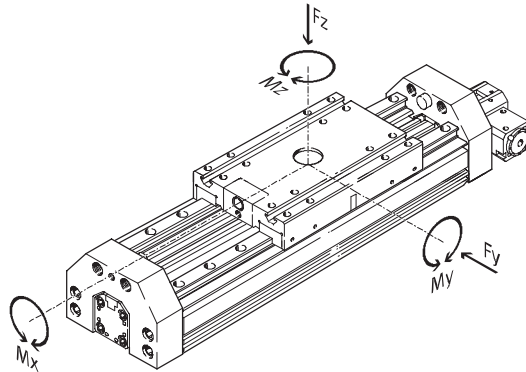

If the drive is subjected to more than two of the indicated forces and torques simultaneously, the following equations must be satisfied in addition to the indicated maximum loads.

$$\frac{F_y}{F_{y_{max}}} + \frac{F_z}{F_{z_{max}}} + \frac{M_x}{M_{x_{max}}} + \frac{M_y}{M_{y_{max}}} + \frac{M_z}{M_{z_{max}}} \leq 1$$

Permissible forces and torques		18-HD18	25-HD25	25-HD40	40-HD40
Size		18-HD18	25-HD25	25-HD40	40-HD40
F _y _{max.}	[N]	1820	5400	5400	5400
F _z _{max.}	[N]	1820	5600	5600	5600
M _x _{max.}	[Nm]	70	260	375	375
M _y _{max.}	[Nm]	115	415	560	560
M _z _{max.}	[Nm]	112	400	540	540

-  - Note

Sizing software
PositioningDrives
→ www.festo.com

Toothed belt axes DGE-ZR-HD, with heavy-duty guide

Technical data

Maximum permissible support span l as a function of the force F

The axis may need to be supported with central supports MUP in order to restrict deflection with long stroke lengths. The following diagrams serve to determine the maximum permissible support span l as a function of the force acting upon the axis F .

Force on the surface of the slide

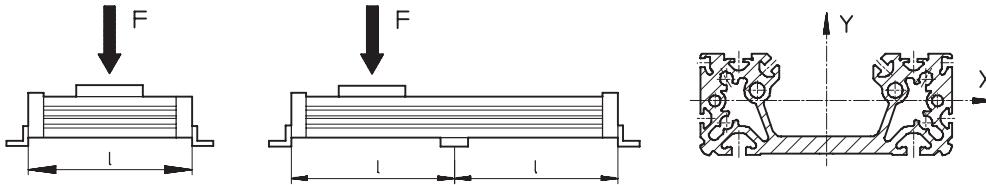

Maximum permissible support span l (without central support) as a function of the force F

Deflection around the X axis

Deflection around the Y axis

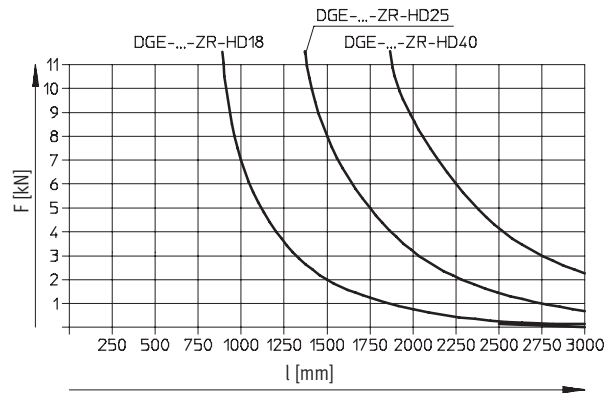
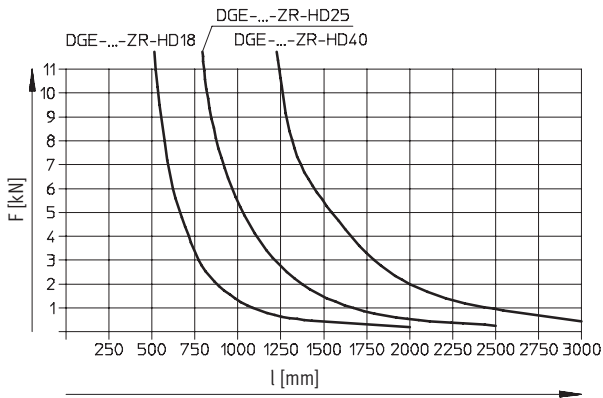

Toothed belt axes DGE-ZR-HD, with heavy-duty guide

Technical data

Maximum permissible acceleration a as a function of the effective load m

DGE-18-...-ZR-HD18

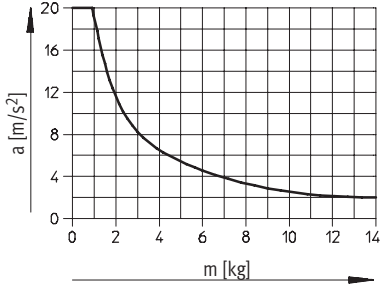

DGE-25-...-ZR-HD25

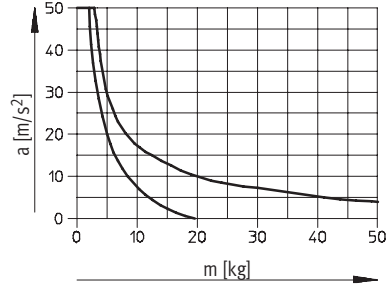

DGE-25-...-ZR-HD40

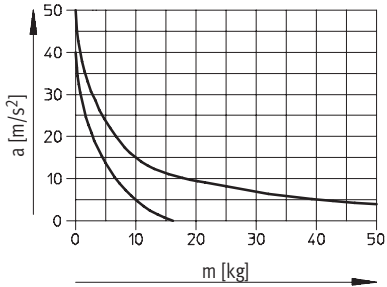

DGE-40-...-ZR-HD40

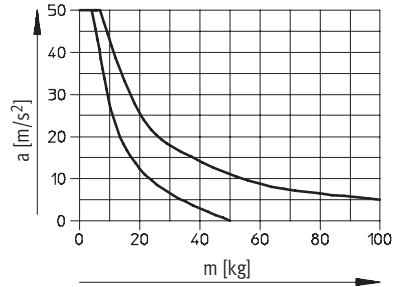

- - - vertical
 — horizontal

Toothed belt axes DGE-ZR-HD, with heavy-duty guide

Technical data

Dimensions

Download CAD data → www.festo.com

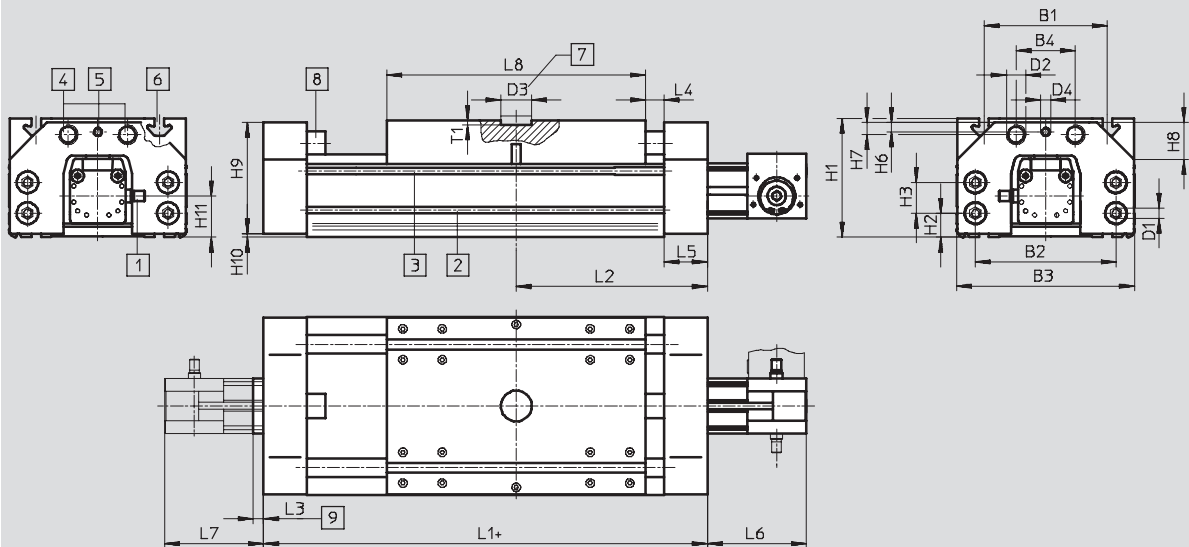

- 1 Drive spigot
 - 2 Mounting slot for slot nut NST
 - 3 Sensor slot for proximity sensor
 - 4 Thread for shock absorber
 - 5 Thread for threaded pin
 - 6 Mounting slot for slot nut NSTH
 - 7 Hole for central mounting SLZZ
 - 8 Rubber buffer
 - 9 Dimension for motor connection on one side
- + = plus stroke length

Profile

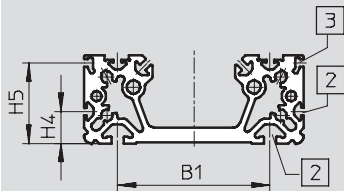

- 2 Mounting slot for slot nut NST
- 3 Sensor slot for proximity sensor

Size	B1	B2	B3 ±0,2	B4	D1	D2	D3 ∅ G7	D4	H1	H2	H3	H4	H5	H6
18-HD-18	80	85	116	40	M5	M12x1	25	M6	70	12.8	19.5±0,1	14	42.3	5.9
25-HD-25	100	114	144	48	M8	M16x1	25	M8	93.5	18.5	25±0,2	21	52.8	9
25-HD-40	140	156	185	54	M8	M22x1.5	25	M8	124.5	21	48±0,2	35	82.8	5.5
40-HD-40	140	156	185	54	M8	M22x1.5	25	M8	124.5	21	48±0,2	35	82.8	5.5

Size	H7	H8	H9	H10	H11	L1	L2	L3	L4	L5	L6	L7	L8	T1
18-HD-18	8.7	20x45°	68	0.8	24.9	240	120	-	15	25	70	59	160	3.5
25-HD-25	9.8	30x45°	90	2	28.9	310	155	-	15	35	80	61	210	3.5
25-HD-40	15.5	35x45°	120	2	54.9	354	177	-	15	32	82	63	260	4
40-HD-40	15.5	35x45°	120	2	42.5	354	177	15	15	32	109	82	260	4

Toothed belt axes DGE-ZR-HD, with heavy-duty guide

Ordering data – Modular products

Order code

Mandatory data

- LK No drive shaft on left
- LV Drive shaft on left, front
- LH Drive shaft on left, rear
- LB Drive shaft on left, front and rear
- RK No drive shaft on right
- RV Drive shaft on right, front
- RH Drive shaft on right, rear
- RB Drive shaft on right, front and rear

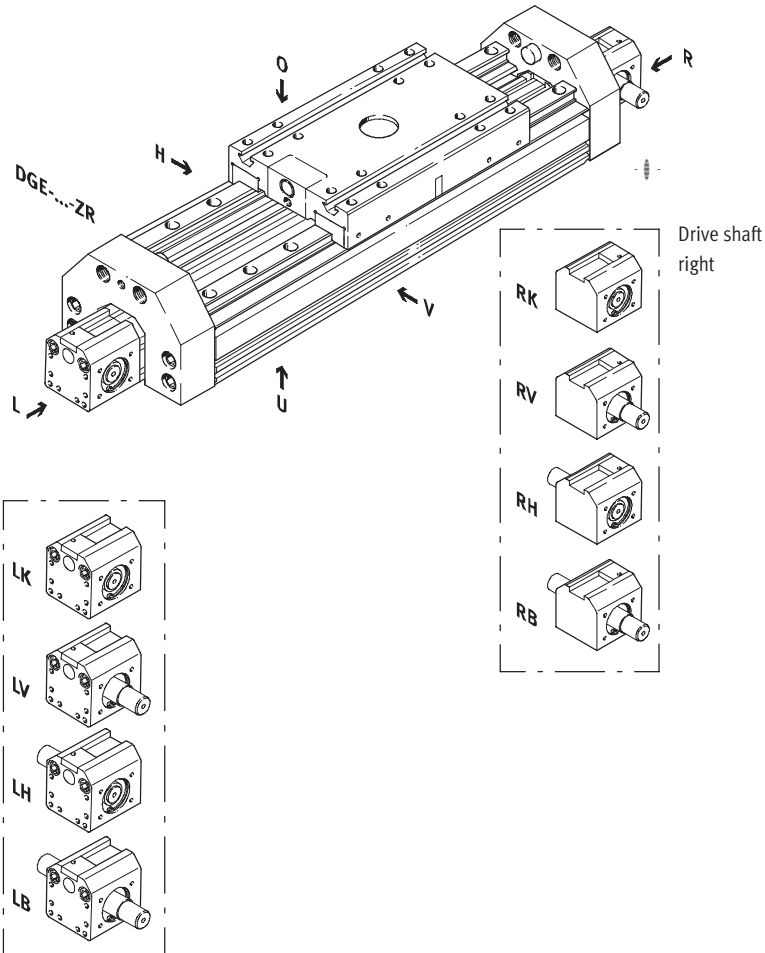

-  - Note

The insertion point for the proximity sensor is located on the right side of the heavy-duty guide.

O top
 U underneath
 R right
 L left
 V front
 H rear

Toothed belt axes DGE-ZR-HD, with heavy-duty guide

Ordering data – Modular products

Order code

Options

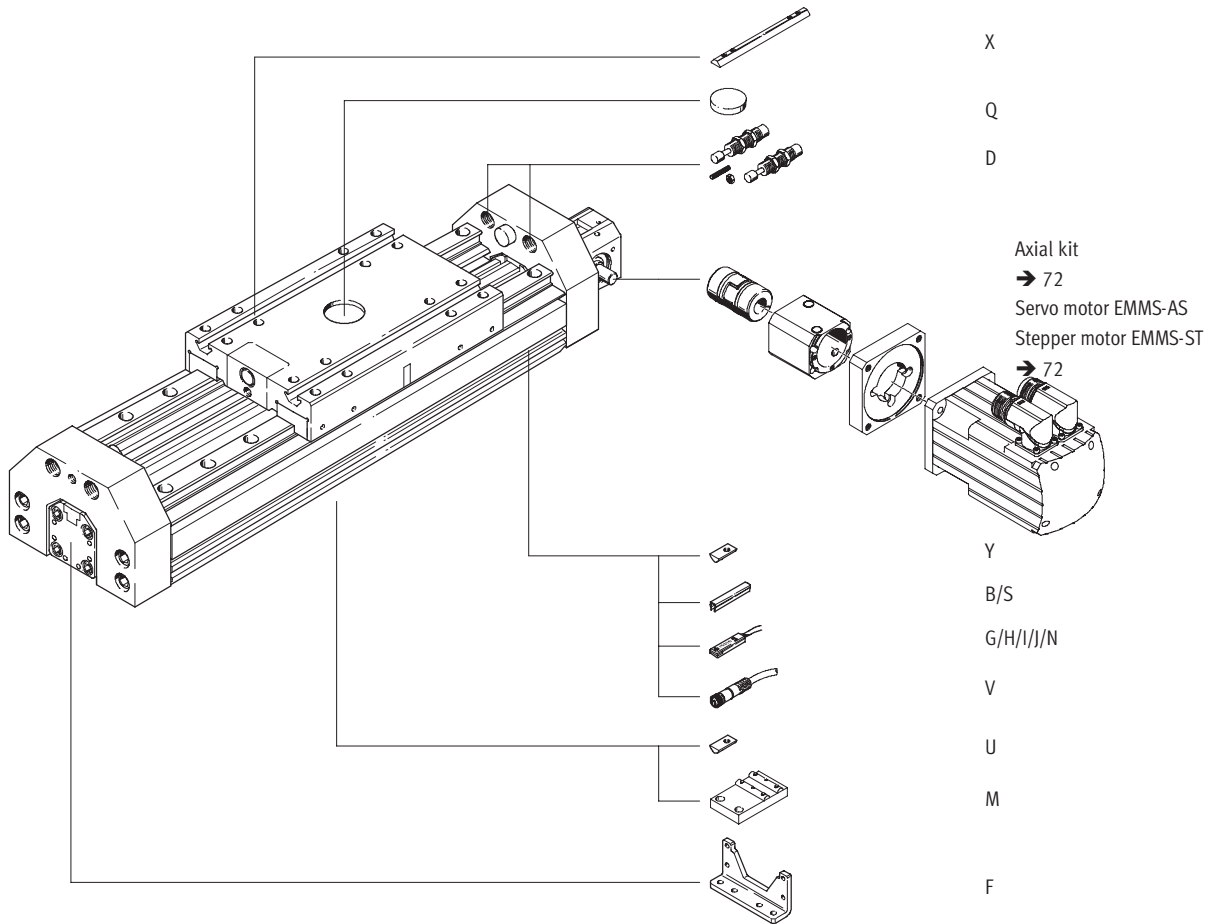

Toothed belt axes DGE-ZR-HD, with heavy-duty guide

Ordering data – Modular products

M Mandatory data							O Options →	
Module No.	Design	Size	Stroke	Drive function	Drive shaft on left	Drive shaft on right	Guide	Slide
193 741 193 742 193 743	DGE	18 25 40	1 ... 2000	ZR	LK LV LH LB	RK RV RH RB	HD18 HD25 HD40	GK
Ordering example								
193 742	DGE	- 25	- 800	- ZR	- LK	- RV	- HD40	- GK

Ordering table							
Size	18	25	40	Condi- tions	Code	Enter code	
M Module No.	193 741	193 742	193 743				
Design	Electromechanical linear axis				DGE	DGE	
Size	18	25	40		-...		
Stroke [mm]	1 ... 1000	1 ... 2000	1 ... 2000		-...		
Drive function	Electromechanical drive with toothed belt				-ZR	-ZR	
Drive shaft on left	No drive shaft on left			1	-LK		
	Drive shaft on left, front				-LV		
	Drive shaft on left, rear				-LH		
	Drive shaft on left, front and rear				-LB		
Drive shaft on right	No drive shaft on right			2	-RK		
	Drive shaft on right, front				-RV		
	Drive shaft on right, rear				-RH		
	Drive shaft on right, front and rear				-RB		
O Guide	Heavy-duty guide HD18	-	-		-HD18	-HD...	
	-	Heavy-duty guide HD25	-		-HD25		
	-	Heavy-duty guide HD40	Heavy-duty guide HD40		-HD40		
Slide	Standard				-GK	-GK	

1 LK Not with drive shaft on right RK.

2 RK Not with drive shaft on left LK.

* Transfer order code

	DGE	-		-	ZR	-		-	HD...	-	GK
--	-----	---	--	---	----	---	--	---	-------	---	----

Toothed belt axes DGE-ZR-HD, with heavy-duty guide

Ordering data – Modular products

Options								
Accessories	Slot cover	Slot nut	Central support	Foot mounting	Shock absorber	Central mounting	Proximity sensor	Plug socket
ZUB	...S ...B	...Y ...X ...U	...M	...F	...D	...Q	...G ...H ...I ...J ...N	...V
ZUB	- 2S2B	10U		F		2Q	2H	2V

Ordering table						
Size	18	25	40	Condi- tions	Code	Enter code
Accessories	Supplied separately				ZUB-	ZUB-
Slot cover	Sensor slot	1 ... 10			...S	
	Mounting slot	1 ... 10			...B	
Slot nut	for mounting slot	1 ... 10			...Y	
	for slide	1 ... 10			...X	
	for HD underneath	1 ... 10			...U	
Central support	1 ... 10			...M		
Foot mounting (kit)	1 ... 10			...F		
Shock absorber Kit for HD	1 ... 2			...D		
Central mounting	1 ... 10			...Q		
Proximity sensor	with cable 2.5 m	1 ... 10			...G	
	with plug	1 ... 10			...H	
	contactless with cable 2.5 m	1 ... 10			...I	
	contactless, plug	1 ... 10			...J	
	NC contact with cable 2.5 m	1 ... 10			...N	
Cable with socket 2.5 m	1 ... 10			...V		



Transfer order code

ZUB -

Toothed belt axes DGE

Accessories

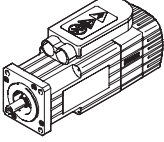
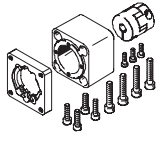

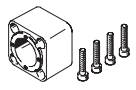
FESTO

Permissible axis/motor combinations with axial kit – Without gear unit				
Motor	Axial kit	Axial kit consisting of:		
		Motor flange	Coupling	Coupling housing
				
Type	Part No. Type	Part No. Type	Part No. Type	Part No. Type
DGE-8-...-ZR				
With servo motor				
EMMS-AS-40-...	550 921 EAMM-A-G13-40A	540 301 EAMF-A-28A/30A-40A	540 750 EAMC-15-22-4-6	171 186 EAMK-A-G13-28A
With stepper motor				
EMMS-ST-42-...	550 922 EAMM-A-G13-42A	530 080 EAMF-A-28A-42A	530 084 EAMC-15-22-4-5	171 186 EAMK-A-G13-28A
DGE-12-...-ZR				
With servo motor				
EMMS-AS-40-...	550 923 EAMM-A-G16-40A	540 301 EAMF-A-28A/30A-40A	540 750 EAMC-15-22-4-6	171 185 EAMK-A-G16-30A
EMMS-AS-55-...	550 925 EAMM-A-G16-55A	534 807 EAMF-A-30A-55A	184 262 EAMC-15-22-4-9	171 185 EAMK-A-G16-30A
With stepper motor				
EMMS-ST-42-...	550 924 EAMM-A-G16-42A	530 079 EAMF-A-30A-42A	530 084 EAMC-15-22-4-5	171 185 EAMK-A-G16-30A
DGE-18-...-ZR				
With servo motor				
EMMS-AS-40-...	550 926 EAMM-A-G19-40A	550 985 EAMF-A-44A/B-40A	184 265 EAMC-19-24-6-6	170 375 EAMK-A-G19-44B
EMMS-AS-55-...	550 927 EAMM-A-G19-55A	529 942 EAMF-A-44A/B-55A	184 263 EAMC-19-24-6-9	170 375 EAMK-A-G19-44B
With stepper motor				
EMMS-ST-57-...	550 928 EAMM-A-G19-57A	530 081 EAMF-A-44A/B-57A	530 086 EAMC-19-24-6-6.35	170 375 EAMK-A-G19-44B
DGE-25-...-ZR				
With servo motor				
EMMS-AS-55-...	550 929 EAMM-A-F30-55A	529 942 EAMF-A-44A/B-55A	557 390 EAMC-30-35-8-9	124 628 EAMK-A-F30-44A
EMMS-AS-70-...	550 932 EAMM-A-F30-70A	529 943 EAMF-A-44A/B-70A	123 042 EAMC-30-35-8-11	124 628 EAMK-A-F30-44A
With stepper motor				
EMMS-ST-57-...	550 930 EAMM-A-F30-57A	530 081 EAMF-A-44A/B-57A	530 088 EAMC-30-35-6.35-8	124 628 EAMK-A-F30-44A
EMMS-ST-87-...	550 933 EAMM-A-F30-87A	530 082 EAMF-A-44A/B-87A	123 042 EAMC-30-35-8-11	124 628 EAMK-A-F30-44A

Toothed belt axes DGE

Accessories

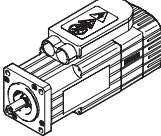
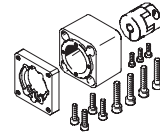
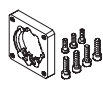

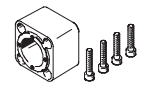
FESTO

Permissible axis/motor combinations with axial kit – Without gear unit				
Motor	Axial kit	Axial kit consisting of:		
		Motor flange	Coupling	Coupling housing
				
Type	Part No. Type	Part No. Type	Part No. Type	Part No. Type
DGE-25-...-ZR-RF				
With servo motor				
EMMS-AS-55-...	550 942 EAMM-A-F37-55A	529 942 EAMF-A-44A/B-55A	557 390 EAMC-30-35-8-9	534 394 EAMK-A-F37-44A
EMMS-AS-70-...	550 945 EAMM-A-F37-70A	529 943 EAMF-A-44A/B-70A	123 042 EAMC-30-35-8-11	534 394 EAMK-A-F37-44A
With stepper motor				
EMMS-ST-57-...	550 943 EAMM-A-F37-57A	530 081 EAMF-A-44A/B-57A	530 088 EAMC-30-35-6.35-8	534 394 EAMK-A-F37-44A
EMMS-ST-87-...	550 946 EAMM-A-F37-87A	530 082 EAMF-A-44A/B-87A	123 042 EAMC-30-35-8-11	534 394 EAMK-A-F37-44A
DGE-40-...-ZR				
With servo motor				
EMMS-AS-70-...	550 934 EAMM-A-F40-70A	529 945 EAMF-A-64A/B-70A	550 998 EAMC-40-66-11-15	124 629 EAMK-A-F40-64A
EMMS-AS-100-...	550 937 EAMM-A-F40-100A	529 947 EAMF-A-64A/C-100A	123 844 EAMC-40-66-15-19	124 629 EAMK-A-F40-64A
With stepper motor				
EMMS-ST-87-...	550 936 EAMM-A-F40-87A	533 140 EAMF-A-64A/B-87A	550 998 EAMC-40-66-11-15	124 629 EAMK-A-F40-64A
DGE-40-...-ZR-RF				
With servo motor				
EMMS-AS-100-...	550 949 EAMM-A-F47-100A	529 947 EAMF-A-64A/C-100A	123 844 EAMC-40-66-15-19	534 395 EAMK-A-F47-64A
EMMS-AS-140-...	550 950 EAMM-A-F47-140A	550 988 EAMF-A-64A-140A	176 033 EAMC-40-66-15-24	534 395 EAMK-A-F47-64A
With stepper motor				
EMMS-ST-87-...	550 948 EAMM-A-F47-87A	533 140 EAMF-A-64A/B-87A	550 998 EAMC-40-66-11-15	534 395 EAMK-A-F47-64A
DGE-63-...-ZR				
With servo motor				
EMMS-AS-100-...	550 939 EAMM-A-F62-100A	529 949 EAMF-A-118C-100A	551 000 EAMC-65-90-19-25	124 630 EAMK-A-F62-118A/B/C
EMMS-AS-140-...	550 941 EAMM-A-F62-140A	550 991 EAMF-A-118B-140A	123 852 EAMC-65-90-24-25	124 630 EAMK-A-F62-118A/B/C
DGE-63-...-ZR-RF				
With servo motor				
EMMS-AS-100-...	550 952 EAMM-A-F80-100A	529 949 EAMF-A-118C-100A	551 000 EAMC-65-90-19-25	534 396 EAMK-A-F80-118A/B/C
EMMS-AS-140-...	550 954 EAMM-A-F80-140A	550 991 EAMF-A-118B-140A	123 852 EAMC-65-90-24-25	534 396 EAMK-A-F80-118A/B/C

Toothed belt axes DGE

Accessories

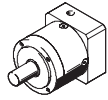
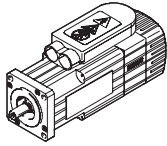
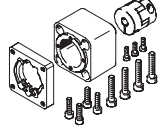

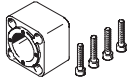
FESTO

Permissible axis/motor combinations with axial kit – With gear unit					
Gear unit	Motor	Axial kit	Axial kit consisting of:		
			Motor flange	Coupling	Coupling housing
					
Type	Type	Part No. Type	Part No. Type	Part No. Type	Part No. Type
DGE-25-...-ZR					
With servo motor					
EMGA-60-P-G...-SAS-55	EMMS-AS-55-...	550 931 EAMM-A-F30-60G	529 944 EAMF-A-44A/B-60G	123 042 EAMC-30-35-8-11	124 628 EAMK-A-F30-44A
With stepper motor					
EMGA-60-P-G...-SST-57	EMMS-ST-57-...	550 931 EAMM-A-F30-60G	529 944 EAMF-A-44A/B-60G	123 042 EAMC-30-35-8-11	124 628 EAMK-A-F30-44A
DGE-25-...-ZR-RF					
With servo motor					
EMGA-60-P-G...-SAS-55	EMMS-AS-55-...	550 944 EAMM-A-F37-60G	529 944 EAMF-A-44A/B-60G	123 042 EAMC-30-35-8-11	534 394 EAMK-A-F37-44A
With stepper motor					
EMGA-60-P-G...-SST-57	EMMS-ST-57-...	550 944 EAMM-A-F37-60G	529 944 EAMF-A-44A/B-60G	123 042 EAMC-30-35-8-11	534 394 EAMK-A-F37-44A
DGE-40-...-ZR					
With servo motor					
EMGA-80-P-G...-SAS-100	EMMS-AS-100-...	550 935 EAMM-A-F40-80G	533 139 EAMF-A-64A/C-80G	123 845 EAMC-40-66-15-20	124 629 EAMK-A-F40-64A
With stepper motor					
EMGA-80-P-G...-SST-87	EMMS-ST-87-...	550 935 EAMM-A-F40-80G	533 139 EAMF-A-64A/C-80G	123 845 EAMC-40-66-15-20	124 629 EAMK-A-F40-64A
DGE-40-...-ZR-RF					
With servo motor					
EMGA-80-P-G...-SAS-100	EMMS-AS-100-...	550 947 EAMM-A-F47-80G	533 139 EAMF-A-64A/C-80G	123 845 EAMC-40-66-15-20	534 395 EAMK-A-F47-64A
With stepper motor					
EMGA-80-P-G...-SST-87	EMMS-ST-87-...	550 947 EAMM-A-F47-80G	533 139 EAMF-A-64A/C-80G	123 845 EAMC-40-66-15-20	534 395 EAMK-A-F47-64A

Toothed belt axes DGE

Accessories

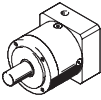
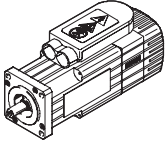
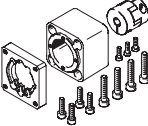
FESTO

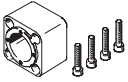
Permissible axis/motor combinations with axial kit – With gear unit					
Gear unit	Motor	Axial kit	Axial kit consisting of:		
			Motor flange	Coupling	Coupling housing
					
Type	Type	Part No. Type	Part No. Type	Part No. Type	Part No. Type
DGE-63-...-ZR					
With servo motor					
EMGA-120-P-G...-SAS-100	EMMS-AS-100-...	550 940 EAMM-A-F62-120G	550 990 EAMF-A-118A-120G	123 853 EAMC-65-90-25-25	124 630 EAMK-A-F62-118A/B/C
EMGA-120-P-G...-SAS-140	EMMS-AS-140-...	550 940 EAMM-A-F62-120G	550 990 EAMF-A-118A-120G	123 853 EAMC-65-90-25-25	124 630 EAMK-A-F62-118A/B/C
With stepper motor					
EMGA-80-P-G...-SST-87	EMMS-ST-87-...	550 938 EAMM-A-F62-80G	550 989 EAMF-A-118A-80G	176 035 EAMC-65-90-20-25	124 630 EAMK-A-F62-118A/B/C
DGE-63-...-ZR-RF					
With servo motor					
EMGA-80-P-G...-SAS-100	EMMS-AS-100-...	550 951 EAMM-A-F80-80G	550 989 EAMF-A-118A-80G	176 035 EAMC-65-90-20-25	534 396 EAMK-A-F80-118A/B/C
EMGA-120-P-G...-SAS-140	EMMS-AS-140-S...	550 953 EAMM-A-F80-120G	550 990 EAMF-A-118A-120G	123 853 EAMC-65-90-25-25	534 396 EAMK-A-F80-118A/B/C
EMGA-160-P-G...-SAS-140	EMMS-AS-140-M...	550 955 EAMM-A-F80-160G	550 992 EAMF-A-118A-160G	551 001 EAMC-65-90-25-40	534 396 EAMK-A-F80-118A/B/C
With stepper motor					
EMGA-80-P-G...-SST-87	EMMS-ST-87-...	550 951 EAMM-A-F80-80G	550 989 EAMF-A-118A-80G	176 035 EAMC-65-90-20-25	534 396 EAMK-A-F80-118A/B/C

Toothed belt axes DGE

Accessories

FESTO

Axialkit EAMM-A-...

Material:
Coupling housing, coupling hubs:
Aluminium
Clamping component:
Steel, corrosion resistant
Motor flange:
Wrought aluminium alloy
Screws: Galvanised steel

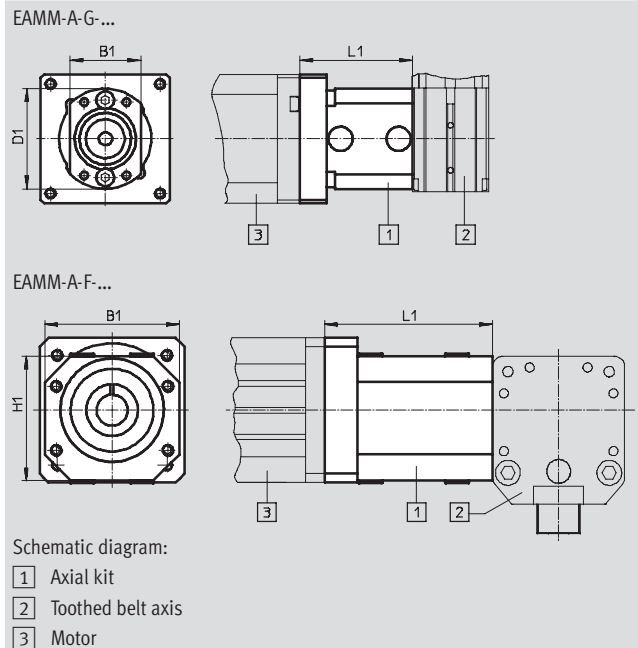

General technical data														
EAMM-A-...		G13-		G16-			G19-			F30-				
		40A	42A	40A	55A	42A	40A	55A	57A	55A	57A	70A	87A	60G
Transferable torque	[Nm]	1		1			1.5			8	7.5	8		
Mass moment of inertia	[kgmm ²]	0.13		0.13			0.47			6.1				
Max. speed	[1/min]	12000		12000			8000			8000				
Mounting position		Any												

EAMM-A-...		F37-					F40-				F47-			
		55A	57A	70A	87A	60G	70A	87A	100A	80G	87A	100A	140A	80G
Transferable torque	[Nm]	8	7.5	8		17				17				
Mass moment of inertia	[kgmm ²]	6.1					42.3				42.3			
Max. speed	[1/min]	8000					6500				6500			
Mounting position		Any												

EAMM-A-...		F62-				F80-					
		100A	140A	80G	120G	100A	140A	80G	120G	160G	
Transferable torque	[Nm]	85	92	85	92	85	92	85	92	62	
Mass moment of inertia	[kgmm ²]	417				417					
Max. speed	[1/min]	4500				4500					
Mounting position		Any									

Operating and environmental conditions		
Ambient temperature	[°C]	0 ... 50
Storage temperature	[°C]	-25 ... +60
Protection class ¹⁾		IP40
Relative air humidity	[%]	0 ... 95

1) Only with combined attachment of motor and axis

Toothed belt axes DGE

Accessories

FESTO

Dimensions and ordering data						
Type	B1	H1	L1	Weight [g]	Part No.	Type
EAMM-A-G13-40A	22	29	33.9	71	550 921	EAMM-A-G13-40A
EAMM-A-G13-42A			42.2	84	550 922	EAMM-A-G13-42A
EAMM-A-G16-40A		31	34.9	76	550 923	EAMM-A-G16-40A
EAMM-A-G16-42A			42.4	117	550 924	EAMM-A-G16-42A
EAMM-A-G16-55A	31	44.5	37.7	138	550 925	EAMM-A-G16-55A
EAMM-A-G19-40A			38.5	158	550 926	EAMM-A-G19-40A
EAMM-A-G19-55A			39.7	183	550 927	EAMM-A-G19-55A
EAMM-A-G19-57A			41	199	550 928	EAMM-A-G19-57A
EAMM-A-F30-55A	45	45	51.4	271	550 929	EAMM-A-F30-55A
EAMM-A-F30-57A			52.7	282	550 930	EAMM-A-F30-57A
EAMM-A-F30-70A			54.2	327	550 932	EAMM-A-F30-70A
EAMM-A-F30-87A			56.2	439	550 933	EAMM-A-F30-87A
EAMM-A-F30-60G			60.7	409	550 931	EAMM-A-F30-60G
EAMM-A-F37-55A	45	45	51.4	271	550 942	EAMM-A-F37-55A
EAMM-A-F37-57A			52.7	274	550 943	EAMM-A-F37-57A
EAMM-A-F37-70A			54.2	328	550 945	EAMM-A-F37-70A
EAMM-A-F37-87A			56.2	478	550 946	EAMM-A-F37-87A
EAMM-A-F37-60G			60.7	348	550 944	EAMM-A-F37-60G
EAMM-A-F40-70A	65	60	81.2	637	550 934	EAMM-A-F40-70A
EAMM-A-F40-87A			82.7	786	550 936	EAMM-A-F40-87A
EAMM-A-F40-100A			86.2	938	550 937	EAMM-A-F40-100A
EAMM-A-F40-80G			89.4	893	550 935	EAMM-A-F40-80G
EAMM-A-F47-87A	65	60	82.7	778	550 948	EAMM-A-F47-87A
EAMM-A-F47-100A			86.2	1012	550 949	EAMM-A-F47-100A
EAMM-A-F47-140A			95.5	1927	550 950	EAMM-A-F47-140A
EAMM-A-F47-80G			89.4	1000	550 947	EAMM-A-F47-80G
EAMM-A-F62-100A	100	100	116.2	2538	550 939	EAMM-A-F62-100A
EAMM-A-F62-140A			112	2777	550 941	EAMM-A-F62-140A
EAMM-A-F62-80G			119	2760	550 938	EAMM-A-F62-80G
EAMM-A-F62-120G			119	2478	550 940	EAMM-A-F62-120G
EAMM-A-F80-100A	100	100	116.2	2563	550 952	EAMM-A-F80-100A
EAMM-A-F80-140A			112	2635	550 954	EAMM-A-F80-140A
EAMM-A-F80-80G			119	2803	550 951	EAMM-A-F80-80G
EAMM-A-F80-120G			119	2725	550 953	EAMM-A-F80-120G
EAMM-A-F80-160G			151	5237	550 955	EAMM-A-F80-160G

 Note

Permissible axis/motor combinations

➔ 73

Toothed belt axes DGE

Accessories

FESTO

Foot mounting HP
(order code F)

Material:
Galvanised steel
Free of copper, PTFE and silicone



HP-25

DGE-8-...-18

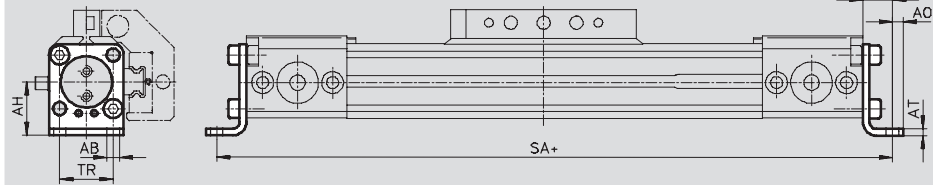

DGE-25-...-63

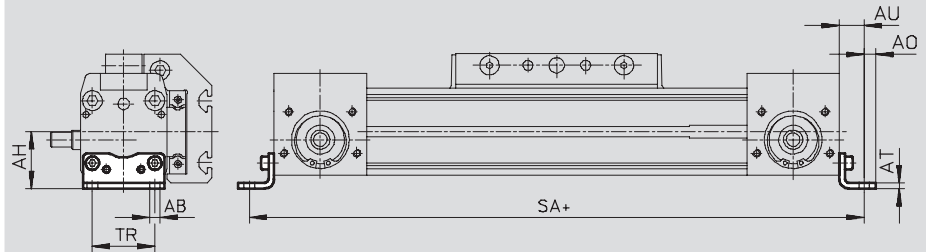

+ = plus stroke length

Dimensions and ordering data

For size	AB ∅	AH	A0	AT	AU	TR
8	3.4	13.8	3	2	9	13
12	3.4	16.5	3	2	9	18.6
18	5.5	24	4.8	3	13.3	24
25	5.5	29.5	6	3	13	32.5
40	6.6	46	8.5	5	17.5	45
63	11	69	13.5	6	28	75

For size	SA				Weight [g]	Part No.	Type
	For DGE-ZR/DGE-ZR-KF		For DGE-ZR-RF				
	GK	GV	GK	GV			
8	198	-	-	-	17	158 470	HP-8
12	234	-	-	-	23	158 471	HP-12
18	308.6	388.6	-	-	70	158 472	HP-18
25	398	498	440	535	61	150 731	HP-25
40	604	774	673	813	188	150 733	HP-40
63	938	1188	1076	1306	305	150 735	HP-63

Toothed belt axes DGE

Accessories

Central support MUP
(order code M)

Material:
Galvanised steel
Free of copper, PTFE and silicone



DGE-8-...-25

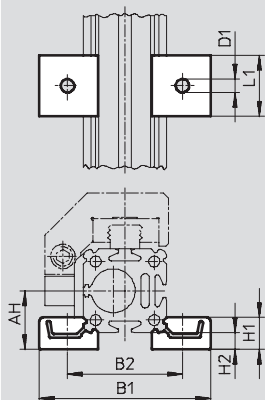

DGE-40-...-63

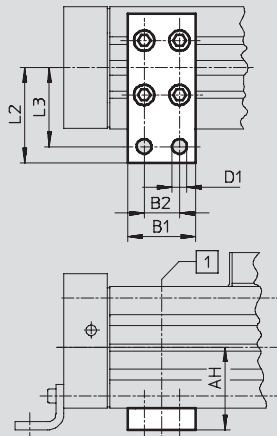

1 Position of the central support along the profile is freely selectable

Dimensions and ordering data

For size	AH	B1	B2	D1 Ø	H1	H2	L1	L2	L3	Weight [g]	Part No.	Type
8	13.8	40.5	28.5	3.5	8	4	15	-	-	8	160 909	MUP-8/12
12	16.5	46	34	3.5	8	4	15	-	-	8	160 909	MUP-8/12
18	24	70.5	47	5.5	13	7	25	-	-	33	150 736	MUP-18/25
25	29.5	81	58	5.5	13	7	25	-	-	33	150 736	MUP-18/25
40	46	35	22	6.6	-	-	-	47	40	126	150 738	MUP-40
63	69	50	26	11	-	-	-	77	65	340	150 800	MUP-63

Toothed belt axes DGE

Accessories



Foot mounting HHP

for heavy-duty guide

(order code F)

Material:

Galvanised steel



Central support MUP

for heavy-duty guide

(order code M)

Material:

Galvanised steel

Free of copper, PTFE and silicone

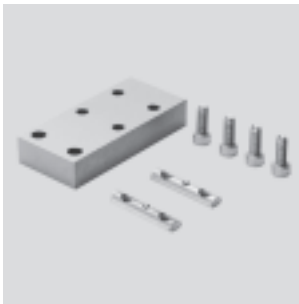

DGE-...-HD18/-HD25/-HD40

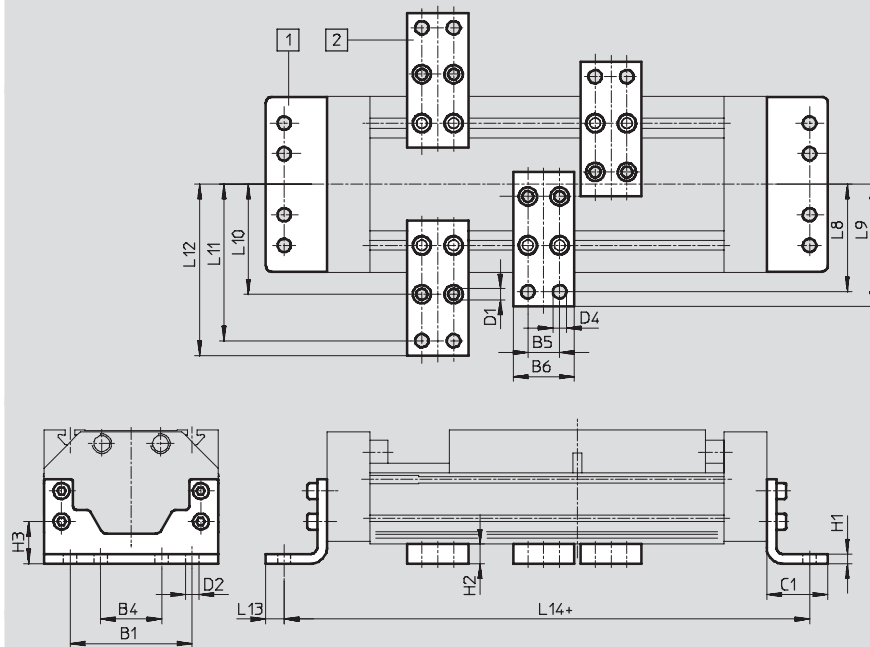

- 1 Foot mounting HHP
- 2 Central support MUP

+ = plus stroke length

Dimensions and ordering data											
For heavy-duty guide	B1	B4	B5	B6	C1	D1	D2	D4	H1	H2	H3
HD18	80	40	22	35	34	5.5	6.6	6.6	8	14	26.8
HD25	100	50	26	50	50	9	11	11	8	16	34.5
HD40	140	70	26	50	50	9	11	11	10	16	37

For heavy-duty guide	L8	L9	L10	L11	L12	L13	L14	Weight [g]	Part No.	Type
HD18	68	75	64	92	99	9	290	357	161 993	HHP-18
								126	150 738	MUP-40
HD25	88	100	90	128	140	15	380	794	161 994	HHP-25
								347	150 739	MUP-50
HD40	108	120	110	148	160	15	424	1318	161 995	HHP-40
								347	150 739	MUP-50

Toothed belt axes DGE

Accessories

Shock absorber YSR-...-C (order code C)

Material:
Housing: Galvanised steel
Piston rod: High-alloy steel
Seals: Perbunan, polyurethane
Free of copper, PTFE and silicone



 Note
Shock absorber YSRW with progressive characteristics
→ Internet: ysrw

Ordering data		Part No.	Type
For size	Weight [g]		
8	9	158 981	YSR-5-5-C
12	9	158 981	YSR-5-5-C
18	30	34 571	YSR-8-8-C
25	70	34 572	YSR-12-12-C
40	140	34 573	YSR-16-20-C
63	240	34 574	YSR-20-25-C

Shock absorber retainer KYP (order code C)

Material:
Retainer: Aluminium
Sleeve: Corrosion resistant steel



1 Shock absorber retainer KYP
(if the retainer is in contact with the front cap, i.e. cap serves to secure position, the entire stroke length can be utilised)

2 Shock absorber YSR-...-C

3 Position retainer
(included in scope of delivery) either behind or underneath the shock absorber retainer KYP

Dimensions and ordering data							
For size	B8	D1	D5	H2	H4	Weight [g]	Part No. Type
8	8	M8x1	M3	31.5	3	36	158 905 KYP-8
12	11	M8x1	M4	37	3	44	158 906 KYP-12
18	14	M12x1	M4	50.5	4.5	66	158 907 KYP-18
25	19	M16x1	M5	69.5	6	95	158 908 KYP-25
40	32	M22x1.5	M5	102	8	209	158 910 KYP-40
63	44	M26x1.5	M10	152.5	11.5	609	158 912 KYP-63

Toothed belt axes DGE

Accessories

FESTO

Emergency buffer NPE (order code A)

Material:
Polyurethane

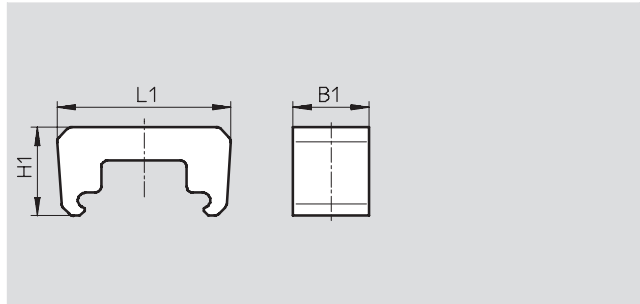
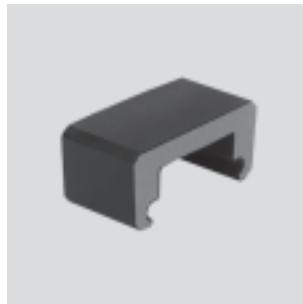

Dimensions and ordering data						
For size	B1	L1	H1	Weight [g]	Part No.	Type
18	15	43.1	28.5	6	193 901	NPE-18
25	25	57	29	12	193 902	NPE-25
40	40	80.5	36	41	193 904	NPE-40
63	60	128.6	55	152	193 906	NPE-63

 Note
The emergency buffer can only be used in conjunction with shock absorber retainer KYP → 81. (A threaded pin and nut are not required.)

Shock absorber DG-GA for protected version GA (order code E)

Material:
Housing: Galvanised steel
Piston rod: High-alloy steel
Seals: Perbunan, polyurethane
Free of copper, PTFE and silicone



Ordering data			
For size	Weight [g]	Part No.	Type
25	70	192 875	DG-GA-25-YSR
40	140	192 877	DG-GA-40-YSR

Toothed belt axes DGE

Accessories

Shock absorber kit YHD

for heavy-duty guide

(order code D)

Material:

Housing: Galvanised steel

Seals: TPE-U(PU) NBR

Free of copper, PTFE and silicone



Ordering data			
For heavy-duty guide	Weight [g]	Part No.	Type
HD18	203	174 544	YHD-18
HD25	293	174 545	YHD-25
HD40	515	174 546	YHD-40

Toothed belt axes DGE

Accessories



Sensor bracket HWS

for inductive proximity sensors

(order code T)

Material:

Galvanised steel



Switching lug SF

(order code L)

Material:

Galvanised steel



DGE-18-...-ZR-KF-...

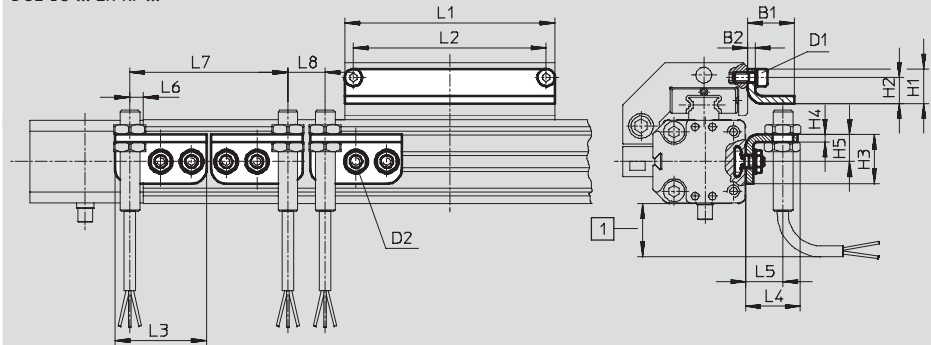

DGE-25-...-ZR-KF-...

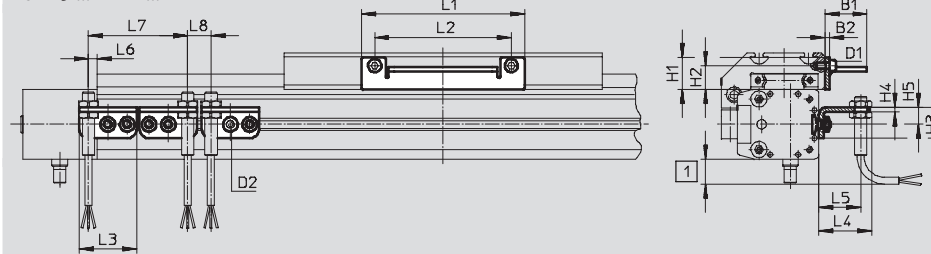

DGE-40/-63-...-ZR-KF-...

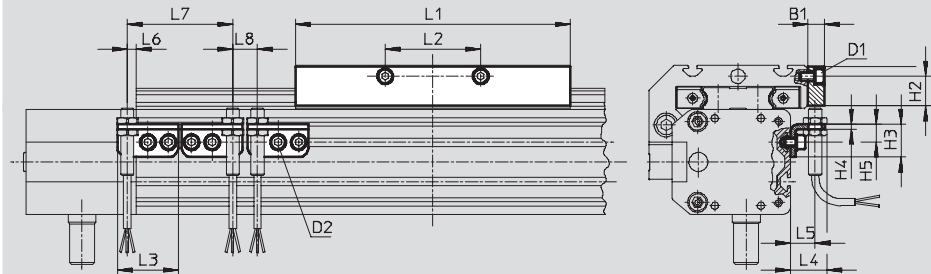

1 Protruding sensor cable, ensure sufficient installation space

Toothed belt axes DGE

Accessories

DGE-25-...-ZR-RF-...

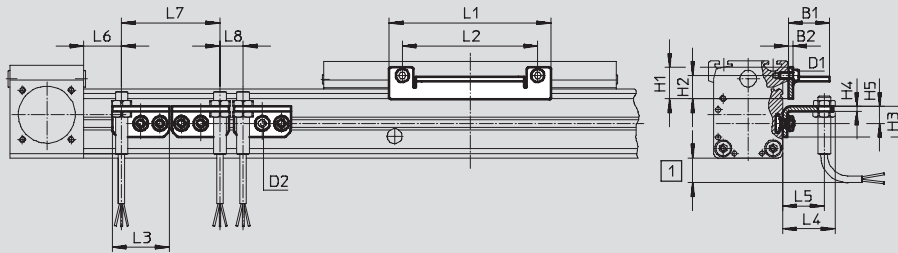

DGE-40/-63-...-ZR-RF-...

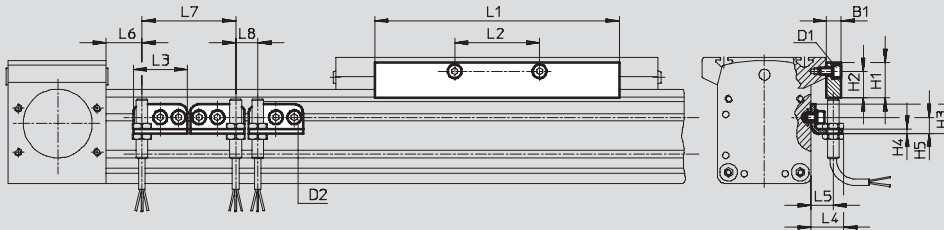

1 Protruding sensor cable, ensure sufficient installation space

Dimensions and ordering data



For size	D1	D2	B1	B2	H1	H2	H3	H4	H5	L1	L2	L3	L4	L5
18	M4	M5	19	3	14	10.5	20	3	11	85	78	37	22.5	15
25	M5	M5	27	3	20.5	15.3	20	3	11	105	88	37	34.5	27
40	M5	M5	10	-	24	18	20	3	11	167	58	37	22.5	15
63	M8	M5	10	-	35	25	20	3	11	230	72	37	22.5	15

For size	L6			L7 min.	L8 min.	Weight [g]	Part No.	Type
	DGE-ZR-KF max.	DGE-ZR-RF GK GV						
18	5.5	-	-	64	15	30	188 968	HWS-18/25-M8
							188 964	SF-18
25	5.5	43.5	91	64	15	30	540 780	HWS-25-MAB-M8
							540 430	SF-25-MAB
40	5.5	68.5	138.5	64	15	40	188 969	HWS-40-M8
							188 966	SF-40
63	5.5	117	232	64	15	40	188 970	HWS-63-M8
							188 967	SF-63

Toothed belt axes DGE

Accessories

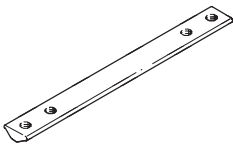
FESTO

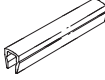
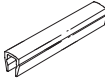

Ordering data				Technical data → Internet: mounting attachment		
	For size	Remarks	Order code	Part No.	Type	PU ¹⁾
Slot nut NST						
	18, 25	For mounting slot/profile slot	Y	526 091	NST-HMV-M4	1
	40			150 914	NST-5-M5	1
	63			150 915	NST-8-M6	1
	HD18, HD25	For heavy-duty guide: mounting slot	Y	150 914	NST-5-M5	1
	HD40			150 915	NST-8-M6	1
	HD18	For heavy-duty guide: HD underneath	U	150 914	NST-5-M5	1
	HD25, HD40			150 915	NST-8-M6	1
Slot nut NSTL						
	25	For slide	X	158 410	NSTL-25	1
	40			158 412	NSTL-40	1
	63			158 414	NSTL-63	1
	HD18	For heavy-duty guide: slide	X	161 020	NSTH-18	1
	HD25			161 021	NSTH-25	1
	HD40			161 022	NSTH-40	1
Centring pin/sleeve ZBS/ZBH						
	8 ... 18	For slide	Z	150 928	ZBS-5	10
	25 ... 63			150 927	ZBH-9	10
Central mounting SLZZ						
	HD18	For heavy-duty guide: slide	Q	150 901	SLZZ-25/16	1
	HD25					
	HD40					
Slot cover ABP						
	40	For mounting slot each 0.5 m	B	151 681	ABP-5	2
	63			151 682	ABP-8	
	HD18, HD25	For mounting slot at side and underneath, each 0.5 m		151 681	ABP-5	
	HD40			151 682	ABP-8	
Slot cover ABP-S						
	8 ... 63	For sensor slot each 0.5 m	S	151 680	ABP-5-S	2
	25	For mounting slot for DGE-ZR-RF	B			



1) Packaging unit quantity



Toothed belt axes DGE



Accessories

FESTO

Ordering data – Proximity sensors for T-slot, magneto-resistive						Technical data → Internet: smt	
	Type of mounting	Switch output	Electrical connection	Cable length [m]	Part No.	Type	
N/O contact							
	Insertable in the slot lengthwise, flush with the cylinder profile	PNP	Cable, 3-wire	2.5	175 436	SMT-8-PS-K-LED-24-B	
			Plug M8x1, 3-pin	0.3	175 484	SMT-8-PS-S-LED-24-B	
N/C contact							
	Insertable in the slot from above, flush with cylinder profile	PNP	Cable, 3-wire	7.5	543 873	SMT-8M-PO-24V-K7,5-OE	

Ordering data – Proximity sensors for T-slot, magnetic reed						Technical data → Internet: sme	
	Type of mounting	Switch output	Electrical connection	Cable length [m]	Part No.	Type	
N/O contact							
	Insertable in the slot lengthwise, flush with the cylinder profile	Contacting	Cable, 3-wire	2.5	150 855	SME-8-K-LED-24	
			Plug M8x1, 3-pin	0.3	150 857	SME-8-S-LED-24	
N/C contact							
	Insertable in the slot lengthwise, flush with the cylinder profile	Contacting	Cable, 3-wire	7.5	160 251	SME-8-O-K-LED-24	

Ordering data – Inductive proximity sensors M8						Technical data → Internet: sien	
	Electrical connection		Switch output	LED	Cable length [m]	Part No.	Type
	Cable	Plug M8					
NO contact							
	3-wire	–	PNP	■	2.5	150 386	SIEN-M8B-PS-K-L
	–	3-pin	PNP	■		150 387	SIEN-M8B-PS-S-L
NC contact							
	3-wire	–	PNP	■	2.5	150 390	SIEN-M8B-PO-K-L
	–	3-pin	PNP	■		150 391	SIEN-M8B-PO-S-L

Ordering data – Connecting cables				Technical data → Internet: nebu	
	Electrical connection, left	Electrical connection, right	Cable length [m]	Part No.	Type
	Straight socket, M8x1, 3-pin	Cable, open end, 3-wire	2.5	541 333	NEBU-M8G3-K-2.5-LE3
			5	541 334	NEBU-M8G3-K-5-LE3
	Angled socket, M8x1, 3-pin	Cable, open end, 3-wire	2.5	541 338	NEBU-M8W3-K-2.5-LE3
			5	541 341	NEBU-M8W3-K-5-LE3