

Spindle axes DGE



Spindle axes DGE

Key features

FESTO

At a glance

- Precision, rigid guide
- Highly adaptable, thanks to wide choice of mounting and attachment options
- Wide range of options for attaching drive units
- Comprehensive range of mounting accessories for multi-axis combinations
- Optimally adapted motor controller combinations

Basic version DGE-SP

- Stroke lengths from 100 ... 2000 mm
- Without guide
- Low characteristic load values



With recirculating ball bearing guide DGE-SP-KF-GK/-GV

- Stroke lengths from 100 ... 2000 mm
- Standard slide or extended slide
- Medium to high characteristic load values



With protected version DGE-SP-KF-GA

- Stroke lengths from 140 ... 1500 mm
- Guide and slide are fitted with a cover to protect against the ingress of particles from above and from the side



With heavy-duty guide DGE-SP-HD

- Stroke lengths from 100 ... 1500 mm
- High guide precision
- Sturdy construction
- High characteristic load values



Spindle axes DGE

Key features

System selection for electromechanical drives

Spindle axis



-  - Note

For the spindle axes and the motors there are matching complete solutions.

Motor kit

Axial kit

Parallel kit

→ 54



Axial kit consisting of:

- Motor flange
- Coupling housing
- Coupling
- Screws

Motor

→ 54



- 1 Servo motor EMMS-AS
- 2 Stepper motor EMMS-ST

Motor controller

Technical data → Internet: motor controller



- 1 Servo motor ontroller CMMP-AS, CMMS-AS
- 2 Stepper motor controller CMMS-ST

Spindle axes DGE

System example

FESTO

System product for handling and assembly technology

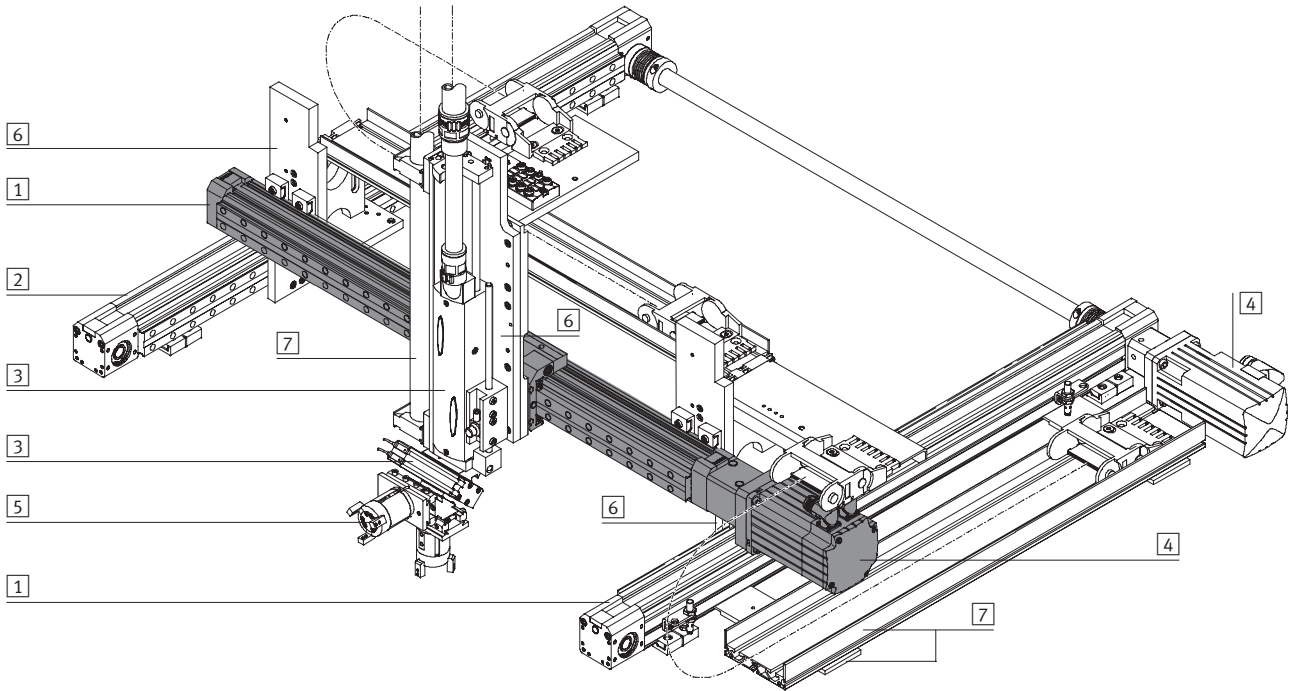

System components and accessories

Type	Brief description	→ Page/Internet
1 Axes	Wide range of combination options within handling and assembly technology	axes
2 Passive guide axes	Diverse possible combinations in handling and assembly technology	guide axes
3 Drives	Wide range of combination options within handling and assembly technology	drive
4 Motors	Servo and stepper motors, with or without gearing	motor
5 Grippers	Wide range of combination options within handling and assembly technology	gripper
6 Adapters	For combining drives with drives and drives with grippers	adapter kit
7 Installation components	For achieving a clear-cut, safe layout for electrical cables and tubing	installation component

Spindle axes DGE

Selection aid

Guide characteristics

The data in the table are maximum values. The precise values for each variant can be found in the corresponding data sheet included in the catalogue.

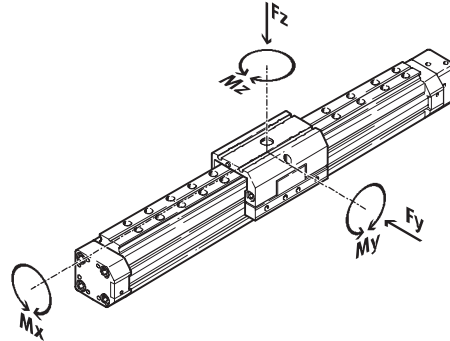

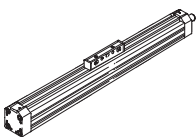
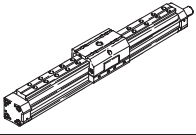
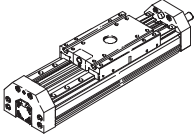
Version	Size	Working stroke [mm]	Speed [m/s]	Repetition accuracy [mm]	Feed force [N]	Forces and torques					→ Page/Internet
						Fy [N]	Fz [N]	Mx [Nm]	My [Nm]	Mz [Nm]	
Basic version without guide SP											
	18	100 ... 500	0.2	±0.02	140	–	1.8	0.5	0.8	0.8	6
	25	100 ... 1000	0.5	±0.02	250	–	2	1	1.5	1.5	
	40	200 ... 1500	1	±0.02	600	–	15	4	4	4	
	63	300 ... 2000	1.2	±0.02	1600	–	106	8	18	18	
With recirculating ball bearing guide SP-KF											
	18	100 ... 500	0.2	±0.02	140	930	930	7	45	45	20
	25	100 ... 1000	0.5	±0.02	250	3080	3080	45	170	170	
	40	140 ... 1500	1	±0.02	600	7300	7300	170	660	660	
	63	150 ... 2000	1.2	±0.02	1600	14050	14050	580	1820	1820	
With heavy-duty guide SP-HD											
	18	100 ... 400	0.2	±0.02	140	1820	1820	70	115	112	42
	25	100 ... 900	0.5	±0.02	250	5400	5600	260	415	400	
	40	200 ... 1500	1	±0.02	600	5400	5600	375	560	540	

Spindle axes DGE-SP

Peripherals overview

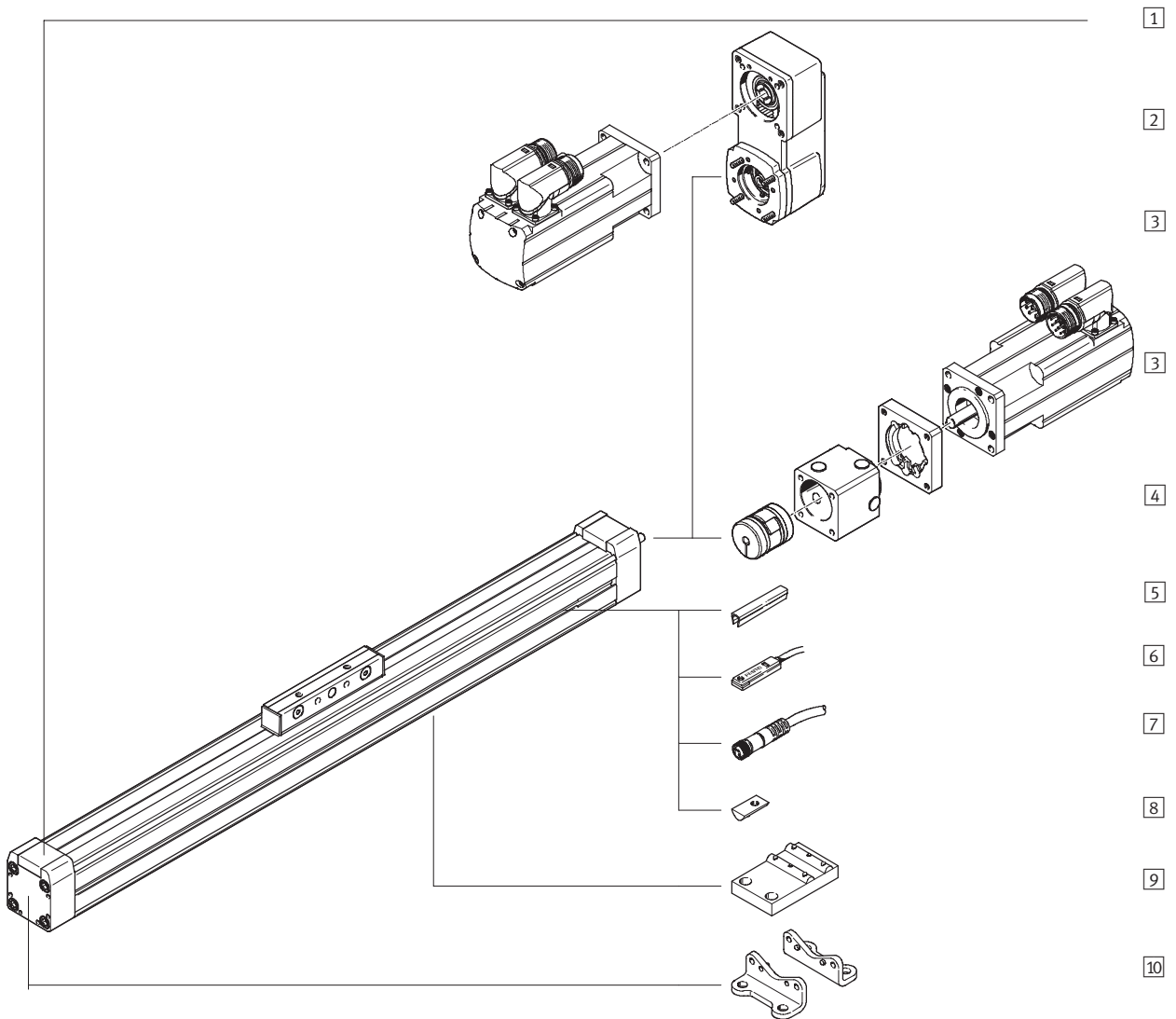

Spindle axes DGE-SP

Peripherals overview

Variants and accessories		
Type	Brief description	→ Page/Internet
1 Spindle axis DGE-SP	Electromechanical axis without guide	8
2 Parallel kit EAMM-U	For parallel motor attachment (consisting of: housing, Clamping component, clamping sleeve, toothed belt gearwheel, toothed belt)	57
3 Motor EMMS	Motors specially matched to the axis, with or without gearing, with or without brake	54
4 Axial kit EAMM-A	For axial motor attachment (consisting of: coupling housing, clamping component, motor flange)	54
5 Slot cover B/S	For protecting against the ingress of dirt	68
6 Proximity sensor G/H/I/J/N	For use as a signal generator and safety monitoring	69
7 Cable with socket V	For proximity sensors	69
8 Slot nut for mounting slot Y	For mounting attachments	68
9 Central support M	For mounting the axis	61
10 Foot mounting F	For mounting the axis	61

Spindle axes DGE-SP

Type code

		DGE	-	25	-	500	-	SP	+ZUB	-					F	2G	
Type																	
DGE	Spindle axis																
Size																	
Stroke [mm]																	
Drive function																	
SP	Spindle																
Accessories																	
ZUB	Accessories supplied loos																
Slot cover																	
...S	Sensor slot																
...B	Mounting slot																
Slot nut																	
...Y	For mounting slot																
Central support																	
...M	Central support																
Foot mounting																	
...F	Foot mounting																
Proximity sensor																	
...G	With cable, 2.5 m																
...H	With plug																
...I	Contactless with cable, 2.5 m																
...J	Contactless, plug																
...N	NC contact with cable, 2.5 m																
Cable with socket																	
...V	2.5 m																

Spindle axes DGE-SP

Technical data

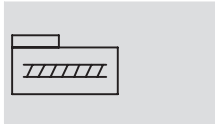

FESTO

Function

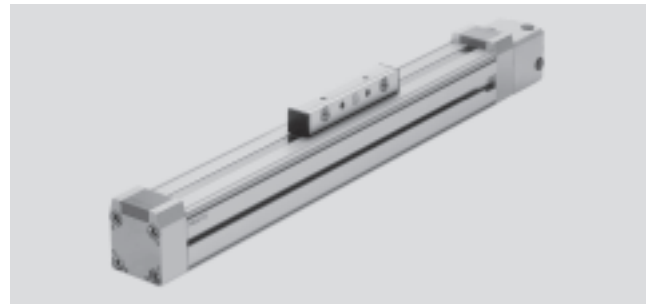

 www.festo.com



-  Size
18 ... 63
-  Stroke length
100 ... 2000 mm

General technical data					
Size		18	25	40	63
Constructional design		Electromechanical axis with spindle and driver			
Guide		-			
Mounting position		Any			
Max. working stroke ¹⁾	[mm]	100 ... 500	100 ... 1000 ⁴⁾	200 ... 1500 ⁴⁾	300 ... 2000 ⁴⁾
Max. feed force F_x	[N]	140	250	600	1600
Max. driving torque	[Nm]	0.1	0.45	2.1	8.5
Max. no-load driving torque ²⁾	[Nm]	0.05	0.15	0.33	1.15
Max. radial force ³⁾	[N]	40	75	250	800
Max. speed ⁴⁾	[m/s]	0.2	0.5	1	1.2
Max. acceleration	[m/s ²]	6			
Repetition accuracy	[mm]	±0.02			

- 1) Total stroke = working stroke + 2x stroke reserve
- 2) Measured at a speed of 0.2 m/s
- 3) On drive shaft
- 4) The maximum speed is dependent on the stroke length → 13

Operating and environmental conditions					
Size		18	25	40	63
Ambient temperature	[°C]	0 ... +40			
Protection class		IP40			

Weights [kg]					
Size		18	25	40	63
Basic weight with 0 mm stroke ¹⁾		0.55	1.4	4.3	12.5
Additional weight per 100 mm stroke		0.21	0.41	0.71	2.53
Moving load		0,13	0,25	0,67	2,17

- 1) Including coupling housing

Mass moment of inertia					
Size		18	25	40	63
J_0	[kg cm ²]	0.007	0.029	0.364	3.15
J_H per metre stroke	[kg cm ² /m]	0.031	0.121	1	6.67
J_L per kg working load	[kg cm ² /kg]	0.005	0.025	0.101	0.228

The mass moment of inertia J_A of the entire axis is calculated as follows:

$$J_A = J_0 + J_H \times \text{working stroke [m]} + J_L \times m_{\text{working load [kg]}}$$

Spindle axes DGE-SP

Technical data

FESTO

Spindle					
Size		18	25	40	63
Diameter	[mm]	8	12	20	32
Pitch	[mm/rev.]	4	10	20	30

Materials

Sectional view

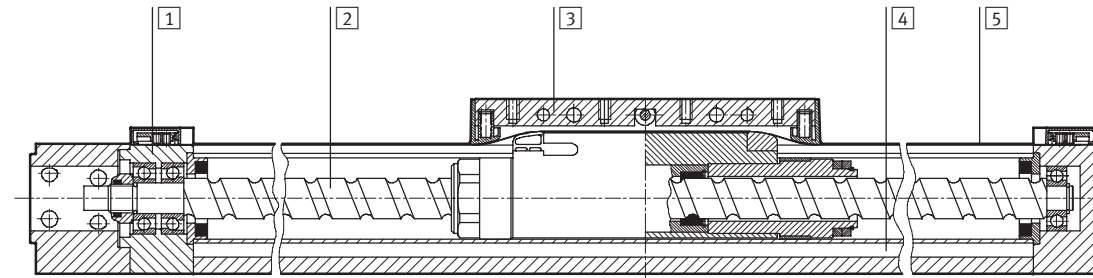

Axis		
1	End cap	Wrought aluminium alloy, anodised
2	Spindle	Rolled steel
3	Driver	Wrought aluminium alloy, anodised
4	Profile	Wrought aluminium alloy, anodised
5	Cover strip	Corrosion resistant steel

Stroke reserve

L1+ Overall length of axis
L11 Internal mechanical stop

1 The working stroke is the effective usable work range. Please quote this in your order.

L12 Stroke reserve:
Safety distance to mechanical stop, present at both ends of the axis in addition to the stroke.

Example:
Type DGE-25-500-SP
Working stroke = 500 mm
Stroke reserve = (2x 10 mm)
= 20 mm
Total stroke
520 mm = 500 mm + 20 mm

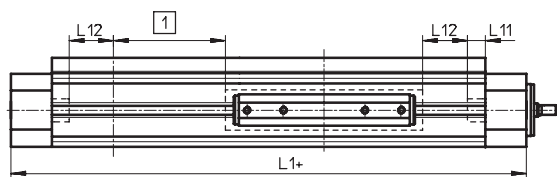

Size		18	25	40	63
L12 per end position	[mm]	6.5	10	20	30

Spindle axes DGE-SP

Technical data

Characteristic load values

The indicated forces and torques refer to the centre line of the internal diameter of the profile.

They must not be exceeded in the dynamic range. Special attention must be paid to the cushioning phase.

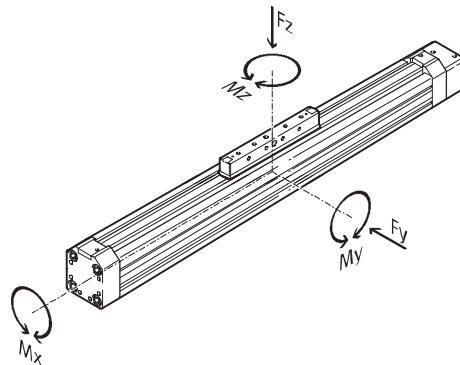

If the axis is subjected to more than two of the indicated forces and torques simultaneously, the following equations must be satisfied in addition to the indicated maximum loads:

$$\frac{Fz}{Fz_{max.}} + \frac{My}{My_{max.}} + \frac{Mz}{Mz_{max.}} \leq 1$$

$$\frac{Mx}{Mx_{max.}} \leq 1$$

Permissible forces and torques					
Size		18	25	40	63
Fy _{max.}	[N]	–	–	–	–
Fz _{max.}	[N]	1.8	2	15	106
Mx _{max.}	[Nm]	0.5	1	4	8
My _{max.}	[Nm]	0.8	1.5	4	18
Mz _{max.}	[Nm]	0.8	1.5	4	18

2nd moment of area

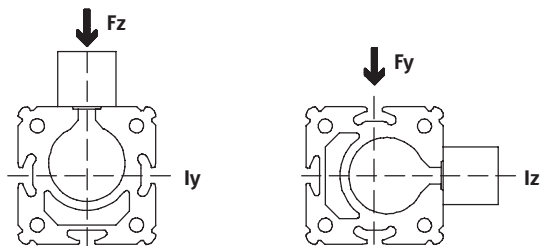

Size		18	25	40	63
Iy	[mm ⁴]	69.8x10 ³	224x10 ³	673x10 ³	5688x10 ³
Iz	[mm ⁴]	72.3x10 ³	240x10 ³	748x10 ³	6031x10 ³

 Note
 Sizing software
 PositioningDrives
www.festo.com

Spindle axes DGE-SP

Technical data

Maximum permissible support span l as a function of the force F

The axis may need to be supported with central supports in order to restrict deflection with long stroke lengths. The following diagrams serve to determine the maximum permissible support span l as a function of the force acting upon the axis F .

1 Force on the surface of the driver

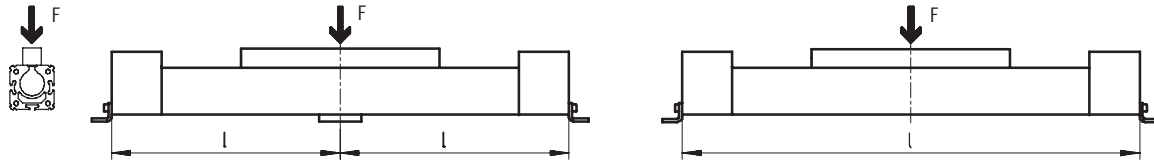

2 Force on the front of the driver

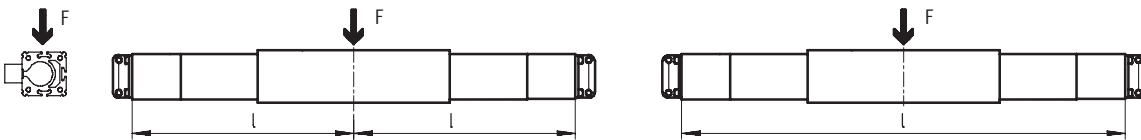

Maximum permissible support span l (without central support) as a function of the force F

DGE-18

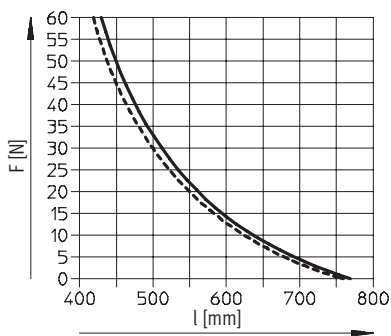

DGE-25

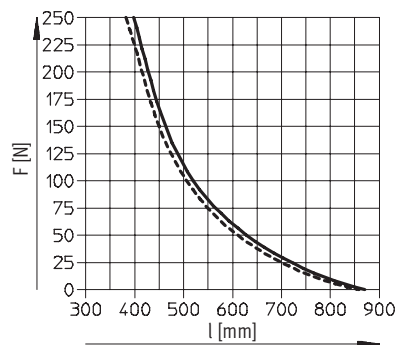

DGE-40

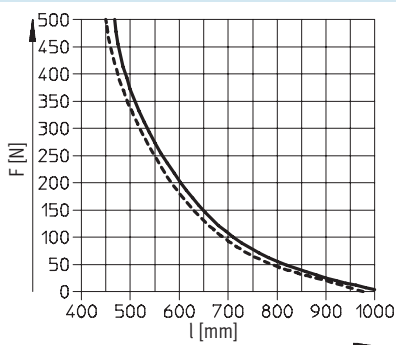

DGE-63

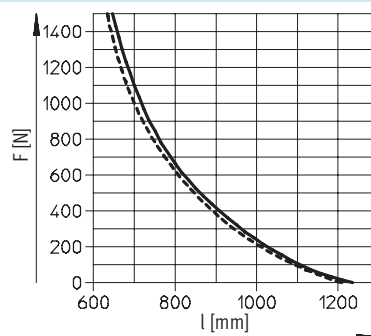

— 1
- - - 2

Spindle axes DGE-SP

Technical data

Maximum permissible speed v or drive rpm n as a function of the stroke l

DGE-18

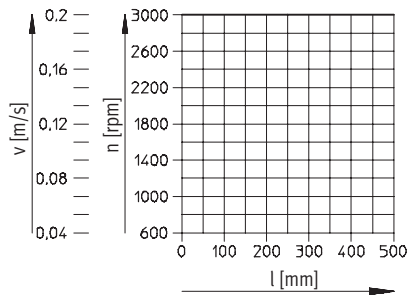

DGE-25

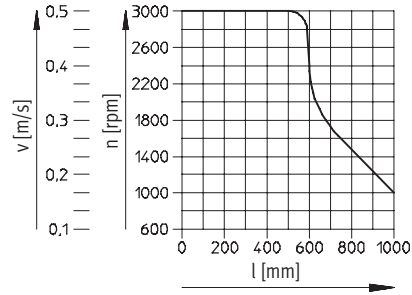

DGE-40

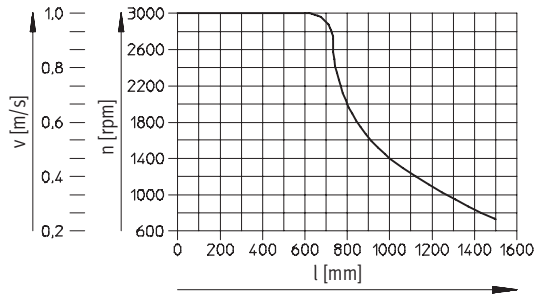

DGE-63

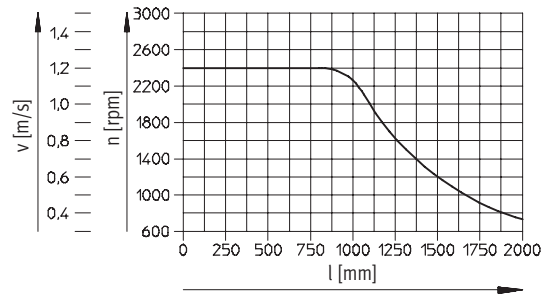

Spindle axes DGE-SP

Technical data

FESTO

Dimensions

Download CAD data → www.festo.com

Size 18

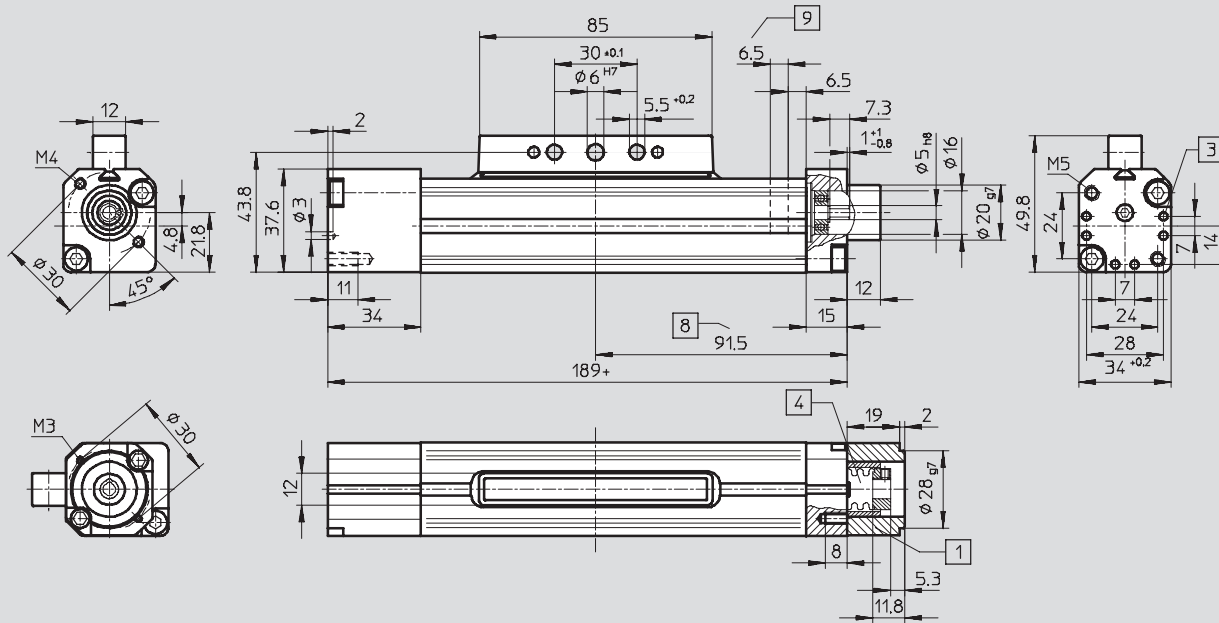

- 1 Coupling housing
 - 2 Sensor slot for proximity sensor
 - 3 Centring hole for foot mounting HP
 - 4 Coupling
 - 8 Driver in end position of working stroke (stroke reserve up to mechanical stop still present)
 - 9 Stroke reserve → 10
- + = plus stroke length

Profile

Size 18

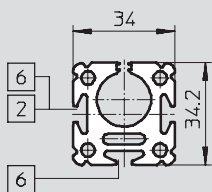

- 2 Sensor slot for proximity sensor
- 6 Mounting slot for slot nut NST

Spindle axes DGE-SP

Technical data

Dimensions

Download CAD data → www.festo.com

Size 25 ... 63

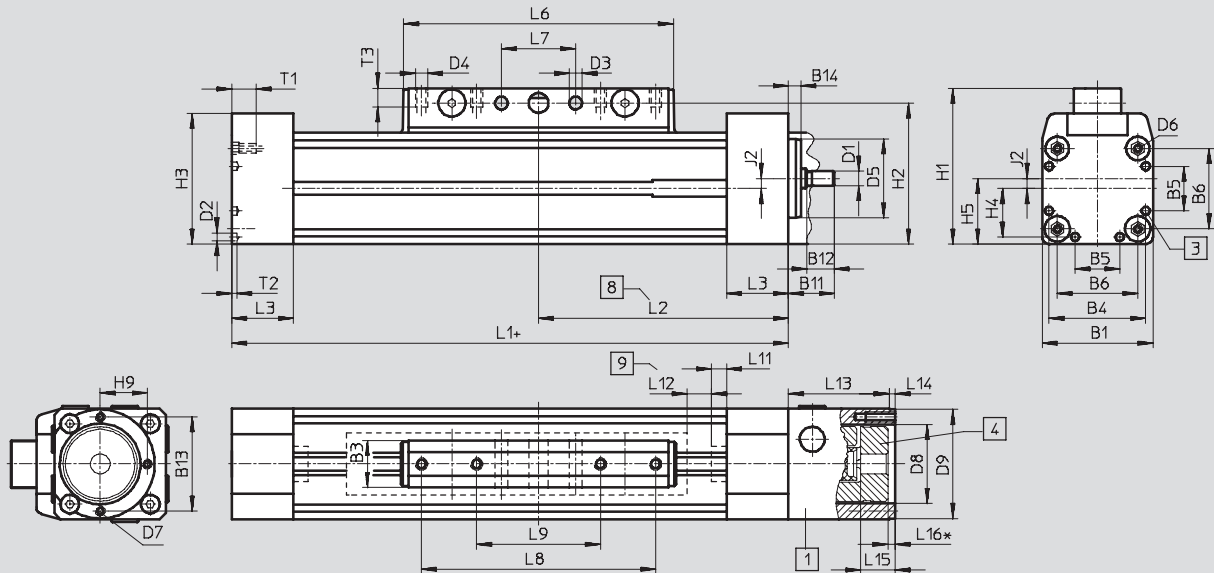

- 1 Coupling housing
- 3 Centring hole for foot mounting HP
- 4 Coupling
- 8 Driver in end position of working stroke (stroke reserve up to mechanical stop still present)
- 9 Stroke reserve → 10 + = plus stroke length

Profile

Size 25

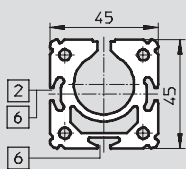

Size 40

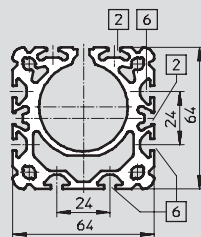

Size 63

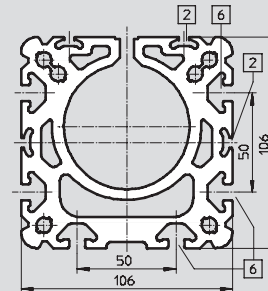

- 2 Sensor slot for proximity sensor
- 6 Mounting slot for slot nut NST

Size	B1	B3	B4	B5	B6	B11	B12	B13	B14	D1	D2	D3	D4	D5	D6	D7	D8	D9	H1	H2	H3
25	45	19 +0.2	39.1	18	32.5	18.5	11	38	4	6	3.3	5.2	M5	32	M4	M4	32	44	63	57	52.8
40	64	21	53	28	49	22.5	12	38	5	12	4.4	6.5	M6	48	M5	M4	32	44	86	78	71.8
63	106	24	89	44	83	47.5	25	56	7	20	6.4	8.5	M8	72	M8	M6	48	64	131	122	115

Size	H4	H5	H9	J2	L1	L2	L3	L6	L7	L8	L9	L11	L12	L13	L14	L15	L16 ¹⁾	T1	T2	T3	
25	19.6	26.5	19	4	213	101.5	25	109	30	±0.1	±0.1	±0.1	6	10	43	2.5	14	3	13	2	7.5
40	26.5	37	19	5	315	153	31	171	70	130	40	7	20	46	3	14.5	3.5	13	3	10.5	
63	44.5	61	28	8	410	200	36	234	110	190	70	9	30	83	4	23	-2	21	4	12.5	

1) Negative dimension: Protrudes beyond coupling housing

Spindle axes DGE-SP

Ordering data – Modular products

Order code

Mandatory data

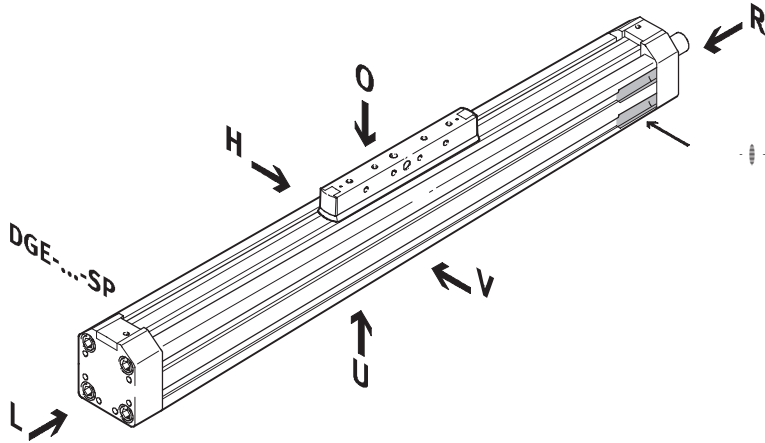

-  - Note

The insertion point for the proximity sensor is located on the right-hand side of the spindle axis DGE-...-SP

- O top
- U underneath
- V front
- H rear
- R right
- L left

Spindle axes DGE-SP

Ordering data – Modular products

Order code

Options

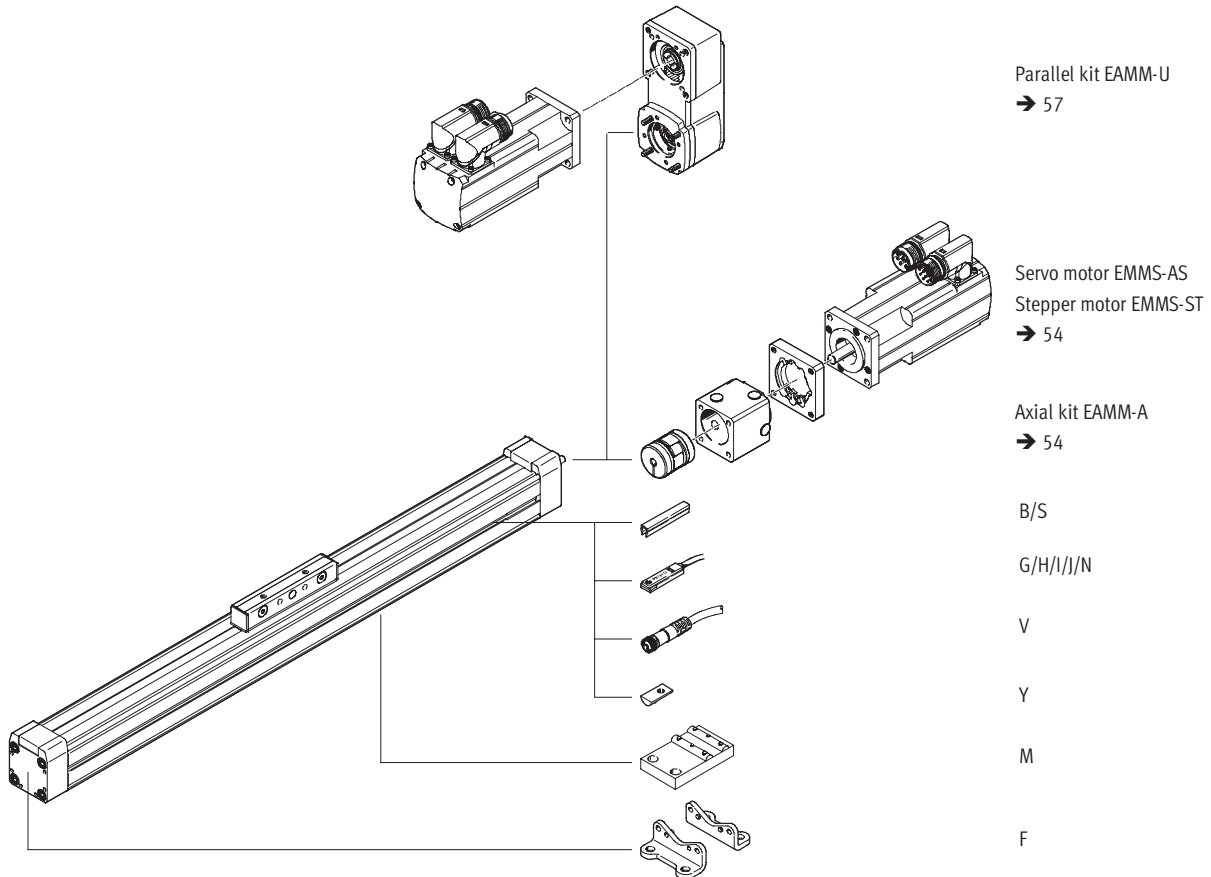

Spindle axes DGE-SP

Ordering data – Modular products



M Mandatory data →

Module No.	Design	Size	Stroke	Drive function
193 745	DGE	18	1 ... 2 000	SP
193 746		25		
193 747		40		
193 748		63		
Ordering example				
193 747	DGE	40	800	SP

Ordering table

Size	18	25	40	63	Condi- tions	Code	Enter code
M Module No.	193 745	193 746	193 747	193 748			
Design	Electromechanical linear axis					DGE	DGE
Size	18	25	40	63		-...	
Stroke [mm]	100, 200, 300, 400, 500	100, 200, 300, 400, 500, 600, 700, 800, 900, 1000	200, 300, 400, 500, 600, 800, 1000, 1200, 1400, 1500	300, 400, 500, 600, 800, 1000, 1200, 1400, 1500, 1800, 2000		-...	
	-	1 ... 990	1 ... 1487	1 ... 1982			
Drive function	Electromechanical drive with ball screw					-SP	-SP

Transfer order code

	DGE				SP
--	------------	--	--	--	-----------

Spindle axes DGE-SP

Ordering data – Modular products



Options						
Accessories	Slot cover	Slot nut	Central support	Foot mounting	Proximity sensor	Plug socket
ZUB	...S ...B	...Y	...M	...F	...G ...H ...I ...J ...N	...V
ZUB	- 2S2B	10Y		F	2G	

Ordering table								
Size	18	25	40	63	Condi- tions	Code	Enter code	
↓ Accessories	Supplied separately						ZUB-	ZUB-
[O] Slot cover	Sensor slot	1 ... 10				...S		
	Mounting slot	-	-	1 ... 10		...B		
Slot nut	for mounting slot		1 ... 10			...Y		
Central support	1 ... 10					...M		
Foot mounting (kit)	1 ... 10					...F		
Proximity sensor	with cable, 2.5 m	1 ... 10				...G		
	with plug	1 ... 10				...H		
	contactless with cable, 2.5 m	1 ... 10				...I		
	contactless, plug	1 ... 10				...J		
	NC contact with cable, 2.5 m	1 ... 10				...N		
Cable with socket, 2.5 m	1 ... 10					...V		

Transfer order code

ZUB	-						
-----	---	--	--	--	--	--	--

Spindle axes DGE-SP-KF, with recirculating ball bearing guide

Peripherals overview

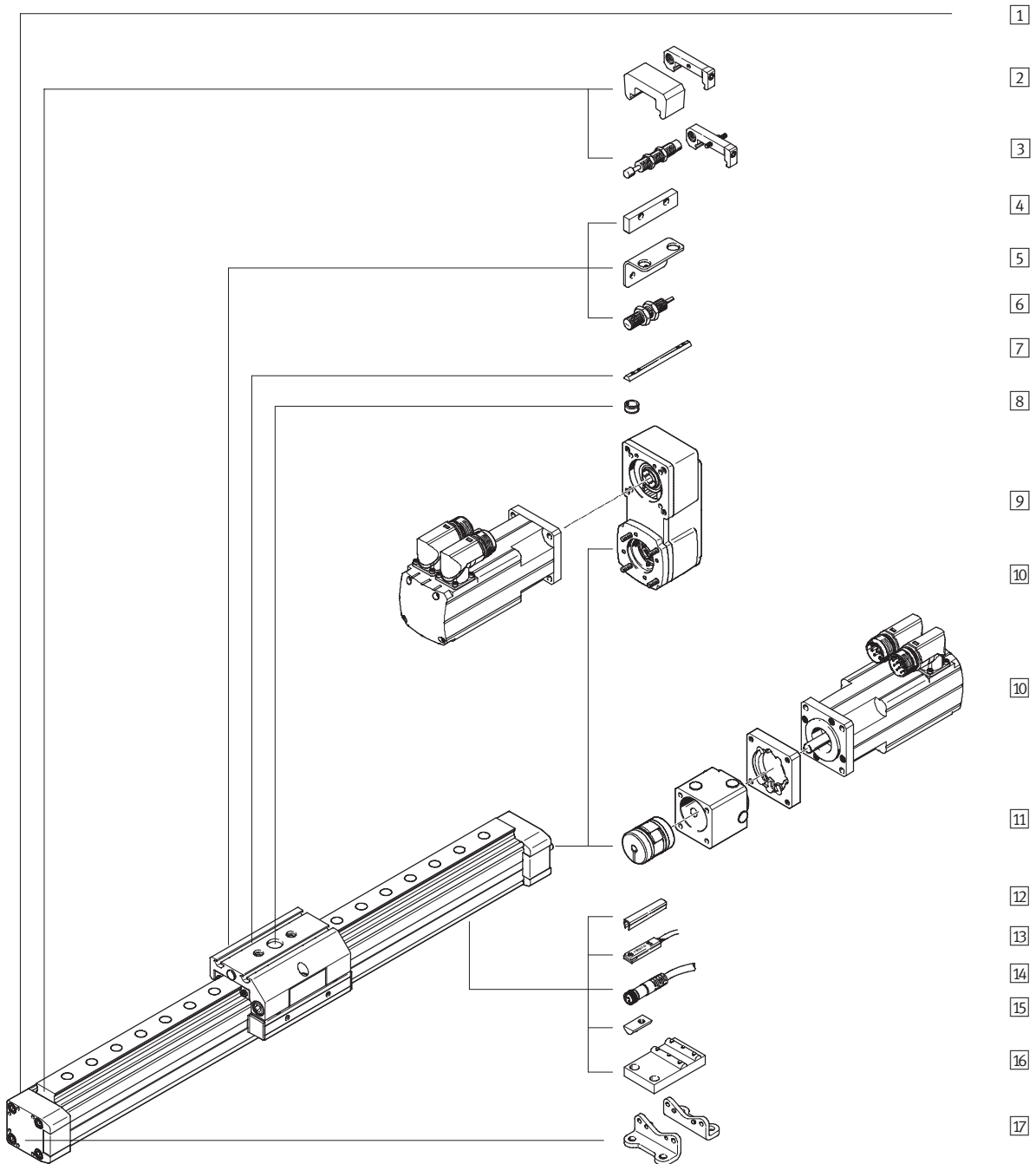
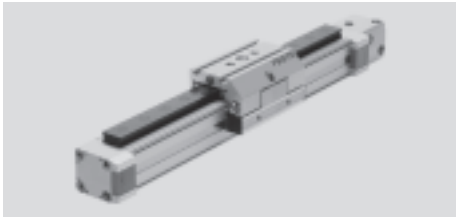

Spindle axes DGE-SP-KF, with recirculating ball bearing guide

Peripherals overview

Variants and accessories					
Type	Brief description	GK/GV	GA	→ Page/Internet	
1 Spindle axis DGE-SP-KF	Electromechanical axis with spindle and recirculating ball bearing guide	■	■	22	
2 Emergency buffer with retainer ¹⁾ A	For avoiding damage at the end stop in the event of malfunction	■	■	64	
3 Shock absorber kit C	For avoiding damage at the end stop in the event of malfunction	■	-	63	
3 Shock absorber kit E	For avoiding damage at the end stop in the event of malfunction	-	■	64	
4 Switching lug L	For sensing the slide position	■	-	66	
5 Sensor bracket T	Adapter for mounting the inductive proximity sensors on the axis	■	-	66	
6 Inductive proximity sensor O/P/R/W	For use as a signal generator and safety monitoring	■	-	69	
7 Slot nut for slide X	For mounting loads and attachments on the slide	■	■	68	
8 Centring pins/sleeves Z	For centring loads and attachments on the slide	■	■	68	
9 Parallel kit EAMM-U	For parallel motor attachment (consisting of: housing, Clamping component, clamping sleeve, toothed belt gearwheel, toothed belt)	■	■	57	
10 Motor EMMS	Motors specially matched to the axis, with or without gearing, with or without brake	■	■	54	
11 Axial kit EAMM-A	For axial motor attachment (consisting of: coupling housing, clamping component, motor flange)	■	■	54	
12 Slot cover B/S	For protecting against the ingress of dirt	■	■	68	
13 Proximity sensor G/H/I/J/N	For use as a signal or safety check	■	■	69	
14 Cable with socket V	For proximity sensors	■	■	69	
15 Slot nut for mounting slot Y	For mounting attachments	■	■	68	
16 Central support M	For mounting the axis	■	■	61	
17 Foot mounting F	For mounting the axis	■	■	61	

1) Fitted as standard for GV and GA.

Spindle axes DGE-SP-KF, with recirculating ball bearing guide

Type code

	DGE	-	25	-	500	-	SP	-	KF	-	GK	-	SV	-	
Type															
DGE	Spindle axis														
Size															
Stroke [mm]															
Drive function															
SP	Spindle														
Guide															
KF	Recirculating ball bearing guide														
Slide															
GK	Standard slide														
GV	Extended slide														
GA	Protected version														
Slide attachment position															
SV	At front														
SH	At rear														
Additional slide															
KL	Left														
KR	Right														

Spindle axes DGE-SP-KF, with recirculating ball bearing guide

Type code

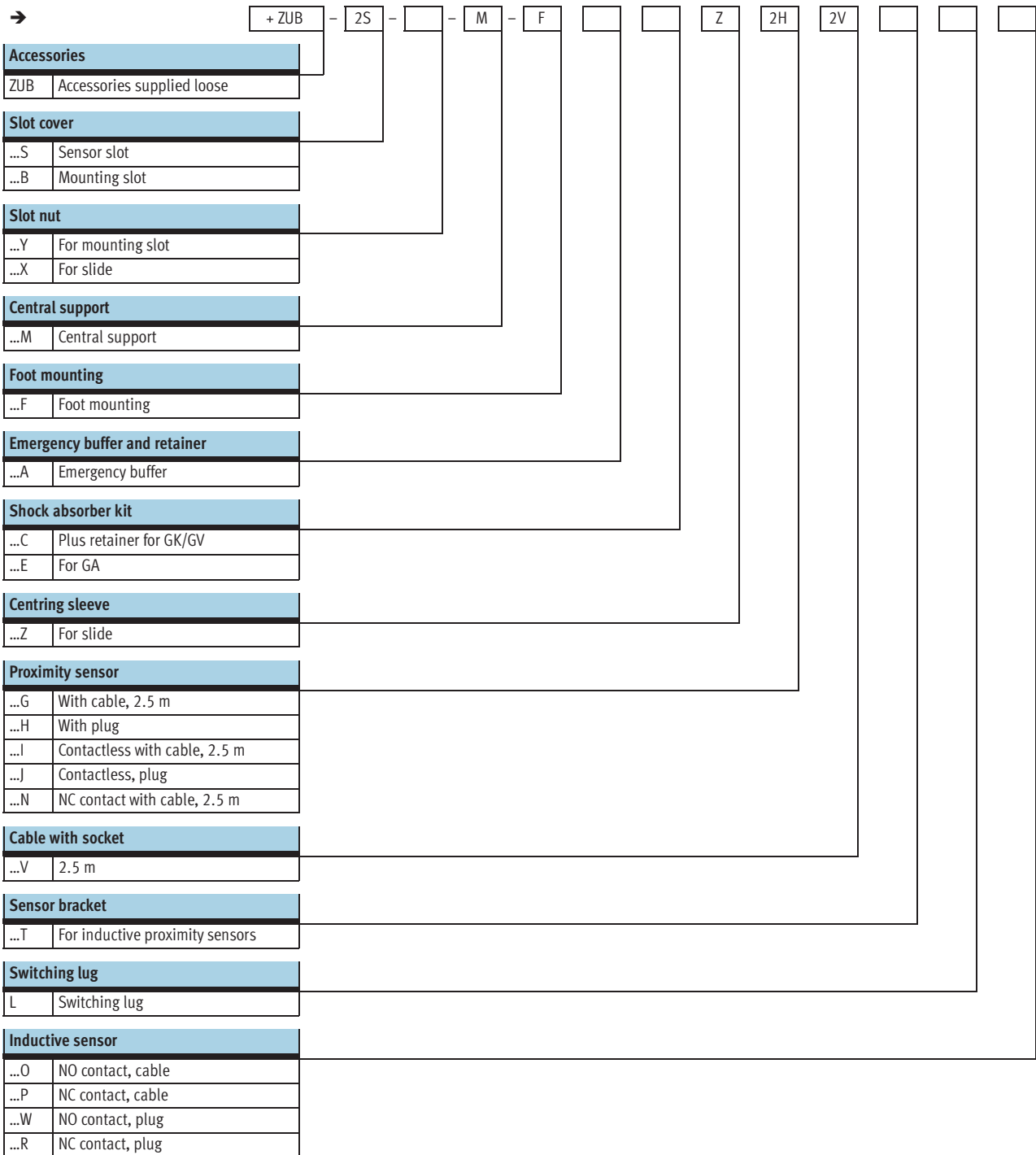

Spindle axes DGE-SP-KF, with recirculating ball bearing guide

FESTO

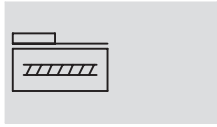

Technical data

Function

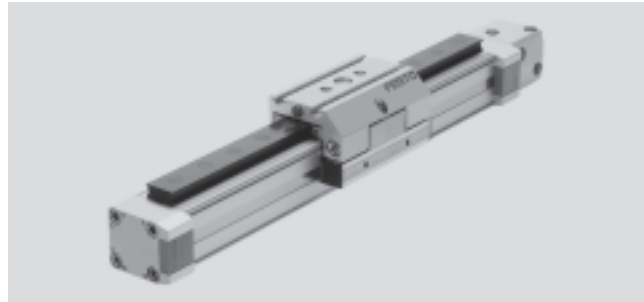

 www.festo.com



-  Size
18 ... 63
-  Stroke length
100 ... 2000 mm

General technical data		18	25	40	63
Size		18	25	40	63
Constructional design	Electromechanical axis with spindle and recirculating ball bearing guide				
Guide	Recirculating ball bearing guide				
Mounting position	Any				
Max. working stroke ¹⁾	GK [mm]	100 ... 500	100 ... 1000 ⁴⁾	200 ... 1500 ⁴⁾	300 ... 2000 ⁴⁾
	GV [mm]	110 ... 410	170 ... 870 ⁴⁾	170 ... 1270 ⁴⁾	150 ... 1650 ⁴⁾
	GA [mm]	–	170 ... 970 ⁴⁾	140 ... 1440 ⁴⁾	–
Max. working load	[kg]	6	25	50	150
Max. feed force F_x	[N]	140	250	600	1600
Max. driving torque	[Nm]	0.1	0.45	2.1	8.5
Max. no-load driving torque ²⁾	[Nm]	0.05	0.15	0.33	1.15
Max. radial force ³⁾	[N]	40	75	250	800
Max. speed ⁴⁾	[m/s]	0.2	0.5	1	1.2
Max. acceleration	[m/s ²]	6			
Repetition accuracy	[mm]	±0.02			

- 1) Total stroke = working stroke + 2x stroke reserve → 28
- 2) Measured at a speed of 0.2 m/s
- 3) On drive shaft
- 4) The maximum speed is dependent on the stroke length → 30

Operating and environmental conditions		18	25	40	63
Size		18	25	40	63
Ambient temperature	[°C]	0 ... +40			
Protection class		IP40			

Weights [kg]		18	25	40	63
Basic weight with 0 mm stroke ¹⁾	GK	1	2.1	6.4	18.1
	GV	1.52	3.26	10.04	32.2
	GA	–	3.1	8.97	–
Additional weight per 100 mm stroke	GK	0.3	0.56	1.14	3.31
	GV	0.3	0.56	1.14	3.31
	GA	–	0.65	1.26	–
Moving load	GK	0,45	0,68	1,82	5,38
	GV	0,61	0,94	2,54	7,84
	GA	–	1,24	3,19	–
Additional slide	KL/KR	0.25	0.38	1.06	3.1

- 1) Including coupling housing and slide

Spindle axes DGE-SP-KF, with recirculating ball bearing guide

Technical data

Mass moment of inertia						
Size		18	25	40	63	
J ₀	GK	[kg cm ²]	0.008	0.04	0.48	3.88
	GV	[kg cm ²]	0.0117	0.0617	0.782	6.77
	GA	[kg cm ²]	–	0.0573	0.678	–
J _H per metre stroke		[kg cm ² /m]	0.031	0.121	1	6.67
J _L per kg working load		[kg cm ² /kg]	0.005	0.025	0.101	0.228
J _W for additional slide		[kg cm ²]	0.001	0.0096	0.107	0.707

The mass moment of inertia J_A of the entire axis is calculated as follows:

$$J_A = J_0 + J_H \times \text{working stroke [m]} + J_L \times m_{\text{working load [kg]}}$$

Spindle					
Size		18	25	40	63
Diameter	[mm]	8	12	20	32
Pitch	[mm/rev.]	4	10	20	30

Materials

Sectional view

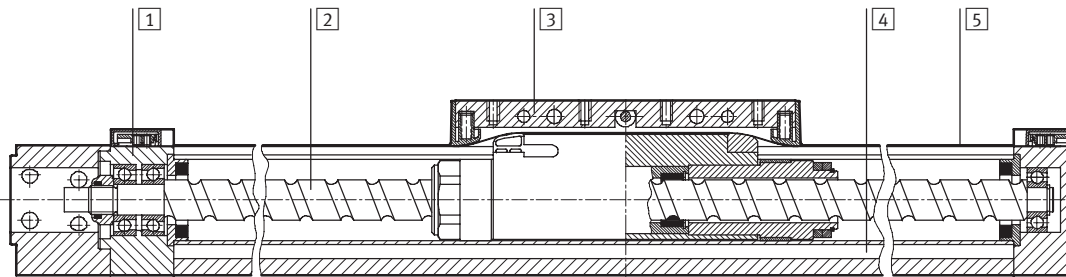

Axis		
1	End cap	Wrought aluminium alloy, anodised
2	Spindle	Rolled steel
3	Slide	Wrought aluminium alloy, anodised
4	Profile	Wrought aluminium alloy, anodised
5	Cover strip	Corrosion resistant steel

Spindle axes DGE-SP-KF, with recirculating ball bearing guide

Technical data



Characteristic load values for axis with standard slide GK or protected version GA

The indicated forces and torques refer to the centre of the guide rail. They must not be exceeded in the dynamic range. Special attention must be paid to the cushioning phase.

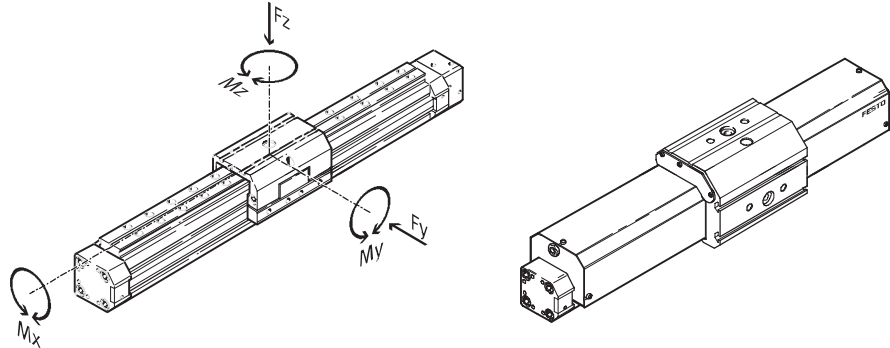

If the drive is subjected to more than two of the indicated forces and torques simultaneously, the following equations must be satisfied in addition to the indicated maximum loads:

$$\frac{F_y}{F_{y_{max}}} + \frac{F_z}{F_{z_{max}}} + \frac{M_x}{M_{x_{max}}} + \frac{M_y}{M_{y_{max}}} + \frac{M_z}{M_{z_{max}}} \leq 1$$

Permissible forces and torques GK/-GA					
Size		18	25	40	63
F _y _{max.}	[N]	930	3080	7300	14050
F _z _{max.}	[N]	930	3080	7300	14050
M _x _{max.}	[Nm]	7	45	170	580
M _y _{max.}	[Nm]	23	85	330	910
M _z _{max.}	[Nm]	23	85	330	910

2nd moment of area

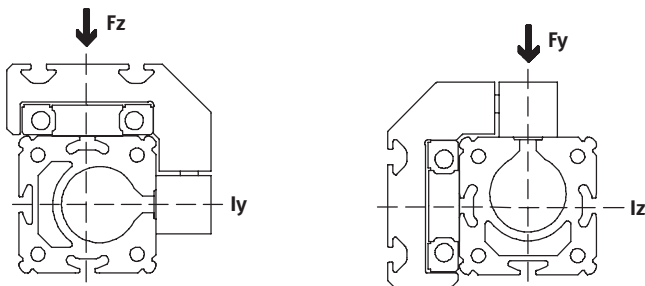

Size		18	25	40	63
l _y	[mm ⁴]	172.3x10 ³	551x10 ³	1908x10 ³	13677x10 ³
l _z	[mm ⁴]	73.7x10 ³	250x10 ³	875x10 ³	6987x10 ³

- - Note

Sizing software
PositioningDrives
→ www.festo.com

Spindle axes DGE-SP-KF, with recirculating ball bearing guide

Technical data

Characteristic load values for axis with extended slide GV

The indicated forces and torques refer to the centre of the guide rail. They must not be exceeded in the dynamic range. Special attention must be paid to the cushioning phase.

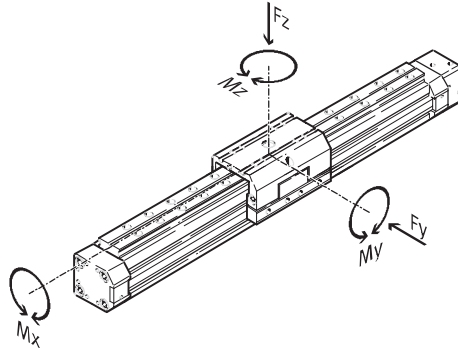

If the drive is subjected to more than two of the indicated forces and torques simultaneously, the following equations must be satisfied in addition to the indicated maximum loads:

$$\frac{F_y}{F_{y_{max}}} + \frac{F_z}{F_{z_{max}}} + \frac{M_x}{M_{x_{max}}} + \frac{M_y}{M_{y_{max}}} + \frac{M_z}{M_{z_{max}}} \leq 1$$

Permissible forces and torques					
Size		18	25	40	63
$F_{y_{max}}$	[N]	930	3080	7300	14050
$F_{z_{max}}$	[N]	930	3080	7300	14050
$M_{x_{max}}$	[Nm]	7	45	170	580
$M_{y_{max}}$	[Nm]	45	170	660	1820
$M_{z_{max}}$	[Nm]	45	170	660	1820

2nd moment of area

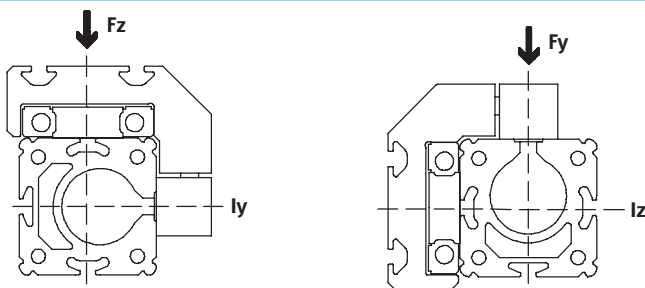

Size		18	25	40	63
l_y	[mm ⁴]	172.3x10 ³	551x10 ³	1908x10 ³	13677x10 ³
l_z	[mm ⁴]	73.7x10 ³	250x10 ³	875x10 ³	6987x10 ³

Spindle axes DGE-SP-KF, with recirculating ball bearing guide

Technical data

FESTO

Stroke reserve

L11 Internal mechanical stop
L1+ Overall length of axis
L17 Slide length

1 The working stroke is the effective usable work range. Please quote this in your order.

L12 The stroke reserve is a safety distance available on both sides of the axis in addition to the stroke.

Example:
Type DGE-25-500-SP
Working stroke = 500 mm
Stroke reserve = (2x 10 mm)
= 20 mm
Total stroke:
520 mm = 500 mm + 20 mm

for standard slide GK

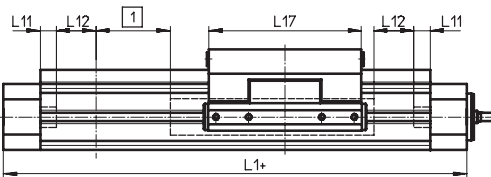

for extended slide GV

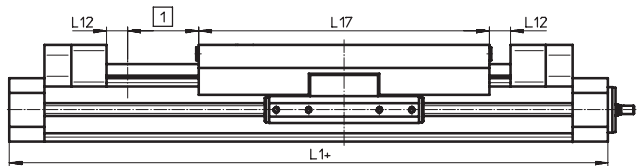

for protected version GA

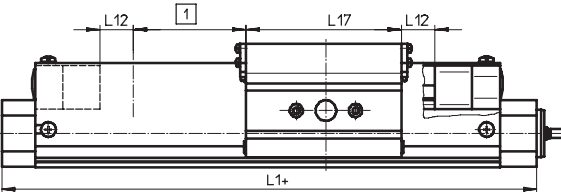

Stroke reserve L12 [mm] per end position

Size Variant	18	25	40	63
Standard slide GK	6.5	10	20	30
Extended slide GV	3.5	0	1	0
Protected version GA	-	0	1	-

Working stroke reduction with standard slide GK or extended slide GV and additional slide KL/KR

L17 = Slide/additional slide length
L18 = Distance between both slides
4 Additional slide

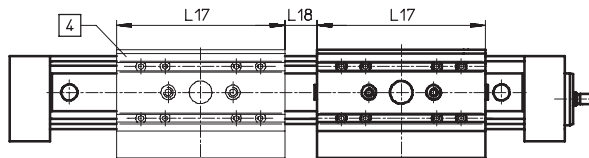

For a spindle axis with additional slide, the working stroke is reduced by the length of the additional slide and the distance between both slides.

Example:
Type DGE-25-500-SP-...-KF-GK-KL
Working stroke without additional slide = 500 mm
L18 = 20 mm
L17 = 105 mm
Working stroke with additional slide = 375 mm
(500 mm - 20 mm - 105 mm)

Working stroke reduction with standard slide GK with optional emergency buffer

2 Reduction of working stroke
5 Reduction of working stroke
3 Emergency buffer
4 Shock absorber retainer
L12 Stroke reserve

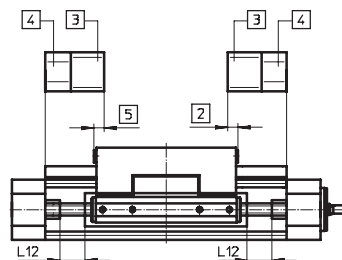

For a spindle axis with optional emergency buffer, the working stroke is reduced, as the stroke reserve is smaller than the overall dimensions of the emergency buffer and shock absorber retainer. The working stroke reduction varies depending on the size of the axis.

	18	25	40	63
2 [mm]	-5	20	33.5	55
5 [mm]	8	10	24.5	45

Spindle axes DGE-SP-KF, with recirculating ball bearing guide

Technical data

Maximum permissible support span l as a function of the force F

The axis may need to be supported with central supports in order to restrict deflection with long stroke lengths. The following diagrams serve to determine the maximum permissible support span l as a function of the force acting upon the axis F .

1 Force on the surface of the slide

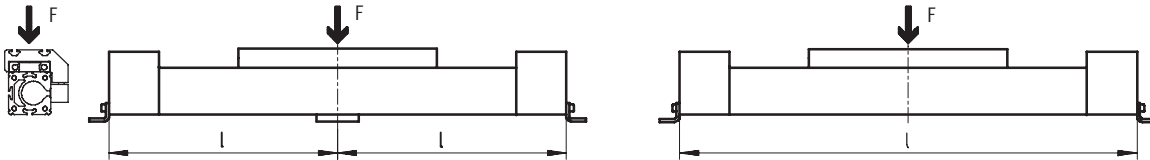

2 Force on the front of the slide

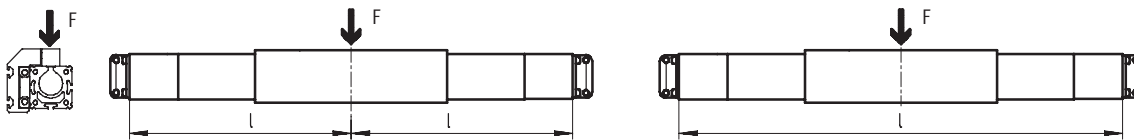

Maximum permissible support span l (without central support) as a function of the force F

DGE-18

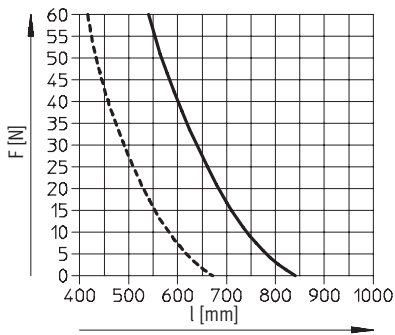

DGE-25

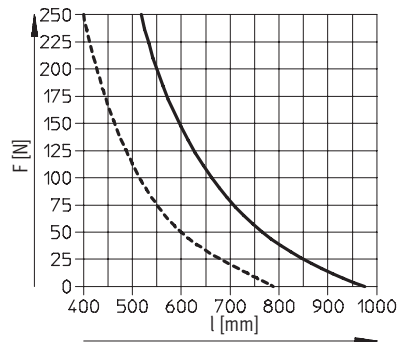

DGE-40

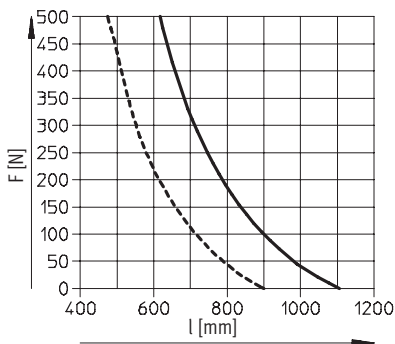

DGE-63

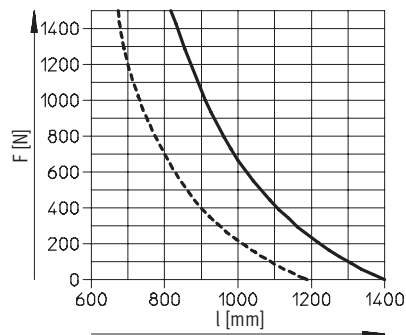

- 1
- - - 2

Spindle axes DGE-SP-KF, with recirculating ball bearing guide

Technical data

Maximum permissible speed v or drive rpm n as a function of the stroke l

DGE-18

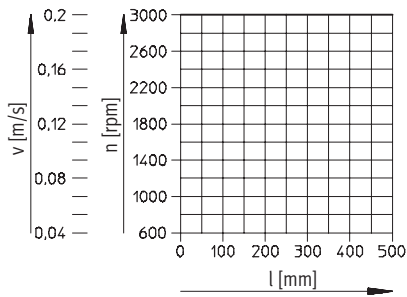

DGE-25

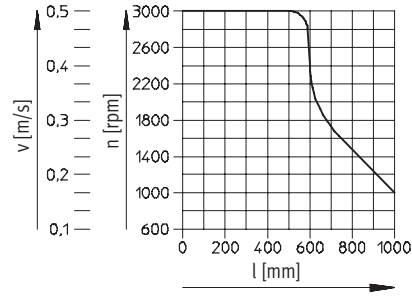

DGE-40

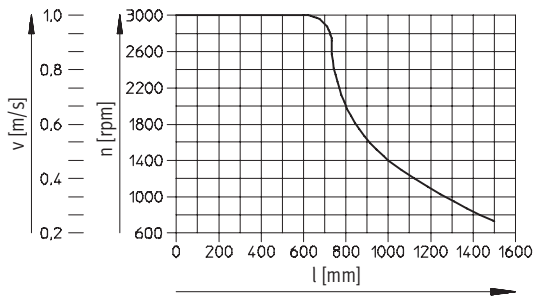

DGE-63

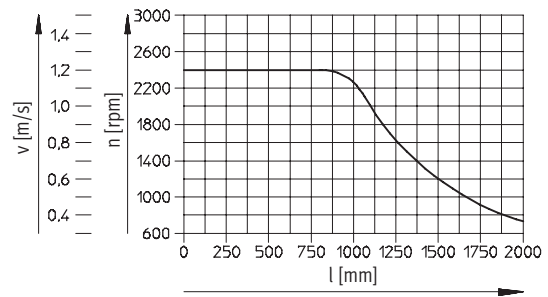

Spindle axes DGE-SP-KF, with recirculating ball bearing guide

Technical data

FESTO

Dimensions

Download CAD data → www.festo.com

Standard slide GK

Size 18

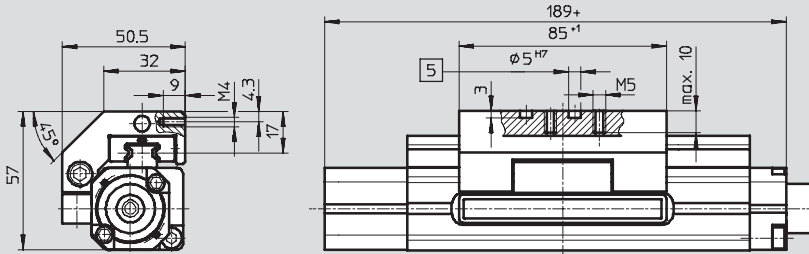

- 5 Hole for centring pin ZBS-5
- + = plus stroke length

Basic dimensions

→ 14

Stroke reserve

→ 28

Additional slide KL/KR

Size 18

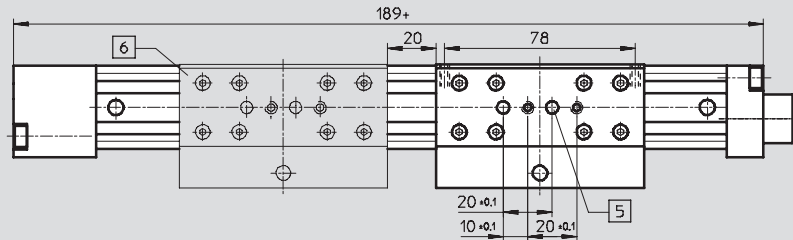

- 5 Hole for centring pin ZBS-5
- 6 Additional slide DGE-18-...-KL/KR
- + = plus stroke length

Reduction of working stroke

→ 28

Extended slide GV

Size 18

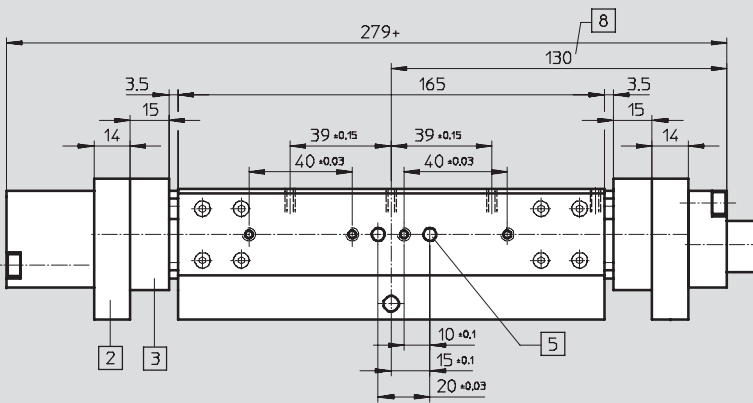

- 2 Shock absorber retainer KYP
- 3 Emergency buffer NPE
- 5 Hole for centring pin ZBS-5
- 8 Driver in end position of working stroke (stroke reserve up to mechanical stop still present)
- + = plus stroke length

Stroke reserve

→ 28

Profile

Size 18

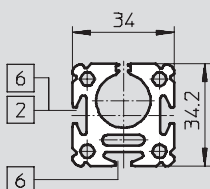

- 2 Sensor slot for proximity sensor
- 6 Mounting slot for slot nut NST

Spindle axes DGE-SP-KF, with recirculating ball bearing guide

Technical data

Dimensions Download CAD data → www.festo.com

Standard slide GK

Size 25 ... 63

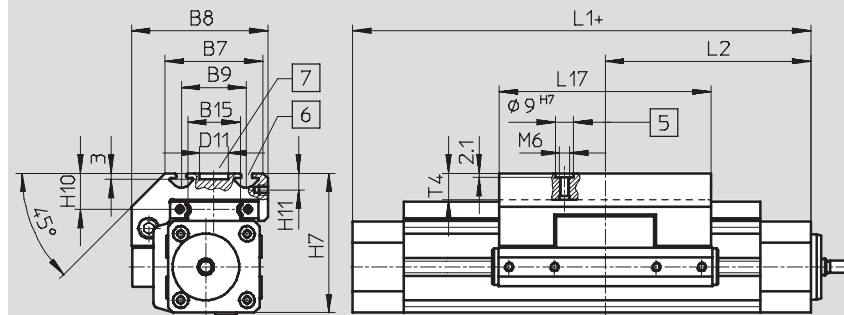

- 5 Hole for centring sleeve ZBH-9
- 6 Mounting slot for slot nut NSTL
- 7 Hole for central mounting SLZZ
- + = plus stroke length

Basic dimensions

→ 15

Stroke reserve

→ 28

Size 40/63

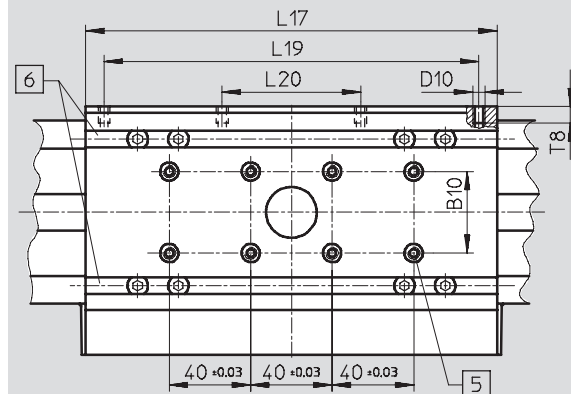

- 5 Hole for centring sleeve ZBH-9
- 6 Mounting slot for slot nut NSTL
- + = plus stroke length

Size 25 ... 63

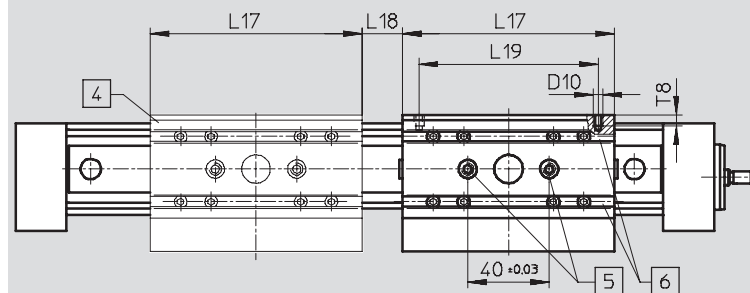

- 4 Additional slide
DGE-...-...-KL/KR
- 5 Hole for centring sleeve ZBH-9
- 6 Mounting slot for slot nut NSTL
- + = plus stroke length

Reduction of working stroke

→ 28

Spindle axes DGE-SP-KF, with recirculating ball bearing guide

Technical data

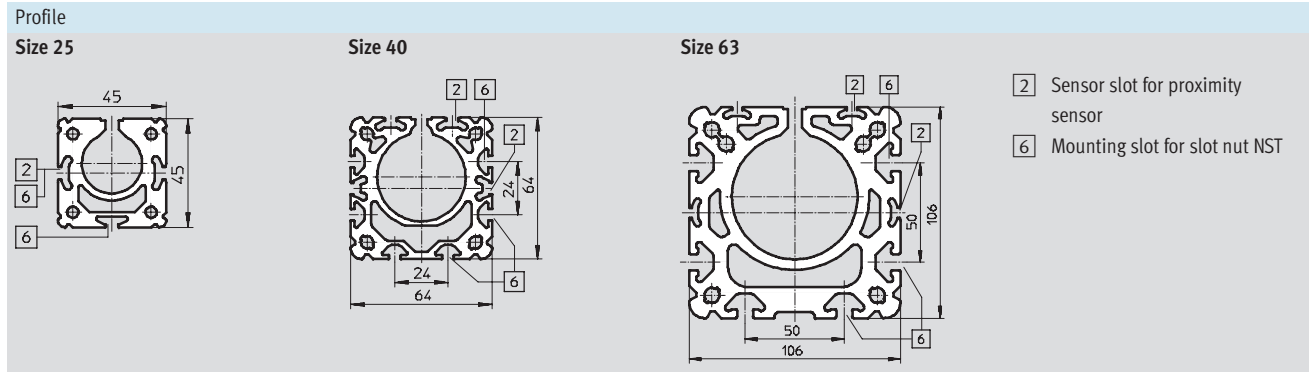

Size	B7	B8	B9 ±0.2	B10	B15	D10	D11 ∅ G7	H7	H10
25	48	67	32	–	23.5	M5	14	68.5	18.5
40	78.5	96.5	55	20	42	M5	25	90.5	20
63	121	142	90	40	71	M8	25	144.5	30

Size	H11	L1	L2	L17	L18 ¹⁾	L19 ±0.1	L20 ±0.1	T4 max.	T8
25	8.2	213	101.5	105	20	88	–	12.5	8.5
40	7	315	153	167	20	150	58	12.5	8.5
63	12.5	410	200	230	27	200	72	20.5	10.5

1) Recommended minimum distance for access to lubrication nipple

Spindle axes DGE-SP-KF, with recirculating ball bearing guide

Technical data

FESTO

Dimensions

Download CAD data → www.festo.com

Extended slide GV

Size 25 ... 63

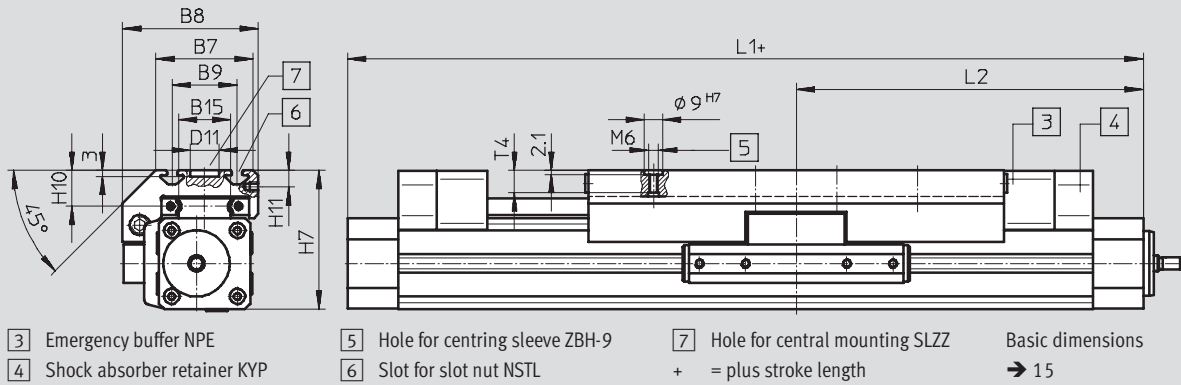

Size 25

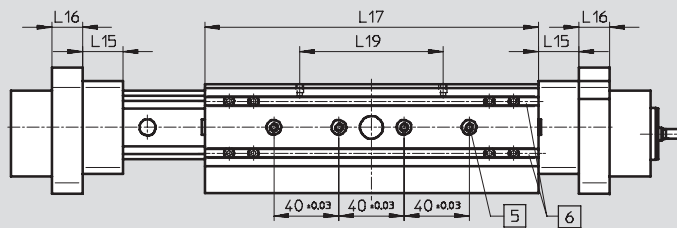

Size 40/63

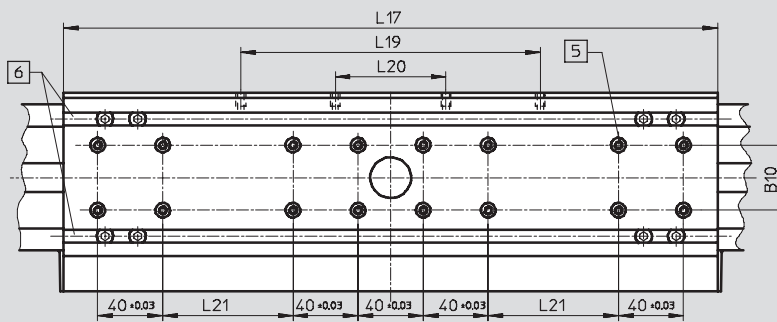

Spindle axes DGE-SP-KF, with recirculating ball bearing guide

Technical data

Size	B7	B8	B9 ±0.2	B10	B15	D10	D11 ∅ G7	H7	H10	H11
25	48	67	32	–	23.5	M5	14	68.5	18.5	8.2
40	78.5	96.5	55	20	42	M5	25	90.5	20	7
63	121	142	90	40	71	M8	25	144.5	30	12.5

Size	L1	L2	L15	L16	L17 ±0.2	L19 ±0.1	L20 ±0.1	L21 ±0.1	T4 max.	T8
25	343	171.5	25	19	205	88	–	–	12.5	8.5
40	545	271.5	40	32	337	150	58	40	12.5	8.5
63	760	380	60	44	480	200	72	120	20.5	10.5

Spindle axes DGE-SP-KF, with recirculating ball bearing guide

Technical data

FESTO

Dimensions

Download CAD data → www.festo.com

Protected version GA

Size 25

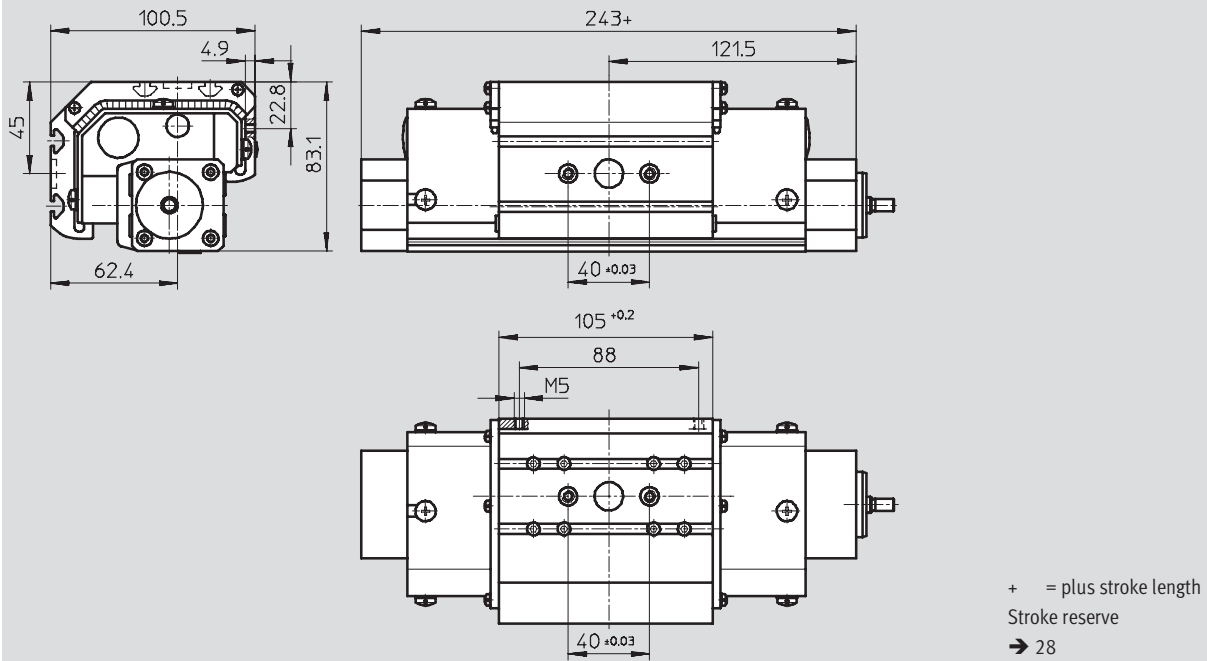

Size 40

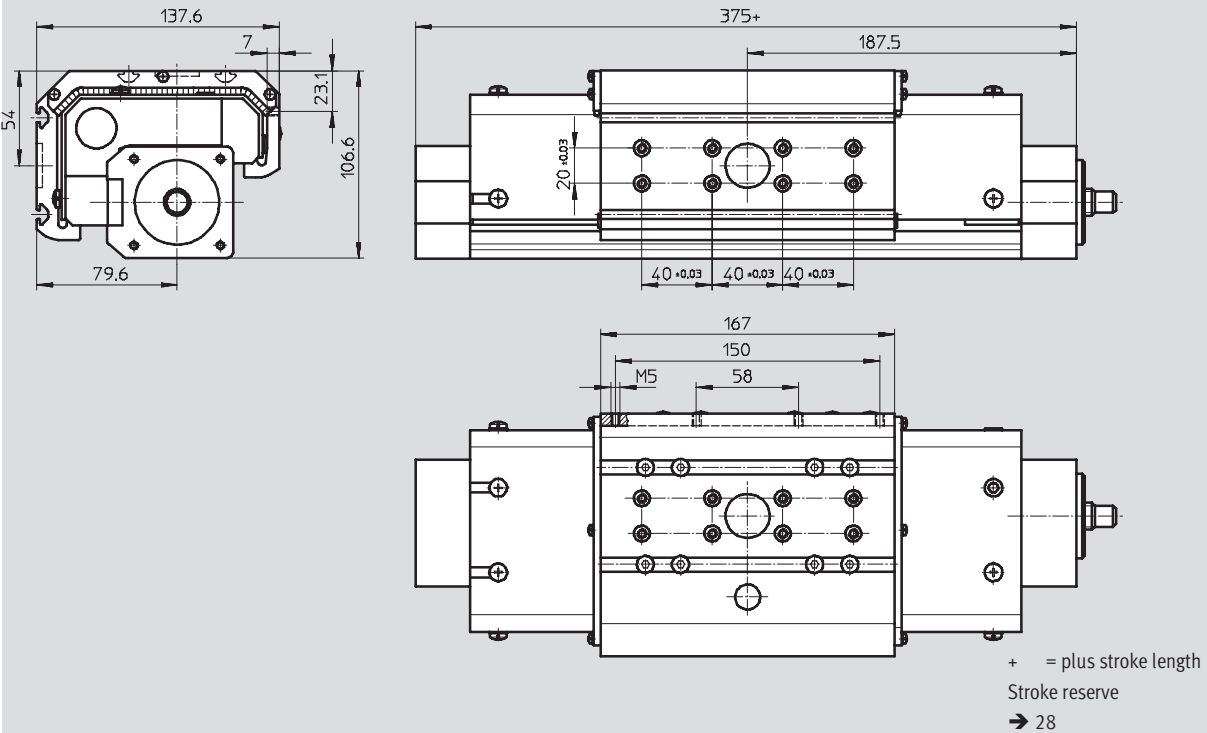

Spindle axes DGE-SP-KF, with recirculating ball bearing guide

Ordering data – Modular products

Order code

Mandatory data

Standard slide GK

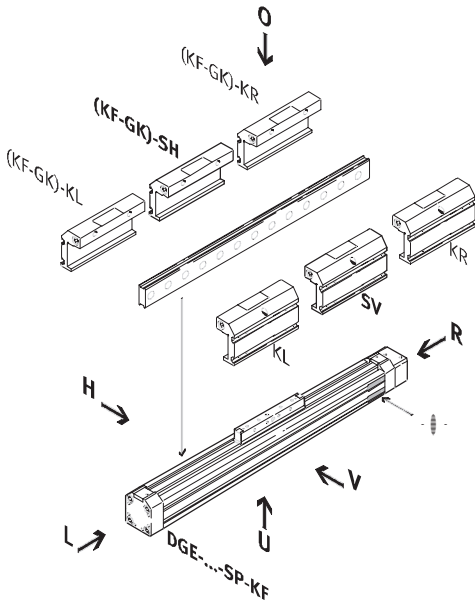

Extended slide GV

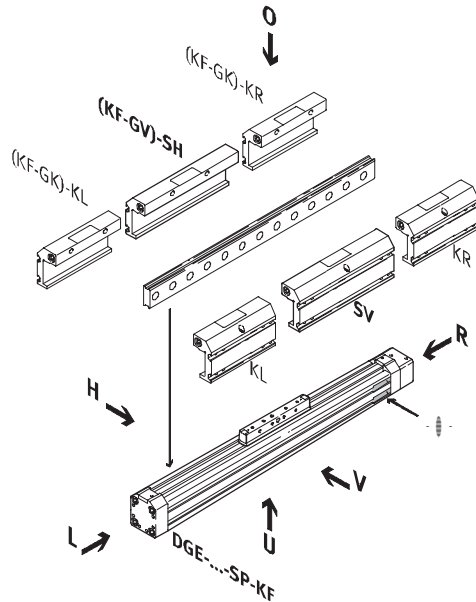

- KF Recirculating ball bearing guide
- KL Additional slide at left
- KR Additional slide at right
- SV Slide at front
- SH Slide at rear

-  - Note

The insertion point for the proximity sensor is located on the right-hand side of the spindle drive DGE-...-SP-KF

U = underneath
 O = top
 R = right
 L = left
 V = front
 H = rear

Protected version GA

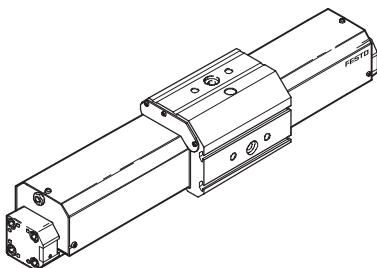

Spindle axes DGE-SP-KF, with recirculating ball bearing guide

Ordering data – Modular products

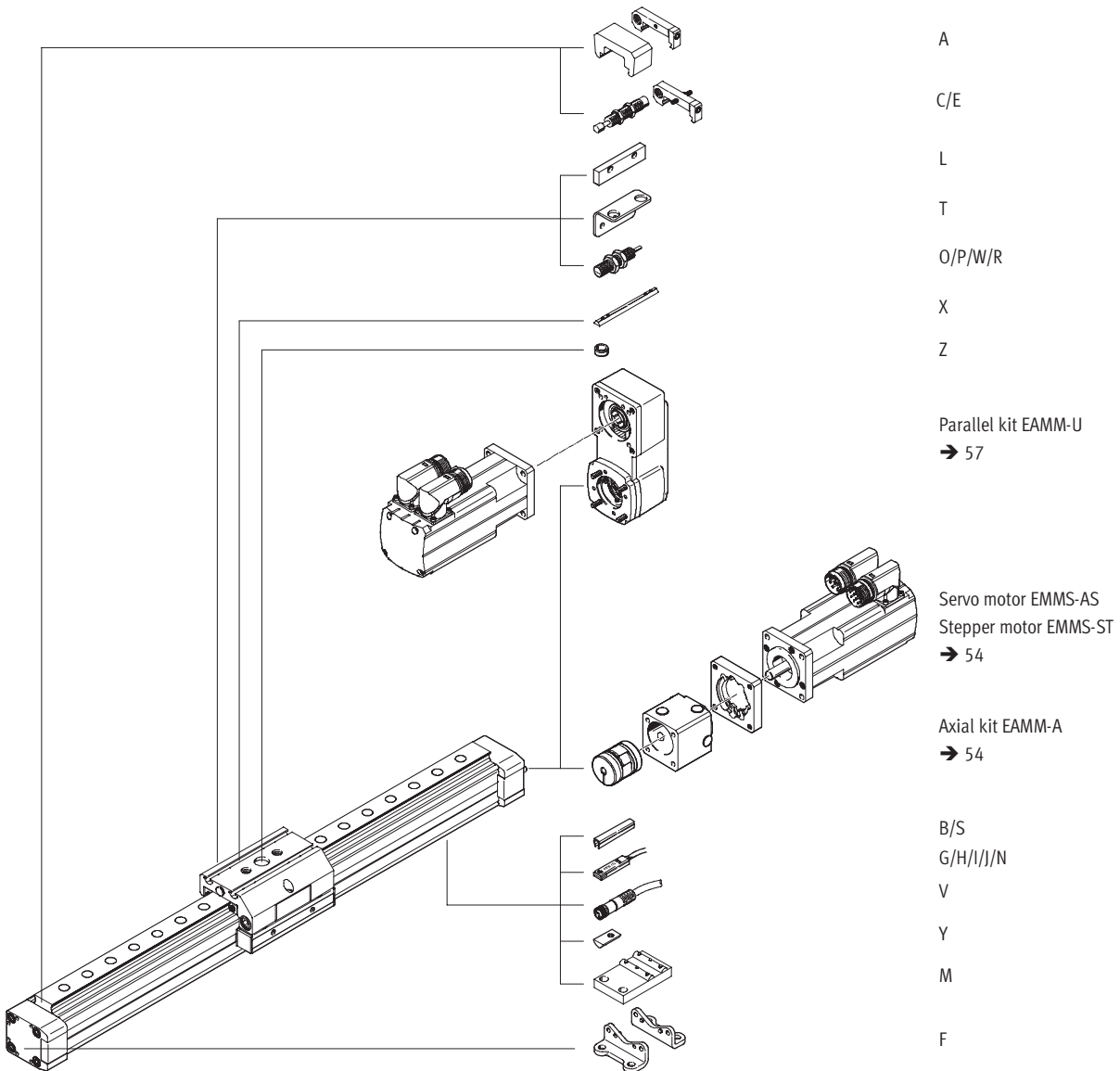

Spindle axes DGE-SP-KF, with recirculating ball bearing guide

Ordering data – Modular products

M Mandatory data →

Module No.	Design	Size	Stroke	Drive function
193 745 193 746 193 747 193 748	DGE	18 25 40 63	1 ... 2000	SP
Ordering example				
193 745	DGE	18	410	SP

Ordering table

Size	18	25	40	63	Condi- tions	Code	Enter code	
M Module No.	193 745	193 746	193 747	193 748				
Design	Electromechanical linear axis					DGE	DGE	
Size	18	25	40	63		-...		
Stroke [mm] Standard slide GK	100, 200, 300, 400, 500	100, 200, 300, 400, 500, 600, 700, 800, 900, 1000	200, 300, 400, 500, 600, 800, 1000, 1200, 1400, 1500	300, 400, 500, 600, 800, 1000, 1200, 1400, 1500, 1800, 2000		-...		
	-	1 ... 990	1 ... 1487	1 ... 1982				
	Extended slide GV	110, 210, 310, 410	170, 270, 370, 470, 570, 670, 770, 870	170, 270, 370, 570, 770, 970, 1170, 1270	150, 250, 450, 650, 850, 1050, 1150, 1450, 1650		-...	
	-	1 ... 860	1 ... 1257	1 ... 1632				
Protected version GA	-	170, 270, 370, 470, 570, 670, 770, 870, 970	140, 240, 340, 440, 540, 740, 940, 1140, 1340, 1440	-		-...		
	-	1 ... 960	1 ... 1427	-				
Drive function	Electromechanical drive with ball screw					-SP	-SP	

Transfer order code

	DGE	-		-		-	SP
--	------------	---	--	---	--	---	-----------

Spindle axes DGE-SP-KF, with recirculating ball bearing guide

Ordering data – Modular products

Options			
Guide	Slide	Slide attachment position	Additional slide
KF	GK GV GA	SV SH	KL KR
- KF	- GV	- SV	

Ordering table							
Size	18	25	40	63	Condi- tions	Code	Enter code
0 Guide	Recirculating ball bearing guide				1	-KF	-KF
Slide	Standard		Standard		2	-GK	
	Extended		Extended		3	-GV	
	Dust protection		Dust-proof version		3	-GA	
Slide attachment position	Slide at front					-SV	
	Slide at rear					-SH	
Additional slide	left (effective stroke reduction)	Standard slide at left (85 mm*)	(105 mm*)	(167 mm*)	(230 mm*)	4	-KL
	right (effective stroke reduction)	Standard slide at right (85 mm*)	(105 mm*)	(167 mm*)	(230 mm*)	4	-KR

* Plus working tolerance between slide and additional slide.

1 **KF** Only with slide GK, GV, GA.

2 **GK** Only with slide attachment position SV, SH.

Emergency buffer recommended → Accessory option "A".

3 **GV, GA** Only with slide attachment position SV, SH.

Emergency buffer included in delivery.

4 **KL, KR** Not with slide GA.

Emergency buffer recommended → Accessory option "A".

Transfer order code

- **KF** - - - - -

Spindle axes DGE-SP-KF, with recirculating ball bearing guide

Ordering data – Modular products

Options												
Accessories	Slot cover	Slot nut	Central support	Foot mounting	Emergency buffer and retainer	Shock absorber	Centring pins/sleeves	Proximity sensor	Plug socket	Sensor bracket	Switching lug	Inductive sensor
ZUB	...S ...B	...Y ...X	...M	...F	...A	...C ...E	...Z	...G ...H ...I ...J ...N	...V	...T	L	...O ...P ...W ...R
ZUB	- 2S	10Y		F				2G				

Ordering table										
Size		18	25	40	63	Conditions	Code	ZUB-	Enter code	
↓	Accessories	Supplied separately						ZUB-		ZUB-
0	Slot cover	Sensor slot	1 ... 10					...S		
		Mounting slot	-	-	1 ... 10			...B		
	Slot nut	for mounting slot	1 ... 10					...Y		
		for slide	-	1 ... 10				...X		
	Central support	1 ... 10					...M			
	Foot mounting (kit)	1 ... 10					...F			
	Emergency buffer and retainer for KF	1 ... 2					[9]	...A		
		(effective stroke reduction with emergency buffer at both ends)	(10 mm)	(30 mm)	(60 mm)	(100 mm)				
		Shock absorber and retainer for KF-GK, KF-GV	1 ... 2				[10]	...C		
		for KF-GA	-	1 ... 2		-	[11]	...E		
	Centring pins/sleeves (pack of 10)	10, 20, 30, 40, 50, 60, 70, 80, 90					...Z			
	Proximity sensor	with cable, 2.5 m	1 ... 10					...G		
		with plug	1 ... 10					...H		
		contactless with cable, 2.5 m	1 ... 10					...I		
		contactless, plug	1 ... 10					...J		
		NC contact with cable, 2.5 m	1 ... 10					...N		
	Cable with socket, 2.5 m	1 ... 10					...V			
	Sensor bracket for inductive sensors	1 ... 5					[10]	...T		
	Switching lug	1					[10]	L		
	Inductive sensor	NO contact, cable	1 ... 5					[10]	...O	
		NC contact, cable	1 ... 5					[10]	...P	
		NO contact, plug	1 ... 5					[10]	...W	
		NC contact, plug	1 ... 5					[10]	...R	

[9] A Only with slide GK.
Mounted as standard for slide GV, GA

[11] E Only with slide GA.

[10] C, T, L, O, P, W, R.
Not with slide GA.

Transfer order code

ZUB -

Spindle axes DGE-SP-HD, with heavy-duty guide

Peripherals overview

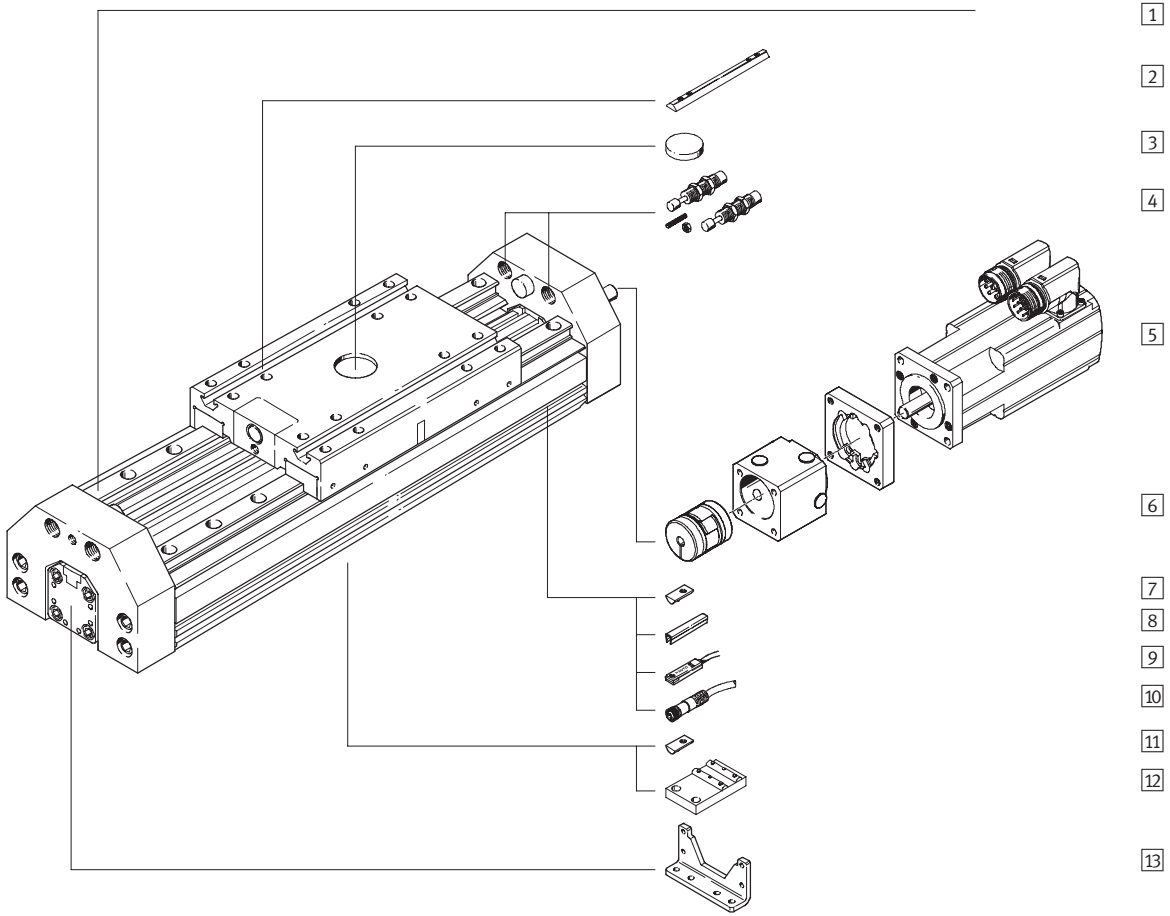
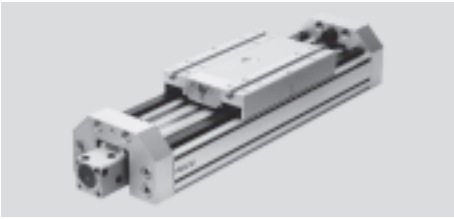

Spindle axes DGE-SP-HD, with heavy-duty guide

Peripherals overview

Variants and accessories		
Type	Brief description	→ Page/Internet
1 Spindle axis DGE-SP-HD	Electromechanical axis with heavy-duty guide	44
2 Slot nut for slide X	For mounting loads and attachments on the slide	68
3 Centring disc Q	For centring loads and attachments on the slide	68
4 Shock absorber kits D	For avoiding damage at the end stop in the event of malfunction	65
5 Axial kit EAMM-A	For axial motor attachment (consisting of: coupling housing, clamping component, motor flange)	54
6 Motor EMMS	Motors specially matched to the axis, with or without gearing, with or without brake	54
7 Slot nut for mounting slot Y	For mounting attachments	68
8 Slot cover B/S	For protecting against the ingress of dirt	68
9 Proximity sensor G/H/I/J/N	For use as a signal generator and safety monitoring	69
10 Cable with socket V	For proximity sensors	69
11 Slot nut for HD underneath U	For mounting attachments	68
12 Central support M	For mounting the axis	62
13 Foot mounting F	For mounting the axis	62

Spindle axes DGE-SP-HD, with heavy-duty guide

Type code

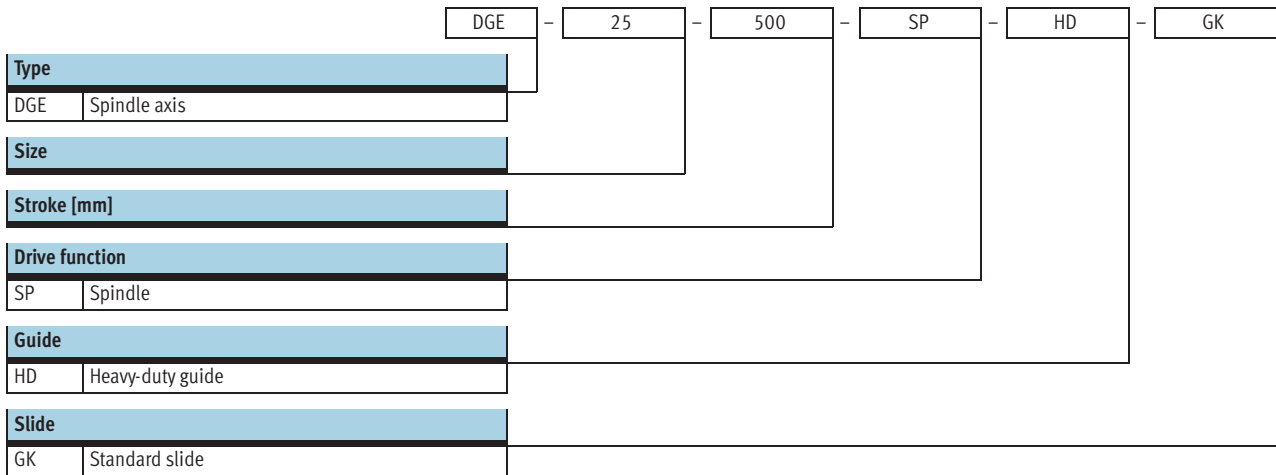

Spindle axes DGE-SP-HD, with heavy-duty guide

Type code

		+ ZUB	-			F		Q	2H	2V
Accessories										
ZUB	Accessories supplied loose									
Slot cover										
...S	Sensor slot									
...B	Mounting slot									
Slot nut										
...Y	For mounting slot									
...X	For slide									
...U	For HD underneath									
Central support										
...M	Central support									
Foot mounting										
...F	Foot mounting									
Shock absorber										
...D	Kit for HD									
Central mounting										
...Q	Central mounting									
Proximity sensor										
...G	With cable, 2.5 m									
...H	With plug									
...I	Contactless with cable, 2.5 m									
...J	Contactless, plug									
...N	NC contact with cable, 2.5 m									
Cable with socket										
...V	2.5 m									

Spindle axes DGE-SP-HD, with heavy-duty guide

Technical data

Function

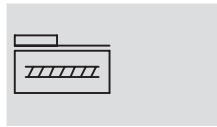

- - Size
18 ... 40
- - Stroke length
1 ... 1500 mm

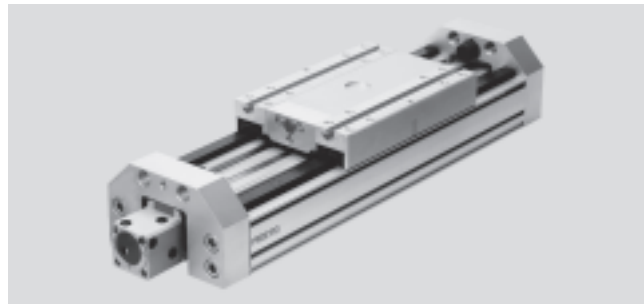

General technical data					
Size		18-HD18	25-HD25	25-HD40	40-HD40
Constructional design		Electromechanical axis with heavy-duty guide			
Guide		Recirculating ball bearing guide			
Mounting position		Any			
Max. working stroke	[mm]	100 ... 400	1 ... 900	1 ... 900	1 ... 1500
Max. working load	[kg]	6	25	25	50
Max. feed force F_x	[N]	140	250	250	600
Max. driving torque	[Nm]	0.1	0.45	0.45	2.1
No-load torque ¹⁾	[Nm]	0.05	0.2	0.2	0.43
Max. radial force ²⁾	[N]	40	75	250	800
Max. speed	[m/s]	0.2	0.5	0.5	1
Max. acceleration	[m/s ²]	6			
Repetition accuracy	[mm]	±0.02			

- 1) Measured at a speed of 0.2 m/s
2) On drive shaft

Operating and environmental conditions					
Size		18-HD18	25-HD25	25-HD40	40-HD40
Ambient temperature	[°C]	0 ... +40			
Protection class		IP40			

Weights [kg]					
Size		18-HD18	25-HD25	25-HD40	40-HD40
Basic weight with 0 mm stroke ¹⁾		4.31	7.04	16.13	19.02
Additional weight per 100 mm stroke		0.32	1.6	2.19	2.62

- 1) Including coupling housing and slide

Mass moment of inertia					
Size		18-HD18	25-HD25	25-HD40	40-HD40
J_0	[kg cm ²]	0.013	0.086	0.375	0.698
J_H per metre stroke	[kg cm ² /m]	0.031	0.121	0.121	1
J_L per kg working load	[kg cm ² /kg]	0.005	0.025	0.025	0.101

The mass moment of inertia J_A of the entire axis is calculated as follows:

$$J_A = J_0 + J_H \times \text{working stroke [m]} + J_L \times m_{\text{working load [kg]}}$$

Spindle axes DGE-SP-HD, with heavy-duty guide

Technical data

Spindle		18-HD18	25-HD25	25-HD40	40-HD40
Size					
Diameter	[mm]	8	12	12	20
Pitch	[mm/rev.]	4	10	10	20

Materials

Sectional view

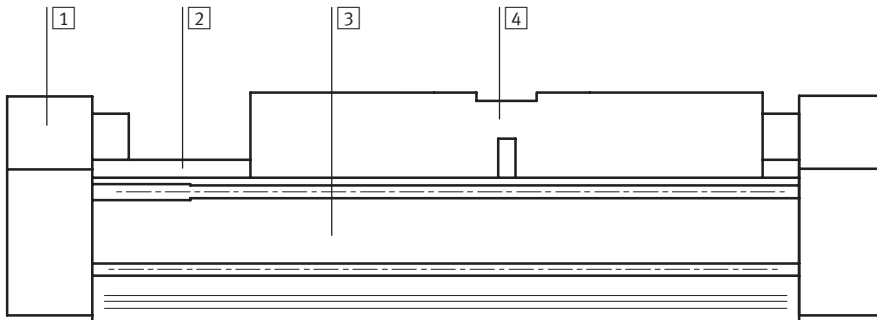

Axis		
1	End cap	Anodised aluminium
2	Guide	Rolled steel
3	Profile	Anodised aluminium
4	Slide	Anodised aluminium

Spindle axes DGE-SP-HD, with heavy-duty guide

Technical data

Characteristic load values

The indicated forces and torques refer to the centre of the heavy-duty guide.

They must not be exceeded in the dynamic range. Special attention must be paid to the cushioning phase.

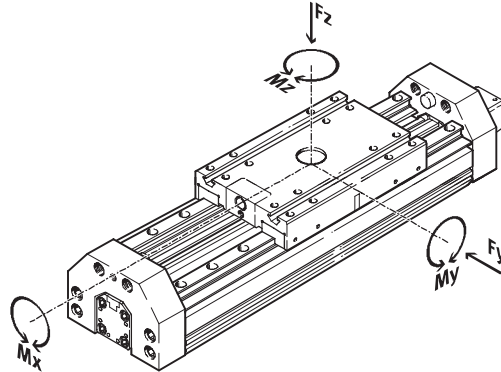

If the drive is subjected to more than two of the indicated forces and torques simultaneously, the following equations must be satisfied in addition to the indicated maximum loads:

$$\frac{F_y}{F_{y_{max}}} + \frac{F_z}{F_{z_{max}}} + \frac{M_x}{M_{x_{max}}} + \frac{M_y}{M_{y_{max}}} + \frac{M_z}{M_{z_{max}}} \leq 1$$

Permissible forces and torques					
Size		18-HD18	25-HD25	25-HD40	40-HD40
F _y _{max.}	[N]	1820	5400	5400	5400
F _z _{max.}	[N]	1820	5600	5600	5600
M _x _{max.}	[Nm]	70	260	375	375
M _y _{max.}	[Nm]	115	415	560	560
M _z _{max.}	[Nm]	112	400	540	540

-  - Note
 Sizing software
 PositioningDrives
 → www.festo.com

Spindle axes DGE-SP-HD, with heavy-duty guide

Technical data

Maximum permissible support span l as a function of the force F

The drive may need to be supported in order to restrict deflection with long stroke lengths. The following diagrams serve to determine the

maximum permissible support span l as a function of the force acting upon the axis F .

Force on the surface of the slide

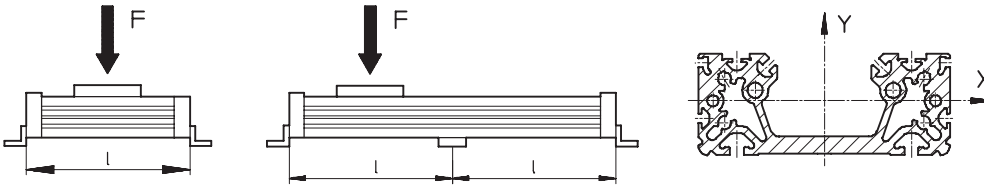

Maximum permissible support span l (without central support) as a function of the force F

Deflection around the X axis

Deflection around the Y axis

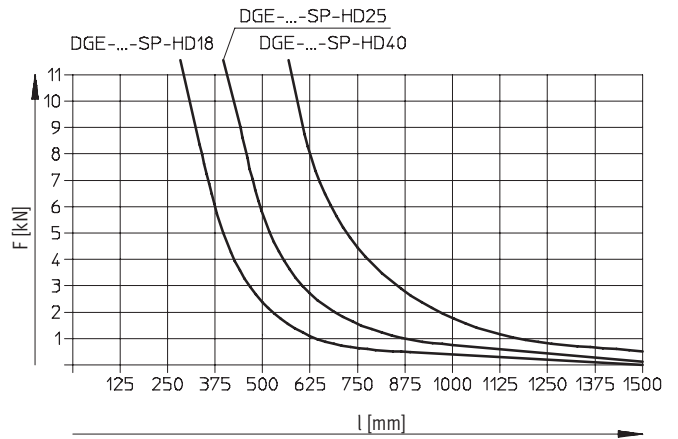
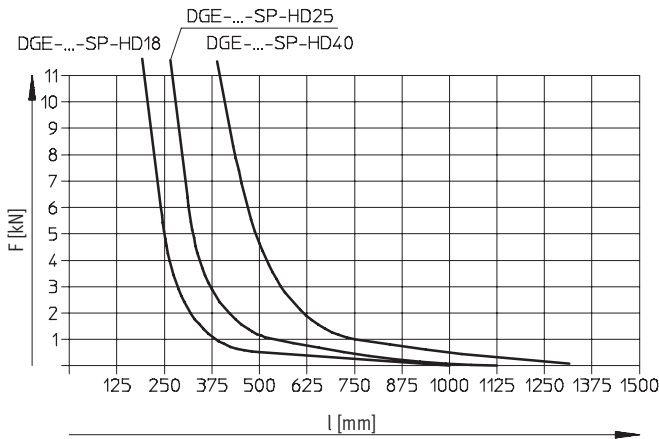

Spindle axes DGE-SP-HD, with heavy-duty guide

Technical data

FESTO

Dimensions

Download CAD data → www.festo.com

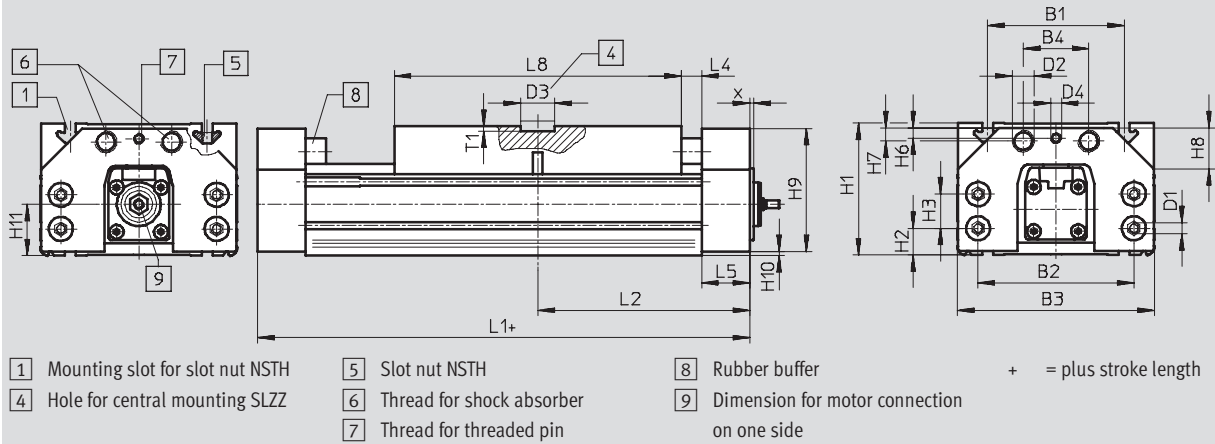

Profile

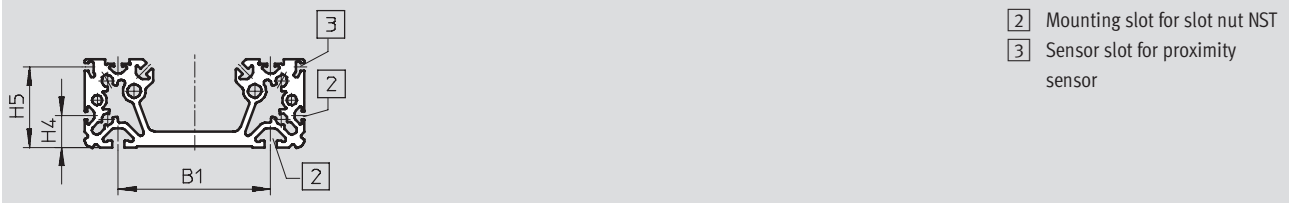

Size	B1	B2 ±0,2	B3	B4	D1	D2	D3 ∅ G7	D4	D5	H1	H2	H3	H4
18-HD18	80±0,3	85	116	40	M5	M12x1	25	M6	M5	70	12.8	19.5±0,1	14
25-HD-25	100±0,3	114	144	48	M8	M16x1	25	M8	G1/8	93.5	18.5	25±0,2	21
25-HD40	140±0,35	156	185	54	M8	M22x1.5	25	M8	G1/8	124.5	21	48±0,2	35
40-HD40	140±0,35	156	185	54	M8	M22x1.5	25	M8	G1/4	124.5	21	48±0,2	35

Size	H5	H6	H7	H8	H9	H10	H11	L1	L2	L4	L5	L8	T1	X
18-HD18	42.3	5.9	8.7	20x45°	68	0.8	30.3	240	120	15	25	160	3.5	49
25-HD25	52.8	9	9.8	30x45°	90	2	37	310	155	15	35	210	3.5	3
25-HD40	82.8	5.5	15.5	35x45°	120	2	63	354	177	15	32	260	4	-
40-HD40	82.8	5.5	15.5	35x45°	120	2	52.5	354	177	15	32	260	4	-7

Spindle axes DGE-SP-HD, with heavy-duty guide

Ordering data – Modular products

Order code

Mandatory data

Heavy-duty guide HD

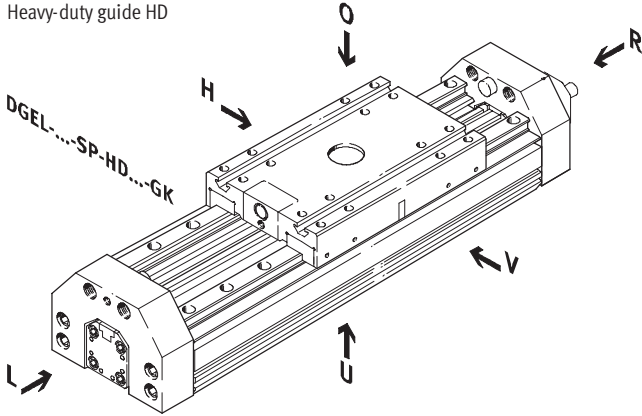

-  - Note

The insertion point for the proximity sensor is located on the right-hand side of the heavy-duty guide

- U = underneath
- O = top
- R = right
- L = left
- V = front
- H = rear

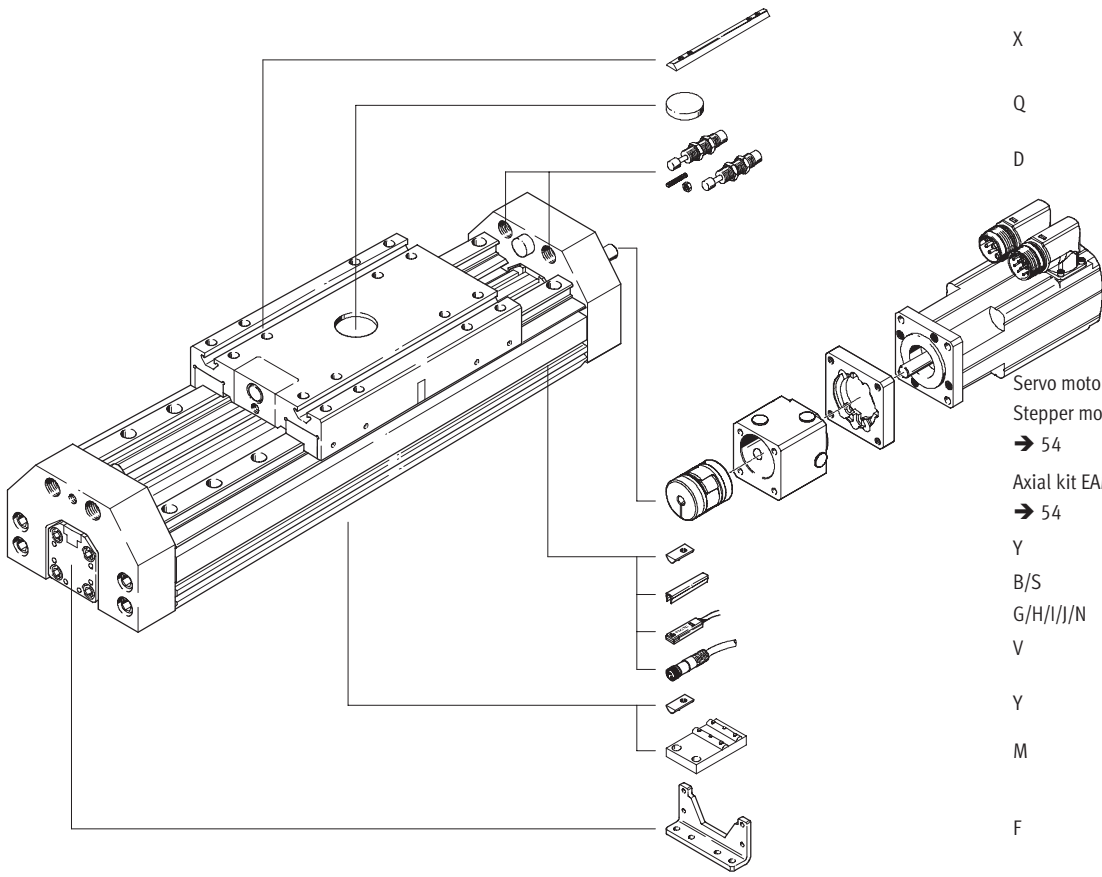

- X
- Q
- D
- Servo motor EMMS-AS
- Stepper motor EMMS-ST
- 54
- Axial kit EAMM-A
- 54
- Y
- B/S
- G/H/I/J/N
- V
- Y
- M
- F

Spindle axes DGE-SP-HD, with heavy-duty guide

Ordering data – Modular products



M Mandatory data					O Options →	
Module No.	Design	Size	Stroke	Drive function	Guide	Slide
193 745 193 746 193 747	DGE	18 25 40	1 ... 1 500	SP	HD18 HD25 HD40	GK
Ordering example						
193 747	DGE	- 40	- 800	- SP	- HD40	- GK

Ordering table						
Size	18	25	40	Condi- tions	Code	Enter code
M Module No.	193 745	193 746	193 747			
Design	Electromechanical linear axis				DGE	DGE
Size	18	25	40		-...	
Stroke [mm]	100, 200, 300, 400	100, 200, 300, 400, 500, 600, 700, 800, 900	200, 300, 400, 500, 600, 800, 1000, 1200, 1400, 1500		-...	
	-	1 ... 890	1 ... 1487			
Drive function	Electromechanical drive with ball screw				-SP	-SP
O Guide	Heavy-duty guide HD18	-	-		-HD18	-HD...
	-	Heavy-duty guide HD25	-		-HD25	
	-	Heavy-duty guide HD40	Heavy-duty guide HD40		-HD40	
Slide	Standard			1	-GK	-GK

1 GK Emergency buffer recommended → Accessory option "A".

Transfer order code

	DGE	-		-		-	SP	-	HD...	-	GK
--	-----	---	--	---	--	---	----	---	-------	---	----

Spindle axes DGE-SP-HD, with heavy-duty guide

Ordering data – Modular products



Options								
Accessories	Slot cover	Slot nut	Central support	Foot mounting	Shock absorber	Central mounting	Proximity sensor	Plug socket
ZUB	...S ...B	...Y ...X ...U	...M	...F	...D	...Q	...G ...H ...I ...J ...N	...V
ZUB	2SB	10Y2X	M	F		Q	2J	2V

Ordering table							
Size		18	25	40	Condi- tions	Code	Enter code
↓	Accessories	Supplied separately				ZUB-	ZUB-
0	Slot cover	Sensor slot	1 ... 10			...S	
		Mounting slot	1 ... 10			...B	
	Slot nut	for mounting slot	1 ... 10			...Y	
		for slide	1 ... 10			...X	
		for HD underneath	1 ... 10			...U	
	Central support	1 ... 10				...M	
	Foot mounting (kit)	1 ... 10				...F	
	Shock absorber	Kit for HD	1 ... 2			...D	
	Central mounting	1 ... 10				...Q	
	Proximity sensor	with cable, 2.5 m	1 ... 10			...G	
		with plug	1 ... 10			...H	
		contactless with cable, 2.5 m	1 ... 10			...I	
		contactless, plug	1 ... 10			...J	
		NC contact with cable, 2.5 m	1 ... 10			...N	
	Cable with socket, 2.5 m	1 ... 10				...V	



Transfer order code

ZUB -

Spindle axes DGE

Accessories

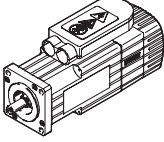
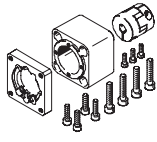

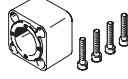
FESTO

Permissible axis/motor combinations with axial kit – Without gear unit				
Motor	Axial kit	Axial kit consisting of:		
		Motor flange	Coupling	Coupling housing
				
Type	Part No. Type	Part No. Type	Part No. Type	Part No. Type
DGE-18				
with servo motor				
EMMS-AS-40-...	550 961 EAMM-A-E20-40A	552 163 EAMF-A-28B-40A	540 751 EAMC-15-22-5-6	170 374 EAMK-A-E20-28B
EMMS-AS-55-...	550 963 EAMM-A-E20-55A	529 946 EAMF-A-28A/B-55A	529 953 EAMC-15-22-5-9	170 374 EAMK-A-E20-28B
with stepper motor				
EMMS-ST-42-...	550 962 EAMM-A-E20-42A	552 164 EAMF-A-28B-42A	530 085 EAMC-15-22-5-5	170 374 EAMK-A-E20-28B
with intelligent motor unit				
MTR-DCI-32S-...	556 991 EAMM-A-E20-32B	–	533 707 EAMC-15-20-5-6	533 703 EAMK-A-E20-32B
DGE-25				
with servo motor				
EMMS-AS-40-...	550 964 EAMM-A-E32-40A	550 985 EAMF-A-44A/B-40A	123 040 EAMC-30-35-6-6	124 631 EAMK-A-E32-44A
EMMS-AS-55-...	550 965 EAMM-A-E32-55A	529 942 EAMF-A-44A/B-55A	530 941 EAMC-30-35-6-9	124 631 EAMK-A-E32-44A
with stepper motor				
EMMS-ST-57-...	550 966 EAMM-A-E32-57A	530 081 EAMF-A-44A/B-57A	530 087 EAMC-30-35-6-6.35	124 631 EAMK-A-E32-44A
with intelligent motor unit				
MTR-DCI-42S-...-G07	556 992 EAMM-A-E32-42B	–	533 708 EAMC-30-32-6-8	533 704 EAMK-A-E32-42B
MTR-DCI-42S-...-G14	556 993 EAMM-A-E32-42C	–	533 708 EAMC-30-32-6-8	538 578 EAMK-A-E32-42C

Spindle axes DGE

Accessories

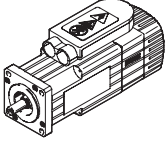
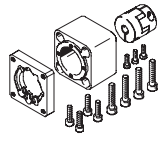
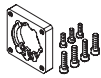

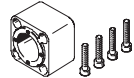
FESTO

Permissible axis/motor combinations with axial kit – Without gear unit				
Motor	Axial kit	Axial kit consisting of:		
		Motor flange	Coupling	Coupling housing
				
Type	Part No. Type	Part No. Type	Part No. Type	Part No. Type
DGE-40				
With servo motor				
EMMS-AS-55-...	550 969 EAMM-A-E48-55A	529 942 EAMF-A-44A/B-55A	550 996 EAMC-30-35-9-12	124 632 EAMK-A-E48-44A
EMMS-AS-70-...	550 971 EAMM-A-E48-44A-70A	529 943 EAMF-A-44A/B-70A	123 051 EAMC-30-35-11-12	124 632 EAMK-A-E48-44A
EMMS-AS-100-...	550 973 EAMM-A-E48-100A	529 947 EAMF-A-64A/C-100A	529 952 EAMC-40-66-12-19	529 940 EAMK-A-E48-64A
With stepper motor				
EMMS-ST-57-...	550 970 EAMM-A-E48-57A	530 081 EAMF-A-44A/B-57A	550 995 EAMC-30-35-6.35-12	124 632 EAMK-A-E48-44A
EMMS-ST-87-...	550 972 EAMM-A-E48-87A	533 140 EAMF-A-64A/B-87A	525 864 EAMC-40-66-11-12	529 940 EAMK-A-E48-64A
With intelligent motor unit				
MTR-DCI-52S-...-G07	556 994 EAMM-A-E48-52B	–	533 709 EAMC-42-50-12-12	533 705 EAMK-A-E48-52B
MTR-DCI-52S-...-G14	556 995 EAMM-A-E48-52C	–	533 709 EAMC-42-50-12-12	538 579 EAMK-A-E48-52C
DGE-63				
With servo motor				
EMMS-AS-70-...	550 975 EAMM-A-E72-70A	529 945 EAMF-A-64A/B-70A	550 999 EAMC-40-66-11-20	529 941 EAMK-A-E72-64A
EMMS-AS-100-...	550 978 EAMM-A-E72-100A	529 947 EAMF-A-64A/C-100A	123 847 EAMC-40-66-19-20	529 941 EAMK-A-E72-64A
With stepper motor				
EMMS-ST-87-...	550 977 EAMM-A-E72-87A	533 140 EAMF-A-64A/B-87A	550 999 EAMC-40-66-11-20	529 941 EAMK-A-E72-64A
With intelligent motor unit				
MTR-DCI-62S-...	556 996 EAMM-A-E72-62B	–	533 710 EAMC-42-50-14-20	533 706 EAMK-A-E72-62B

Spindle axes DGE

Accessories

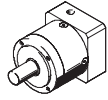
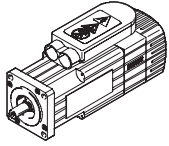
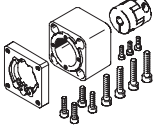
FESTO

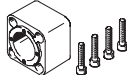
Permissible axis/motor combinations with axial kit – With gear unit					
Gear unit	Motor	Axial kit	Axial kit consisting of:		
			Motor flange	Coupling	Coupling housing
					
Type	Type	Part No. Type	Part No. Type	Part No. Type	Part No. Type
DGE-40					
with servo motor					
EMGA-40-P-G...-SAS-40	EMMS-AS-40-...	550 968 EAMM-A-E48-40G	550 986 EAMF-A-44A/B-40G	552 640 EAMC-30-35-10-12	124 632 EAMK-A-E48-44A
DGE-63					
with servo motor					
EMGA-60-P-G...-SAS-70	EMMS-AS-70-S-...	550 974 EAMM-A-E72-60G	550 987 EAMF-A-64A/B-60G	550 999 EAMC-40-66-11-20	529 941 EAMK-A-E72-64A
EMGA-80-P-G...-SAS-70	EMMS-AS-70-M-...	550 976 EAMM-A-E72-80G	533 139 EAMF-A-64A/C-80G	123 849 EAMC-40-66-20-20	529 941 EAMK-A-E72-64A
with stepper motor					
EMGA-80-P-G...-SST-87	EMMS-ST-87-...	550 976 EAMM-A-E72-80G	533 139 EAMF-A-64A/C-80G	123 849 EAMC-40-66-20-20	529 941 EAMK-A-E72-64A

Spindle axes DGE

Accessories

FESTO

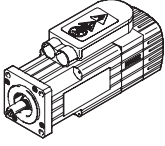
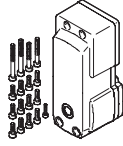
Permissible axis/motor combinations with parallel kit – Without gear unit		
Motor	Parallel kit	
		
Type	Part No.	Type
DGE-25		
with servo motor		
EMMS-AS-55-...	543 230	EAMM-U-E32-55A
with intelligent motor unit		
MTR-DCI-42S-...-G07	543 228	EAMM-U-E32-42B
MTR-DCI-42S-...-G14	543 229	EAMM-U-E32-42C
DGE-40		
with servo motor		
EMMS-AS-70-...	543 234	EAMM-U-E48-70A
with intelligent motor unit		
MTR-DCI-52S-...-G07	543 232	EAMM-U-E48-52B
MTR-DCI-52S-...-G14	543 233	EAMM-U-E48-52C

Spindle axes DGE

Accessories

FESTO

Axial kit EAMM-A-...

Material:

Coupling housing, coupling hubs:

Aluminium

Clamping component:

Steel, corrosion resistant

Motor flange: Wrought aluminium alloy

Screws: Galvanised steel

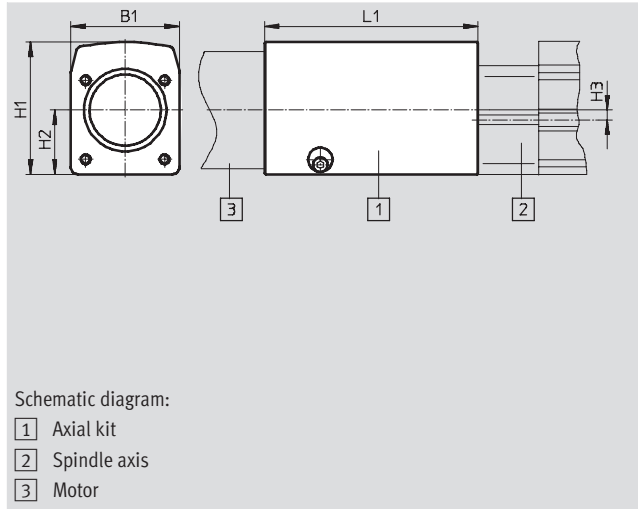

General technical data		E20-				E32-				
		32B	40A	42A	55A	40A	42B	42C	55A	57A
Transferable torque	[Nm]	1.5	1			7.5	7		7.5	
Mass moment of inertia	[kgmm ²]	0.23	0.13			6.1	5.87		6.1	
Max. speed	[1/min]	10000	12000			8000				
Mounting position		Any								

EAMM-A-...		E48-							
		52B	52C	55A	57A	44A-70A	87A	100A	40G
Transferable torque	[Nm]	17		8.3	7.5	8.9	17		8.6
Mass moment of inertia	[kgmm ²]	35.5		6.1			42.3		6.1
Max. speed	[1/min]	6000		8000			6500		8000
Mounting position		Any							

EAMM-A-...		E72-					
		62B	70A	87A	100A	60G	80G
Transferable torque	[Nm]	17					
Mass moment of inertia	[kgmm ²]	35.5	42.3				
Max. speed	[1/min]	6000	6500				
Mounting position		Any					

Operating and environmental conditions		
Ambient temperature	[°C]	0 ... 50
Storage temperature	[°C]	-25 ... +60
Protection class ¹⁾		IP40
Relative air humidity	[%]	0 ... 95

1) Only with combined attachment of motor and axis

Spindle axes DGE

Accessories

FESTO

Dimensions and ordering data							
Type	B1	H1	H2	H3	L1	Weight [g]	Part No. Type
EAMM-A-E20-32B	33.6	41	21.6	0	27	80	556 991 EAMM-A-E20-32B
EAMM-A-E20-40A	33.5	31.5	15.75		27.4	78	550 961 EAMM-A-E20-40A
EAMM-A-E20-42A					35.7	91	550 962 EAMM-A-E20-42A
EAMM-A-E20-55A					29.5	134	550 963 EAMM-A-E20-55A
EAMM-A-E32-40A	45	45	26.5	4	52.5	243	550 964 EAMM-A-E32-40A
EAMM-A-E32-42B	44.8	54.4	26.4		88	50	556 992 EAMM-A-E32-42B
EAMM-A-E32-42C					101	50	556 993 EAMM-A-E32-42C
EAMM-A-E32-55A	45	45	26.5		53.7	271	550 965 EAMM-A-E32-55A
EAMM-A-E32-57A	63.8	76.4	36.9	5	55	288	550 966 EAMM-A-E32-57A
EAMM-A-E48-52B					121	142	556 994 EAMM-A-E48-52B
EAMM-A-E48-52C					135	142	556 995 EAMM-A-E48-52C
EAMM-A-E48-55A					57.2	523	550 969 EAMM-A-E48-55A
EAMM-A-E48-57A	64	64	32		58.5	534	550 970 EAMM-A-E48-57A
EAMM-A-E48-44A-70A	65	64	32		60	591	550 971 EAMM-A-E48-44A-70A
EAMM-A-E48-87A					87.7	1278	550 972 EAMM-A-E48-87A
EAMM-A-E48-100A					91.2	1492	550 973 EAMM-A-E48-100A
EAMM-A-E48-40G	64	64	32	63.5	542	550 968 EAMM-A-E48-40G	
EAMM-A-E72-62B	105.1	127.3	60.8	8	150	2800	556 996 EAMM-A-E72-62B
EAMM-A-E72-70A	105.6	114.8			98.7	2362	550 975 EAMM-A-E72-70A
EAMM-A-E72-87A					100.2	3032	550 977 EAMM-A-E72-87A
EAMM-A-E72-100A					103.7	3235	550 978 EAMM-A-E72-100A
EAMM-A-E72-60G					106.9	3182	550 974 EAMM-A-E72-60G
EAMM-A-E72-80G					106.9	3183	550 976 EAMM-A-E72-80G

 Note

Permissible axis/motor combinations

➔ 54

Spindle axes DGE

Accessories

FESTO

Parallel kit EAMM-U-...

Material:

Housing: Aluminium

Clamping component, clamping sleeve, toothed belt gearwheel:

Steel, corrosion resistant

Toothed belt: Polychloroprene

Screws: Galvanised steel

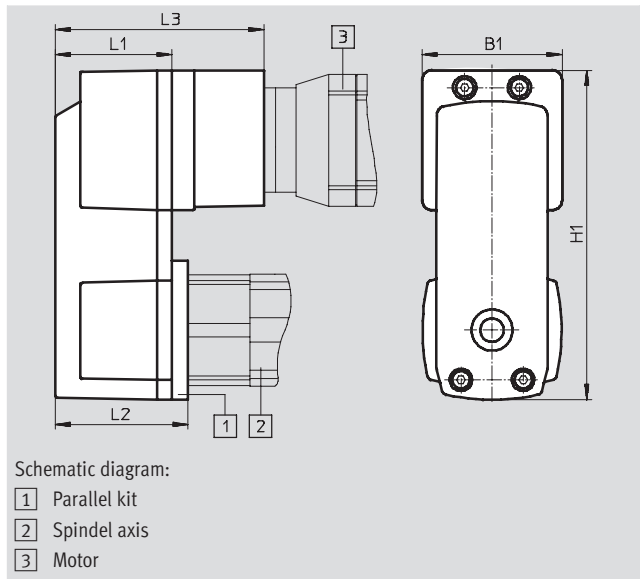

General technical data						
EAMM-U-...	E32-			E48-		
	42B	42C	55A	52B	52C	70A
Transferable torque [Nm]	3			5.5		
No-load drive torque [Nm]	0.1			0.3		
Mass moment of inert [kgmm ²]	10.22			71.138		
Max. speed [1/min]	3000					
Mounting position	Any					

Operating and environmental conditions		
Ambient temperature [°C]	0 ... 50	
Storage temperature [°C]	-25 ... +60	
Protection class ¹⁾	IP40	
Relative air humidity [%]	0 ... 95	

1) Only with combined attachment of motor and axis

Dimensions and ordering data								
Type	B1	H1	L1	L2	L3	Weight [g]	Part No.	Type
EAMM-U-E32-42B	56.4	132.7	47	53.5	84	660	543 228	EAMM-U-E32-42B
EAMM-U-E32-42C					97	690	543 229	EAMM-U-E32-42C
EAMM-U-E32-55A					-	540	543 230	EAMM-U-E32-55A
EAMM-U-E48-52B	85.8	189.9	58	66.5	106	1700	543 232	EAMM-U-E48-52B
EAMM-U-E48-52C					120	1800	543 233	EAMM-U-E48-52C
EAMM-U-E48-70A					-	1300	543 234	EAMM-U-E48-70A

- - Note
 Permissible axis/motor combinations
 → 57

Spindle axes DGE

Accessories

FESTO

Foot mounting HP (order code F)

Material:
Galvanised steel
Free of copper, PTFE and silicone



HP-25

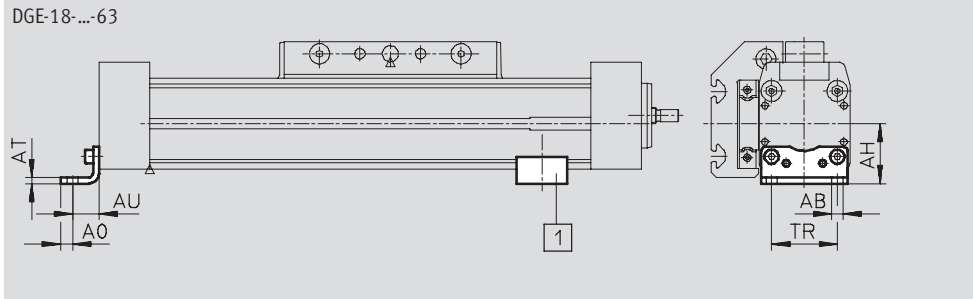

Dimensions and ordering data									
for size	AB ∅	AH	A0	AT	AU	TR	Weight [g]	Part No.	Type
18	5.5	24	4.8	3	13.3	24	70	158 472	HP-18
25	5.5	29.5	6	3	13	32.5	61	150 731	HP-25
40	6.6	46	8.5	5	17.5	45	188	150 733	HP-40
63	11	69	13.5	6	28	75	305	150 735	HP-63

Central support MUP (order code M)

Material:
Galvanised steel
Free of copper, PTFE and silicone



MUP-40

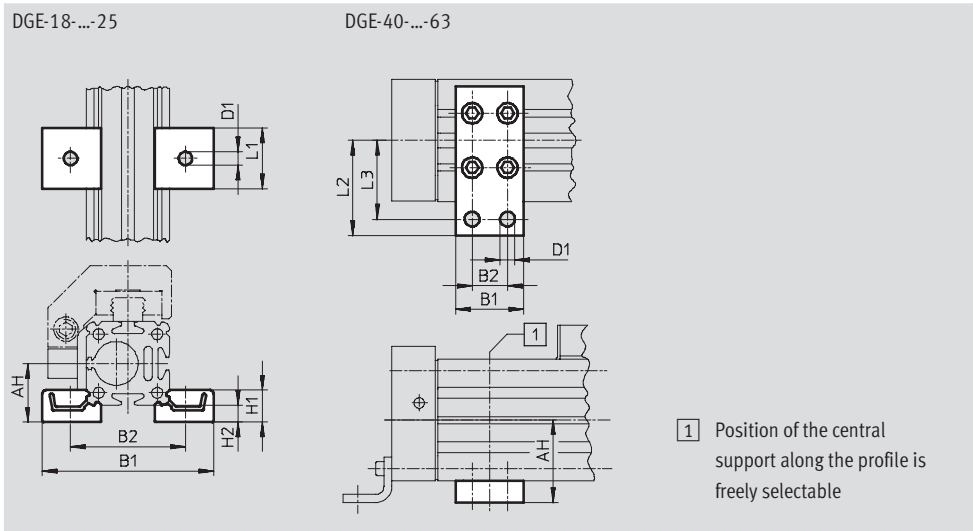

Dimensions and ordering data												
for size	AH	B1	B2	D1 ∅	H1	H2	L1	L2	L3	Weight [g]	Part No.	Type
18	24	70.5	47	5.5	13	7	25	-	-	33	150 736	MUP-18/25
25	29.5	81	58	5.5	13	7	25	-	-	33	150 736	MUP-18/25
40	46	35	22	6.6	-	-	-	47	40	126	150 738	MUP-40
63	69	50	26	11	-	-	-	77	65	340	150 800	MUP-63

Spindle axes DGE

Accessories



Foot mounting HHP

for heavy-duty guide

(order code F)

Material:

Galvanised steel



Central support MUP

for heavy-duty guide

(order code M)

Material:

Galvanised steel

Free of copper, PTFE and silicone

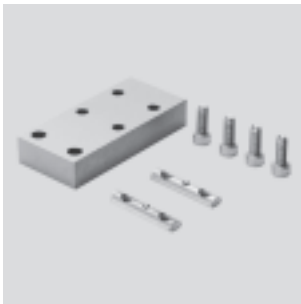

DGE-...-HD18/-HD25/-HD40

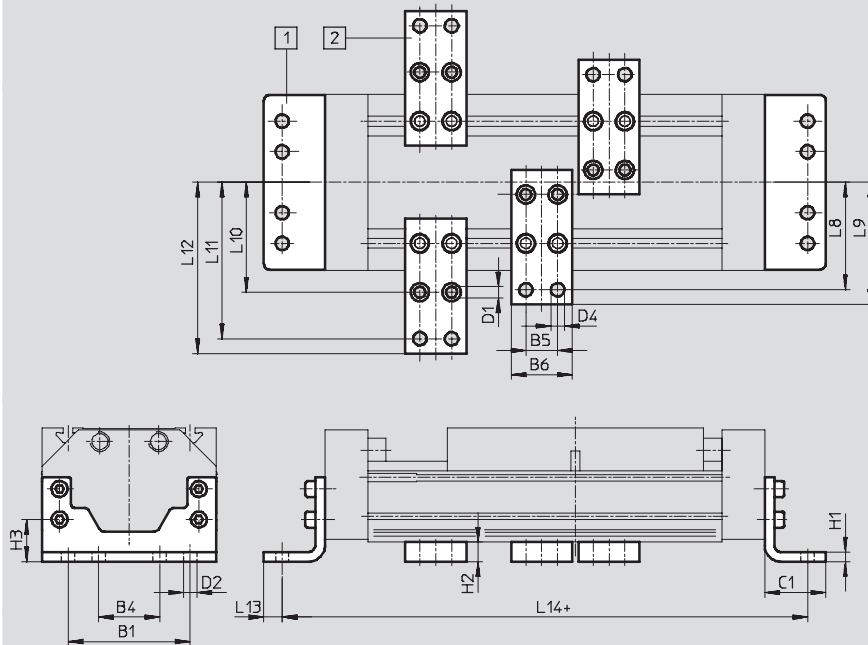

- 1 Foot mounting HHP
- 2 Central support MUP

+ = plus stroke length

Dimensions and ordering data											
for heavy-duty guide	B1	B4	B5	B6	C1	D1	D2	D4	H1	H2	H3
HD18	80	40	22	35	34	5.5	6.6	6.6	8	14	26.8
HD25	100	50	26	50	50	9	11	11	8	16	34.5
HD40	140	70	26	50	50	9	11	11	10	16	37

for heavy-duty guide	L8	L9	L10	L11	L12	L13	L14	Weight [g]	Part No.	Type
HD18	68	75	64	92	99	9	290	357	161 993	HHP-18
								126	150 738	MUP-40
HD25	88	100	90	128	140	15	380	794	161 994	HHP-25
								347	150 739	MUP-50
HD40	108	120	110	148	160	15	424	1318	161 995	HHP-40
								347	150 739	MUP-50

Spindle axes DGE

Accessories

Shock absorber YSR-...-C (order code C)

Material:
Housing: galvanised steel; piston rod:
high-alloy steel,
seals: nitrile rubber, polyurethane
Free of copper, PTFE and silicone



 Note
Shock absorber YSRW with
progressive characteristics
→ Internet: ysrw

Ordering data		Part No.	Type
for size	Weight [g]		
18	30	34 571	YSR-8-8-C
25	70	34 572	YSR-12-12-C
40	140	34 573	YSR-16-20-C
63	240	34 574	YSR-20-25-C

Shock absorber retainer KYP (order code C)

Material:
Retainer: Aluminium
Sleeve: Corrosion resistant steel



1 Shock absorber retainer KYP
(if the retainer is in contact with the end cap, i.e. cap serves to secure position, the entire stroke length can be utilised)

2 Shock absorber YSR-...-C

3 Position retainer
(included in scope of delivery) either behind or underneath the shock absorber retainer KYP

Dimensions and ordering data							
for size	B8	D1	D5	H2	H4	Weight [g]	Part No. Type
18	14	M12x1	M4	50.5	4.5	66	158 907 KYP-18
25	19	M16x1	M5	69.5	6	95	158 908 KYP-25
40	32	M22x1.5	M5	102	8	209	158 910 KYP-40
63	44	M26x1.5	M10	152.5	11.5	609	158 912 KYP-63

Spindle axes DGE

Accessories

FESTO

Emergency buffer NPE (order code A)

Material:
Polyurethane

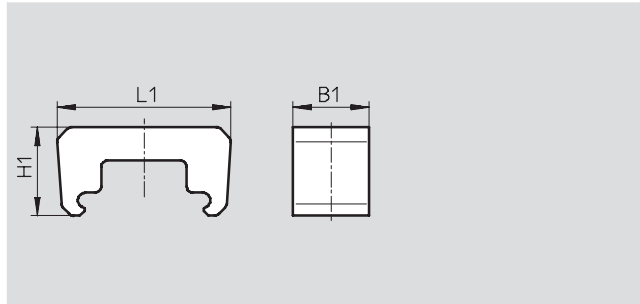
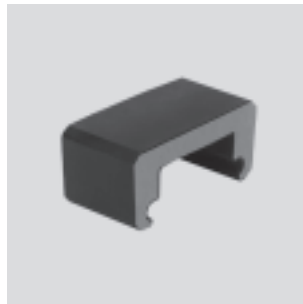

Dimensions and ordering data						
for size	B1	L1	H1	Weight [g]	Part No.	Type
18	15	43.1	28.5	6	193 901	NPE-18
25	25	57	29	12	193 902	NPE-25
40	40	80.5	36	41	193 904	NPE-40
63	60	128.6	55	152	193 906	NPE-63

-  - Note
The emergency buffer can only be used in conjunction with shock absorber retainer KYP.
→ 63
(A threaded pin and nut are not required.)

Shock absorber DG-GA for protected version GA (order code E)

Material:
Housing: galvanised steel; piston rod: high-alloy steel,
seals: nitrile rubber, polyurethane
Free of copper, PTFE and silicone



Ordering data			
for size	Weight [g]	Part No.	Type
25	70	192 875	DG-GA-25-YSR
40	140	192 877	DG-GA-40-YSR

Spindle axes DGE

Accessories

FESTO

Shock absorber kit YHD

for heavy-duty guide

(order code D)

Material:

Housing: Galvanised steel

Seals: TPE-U(PU) NBR

Free of copper, PTFE and silicone



Ordering data		Part No.	Type
for heavy-duty guide	Weight [g]		
HD18	203	174 544	YHD-18
HD25	293	174 545	YHD-25
HD40	515	174 546	YHD-40

Spindle axes DGE

Accessories

Sensor bracket HWS

for inductive proximity sensors

(order code T)

Material:

Galvanised steel



Switching lug SF

(order code L)

Material:

Galvanised steel

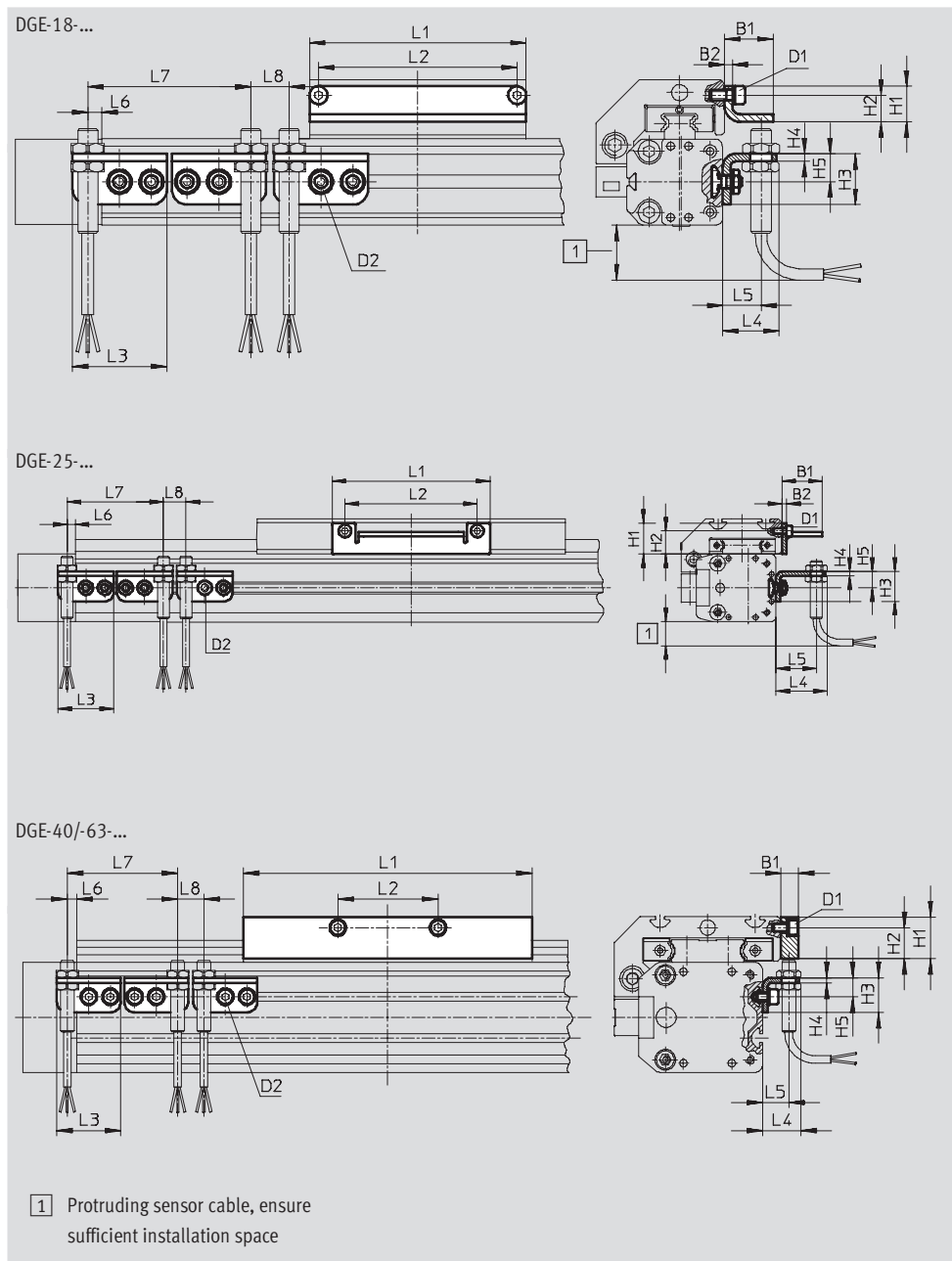

Spindle axes DGE

Accessories

FESTO



Dimensions and ordering data														
for size	D1	D2	B1	B2	H1	H2	H3	H4	H5	L1	L2	L3	L4	L5
18	M4	M5	19	3	14	10.5	20	3	11	85	78	37	22.5	15
25	M5	M5	27	3	20.5	15.3	20	3	11	105	88	37	34.5	27
40	M5	M5	10	–	24	18	20	3	11	167	58	37	22.5	15
63	M8	M5	10	–	35	25	20	3	11	230	72	37	22.5	15

for size	L6 max.	L7 min.	L8 min.	Weight [g]	Part No.	Type
18	5.5	64	15	30	188 968	HWS-18/25-M8
				60	188 964	SF-18
25	5.5	64	15	30	540 780	HWS-25-MAB-M8
				80	540 430	SF-25-MAB
40	5.5	64	15	40	188 969	HWS-40-M8
				310	188 966	SF-40
63	5.5	64	15	40	188 970	HWS-63-M8
				630	188 967	SF-63

Spindle axes DGE

Accessories

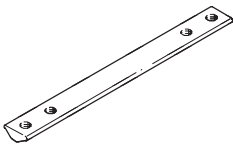
FESTO

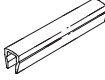
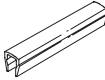

Ordering data				Technical data → Internet: mounting attachment		
	for size	Remarks	Order code	Part No.	Type	PU ¹⁾
Slot nut NST						
	18, 25	For mounting slot	Y	526 091	NST-HMV-M4	1
	40			150 914	NST-5-M5	1
	63			150 915	NST-8-M6	1
	HD18, HD25	For heavy-duty guide: mounting slot	Y	150 914	NST-5-M5	1
	HD40			150 915	NST-8-M6	1
	HD18	For heavy-duty guide: HD underneath	U	150 914	NST-5-M5	1
	HD25, HD40			150 915	NST-8-M6	1
Slot nut NSTL						
	25	For slide	X	158 410	NSTL-25	1
	40			158 412	NSTL-40	1
	63			158 414	NSTL-63	1
	HD18	For heavy-duty guide: slide	X	161 020	NSTH-18	1
	HD25			161 021	NSTH-25	1
	HD40			161 022	NSTH-40	1
Centring pin/sleeve ZBS/ZBH						
	18	For slide	Z	150 928	ZBS-5	10
	25 ... 63			150 927	ZBH-9	10
Central mounting SLZZ						
	HD18	For heavy-duty guide: slide	Q	150 901	SLZZ-25/16	1
	HD25					
	HD40					
Slot cover ABP						
	40	For mounting slot each 0.5 m	B	151 681	ABP-5	2
	63			151 682	ABP-8	
	HD18, HD25	For mounting slot at side and underneath, each 0.5 m		151 681	ABP-5	
	HD40			151 682	ABP-8	
Slot cover ABP-S						
	18 ... 63	For sensor slot each 0.5 m	S	151 680	ABP-5-S	2



1) Packaging unit quantity



Spindle axes DGE



Accessories

FESTO

Ordering data – Proximity sensors for T-slot, magneto-resistive						Technical data → Internet: smt	
	Type of mounting	Switch output	Electrical connection	Cable length [m]	Part No.	Type	
N/O contact							
	Insertable in the slot lengthwise, flush with the cylinder profile	PNP	Cable, 3-wire	2.5	175 436	SMT-8-PS-K-LED-24-B	
			Plug M8x1, 3-pin	0.3	175 484	SMT-8-PS-S-LED-24-B	
N/C contact							
	Insertable in the slot from above, flush with cylinder profile	PNP	Cable, 3-wire	7.5	543 873	SMT-8M-PO-24V-K7,5-OE	

Ordering data – Proximity sensors for T-slot, magnetic reed						Technical data → Internet: sme	
	Type of mounting	Switch output	Electrical connection	Cable length [m]	Part No.	Type	
N/O contact							
	Insertable in the slot lengthwise, flush with the cylinder profile	Contacting	Cable, 3-wire	2.5	150 855	SME-8-K-LED-24	
			Plug M8x1, 3-pin	0.3	150 857	SME-8-S-LED-24	
N/C contact							
	Insertable in the slot lengthwise, flush with the cylinder profile	Contacting	Cable, 3-wire	7.5	160 251	SME-8-O-K-LED-24	

Ordering data – Inductive proximity sensors M8						Technical data → Internet: sien	
	Electrical connection		Switch output	LED	Cable length [m]	Part No.	Type
	Cable	Plug M8					
Normally open contact							
	3-wire	–	PNP	■	2.5	150 386	SIEN-M8B-PS-K-L
	–	3-pin	PNP	■		150 387	SIEN-M8B-PS-S-L
Normally closed contact							
	3-wire	–	PNP	■	2.5	150 390	SIEN-M8B-PO-K-L
	–	3-pin	PNP	■		150 391	SIEN-M8B-PO-S-L

Ordering data – Connecting cables					Technical data → Internet: nebu	
	Electrical connection, left		Electrical connection, right	Cable length [m]	Part No.	Type
	Straight socket, M8x1, 3-pin		Cable, open end, 3-wire	2.5	541 333	NEBU-M8G3-K-2.5-LE3
				5	541 334	NEBU-M8G3-K-5-LE3
	Angled socket, M8x1, 3-pin		Cable, open end, 3-wire	2.5	541 338	NEBU-M8W3-K-2.5-LE3
				5	541 341	NEBU-M8W3-K-5-LE3