

Linear drives DGC



Linear drives DGC

Key features

FESTO

General

- Compact – fitting length relative to stroke
- Loads and devices can be directly mounted on the slide
- Three types of cushioning available:
 - Flexible cushioning
 - Pneumatic cushioning
 - Hydraulic cushioning
- All settings accessible from one side:
 - Precision end position adjustment
 - Position of proximity sensors
 - Mounting of drive
 - Speed regulation
 - Pneumatic end position cushioning

- Sealing system

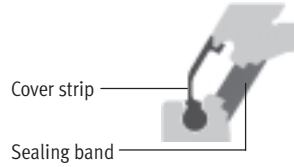

- Advantages of the sealing system
- Long strokes without restrictions
 - Virtually zero-leakage

Wide choice of variants

Basic design DGC-G



- Piston \varnothing 8 ... 63 mm
- Stroke lengths from 1 ... 8,500 mm
- Guide backlash = 0.2 mm
- For small loads
- Operating behaviour with torque load = Average

Plain-bearing guide DGC-GF



- Piston \varnothing 18 ... 63 mm
- Stroke lengths from 1 ... 8,500 mm
- Guide backlash = 0.05 mm
- For small and medium loads
- Operating behaviour with torque load = Average

Recirculating ball bearing guide DGC-KF



- Piston \varnothing 8 ... 63 mm
- Stroke lengths from 1 ... 8,500 mm
- Guide backlash = 0 mm
- For medium and large loads
- Precision mounting interface with stainless steel slide
- Operating behaviour with torque load = Very good

Recirculating ball bearing guide with protected guide DGC-KF-GP

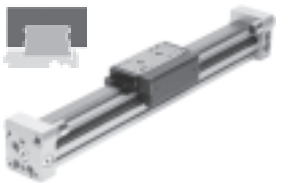

- Piston \varnothing 18 ... 40 mm
- Stroke lengths from 1 ... 8,500 mm
- Guide backlash = 0 mm
- The protected guide cleans the guide rail and protects the recirculating ball bearing guide by means of an additional wiper seal and lubrication unit

Passive guide axis DGC-FA



- Without drive
- Piston \varnothing 8 ... 63 mm
- Stroke lengths from 1 ... 8,500 mm
- Guide backlash = 0 mm
- Precision guide, suitable for DGC-KF. Can be used as machine component or as twin guide with DGC-KF

Passive guide axis with protected guide DGC-FA-GP



- Without drive
- Piston \varnothing 18 ... 40 mm
- Stroke lengths from 1 ... 8,500 mm
- Guide backlash = 0 mm
- The protected guide cleans the guide rail and protects the recirculating ball bearing guide by means of an additional wiper seal and lubrication unit

Linear drives DGC

Key features

Versatile

1 Supply ports

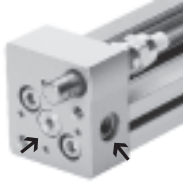

- Optional on two faces (on the end face or from the front)
- For DGC-G/DGC-GF/DGC-KF

2 Proximity sensor G/H/I/J



- Proximity sensors can be integrated, which means there is no projection. Cable can be guided through the slot behind a second sensor
- For DGC-G/DGC-GF/DGC-KF

3 Precision end position adjustment



- Between 0 ... 25 mm per side
- For DGC-GF/DGC-KF/DGC-FA

4 Profile mounting M

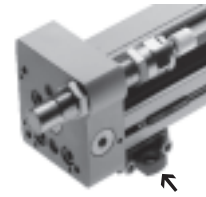

- Profile mounting remains on the base plate after the drive is dismantled. This means faster assembly and removal without repeat adjustment
- For DGC-G/DGC-GF/DGC-KF/DGC-FA

5 Mechanical end position limiter YWZ

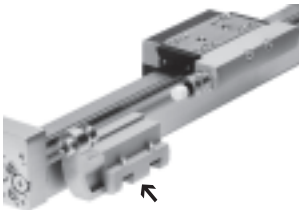

- For variable end position adjustment, e.g. for format adjustments
- The end stop can be mounted at any position within the stroke
- For DGC-GF/DGC-KF/DGC-FA

6 Intermediate position Z1/Z2/Z3



- Permits variable intermediate positions
- The intermediate position module can be mounted at any position within the stroke
- Precision repetition accuracy (0.02 mm) with highly dynamic response
- For DGC-KF

Driver FK

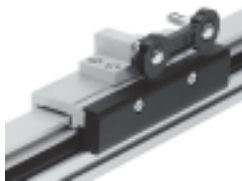

- Compensates inaccuracies during mounting of the linear drive and external guide
- Max. offset 2.5 mm
- For DGC-G

Example

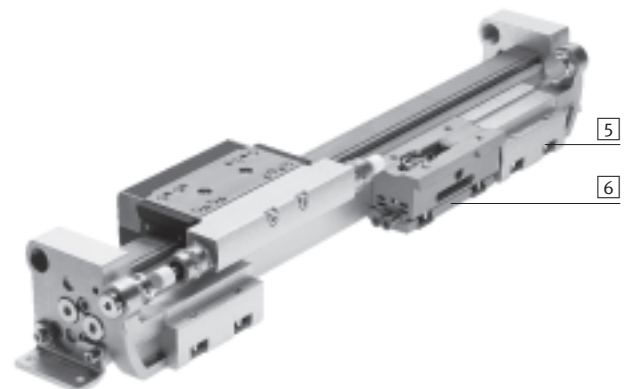
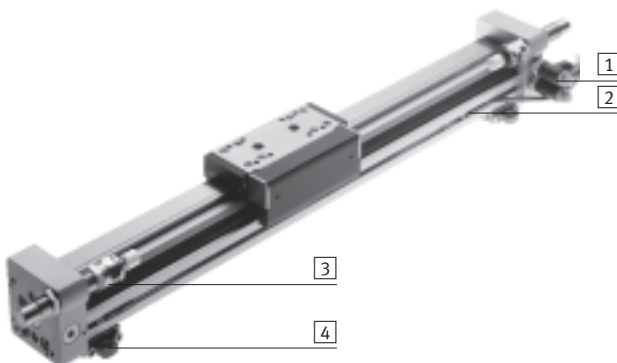





Linear drives DGC

Key features

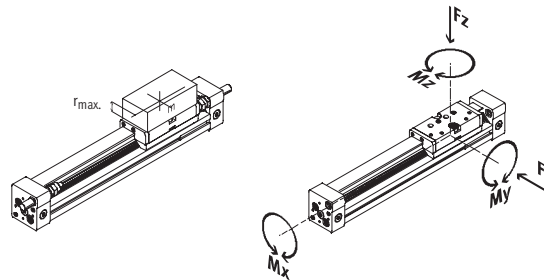
FESTO

Product variants



| | Piston \varnothing [mm] | Theoretical force at 6 bar [N] | Max. perm. effective load ¹⁾ m [kg] / at max. load distance r [mm] | Guide characteristics | | | | | → Page/ Internet |
|---|------------------------------|--------------------------------------|--|-----------------------|-----------|------------|------------|------------|---------------------|
| | | | | Fy [N] | Fz [N] | Mx [Nm] | My [Nm] | Mz [Nm] | |
| Basic design DGC-G | | | | | | | | | |
|  | 8 | 30 | 0.06 / 25 | 150 | 150 | 0.5 | 2 | 2 | 8 |
| | 12 | 68 | 0.1 / 35 | 300 | 300 | 1.3 | 5 | 5 | |
| | 18 | 153 | - / - | 70 | 340 | 1.9 | 12 | 4 | |
| | 25 | 295 | - / - | 180 | 540 | 4 | 20 | 5 | |
| | 32 | 483 | - / - | 250 | 800 | 9 | 40 | 12 | |
| | 40 | 754 | - / - | 370 | 1,100 | 12 | 60 | 25 | |
| | 50 | 1,178 | - / - | 480 | 1,600 | 20 | 150 | 37 | |
| 63 | 1,870 | - / - | 650 | 2,000 | 26 | 150 | 48 | | |
| Plain-bearing guide DGC-GF | | | | | | | | | |
|  | 18 | 153 | 3 / 35 | 440 | 540 | 3.4 | 20 | 8.5 | 24 |
| | 25 | 295 | 8 / 50 | 640 | 1,300 | 8.5 | 40 | 20 | |
| | 32 | 483 | 11 / 50 | 900 | 1,800 | 15 | 70 | 33 | |
| | 40 | 754 | 15 / 50 | 1,380 | 2,000 | 28 | 110 | 54 | |
| | 50 | 1,178 | 48 / 50 | 1,500 | 2,870 | 54 | 270 | 103 | |
| | 63 | 1,870 | 75 / 50 | 2,300 | 4,460 | 96 | 450 | 187 | |
| Recirculating ball bearing guide DGC-KF/DGC-KF-GP | | | | | | | | | |
|  | 8 | 30 | 0.7 / 25 | 300 | 300 | 1.7 | 4.5 | 4.5 | 40 |
| | 12 | 68 | 1.8 / 35 | 650 | 650 | 3.5 | 10 | 10 | |
| | 18 | 153 | 10 / 35 | 1,850 | 1,850 | 16 | 51 | 51 | |
| | 25 | 295 | 30 / 50 | 3,050 | 3,050 | 36 | 97 | 97 | |
| | 32 | 483 | 30 / 50 | 3,310 | 3,310 | 54 | 150 | 150 | |
| | 40 | 754 | 50 / 50 | 6,890 | 6,890 | 144 | 380 | 380 | |
| | 50 | 1,178 | 90 / 50 | 6,890 | 6,890 | 144 | 634 | 634 | |
| 63 | 1,870 | 130 / 50 | 15,200 | 15,200 | 529 | 1,157 | 1,157 | | |
| Passive guide axis without drive DGC-FA/DGC-FA-GP | | | | | | | | | |
|  | 8 | 0 | 0.7 / 25 | 300 | 300 | 1.7 | 4.5 | 4.5 | dgc-fa |
| | 12 | 0 | 1.8 / 35 | 650 | 650 | 3.5 | 10 | 10 | |
| | 18 | 0 | 10 / 35 | 1,850 | 1,850 | 16 | 51 | 51 | |
| | 25 | 0 | 30 / 50 | 3,050 | 3,050 | 36 | 97 | 97 | |
| | 32 | 0 | 30 / 50 | 3,310 | 3,310 | 54 | 150 | 150 | |
| | 40 | 0 | 50 / 50 | 6,890 | 6,890 | 144 | 380 | 380 | |
| | 50 | 0 | 90 / 50 | 6,890 | 6,890 | 144 | 634 | 634 | |
| 63 | 0 | 130 / 50 | 15,200 | 15,200 | 529 | 1,157 | 1,157 | | |

1) At v = 0.5 m/s with shock absorber YSR or YSRW

Linear drives DGC

Key features

Interchangeability with linear drive DGPL

Special foot mountings for the drive DGC allow the linear drive DGPL to be replaced with the linear drive DGC-GF/-KF with identical slide position and identical interfaces.

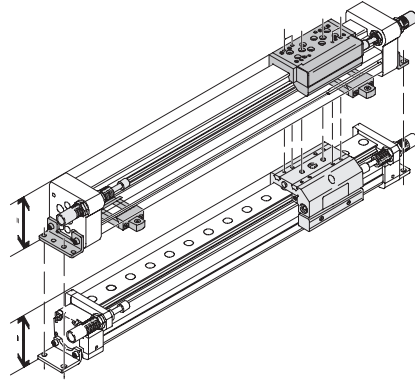

| Slide position | Linear drive DGPL | Linear drive DGC-GF/-KF | Foot mounting required → 60 |
|----------------|-------------------|-------------------------|----------------------------------|
| Top | | | Type HPC-...-SO/ HPC-...-S |
| Rear | | | Type HPC-...-SH/ HPC-...-S |

Alternatives

Electro-mechanical drives

Toothed belt axes DGE-ZR

Spindle axes DGE-SP

Rodless cylinders,
magnetically coupled
Linear drives DGO



Advantages:

Positioning drive for approaching several positions

→ Internet: dge-zr

Positioning drive for approaching several positions

→ Internet: dge-sp

Hermetically sealed drive

→ Internet: dgo

Linear drives DGC

Key features

FESTO

System product for handling and assembly technology

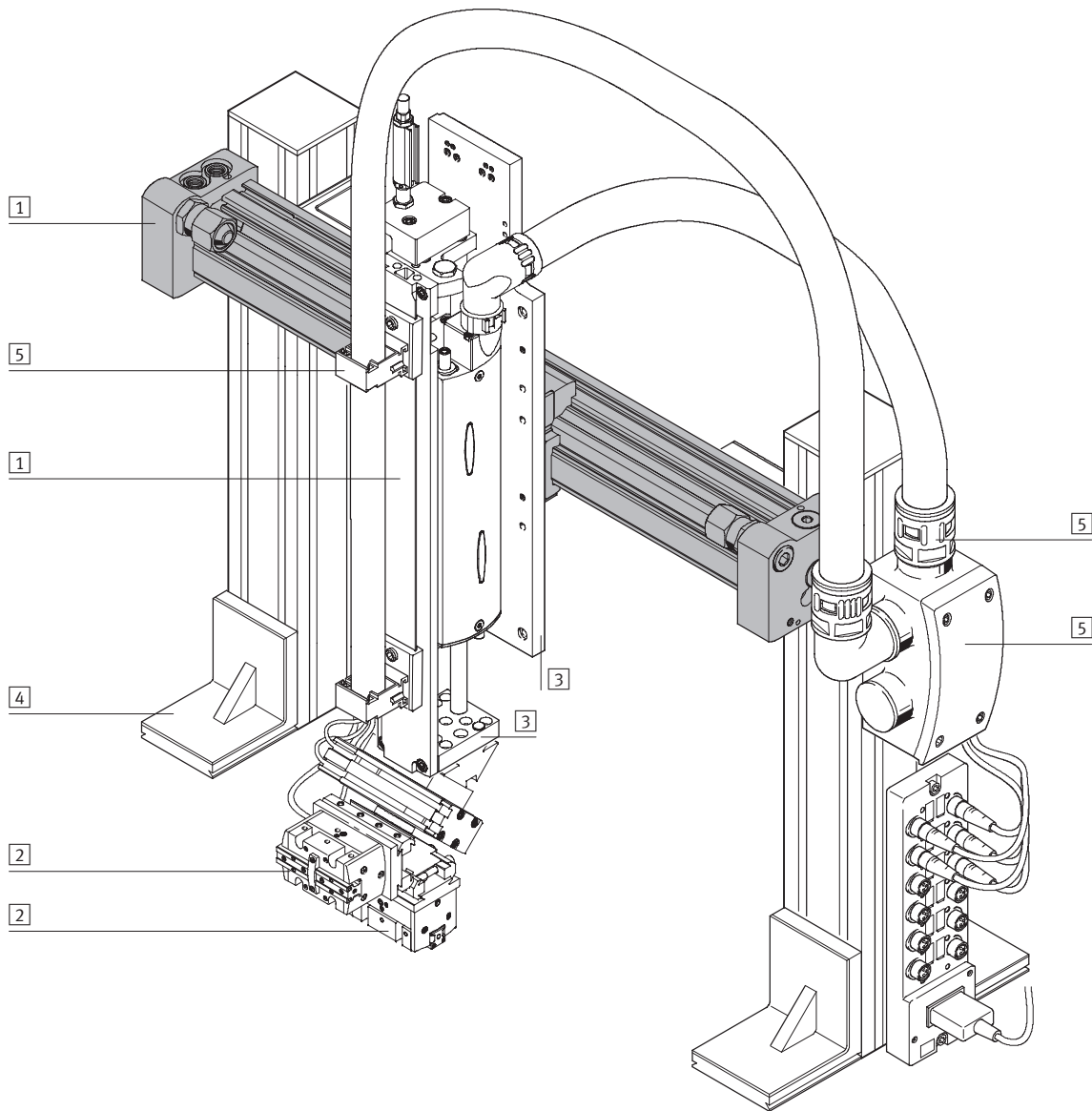

Linear drives DGC

Key features

| System elements and accessories | | | |
|---------------------------------|---------------------------|---|------------------------|
| | Brief description | → Page/Internet | |
| 1 | Drive units | Wide range of combinations possible within handling and assembly technology | drive |
| 2 | Grippers | Diverse variation options in handling and assembly technology | gripper |
| 3 | Adapters | For drive/drive and drive/gripper combinations | adapter kit |
| 4 | Basic mounting components | Profiles and profile connectors as well as profile/drive connectors | basic component |
| 5 | Installation components | For achieving a clear-cut, safe layout for electrical cables and tubing | installation component |
| - | Axes | Wide range of combinations possible within handling and assembly technology | axes |
| - | Motors | Servo and stepper motors, with or without gear unit | motor |

Linear drives DGC-G

Peripherals overview

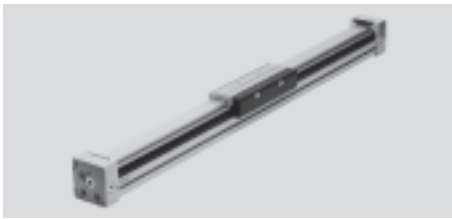

DGC-8/-12

-  - Note
 1) End stops or shock absorbers must not be removed.

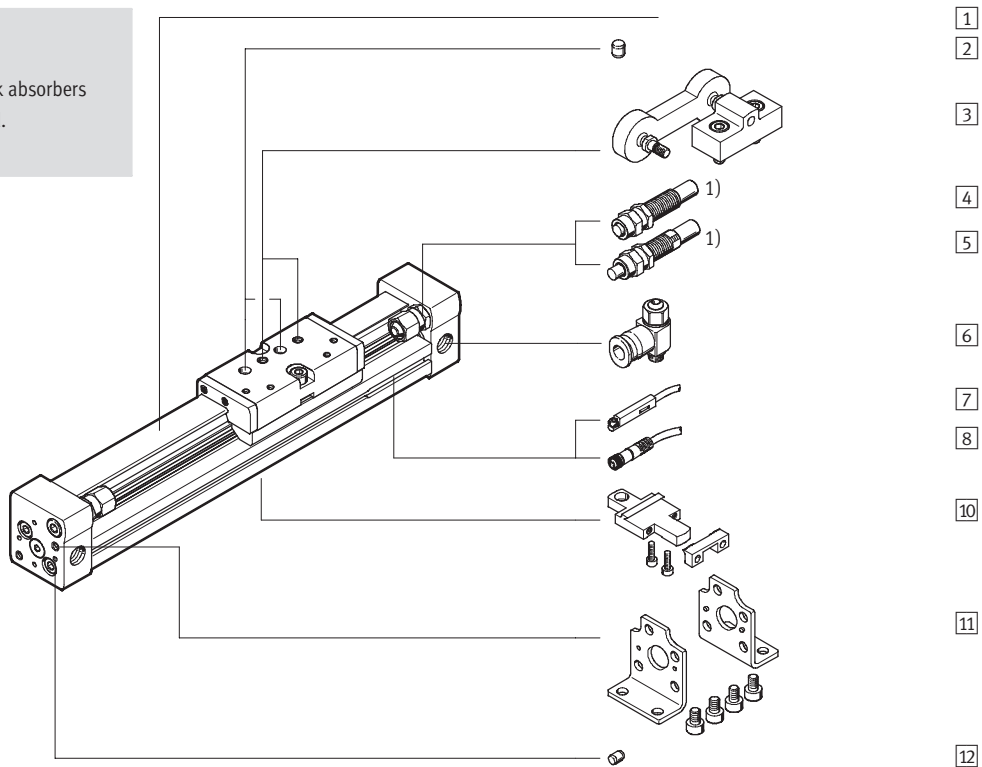

DGC-18 ... 63

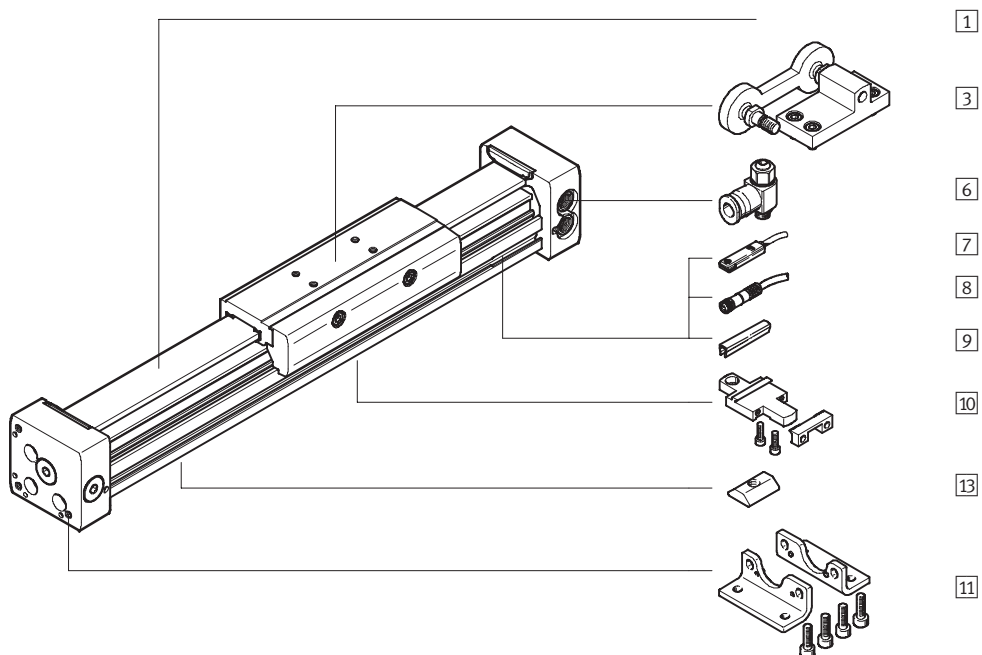

Linear drives DGC-G

Peripherals overview

| Variants and accessories | | | |
|---------------------------------------|--------------------------|--|-----------------|
| Type | For piston \varnothing | Brief description | → Page/Internet |
| 1) Linear drive DGC-G | 8 ... 63 | Linear drive without accessories, basic design | 12 |
| 2) Centring pin ¹⁾ ZBS | 8, 12 | For centring loads and attachments on the slide | 72 |
| 3) Driver FK | 8 ... 63 | Compensates inaccuracies in the mounting of the linear drive and external guide | 66 |
| – Cushioning P | 8, 12 | Non-adjustable, flexible cushioning. Used only at low speeds | 23 |
| – Cushioning PPV | 18 ... 63 | Adjustable pneumatic end position cushioning. Used at medium speeds | 23 |
| 4) Shock absorber YSR | 8, 12 | Self-adjusting hydraulic shock absorber with spring return and linear cushioning characteristic | 23 |
| 5) Shock absorber YSRW | 8, 12 | Self-adjusting hydraulic shock absorber with spring return and progressive cushioning characteristic | 23 |
| 6) One-way flow control valve GRLA | 8 ... 63 | For regulating speed | 72 |
| 7) Proximity sensor G/H/I/J | 8 ... 63 | For sensing the slide position | 73 |
| 8) Cable with socket V | 8 ... 63 | For proximity sensor | 73 |
| 9) Slot cover L | 18 ... 63 | For protecting against ingress of dirt and securing proximity sensor cables | 72 |
| 10) Profile mounting M | 8 ... 63 | Simple and precise mounting option via dovetail connection | 64 |
| 11) Foot mounting F | 8 ... 63 | For mounting on end cap | 60 |
| 12) Centring pin ¹⁾ ZBS | 8, 12 | For centring the drive without foot mountings (user-specific) | 72 |
| 13) Slot nut B | 25 ... 63 | For mounting attachments | 72 |

1) Included in the scope of delivery of the drive

Linear drives DGC-G

Type codes

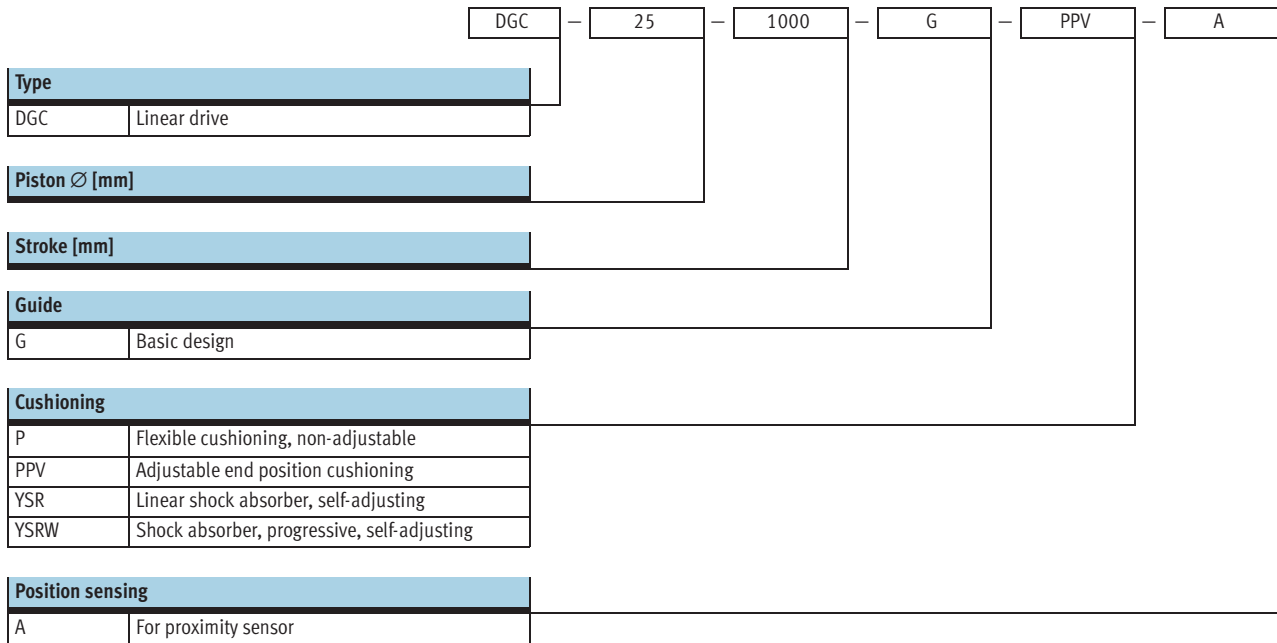

Linear drives DGC-G

Type codes



| | | + ZUB | - F | | | 2B | 2G | | 2L | |
|--------------------------|---|-------|-----|--|--|----|----|--|----|--|
| Accessories | | | | | | | | | | |
| ZUB | Accessories supplied loose | | | | | | | | | |
| Foot mounting | | | | | | | | | | |
| F | Foot mounting | | | | | | | | | |
| Profile mounting | | | | | | | | | | |
| ...M | Profile mounting | | | | | | | | | |
| Driver | | | | | | | | | | |
| FK | Moment compensator | | | | | | | | | |
| Slot nut | | | | | | | | | | |
| ...B | For mounting slot | | | | | | | | | |
| Proximity sensor | | | | | | | | | | |
| ...G | With cable, 2.5 m | | | | | | | | | |
| ...H | With plug | | | | | | | | | |
| ...I | Contactless with cable, 2.5 m | | | | | | | | | |
| ...J | Contactless, with plug | | | | | | | | | |
| Cable with socket | | | | | | | | | | |
| ...V | 2.5 m | | | | | | | | | |
| Slot cover | | | | | | | | | | |
| ...L | For sensor slot | | | | | | | | | |
| User manual | | | | | | | | | | |
| 0 | Express waiver – no operating instructions to be included | | | | | | | | | |

Linear drives DGC-G

Technical data

FESTO

Function

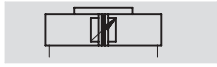

www.festo.com

Wearing parts kits
→ 23

- Ø - Diameter
8 ... 63 mm
- | - Stroke length
1 ... 8,500 mm

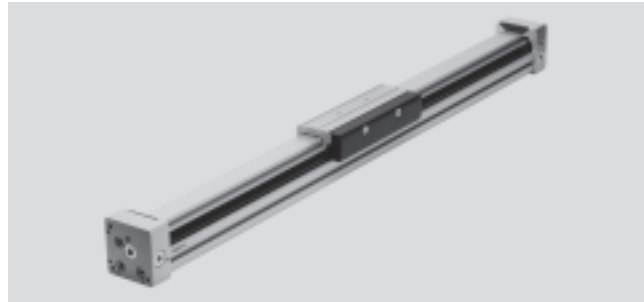

| General technical data | | | | | | | | | | |
|---------------------------------------|--------|--|-------------|-------------|-------------------------|------|------|-------------|------|------|
| Piston Ø | | 8 | 12 | 18 | 25 | 32 | 40 | 50 | 63 | |
| Stroke | [mm] | 1 ... 1,500 | 1 ... 2,000 | 1 ... 3,000 | 1 ... 8,500 | | | 1 ... 5,000 | | |
| Pneumatic connection | | M5 | | | G1/8 | | G1/4 | | G3/8 | |
| Mode of operation | | Double-acting | | | | | | | | |
| Design | | Rodless drive | | | | | | | | |
| Driver principle | | Slotted cylinder, mechanically coupled | | | | | | | | |
| Guide | | Basic design | | | | | | | | |
| Mounting position | | Any | | | | | | | | |
| Cushioning → 15 | P | Non-adjustable at either end | | | - | | | | | |
| | PPV | - | | | Adjustable at both ends | | | | | |
| | YSR... | Self-adjusting at both ends | | | - | | | | | |
| Cushioning length with PPV cushioning | [mm] | - | | | 16.5 | 15.5 | 17.5 | 29.5 | 29.8 | 31.1 |
| Position sensing | | For proximity sensor | | | | | | | | |
| Type of mounting | | Profile mounting | | | | | | | | |
| | | Foot mounting | | | | | | | | |
| | | Direct mounting | | | | | | | | |
| Max. speed | [m/s] | 1 | 1.2 | 3 | | | | | | |

– | – Note: This product conforms with the ISO 1179-1 standard and the ISO 228-1 standard.

| Operating and environmental conditions | | | | | | | | | |
|--|-------|---|----|-------------|---------|----|-----------|----|----|
| Piston Ø | | 8 | 12 | 18 | 25 | 32 | 40 | 50 | 63 |
| Operating pressure | [bar] | 2.5 ... 8 | | | 2 ... 8 | | 1.5 ... 8 | | |
| Operating medium | | Filtered compressed air, lubricated or unlubricated | | | | | | | |
| Ambient temperature ¹⁾ | [°C] | +5 ... +60 | | -10 ... +60 | | | | | |
| Corrosion resistance class CRC ²⁾ | | 2 | | | | | | | |
| Certification | | C-Tick | | | | | | | |

1) Note operating range of proximity sensors

2) Corrosion resistance class 2 to Festo standard 940 070

Components subject to moderate corrosion stress. Externally visible parts with primarily decorative surface requirements which are in direct contact with a normal industrial environment or media such as coolants or lubricating agents.

| Forces [N] and impact energy [J] | | | | | | | | | |
|----------------------------------|--|------|----|-----|-----|-----|-----|-------|-------|
| Piston Ø | | 8 | 12 | 18 | 25 | 32 | 40 | 50 | 63 |
| Theoretical force at 6 bar | | 30 | 68 | 153 | 295 | 483 | 754 | 1,178 | 1,870 |
| Impact energy at end positions | | → 15 | | | | | | | |

| Weights [g] | | | | | | | | | |
|------------------------------------|--|-----|-----|-----|-------|-------|-------|-------|--------|
| Piston Ø | | 8 | 12 | 18 | 25 | 32 | 40 | 50 | 63 |
| Basic weight with 0 mm stroke | | 170 | 290 | 546 | 1,004 | 2,126 | 4,121 | 9,050 | 14,040 |
| Additional weight per 10 mm stroke | | 9 | 12 | 22 | 34 | 54 | 77 | 116 | 150 |
| Moving load | | 36 | 65 | 178 | 287 | 508 | 1,312 | 2,850 | 4,330 |

Linear drives DGC-G

Technical data

Adjustable end position range d [mm]

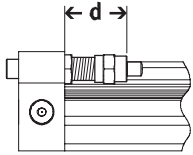

- - Note

The permissible kinetic energy decreases if the stroke is reduced

with PPV adjustable cushioning at both ends.

| Piston Ø | 8 | 12 | 18 | 25 | 32 | 40 | 50 | 63 |
|---------------------|---------------|---------------|----|----|----|----|----|----|
| Cushioning P/PPV | 11.3 ... 16.3 | 12.7 ... 17.7 | - | | | | | |
| Cushioning YSR/YSRW | 12.8 ... 22.8 | 14 ... 24 | - | | | | | |

Materials

Sectional view

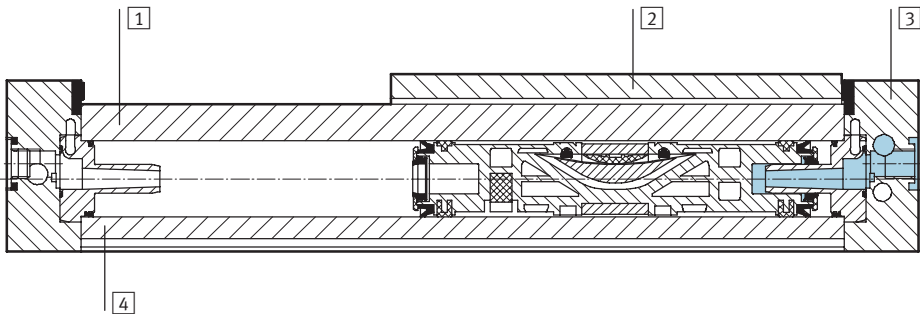

| Linear drives | | |
|---------------|--------------------------|--------------------|
| 1 | Guide rail | Anodised aluminium |
| 2 | Slide | Anodised aluminium |
| 3 | End cap | Anodised aluminium |
| 4 | Cylinder barrel | Anodised aluminium |
| - | Piston seal | Polyurethane |
| - | Sealing band/cover strip | Polyurethane |
| - | Slide elements | Polyacetate |

Influence of ferritic materials on proximity sensors

Ferritic materials (steel parts or panels) directly next to the proximity sensors can cause sensing

malfunctions. The following safety distances must be observed.

The distance depends on the position of the proximity sensor (see 1 and 2).

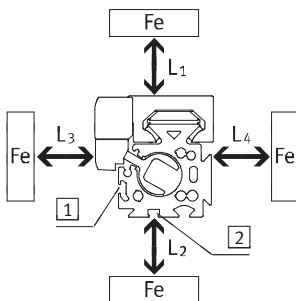

| Piston Ø | | 8 | 12 | 18 | 25 | 32 | 40 | 50 | 63 |
|-------------|--------|----|----|----|----|----|----|----|----|
| Distance L1 | 1 [mm] | 0 | 0 | 0 | 0 | 0 | 0 | 0 | 0 |
| | 2 [mm] | - | - | 0 | 0 | 0 | 0 | 0 | 0 |
| Distance L2 | 1 [mm] | 20 | 10 | 10 | 10 | 0 | 0 | 0 | 0 |
| | 2 [mm] | - | - | 25 | 25 | 25 | 25 | 25 | 25 |
| Distance L3 | 1 [mm] | 30 | 25 | 25 | 25 | 25 | 25 | 25 | 25 |
| | 2 [mm] | - | - | 10 | 10 | 0 | 0 | 0 | 0 |
| Distance L4 | 1 [mm] | 0 | 0 | 0 | 0 | 0 | 0 | 0 | 0 |
| | 2 [mm] | - | - | 0 | 0 | 0 | 0 | 0 | 0 |

Linear drives DGC-G

Technical data



Characteristic load values

The indicated forces and torques refer to the centre of the slide surface.

They must not be exceeded in the dynamic range. Special attention must be paid to the cushioning phase.

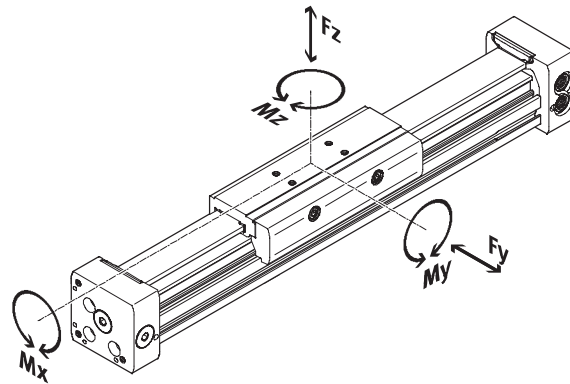

- - Note

In order to avoid frictional restraint of the guide in the case of the basic drive DGC-G when used in vertical mode and with a high torque load, the variant with the recirculating ball bearing guide DGC-KF → 40 is recommended.

If the drive is subjected to more than two of the indicated forces and torques simultaneously, the following equation must be satisfied in addition to the indicated maximum loads:

$$\frac{F_y}{F_{y_{max}}} + \frac{F_z}{F_{z_{max}}} + \frac{M_x}{M_{x_{max}}} + \frac{M_y}{M_{y_{max}}} + \frac{M_z}{M_{z_{max}}} \leq 1$$

Permissible forces and torques

| Piston Ø | 8 | 12 | 18 | 25 | 32 | 40 | 50 | 63 |
|-------------------------------------|-----|-----|-----|-----|-----|-------|-------|-------|
| F _y _{max.} [N] | 150 | 300 | 70 | 180 | 250 | 370 | 480 | 650 |
| F _z _{max.} [N] | 150 | 300 | 340 | 540 | 800 | 1,100 | 1,600 | 2,000 |
| M _x _{max.} [Nm] | 0.5 | 1.3 | 1.9 | 4 | 9 | 12 | 20 | 26 |
| M _y _{max.} [Nm] | 2 | 5 | 12 | 20 | 40 | 60 | 150 | 150 |
| M _z _{max.} [Nm] | 2 | 5 | 4 | 5 | 12 | 25 | 37 | 48 |

- - Note

Sizing software

ProDrive

→ www.festo.com

Linear drives DGC-G

Technical data



Maximum permissible piston speed v as a function of effective load m

Piston \varnothing 8/12 with P cushioning

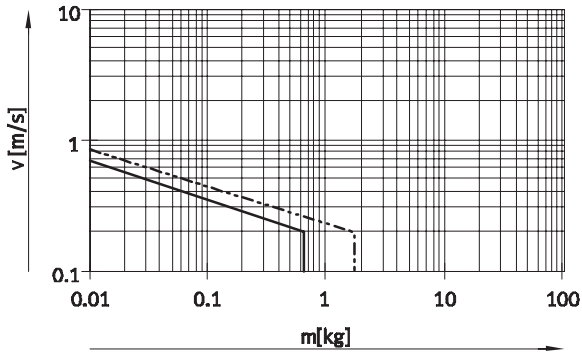

Piston \varnothing 18 ... 63 with PPV cushioning

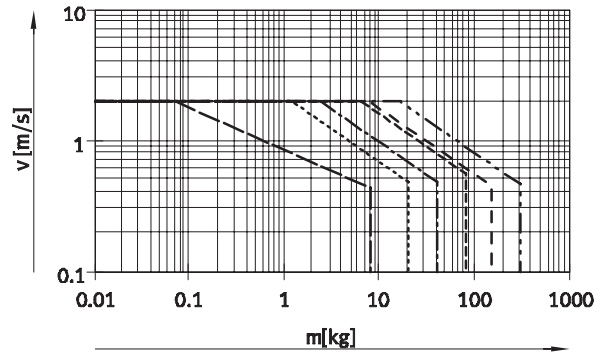

Piston \varnothing 8/12 with YSR cushioning

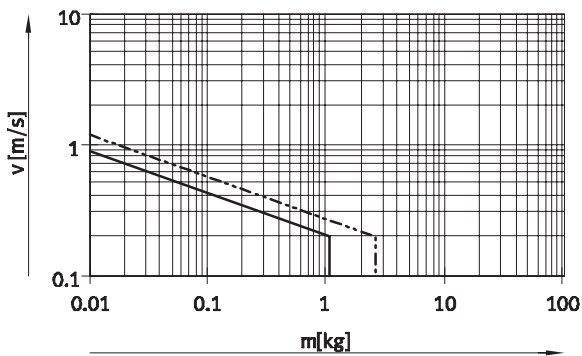

Piston \varnothing 8/12 with YSRW cushioning

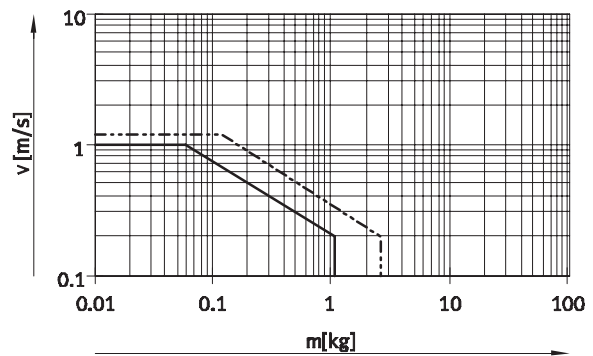

- \varnothing 8 - - - \varnothing 18 - - - - \varnothing 40
- - - \varnothing 12 - · - · \varnothing 25 - - - \varnothing 50
- · - · \varnothing 32 - - - \varnothing 63

Note
This data represents the maximum values that can be achieved. Values fluctuate in practice relative to the position of the effective load and mounting position.

Operating range of cushioning

The end position cushioning must be adjusted to ensure jerk-free operation. If the operating conditions are outside the permissible range, the

load to be moved must be cushioned using suitable equipment (external shock absorbers), preferably at the centre of gravity of the mass.

Note
To avoid distortion in the slide, the bearing surfaces of the attachments must maintain a flatness of at least 0.03 mm.

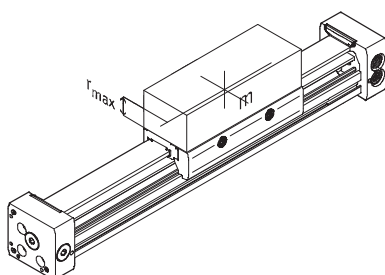

Data for horizontal mounting position:

| Piston \varnothing | 8 | 12 | 18 | 25 | 32 | 40 | 50 | 63 |
|-------------------------|----|----|----|----|----|----|----|----|
| Distance r_{max} [mm] | 25 | 35 | 35 | 50 | 50 | 50 | 50 | 50 |

Linear drives DGC-G

Technical data



Number of profile mountings MUC dependent on force due to weight F and support span l

In order to limit deflection in the case of large strokes, the drive may need to be supported. The following diagrams

serve to determine the maximum permissible support span as a

function of the mounting position and the perpendicular force.

Horizontal mounting position

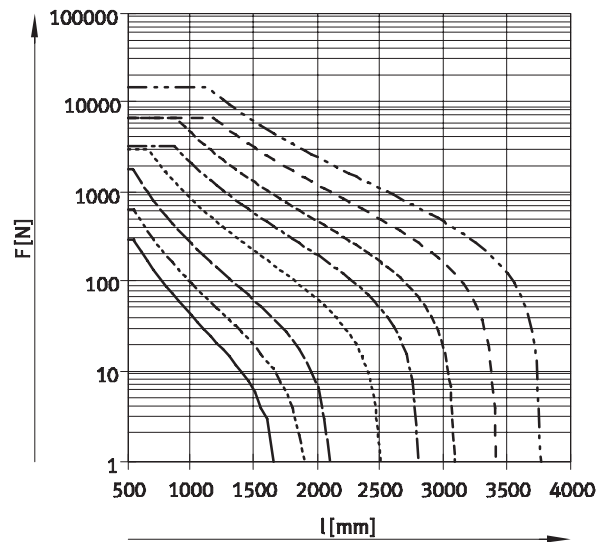
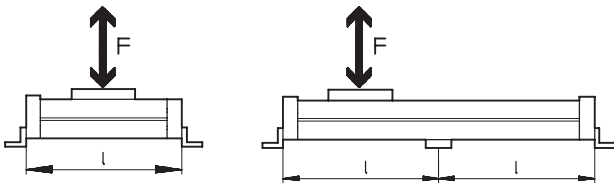

Vertical mounting position

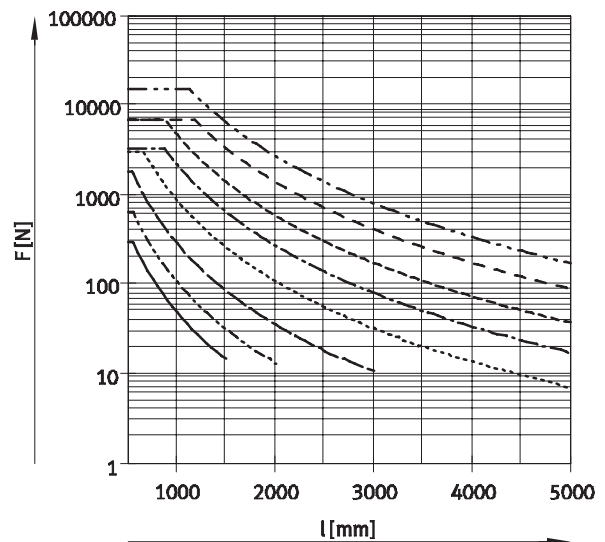
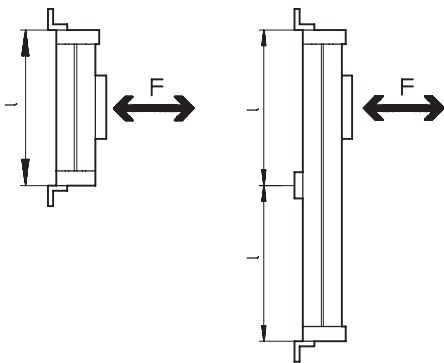

Example:

The drive DGC-25-1500 is subjected to a force of 300 N in horizontal mounting position.

The drive has an overall length of:

$$\begin{aligned}
 l &= \text{stroke length} + L1 \\
 &= 1,500 \text{ mm} + 200 \text{ mm} \\
 &= 1,700 \text{ mm}
 \end{aligned}$$

According to the diagram, the max. support span is 1,300 mm for the drive DGC-25 with a force of 300 N.

In this example, profile mountings are required as the max. support span (1,300 mm) is smaller than the overall length of the drive (1,700 mm).

Linear drives DGC-G

Technical data

Dimensions

Download CAD data → www.festo.com

∅ 8 and 12

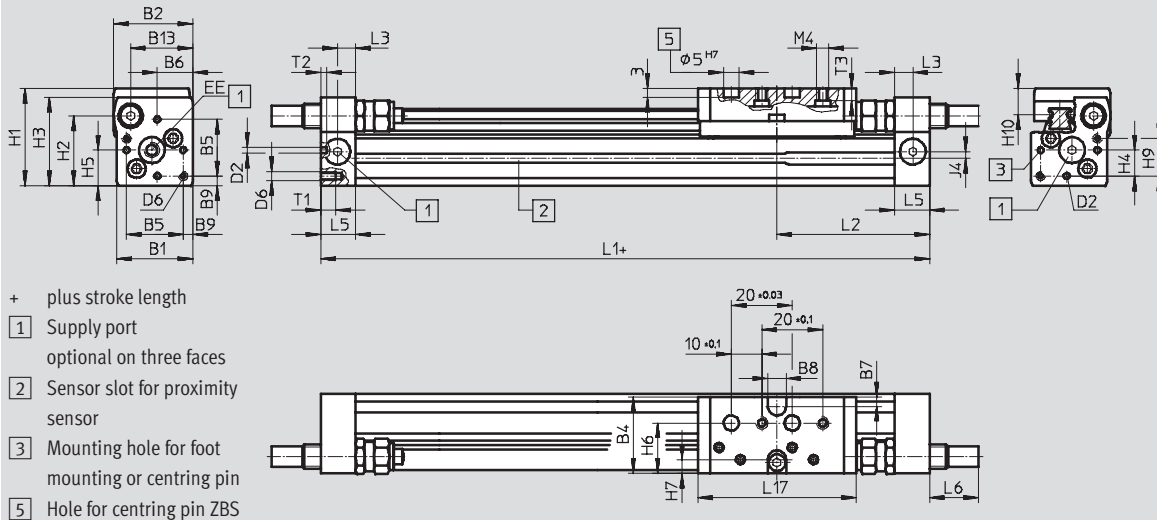

- + plus stroke length
- 1 Supply port
optional on three faces
- 2 Sensor slot for proximity
sensor
- 3 Mounting hole for foot
mounting or centring pin
- 5 Hole for centring pin ZBS

| ∅ | B1 | B2 | B4 | B5 | B6 | B7 | B8 | B9 | B13 | D2 | D6 | EE |
|------|------|----|------|------|------|----|-------|------|------|---------|----|----|
| [mm] | | | | | | | ±0.05 | ±0.1 | | ∅ H8 | | |
| 8 | 25 | 26 | 25.5 | 18.6 | 11.7 | 3 | 6 | 3.2 | 20.5 | 2 | M3 | M5 |
| 12 | 30.2 | 31 | 30.5 | 20.6 | 13.5 | 3 | 8 | 4.8 | 25 | 2 | M4 | M5 |

| ∅ | H1 | H2 | H3 | H4 | H5 | H6 | H7 | H9 | H10 | J4 | L1 | L2 |
|------|------|------|------|-----|------|------|-----|------|-----|-----|---------------|------|
| [mm] | | | | | | | | | | | +0.5/ -0.4 | |
| 8 | 32 | 23 | 29 | 8.5 | 11.7 | 16.5 | 4.5 | 12.3 | 8.7 | 2.2 | 100 | 50.1 |
| 12 | 37.5 | 28.5 | 34.5 | 8.7 | 13.5 | 20.5 | 5 | 14.7 | 9.8 | 3 | 125 | 62.1 |

| ∅ | L3 | L5 | L6 | | | L17 | T1 | T2 | T3 | Stroke tolerance |
|------|----|------|----|------|------|-----|----|----|----|------------------|
| | | | P | YSR | YSRW | | | | | |
| [mm] | | | | | | | | | | |
| 8 | 6 | 11.5 | 0 | 16 | 16.2 | 52 | 5 | 2 | 4 | 0 ... 1.7 |
| 12 | 8 | 16 | 0 | 11.3 | 12.3 | 65 | 6 | 2 | 5 | |

Profile barrel

∅ 8

∅ 12

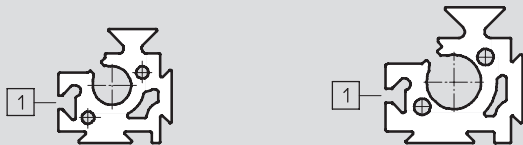

1 Sensor slot for proximity sensor

Linear drives DGC-G

Technical data

FESTO

Dimensions

Download CAD data → www.festo.com

∅ 18 ... 40

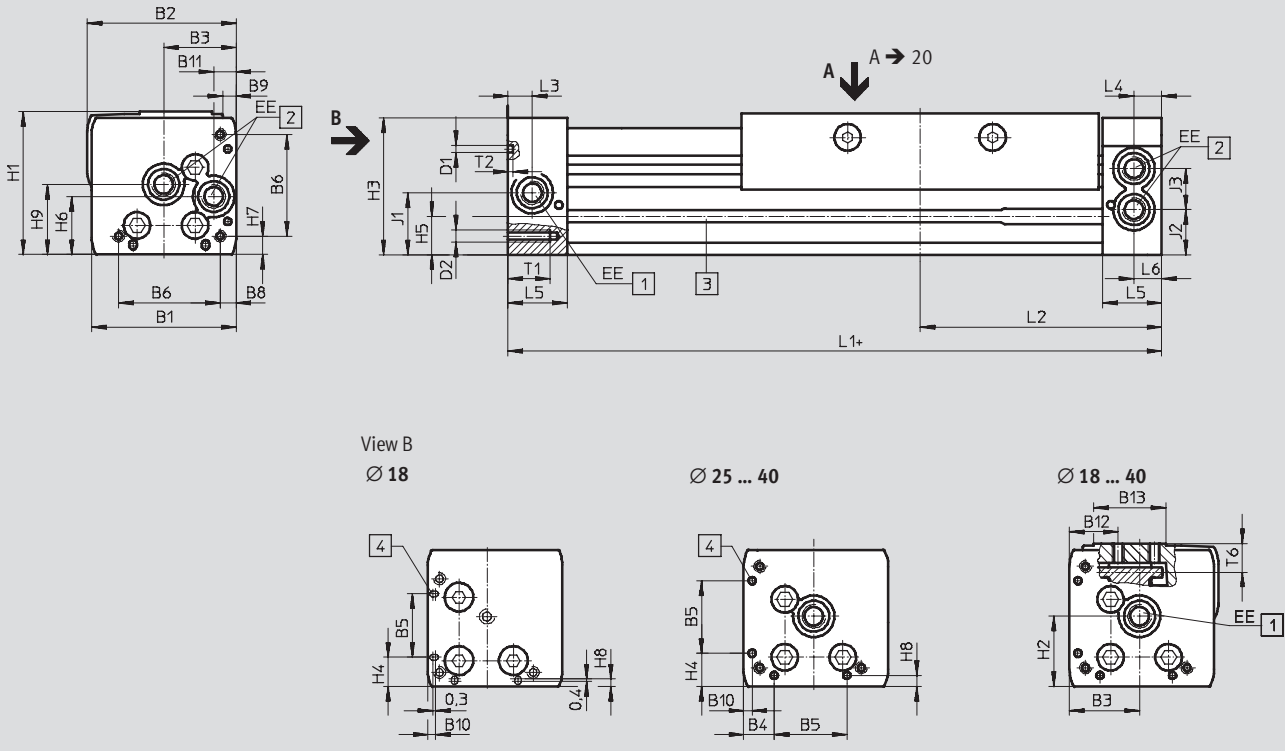

∅ 50/63

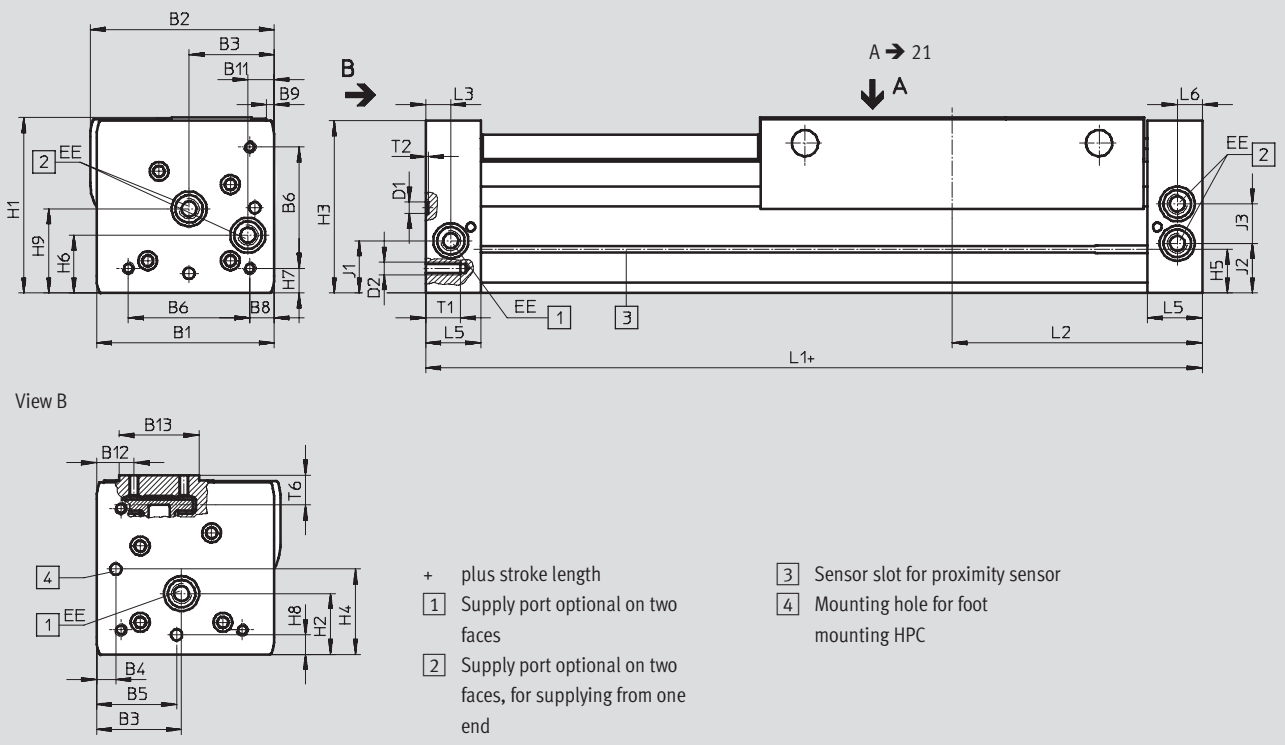

Linear drives DGC-G

Technical data

| ∅ | B1 | B2 | B3 | B4 | B5 | B6 | B8 | B9 |
|------|------|------|------|-------|-------|------|------|-----|
| [mm] | | | | | ±0.05 | | | |
| 18 | 44.5 | 46.3 | 19.5 | 8.8 | 21 | 31 | 3.8 | 3.3 |
| 25 | 59.8 | 61.6 | 30 | 12.65 | 30 | 42 | 6.65 | 5.6 |
| 32 | 73 | 75.5 | 38.5 | 5.7 | 63.1 | 57.5 | 8.5 | 5 |
| 40 | 91 | 94.5 | 45 | 17.2 | 55 | 65 | 12.2 | 5.3 |
| 50 | 113 | 127 | 60 | 8 | 52.8 | 81.6 | 12 | 0 |
| 63 | 142 | 147 | 68 | 15.5 | 68 | 97 | 19.5 | 6 |

| ∅ | B10 | B11 | B12 | B13 | D1 | D2 | EE | H1 | H2 |
|------|-----|------|-------|-----|--------|-----|------|------|------|
| [mm] | | | | | ∅ | | | | |
| 18 | 2.4 | 5.5 | 19.3 | 20 | 2±0.05 | M4 | M5 | 49.8 | 23.1 |
| 25 | 3.5 | 9.3 | 20.15 | 30 | 3±0.05 | M5 | G1/8 | 58.5 | 29 |
| 32 | 14 | 14.9 | 20.5 | 35 | 3±0.05 | M6 | G1/8 | 73 | 30 |
| 40 | 8 | 16.5 | 19.8 | 45 | 4±0.05 | M6 | G1/4 | 88 | 41.5 |
| 50 | - | 21 | 24 | 64 | 9H7 | M8 | G1/4 | 120 | 38.5 |
| 63 | - | 21 | 30 | 64 | 9H7 | M10 | G3/8 | 140 | 48.5 |

| ∅ | H3 | H4 | H5 | H6 | H7 | H8 | H9 | J1 | J2 |
|------|-------|------|------|------|------|------|------|------|------|
| [mm] | | ±0.2 | | | | | | | |
| 18 | 48.3 | 10.3 | 13.4 | 20 | 5.3 | 2.4 | 25.2 | 20 | 16.5 |
| 25 | 56.5 | 13 | 15.8 | 24 | 7 | 4.5 | 29 | 26.1 | 18.6 |
| 32 | 71.5 | 5.7 | 17 | 27.7 | 8.5 | 14 | 35.2 | 30 | 22 |
| 40 | 85 | 17.2 | 25 | 36.5 | 12.2 | 8 | 44 | 35 | 26 |
| 50 | 116 | 52.8 | 29.3 | 36 | 12 | 8 | 53 | 30.5 | 30.5 |
| 63 | 137.5 | 68 | 34.8 | 46 | 19.5 | 15.5 | 67 | 41.5 | 39.5 |

| ∅ | J3 | L1 | L2 | L3 | L4 | L5 | L6 | T1 | T2 | T6 | Stroke tolerance |
|------|------|-----------|-------|------|------|------|------|------|---------------------|-------|------------------|
| [mm] | | +0.9/-0.2 | | | | | | | | | |
| 18 | 11 | 150 | 74.5 | 5.7 | 5.8 | 15 | 5.5 | 9 | 2 | 10.7 | 0 ... 2.5 |
| 25 | 17 | 200 | 100 | 10.5 | 10.6 | 24.5 | 10.6 | 17.5 | 2 | 12 | |
| 32 | 18.5 | 250 | 124.8 | 14.5 | 14.5 | 30.5 | 14.5 | 15 | 2 | 13.8 | |
| 40 | 26 | 300 | 150 | 14.6 | 14.6 | 33.5 | 14.6 | 20 | 3 | 16.8 | |
| 50 | 28 | 350 | 175 | 17 | - | 41 | 17 | 24 | 2.1 ^{+0.2} | 20.75 | |
| 63 | 31.5 | 400 | 200 | 20 | - | 44 | 20 | 27.5 | 2.1 ^{+0.2} | 20.75 | |

· | Note: This product conforms with the ISO 1179-1 standard and the ISO 228-1 standard.

Linear drives DGC-G

Technical data

FESTO

Dimensions

Download CAD data → www.festo.com

Slide – View A

Ø 18

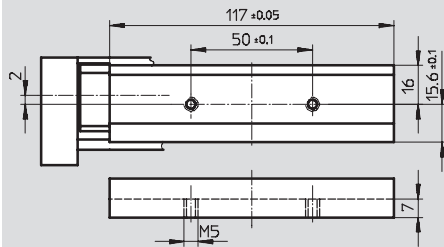

Ø 25

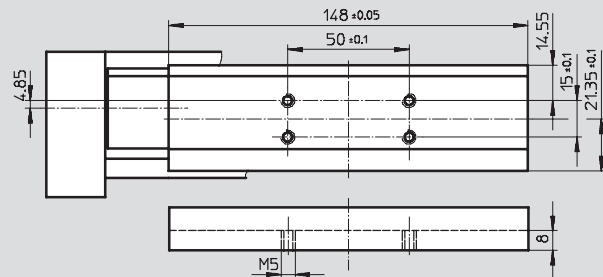

Ø 32

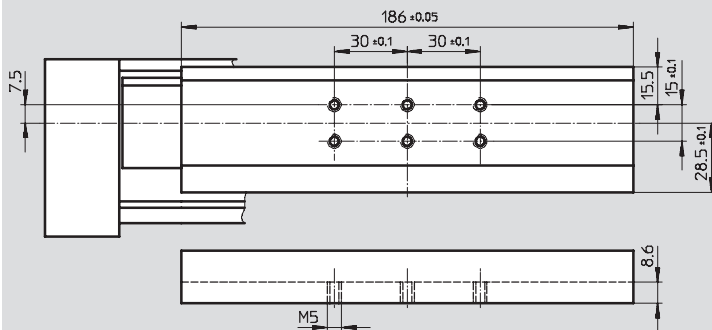

Ø 40

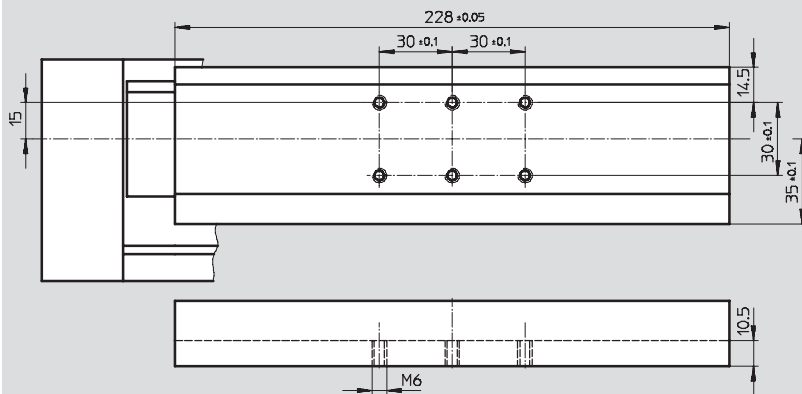

Ø 50

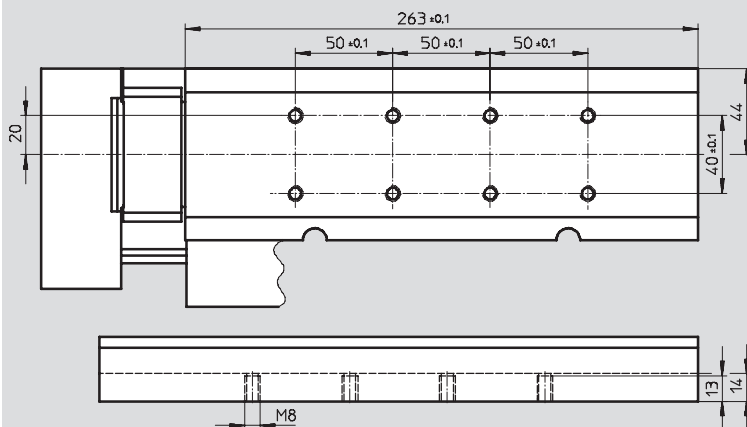

Linear drives DGC-G

Technical data

Dimensions

Download CAD data → www.festo.com

Slide – View A

Ø 63

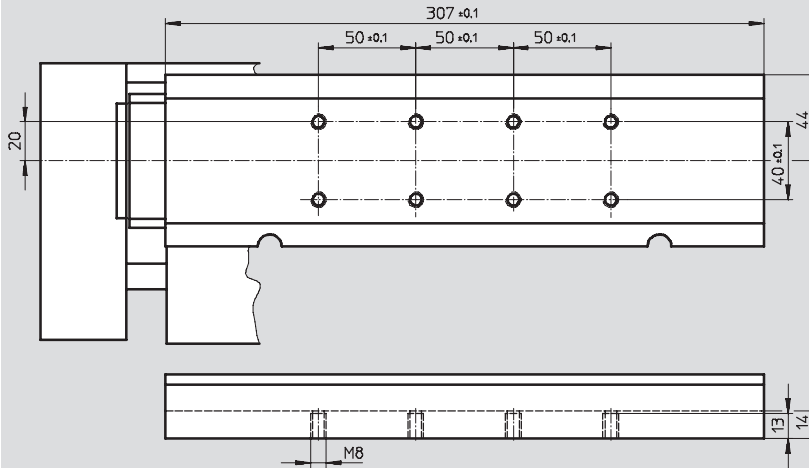

Profile barrel

Ø 18

Ø 25

Ø 32

Ø 40

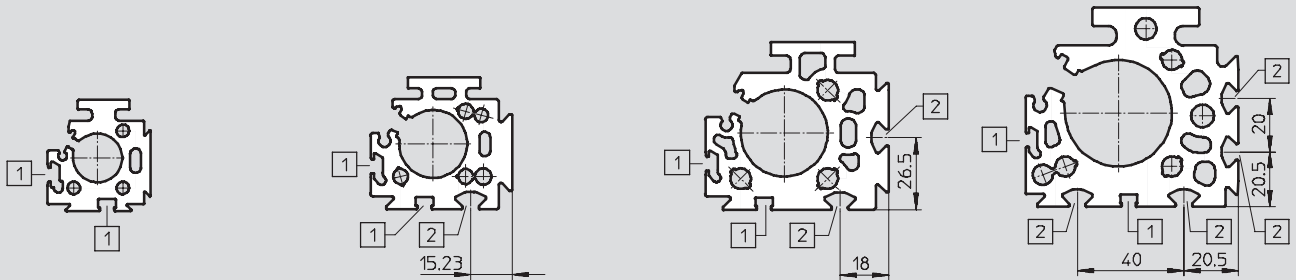

Ø 50

Ø 63

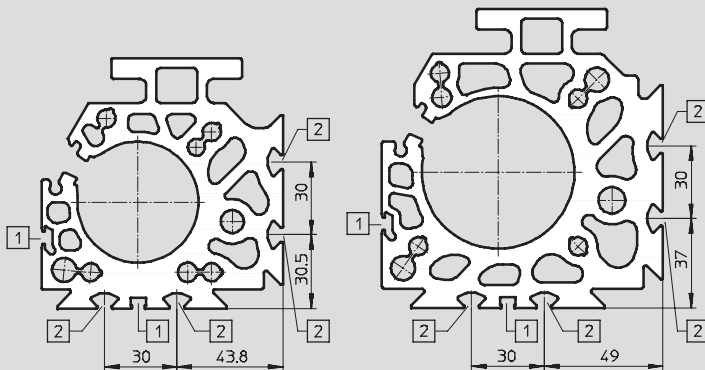

- 1 Sensor slot for proximity sensor
- 2 Mounting slot for slot nut

Linear drives DGC-G

Ordering data – Modular products

Order code

Mandatory data/options

DGC-8/-12

-  - Note
1) End stops or shock absorbers must not be removed.

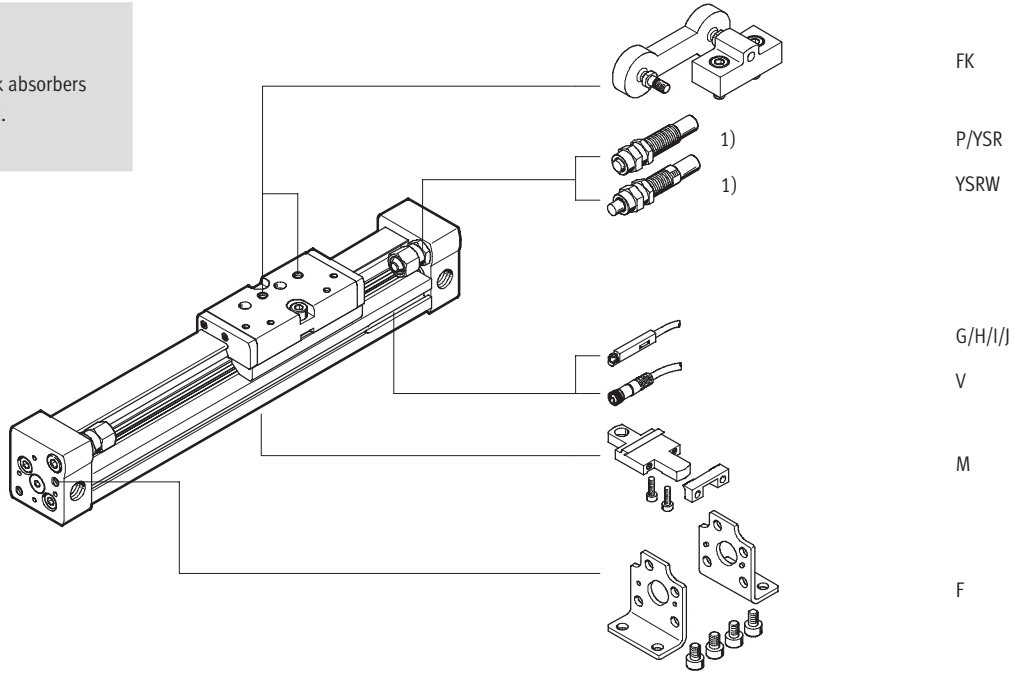

DGC-18 ... 63

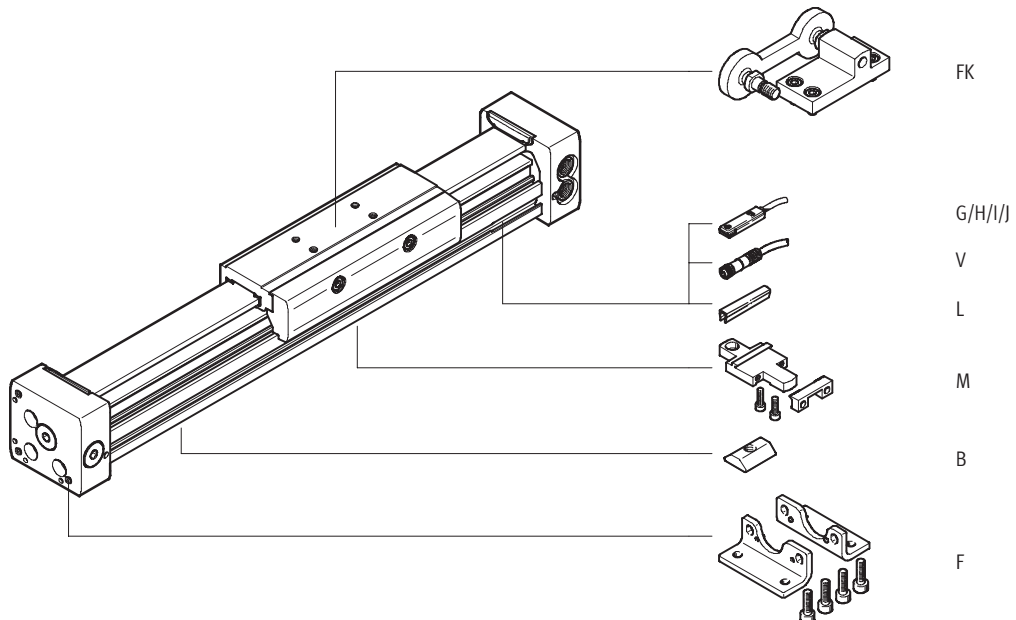

Linear drives DGC-G

Ordering data – Modular products



| M Mandatory data | | | | O Options | | | | |
|----------------------|------------|----------|------------|-----------|------------------|----------|---|-------------|
| Module No. | Function | | Stroke | | Cushioning | | Accessories | |
| | Piston Ø | | Guide | | Position sensing | | Accessories supplied loose | User manual |
| 530 906 | DGC | 8 | 1 ... 8500 | G | P | A | F, ...M, FK, ...B, ...G, ...H, ...I, ...J, ...V, ...L | 0 |
| 530 907 | | 12 | | | PPV | | | |
| 532 446 | | 18 | | | YSR | | | |
| 532 447 | | 25 | | | YSRW | | | |
| 532 448 | | 32 | | | | | | |
| 532 449 | | 40 | | | | | | |
| 532 450 | | 50 | | | | | | |
| 532 451 | | 63 | | | | | | |
| Order example | | | | | | | | |
| 530 906 | DGC | 8 | 300 | G | P | A | ZUB | F2M |

| Ordering table | | | | | | | | | | | | |
|------------------------------------|---|----------------------------------|------------|----------------------|---------|---------|------------|---------|-----------------|------|---------------|--|
| Size | 8 | 12 | 18 | 25 | 32 | 40 | 50 | 63 | Condi- tions | Code | Enter code | |
| M Module No. | 530 906 | 530 907 | 532 446 | 532 447 | 532 448 | 532 449 | 532 450 | 532 451 | | | | |
| Function | Linear drive | | | | | | | | | DGC | DGC | |
| Piston Ø [mm] | 8 | 12 | 18 | 25 | 32 | 40 | 50 | 63 | | -... | | |
| Stroke [mm] | 1 ... 1500 | 1 ... 2000 | 1 ... 3000 | 1 ... 8500 | | | 1 ... 5000 | | | -... | | |
| Guide | Basic design | | | | | | | | | -G | -G | |
| Cushioning | At both ends | Flexible cushioning rings/plates | | - | - | - | - | - | | -P | | |
| | Adjustable at both ends | - | - | Pneumatic cushioning | | | | | | -PPV | | |
| | Self-adjusting | Shock absorber | | - | - | - | - | - | - | | -YSR | |
| Shock absorber, progressive | | - | - | - | - | - | - | | -YSRW | | | |
| Position sensing | For proximity sensor | | | | | | | | | -A | -A | |
| O Accessories | Supplied loose (can be retrofitted) | | | | | | | | | ZUB- | ZUB- | |
| Foot mounting | 1 | | | | | | | | | F | | |
| Profile mounting | 1 ... 9 | | | | | | | | | ...M | | |
| Driver | Moment compensator | | | | | | | | | FK | | |
| Slot nut for mounting slot | - | - | - | 1 ... 9 | | | | | | ...B | | |
| Proximity sensor | Cable, 2.5 m | 1 ... 9 | | | | | | | | | ...G | |
| | M8 plug | 1 ... 9 | | | | | | | | | ...H | |
| Proximity sensor, contactless, PNP | Cable, 2.5 m | 1 ... 9 | | | | | | | | | ...I | |
| | M8 plug | 1 ... 9 | | | | | | | | | ...J | |
| Cable with socket | M8, 2.5 m | 1 ... 9 | | | | | | | | | ...V | |
| Slot cover for sensor slot | - | - | 1 ... 9 | | | | | | ...L | | | |
| User manual | Express waiver – no operating instructions to be included (already available) | | | | | | | | | -O | | |

Transfer order code

DGC - - - **G** - - **A** **ZUB** - -

| Ordering data – Wearing parts kits | | | |
|------------------------------------|----------|----------|--|
| Piston Ø | Part No. | Type | |
| 8 | 665 333 | DGC-8-G | |
| 12 | 665 334 | DGC-12-G | |
| 18 | 684 486 | DGC-18 | |
| 25 | 684 487 | DGC-25 | |
| 32 | 684 488 | DGC-32 | |
| 40 | 684 489 | DGC-40 | |
| 50 | 719 825 | DGC-50 | |
| 63 | 719 826 | DGC-63 | |

Linear drives DGC-GF, with plain-bearing guide

Peripherals overview

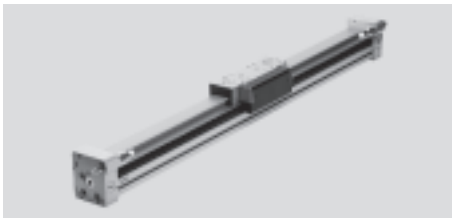

-  - Note
 1) End stops or shock absorbers must not be removed.

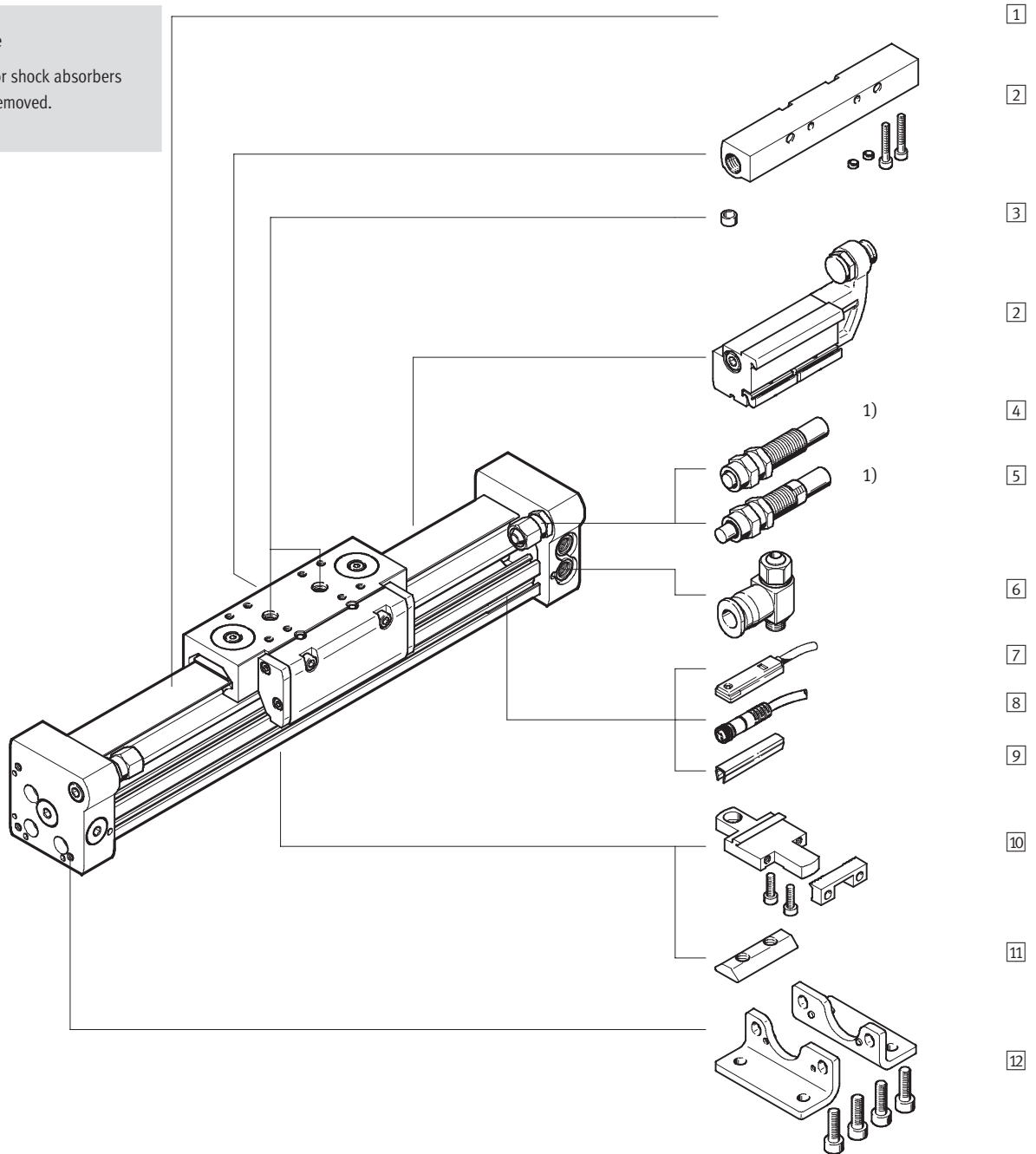

Linear drives DGC-GF, with plain-bearing guide

Peripherals overview

| Variants and accessories | | | |
|---|--------------------------|--|-----------------|
| Type | For piston \varnothing | Brief description | → Page/Internet |
| 1) Linear drive DGC-GF | 18 ... 63 | Linear drive without accessories, plain-bearing guide | 28 |
| 2) Mechanical end position limiter YWZ | 18 ... 63 | For variable end position adjustment, e.g. for format adjustments | 68 |
| 3) Centring pin/sleeve ¹⁾ ZBS/ZBH | 18 ... 63 | For centring loads and attachments on the slide | 72 |
| - Cushioning PPV | 18 ... 63 | Adjustable pneumatic end position cushioning. Used at medium speeds | 39 |
| 4) Shock absorber YSR | 18 ... 63 | Self-adjusting hydraulic shock absorber with spring return and linear cushioning characteristic | 39 |
| 5) Shock absorber YSRW | 18 ... 63 | Self-adjusting hydraulic shock absorber with spring return and progressive cushioning characteristic | 39 |
| 6) One-way flow control valve GRLA | 18 ... 63 | For regulating speed | 72 |
| 7) Proximity sensor G/H/I/J | 18 ... 63 | For sensing the slide position | 73 |
| 8) Cable with socket V | 18 ... 63 | For proximity sensor | 73 |
| 9) Slot cover L | 18 ... 63 | For protecting against ingress of dirt and securing proximity sensor cables | 72 |
| 10) Profile mounting M | 18 ... 63 | Simple and precise mounting option via dovetail connection | 64 |
| 11) Slot nut B | 25 ... 63 | For mounting attachments | 72 |
| 12) Foot mounting F | 18 ... 63 | For mounting on end cap | 60 |

1) Included in the scope of delivery of the drive

Linear drives DGC-GF, with plain-bearing guide

Type codes

DGC – 25 – 1000 – GF – YSR – A

Type

| | |
|-----|--------------|
| DGC | Linear drive |
|-----|--------------|

Piston Ø [mm]

Stroke [mm]

Guide

| | |
|----|---------------------|
| GF | Plain-bearing guide |
|----|---------------------|

Cushioning

| | |
|------|---|
| PPV | Adjustable end position cushioning |
| YSR | Linear shock absorber, self-adjusting |
| YSRW | Shock absorber, progressive, self-adjusting |

Position sensing

| | |
|---|----------------------|
| A | For proximity sensor |
|---|----------------------|

Linear drives DGC-GF, with plain-bearing guide

Type codes

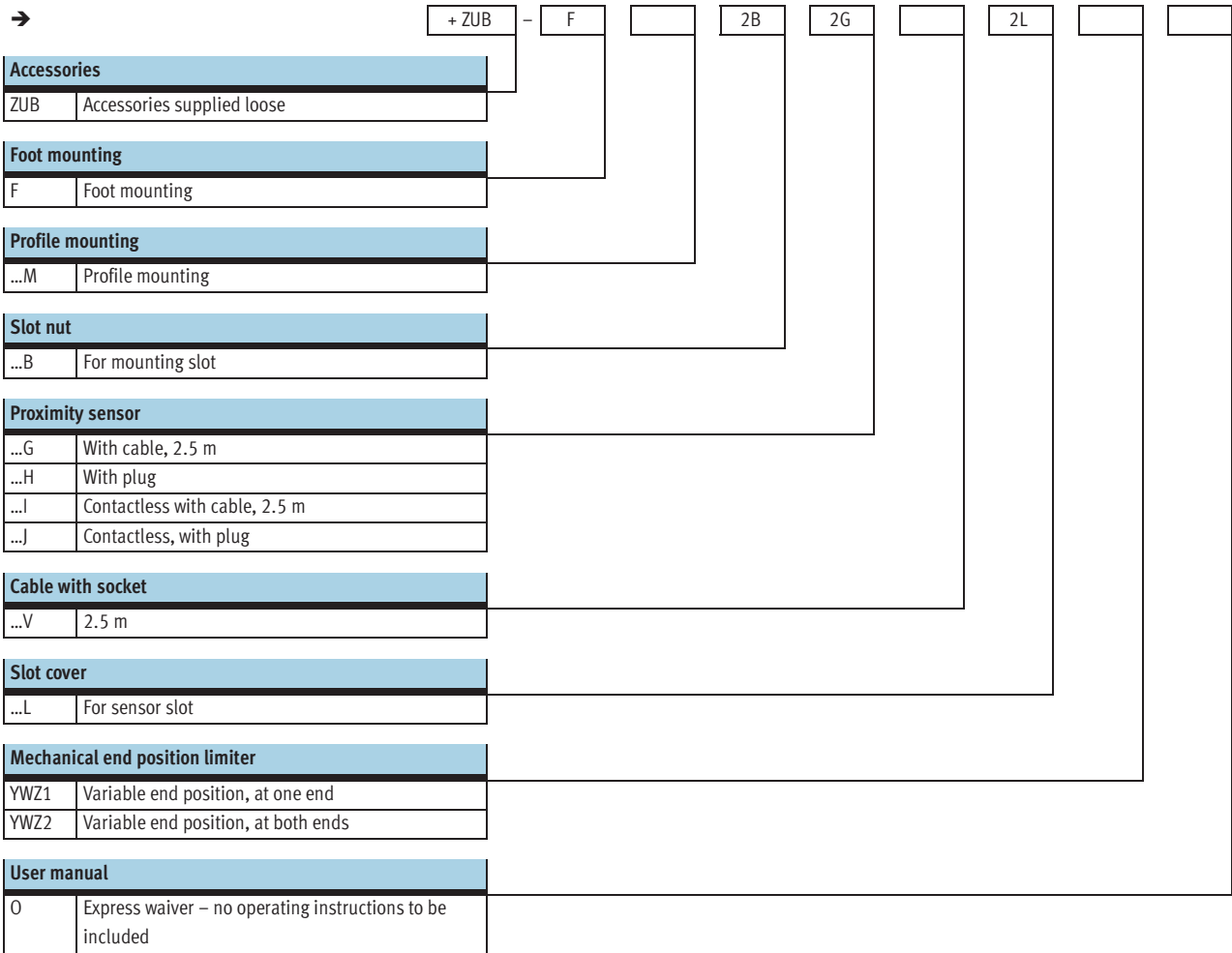

Linear drives DGC-GF, with plain-bearing guide

FESTO

Technical data

Function



www.festo.com

Wearing parts kits
→ 39

∅ - Diameter
18 ... 63 mm

— - Stroke length
1 ... 8,500 mm

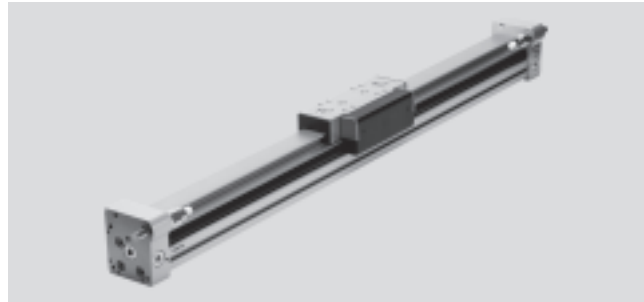

| General technical data | | | | | | | |
|---------------------------------------|--------|--|-----------------|------|-----------------|------|-----------------|
| Piston ∅ | | 18 | 25 | 32 | 40 | 50 | 63 |
| Stroke | [mm] | 1 ... 3,000 | | | 1 ... 8,500 | | 1 ... 5,000 |
| Pneumatic connection | | M5 | G $\frac{1}{8}$ | | G $\frac{1}{4}$ | | G $\frac{3}{8}$ |
| Mode of operation | | Double-acting | | | | | |
| Design | | Rodless drive | | | | | |
| Driver principle | | Slotted cylinder, mechanically coupled | | | | | |
| Guide | | Plain-bearing guide | | | | | |
| Mounting position | | Any | | | | | |
| Cushioning | PPV | Adjustable at both ends | | | | | |
| → 31 | YSR... | Self-adjusting at both ends | | | | | |
| Cushioning length with PPV cushioning | [mm] | 16.5 | 15.5 | 17.5 | 29.5 | 29.8 | 31.1 |
| Position sensing | | For proximity sensor | | | | | |
| Type of mounting | | Profile mounting | | | | | |
| | | Foot mounting | | | | | |
| | | Direct mounting | | | | | |
| Max. speed | [m/s] | 3 | | | | | |

— Note: This product conforms with the ISO 1179-1 standard and the ISO 228-1 standard.

| Operating and environmental conditions | | | | | | | |
|--|-------|---|----|----|-----------|----|----|
| Piston ∅ | | 18 | 25 | 32 | 40 | 50 | 63 |
| Operating pressure | [bar] | 2 ... 8 | | | 1.5 ... 8 | | |
| Operating medium | | Filtered compressed air, lubricated or unlubricated | | | | | |
| Ambient temperature ¹⁾ | [°C] | -10 ... +60 | | | | | |
| Corrosion resistance class CRC ²⁾ | | 2 | | | | | |
| Certification | | C-Tick | | | | | |

1) Note operating range of proximity sensors

2) Corrosion resistance class 2 to Festo standard 940 070

Components subject to moderate corrosion stress. Externally visible parts with primarily decorative surface requirements which are in direct contact with a normal industrial environment or media such as coolants or lubricating agents

| Forces [N] and impact energy [J] | | | | | | | |
|----------------------------------|--|------|-----|-----|-----|-------|-------|
| Piston ∅ | | 18 | 25 | 32 | 40 | 50 | 63 |
| Theoretical force at 6 bar | | 153 | 295 | 483 | 754 | 1,178 | 1,870 |
| Impact energy at end positions | | → 31 | | | | | |

| Weights [g] | | | | | | | |
|------------------------------------|--|-----|-------|-------|-------|--------|--------|
| Piston ∅ | | 18 | 25 | 32 | 40 | 50 | 63 |
| Basic weight with 0 mm stroke | | 763 | 1,609 | 2,532 | 5,252 | 10,065 | 16,308 |
| Additional weight per 10 mm stroke | | 23 | 35 | 55 | 76 | 117 | 180 |
| Moving load | | 267 | 526 | 824 | 1,725 | 3,319 | 5,226 |

Linear drives DGC-GF, with plain-bearing guide

Technical data

FESTO

Adjustable end position range d [mm]

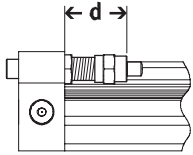

-  - Note

The permissible kinetic energy decreases if the stroke is reduced

with PPV adjustable cushioning at both ends.

| Piston \varnothing | 18 | 25 | 32 | 40 | 50 | 63 |
|----------------------|---------------|---------------|---------------|---------------|---------------|---------------|
| Cushioning PPV | 13.8 ... 15.8 | 21.1 ... 25.1 | 25.2 ... 30.2 | 28.7 ... 33.7 | 28.7 ... 33.7 | 38.8 ... 43.8 |
| Cushioning YSR/YSRW | 14.5 ... 24.5 | 22.5 ... 32.5 | 27.3 ... 37.3 | 31 ... 41 | 31 ... 56 | 41 ... 76 |

Materials

Sectional view

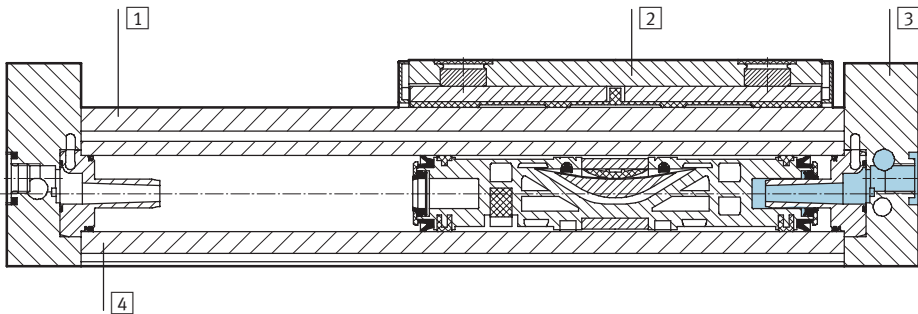

Linear drives

| | | |
|---|--------------------------|--------------------|
| 1 | Guide rail | Anodised aluminium |
| 2 | Slide | Anodised aluminium |
| 3 | End cap | Anodised aluminium |
| 4 | Cylinder barrel | Anodised aluminium |
| - | Piston seal | Polyurethane |
| - | Sealing band/cover strip | Polyurethane |
| - | Slide elements | Polyacetate |

Influence of ferritic materials on proximity sensors

Ferritic materials (steel parts or panels) directly next to the proximity sensors can cause sensing

malfunctions. The following safety distances must be observed.

The distance depends on the position of the proximity sensor (see 1 and 2).

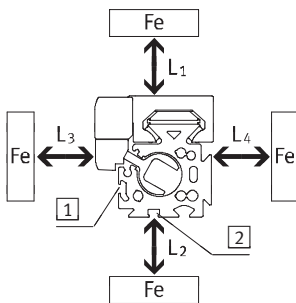

| Piston \varnothing | | | 8 | 12 | 18 | 25 | 32 | 40 | 50 | 63 |
|----------------------|---|------|----|----|----|----|----|----|----|----|
| Distance L1 | 1 | [mm] | 0 | 0 | 0 | 0 | 0 | 0 | 0 | 0 |
| | 2 | [mm] | - | - | 0 | 0 | 0 | 0 | 0 | 0 |
| Distance L2 | 1 | [mm] | 20 | 10 | 10 | 10 | 0 | 0 | 0 | 0 |
| | 2 | [mm] | - | - | 25 | 25 | 25 | 25 | 25 | 25 |
| Distance L3 | 1 | [mm] | 30 | 25 | 25 | 25 | 25 | 25 | 25 | 25 |
| | 2 | [mm] | - | - | 10 | 10 | 0 | 0 | 0 | 0 |
| Distance L4 | 1 | [mm] | 0 | 0 | 0 | 0 | 0 | 0 | 0 | 0 |
| | 2 | [mm] | - | - | 0 | 0 | 0 | 0 | 0 | 0 |

Linear drives DGC-GF, with plain-bearing guide

Technical data

Characteristic load values

The indicated forces and torques refer to the centre of the slide surface.

They must not be exceeded in the dynamic range. Special attention must be paid to the cushioning phase.

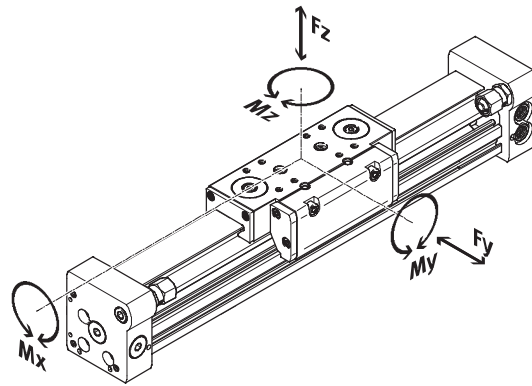

-  - Note

In order to avoid frictional restraint of the guide in the case of the drive DGC-GF with plain-bearing guide when used in vertical mode and with a high torque load, the variant with the recirculating ball bearing guide DGC-KF → 40 is recommended.

If the drive is subjected to more than two of the indicated forces and torques simultaneously, the following equation must be satisfied in addition to the indicated maximum loads:

$$\frac{F_y}{F_{y_{max}}} + \frac{F_z}{F_{z_{max}}} + \frac{M_x}{M_{x_{max}}} + \frac{M_y}{M_{y_{max}}} + \frac{M_z}{M_{z_{max}}} \leq 1$$

| Permissible forces and torques referred to a speed of travel of 0.2 m/s | | | | | | | |
|---|------|-----|-------|-------|-------|-------|-------|
| Piston Ø | | 18 | 25 | 32 | 40 | 50 | 63 |
| F _y _{max.} | [N] | 440 | 640 | 900 | 1,380 | 1,500 | 2,300 |
| F _z _{max.} | [N] | 540 | 1,300 | 1,800 | 2,000 | 2,870 | 4,460 |
| M _x _{max.} | [Nm] | 3.4 | 8.5 | 15 | 28 | 54 | 96 |
| M _y _{max.} | [Nm] | 20 | 40 | 70 | 110 | 270 | 450 |
| M _z _{max.} | [Nm] | 8.5 | 20 | 33 | 54 | 103 | 187 |

-  - Note

Sizing software

ProDrive

→ www.festo.com

Linear drives DGC-GF, with plain-bearing guide

Technical data

Maximum permissible piston speed v as a function of effective load m

With PPV cushioning

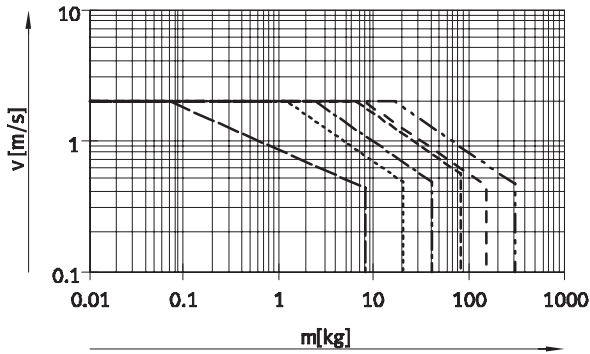

With YSR cushioning

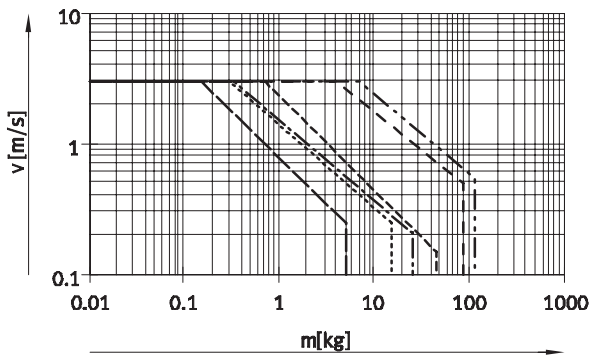

With YSRW cushioning

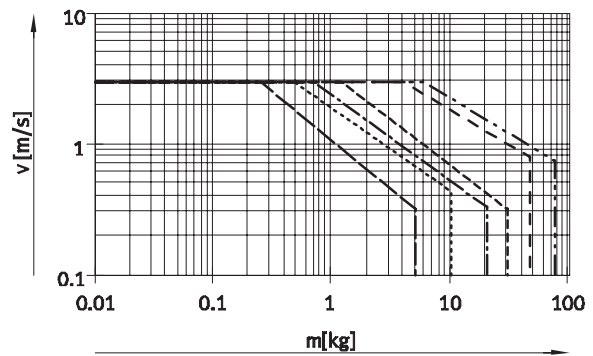

- Ø 18
- - - - - Ø 25
- · - · - Ø 32
- - - - - Ø 40
- - - - - Ø 50
- · - · - Ø 63

Note

This data represents the maximum values that can be achieved. Values fluctuate in practice relative to the position of the effective load and mounting position.

Operating range of cushioning

The end position cushioning must be adjusted to ensure jerk-free operation. If the operating conditions are outside the permissible range, the

load to be moved must be cushioned using suitable equipment (external shock absorbers), preferably at the centre of gravity of the mass.

Note

To avoid distortion in the slide, the bearing surfaces of the attachments must maintain a flatness of at least 0.03 mm.

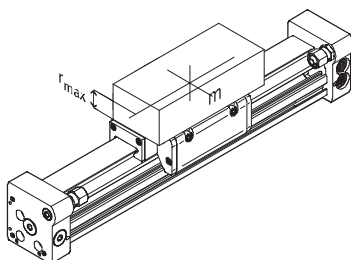

| Piston Ø | 8 | 12 | 18 | 25 | 32 | 40 | 50 | 63 |
|-------------------------|----|----|----|----|----|----|----|----|
| Distance r_{max} [mm] | 25 | 35 | 35 | 50 | 50 | 50 | 50 | 50 |

Linear drives DGC-GF, with plain-bearing guide

Technical data

FESTO

Number of profile mountings MUC dependent on force due to weight F and support span l

In order to limit deflection in the case of large strokes, the drive may need to be supported. The following diagrams

serve to determine the maximum permissible support span as a

function of the mounting position and the perpendicular force.

Horizontal mounting position

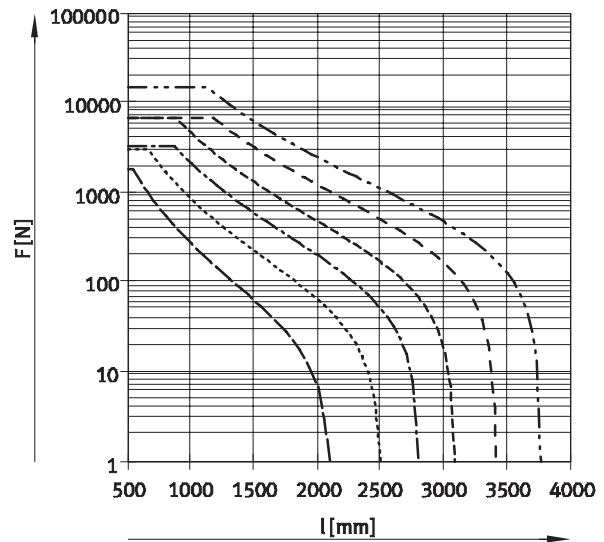
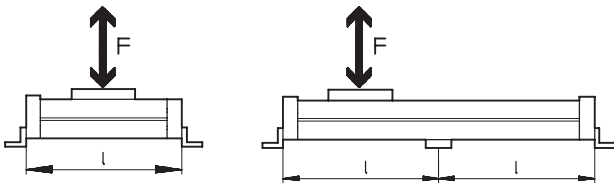

Vertical mounting position

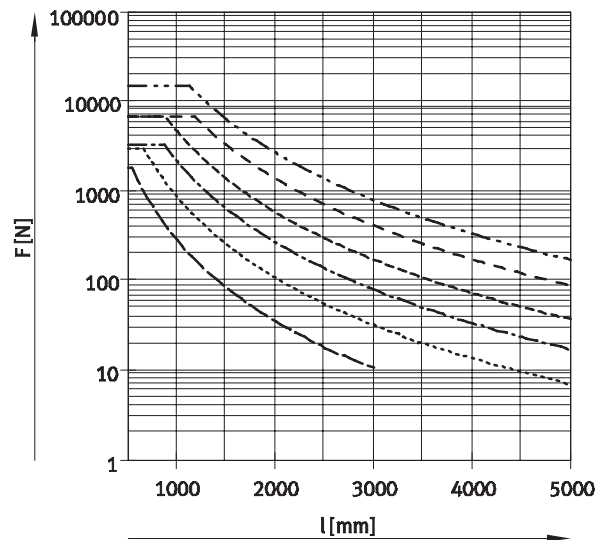
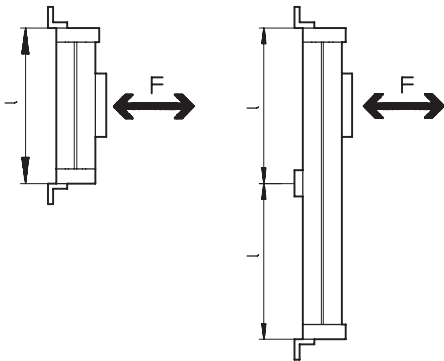

| | | | |
|-----------|------|---------|------|
| — | ∅ 18 | - - - - | ∅ 40 |
| - · - · - | ∅ 25 | - - - - | ∅ 50 |
| - · - · - | ∅ 32 | - - - - | ∅ 63 |

Example:

The drive DGC-25-1500 is subjected to a force of 300 N in horizontal mounting position.

The drive has an overall length of:
 $l = \text{stroke length} + L1$
 (see dimensions)
 $= 1,500 \text{ mm} + 200 \text{ mm}$
 $= 1,700 \text{ mm}$

According to the diagram, the max. support span is 1,300 mm for the drive DGC-25 with a force of 300 N.

In this example, profile mountings are required as the max. support span (1,300 mm) is smaller than the overall length of the drive (1,700 mm).

Linear drives DGC-GF, with plain-bearing guide

Technical data

FESTO

Dimensions Download CAD data → www.festo.com

∅ 18 ... 40

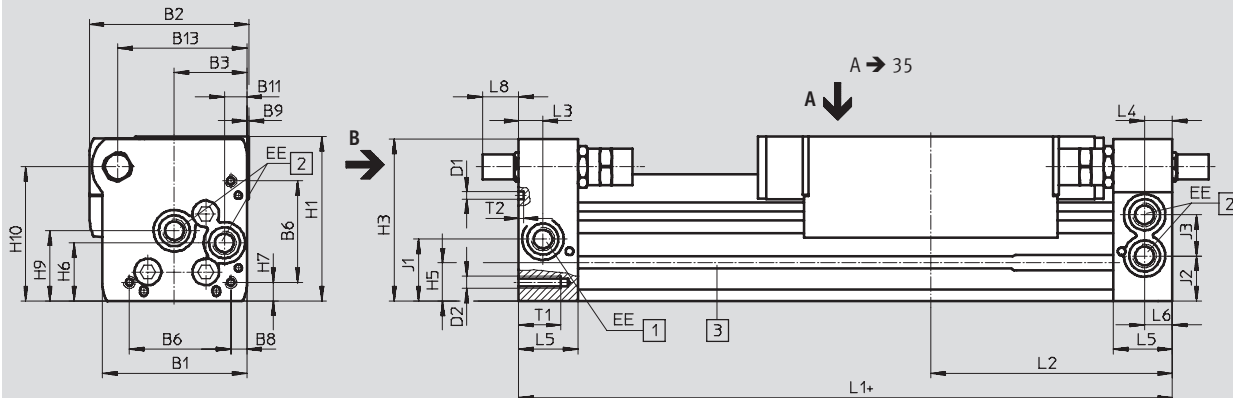

View B
∅ 18

∅ 25 ... 40

∅ 18 ... 40

- + plus stroke length
- 1 Supply port optional on two faces
- 2 Supply port optional on two faces, for supplying from one end
- 3 Sensor slot for proximity sensor
- 4 Mounting hole for foot mounting HPC

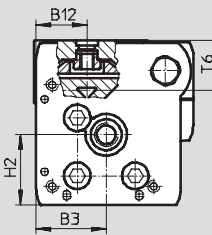
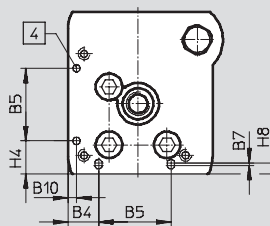
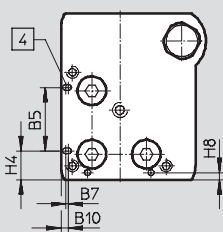

| ∅ | B1 | B2 | B3 | B4 | B5 | B6 | B7 | B8 | B9 | B10 | B11 | B12 | B13 | D1 |
|------|------|------|------|-------|-------|------|-----|------|-----|-----|------|------|------|-------|
| [mm] | | | | | ±0.05 | | | | | | | | | ±0.05 |
| 18 | 44.5 | 49.9 | 19.5 | 8.8 | 21 | 31 | 0.8 | 3.8 | 1 | 2.4 | 5.5 | 15.5 | 39 | 2 |
| 25 | 59.8 | 66 | 30 | 12.65 | 30 | 42 | 1 | 6.65 | 1 | 3.5 | 9.3 | 21 | 53.5 | 3 |
| 32 | 73 | 79 | 38.5 | 5.7 | 63.1 | 57.5 | - | 8.5 | 1.5 | 14 | 14.9 | 18 | 66.5 | 3 |
| 40 | 91 | 98.5 | 45 | 17.2 | 55 | 65 | - | 12.2 | 2 | 8 | 16.5 | 24.8 | 80.5 | 4 |

| ∅ | D2 | EE | H1 | H2 | H3 | H4 | H5 | H6 | H7 | H8 | H9 | H10 | J1 | J2 |
|------|----|------|------|------|------|-------|------|------|------|-----|------|------|------|------|
| [mm] | | | | | | ±0.2 | | | | | | | | |
| 18 | M4 | M5 | 56.3 | 23.1 | 55 | 9.6 | 13.4 | 20 | 4.6 | 2.4 | 25.2 | 46 | 20 | 16.5 |
| 25 | M5 | G1/8 | 68 | 29 | 67 | 13.65 | 15.8 | 24 | 7.65 | 4.5 | 29 | 55.5 | 26.1 | 18.6 |
| 32 | M6 | G1/8 | 78.5 | 30 | 77 | 5.7 | 17 | 27.7 | 8.5 | 14 | 35.2 | 63.8 | 30 | 22 |
| 40 | M6 | G1/4 | 99.5 | 41.5 | 97.5 | 17.2 | 25 | 36.5 | 12.2 | 8 | 44 | 81.5 | 35 | 26 |

| ∅ | J3 | L1 | L2 | L3 | L4 | L5 | L6 | L8 | | | T1 | T2 | T6 | Stroke tolerance |
|------|------|-----------|-------|------|------|------|------|-----|------|------|------|----|------|------------------|
| [mm] | | +0.9/-0.2 | | | | | | PPV | YSR | YSRW | | | | |
| 18 | 11 | 150 | 74.5 | 5.7 | 5.8 | 15 | 5.5 | 0 | 15.9 | 19.4 | 9 | 2 | 17.1 | 0 ... 2.5 |
| 25 | 17 | 200 | 100 | 10.5 | 10.6 | 24.5 | 10.6 | 0 | 12.5 | 15 | 17.5 | 2 | 20.5 | |
| 32 | 18.5 | 250 | 124.8 | 14.5 | 14.5 | 30.5 | 14.5 | 0 | 8.5 | 15.5 | 15 | 2 | 21.3 | |
| 40 | 26 | 300 | 150 | 14.6 | 14.6 | 33.5 | 14.6 | 0 | 12.8 | 21 | 20 | 3 | 30.7 | |

Note: This product conforms with the ISO 1179-1 standard and the ISO 228-1 standard.

Linear drives DGC-GF, with plain-bearing guide

Technical data

Dimensions Download CAD data → www.festo.com

Ø 50/63

View B

- + plus stroke length
- 1 Supply port optional on two faces
- 2 Supply port optional on two faces, for supplying from one end
- 3 Sensor slot for proximity sensor
- 4 Mounting hole for foot mounting HPC

| Ø | B1 | B2 | B3 | B4 | B5 | B6 | B8 | B9 | B11 | B12 | B13 | D1 | D2 |
|------|-----|-------|----|------|-------|------|------|----|-----|-----|-------|---------|----|
| [mm] | | | | | ±0.05 | | | | | | | Ø H7 | |
| 50 | 113 | 126.5 | 60 | 8 | 52.8 | 81.6 | 12 | - | 21 | 24 | 97 | 9 | M8 |
| 63 | 142 | 149 | 68 | 15.5 | 68 | 97 | 19.5 | 5 | 21 | 30 | 123.5 | 9 | |

| Ø | EE | H1 | H2 | H3 | H4 | H5 | H6 | H7 | H8 | H9 | H10 | H11 | J1 |
|------|----|-------|------|-------|------|------|----|------|------|----|-------|-------|------|
| [mm] | | | | | | | | | | | | ±0.05 | |
| 50 | G¼ | 124.5 | 38.5 | 122.5 | 52.8 | 29.3 | 36 | 12 | 8 | 53 | 104.5 | 100 | 30.5 |
| 63 | G⅜ | 153.5 | 48.5 | 151 | 68 | 34.8 | 46 | 19.5 | 15.5 | 67 | 131 | 120 | 41.5 |

| Ø | J2 | J3 | L1 | L2 | L3 | L5 | L6 | L8 | | | T1 | T2 | T6 | Stroke tolerance |
|------|------|------|-----------|-----|----|----|----|-----|------|------|------|-----|------|------------------|
| | | | | | | | | PPV | YSR | YSRW | | | | |
| [mm] | | | +0.9/-0.2 | | | | | | | | +0.2 | | | |
| 50 | 30.5 | 28 | 350 | 175 | 17 | 41 | 17 | 0 | 31 | 36.3 | 24 | 2.1 | 30.4 | 0 ... 2.5 |
| 63 | 39.5 | 31.5 | 400 | 200 | 20 | 44 | 20 | 0 | 38.3 | 48.3 | 27.5 | 2.1 | 36.2 | |

- | - Note: This product conforms with the ISO 1179-1 standard and the ISO 228-1 standard.

Linear drives DGC-GF, with plain-bearing guide

Technical data

FESTO

Dimensions

Download CAD data → www.festo.com

Slide

Ø 18

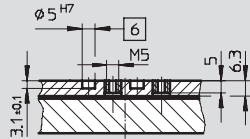

View A

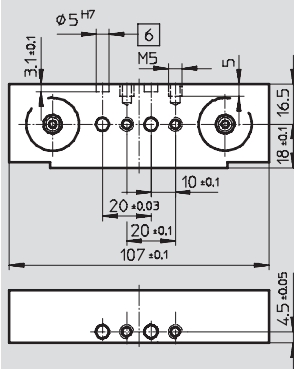

Ø 25

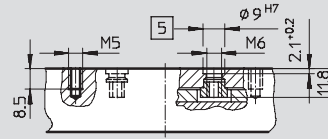

View A

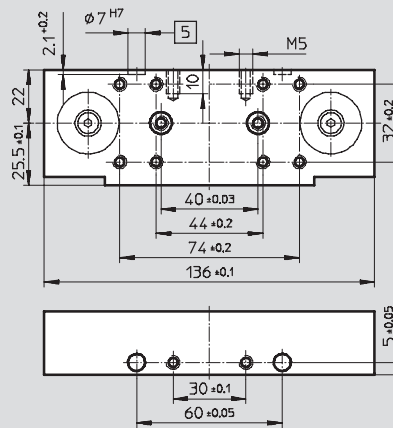

Ø 32

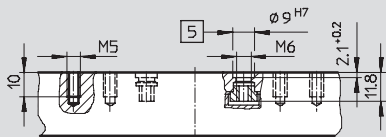

View A

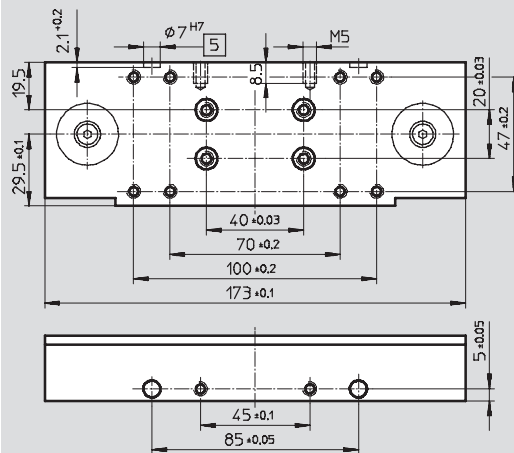

Ø 40

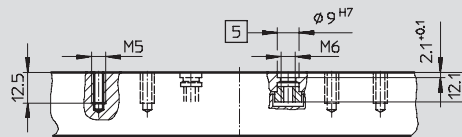

View A

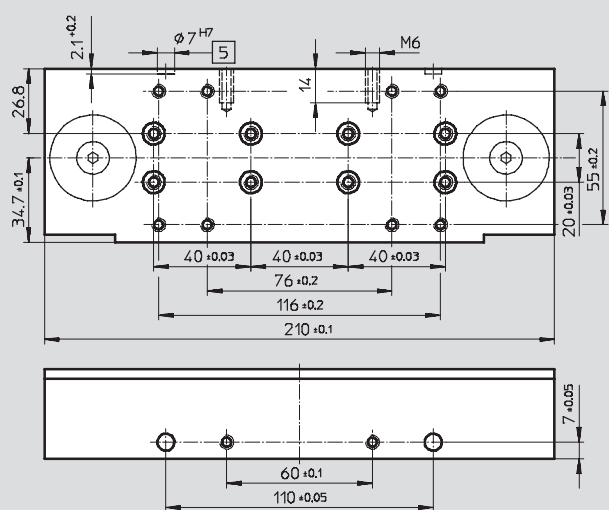

- 5 Hole for centring sleeve ZBH
- 6 Hole for centring pin ZBS

Linear drives DGC-GF, with plain-bearing guide

Technical data

FESTO

Dimensions

Download CAD data → www.festo.com

Slide

Ø 50

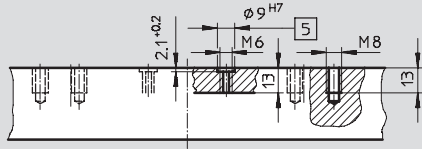

View A

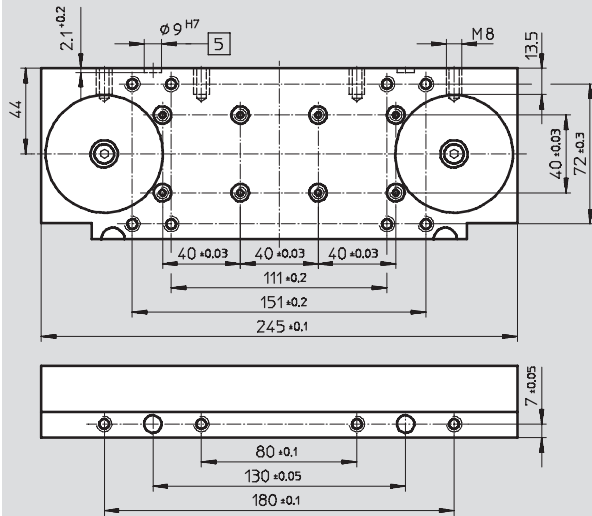

Ø 63

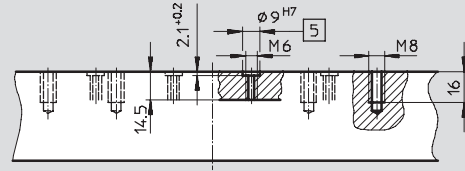

View A

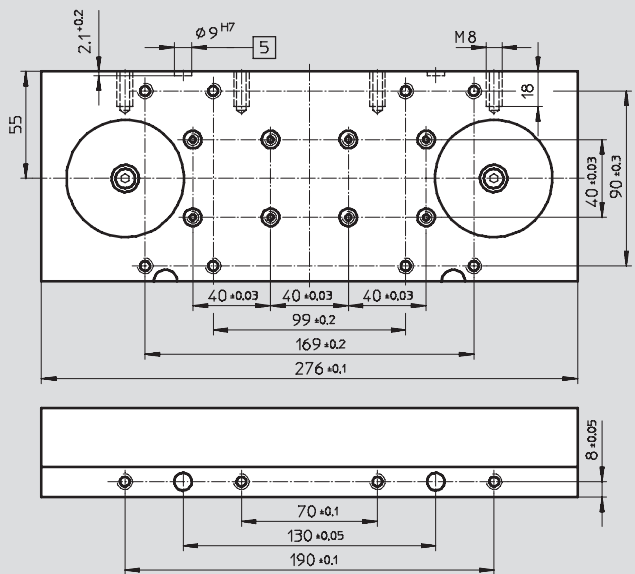

- 5 Hole for centring sleeve ZBH
- 6 Hole for centring pin ZBS

Linear drives DGC-GF, with plain-bearing guide

Technical data

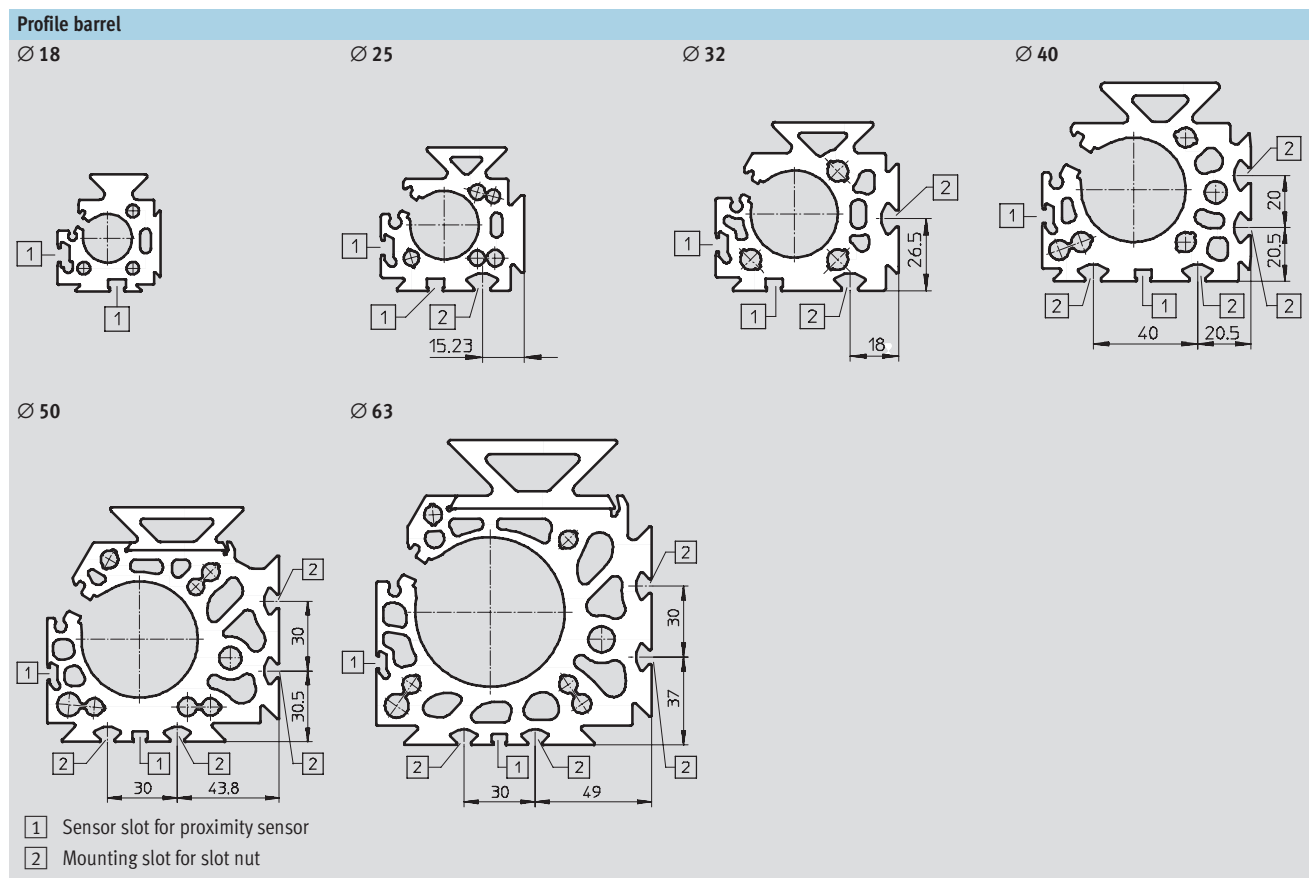

Linear drives DGC-GF, with plain-bearing guide

Ordering data – Modular products

Order code

Mandatory data/options

-  - Note

1) End stops or shock absorbers must not be removed.

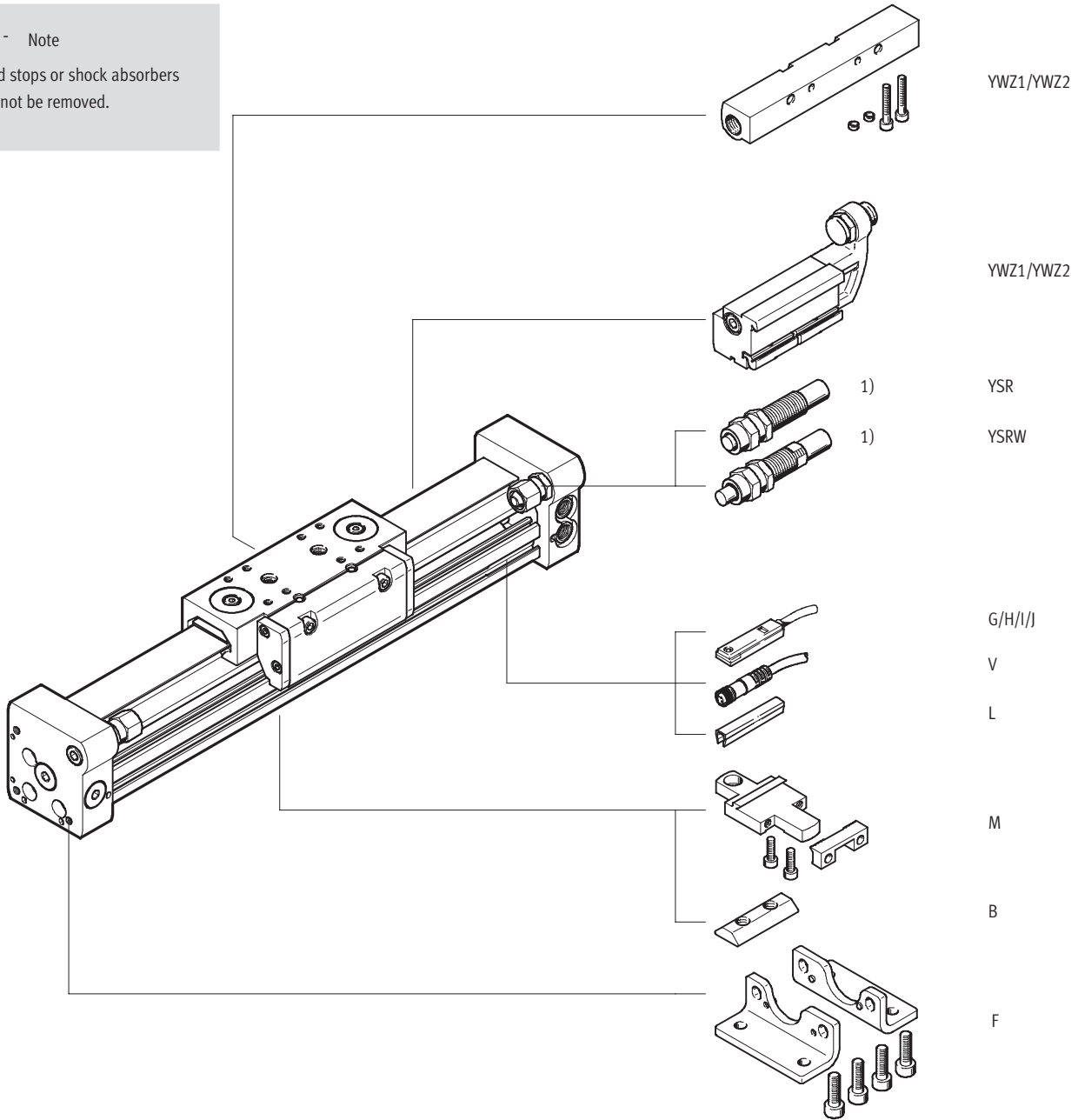

Linear drives DGC-GF, with plain-bearing guide

Ordering data – Modular products

| M Mandatory data | | | | O Options | | | |
|----------------------|----------|---------------|------------------|---|-----------|-------------|--|
| Module No. | Function | Stroke | Cushioning | Accessories | | | |
| | Piston Ø | Guide | Position sensing | Accessories supplied loose | | User manual | |
| 532 446 | DGC 18 | 1 ... 8500 GF | PPV A | F, ...M, ...B, ...G, ...H, ...I, ...J, ...V, ...L, YWZ1, YWZ2 | | 0 | |
| 532 447 | 25 | | YSR | | | | |
| 532 448 | 32 | | YSRW | | | | |
| 532 449 | 40 | | | | | | |
| 532 450 | 50 | | | | | | |
| 532 451 | 63 | | | | | | |
| Order example | | | | ZUB | F2M2I2V | | |
| 532 446 | DGC - 18 | - 250 - GF | - PPV - A | ZUB | - F2M2I2V | | |

| Ordering table | | | | | | | | | | |
|------------------------------------|---|------------|---------|------------|---------|---------|-----------------|------|-------|---------------|
| Size | 18 | 25 | 32 | 40 | 50 | 63 | Condi- tions | Code | | Enter code |
| M Module No. | 532 446 | 532 447 | 532 448 | 532 449 | 532 450 | 532 451 | | | | |
| Function | Linear drive | | | | | | | | DGC | DGC |
| Piston Ø [mm] | 18 | 25 | 32 | 40 | 50 | 63 | | -... | | |
| Stroke [mm] | 1 ... 3000 | 1 ... 8500 | | 1 ... 5000 | | | 1 | -... | | |
| Guide | Plain-bearing guide | | | | | | | | -GF | -GF |
| Cushioning | Pneumatic cushioning, adjustable at both ends | | | | | | | | -PPV | |
| | Shock absorber, self-adjusting | | | | | | | | -YSR | |
| | Shock absorber, self-adjusting, progressive | | | | | | | | -YSRW | |
| Position sensing | For proximity sensor | | | | | | | | -A | -A |
| O Accessories | Supplied loose (can be retrofitted) | | | | | | | | ZUB- | ZUB- |
| Foot mounting | 1 | | | | | | | | F | |
| Profile mounting | 1 ... 9 | | | | | | | | ...M | |
| Slot nut for mounting slot | - 1 ... 9 | | | | | | | | ...B | |
| Proximity sensor | Cable, 2.5 m | 1 ... 9 | | | | | | ...G | | |
| | M8 plug | 1 ... 9 | | | | | | ...H | | |
| Proximity sensor, contactless, PNP | Cable, 2.5 m | 1 ... 9 | | | | | | ...I | | |
| | M8 plug | 1 ... 9 | | | | | | ...J | | |
| Cable with socket | M8, 2.5 m | 1 ... 9 | | | | | | ...V | | |
| Slot cover for sensor slot | 1 ... 9 | | | | | | | | ...L | |
| Mechanical end position limiter | Variable end position, at one end | | | | | | | 1 | YWZ1 | |
| | Variable end position, at both ends | | | | | | | 1 | YWZ2 | |
| User manual | Express waiver – no operating instructions to be included (already available) | | | | | | | | -O | |

1 YWZ1, YWZ2 Only with cushioning YSR or YSRW

Transfer order code

| | | | | | | | | | | | | | | | | | |
|--|-----|---|--|---|--|---|----|---|--|---|---|--|-----|---|--|---|--|
| | DGC | - | | - | | - | GF | - | | - | A | | ZUB | - | | - | |
|--|-----|---|--|---|--|---|----|---|--|---|---|--|-----|---|--|---|--|

| Ordering data – Wearing parts kits | | | | | | | |
|------------------------------------|----------|--------|--|----------|----------|--------|--|
| Piston Ø | Part No. | Type | | Piston Ø | Part No. | Type | |
| 18 | 684 486 | DGC-18 | | 40 | 684 489 | DGC-40 | |
| 25 | 684 487 | DGC-25 | | 50 | 719 825 | DGC-50 | |
| 32 | 684 488 | DGC-32 | | 63 | 719 826 | DGC-63 | |

New
Variants Z1/Z2/Z3 for $\varnothing 40$

Linear drives DGC-KF, with recirculating ball bearing guide

Peripherals overview



 - Note
 1) End stops or shock absorbers must not be removed.

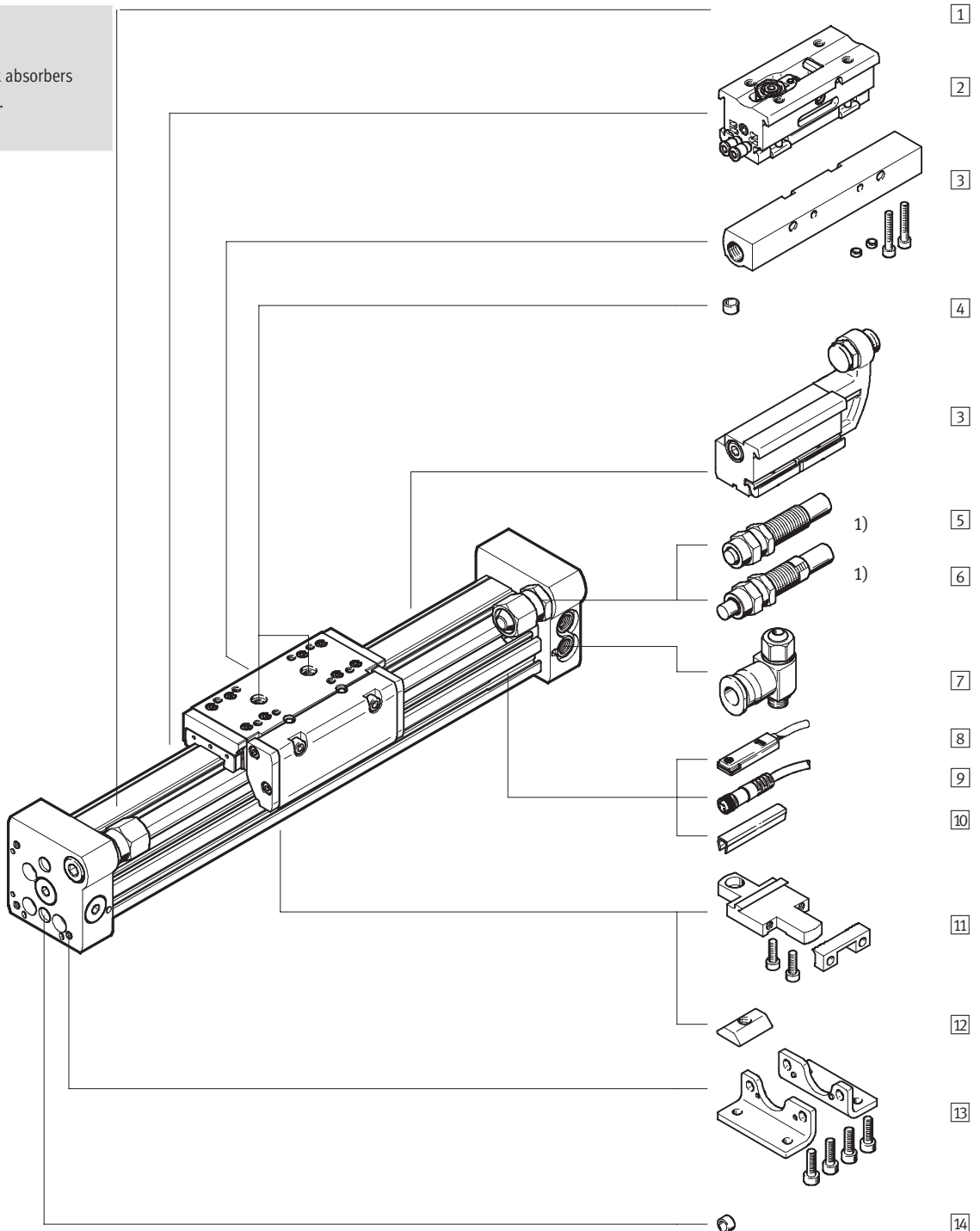

Linear drives DGC-KF, with recirculating ball bearing guide

Peripherals overview

| Variants and accessories | | | |
|---|--------------|--|-----------------|
| Type | For piston Ø | Brief description | → Page/Internet |
| 1 Linear drive DGC-KF | 8 ... 63 | Linear drive without accessories, with recirculating ball bearing guide | 44 |
| 2 Intermediate position module Z1/Z2/Z3 | 25, 32, 40 | Permits up to three intermediate positions | 70 |
| 3 Mechanical end position limiter YWZ | 18 ... 63 | For variable end position adjustment, e.g. for format adjustments | 68 |
| 4 Centring pin/sleeve ¹⁾ ZBS/ZBH | 8 ... 63 | For centring loads and attachments on the slide | 72 |
| – Cushioning P | 8, 12 | Non-adjustable, flexible cushioning. Used only at low speeds | 58 |
| – Cushioning PPV | 18 ... 63 | Adjustable pneumatic end position cushioning. Used at medium speeds | 58 |
| 5 Shock absorber YSR | 8 ... 63 | Self-adjusting hydraulic shock absorber with spring return and linear cushioning characteristic | 58 |
| 6 Shock absorber YSRW | 8 ... 63 | Self-adjusting hydraulic shock absorber with spring return and progressive cushioning characteristic | 58 |
| 7 One-way flow control valve GRLA | 8 ... 63 | For regulating speed | 72 |
| 8 Proximity sensor G/H/I/J | 8 ... 63 | For sensing the slide position | 73 |
| 9 Cable with socket V | 8 ... 63 | For proximity sensor | 73 |
| 10 Slot cover L | 18 ... 63 | For protecting against ingress of dirt and securing proximity sensor cables | 72 |
| 11 Profile mounting M | 8 ... 63 | Simple and precise mounting option via dovetail connection | 64 |
| 12 Slot nut B | 25 ... 63 | For mounting attachments | 72 |
| 13 Foot mounting F | 8 ... 63 | For mounting on end cap | 60 |
| 14 Centring pin/sleeve ¹⁾ ZBS/ZBH | 8 ... 63 | For centring the drive without foot mountings (user-specific) | 72 |

1) Included in the scope of delivery of the drive

Linear drives DGC-KF, with recirculating ball bearing guide

Type codes

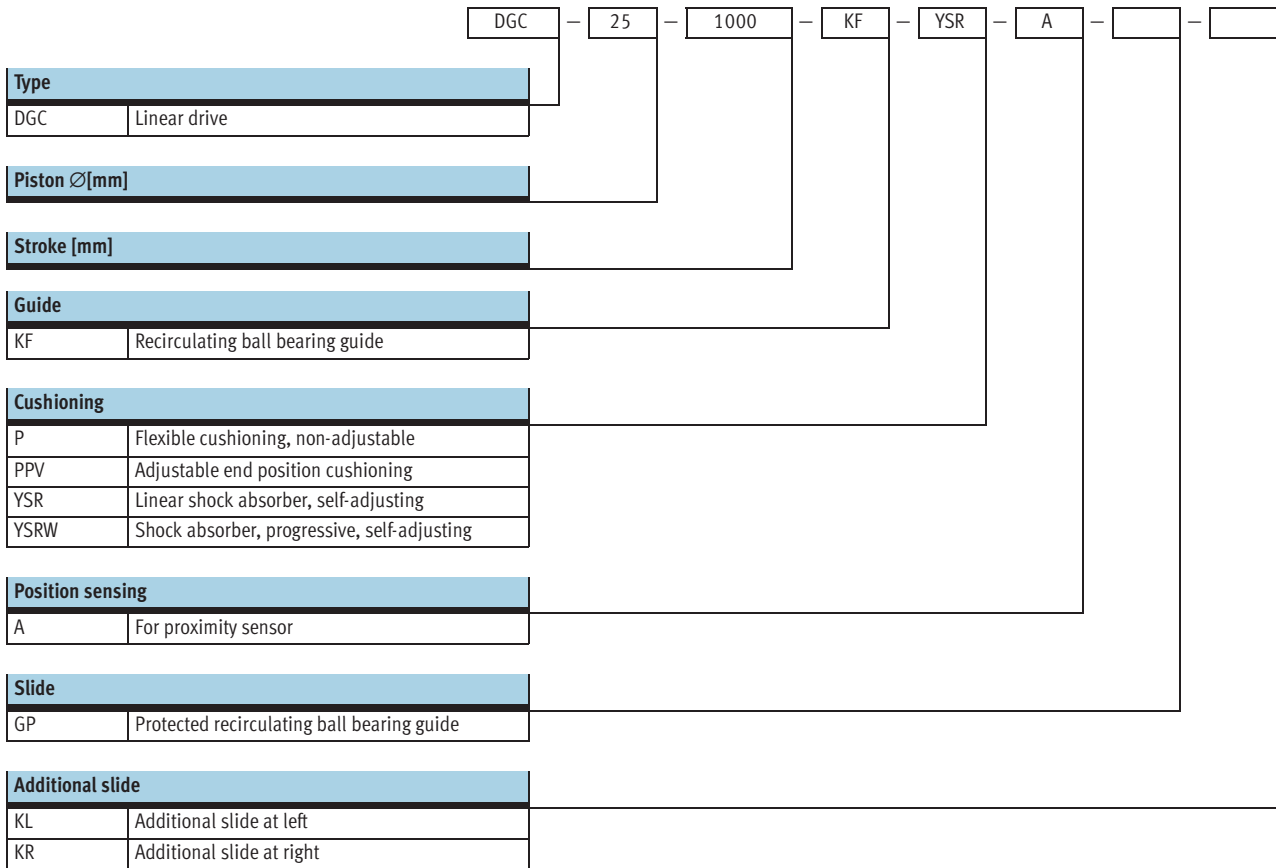

Linear drives DGC-KF, with recirculating ball bearing guide

Type codes

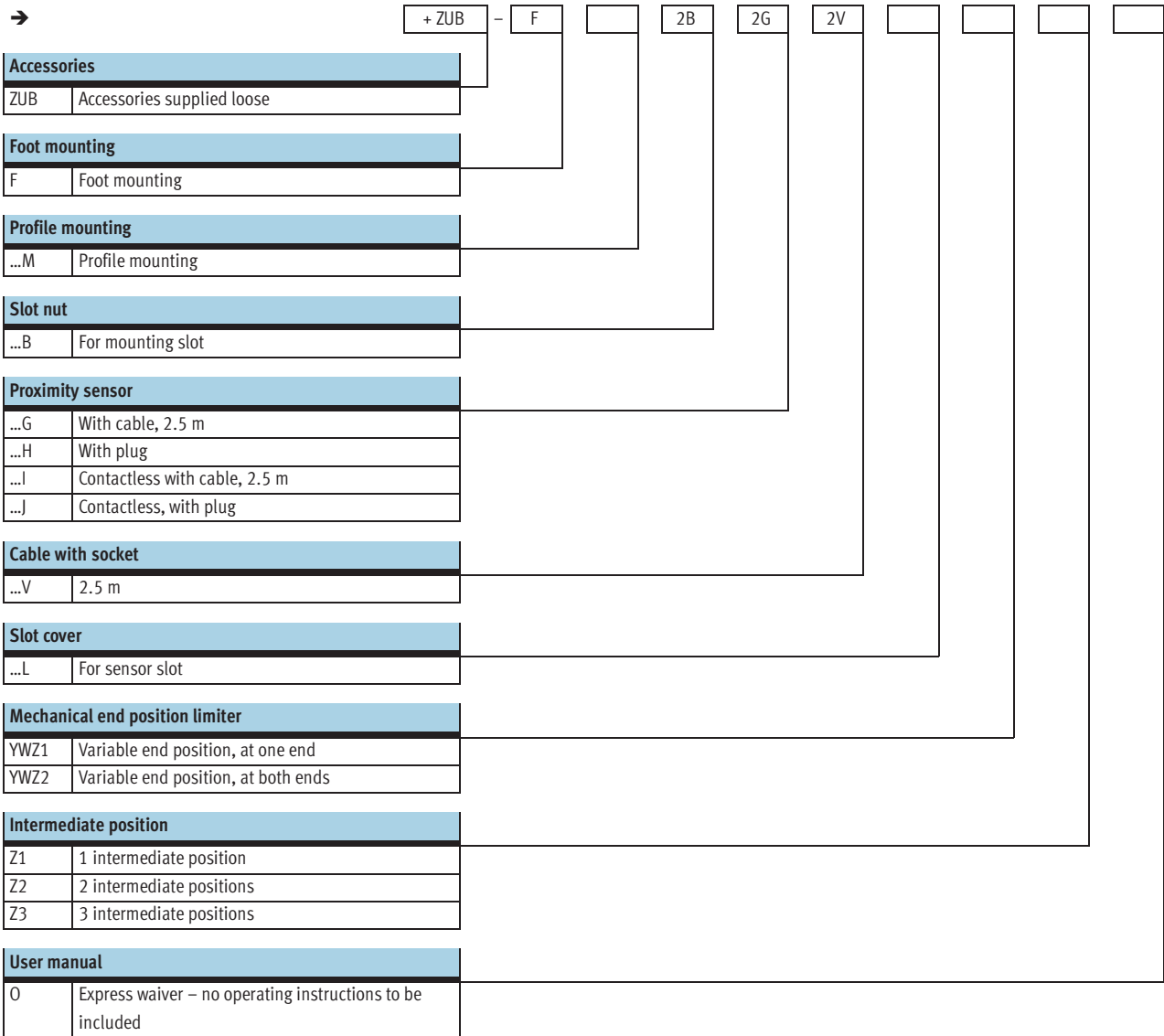

Linear drives DGC-KF, with recirculating ball bearing guide

FESTO

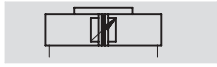

Technical data

Function



www.festo.com

Wearing parts kits
→ 58

-  - Diameter
8 ... 63 mm
-  - Stroke length
1 ... 8,500 mm



| General technical data | | | | | | | | | |
|---------------------------------------|--------|---|-------------|-------------|-------------------------|------|-----------------|-------------|-----------------|
| Piston Ø | | 8 | 12 | 18 | 25 | 32 | 40 | 50 | 63 |
| Stroke | [mm] | 1 ... 1,300 | 1 ... 1,900 | 1 ... 3,000 | 1 ... 8,500 | | | 1 ... 5,000 | |
| Pneumatic connection | | M5 | | | G $\frac{1}{8}$ | | G $\frac{1}{4}$ | | G $\frac{3}{8}$ |
| Mode of operation | | Double-acting | | | | | | | |
| Design | | Rodless drive | | | | | | | |
| Driver principle | | Slotted cylinder, mechanically coupled | | | | | | | |
| Guide | | External recirculating ball bearing guide | | | | | | | |
| Mounting position | | Any | | | | | | | |
| Cushioning → 47 | P | Non-adjustable at either end | | | - | | | | |
| | PPV | - | | | Adjustable at both ends | | | | |
| | YSR... | Self-adjusting at both ends | | | | | | | |
| Cushioning length with PPV cushioning | [mm] | - | | 16.5 | 15.5 | 17.5 | 29.5 | 29.8 | 31.1 |
| Position sensing | | For proximity sensor | | | | | | | |
| Type of mounting | | Profile mounting | | | | | | | |
| | | Foot mounting | | | | | | | |
| | | Direct mounting | | | | | | | |
| Max. speed | [m/s] | 1 | 1.2 | 3 | | | | | |
| Repetition accuracy | [mm] | 0.02 (with shock absorber YSR/YSRW) | | | | | | | |

• Note: This product conforms with the ISO 1179-1 standard and the ISO 228-1 standard.

| Operating and environmental conditions | | | | | | | | | |
|--|-------|---|----|----|---------|----|-----------|----|----|
| Piston Ø | | 8 | 12 | 18 | 25 | 32 | 40 | 50 | 63 |
| Operating pressure | [bar] | 2.5 ... 8 | | | 2 ... 8 | | 1.5 ... 8 | | |
| Operating medium | | Filtered compressed air, lubricated or unlubricated | | | | | | | |
| Ambient temperature ¹⁾ | [°C] | -10 ... +60 | | | | | | | |
| Corrosion resistance class CRC ²⁾ | | 1 | | | | | | | |
| Certification | | C-Tick | | | | | | | |

1) Note operating range of proximity sensors

2) Corrosion resistance class 1 to Festo standard 940 070

Components requiring low corrosion resistance. Transport and storage protection. Parts that do not have primarily decorative surface requirements, e.g. in internal areas that are not visible or behind covers

| Forces [N] | | | | | | | | | |
|--------------------------------|--|------|----|-----|-----|-----|-----|-------|-------|
| Piston Ø | | 8 | 12 | 18 | 25 | 32 | 40 | 50 | 63 |
| Theoretical force at 6 bar | | 30 | 68 | 153 | 295 | 483 | 754 | 1,178 | 1,870 |
| Impact energy at end positions | | → 47 | | | | | | | |

Linear drives DGC-KF, with recirculating ball bearing guide

Technical data

| Weights [g] | | | | | | | | |
|------------------------------------|-----|-----|-----|-------|-------|-------|--------|--------|
| Piston Ø | 8 | 12 | 18 | 25 | 32 | 40 | 50 | 63 |
| Basic weight with 0 mm stroke | 225 | 391 | 975 | 2,113 | 2,837 | 6,996 | 13,342 | 22,220 |
| Additional weight per 10 mm stroke | 11 | 16 | 31 | 49 | 74 | 117 | 153 | 236 |
| Moving load | 77 | 149 | 331 | 732 | 1,146 | 2,330 | 4,511 | 8,225 |

Adjustable end position range d [mm]

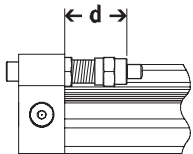

-  - Note
 The permissible kinetic energy decreases if the stroke is reduced with PPV adjustable cushioning at both ends.

| Piston Ø | 8 | 12 | 18 | 25 | 32 | 40 | 50 | 63 |
|---------------------------------------|---------------|---------------|---------------|---------------|---------------|---------------|---------------|---------------|
| Cushioning P/PPV | 11.3 ... 16.3 | 12.7 ... 17.7 | 13.8 ... 15.8 | 21.1 ... 25.1 | 25.2 ... 30.2 | 28.7 ... 33.7 | 28.7 ... 33.7 | 38.8 ... 43.8 |
| Protected guide with cushioning P/PPV | - | - | 16.9 ... 18.9 | 23.6 ... 27.6 | 25.2 ... 30.2 | 34.7 ... 39.7 | - | - |
| Cushioning YSR/YSRW | 12.8 ... 22.8 | 14 ... 24 | 14.5 ... 34.5 | 22.5 ... 47.5 | 27.3 ... 52.3 | 31 ... 56 | 31 ... 56 | 41 ... 76 |

Materials

Sectional view

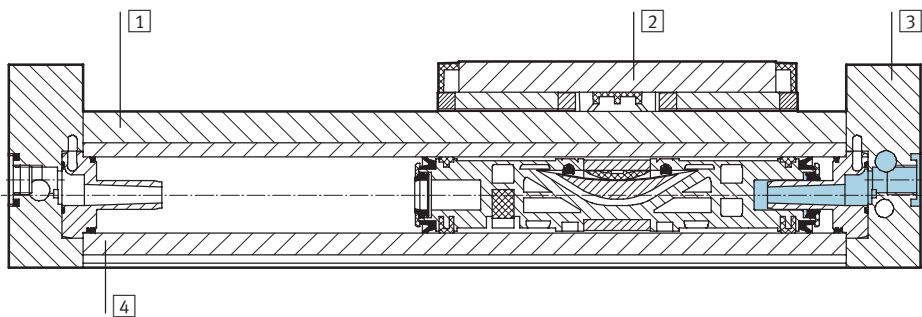

| Linear drives | | |
|---------------|--------------------------|-----------------------------------|
| 1 | Guide rail | High-alloy steel |
| 2 | Slide | High-alloy steel |
| 3 | End cap | Anodised aluminium |
| 4 | Cylinder barrel | Anodised aluminium |
| - | Piston seal | Polyurethane |
| - | Sealing band/cover strip | Polyurethane |
| - | Note on materials | Free of copper, PTFE and silicone |

Linear drives DGC-KF, with recirculating ball bearing guide

Technical data

FESTO

Influence of ferritic materials on proximity sensors

Ferritic materials (steel parts or panels) directly next to the proximity sensors can cause sensing

malfunctions. The following safety distances must be observed.

The distance depends on the position of the proximity sensor (see [1](#) and [2](#)).

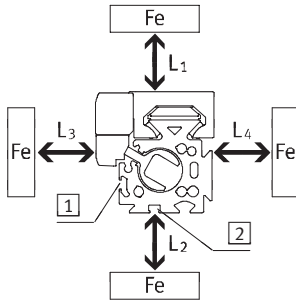

| Piston Ø | | 8 | 12 | 18 | 25 | 32 | 40 | 50 | 63 |
|-------------|------------------------|----|----|----|----|----|----|----|----|
| Distance L1 | 1 [mm] | 0 | 0 | 0 | 0 | 0 | 0 | 0 | 0 |
| | 2 [mm] | - | - | 0 | 0 | 0 | 0 | 0 | 0 |
| Distance L2 | 1 [mm] | 20 | 10 | 10 | 10 | 0 | 0 | 0 | 0 |
| | 2 [mm] | - | - | 25 | 25 | 25 | 25 | 25 | 25 |
| Distance L3 | 1 [mm] | 30 | 25 | 25 | 25 | 25 | 25 | 25 | 25 |
| | 2 [mm] | - | - | 10 | 10 | 0 | 0 | 0 | 0 |
| Distance L4 | 1 [mm] | 0 | 0 | 0 | 0 | 0 | 0 | 0 | 0 |
| | 2 [mm] | - | - | 0 | 0 | 0 | 0 | 0 | 0 |

Characteristic load values for linear drive with recirculating ball bearing guide and guide

The indicated forces and torques refer to the centre of the slide surface.

They must not be exceeded in the dynamic range. Special attention must be paid to the cushioning phase.

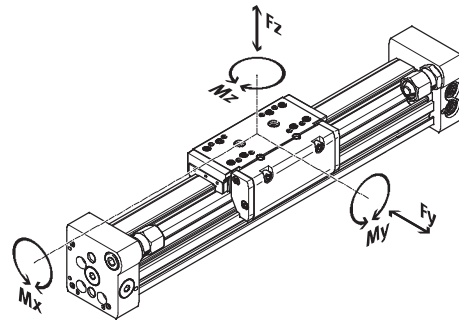

GP – Protected guide

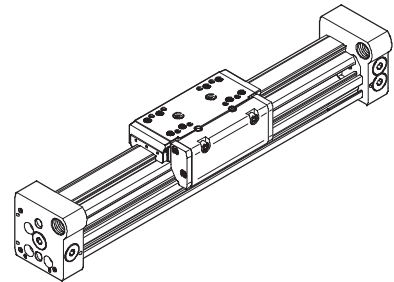

If the drive is subjected to more than two of the indicated forces and torques simultaneously, the following equation must be satisfied in addition to the indicated maximum loads:

$$\frac{F_y}{F_{y_{max}}} + \frac{F_z}{F_{z_{max}}} + \frac{M_x}{M_{x_{max}}} + \frac{M_y}{M_{y_{max}}} + \frac{M_z}{M_{z_{max}}} \leq 1$$

Permissible forces and torques

| Piston Ø | | 8 | 12 | 18 | 25 | 32 | 40 | 50 | 63 |
|--------------------------------|------|-----|-----|-------|-------|-------|-------|-------|--------|
| F _y _{max.} | [N] | 300 | 650 | 1,850 | 3,050 | 3,310 | 6,890 | 6,890 | 15,200 |
| F _z _{max.} | [N] | 300 | 650 | 1,850 | 3,050 | 3,310 | 6,890 | 6,890 | 15,200 |
| M _x _{max.} | [Nm] | 1.7 | 3.5 | 16 | 36 | 54 | 144 | 144 | 529 |
| M _y _{max.} | [Nm] | 4.5 | 10 | 51 | 97 | 150 | 380 | 634 | 1,157 |
| M _z _{max.} | [Nm] | 4.5 | 10 | 51 | 97 | 150 | 380 | 634 | 1,157 |

- Note

Sizing software
ProDrive
→ www.festo.com

Linear drives DGC-KF, with recirculating ball bearing guide

Technical data

Maximum permissible piston speed v as a function of effective load m

Piston \varnothing 8/12 with P cushioning

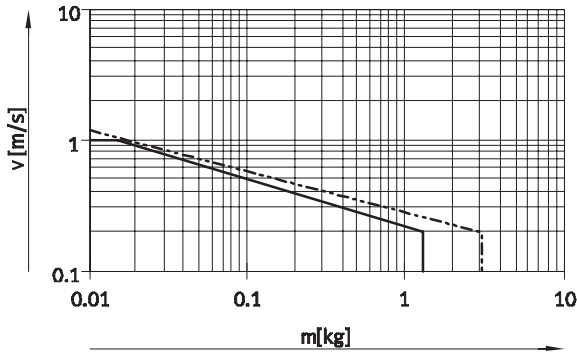

Piston \varnothing 18 ... 63 with PPV cushioning

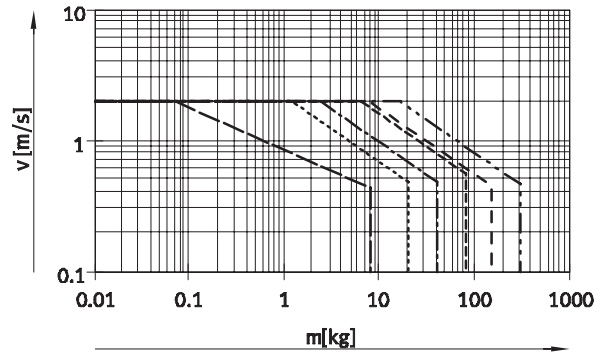

Piston \varnothing 8 ... 63 with YSR cushioning

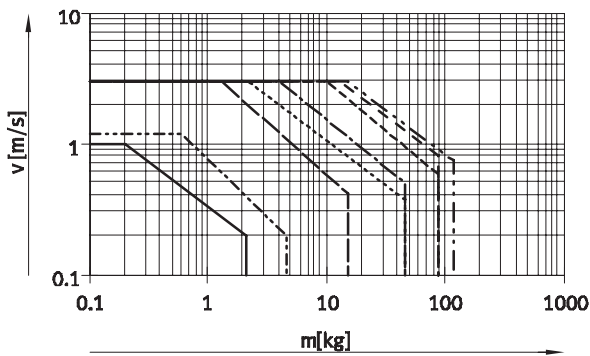

Piston \varnothing 8 ... 63 with YSRW cushioning

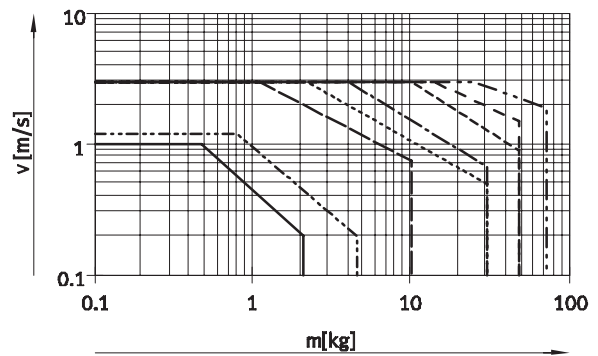

- \varnothing 8 - - - \varnothing 18 - - - - \varnothing 40
- - - \varnothing 12 - · - · \varnothing 25 - - - \varnothing 50
- · - · \varnothing 32 - - - \varnothing 63

Note
This data represents the maximum values that can be achieved. Values fluctuate in practice relative to the position of the effective load and mounting position.

Operating range of cushioning

The end position cushioning must be adjusted to ensure jerk-free operation. If the operating conditions are outside the permissible range, the

load to be moved must be cushioned using suitable equipment (shock absorbers, stops, etc.), preferably at the centre of gravity of the mass.

Note
To avoid distortion in the slide, the bearing surfaces of the attachments must maintain a flatness of at least 0.01 mm.

The data applies to a horizontal mounting position:

| Piston \varnothing | 8 | 12 | 18 | 25 | 32 | 40 | 50 | 63 |
|-------------------------|----|----|----|----|----|----|----|----|
| Distance r_{max} [mm] | 25 | 35 | 35 | 50 | 50 | 50 | 50 | 50 |

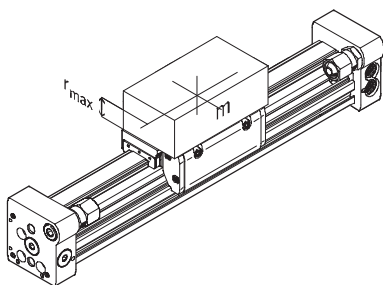

Linear drives DGC-KF, with recirculating ball bearing guide

Technical data



Number of profile mountings MUC dependent on force due to weight F and support span l

In order to limit deflection in the case of large strokes, the drive may need to be supported. The following diagrams

serve to determine the maximum permissible support span as a

function of the mounting position and the perpendicular force.

Horizontal mounting position

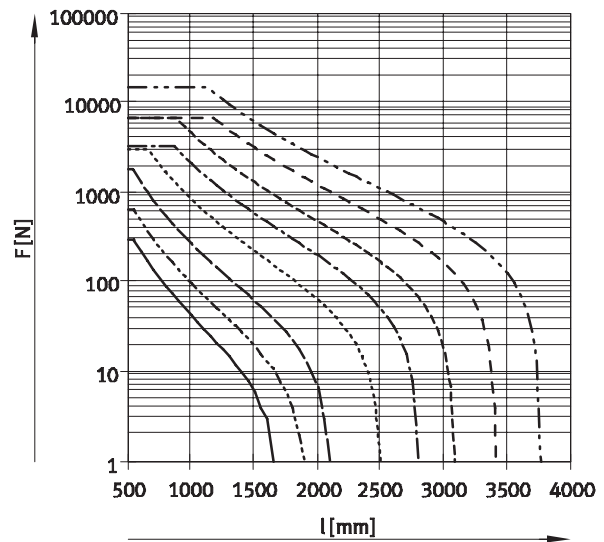
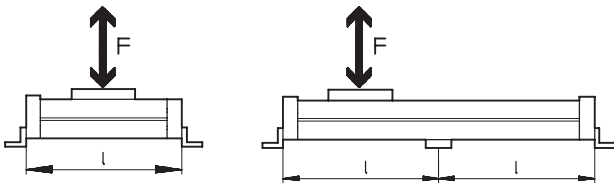

Vertical mounting position

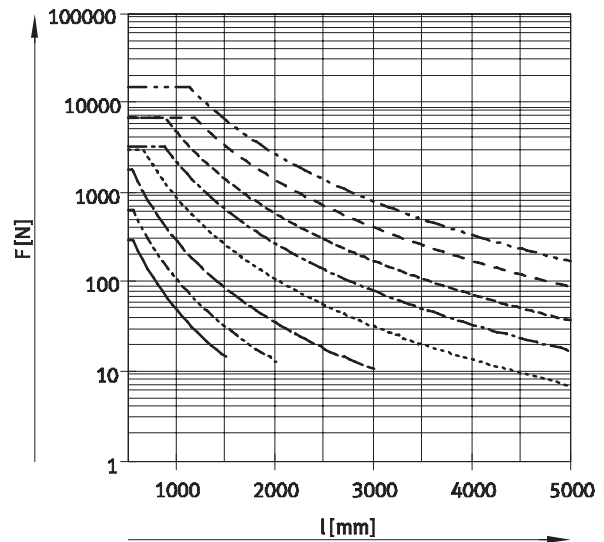
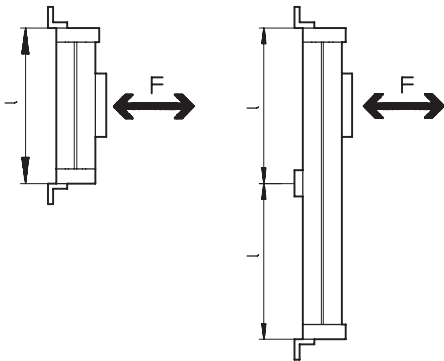

Example:

The drive DGC-25-1500 is subjected to a force of 300 N in horizontal mounting position.

The drive has an overall length of:
 $l = \text{stroke length} + L1$
 (see dimensions)
 $= 1,500 \text{ mm} + 200 \text{ mm}$
 $= 1,700 \text{ mm}$

According to the diagram, the max. support span is 1,300 mm for the drive DGC-25 with a force of 300 N.

In this example, profile mountings are required as the max. support span (1,300 mm) is smaller than the overall length of the drive (1,700 mm).

Linear drives DGC-KF, with recirculating ball bearing guide

Technical data

Dimensions Download CAD data → www.festo.com

Ø 8 and 12

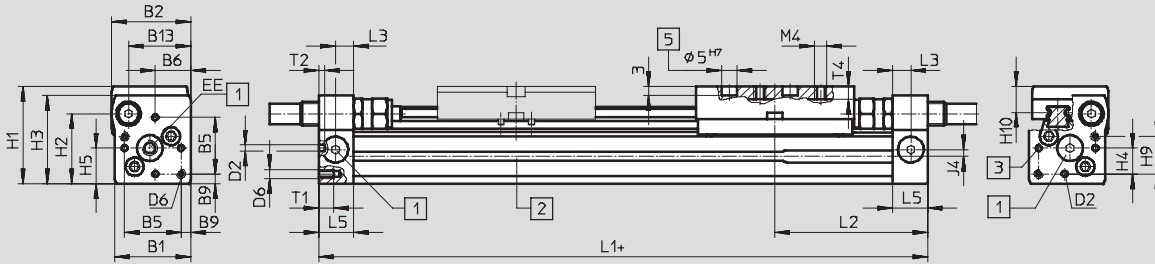

+ plus stroke length

- 1 Supply port
optional on three faces
- 2 Sensor slot for proximity sensor
- 3 Mounting hole for foot mounting or centring pin
- 4 Additional slide KL
- 5 Hole for centring pin ZBS

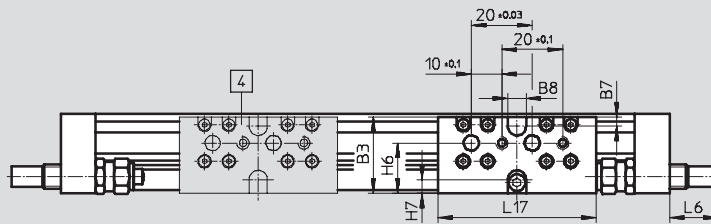

| Ø | B1 | B2 | B3 | B5 | B6 | B7 | B8 | B9 | B13 | D2 | D6 | EE |
|------|------|----|----|------|------|----|-------|------|------|------|----|----|
| [mm] | | | | | | | ±0.05 | ±0.1 | | Ø H8 | | |
| 8 | 25 | 26 | 25 | 18.6 | 11.7 | 3 | 6 | 3.2 | 20.5 | 2 | M3 | M5 |
| 12 | 30.2 | 31 | 31 | 20.6 | 13.5 | 3 | 8 | 4.8 | 25 | 2 | M4 | M5 |

| Ø | H1 | H2 | H3 | H4 | H5 | H6 | H7 | H9 | H10 | J4 | L1 | L2 |
|------|------|------|------|-----|------|------|-----|------|-----|-----|---------------|------|
| [mm] | | | | | | | | | | | +0.5/ -0.4 | |
| 8 | 32 | 23 | 29 | 8.5 | 11.7 | 16.5 | 4.5 | 12.3 | 8.7 | 2.2 | 100 | 50.1 |
| 12 | 37.5 | 28.5 | 34.5 | 8.7 | 13.5 | 20.5 | 5 | 14.7 | 9.8 | 3 | 125 | 62.1 |

| Ø | L3 | L5 | L6 | | | L17 | T1 | T2 | T4 | Stroke tolerance |
|------|----|------|----|------|------|-----|----|----|-----|------------------|
| | | | P | YSR | YSRW | | | | | |
| [mm] | | | | | | | | | | |
| 8 | 6 | 11.5 | 0 | 16 | 16.2 | 52 | 5 | 2 | 4.3 | 0 ... 1.7 |
| 12 | 8 | 16 | 0 | 11.3 | 12.3 | 65 | 6 | 2 | 5 | |

Profile barrel

Ø 8

Ø 12

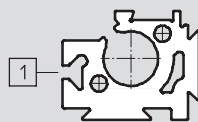
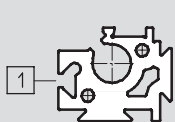

1 Sensor slot for proximity sensor

Linear drives DGC-KF, with recirculating ball bearing guide

Technical data

Dimensions

Download CAD data → www.festo.com

∅ 18 ... 40

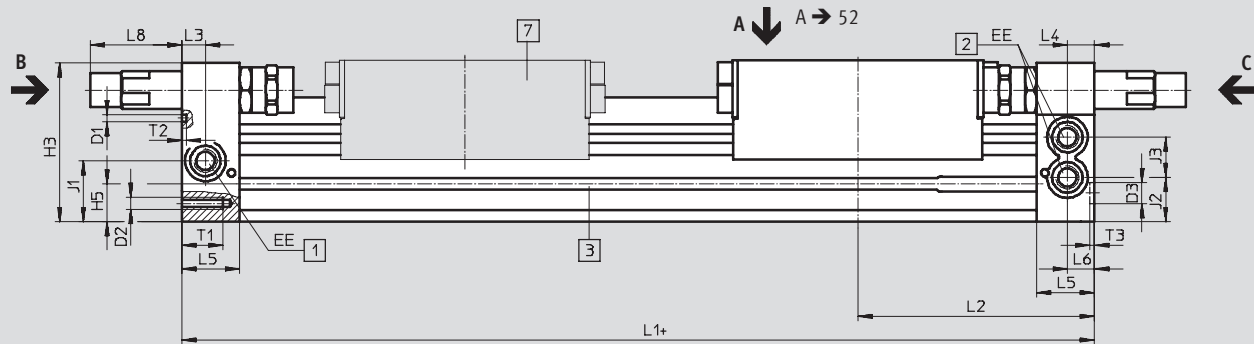

View C

∅ 18 ... 40

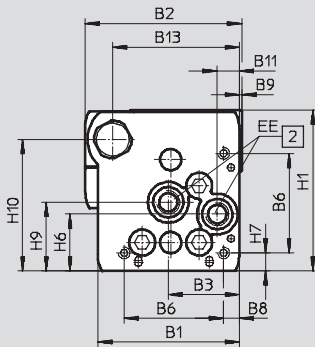

View B

∅ 18

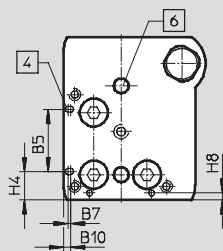

∅ 25 ... 40

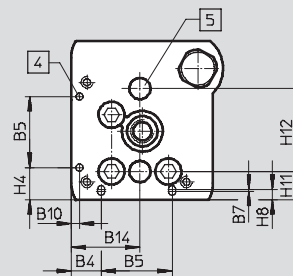

∅ 18 ... 40

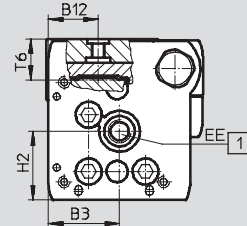

∅ 50/63

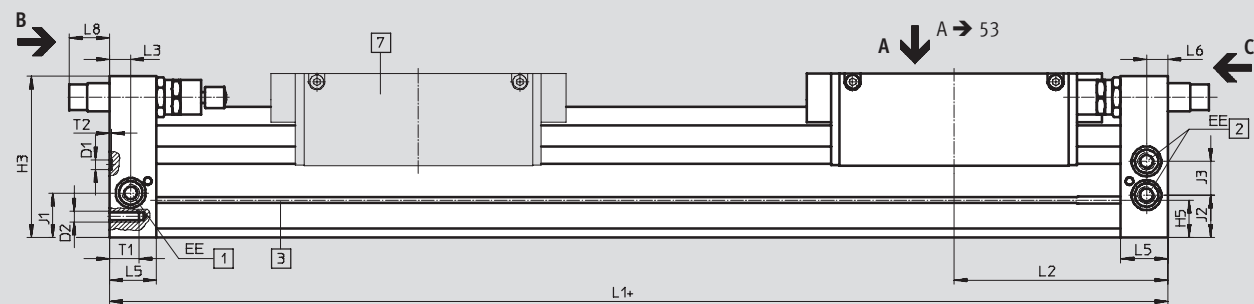

View C

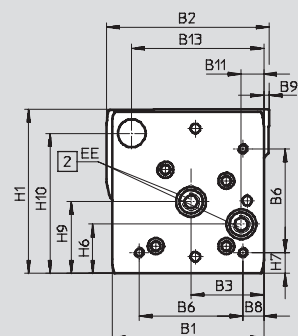

View B

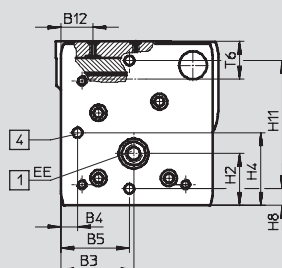

- + plus stroke length
- 1 Supply port optional on two faces
- 2 Supply port optional on two faces, for supplying from one end
- 3 Sensor slot for proximity sensor
- 4 Mounting hole for foot mounting HPC
- 5 Hole for centring sleeve ZBH
- 6 Hole for centring pin ZBS
- 7 Additional slide

Linear drives DGC-KF, with recirculating ball bearing guide

Technical data

| ∅ [mm] | B1 | B2 | B3 | B4 | B5 ±0.05 | B6 | B7 | B8 | B9 | B10 | B11 | B12 |
|-----------|------|-------|------|-------|-------------|------|-----|------|-----|-----|------|------|
| 18 | 44.5 | 49.9 | 19.5 | 8.8 | 21 | 31 | 0.8 | 3.8 | 1 | 2.4 | 5.5 | 15.5 |
| 25 | 59.8 | 66 | 30 | 12.65 | 30 | 42 | 1 | 6.65 | 1 | 3.5 | 9.3 | 21 |
| 32 | 73 | 79 | 38.5 | 5.7 | 63.1 | 57.5 | – | 8.5 | 1.5 | 14 | 14.9 | 18 |
| 40 | 91 | 98.5 | 45 | 17.2 | 55 | 65 | – | 12.2 | 2 | 8 | 16.5 | 24.8 |
| 50 | 113 | 126.5 | 60 | 8 | 52.8 | 81.6 | – | 12 | – | – | 21 | 24 |
| 63 | 142 | 149 | 68 | 15.5 | 68 | 97 | – | 19.5 | 5 | – | 21 | 30 |

| ∅ [mm] | B13 | B14 | D1 ∅ | D2 | D3 ∅ H7 | EE | H1 | H2 | H3 | H4 ±0.2 | H5 | H6 |
|-----------|-------|------|-----------------|-----|---------------|-----------------|-------|------|-------|------------|------|------|
| 18 | 39 | 19.5 | 2±0.05 | M4 | 5 | M5 | 56.3 | 23.1 | 55 | 9.6 | 13.4 | 20 |
| 25 | 53 | 30 | 3±0.05 | M5 | 9 | G $\frac{1}{8}$ | 68 | 29 | 67 | 13.65 | 15.8 | 24 |
| 32 | 65 | 38.5 | 3±0.05 | M6 | 9 | G $\frac{1}{8}$ | 78.5 | 30 | 77 | 5.7 | 17 | 27.7 |
| 40 | 80.5 | 45 | 4±0.05 | M6 | 9 | G $\frac{1}{4}$ | 99.5 | 41.5 | 97.5 | 17.2 | 25 | 36.5 |
| 50 | 97 | – | 9 ^{H7} | M8 | 9 | G $\frac{1}{4}$ | 124.5 | 38.5 | 122.5 | 52.8 | 29.3 | 36 |
| 63 | 123.5 | – | 9 ^{H7} | M10 | 9 | G $\frac{3}{8}$ | 153.5 | 48.5 | 151 | 68 | 34.8 | 46 |

| ∅ [mm] | H7 | H8 | H9 | H10 | H11 | H12 ±0.05 | J1 | J2 | J3 | L1 | |
|-----------|------|------|------|-------|------------|--------------|------|------|------|-----------------|--------------------|
| | | | | | | | | | | KF +0.9/–0.2 | KF-GP +0.9/–0.2 |
| 18 | 4.6 | 2.4 | 25.2 | 46 | 8.5±0.15 | 30 | 20 | 16.5 | 11 | 150 | 157 |
| 25 | 7.65 | 4.5 | 29 | 55.5 | 12±0.15 | 35 | 26.1 | 18.6 | 17 | 200 | 205 |
| 32 | 8.5 | 14 | 35.2 | 63.8 | 11.45±0.15 | 50 | 30 | 22 | 18.5 | 250 | 250 |
| 40 | 12.2 | 8 | 44 | 81.5 | 15±0.15 | 60 | 35 | 26 | 26 | 300 | 312 |
| 50 | 12 | 8 | 53 | 104.5 | 100±0.05 | – | 30.5 | 30.5 | 28 | 350 | – |
| 63 | 19.5 | 15.5 | 67 | 131 | 120±0.05 | – | 41.5 | 39.5 | 31.5 | 400 | – |

| ∅ [mm] | L2 | | L3 | L4 | L5 | L6 | L8 | | | T1 | T2 | T3 +0.2 | T6 | Stroke tolerance |
|-----------|-------|-------|------|------|------|------|-----|------|------|------|---------------------|------------|-------|------------------|
| | KF | KF-GP | | | | | PPV | YSR | YSRW | | | | | |
| 18 | 74.5 | 78 | 5.7 | 5.8 | 15 | 5.5 | 0 | 29.9 | 32.4 | 9 | 2 | 3.1 | 15 | 0 ... 2.5 |
| 25 | 100 | 102.5 | 10.5 | 10.6 | 24.5 | 10.6 | 0 | 35.6 | 38.6 | 17.5 | 2 | 2.1 | 17.3 | |
| 32 | 124.8 | 124.8 | 14.5 | 14.5 | 30.5 | 14.5 | 0 | 19.5 | 28 | 15 | 2 | 2.1 | 20 | |
| 40 | 150 | 156 | 14.6 | 14.6 | 33.5 | 14.6 | 0 | 38.5 | 43.5 | 20 | 3 | 2.1 | 25.7 | |
| 50 | 175 | – | 17 | – | 41 | 17 | 0 | 31 | 36.3 | 24 | 2.1 ^{+0.2} | 2.1 | 28.75 | |
| 63 | 200 | – | 20 | – | 44 | 20 | 0 | 38.3 | 48.3 | 27.5 | 2.1 ^{+0.2} | 2.1 | 36.1 | |

– | – Note: This product conforms with the ISO 1179-1 standard and the ISO 228-1 standard.

Linear drives DGC-KF, with recirculating ball bearing guide

Technical data

Dimensions Download CAD data → www.festo.com

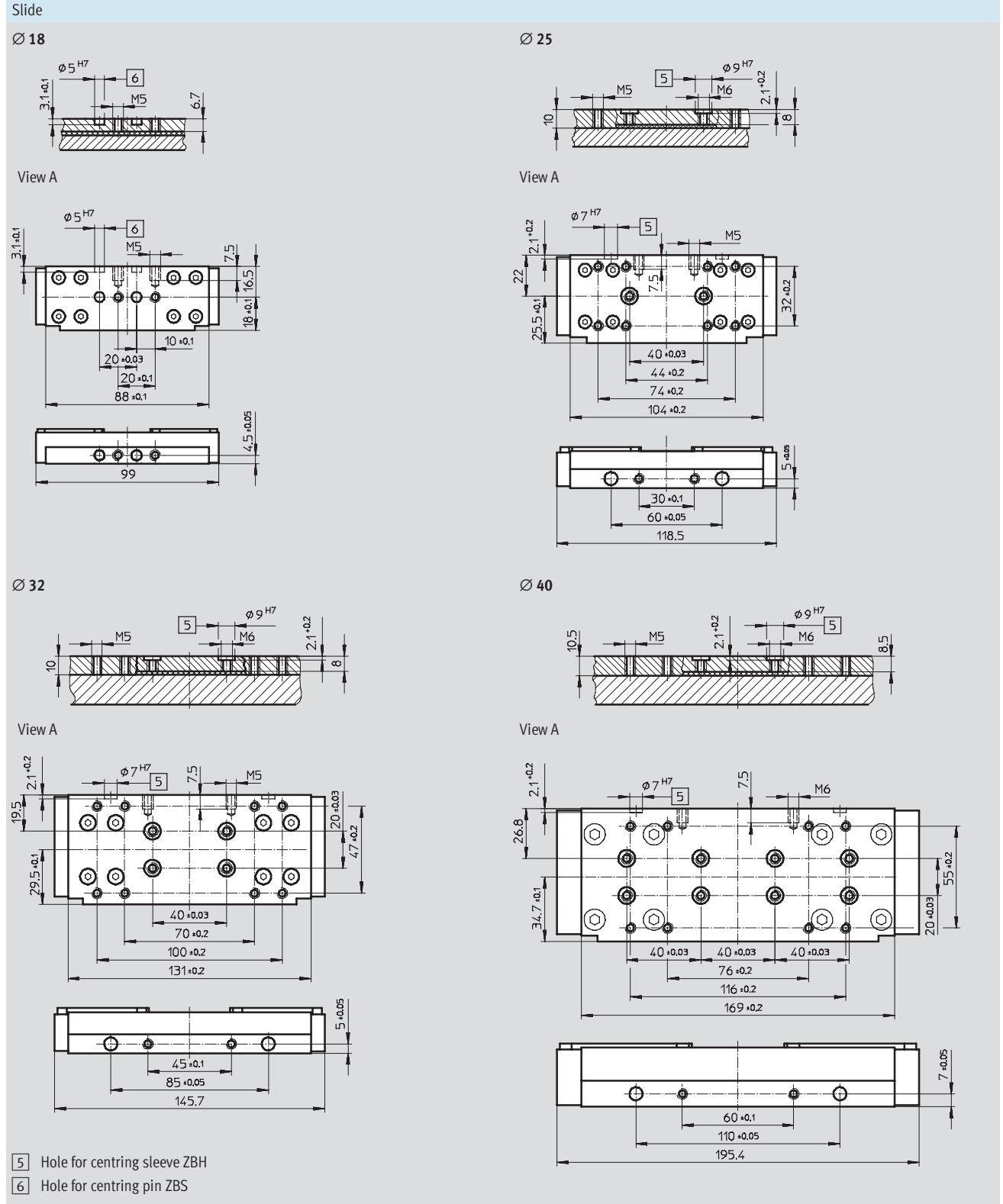

Linear drives DGC-KF, with recirculating ball bearing guide

Technical data

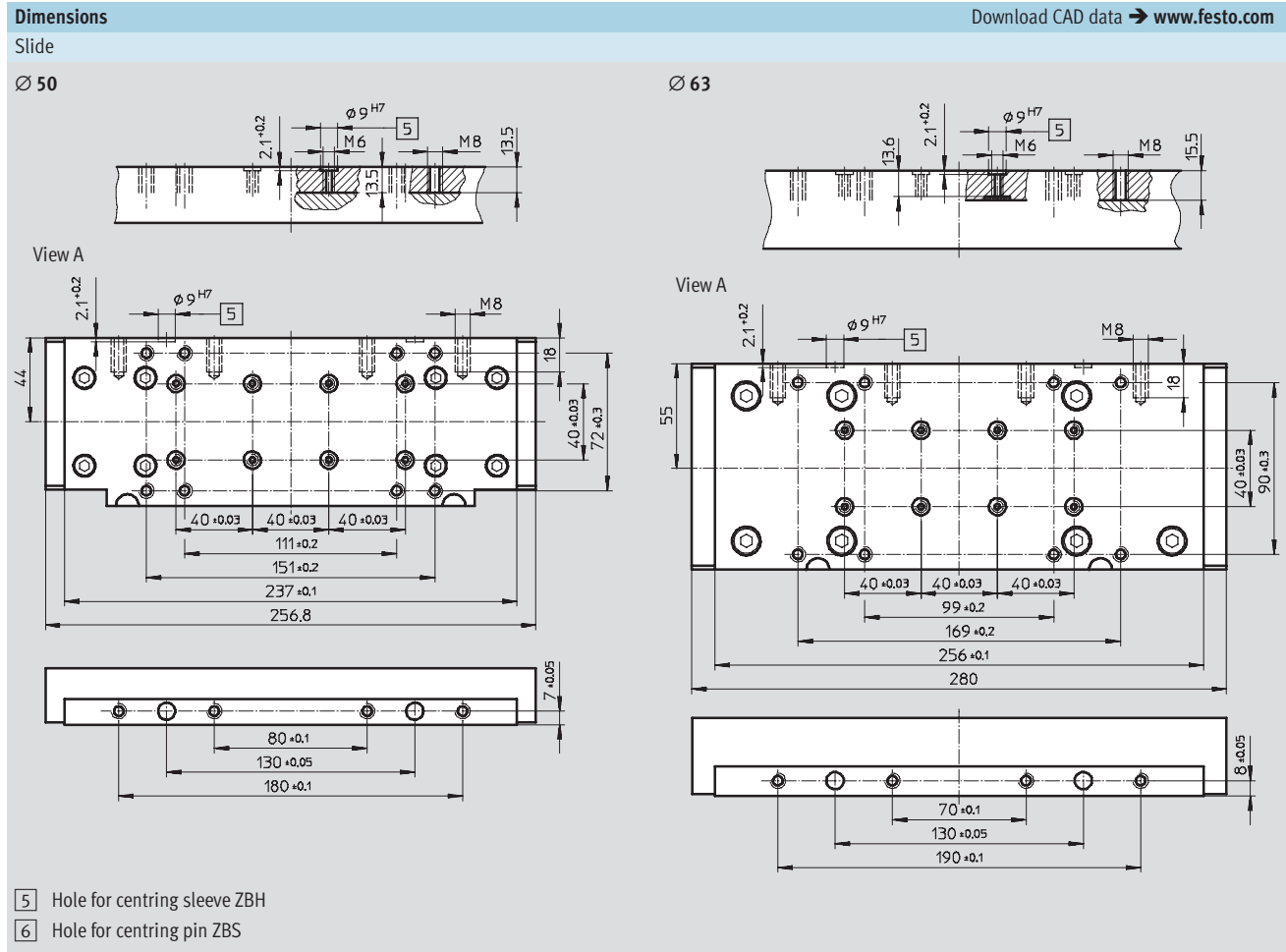

Linear drives DGC-KF, with recirculating ball bearing guide

Technical data

Dimensions Download CAD data → www.festo.com

Slide, variant GP – Protected recirculating ball bearing guide

Ø 18

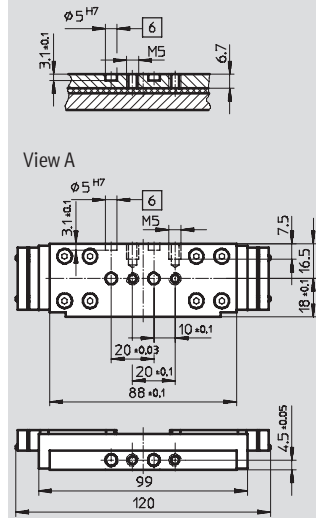

Ø 25

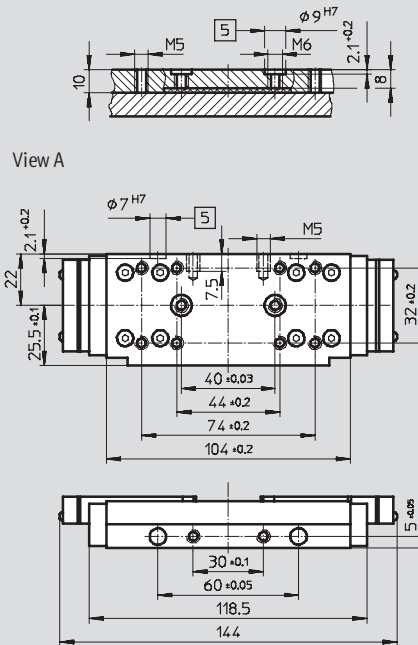

Ø 32

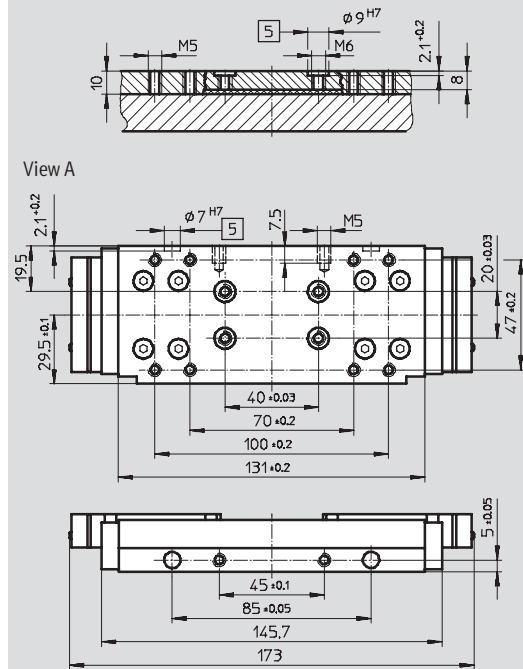

Ø 40

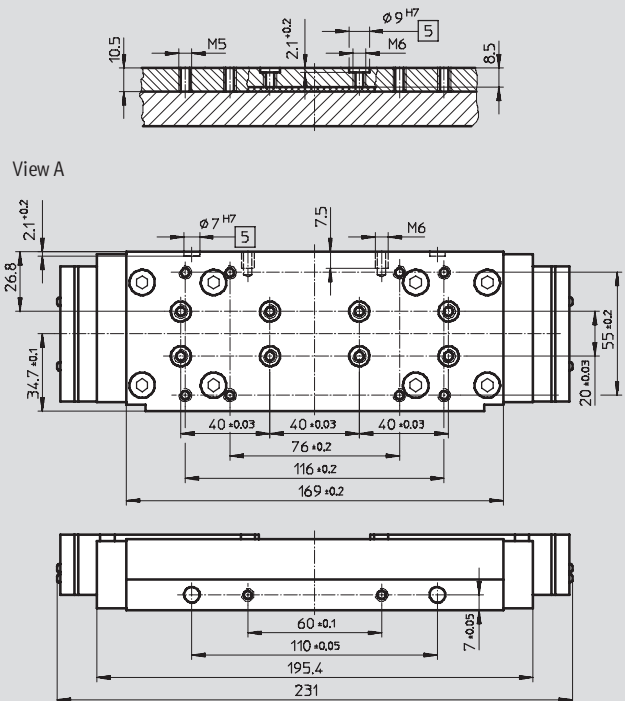

- 5 Hole for centring sleeve ZBH
- 6 Hole for centring pin ZBS

Linear drives DGC-KF, with recirculating ball bearing guide

Technical data

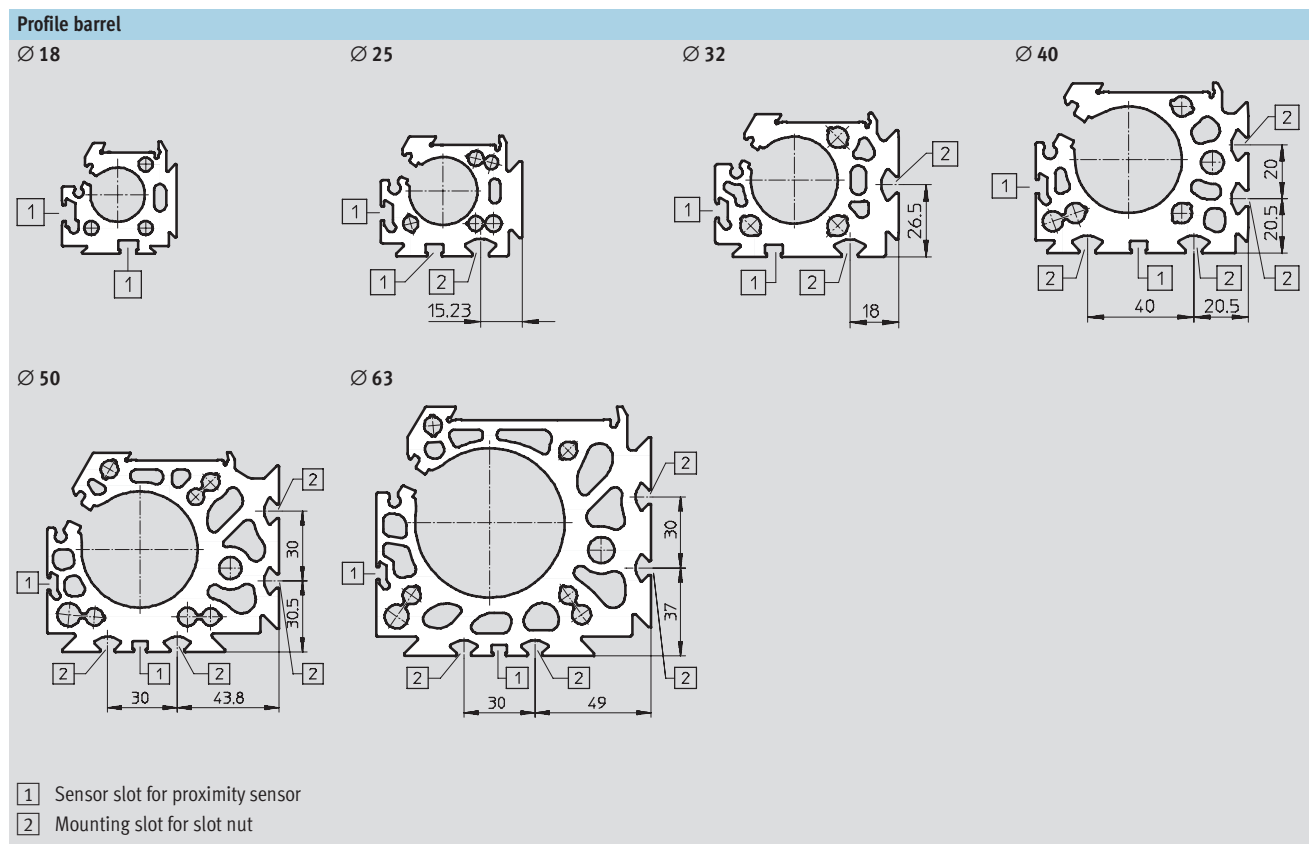

Linear drives DGC-KF, with recirculating ball bearing guide

Ordering data – Modular products

Order code

Mandatory data/options

-  - Note

1) End stops or shock absorbers must not be removed.

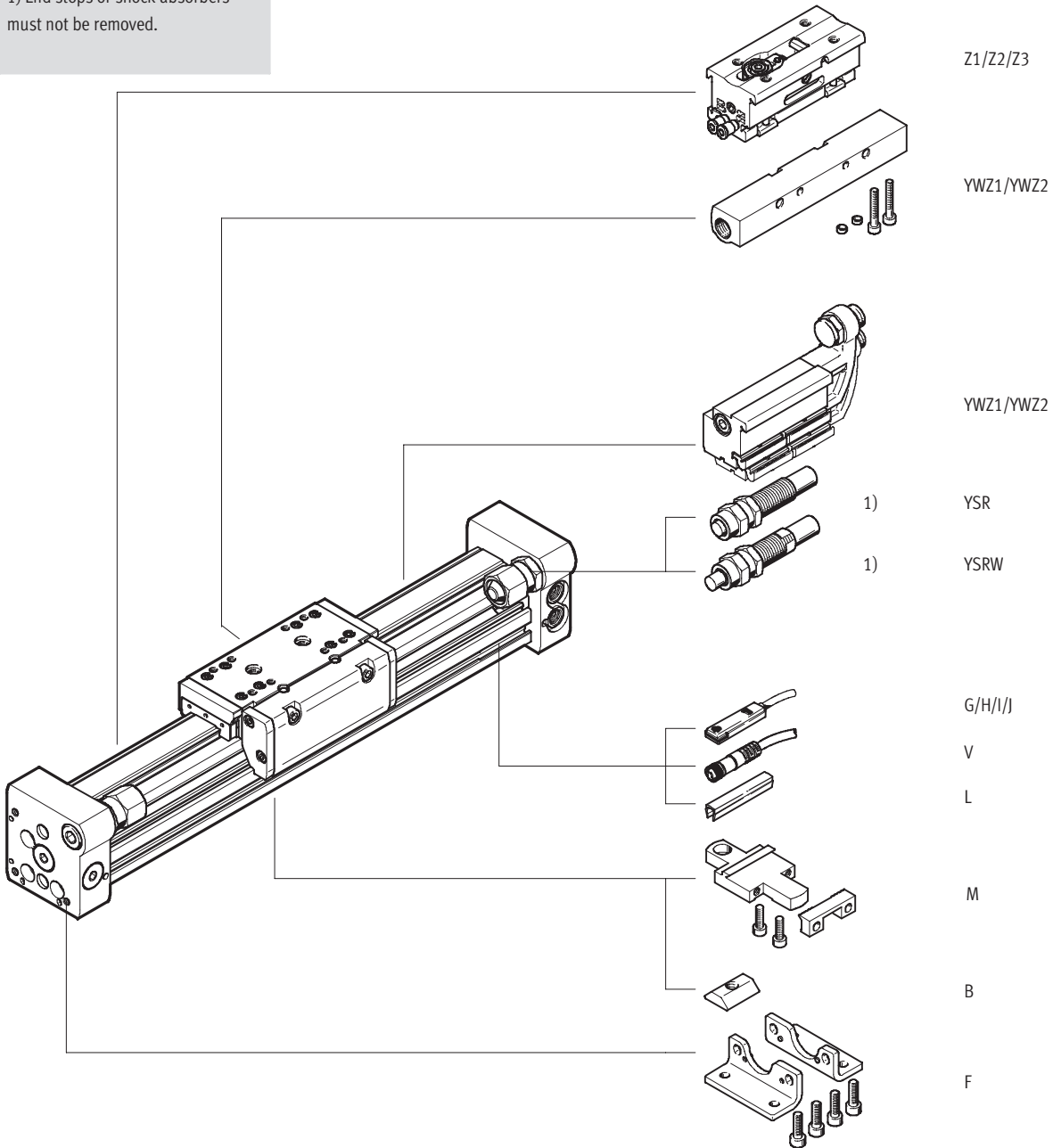

Linear drives DGC-KF, with recirculating ball bearing guide

Ordering data – Modular products

| | | |
|-------------------|-------------------------------|--|
| Order code | KL/KR – With additional slide | GP – With protected recirculating ball bearing guide |
|-------------------|-------------------------------|--|

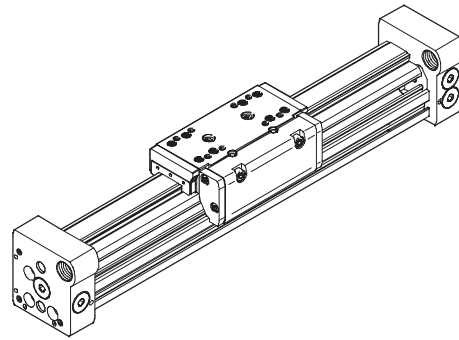
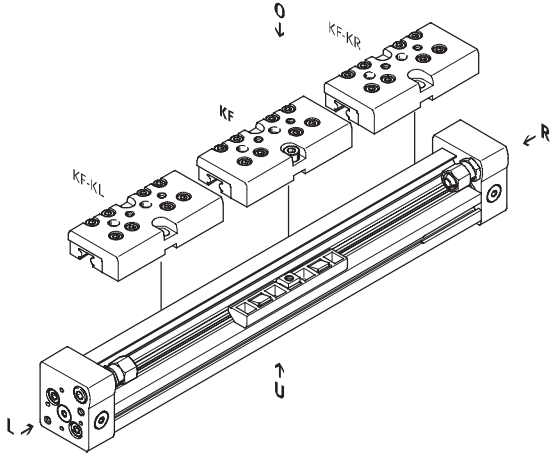

Effective stroke reduction when ordering an additional slide KL or KR

For a guide axis DGC with additional slide, the effective stroke is reduced by the length of the additional slide and the distance between both slides.

Given:
 DGC-12-500-...
 L = 20 mm
 L17 = 65 mm

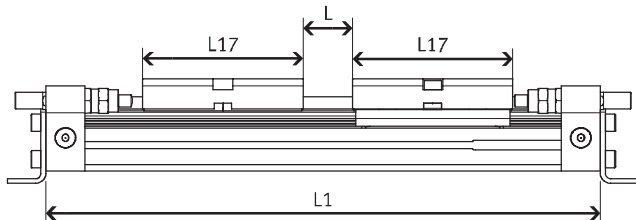

| Ø [mm] | 8 | 12 | 18 | 25 | 32 | 40 | 50 | 63 |
|--------|----|----|----|-------|-------|-------|-------|-----|
| L17 | 52 | 65 | 99 | 118.5 | 145.7 | 195.4 | 256.8 | 280 |

The effective stroke is reduced to
 415 mm = 500 mm – 20 mm – 65 mm

Linear drives DGC-KF, with recirculating ball bearing guide

Ordering data – Modular products

| M Mandatory data → | | | | | | |
|----------------------|----------|----------|------------|-------|-------------------------|------------------|
| Module No. | Function | Piston Ø | Stroke | Guide | Cushioning | Position sensing |
| 530 906 | DGC | 8 | 1 ... 8500 | KF | P PPV YSR YSRW | A |
| 530 907 | | | | | | |
| 532 446 | | | | | | |
| 532 447 | | | | | | |
| 532 448 | | | | | | |
| 532 449 | | | | | | |
| 532 450 | | | | | | |
| 532 451 | | | | | | |
| Order example | | | | | | |
| 530 907 | DGC | - 12 | - 250 | - KF | - YSRW | - A |

| Ordering table | | | | | | | | | | | | |
|--------------------|---|---------|------------|---------|---|---------|------------|---------|-----------------|-------|---------------|--|
| Size | 8 | 12 | 18 | 25 | 32 | 40 | 50 | 63 | Condi- tions | Code | Enter code | |
| M Module No. | 530 906 | 530 907 | 532 446 | 532 447 | 532 448 | 532 449 | 532 450 | 532 451 | | | | |
| Function | Linear drive | | | | | | | | | DGC | DGC | |
| Piston Ø [mm] | 8 | 12 | 18 | 25 | 32 | 40 | 50 | 63 | | -... | | |
| Stroke [mm] | 1 ... 1300 | | 1 ... 1900 | | 1 ... 3000 | | 1 ... 8500 | | 1 ... 5000 | | -... | |
| Guide | Recirculating ball bearing guide | | | | | | | | | -KF | -KF | |
| Cushioning | Flexible cushioning rings/pads at both ends | | - | - | - | - | - | - | | -P | | |
| | - | | - | | Pneumatic cushioning, adjustable at both ends | | | | | | -PPV | |
| | Shock absorber, self-adjusting | | | | | | | | | -YSR | | |
| | Shock absorber, self-adjusting, progressive | | | | | | | | | -YSRW | | |
| ↓ Position sensing | For proximity sensor | | | | | | | | | -A | -A | |

Transfer order code

Linear drives DGC-KF, with recirculating ball bearing guide

Ordering data – Modular products

→ **0** Options

| Slide | Additional slide at left | Additional slide at right | Accessories | Accessories supplied loose | Intermediate position | User manual |
|-------|--------------------------|---------------------------|-------------|---|-----------------------|-------------|
| GP | KL | KR | | F, ...M, ...B, ...G, ...H, ...I, ...J, ...V, ...L, YWZ1, YWZ2 | Z1, Z2, Z3 | 0 |
| - | - KL | - KR | ZUB | - F2M | - | - |

| Ordering table | | | | | | | | | | | | |
|------------------------------------|---|---------|--|-------------------------------------|----|----|----|-----|------------|-------------|-------------|--|
| Size | 8 | 12 | 18 | 25 | 32 | 40 | 50 | 63 | Conditions | Code | Enter code | |
| 0 Slide | - | - | Protected recirculating ball bearing guide | | | - | - | [1] | | -GP | | |
| Additional slide at left | Additional slide, standard, left | | | | | | | [2] | | -KL | | |
| Additional slide at right | Additional slide, standard, right | | | | | | | [2] | | -KR | | |
| Accessories | Supplied loose (can be retrofitted) | | | | | | | | | ZUB- | ZUB- | |
| Foot mounting | 1 | | | | | | | | | F | | |
| Profile mounting | 1 ... 9 | | | | | | | | | ...M | | |
| Slot nut for mounting slot | - | - | - | 1 ... 9 | | | | | | ...B | | |
| Proximity sensor | Cable, 2.5 m | 1 ... 9 | | | | | | | | ...G | | |
| | M8 plug | 1 ... 9 | | | | | | | | ...H | | |
| Proximity sensor, contactless, PNP | Cable, 2.5 m | 1 ... 9 | | | | | | | | ...I | | |
| | M8 plug | 1 ... 9 | | | | | | | | ...J | | |
| Cable with socket | M8, 2.5 m | 1 ... 9 | | | | | | | | ...V | | |
| Slot cover for sensor slot | - | - | 1 ... 9 | | | | | | | ...L | | |
| Mechanical end position limiter | - | | | Variable end position, at one end | | | | [3] | | YWZ1 | | |
| | - | | | Variable end position, at both ends | | | | [3] | | YWZ2 | | |
| Intermediate position | - | | | 1 intermediate position | | | - | - | [4] | | -Z1 | |
| | - | | | 2 intermediate positions | | | - | - | [4] | | -Z2 | |
| | - | | | 3 intermediate positions | | | - | - | [4] | | -Z3 | |
| User manual | Express waiver – no operating instructions to be included (already available) | | | | | | | | | -0 | | |

- 1** **GP** Not with cushioning YSR and YSRW
- 2** **KL, KR** Not with additional slide left (-KL) or additional slide right (-KR)
 For a linear drive DGC with additional slide, the effective stroke is reduced by the length of the additional slide and the distance between both slides.
 Not with cushioning PPV
- 3** **YWZ1, YWZ2** Only with cushioning YSR or YSRW
- 4** **Z1, Z2, Z3** Only with cushioning YSR or YSRW and mechanical end position limiter YWZ1 or YWZ2

Transfer order code

- - - **ZUB** - - -

| Ordering data – Wearing parts kits | | | | | | |
|------------------------------------|----------|-----------|----------|----------|--------|--|
| Piston Ø | Part No. | Type | Piston Ø | Part No. | Type | |
| 8 | 665 335 | DGC-8-KF | 32 | 684 488 | DGC-32 | |
| 12 | 665 336 | DGC-12-KF | 40 | 684 489 | DGC-40 | |
| 18 | 684 486 | DGC-18 | 50 | 719 825 | DGC-50 | |
| 25 | 684 487 | DGC-25 | 63 | 719 826 | DGC-63 | |

Linear drives DGC

Accessories



Foot mounting HPC
(order code: F)

Material:
Galvanised steel

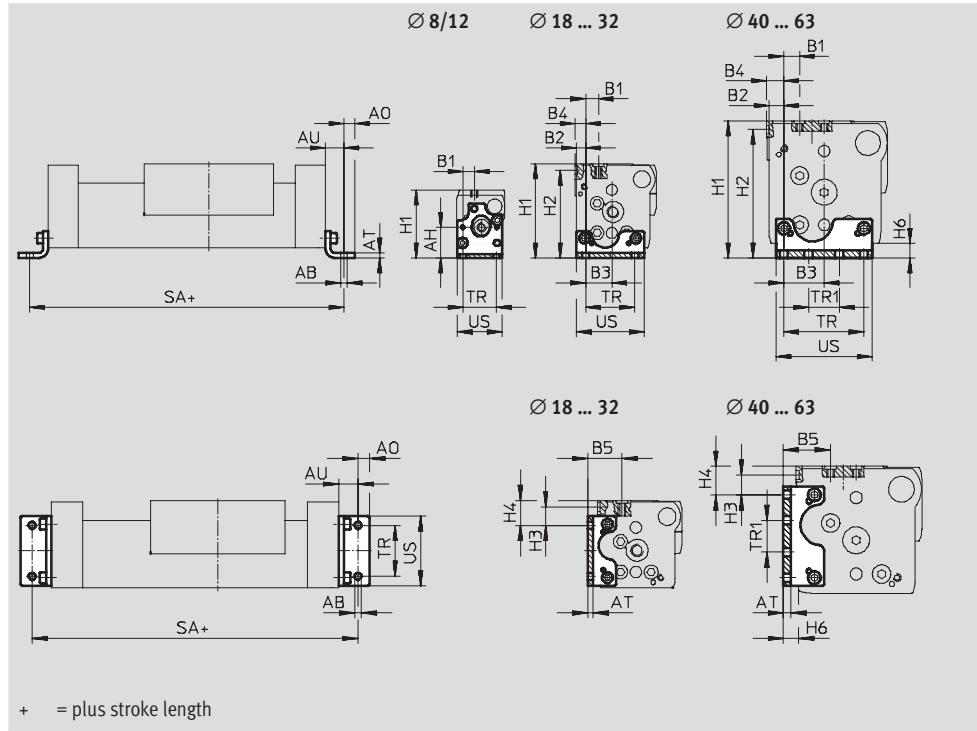

| Dimensions and ordering data | | | | | | | | | | | | | | | |
|------------------------------|---------|------|------|----|-------|------|-------|------|-------|------|------|-------|-------|------|-------|
| For Ø | AB Ø | AH | AO | AT | AU | B1 | | B2 | B3 | B4 | | B5 | | H1 | |
| | | | | | | G | GF/KF | | | GF | KF | G | GF/KF | G | GF/KF |
| 8 | 3.4 | 16.7 | 3 | 2 | 9 | 6 | 6 | - | - | - | - | - | - | 37 | 37 |
| 12 | 4.5 | 18.5 | 4.5 | 2 | 11.5 | 5.4 | 5.4 | - | - | - | - | - | - | 42.5 | 42.5 |
| 18 | 5.5 | - | 6.75 | 3 | 13.25 | 15 | 11.2 | 4.3 | 15.2 | - | 5.3 | 27 | 23.2 | 57.5 | 64 |
| 25 | 5.5 | - | 9 | 4 | 15 | 12.5 | 13.35 | 7.65 | 21.35 | - | 8.65 | 28.65 | 29.5 | 67 | 76.5 |
| 32 | 6.6 | - | 10 | 5 | 19 | 11.5 | 9 | 9 | 29.5 | - | 10.5 | 29.5 | 27 | 82 | 87.5 |
| 40 | 6.6 | - | 10 | 6 | 20 | 7.6 | 12.6 | 12.2 | 32.8 | - | 14.2 | 31.8 | 36.8 | 100 | 111.5 |
| 50 | 9 | - | 11 | 8 | 25 | 12.5 | 12.5 | 11.5 | 48.5 | 11.5 | 11.5 | 41 | 41 | 137 | 141.5 |
| 63 | 11 | - | 13.5 | 8 | 28 | 17.5 | 17.5 | 12.5 | 55.5 | 6.5 | 17.5 | 49 | 49 | 159 | 172.5 |

| For Ø | H2 | H3 | H4 | | H6 | SA | TR | TR1 | US | Weight | Part No. | Type |
|-------|-------|-------|------|-------|-----|-------|------|------|------|--------|----------|--------|
| | | | G | GF/KF | | | | | | | | |
| 8 | - | - | - | - | 5 | 118 | 18 | - | 24.4 | 25 | 526 385 | HPC-8 |
| 12 | - | - | - | - | 5 | 148 | 20 | - | 29.6 | 41 | 526 388 | HPC-12 |
| 18 | 59.5 | 16 | 14 | 21.2 | 7.7 | 176.5 | 30 | - | 38.6 | 58 | 533 667 | HPC-18 |
| 25 | 71.5 | 14.35 | 9.85 | 19.35 | 8.5 | 230 | 40 | - | 55 | 131 | 533 668 | HPC-25 |
| 32 | 82.5 | 8 | 7.5 | 13 | 9 | 288 | 56.5 | 19.5 | 68 | 239 | 533 669 | HPC-32 |
| 40 | 104.5 | 15.3 | 10.8 | 22.3 | 12 | 340 | 65 | 25 | 78 | 348 | 533 670 | HPC-40 |
| 50 | 134.5 | 23.4 | 25.9 | 30.4 | 17 | 400 | 82.6 | 47.4 | 102 | 754 | 545 236 | HPC-50 |
| 63 | 164.5 | 22 | 24 | 30 | 19 | 456 | 111 | 39 | 133 | 1,245 | 545 237 | HPC-63 |

Linear drives DGC

Accessories



Foot mounting HPC-S
(when replacing linear drive DGPL
with linear drive DGC-GF/-KF)

Material:
Galvanised steel

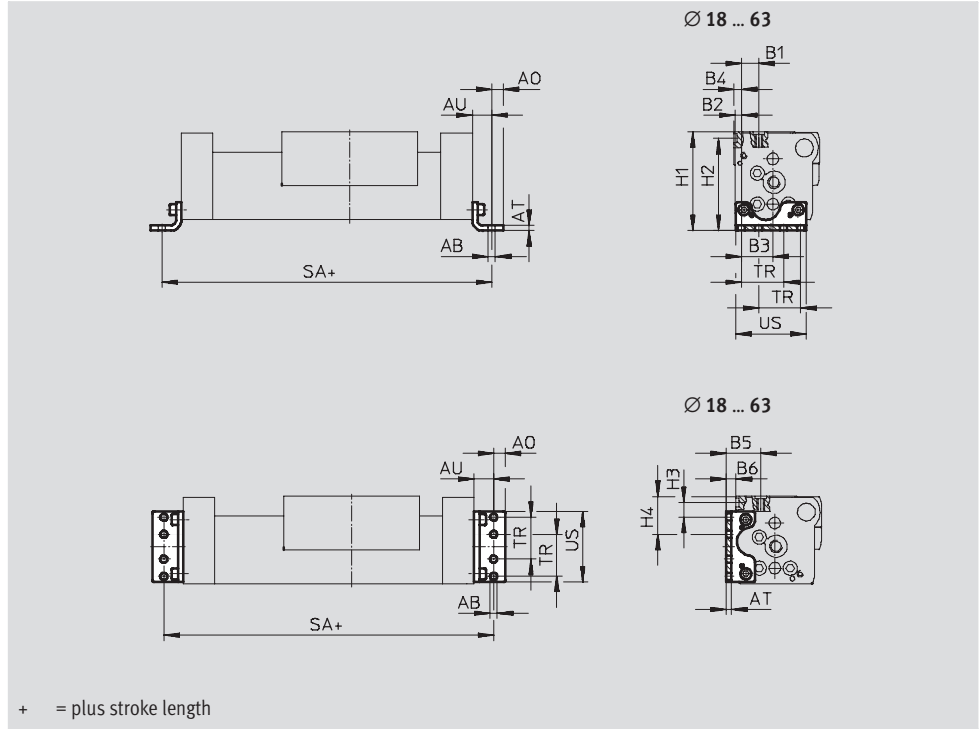

| Dimensions and ordering data | | | | | | | | | | |
|------------------------------|-----|------|----|-------|-------|------|-------|------|------|-----|
| For Ø | AB | AO | AT | AU | B1 | B2 | B3 | B4 | B5 | B6 |
| [mm] | Ø | | | | | | | | | |
| 18 | 5.5 | 4.75 | 3 | 13.25 | 12 | 3.5 | 15.6 | 4.5 | 24 | 7.5 |
| 25 | 5.5 | 6 | 3 | 13 | 16.25 | 4.75 | 24.25 | 5.75 | 29.5 | 7.5 |
| 32 | 6.6 | 7 | 4 | 17 | 9 | 9 | 29.5 | 10.5 | 27 | 7.5 |
| 50 | 9 | 11 | 8 | 25 | 12.5 | 11.5 | 48.5 | 11.5 | 38 | 14 |
| 63 | 11 | 13.5 | 8 | 28 | 17.5 | 12.5 | 55.5 | 17.5 | 37 | 2 |

| For Ø | H1 | H2 | H3 | H4 | SA | TR | US | Weight | Part No. | Type |
|-------|-------|-------|-------|-------|----------------|------|-----|--------|----------|----------|
| [mm] | | | | | | ±0.1 | | [g] | | |
| 18 | 64 | 59.5 | 15.9 | 28 | 176.5+0.9/-0.2 | 24 | 40 | 54 | 535 600 | HPC-18-S |
| 25 | 75.5 | 70.5 | 11.45 | 29.75 | 226+0.9/-0.2 | 32.5 | 55 | 89 | 535 601 | HPC-25-S |
| 32 | 87.5 | 82.5 | 8 | 31.5 | 284+0.9/-0.2 | 38 | 68 | 180 | 538 413 | HPC-32-S |
| 50 | 138.5 | 131.5 | 23.4 | 48 | 400+1.7/-0.2 | 65 | 102 | 754 | 545 238 | HPC-50-S |
| 63 | 160.5 | 152.5 | 22 | 66 | 456+1.7/-0.2 | 75 | 133 | 1,138 | 545 239 | HPC-63-S |

Linear drives DGC

Accessories



Foot mounting HPC-SO
(when replacing linear drive DGPL
with linear drive DGC-GF/-KF)

Material:
Galvanised steel

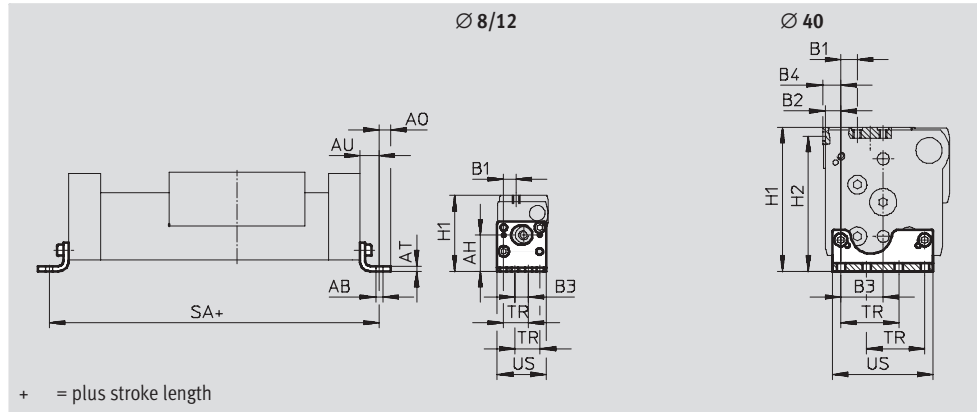

Dimensions and ordering data

| For Ø | AB Ø | AH | AO | AT | AU | B1 | B2 | B3 |
|-------|---------|------|-----|----|------|------|------|------|
| [mm] | | | | | | | | |
| 8 | 3.4 | 18.7 | 3 | 2 | 9 | 6.5 | – | 7 |
| 12 | 3.4 | 23.5 | 3 | 2 | 9 | 9.3 | – | 9.4 |
| 40 | 6.6 | – | 8.5 | 5 | 17.5 | 12.5 | 12.3 | 32.7 |

| For Ø | B4 | H1 | H2 | SA | TR | US | Weight | Part No. | Type |
|-------|------|-------|------|-----------|------|------|--------|----------|-----------|
| [mm] | | | | +0.9/–0.2 | ±0.1 | | [g] | | |
| 8 | – | 39 | – | 118 | 13 | 25.4 | 25 | 529 346 | HPC-8-SO |
| 12 | – | 47.5 | – | 143 | 18.6 | 33.8 | 42 | 529 348 | HPC-12-SO |
| 40 | 14.3 | 104.5 | 97.5 | 335 | 45 | 78 | 264 | 536 745 | HPC-40-SO |

Linear drives DGC

Accessories



Foot mounting HPC-SH
(when replacing linear drive DGPL
with linear drive DGC-GF/-KF)

Material:
Galvanised steel

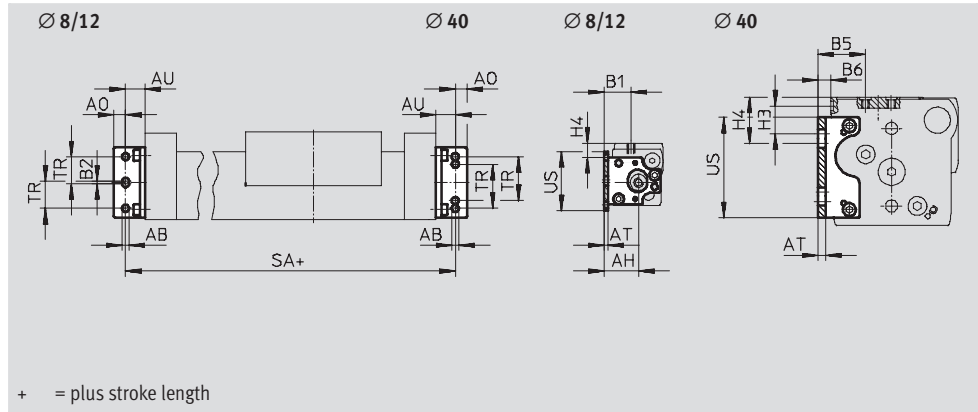

| Dimensions and ordering data | | | | | | | | |
|------------------------------|---------|------|-----|----|------|------|-----|----|
| For Ø | AB Ø | AH | AO | AT | AU | B1 | B2 | B5 |
| [mm] | | | | | | | | |
| 8 | 3.4 | 17.8 | 3 | 2 | 9 | 13.8 | 1.5 | - |
| 12 | 3.4 | 21.1 | 3 | 2 | 9 | 16.5 | 1.4 | - |
| 40 | 6.6 | - | 8.5 | 5 | 17.5 | - | - | 36 |

| For Ø | B6 | H3 | H4 | SA | TR | US | Weight | Part No. | Type |
|-------|-----|------|------|-----------|------|------|--------|----------|-----------|
| [mm] | | | | +0.9/-0.2 | ±0.1 | | [g] | | |
| 8 | - | - | 7.25 | 118 | 13 | 30.5 | 25 | 529 347 | HPC-8-SH |
| 12 | - | - | 4.5 | 143 | 18.6 | 41.8 | 41 | 529 349 | HPC-12-SH |
| 40 | 9.2 | 21.6 | 36 | 335 | 45 | 78 | 275 | 536 746 | HPC-40-SH |

Linear drives DGC

Accessories

FESTO

Profile mounting MUC
(order code: M)

Material:
High-alloy steel

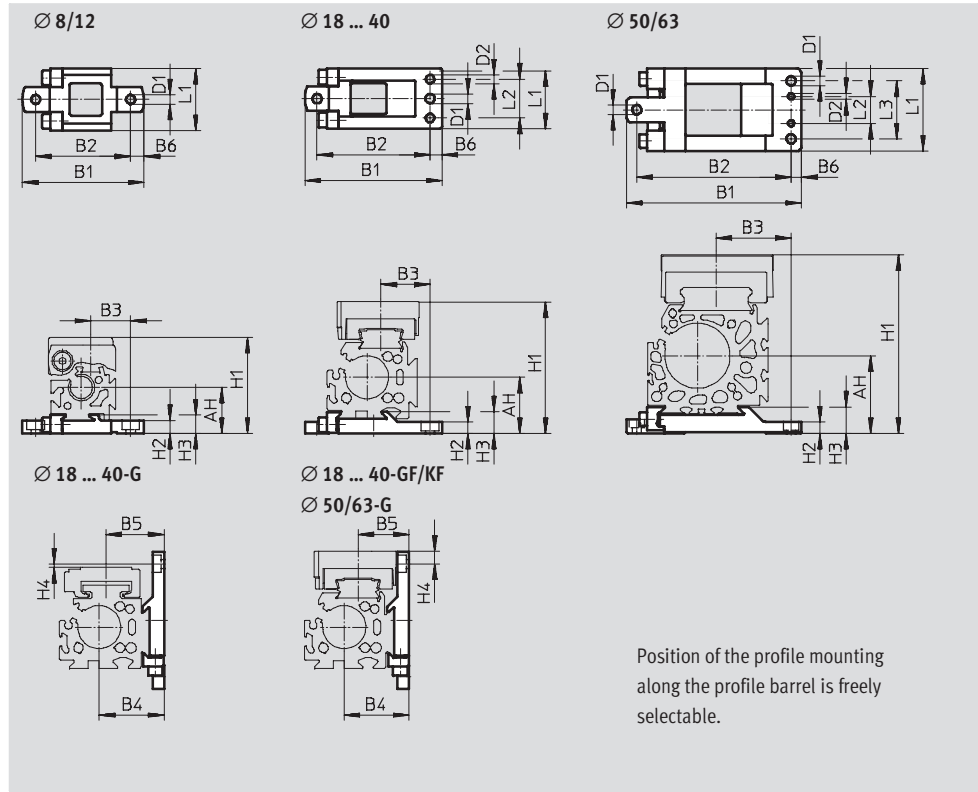

| Dimensions and ordering data | | | | | | |
|------------------------------|------|-----------|-----------|-------|-------|------|
| For Ø | AH | B1 | B2 | B3 | | B4 |
| [mm] | | | | G | GF/KF | |
| 8 | 17.7 | 47 | 36.7 | 15.35 | 15.35 | – |
| 12 | 18.5 | 52.5 | 42.2 | 16.5 | 16.5 | – |
| 18 | 27.2 | 67.8±0.2 | 56±0.15 | 30.5 | 28.7 | 27.2 |
| 25 | 32.5 | 79.5±0.2 | 65.5±0.15 | 32.5 | 28.5 | 37.5 |
| 32 | 37.5 | 94±0.2 | 80±0.15 | 35 | 35 | 47.5 |
| 40 | 47 | 110.5±0.2 | 96±0.15 | 43 | 43 | 57 |
| 50 | 61 | 145±0.5 | 125±0.2 | 56 | 56 | 77 |
| 63 | 75 | 169±0.5 | 149±0.2 | 72.5 | 72.5 | 87 |

| For Ø | B5 | | B6 | D1 | D2 | H1 | |
|-------|------|-------|-----|-----|----|------|-------|
| [mm] | G | GF/KF | | Ø | Ø | G | GF/KF |
| | | | | H13 | H7 | | |
| 8 | – | – | 5.1 | 3.5 | – | 37 | 37 |
| 12 | – | – | 5.1 | 3.5 | – | 42.5 | 42.5 |
| 18 | 25 | 23.2 | 5.7 | 5.5 | 5 | 57.5 | 64 |
| 25 | 33.5 | 29.5 | 7 | 5.5 | 5 | 67 | 76.5 |
| 32 | 37 | 37 | 7 | 5.5 | 5 | 82 | 87.5 |
| 40 | 46.8 | 46.8 | 7 | 6.5 | 6 | 100 | 111.5 |
| 50 | 61 | 61 | 7 | 9 | 6 | 137 | 141.5 |
| 63 | 69 | 69 | 10 | 9 | 6 | 159 | 172.5 |

Linear drives DGC

Accessories

FESTO

| Dimensions and ordering data | | | | | |
|------------------------------|---------------|----------------|------|-------|--------------|
| For Ø | H2 | H3 | H4 | | L1 |
| [mm] | | | G | GF/KF | |
| 8 | 5 | 7 | – | – | 24 |
| 12 | 4.5 | 7 | – | – | 24 |
| 18 | 5.7 $_{-0.2}$ | 9.9 ± 0.1 | 0.1 | 6.4 | 33 ± 0.1 |
| 25 | 6.5 $_{-0.2}$ | 12.5 ± 0.1 | 2.07 | 7.43 | 35 ± 0.1 |
| 32 | 6.5 $_{-0.2}$ | 13 ± 0.1 | 1.5 | 4 | 45 ± 0.1 |
| 40 | 8.5 $_{-0.2}$ | 16 ± 0.1 | 0.2 | 11.3 | 60 ± 0.1 |
| 50 | 11 | 23.5 | 4.7 | 9.2 | 80 ± 0.4 |
| 63 | 11 | 25.5 | 1.5 | 15 | 80 ± 0.4 |

| For Ø | L2 | L3 | Weight | Part No. | Type |
|-------|------------|-----------|--------|----------------|---------------|
| [mm] | ± 0.05 | ± 0.2 | [g] | | |
| 8 | – | – | 28 | 526 384 | MUC-8 |
| 12 | – | – | 32 | 526 387 | MUC-12 |
| 18 | 20.5 | – | 78 | 531 752 | MUC-18 |
| 25 | 22.5 | – | 113 | 531 753 | MUC-25 |
| 32 | 30 | – | 174 | 531 754 | MUC-32 |
| 40 | 44 | – | 346 | 531 755 | MUC-40 |
| 50 | 26 | 56 | 874 | 531 756 | MUC-50 |
| 63 | 26 | 56 | 1,080 | 531 757 | MUC-63 |

Linear drives DGC

Accessories

FESTO

Driver FK
(order code: FK)
for DGC-G

Materials:
Plate: Wrought aluminium alloy

Joint: Polyamide
Ball pin: High-alloy steel



For $\varnothing 8 \dots 40$

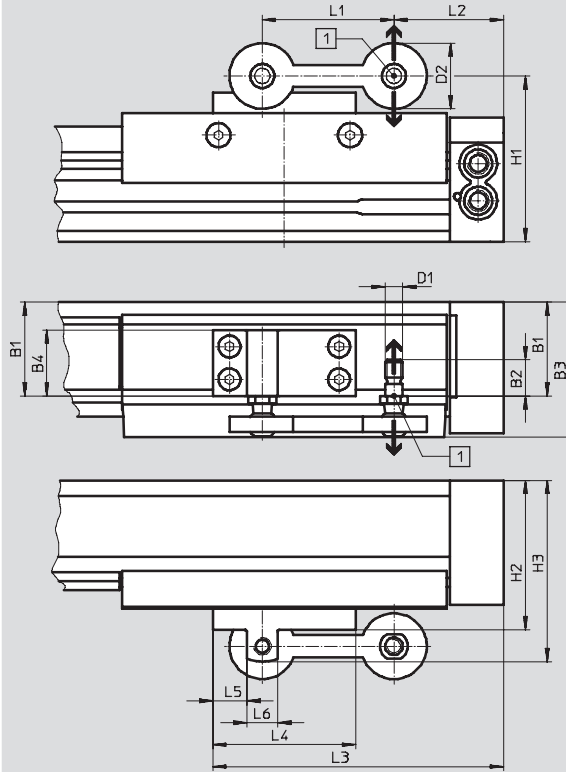

For $\varnothing 50/63$

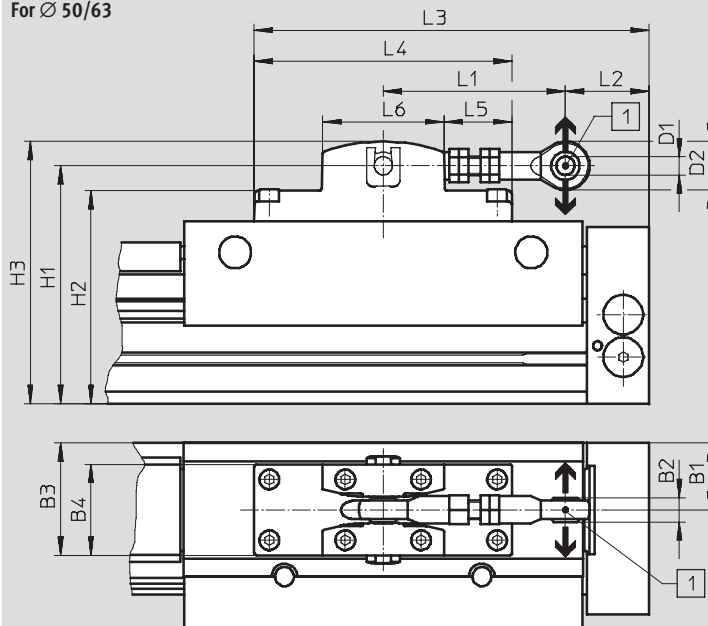

-  - Note

Compensation possible in direction of arrow.

- 1 Radial deflection:
with $\varnothing 8 \dots 40$: ± 2.5 mm
with $\varnothing 50/63$: ± 4 mm

Linear drives DGC

Accessories

FESTO

| Dimensions and ordering data | | | | |
|------------------------------|---|---|---------------|-----------------------------|
| For \varnothing [mm] | Max. offset between linear drive and external guide [mm] | Max. permissible load in direction of force | | Ambient temperature [°C] |
| | | [N] | | |
| 8 | ±2.5 | 550 | Backlash-free | -10 ... +60 |
| 12 | | 550 | Backlash-free | |
| 18 | | 1,400 | Backlash-free | |
| 25 | | 1,400 | Backlash-free | |
| 32 | | 1,400 | Backlash-free | |
| 40 | | 1,400 | Backlash-free | |
| 50 | ±4 | 5,000 | Low-backlash | |
| 63 | | 5,000 | Low-backlash | |

| For \varnothing [mm] | B1 | B2 | B3 | B4 | D1 | D2 | H1 | H2 | H3 | L1 |
|---------------------------|-------|------|-------|----|------------------|----|-------|-------|-------|-------------|
| 8 | 17.5 | 10.2 | 30 | 16 | M5 | 20 | 43.5 | 42 | 48 | 40 |
| 12 | 18.5 | 10.2 | 31 | 16 | M5 | 20 | 49 | 47.5 | 53.5 | 40 |
| 18 | 29.3 | 16.5 | 47.8 | 20 | M8 | 30 | 66.8 | 59.8 | 73.8 | 60 |
| 25 | 42.65 | 16.5 | 61.15 | 30 | M8 | 30 | 75.5 | 68 | 82.5 | 60 |
| 32 | 43 | 16.5 | 61.5 | 30 | M8 | 30 | 90 | 82.5 | 97 | 60 |
| 40 | 57.3 | 16.5 | 75.8 | 45 | M8 | 30 | 105 | 97.5 | 113 | 60 |
| 50 | 44 | 16 | 74 | 60 | 12 ^{H7} | 32 | 156.5 | 140 | 172.4 | 120 ... 125 |
| 63 | 50 | 16 | 80 | 60 | 12 ^{H7} | 32 | 176.5 | 161.5 | 192.4 | 120 ... 125 |

| For \varnothing [mm] | L2 | L3 | L4 | L5 | L6 | CRC ¹⁾ | Weight [g] | Part No. | Type |
|---------------------------|-----------|-------|-----|------|----|-------------------|---------------|----------|-----------|
| 8 | 5.1 | 62.6 | 35 | 13 | 9 | 1 | 29 | 529 350 | FKC-8/12 |
| 12 | 17.1 | 74.6 | 35 | 13 | 9 | 1 | 29 | 529 350 | FKC-8/12 |
| 18 | 24.5 | 107 | 65 | 15.5 | 14 | 1 | 97 | 538 714 | FKC-18 |
| 25 | 50 | 132.5 | 65 | 15.5 | 14 | 1 | 119 | 538 715 | FKC-25 |
| 32 | 77.5 | 162 | 75 | 17.5 | 14 | 1 | 122 | 538 961 | FKC-32 |
| 40 | 103 | 187.5 | 75 | 17.5 | 14 | 1 | 180 | 538 962 | FKC-40 |
| 50 | 50 ... 55 | 260 | 170 | 45 | 80 | 1 | 1,200 | 545 240 | FKC-50/63 |
| 63 | 75 ... 80 | 260 | 170 | 45 | 80 | 1 | 1,200 | 545 240 | FKC-50/63 |

1) Corrosion resistance class 1 to Festo standard 940 070
Components requiring low corrosion resistance. Transport and storage protection. Parts that do not have primarily decorative surface requirements, e.g. in internal areas that are not visible or behind covers

Linear drives DGC

Accessories



Shock absorber retainer DADP Stop KYC

(order code: YWZ1 or YWZ2)
For DGC-GF, DGC-KF, DGC-FA

Materials: Stop
Housing: Anodised aluminium
Stop bracket: Stainless steel casting
Clamp: High-alloy steel
Free of copper and PTFE

Materials: Shock absorber retainer
Housing: Anodised aluminium
Free of copper and PTFE

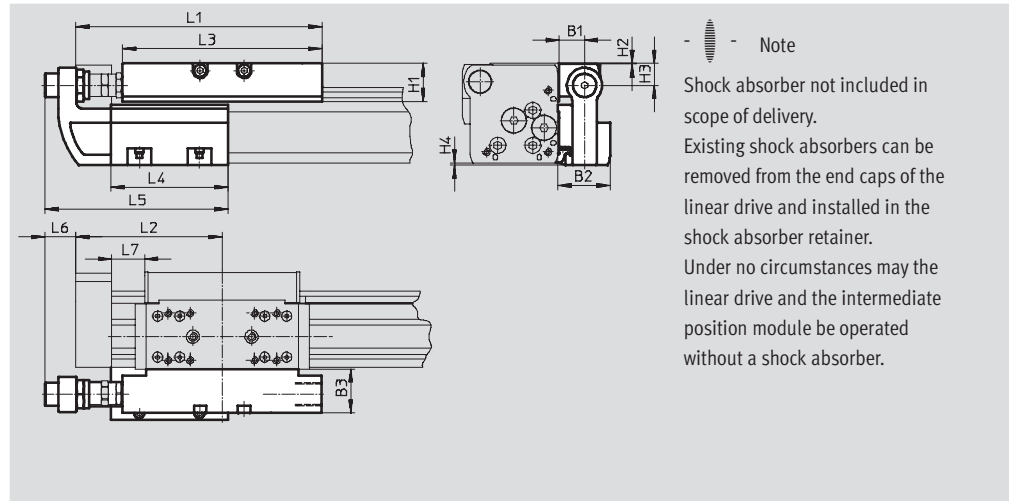

Note
Shock absorber not included in scope of delivery. Existing shock absorbers can be removed from the end caps of the linear drive and installed in the shock absorber retainer. Under no circumstances may the linear drive and the intermediate position module be operated without a shock absorber.

| Dimensions | | | | | | | | |
|------------|----|------|------|----|------|-----|------|-----|
| For Ø [mm] | | B1 | B2 | B3 | H1 | H2 | H3 | H4 |
| 18 | GF | 16 | 34.5 | 29 | 20.7 | 0.2 | 12.5 | 0.7 |
| | KF | | | | | | | |
| 25 | GF | 16.5 | 35 | 28 | 25.5 | 0.5 | 15 | 1.4 |
| | | | | KF | | | | |
| 32 | GF | 16.5 | 35 | 28 | 25.5 | 0.5 | 15 | 1.7 |
| | | | | KF | | | | |
| 40 | GF | 16 | 35.7 | 29 | 32 | 0.5 | 21.5 | 1.6 |
| | | | | KF | 35 | | | 37 |
| 50 | GF | 25 | 50 | 41 | 40.5 | 0.5 | 24 | 0 |
| | | | | | | | | |
| 63 | GF | 25 | 50 | 40 | 51.5 | 1.5 | 33 | 0 |
| | | | | | | | | |

| For Ø [mm] | | L1 | L2 | L3 | L4 | L5 | L6 | L7 min. |
|------------|----|-------|-------|-----|-----|-------|------|---------|
| 18 | GF | 128 | 74.5 | 107 | 80 | 118.5 | 23.5 | 14.5 |
| | | | | | | | | |
| 25 | GF | 168 | 100 | 136 | 80 | 125 | 20.5 | 22.5 |
| | | | | | | | | |
| 32 | GF | 206.8 | 124.8 | 164 | 120 | 165 | 14.5 | 42.8 |
| | | | | | | | | KF |
| 40 | GF | 255 | 150 | 210 | 156 | 220.5 | 31 | 30.8 |
| | | | | | | | | KF |
| 50 | GF | 301 | 175 | 252 | 170 | 238 | 27 | 31 |
| | | | | | | | | |
| 63 | GF | 328 | 200 | 256 | 200 | 268 | 24 | 41 |
| | | | | | | | | |

Linear drives DGC

Accessories

Technical data and ordering codes

Precision adjustment

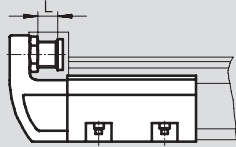

-  - Note

The stop KYC can be used in both directions.

Installation example

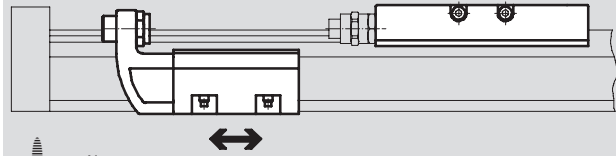

-  - Note

The stop KYC can be mounted at any position within the stroke.

| For \varnothing [mm] | Max. impact force [N] | Ambient temperature [°C] | CRC ¹⁾ | Weight [g] | Part No. | Type |
|--------------------------------|--------------------------|-----------------------------|-------------------|---------------|----------|----------------|
| Shock absorber retainer | | | | | | |
| 18 | GF | -10 ... +80 | 2 | 140 | 541 725 | DADP-DGC-18-GF |
| | KF | | | 130 | 541 729 | DADP-DGC-18-KF |
| 25 | GF | | | 205 | 541 726 | DADP-DGC-25-GF |
| | KF | | | 180 | 541 730 | DADP-DGC-25-KF |
| 32 | GF | | | 225 | 541 727 | DADP-DGC-32-GF |
| | KF | | | 215 | 541 731 | DADP-DGC-32-KF |
| 40 | GF | | | 380 | 541 728 | DADP-DGC-40-GF |
| | KF | | | 460 | 541 732 | DADP-DGC-40-KF |
| 50 | GF | | | 890 | 545 244 | DADP-DGC-50 |
| | KF | | | | | |
| 63 | GF | | | 1,080 | 545 245 | DADP-DGC-63 |
| | KF | | | | | |

1) Corrosion resistance class 2 to Festo standard 940 070

Components subject to moderate corrosion stress. Externally visible parts with primarily decorative surface requirements which are in direct contact with a normal industrial environment or media such as coolants or lubricating agents

| For \varnothing [mm] | Precision adjustment L [mm] | Ambient temperature [°C] | CRC ¹⁾ | Weight [g] | Part No. | Type |
|---------------------------|--------------------------------|-----------------------------|-------------------|---------------|----------|--------|
| Stop | | | | | | |
| 18 | 10 | -10 ... +80 | 2 | 400 | 541 691 | KYC-18 |
| 25 | 10 | | | 560 | 541 692 | KYC-25 |
| 32 | 10 | | | 790 | 541 693 | KYC-32 |
| 40 | 15 | | | 1,525 | 541 694 | KYC-40 |
| 50 | 15 | | | 2,270 | 545 242 | KYC-50 |
| 63 | 15 | | | 2,950 | 545 243 | KYC-63 |

1) Corrosion resistance class 2 to Festo standard 940 070

Components subject to moderate corrosion stress. Externally visible parts with primarily decorative surface requirements which are in direct contact with a normal industrial environment or media such as coolants or lubricating agents

Linear drives DGC

Accessories



Intermediate position module DADM

(order code: Z1, Z2 or Z3)

For DGC-KF

Materials:

Housing: Anodised aluminium

Stop screw, nut:

Galvanised steel

Clamp, lever:

High-alloy steel

Free of copper and PTFE

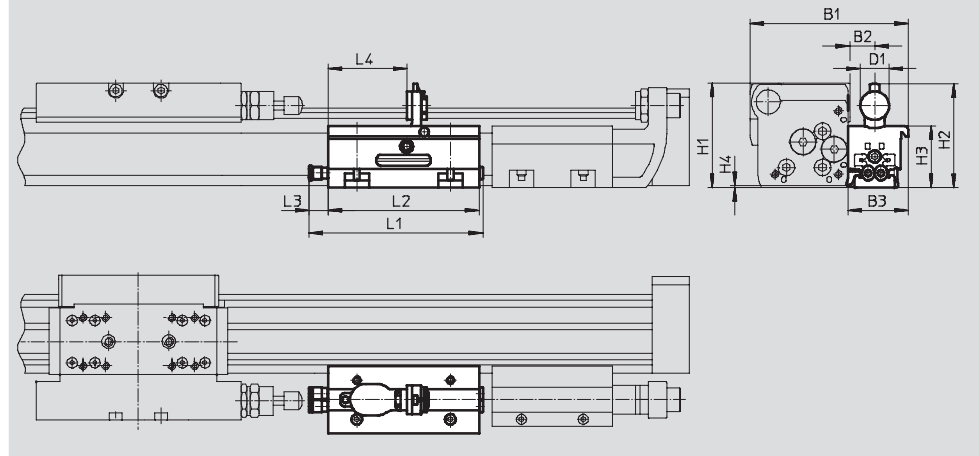

| Dimensions | | | | | | | | | | | | |
|------------|-------|------|----|----|-------|-------|----|-----|-----|-----|------|------|
| For Ø [mm] | B1 | B2 | B3 | D1 | H1 | H2 | H3 | H4 | L1 | L2 | L3 | L4 |
| 25 | 105 | 16.5 | 40 | 19 | 69.4 | 68.6 | 41 | 1.4 | 116 | 100 | 13.4 | 52.2 |
| 32 | 117.5 | 16.5 | 40 | 19 | 80.2 | 79.7 | 52 | 1.7 | 116 | 100 | 13.4 | 52.2 |
| 40 | 137.5 | 16 | 41 | 27 | 101.6 | 101.1 | 63 | 2.1 | 186 | 170 | 13.4 | 76.5 |

Minimum distance

between end stop and intermediate position

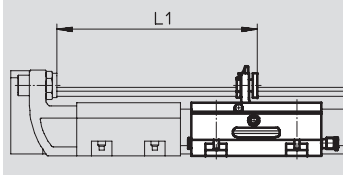

| For Ø [mm] | L1 |
|------------|-------|
| 25 | 145.3 |
| 32 | 185.3 |
| 40 | 271.5 |

between two intermediate positions

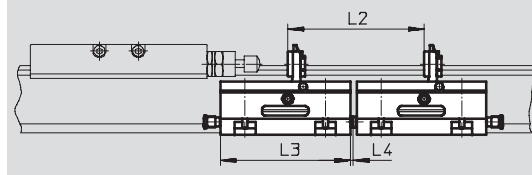

| For Ø [mm] | L2 | L3 | L4 |
|------------|-----|-----|-----|
| 25 | 105 | 100 | 2.5 |
| 32 | 105 | 100 | 2.5 |
| 40 | 175 | 170 | 2.5 |

 **Note**

- Shock absorber not included in scope of delivery. Existing shock absorbers can be removed from the end caps of the linear drive and installed in the shock absorber retainer. Under no circumstances may the linear drive and the intermediate position module be operated without a shock absorber.
- A shock absorber retainer DADP and a stop KYC are additionally needed when using an intermediate position module.
- The projection (dimension H4) must be noted when using the drive in combination with the intermediate position module DADM. Mounting via foot mountings HP or profile mountings MUC is recommended in this case.
- The position of the stop lever can be detected using proximity sensors SME/SMT-10 → 73.

Linear drives DGC

Accessories

Precision adjustment L

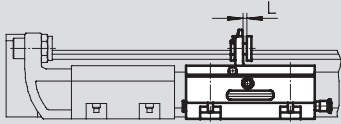

 - Note

The intermediate position module DADM can be used in both directions. A shock absorber retainer DADP and a stop KYC are additionally needed when using an intermediate position module.

Installation example

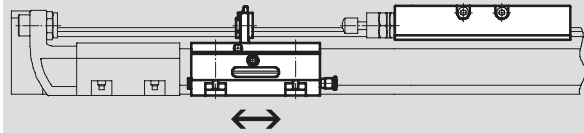

 - Note

The intermediate position module DADM can be mounted at any position within the stroke.

| Technical data | | | | |
|--|-------|---------------------------------|------|------|
| For Ø | [mm] | 25 | 32 | 40 |
| Pneumatic connection | | QS-4 | | |
| Operating pressure | [bar] | 2.5 ... 8 | | |
| Mounting position | | Any | | |
| Impact velocity | [m/s] | → 47 | | |
| Swivel time | [ms] | ≤100 | ≤100 | ≤300 |
| Precision adjustment L | [mm] | 2 | 2 | 4 |
| Repetition accuracy | [mm] | 0.02 | | |
| Position sensing | | For proximity sensor SME/SMT-10 | | |
| Weight | [g] | 430 | 530 | 970 |
| Ambient temperature | [°C] | -10 ... +60 | | |
| Corrosion resistance class CRC ¹⁾ | | 2 | | |
| Note on material | | Free of copper and PTFE | | |
| | | Conforms to RoHS | | |

1) Corrosion resistance class 2 to Festo standard 940 070
 Components subject to moderate corrosion stress. Externally visible parts with primarily decorative surface requirements which are in direct contact with a normal industrial environment or media such as coolants or lubricating agents.

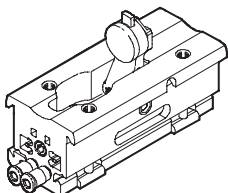

Ordering codes

| | For Ø [mm] | Part No. | Type |
|---|---------------|----------|---------------|
|  | 25 | 541 700 | DADM-DGC-25-A |
| | 32 | 541 701 | DADM-DGC-32-A |
| | 40 | 541 702 | DADM-DGC-40-A |

Linear drives DGC

Accessories

FESTO

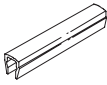
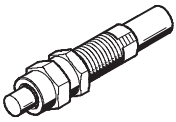
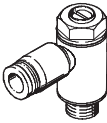
| Ordering data | | | | | | |
|--|-----------|---|------------|----------------|------------------|------------------|
| | For Ø | Remarks | Order code | Part No. | Type | PU ¹⁾ |
| Slot nut NST Technical data → Internet: hmbn | | | | | | |
|  | 25 ... 40 | For mounting slot | B | 547 264 | HMBN-5-1M5 | 10 |
| | 50, 63 | | | 186 566 | HMBN-5-2M5 | |
| Centring pin/sleeve ZBS/ZBH Technical data → Internet: zbs, zbh | | | | | | |
|  | 8 ... 18 | For slide | - | 150 928 | ZBS-5 | 10 |
| | 25 ... 63 | | | 150 927 | ZBH-9 | |
| | 8, 12 | For end cap | - | 525 273 | ZBS-2 | |
| | 18 | | | 150 928 | ZBS-5 | |
| | 25 ... 63 | | | 150 927 | ZBH-9 | |
| Slot cover ABP-S Technical data → Internet: abp | | | | | | |
|  | 18 ... 63 | For sensor slot each 0.5 m | L | 151 680 | ABP-5-S | 2 |
| Shock absorber YSRW Technical data → Internet: ysrw | | | | | | |
|  | 8 | For DGC basic version and recirculating ball bearing guide | YSRW | 540 344 | YSRW-DGC-8 | 1 |
| | 12 | | | 540 345 | YSRW-DGC-12 | |
| | 18 | | | 540 346 | YSRW-DGC-18-GF | |
| | 25 | | | 540 348 | YSRW-DGC-25-GF | |
| | 32 | | | 540 350 | YSRW-DGC-32-GF | |
| | 40 | 540 352 | | YSRW-DGC-40-GF | | |
| | 50 | 540 353 | | YSRW-DGC-40/50 | | |
| | 63 | 543 069 | | YSRW-DGC-63 | | |
| | 18 | For DGC with recirculating ball bearing guide | | 540 347 | YSRW-DGC-18-KF | |
| | 25 | | | 540 349 | YSRW-DGC-25-KF | |
| | 32 | | | 540 351 | YSRW-DGC-32-KF | |
| | 40 | | | 540 353 | YSRW-DGC-40/50 | |
| | 50 | | | | | |
| | 63 | | | 543 069 | YSRW-DGC-63 | |
| 63 | | | | | | |
| One-way flow control valve GRLA Technical data → Internet: grla | | | | | | |
|  | 8 ... 18 | Metal design | - | 193 137 | GRLA-M5-QS-3-D | 1 |
| | 25, 32 | | | 193 138 | GRLA-M5-QS-4-D | |
| | | | | 193 142 | GRLA-1/8-QS-3-D | |
| | | | | 193 143 | GRLA-1/8-QS-4-D | |
| | | | | 193 144 | GRLA-1/8-QS-6-D | |
| | | | | 193 145 | GRLA-1/8-QS-8-D | |
| | 40, 50 | | | 193 146 | GRLA-1/4-QS-6-D | |
| | | | | 193 147 | GRLA-1/4-QS-8-D | |
| | | | | 193 148 | GRLA-1/4-QS-10-D | |
| | 63 | | | 193 149 | GRLA-3/8-QS-6-D | |
| 193 150 | | GRLA-3/8-QS-8-D | | | | |
| | 193 151 | GRLA-3/8-QS-10-D | | | | |

1) Packaging unit quantity

Linear drives DGC

Accessories



FESTO

Proximity sensors for piston \varnothing 8/12 and intermediate position module DADM

| Ordering data – Proximity sensors for C-slot, magneto-resistive | | | | | | Technical data → Internet: smt |
|---|-----------------------------------|---------------|---|------------------|----------|--------------------------------|
| | Type of mounting | Switch output | Electrical connection, connection direction | Cable length [m] | Part No. | Type |
| N/O contact | | | | | | |
|  | Insertable in the slot lengthwise | PNP | Plug M8x1, 3-pin, in-line | 0.3 | 173 220 | SMT-10-PS-SL-LED-24 |
| | | | Cable, 3-wire, in-line | 2.5 | 173 218 | SMT-10-PS-KL-LED-24 |

| Ordering data – Proximity sensors for C-slot, magnetic reed | | | | | | Technical data → Internet: sme |
|---|-----------------------------------|---------------|---|------------------|----------|--------------------------------|
| | Type of mounting | Switch output | Electrical connection, connection direction | Cable length [m] | Part No. | Type |
| N/O contact | | | | | | |
|  | Insertable in the slot lengthwise | Contacting | Plug M8x1, 3-pin, in-line | 0.3 | 173 212 | SME-10-SL-LED-24 |
| | | | Cable, 3-wire, in-line | 2.5 | 173 210 | SME-10-KL-LED-24 |

Proximity sensors for piston \varnothing 18 ... 63



| Ordering data – Proximity sensors for T-slot, magneto-resistive | | | | | | Technical data → Internet: smt |
|---|--|---------------|-----------------------|-------------------------|----------|--------------------------------|
| | Type of mounting | Switch output | Electrical connection | Cable length [m] | Part No. | Type |
| N/O contact | | | | | | |
|  | Insertable in the slot from above, flush with cylinder profile | PNP | Cable, 3-wire | 2.5 | 543 867 | SMT-8M-PS-24V-K-2,5-OE |
| | | | Plug M8x1, 3-pin | 0.3 | 543 866 | SMT-8M-PS-24V-K-0,3-M8D |
| | | | Plug M12x1, 3-pin | 0.3 | 543 869 | SMT-8M-PS-24V-K-0,3-M12 |
| | | NPN | Cable, 3-wire | 2.5 | 543 870 | SMT-8M-NS-24V-K-2,5-OE |
| Plug M8x1, 3-pin | 0.3 | | 543 871 | SMT-8M-NS-24V-K-0,3-M8D | | |
|  | Insertable in the slot lengthwise, flush with the cylinder profile | PNP | Cable, 3-wire | 2.5 | 175 436 | SMT-8-PS-K-LED-24-B |
| | | | Plug M8x1, 3-pin | 0.3 | 175 484 | SMT-8-PS-S-LED-24-B |
| N/C contact | | | | | | |
|  | Insertable in the slot from above, flush with cylinder profile | PNP | Cable, 3-wire | 7.5 | 543 873 | SMT-8M-PO-24V-K7,5-OE |



Linear drives DGC

Accessories

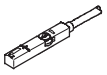
FESTO

Proximity sensors for piston $\varnothing 18 \dots 63$

| Ordering data – Proximity sensors for T-slot, magnetic reed | | | | | Technical data → Internet: sme | |
|---|--|---------------|-----------------------|------------------|--------------------------------|--------------------------------|
| | Type of mounting | Switch output | Electrical connection | Cable length [m] | Part No. | Type |
| N/O contact | | | | | | |
|  | Insertable in the slot from above, flush with cylinder profile | Contacting | Cable, 3-wire | 2.5 | 543 862 | SME-8M-DS-24V-K-2,5-0E |
| | | | | 5.0 | 543 863 | SME-8M-DS-24V-K-5,0-0E |
| | | | Cable, 3-wire | 2.5 | 543 872 | SME-8M-ZS-24V-K-2,5-0E |
| | | | Plug M8x1, 3-pin | 0.3 | 543 861 | SME-8M-DS-24V-K-0,3-M8D |
|  | Insertable in the slot lengthwise, flush with the cylinder profile | Contacting | Cable, 3-wire | 2.5 | 150 855 | SME-8-K-LED-24 |
| | | | Plug M8x1, 3-pin | 0.3 | 150 857 | SME-8-S-LED-24 |
| N/C contact | | | | | | |
|  | Insertable in the slot lengthwise, flush with the cylinder profile | Contacting | Cable, 3-wire | 7.5 | 160 251 | SME-8-O-K-LED-24 |

| Ordering data – Connecting cables | | | | Technical data → Internet: nebu | |
|---|-------------------------------|------------------------------|------------------|---------------------------------|-----------------------------|
| | Electrical connection, left | Electrical connection, right | Cable length [m] | Part No. | Type |
|  | Straight socket, M8x1, 3-pin | Cable, open end, 3-wire | 2.5 | 541 333 | NEBU-M8G3-K-2.5-LE3 |
| | | | 5 | 541 334 | NEBU-M8G3-K-5-LE3 |
| | Straight socket, M12x1, 5-pin | Cable, open end, 3-wire | 2.5 | 541 363 | NEBU-M12G5-K-2.5-LE3 |
| | | | 5 | 541 364 | NEBU-M12G5-K-5-LE3 |
|  | Angled socket, M8x1, 3-pin | Cable, open end, 3-wire | 2.5 | 541 338 | NEBU-M8W3-K-2.5-LE3 |
| | | | 5 | 541 341 | NEBU-M8W3-K-5-LE3 |
| | Angled socket, M12x1, 5-pin | Cable, open end, 3-wire | 2.5 | 541 367 | NEBU-M12W5-K-2.5-LE3 |
| | | | 5 | 541 370 | NEBU-M12W5-K-5-LE3 |