

Standard cylinders CDN, ISO 15552, Clean Design



Standard cylinders CDN, ISO 15552, Clean Design

Key features

Design



DIN



- Standards-based cylinders to ISO 15552 (corresponds to the withdrawn standards ISO 6431, DIN ISO 6431, VDMA 24 562, NF E 49 003.1 and UNI 10290)

Easy to clean

- Clean Design means smooth surfaces without slots and edges, which means fewer places where dirt can collect
- For hygiene reasons, the threads on the cylinder caps should be sealed with suitable blanking screws
- Resistant to conventional cleaning agents
- Increased corrosion protection

Easy to mount

- Comprehensive range of mounting accessories for just about every type of installation
- Contactless position sensing via proximity sensors

Flexible

- The variants can be configured according to individual needs thanks to the modular product system
- Greater flexibility thanks to the wide range of variants

Variants

Symbol	Key features	Description
	A3 Unlubricated operation	Cleaning processes degrease the piston rod. A special piston rod seal permits a longer service life compared to the standard seal.
	S2 Through piston rod	For working at both ends with the same force in the forward and return stroke, for attaching external stops.
	K2 Extended male piston rod thread	–
	K3 Female piston rod thread	–
	K8 Extended piston rod	–
	S6 Heat-resistant seals	Temperature resistance up to max. 120 °C. The seals used and the grease mean that this variant is not suitable for direct contact with foodstuffs.

CDN-...

- Ø 32 ... 100 mm
- Without position sensing

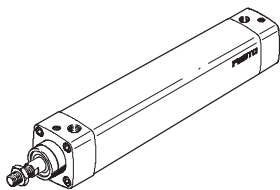

CDN-...-A...-R

- Ø 32 ... 100 mm
- With position sensing integrated in the end positions

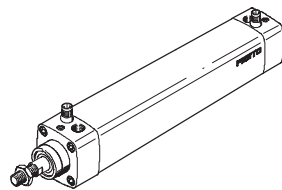

CDN-...-A-R

- Ø 32 ... 100 mm
- With sensor mounting rail for external position sensing

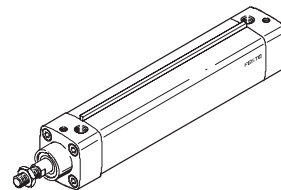

Note

A combination of integrated and external position sensing is possible.

Longer service life thanks to the bellows kit DADB



The bellows kit is a leak-free system. To prevent unwanted media being drawn in, the supply and exhaust air must be ducted via a venting hole in the connection part **1**.

The kit protects the piston rod, seal and bearings from a wide range of media, for example:

- dust,
- chips,
- oil,
- grease,
- fuel.

Standard cylinders CDN, ISO 15552, Clean Design

Peripherals overview

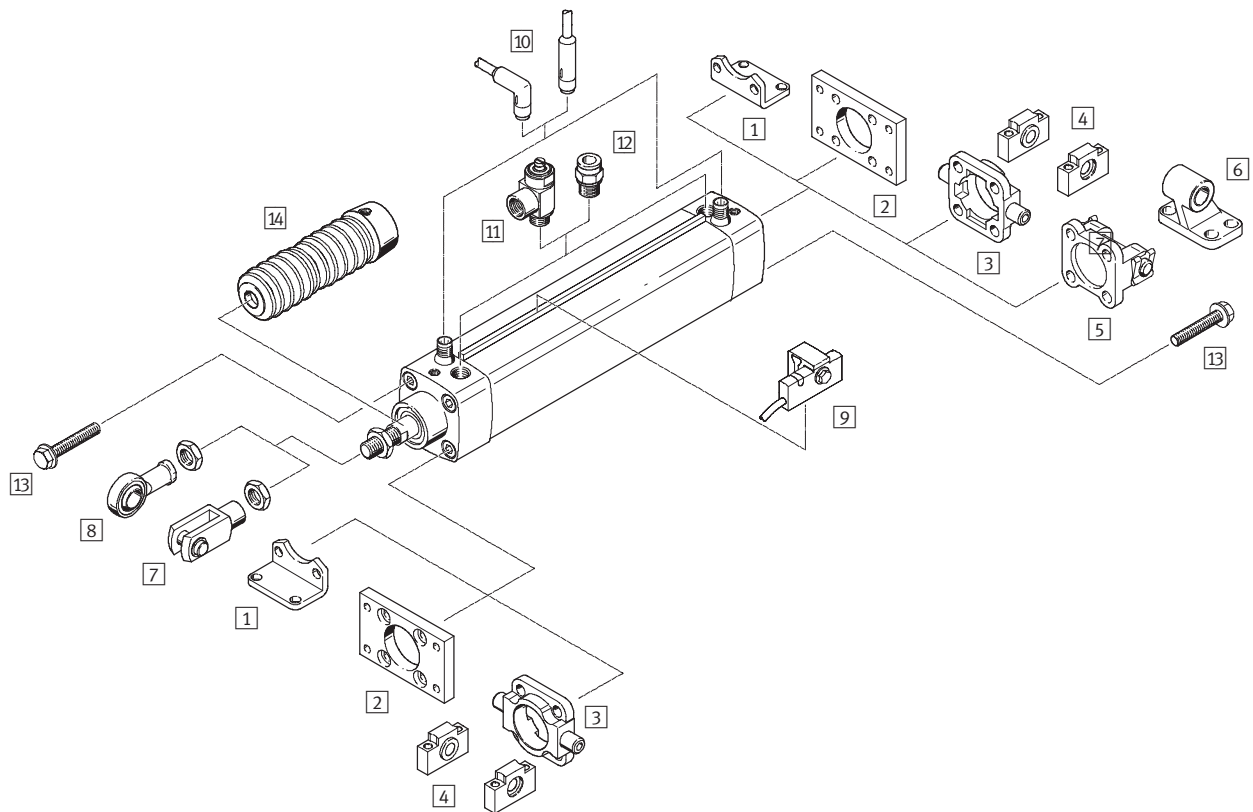

Mounting attachments and accessories		
	Brief description	→ Page/Internet
1	Foot mounting CRHNC	For bearing and end caps 17
2	Flange mounting CRFNG	– For bearing or end caps – Cannot be used on the bearing cap in combination with bellows kit DADB 17
3	Trunnion flange CRZNG	– For bearing or end caps in combination with trunnion supports CRLNZG – Cannot be used on the bearing cap in combination with bellows kit DADB 18
4	Trunnion supports CRLNZG	For swivel mounting CRZNG 18
5	Swivel flange SNCB- ... -R3	For end caps 19
6	Clevis foot CRLNG	For swivel flange SNCB- ...-R3 19
7	Rod clevis CRSG	Permits a swivelling movement of the cylinder in one plane 28
8	Rod eye CRSGS	With spherical bearing 28
9	Proximity sensor SMT-C1	For attachment to the sensor mounting rail 20
10	Plug socket with cable SIM-K- ... -CDN	– For electrical signal transmission and power supply – With food industry approval 22
11	One-way flow control valve CRGRLA	For regulating speed 28
12	Push-in fittings QS-F/QSL-F/CRQS/CRQSL	For connecting compressed air tubing with standard outside diameter 27
13	Blanking screws CR	For covering unused mounting threads 28
14	Bellows kit DADB	– Protects the cylinder (piston rod, seal and bearings) against a wide range of media and thus prevents premature wear – The kit can only be used in combination with an extended piston rod (K8) 23

Standard cylinders CDN, ISO 15552, Clean Design

Type codes

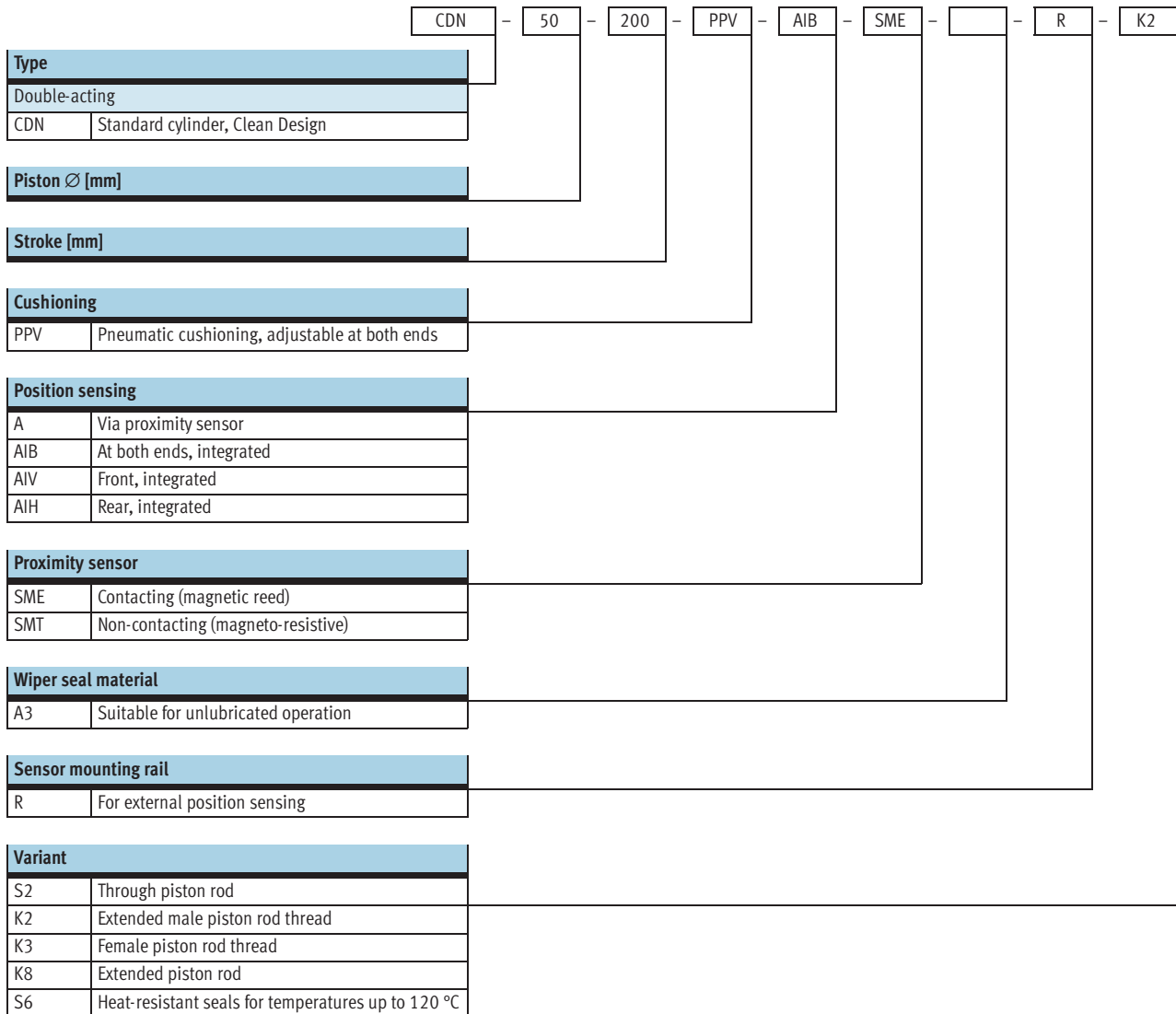

Standard cylinders CDN, ISO 15552, Clean Design

Technical data

Function

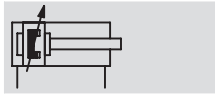

- Standards-based cylinders to ISO 15552 (corresponds to the withdrawn standards ISO 6431, DIN ISO 6431, VDMA 24 562, NF E 49 003.1 and UNI 10290)

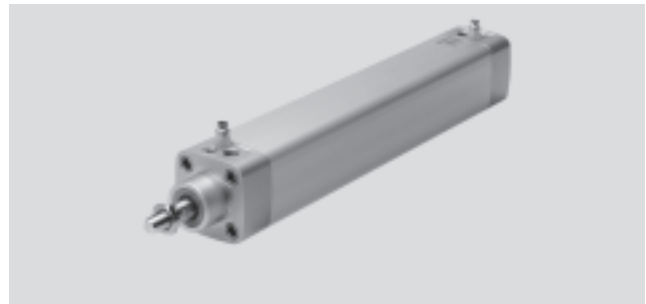

∅ - Diameter
32 ... 100 mm

— | — Stroke length
10 ... 2,000 mm

www.festo.com

Wearing parts kits

→ 9



General technical data							
Piston ∅	32	40	50	63	80	100	
Pneumatic connection	G $\frac{1}{8}$	G $\frac{1}{4}$	G $\frac{1}{4}$	G $\frac{3}{8}$	G $\frac{3}{8}$	G $\frac{1}{2}$	
Piston rod thread	M10x1.25	M12x1.25	M16x1.5	M16x1.5	M20x1.5	M20x1.5	
Constructional design	Piston						
	Piston rod						
	Cylinder barrel						
Cushioning	Pneumatic cushioning, adjustable at both ends						
Cushioning length [mm]	20	20	22	22	32	32	
Position sensing	A	Via proximity sensor					
	AIB	At both ends, integrated					
	AIV	Front, integrated					
	AIH	Rear, integrated					
Type of mounting	Via female thread						
	Via accessories						
Mounting position	Any						

Operating and environmental conditions		
Operating medium	Filtered compressed air, lubricated or unlubricated	
Operating pressure [bar]	0.6 ... 12	
Ambient temperature ¹⁾ [°C]	-20 ... +80	
S6 [°C]	0 ... +120	
Corrosion resistance class CRC ²⁾	3	

1) Note operating range of proximity sensors.

2) Corrosion resistance class 3 as per Festo standard 940 070

Components requiring higher corrosion resistance. External visible parts in direct contact with industrial atmospheres or media such as solvents and cleaning agents, with a predominantly functional requirement for the surface.

Standard cylinders CDN, ISO 15552, Clean Design

Technical data

Forces [N] and impact energy [J]						
Piston Ø	32	40	50	63	80	100
Theoretical force at 6 bar, advancing	483	754	1,178	1,870	3,016	4,712
Theoretical force at 6 bar, retracting	415	633	990	1,682	2,721	4,418
Max. impact energy at the end positions		0.4	0.7	1.0	1.3	1.6
	S6	0.2	0.35	0.5	0.65	0.8

Permissible impact velocity:
$$v_{perm.} = \sqrt{\frac{2 \times E_{perm.}}{m_{dead} + m_{load}}}$$

Maximum permissible load:
$$m_{load} = \frac{2 \times E_{perm.}}{v^2} - m_{dead}$$

$v_{perm.}$ Permissible impact velocity
 $E_{perm.}$ Max. impact energy
 $m_{intrinsic}$ Moving load (drive)
 m_{load} Moving effective load

Note
 This data represents the maximum values that can be achieved. The maximum permissible impact energy must be observed.

Max. lateral force Fq as a function of stroke length l

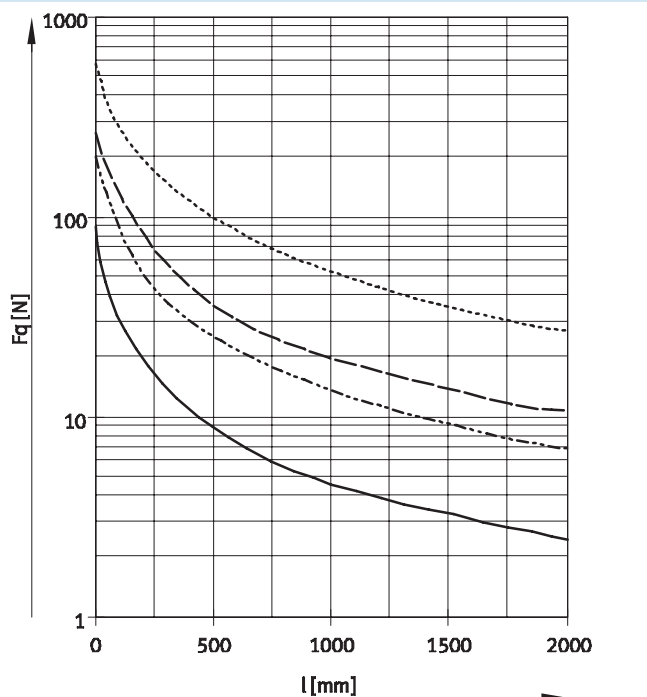
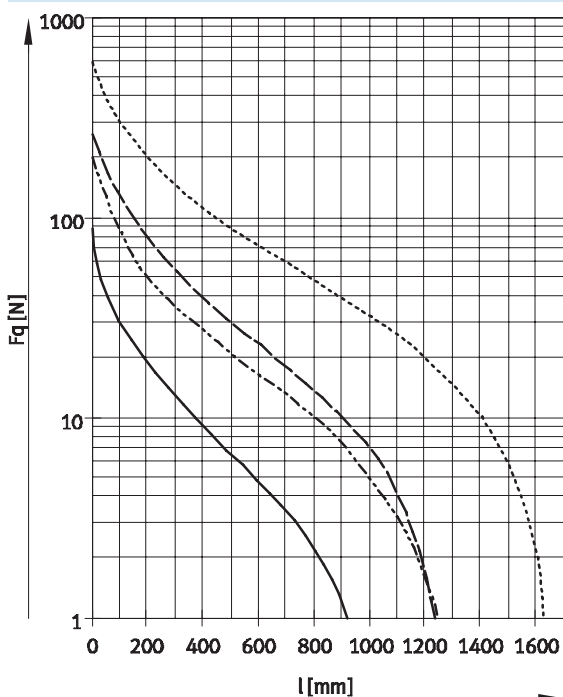

- Ø 32
- - - - Ø 40
- · - · Ø 50, 63
- · · · · Ø 80, 100

Standard cylinders CDN, ISO 15552, Clean Design

Technical data

Weight [g]						
Piston Ø	32	40	50	63	80	100
Basic version						
Product weight with 0 mm stroke	600	920	1,530	2,140	3,151	4,820
Additional weight per 10 mm stroke	33	42	65	70	137	158
Moving load with 0 mm stroke						
Product weight with 0 mm stroke	130	250	450	510	1,131	1,544
Additional load per 10 mm stroke	9	16	25	25	137	158
S2 – Through piston rod						
Product weight with 0 mm stroke	715	1,130	1,920	2,570	3,613	5,389
Additional weight per 10 mm stroke	42	58	90	95	175	196
Moving load with 0 mm stroke						
Product weight with 0 mm stroke	210	420	780	860	1,392	1,872
Additional load per 10 mm stroke	18	32	50	50	76	76

Materials

Sectional view

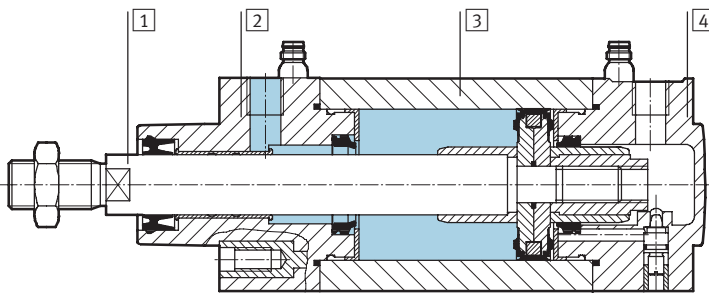

Standard cylinder	Basic version	S6	A3
1 Piston rod	High-alloy steel		
2 Bearing cap	Anodised aluminium		
3 Cylinder barrel	Anodised aluminium		
4 End cap	Die-cast aluminium		
- Seals	Polyurethane, nitrile rubber	Fluoro rubber	Polyethylene
- Note on materials	Free of copper and PTFE		

Standard cylinders CDN, ISO 15552, Clean Design

Technical data

FESTO

Dimensions

Download CAD data → www.festo.com

Basic version

and A3 – unlubricated operation

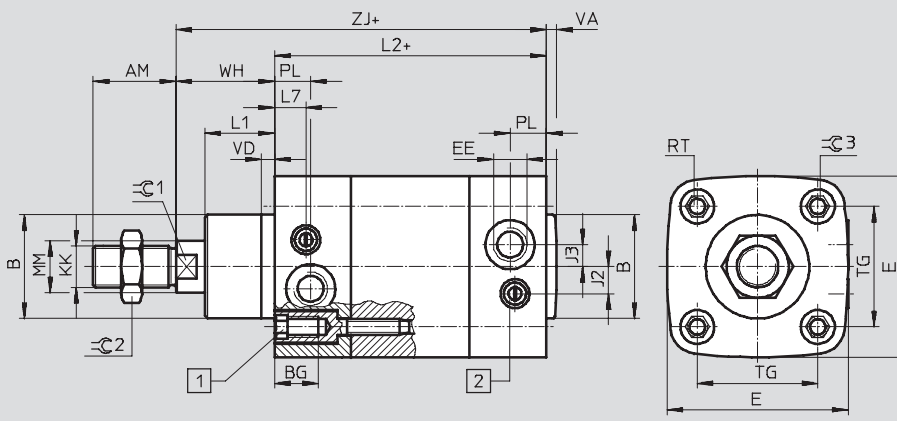

- 1 Socket head screw with female thread for mounting attachments
- 2 Regulating screw for adjustable end position cushioning

With position sensing integrated in the end positions

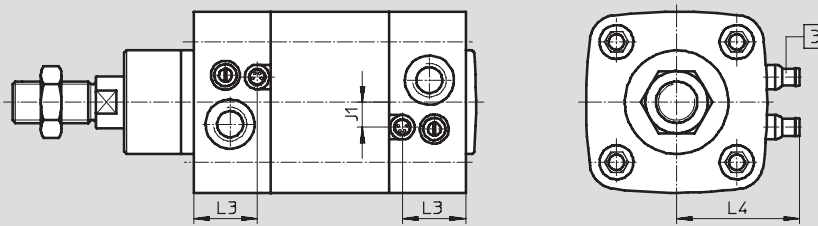

- 3 Miniature plug connector, 3-pin, with integrated proximity sensor (order code SME or SMT) suitable for plug socket with cable SIM-K...-CDN

With sensor mounting rail for external position sensing

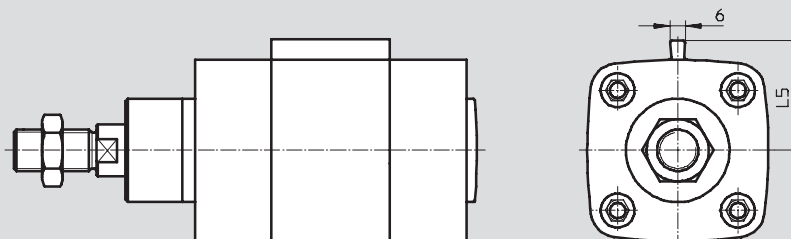

∅	AM	B	BG	E	EE	J1	J2	J3	KK	L1	L2	L3	L4
[mm]		∅ d11	min.										±2
32	22	30	16	50	G ¹ / ₈	6	6	5.5	M10x1.25	18	94 ±0.4	23.2	35
40	24	35	16	58	G ¹ / ₄	8.5	8.4	6.5	M12x1.25	21	105 ±0.4	28.2	39
50	32	40	17	70	G ¹ / ₄	9	9	8.5	M16x1.5	28	106 ±0.4	28.2	45
63	32	45	17	81	G ³ / ₈	14	14	11	M16x1.5	28.5	121 ±0.4	35.7	50
80	40	45	17	100	G ³ / ₈	21.5	14.5	8	M20x1.5	34.5	128 ±0.8	30.6	60
100	40	55	17	120	G ¹ / ₂	22	16	17.5	M20x1.5	38	138 ±1	33.5	70

∅	L5	L7	MM	PL	RT	TG	VA	VD	WH	ZJ	∅C1	∅C2	∅C3
[mm]			∅						±1.4				
32	30	10.5	12	17	M6	32.5	4	5	26	120	10	17	6
40	34	16	16	22	M6	38	4	5	30	135	13	19	6
50	40	12	20	20	M8	46.5	4	5	37	143	17	24	8
63	45.5	17.5	20	26	M8	56.5	4	5	37	158	17	24	8
80	55	15.4	25	16.4	M10	72	4	5	46	174	22	30	6
100	65	15.8	25	19	M10	89	4	5	51	189	22	30	6

Standard cylinders CDN, ISO 15552, Clean Design

Technical data

Dimensions – Variants

Download CAD data → www.festo.com

K2 – Extended male piston rod thread

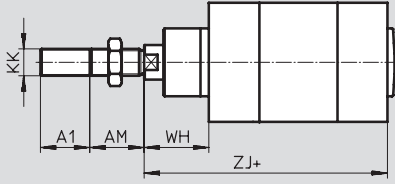

+ = plus stroke length

K3 – Female piston rod thread

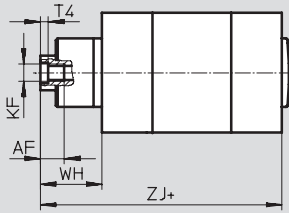

+ = plus stroke length

K8 – Extended piston rod

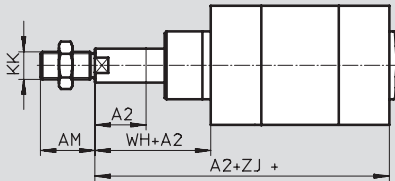

+ = plus stroke length

S2 – Through piston rod

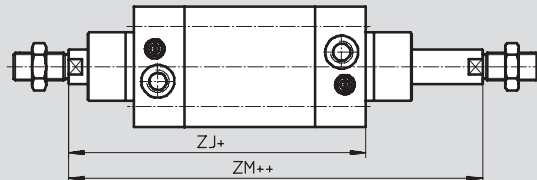

+ = plus stroke length

++ = plus 2x stroke length

∅	AF	AM	A1	A2	KF	KK	T4	WH	ZJ	ZM
[mm]			max.	max.				±1.4		
32	12	22	35	500	M6	M10x1.25	2.6	26	120	146.6
40	12	24	35		M8	M12x1.25	3.3	30	135	165.3
50	16	32	70		M10	M16x1.5	4.7	37	143	180.3
63	16	32	70		M10	M16x1.5	4.7	37	158	195.9
80	20	40	70		M12	M20x1.5	6.1	46	174	222
100	20	40	70		M12	M20x1.5	6.1	51	189	240

Ordering data – Wearing parts kits

Piston ∅ [mm]	Part No.	Type	Piston ∅ [mm]	Part No.	Type
32	397 440	CDN-32-...-PPV-A ¹⁾	63	397 443	CDN-63-...-PPV-A ¹⁾
40	397 441	CDN-40-...-PPV-A ¹⁾	80	397 444	CDN-80-...-PPV-A ¹⁾
50	397 442	CDN-50-...-PPV-A ¹⁾	100	397 445	CDN-100-...-PPV-A ¹⁾

1) Assembly grease included in scope of delivery

Standard cylinders CDN, ISO 15552, Clean Design

Technical data

Magnetic reed proximity sensor (order code SME)

Material:

Housing: Polyamide, epoxy resin,
nickel-plated brass

Plug contacts: Gold-plated brass

Free of copper and PTFE



Note

The proximity sensor can only be ordered in conjunction with the order code AIB, AIV and AIH (integrated position sensing) in the modular product system.



Design	
Constructional design	Integrated
Switching element function	N/O contact
Switching output	Contacting, bipolar
Switching status display	Yellow LED

Technical data – N/O contact		
Measuring principle	Magnetic reed	
Electrical connection	Plug M8x1, 3-pin	
Operating voltage range	[V DC]	12 ... 30
	[V AC]	12 ... 30
Max. output current	[mA]	500
Max. switching capacity	[W]	10
Voltage drop	[V]	< 2
Residual current	[mA]	0
Switch-on time	[ms]	0.5
Switch-off time	[ms]	0.5
Reproducibility of switching point	[mm]	±0.1
Protection against short circuit		No
Protection against overloading		No
Protection against polarity reversal		No
Product weight	[g]	2.7
Protection class		IP65, IP67
		IP69K only in combination with SIM-K-...-CDN

Operating and environmental conditions		
Ambient temperature	[°C]	-20 ... +60
Corrosion resistance class CRC ¹⁾		3
CE mark (see declaration of conformity)		To EU EMC Directive

1) Corrosion resistance class 3 as per Festo standard 940 070

Components requiring higher corrosion resistance. External visible parts in direct contact with industrial atmospheres or media such as solvents and cleaning agents, with a predominantly functional requirement for the surface.

Standard cylinders CDN, ISO 15552, Clean Design

Technical data

Magneto-resistive proximity sensor
(order code SMT)

Material:

Housing: Polyamide, epoxy resin,
nickel-plated brass
Plug contacts: Gold-plated brass
Free of copper and PTFE

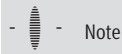

Note

The proximity sensor can only be ordered in conjunction with the order code AIB, AIV and AIH (integrated position sensing) in the modular product system.



Design	
Constructional design	Integrated
Switching element function	N/O contact
Switching output	Non-contacting, bipolar
Switching status display	Yellow LED

Technical data – N/O contact	
Measuring principle	Magneto-resistive
Electrical connection	Plug, M8x1, 3-pin
Operating voltage range	[V DC] 5 ... 30
Max. output current	[mA] 100
Max. switching capacity	[W] 3
Voltage drop	[V] < 2
Residual current	[µA] 10
Switch-on time	[ms] 0.5
Switch-off time	[ms] 0.5
Reproducibility of switching point	[mm] ±0.1
Protection against short circuit	Yes
Protection against overloading	Yes
Protection against polarity reversal	Yes
Product weight	[g] 2.7
Protection class	IP65, IP67
	IP69K only in combination with SIM-K-...-CDN

Operating and environmental conditions	
Ambient temperature	[°C] -20 ... +60
Corrosion resistance class CRC ¹⁾	3
CE mark (see declaration of conformity)	To EU EMC Directive

1) Corrosion resistance class 3 as per Festo standard 940 070
Components requiring higher corrosion resistance. External visible parts in direct contact with industrial atmospheres or media such as solvents and cleaning agents, with a predominantly functional requirement for the surface.

Standard cylinders CDN, ISO 15552, Clean Design

Technical data

Proximity sensor,
magnetic reed
(order code SME)

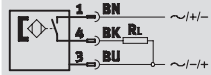

Note

The proximity sensor can only be ordered in conjunction with the order code AIB, AIV and AIH (integrated position sensing) in the modular product system.



Technical data		
General information		
Design	Integrated	
Based on standard	DIN EN 60947-5-2	
CE mark (see declaration of conformity)	To EU EMC Directive	
Note on materials	Free of copper and PTFE	
Input signal/measuring element		
Measuring principle	Magnetic reed	
Ambient temperature	[°C]	-20 ... +60
Switching output		
Switching output	Contacting, bipolar	
Switching element function	N/O contact	
Reproducibility of switching point	[mm]	±0.1
Hysteresis	[mm]	1 ... 4, depending on the cylinder used
Switch-on time	[ms]	0.5
Switch-off time	[ms]	0.5
Max. output current	[mA]	500
Max. switching capacity AC	[W]	10 VA
Max. switching capacity DC	[W]	10 W
Inductive protective circuit	Adapted to MZ coil with LED	
Residual current	[mA]	0
Output, further data		
Protection against short circuit	No	
Protection against overloading	No	
Electronic components		
Operating voltage range	[V AC]	12 ... 30
	[V DC]	12 ... 30
Protection against polarity reversal	No	
Electromechanical components		
Electrical connection	Plug, M8x1, 3-pin	
Connection direction	Lateral	
Information on crimp connector materials	Gold-plated brass	

Standard cylinders CDN, ISO 15552, Clean Design

Technical data

Technical data		
Mechanical components		
Tightening torque	[Nm]	0.3
Mounting position		Any
Product weight	[g]	2.7
Information on housing materials		Polyamide, epoxy resin, nickel-plated brass
Display/operation		
Switching status display		Yellow LED
Immissions/emissions		
Degree of protection		IP65, IP67 to IEC 60529
		IP69K, to DIN 40050 Part 9
		Only in conjunction with plug socket with cable SIM-K...-CDN
Corrosion resistance class CRC ¹⁾		3

1) Corrosion resistance class 3 according to Festo standard 940 070
 Components subject to high corrosion stress. External visible parts in direct contact with industrial atmospheres or media such as solvents and cleaning agents, with a predominantly functional requirement for the surface.

Standard cylinders CDN, ISO 15552, Clean Design

Technical data

Proximity sensor,
magneto-resistive
(order code SMT)

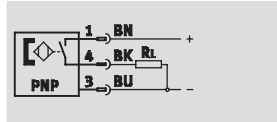

-  Note

The proximity sensor can only be ordered in conjunction with the order code AIB, AIV and AIH (integrated position sensing) in the modular product system.



Technical data		
General information		
Design	Integrated	
Based on standard	DIN EN 60947-5-2	
CE mark (see declaration of conformity)	To EU EMC Directive	
Note on materials	Free of copper and PTFE	
Input signal/measuring element		
Measuring principle	Magneto-resistive	
Ambient temperature	[°C]	-20 ... +60
Switching output		
Switching output	PNP	
Switching element function	N/O contact	
Reproducibility of switching point	[mm]	±0.1
Hysteresis	[mm]	1 ... 4, depending on the cylinder used
Switch-on time	[ms]	0.5
Switch-off time	[ms]	0.5
Max. output current	[mA]	100
Max. switching capacity DC	[W]	3
Voltage drop	[V]	< 2
Inductive protective circuit	Adapted to MZ, MY, ME coils	
Residual current	[µA]	< 10
Output, further data		
Protection against short circuit	Yes	
Protection against overloading	Yes	
Electronic components		
Operating voltage range	[V DC]	5 ... 30
Residual ripple	[%]	10
Protection against polarity reversal	Yes	
Electromechanical components		
Electrical connection	Plug, M8x1, 3-pin	
Connection direction	Lateral	
Information on crimp connector materials	Gold-plated brass	

Standard cylinders CDN, ISO 15552, Clean Design

Technical data

Technical data		
Mechanical components		
Tightening torque	[Nm]	0.3
Mounting position		Any
Product weight	[g]	2.7
Information on housing materials		Polyamide, epoxy resin, nickel-plated brass
Display/operation		
Switching status display		Yellow LED
Immissions/emissions		
Degree of protection		IP65, IP67 to IEC 60529
		IP69K, to DIN 40050 Part 9
		Only in conjunction with plug socket with cable SIM-K...-CDN
Corrosion resistance class CRC ¹⁾		3

1) Corrosion resistance class 3 according to Festo standard 940 070
 Components subject to high corrosion stress. External visible parts in direct contact with industrial atmospheres or media such as solvents and cleaning agents, with a predominantly functional requirement for the surface.

Standard cylinders CDN, ISO 15552, Clean Design

Ordering data – Modular products

M Mandatory data				O Options									
Module No.	Function	Stroke		Position sensing		Wiper seal material		Type of piston rod		Female thread		Temperature resistance	
	Piston Ø	Cushioning		Proximity sensor		Sensor mounting rail		Extended male thread		Extended piston rod			
193 660	CDN	32	10 ...	PPV	A	SME	A3	R	S2	...K2	K3	...K8	S6
193 661		40	2 000		AIB	SMT							
193 662		50			AIV								
193 663		63			AIH								
193 664		80											
193 665		100											
Order example													
193 663	CDN	- 63	- 900	- PPV	- AIV	- SME	-	-	-	- 30K2	-	-	-

Ordering table										
Size	32	40	50	63	80	100	Condi- tions	Code	Enter code	
M Module No.	193 660	193 661	193 662	193 663	193 664	193 665				
Function	Standard cylinder, double-acting, based on ISO 15552 (Clean Design)							CDN		CDN
Piston Ø [mm]	32	40	50	63	80	100		...		
Stroke [mm]	10 ... 2 000								...	
Cushioning	Pneumatic cushioning, adjustable at both ends								-PPV	-PPV
O Position sensing	Via proximity sensor							1	-A	
	At both ends, integrated							2	-AIB	
	Front, integrated							2	-AIV	
	Rear, integrated							2	-AIH	
Proximity sensor	SME (contacting)							3	-SME	
	SMT (non-contacting)							3	-SMT	
Wiper seal material	Suitable for unlubricated operation							4	-A3	
Sensor mounting rail	Sensor mounting rail for external position sensing							5	-R	
Type of piston rod	Through piston rod								-S2	
Extended male thread [mm]	Piston rod with extended male thread									
	1 ... 35			1 ... 70					...K2	
Female thread	Piston rod with female thread									
	(M6)	(M8)	(M10)	(M12)			6	-K3		
Extended piston rod [mm]	Extended piston rod at front									
	1 ... 500								...K8	
Temperature resistance	Heat-resistant seals for temperatures up to 120 °C							7	-S6	

- 1 A Only with sensor rail R
- 2 AIB, AIV, AIH Only with proximity sensor SME or SMT
- 3 SME, SMT Only with position sensing AIB, AIV or AIH
- 4 A3 Not with temperature resistance S6
Not with position sensing AIB, AIV or AIH
- 5 R Only with position sensing A, AIB, AIV or AIH
- 6 K3 Not with extended male thread K2
- 7 S6 Not with position sensing A, AIB, AIV or AIH

Transfer order code

- - - - - - - - - - - - - -

Standard cylinders CDN, ISO 15552, Clean Design



Accessories

Foot mounting CRHNC

Material:
High-alloy steel
Free of copper, PTFE and silicone

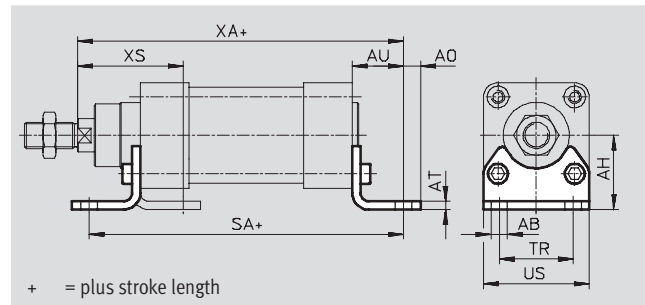

Dimensions and ordering data														
For Ø	AB Ø	AH	AO	AT	AU	SA	TR	US	XA	XS	CRC ¹⁾	Weight	Part No.	Type
[mm]												[g]		
32	7	32	6.5	4	24	142	32	45	144.7	45.7	4	135	176 937	CRHNC-32
40	10	36	9	4	28	160.8	36	54	163.6	53.8	4	180	176 938	CRHNC-40
50	10	45	9.5	5	31	167.9	45	64	175	63.1	4	325	176 939	CRHNC-50
63	10	50	12.5	5	32	184.9	50	75	191.5	64.6	4	405	176 940	CRHNC-63
80	12	63	15	6	41	209.9	63	93	215.5	81.6	4	820	176 941	CRHNC-80
100	14.5	71	17.5	6	41	220.1	75	110	229.6	85.5	4	1,000	176 942	CRHNC-100

1) Corrosion resistance class 4 according to Festo standard 940 070
Components subject to particularly high corrosion stress. Parts used with aggressive media, e.g. in the food or chemical industry. These applications should be supported with special tests with the media if required.

Flange mounting CRFNG

Material:
High-alloy steel
Free of copper, PTFE and silicone

Cannot be used on the bearing cap in conjunction with bellows kit DADB.

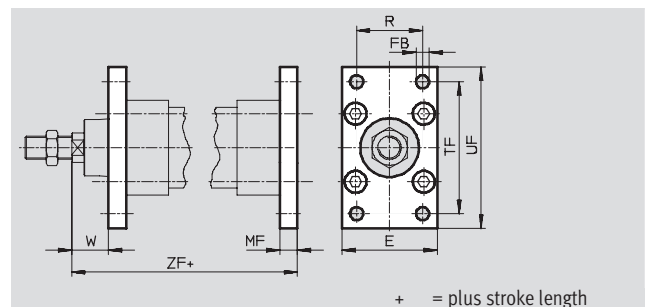
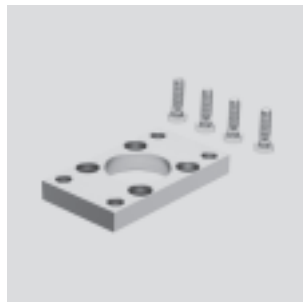

Dimensions and ordering data														
For Ø	E	FB Ø	MF	R	TF	UF	W	ZF	CRC ¹⁾	Weight	Part No.	Type		
[mm]										[g]				
32	45	7	10	32	64	80	16	130	4	240	161 846	CRFNG-32		
40	54	9	10	36	72	90	20	145	4	300	161 847	CRFNG-40		
50	65	9	12	45	90	110	25	155	4	550	161 848	CRFNG-50		
63	75	9	12	50	100	120	25	170	4	710	161 849	CRFNG-63		
80	93	12	16	63	126	150	30	190	4	1,680	161 850	CRFNG-80		
100	110	14	16	75	150	175	35	205	4	2,450	161 851	CRFNG-100		

1) Corrosion resistance class 4 according to Festo standard 940 070
Components subject to particularly high corrosion stress. Parts used with aggressive media, e.g. in the food or chemical industry. These applications should be supported with special tests with the media if required.

Standard cylinders CDN, ISO 15552, Clean Design



Accessories

Trunnion flange CRZNG

Material:

High-alloy steel

Free of copper, PTFE and silicone

Cannot be used on the bearing cap in conjunction with bellows kit DADB.

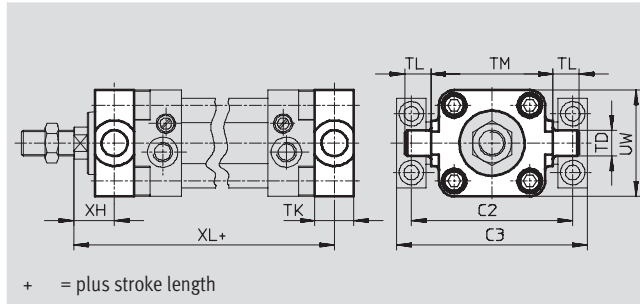

Dimensions and ordering data													
For \varnothing	C2	C3	TD	TK	TL	TM	UW	XH	XL	CRC ¹⁾	Weight	Part No.	Type
[mm]			\varnothing e9								[g]		
32	71	86	12	16	12	50	50	18	128	4	150	161 852	CRZNG-32
40	87	105	16	20	16	63	55	20	145	4	260	161 853	CRZNG-40
50	99	117	16	24	16	75	65	25	155	4	430	161 854	CRZNG-50
63	116	136	20	24	20	90	75	25	170	4	640	161 855	CRZNG-63
80	136	156	20	28	20	110	100	32	188	4	1,300	161 856	CRZNG-80
100	164	189	25	38	25	132	120	32	208	4	2,400	161 857	CRZNG-100

1) Corrosion resistance class 4 according to Festo standard 940 070

Components subject to particularly high corrosion stress. Parts used with aggressive media, e.g. in the food or chemical industry. These applications should be supported with special tests with the media if required.

Trunnion supports CRLNZG

Material:

High-alloy steel

Free of copper, PTFE and silicone

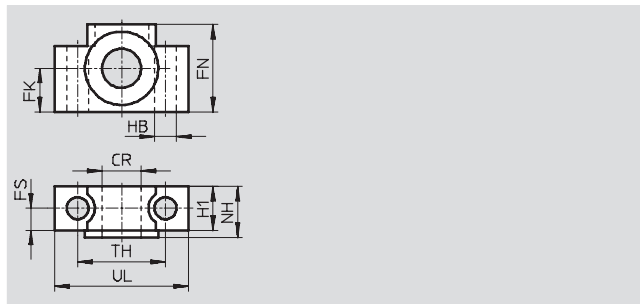
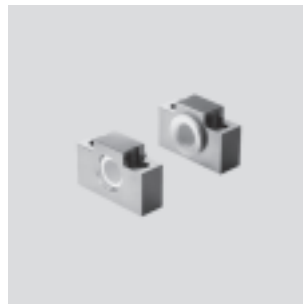

Dimensions and ordering data													
For \varnothing	CR	FK	FN	FS	H1	HB	NH	TH	UL	CRC ¹⁾	Weight	Part No.	Type
[mm]	\varnothing D11	\varnothing ± 0.1				\varnothing H13		± 0.2			[g]		
32	12	15	30	10.5	15	6.6	18	32	46	4	200	161 874	CRLNZG-32
40, 50	16	18	36	12	18	9	21	36	55	4	330	161 875	CRLNZG-40/50
63, 80	20	20	40	13	20	11	23	42	65	4	440	161 876	CRLNZG-63/80
100	25	25	50	16	24.5	14	28.5	50	75	4	740	161 877	CRLNZG-100

1) Corrosion resistance class 4 according to Festo standard 940 070

Components subject to particularly high corrosion stress. Parts used with aggressive media, e.g. in the food or chemical industry. These applications should be supported with special tests with the media if required.

Standard cylinders CDN, ISO 15552, Clean Design

Accessories

Swivel flange SNCB- ... R3

Material:
Die-cast aluminium with protective coating
Free of copper, PTFE and silicone

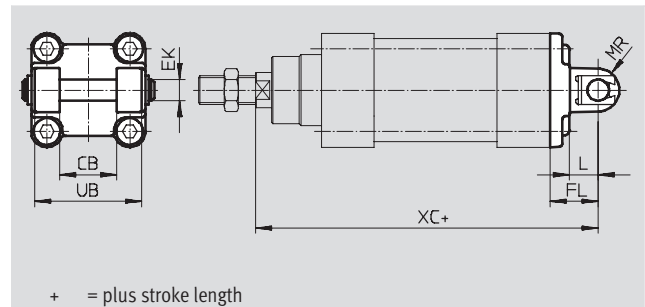

Dimensions and ordering data												
For \varnothing	CB	EK	FL	L	MR	UB	XC	CRC ¹⁾	Weight	Part No.	Type	
[mm]	H14	\varnothing e8	± 0.2			h14			[g]			
32	26	10	22	13	8.5	45	142.7	3	100	176 944	SNCB-32-R3	
40	28	12	25	16	12	52	160.6	3	150	176 945	SNCB-40-R3	
50	32	12	27	16	12	60	171	3	225	176 946	SNCB-50-R3	
63	40	16	32	21	16	70	191.5	3	365	176 947	SNCB-63-R3	
80	50	16	36	22	16	90	210.5	3	610	176 948	SNCB-80-R3	
100	60	20	41	27	20	110	229.6	3	925	176 949	SNCB-100-R3	

1) Corrosion resistance class 3 according to Festo standard 940 070
Components subject to high corrosion stress. External visible parts in direct contact with industrial atmospheres or media such as solvents and cleaning agents, with a predominantly functional requirement for the surface.

Clevis foot CRLNG

Material:
High-alloy steel
Free of copper, PTFE and silicone

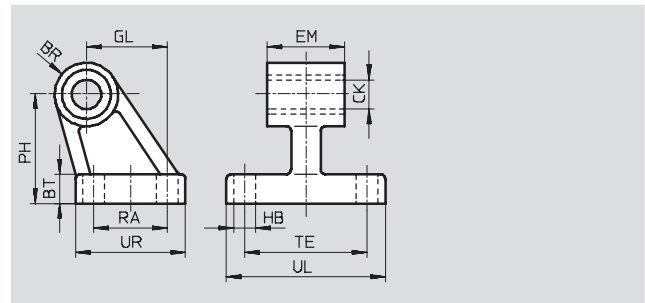

Dimensions and ordering data															
For \varnothing	BR	BT	CK	EM	GL	HB	PH	RA	TE	UL	UR	CRC ¹⁾	Weight	Part No.	Type
[mm]			\varnothing D11	-0.4		\varnothing H13							[g]		
32	10	8	10	25.8	21	6.6	32	18	38	51	31	4	120	161 840	CRLNG-32
40	11	10	12	27.8	24	6.6	36	22	41	54	35	4	160	161 841	CRLNG-40
50	12	12	12	31.8	33	9	45	30	50	65	45	4	280	161 842	CRLNG-50
63	15	12	16	39.8	37	9	50	35	52	67	50	4	375	161 843	CRLNG-63
80	15	14	16	49.8	47	11	63	40	66	86	60	4	580	161 844	CRLNG-80
100	19	15	20	59.8	55	11	71	50	76	96	70	4	935	161 845	CRLNG-100

1) Corrosion resistance class 4 according to Festo standard 940 070
Components subject to particularly high corrosion stress. Parts used with aggressive media, e.g. in the food or chemical industry. These applications should be supported with special tests with the media if required.

Standard cylinders CDN, ISO 15552, Clean Design

FESTO

Accessories

Proximity sensor SMT-C1

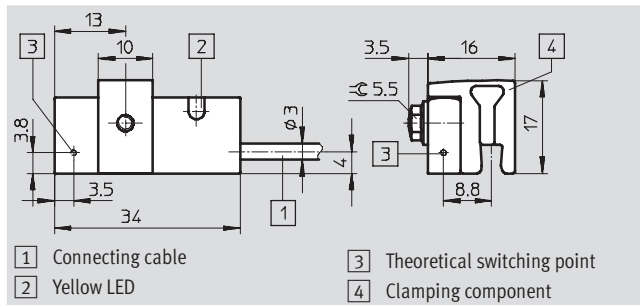
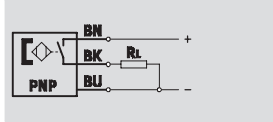

Technical data		
General information		
Design	Block-shaped	
Based on standard	DIN EN 60947-5-2	
Certification	C-Tick	
CE mark (see declaration of conformity)	To EU EMC Directive	
Note on materials	Free of copper, PTFE and halogen	
Input signal/measuring element		
Measuring principle	Magneto-inductive	
Method of measurement	Absolute	
Ambient temperature	[°C]	-20 ... +70
Switching output		
Switching output	PNP	
Switching element function	N/O contact	
Hysteresis	[mm]	≤ 2.0
Switch-on time	[ms]	≤ 0.5
Switch-off time	[ms]	≤ 0.5
Max. output current	[mA]	200
Max. switching capacity DC	[W]	6
Voltage drop	[V]	< 1.8
Inductive protective circuit	Adapted to MZ, MY, ME coils	
Residual current	[mA]	< 0.1
Output, further data		
Protection against short circuit	Pulsed	
Protection against overloading	Yes	
Electronic components		
Operating voltage range	[V DC]	10 ... 30
Residual ripple	[%]	10
Protection against polarity reversal	For all electrical connections	
Electromechanical components		
Electrical connection	Cable, 3-wire	
Connection direction	In-line	
Cable length	[m]	2.5 5.0
Cable sheath colour	Grey	
Cable type	Lif12Y33Y	
Information on cable sheath materials	Thermoplastic polyolefin elastomer	
Wire ends	Wire end sleeve	

Standard cylinders CDN, ISO 15552, Clean Design

Accessories

Technical data	
Mechanical components	
Type of mounting	Clamped
Tightening torque [Nm]	1.2
Mounting position	Any
Product weight [g]	60
Housing colour	Black
Information on housing materials	Polypropylene, high-alloy stainless steel, wrought aluminium alloy, thermoplastic polyurethane elastomer
Display/operation	
Switching status display	Yellow LED
Immissions/emissions	
Ambient temperature with flexible cable installation [°C]	-20 ... +70
Degree of protection	IP65, IP67 to IEC 60529
Corrosion resistance class CRC ¹⁾	3

1) Corrosion resistance class 3 according to Festo standard 940 070
 Components subject to high corrosion stress. External visible parts in direct contact with industrial atmospheres or media such as solvents and cleaning agents, with a predominantly functional requirement for the surface.

Ordering data		
Cable length [m]	Part No.	Type
2.5	540 431	SMT-C1-PS-24V-2,5-OE
5.0	540 432	SMT-C1-PS-24V-5,0-OE

Standard cylinders CDN, ISO 15552, Clean Design

Accessories

Plug socket with cable SIM-K-GD- ... -CDN

Material: Polyurethane, suitable for foodstuffs, resistant to cleaning and disinfecting agents to DIN 11483

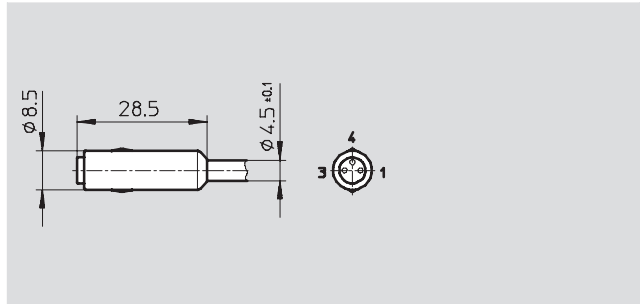

Plug socket with cable SIM-K-WD- ... -CDN

Material: Polyurethane, suitable for foodstuffs, resistant to cleaning and disinfecting agents to DIN 11483

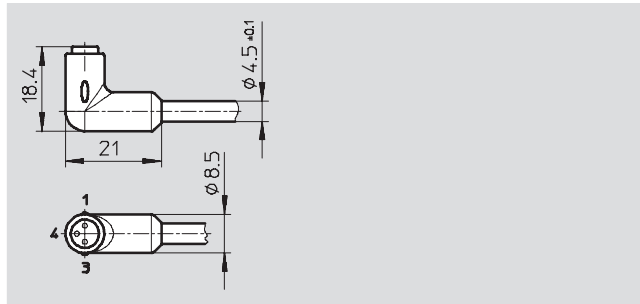
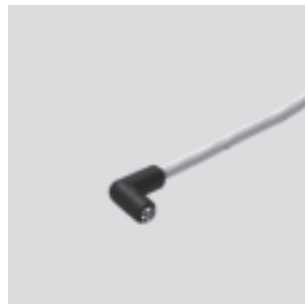

Technical data			SIM-K-...-2,5-CDN	SIM-K-...-5-CDN
Electrical connection			Clip-on plug socket, straight or angled, 3-pin	
Operating voltage range	AC	[V]	≤45	
	DC	[V]	≤70	
Acceptable current load		[A]	2.8	
Cable length		[m]	2.5	5
Cable composition		[mm ²]	3x 0.25	
Wire ends	Tin-plated			
Degree of protection	IP65/IP67/IP69			

Operating and environmental conditions			Fixed	Flexible
Cable installation				
Ambient temperature		[°C]	-30 ... +70	-5 ... +70

Ordering data				
Cable length [m]	Part No.	Type	Part No.	Type
		In-line		Lateral
2.5	525 259	SIM-K-GD-2,5-CDN	525 261	SIM-K-WD-2,5-CDN
5	525 260	SIM-K-GD-5-CDN	525 262	SIM-K-WD-5-CDN

Standard cylinders CDN, ISO 15552, Clean Design

Accessories

FESTO

Bellows kit DADB



General technical data								
Type DADB-V6-		32	40	50	63	80	100	
Max. stroke range of cylinder ¹⁾	[mm]	10 ... 500	10 ... 500	10 ... 500	10 ... 500	10 ... 500	10 ... 500	
Type of mounting		Via threaded pin						
Mounting position		Any						
Resistance to media		Dust, chippings, oil, grease, fuel (→ Internet: Resistance to media)						
Ambient temperature ²⁾	[°C]	-10 ... +80						
Degree of protection		IP54						
Corrosion resistance class CRC ³⁾		3						

1) In conjunction with the bellows kit DADB

2) Note operating range of proximity sensors and cylinder

3) Corrosion resistance class 3 according to Festo standard 940 070

Components subject to high corrosion stress. External visible parts in direct contact with industrial atmospheres or media such as solvents and cleaning agents, with a predominantly functional requirement for the surface.

Materials

Sectional view

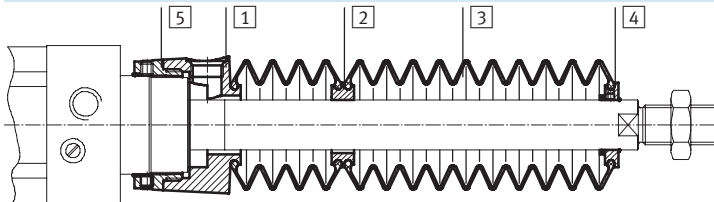

Bellows		
1	Connection	Polyamide
2	Adapter	Polyamide
3	Bellows	Nitrile rubber
4	End piece	Polyamide
5	Connector	Polyamide
-	O-ring	Nitrile rubber
Note on materials		Free of copper and PTFE
		RoHS-compliant

Weight [g]							
Type DADB-V6- Stroke [mm]		32	40	50	63	80	100
10 ... 50		29	42	71	69	99	124
51 ... 125		41	56	91	89	127	152
126 ... 175		52	68	105	103	140	165
176 ... 250		66	85	129	127	193	218
251 ... 300		79	100	147	145	231	255
301 ... 350		92	115	166	164	268	293
351 ... 375		92	115	167	165	159	284
376 ... 425		104	129	185	183	296	321
426 ... 475		117	144	204	202	334	359
476 ... 500		117	144	205	203	324	349

Standard cylinders CDN, ISO 15552, Clean Design

Accessories

FESTO

Speed of travel v as a function of tubing length l

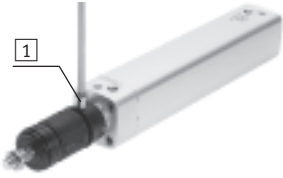

The bellows kit is a leak-free system. To prevent unwanted media from being drawn in, the supply and exhaust air must be ducted via a venting

hole in the connection part **1**. The pressure generated in the bellows kit by the positioning motion is primarily defined by the speed of travel

and the tubing length. The recommended tubing length based on the travel speed of the drive can be read from the graph.

Advancing

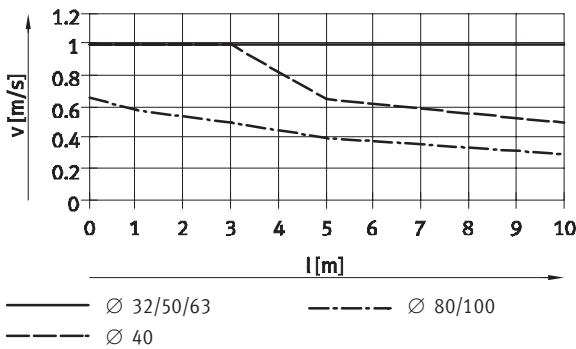

Retracting

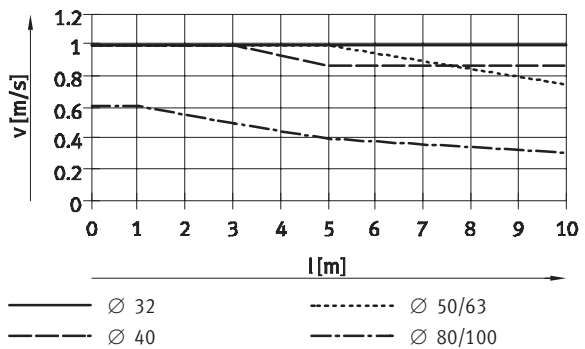

Note
The push-in fittings opposite must be used for the venting hole. Silencers can be used as an alternative. This reduces the travel speed slightly.

Tubing length and push-in fitting for venting hole			
Ø [mm]	Tubing O.D. [mm]	Push-in fitting	
		Part No.	Type
32, 40	8	186 109	QS-G $\frac{1}{8}$ -8-I
		533 929	QS-F-G $\frac{1}{8}$ -8-I
		533 880	QS-F-G $\frac{1}{8}$ -8H
50, 63, 80, 100	12	186 350	QS-G $\frac{1}{4}$ -12
		533 848	QS-F-G $\frac{1}{4}$ -12
		533 884	QS-F-G $\frac{1}{4}$ -12H

Standard cylinders CDN, ISO 15552, Clean Design

Accessories

FESTO

Dimensions

Download CAD data → www.festo.com

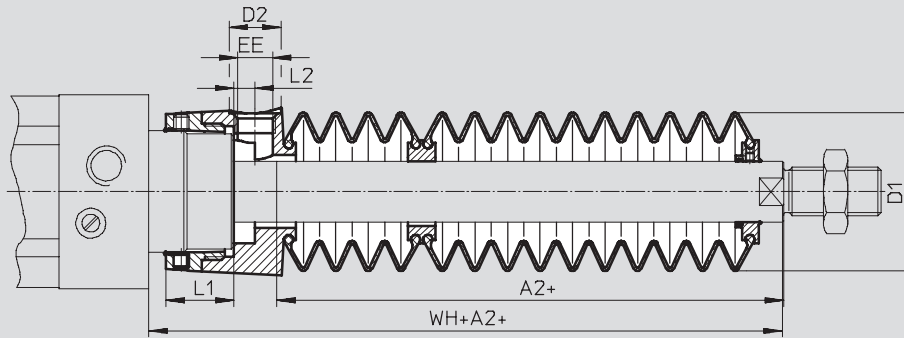

+ = plus stroke length

Stroke [mm]	32							40						
	A2 ¹⁾	D1 max.	D2	EE	L1	L2	WH+A2	A2 ¹⁾	D1 max.	D2	EE	L1	L2	WH+A2
10 ... 50	29	38	14	G ¹ / ₈	12.9	5.4	55	28	46	14	G ¹ / ₈	16.3	5.4	58
51 ... 125	47						73	43						73
126 ... 175	61						87	56						86
176 ... 250	80						106	72						102
251 ... 300	96						122	86						116
301 ... 350	112						138	100						130
351 ... 375	114						140	101						131
376 ... 425	130						156	115						145
426 ... 475	145						171	130						160
476 ... 500	147						173	131						161

Stroke [mm]	50							63						
	A2 ¹⁾	D1 max.	D2	EE	L1	L2	WH+A2	A2 ¹⁾	D1 max.	D2	EE	L1	L2	WH+A2
10 ... 50	28	57	17	G ¹ / ₄	22.35	7	65	28	57	17	G ¹ / ₄	22.4	7	65
51 ... 125	46						83	46						83
126 ... 175	56						93	56						93
176 ... 250	73						110	73						110
251 ... 300	86						123	86						123
301 ... 350	97						134	97						134
351 ... 375	105						142	105						142
376 ... 425	116						153	116						153
426 ... 475	126						163	126						163
476 ... 500	134						171	134						171

Stroke [mm]	80							100						
	A2 ¹⁾	D1 max.	D2	EE	L1	L2	WH+A2	A2 ¹⁾	D1 max.	D2	EE	L1	L2	WH+A2
10 ... 50	25	93	17	G ¹ / ₄	28	4	71	25	93	17	G ¹ / ₄	28	4	71
51 ... 125	37						83	37						83
126 ... 175	49						95	49						95
176 ... 250	62						108	62						108
251 ... 300	74						120	74						120
301 ... 350	86						132	86						132
351 ... 375	87						133	87						133
376 ... 425	98						144	98						144
426 ... 475	110						156	110						156
476 ... 500	111						157	111						157

1) The dimension corresponds to the K8 value (extended piston rod) of the drive

Standard cylinders CDN, ISO 15552, Clean Design

Accessories

Ordering data – Bellows kit

An extended piston rod (order code K8) → 16 is absolutely necessary for using a bellows kit.

The necessary dimension for K8 as a function of piston diameter and cylinder stroke as well as the corresponding bellows kit is indicated in the table below:

Order example:

Selected standard cylinder:

CDN-32-320-PPV-AIB-SME-...

The dimension for the corresponding K8 value (see table):
112 mm

Complete type code for standard cylinder:

CDN-32-320-PPV-AIB-SME-...-112K8

The corresponding bellows kit:



DADB-V6-32-S301-350

Cylinder data			Bellows kit		Cylinder data			Bellows kit	
∅	Stroke	Dimension for K8	Part No.	Type	∅	Stroke	Dimension for K8	Part No.	Type
[mm]	[mm]	[mm]			[mm]	[mm]	[mm]		
32	10 ... 50	29	553 271	DADB-V6-32-S10-50	40	10 ... 50	28	553 291	DADB-V6-40-S10-50
	51 ... 125	47	553 273	DADB-V6-32-S51-125		51 ... 125	43	553 293	DADB-V6-40-S51-125
	126 ... 175	61	553 275	DADB-V6-32-S126-175		126 ... 175	56	553 295	DADB-V6-40-S126-175
	176 ... 250	80	553 277	DADB-V6-32-S176-250		176 ... 250	72	553 297	DADB-V6-40-S176-250
	251 ... 300	96	553 279	DADB-V6-32-S251-300		251 ... 300	86	553 399	DADB-V6-40-S251-300
	301 ... 350	112	553 281	DADB-V6-32-S301-350		301 ... 350	100	553 301	DADB-V6-40-S301-350
	351 ... 375	114	553 283	DADB-V6-32-S351-375		351 ... 375	101	553 303	DADB-V6-40-S351-375
	376 ... 425	130	553 285	DADB-V6-32-S376-425		376 ... 425	115	553 305	DADB-V6-40-S376-425
	426 ... 475	145	553 287	DADB-V6-32-S426-475		426 ... 475	130	553 307	DADB-V6-40-S426-475
	476 ... 500	147	553 289	DADB-V6-32-S476-500		476 ... 500	131	553 309	DADB-V6-40-S476-500
50	10 ... 50	28	553 311	DADB-V6-50-S10-50	63	10 ... 50	28	553 331	DADB-V6-63-S10-50
	51 ... 125	46	553 313	DADB-V6-50-S51-125		51 ... 125	46	553 333	DADB-V6-63-S51-125
	126 ... 175	56	553 315	DADB-V6-50-S126-175		126 ... 175	56	553 335	DADB-V6-63-S126-175
	176 ... 250	73	553 317	DADB-V6-50-S176-250		176 ... 250	73	553 337	DADB-V6-63-S176-250
	251 ... 300	86	553 319	DADB-V6-50-S251-300		251 ... 300	86	553 339	DADB-V6-63-S251-300
	301 ... 350	97	553 321	DADB-V6-50-S301-350		301 ... 350	97	553 341	DADB-V6-63-S301-350
	351 ... 375	105	553 323	DADB-V6-50-S351-375		351 ... 375	105	553 343	DADB-V6-63-S351-375
	376 ... 425	116	553 325	DADB-V6-50-S376-425		376 ... 425	116	553 345	DADB-V6-63-S376-425
	426 ... 475	126	553 327	DADB-V6-50-S426-475		426 ... 475	126	553 347	DADB-V6-63-S426-475
	476 ... 500	134	553 329	DADB-V6-50-S476-500		476 ... 500	134	553 349	DADB-V6-63-S476-500
80	10 ... 50	25	553 351	DADB-V6-80-S10-50	100	10 ... 50	25	553 371	DADB-V6-100-S10-50
	51 ... 125	37	553 353	DADB-V6-80-S51-125		51 ... 125	37	553 373	DADB-V6-100-S51-125
	126 ... 175	49	553 355	DADB-V6-80-S126-175		126 ... 175	49	553 375	DADB-V6-100-S126-175
	176 ... 250	62	553 357	DADB-V6-80-S176-250		176 ... 250	62	553 377	DADB-V6-100-S176-250
	251 ... 300	74	553 359	DADB-V6-80-S251-300		251 ... 300	74	553 379	DADB-V6-100-S251-300
	301 ... 350	86	553 361	DADB-V6-80-S301-350		301 ... 350	86	553 381	DADB-V6-100-S301-350
	351 ... 375	87	553 363	DADB-V6-80-S351-375		351 ... 375	87	553 383	DADB-V6-100-S351-375
	376 ... 425	98	553 365	DADB-V6-80-S376-425		376 ... 425	98	553 385	DADB-V6-100-S376-425
	426 ... 475	110	553 367	DADB-V6-80-S426-475		426 ... 475	110	553 387	DADB-V6-100-S426-475
	476 ... 500	111	553 369	DADB-V6-80-S476-500		476 ... 500	111	553 389	DADB-V6-100-S476-500

Standard cylinders CDN, ISO 15552, Clean Design

FESTO

Accessories

Ordering data – Push-in fittings				Technical data → Internet: quick star			
	Connection		Material	Weight [g]	Part No.	Type	PU ³⁾
	Thread	Tubing O.D.					
With external hex							
	G ¹ / ₈	4	Brass, nickel-plated and chrome-plated	8	193 408	QS-F-G ¹ / ₈ -4 ¹⁾	10
		6		12	193 409	QS-F-G ¹ / ₈ -6 ¹⁾	10
		8		14	193 410	QS-F-G ¹ / ₈ -8 ¹⁾	10
	G ¹ / ₄	6		16	193 411	QS-F-G ¹ / ₄ -6 ¹⁾	10
		8		16	193 412	QS-F-G ¹ / ₄ -8 ¹⁾	10
		10		22	193 413	QS-F-G ¹ / ₄ -10 ¹⁾	10
	G ³ / ₈	8		20	193 414	QS-F-G ³ / ₈ -8 ¹⁾	10
		10		30	193 415	QS-F-G ³ / ₈ -10 ¹⁾	10
		12		38	193 487	QS-F-G ³ / ₈ -12 ¹⁾	10
	G ¹ / ₂	10		42	193 416	QS-F-G ¹ / ₂ -10 ¹⁾	10
		12		46	193 417	QS-F-G ¹ / ₂ -12 ¹⁾	10
	With external hex						
	R ¹ / ₈	6	Stainless steel	9.9	162 862	CRQS- ¹ / ₈ -6 ²⁾	1
		8		13	162 863	CRQS- ¹ / ₈ -8 ²⁾	1
	R ¹ / ₄	8		18	162 864	CRQS- ¹ / ₄ -8 ²⁾	1
		10		22	162 865	CRQS- ¹ / ₄ -10 ²⁾	1
	R ³ / ₈	10		29	162 866	CRQS- ³ / ₈ -10 ²⁾	1
		12		38	162 867	CRQS- ³ / ₈ -12 ²⁾	1
	R ¹ / ₂	12		55	162 868	CRQS- ¹ / ₂ -12 ²⁾	1
		16		59	162 869	CRQS- ¹ / ₂ -16 ²⁾	1
	With internal hex						
	G ¹ / ₈	4	Brass, nickel-plated and chrome-plated	8.6	533 927	QS-F-G ¹ / ₈ -4-I ¹⁾	10
		6		13.4	533 928	QS-F-G ¹ / ₈ -6-I ¹⁾	10
		8		13.1	533 929	QS-F-G ¹ / ₈ -8-I ¹⁾	10
	G ¹ / ₄	8		14.6	533 930	QS-F-G ¹ / ₄ -8-I ¹⁾	10
		10		21	533 931	QS-F-G ¹ / ₄ -10-I ¹⁾	10
	G ³ / ₈	12		34.3	533 932	QS-F-G ³ / ₈ -12-I ¹⁾	10

- 1) With sealing ring
- 2) With PTFE coating
- 3) Packaging unit quantity

Ordering data – Push-in L-fittings				Technical data → Internet: quick star			
	Connection		Material	Weight [g]	Part No.	Type	PU ³⁾
	Thread	Tubing O.D.					
With external hex							
	G ¹ / ₈	4	Brass, nickel-plated and chrome-plated	17.6	193 418	QSL-F-G ¹ / ₈ -4 ¹⁾	10
		6		16	193 419	QSL-F-G ¹ / ₈ -6 ¹⁾	10
		8		20	193 420	QSL-F-G ¹ / ₈ -8 ¹⁾	10
	G ¹ / ₄	6		24.5	193 421	QSL-F-G ¹ / ₄ -6 ¹⁾	10
		8		24	193 422	QSL-F-G ¹ / ₄ -8 ¹⁾	10
		10		34.6	193 423	QSL-F-G ¹ / ₄ -10 ¹⁾	10
	G ³ / ₈	12		49	533 853	QSL-F-G ¹ / ₄ -12 ¹⁾	10
		8		34.2	193 424	QSL-F-G ³ / ₈ -8 ¹⁾	10
		10		36.6	193 425	QSL-F-G ³ / ₈ -10 ¹⁾	10
	G ¹ / ₂	12		51.1	197 486	QSL-F-G ³ / ₈ -12 ¹⁾	10
		10		66	193 426	QSL-F-G ¹ / ₂ -10 ¹⁾	10
		12		70	193 427	QSL-F-G ¹ / ₂ -12 ¹⁾	10

- 1) With sealing ring
- 3) Packaging unit quantity

Standard cylinders CDN, ISO 15552, Clean Design

Accessories

Ordering data – Push-in L-fittings				Technical data → Internet: crqsl			
	Connection		Material	Weight [g]	Part No.	Type	PU ³⁾
	Thread	Tubing O.D.					
With external hex							
	R1/8	6	Stainless steel	20	162 872	CRQSL-1/8-6 ²⁾	1
		8		27	162 873	CRQSL-1/8-8 ²⁾	1
	R1/4	8		31	162 874	CRQSL-1/4-8 ²⁾	1
		10		46	162 875	CRQSL-1/4-10 ²⁾	1
	R3/8	10		52	162 876	CRQSL-3/8-10 ²⁾	1
		12		69	162 877	CRQSL-3/8-12 ²⁾	1
	R1/2	12		89	162 878	CRQSL-1/2-12 ²⁾	1
		16		105	162 879	CRQSL-1/2-16 ²⁾	1



- 2) With PTFE coating
- 3) Packaging unit quantity

Ordering data – Plastic tubing, standard O.D.		Technical data → Internet: tubing
		Type
	Good resistance to chemicals and hydrolysis	PLN
	Pneumatic tubing with resistance to high temperatures and chemicals	PFAN
	Approved for use in the food industry and hydrolysis-resistant	PUN-H

Ordering data – One-way flow control valves				Technical data → Internet: crgla			
	Connection		Material	Weight [g]	Part No.	Type	
	Thread	For push-in fitting					
	G1/8	CRQS/CRQSL/CRQST,	Electrolytically polished special steel casting	44	161 404	CRGRLA-1/8-B	
	G1/4	Quick Star		83	161 405	CRGRLA-1/4-B	
	G3/8			150	161 406	CRGRLA-3/8-B	
	G1/2			315	161 407	CRGRLA-1/2-B	

Ordering data – Blanking screws, corrosion-resistant						
	For Ø	Material	CRC ¹⁾	Weight [g]	Part No. Type	PU ³⁾
	32, 40	High-alloy steel	3	3	650 120 CR-M6x12-DIN6921-A2-70	4
	50, 63		3	6	650 121 CR-M8x16-DIN6921-A2-70	4
	80, 100		3	13	650 122 CR-M10x16-DIN6921-A2-70	4

- 1) Corrosion resistance class 3 according to Festo standard 940 070
Components subject to high corrosion stress. External visible parts in direct contact with industrial atmospheres or media such as solvents and cleaning agents, with a predominantly functional requirement for the surface.

Ordering data – Corrosion and acid-resistant piston rod attachments						Technical data → Internet: crsg			
	For Ø	Part No.	Type						
					For Ø	Part No.	Type		
Rod eye CRSGS				Rod clevis CRSG					
	32	195 582	CRSGS-M10x1,25		32	13 569	CRSG-M10x1,25		
	40	195 583	CRSGS-M12x1,25		40	13 570	CRSG-M12x1,25		
	50, 63	195 584	CRSGS-M16x1,5		50, 63	13 571	CRSG-M16x1,5		
	80, 100	195 585	CRSGS-M20x1,5		80, 100	13 572	CRSG-M20x1,5		