



- Permits easy adjustment
- Wide choice of mounting options

Adjusting units HMXY

Key features



Key features at a glance

Mounting options

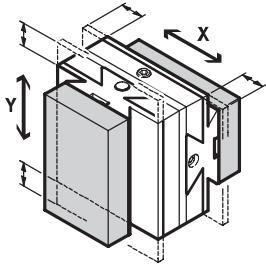

- Precision adjusting unit in X and Y directions
- Allows easy adjustment of grippers to obtain precise gripping position
- Versatile precision interfaces using centring sleeves
- Wide choice of mounting options:
 - Direct mounting
 - Dovetail mounting

Combination with drives and grippers

Mounting on the basic components → 5 / 3.4-25

Linear modules
HMP/HMPL



Mini slides
DGSL



Mini slides
SLT



Adapter kits

- Direct mounting
- Dovetail mounting



Adjusting unit HMXY

- Interface between basic component and attachment component



Angle adapter
HMSVS



Angle adapter
HMSVS



Angle adapter HMSVS

→ 5 / 3.4-2

Adapter kits

- Direct mounting
- Dovetail mounting



Mounting the attachment component → 5 / 3.4-30



Mini slides
DGSL



Mini slides
SLT



Semi-rotary drives
DRQD



Grippers
HGD, HGP, HGR, HGW
HGPP, HGPPi
Parallel grippers, micro
HGPM, HGWM

Adjusting units HMX

Technical data

Adjusting unit



General technical data		HMX-1	HMX-2
Adjustment travel	y [mm]	7.5	7.5
	z [mm]	7.5	7.5
Max. static characteristic load values → Fig. 1	Forces		
	F_x [N]	50	160
	F_y [N]	50	160
	Torques		
	M_x [Nm]	1.4	20
Mass moment of inertia → Fig. 2	M_y [Nm]	1.4	20
	M_z [Nm]	1.4	20
	J_x [kgm ² x10 ⁻⁴]	0.499	8.650
	J_y [kgm ² x10 ⁻⁴]	0.361	5.121
	J_z [kgm ² x10 ⁻⁴]	0.361	5.121
Weights	[g]	155	2,324
Ambient temperature	[°C]	5 ... 60	
Corrosion resistance class CRC ¹⁾		2	
Materials		Anodised aluminium	
Note on materials		Free of copper, PTFE and silicone	

1) Corrosion resistance class 2 to Festo standard 940 070

Components subject to moderate corrosion stress. Externally visible parts with primarily decorative surface requirements which are in direct contact with a normal industrial environment or media such as coolants or lubricating agents.

Max. permissible static characteristic load values
Fig. 1

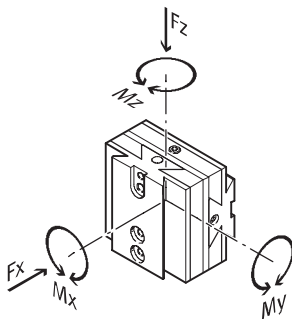

Mass moments of inertia
Fig. 2

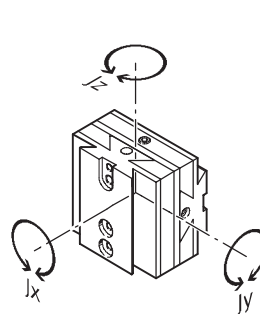

Adjusting units HMX

Technical data



Dimensions

Download CAD data → www.festo.com/en/engineering

HMX-1

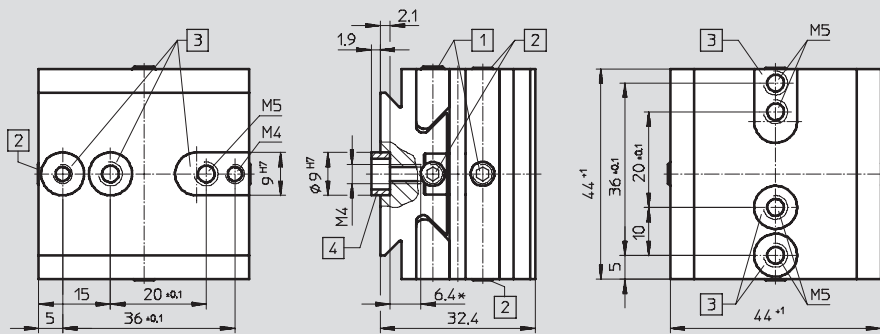

- 1 Locking screw
- 2 Adjusting screw
- 3 Centring hole/slot
- 4 For centring sleeve ZBH-9
(2 pieces included in scope of delivery)

* For M4 and M5 threads

HMX-3

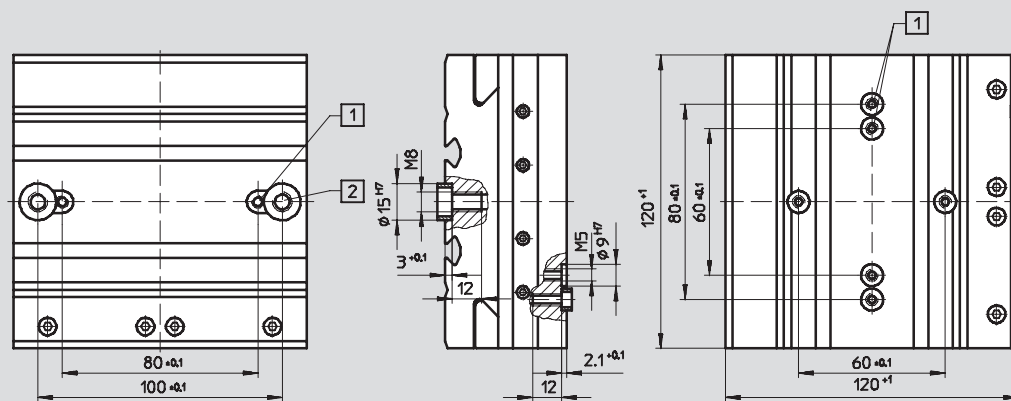

- 1 For centring sleeve ZBH-9
(2 pieces included in scope of delivery)
- 2 For centring sleeve ZBH-15
(2 pieces included in scope of delivery)

Ordering data

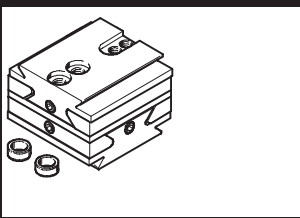

Part No.	Type
187 582	HMX-1
526 030	HMX-3

Adjusting units HMXY

Technical data – Mounting on the basic component

Mounting on linear module HMP/HMPL

Material:

Adapter kit HMSV: Wrought aluminium alloy

Free of copper, PTFE and silicone

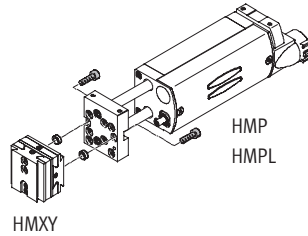

Direct mounting

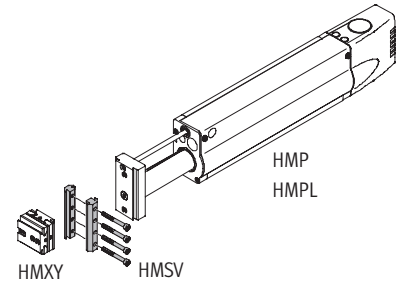

Dovetail mounting

Dimensions and ordering data

Download CAD data → www.festo.com/en/engineering

Direct mounting

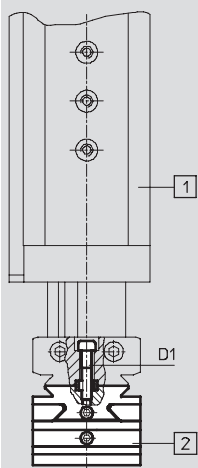

- 1 Linear module HMP/HMPL
- 2 Adjusting unit HMXY

Basic component	Adjusting unit	Screws ¹⁾ D1
HMP-16/20	HMXY-3	2x M5x25
HMP-25/32		2x M5x30
HMPL-12/16/20	HMXY-1	2x M5x16

1) The screws listed are not included with the adjusting unit.

Adjusting units HMX

Technical data – Mounting on the basic component

Mounting on linear module HMP/HMPL

Dimensions and ordering data

Download CAD data → www.festo.com/en/engineering

Dovetail mounting

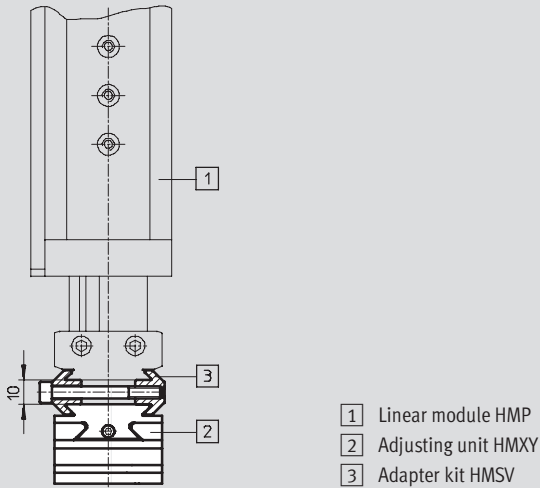

Basic component	Adjusting unit	Part No.	Type
HMP-16/20/25/32	HMX-1	177 647	HMSV-1
HMP-16/20/25/32	HMX-3	177 649	HMSV-3

Adjusting units HMXY

Technical data – Mounting on the basic component

Mounting on mini slide SLT

Material:

Adapter kit HAPG: Wrought aluminium alloy

Free of copper, PTFE and silicone

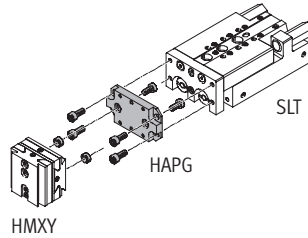

Direct mounting

Dimensions and ordering data

Download CAD data → www.festo.com/en/engineering

Direct mounting

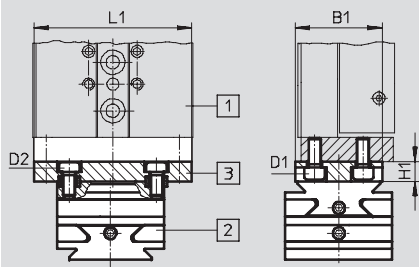

- 1 Mini slide SLT
- 2 Adjusting unit HMXY
- 3 Adapter kit HAPG

Basic component	Adjusting unit	B1	H1	L1	Screws D1	Screws D2	Part No.	Type
SLT-16	HMXY-1	36	8	65	M5x10	M5x12	191 266	HAPG-48
SLT-20		44	10	80	M5x12	M5x14	191 268	HAPG-50
SLT-25	HMXY-1/3	44	12	91	M6x16	M5x14	191 270	HAPG-52

Adjusting units HMXY

Technical data – Mounting on the basic component



Mounting on angle adapter HMSVS

Material:

Adapter kit HMSV: Wrought aluminium alloy

Free of copper, PTFE and silicone

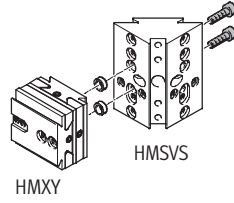

HMXY

HMSVS

Direct mounting

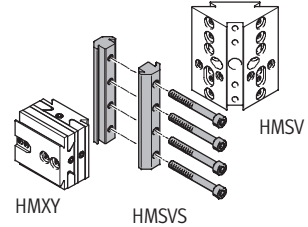

HMXY

HMSVS

HMSV

Dovetail mounting

Dimensions and ordering data

Download CAD data → www.festo.com/en/engineering

Direct mounting

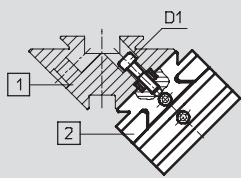

- 1 Angle adapter HMSVS
- 2 Adjusting unit HMXY

Basic component	Adjusting unit	Screws ¹⁾ D1
HMSVS-1	HMXY-1	2x M5x16

1) The screws listed are not included with the adjusting unit.

Dovetail mounting

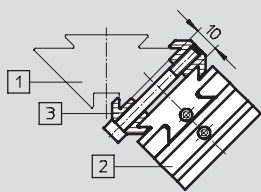

- 1 Angle adapter HMSVS
- 2 Adjusting unit HMXY
- 3 Adapter kit HMSV

Basic component	Adjusting unit	Part No.	Type
HMSVS-1/2/3	HMXY-1	177 647	HMSV-1
	HMXY-3	177 649	HMSV-3

Adjusting units HMXY

Technical data – Mounting the attachment components

Mounting on mini slide DGSL

Material:
 Adapter kit HMSV:
 Wrought aluminium alloy
 Free of copper, PTFE and silicone

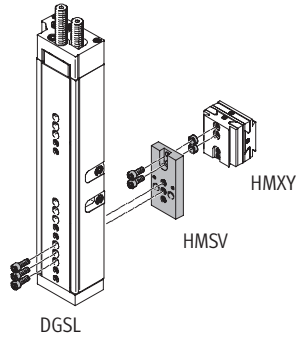

Direct mounting

Dimensions and ordering data

Download CAD data → www.festo.com/en/engineering

Direct mounting

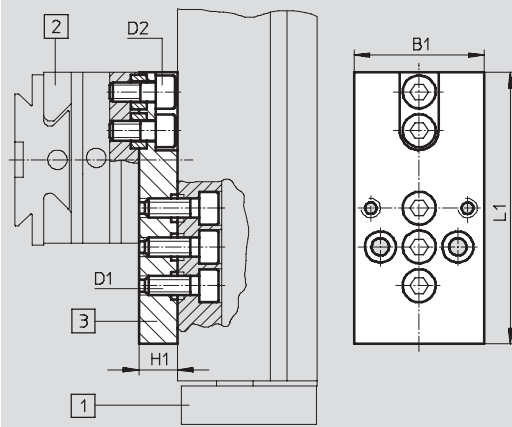

- 1 Mini slide DGSL
- 2 Adjusting unit HMXY
- 3 Adapter kit HMSV

Attachment component	Adjusting unit	B1	D1	D2	H1	L1	Part No.	Type
DGSL-4/6	HMXY-1	33.6	M3	M5	10	70	548 787	HMSV-57
DGSL-8/10	HMXY-1	33.6	M4	M5	10	70		
DGSL-12/16	HMXY-1	33.6	M5	M5	10	70	548 782	HMSV-52
DGSL-20/25	HMXY-3	40	M6	M5	10	100	548 929	HMSV-60

Adjusting units HMX

Technical data – Mounting the attachment component



Mounting on mini slide SLT

Material:

Adapter kit HMSV: Wrought aluminium alloy

Free of copper, PTFE and silicone

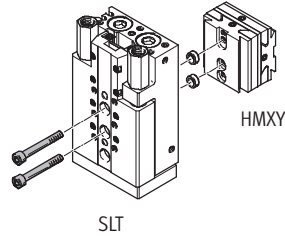

Direct mounting

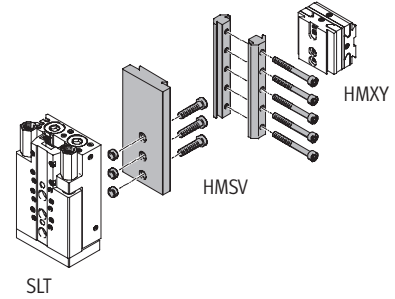

Dovetail mounting

Dimensions and ordering data

Download CAD data → www.festo.com/en/engineering

Direct mounting

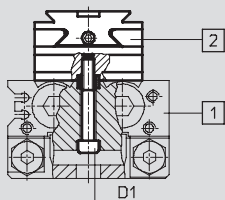

- 1 Mini slide SLT
- 2 Adjusting unit HMX

Attachment component	Adjusting unit	Screws ¹⁾ D1
SLT-16	HMX-1	2x M5x38

1) The screws listed are not included with the adjusting unit.

Dovetail mounting

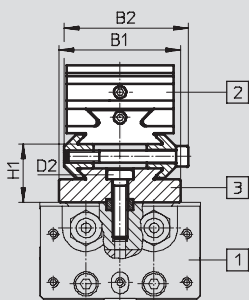

- 1 Mini slide SLT
- 2 Adjusting unit HMX
- 3 Adapter kit HMSV

Attachment component	Adjusting unit	B1	B2	H1	Screws D2	Part No.	Type
SLT-6	HMX-1/3	40	51	22	M3x20	178 329	HMSV-34
SLT-10		40	51	22	M4x30	178 330	HMSV-35
SLT-16		50	51	24	M6x25	178 331	HMSV-36
SLT-20		80	51	26	M6x25	178 332	HMSV-37
SLT-25	HMX-3	80	51	26	M8x25		

Adjusting units HMXY

Technical data – Mounting the attachment component

Mounting on semi-rotary drive DRQD

Material:

Adapter kit HAPG, HMSV:

Wrought aluminium alloy

Free of copper, PTFE and silicone

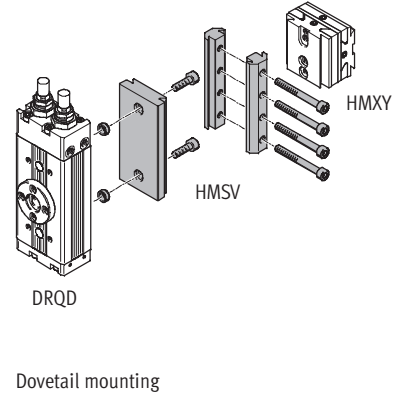
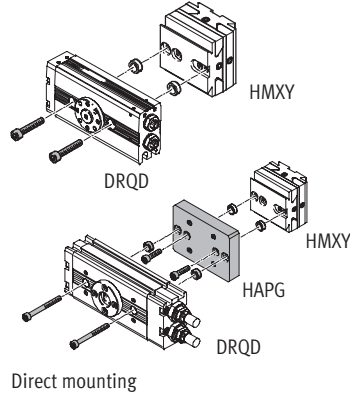

Dimensions and ordering data

Download CAD data → www.festo.com/en/engineering

Direct mounting

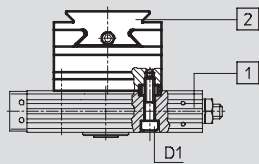

- 1 Semi-rotary drive DRQD
- 2 Adjusting unit HMXY

Attachment component	Adjusting unit	Screws ¹⁾ D1	Part No.	Type
DRQD-6	HMXY-1	–	193 920	HAPG-36-S2
DRQD-8		2x M4x20	–	
DRQD-12		2x M4x25	–	
DRQD-16/20		–	192 707	HAPG-38
DRQD-32	HMXY-3	2x M5x55	–	
DRQD-40		2x M8x75 ²⁾	–	
DRQD-50		2x M8x90 ³⁾	–	

- 1) The screws listed are not included with the adjusting unit.
- 2) The terminal length should be 60 mm.
- 3) The terminal length should be 75 mm.

Dovetail mounting

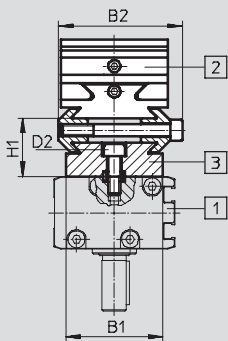

- 1 Semi-rotary drive DRQD
- 2 Adjusting unit HMXY
- 3 Adapter kit HMSV

Attachment component	Adjusting unit	B1	B2	H1	Screws D2	Part No.	Type
DRQD-16/20	HMXY-1/3	40	51	22	M5x16	177 656	HMSV-10
DRQD-25	HMXY-3	50	51	24	M5x10	177 660	HMSV-14
DRQD-32						177 665	HMSV-19

Adjusting units HMXY

Technical data – Mounting the attachment component



Mounting on angle adapter HMSVS

Material:

Adapter kit HMSV:

Wrought aluminium alloy

Free of copper, PTFE and silicone

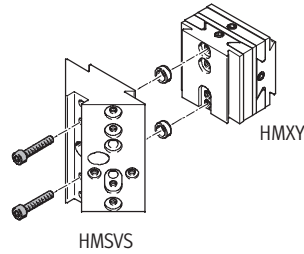

Direct mounting

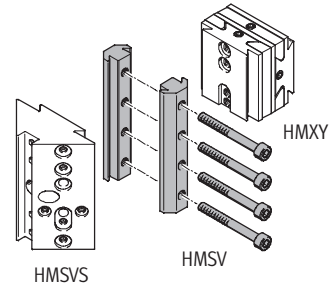

Dovetail mounting

Dimensions and ordering data

Download CAD data → www.festo.com/en/engineering

Direct mounting

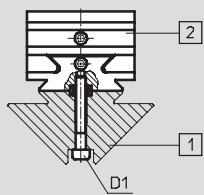

- 1 Angle adapter HMSVS
- 2 Adjusting unit HMXY

Attachment component	Adjusting unit	Screws ¹⁾ D1
HMSVS-1	HMXY-1	2x M4x32
HMSVS-2/3	HMXY-3	2x M5x40

1) The screws listed are not included with the adjusting unit.

Dovetail mounting

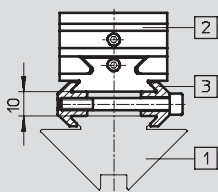

- 1 Angle adapter HMSVS
- 2 Adjusting unit HMXY
- 3 Adapter kit HMSV

Attachment component	Adjusting unit	Part No.	Type
HMSVS-1/2	HMXY-1	177 647	HMSV-1
HMSVS-1/2/3	HMXY-3	177 649	HMSV-3

Adjusting units HMXY

Technical data – Mounting the attachment component



Mounting on gripper HGD/HGP/HGR/HGW

Material:

Adapter kit HAPG:

Wrought aluminium alloy

Free of copper, PTFE and silicone

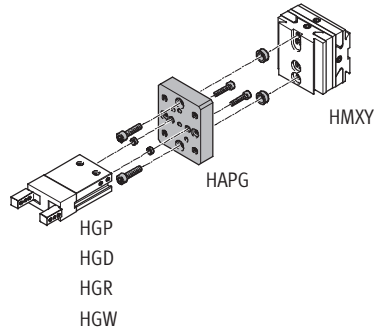

Direct mounting

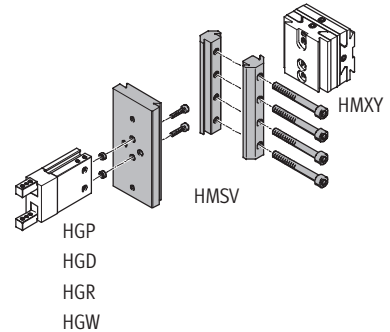

Dovetail mounting

Dimensions and ordering data

Download CAD data → www.festo.com/en/engineering

Direct mounting

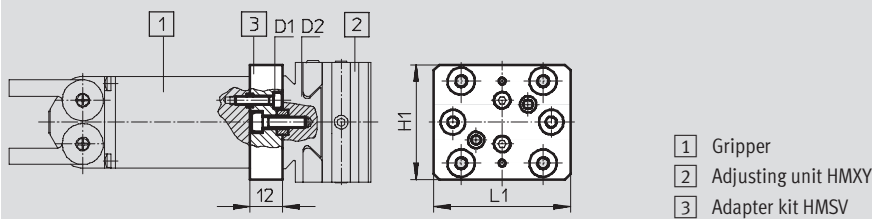

- 1 Gripper
- 2 Adjusting unit HMXY
- 3 Adapter kit HMSV

Attachment component	Adjusting unit	H1	L1	Screws D1	Screws D2	Part No.	Type
HGP-6, HGR-10, HGW-10	HMXY-1	42	50	M3x14	M4x16	192 706	HAPG-37-S1
HGD-16		42	50	M3x20	M4x16	193 921	HAPG-36-S3
HGP-10, HGR-16, HGW-16		42	50	M3x14	M4x16	192 705	HAPG-36-S1
HGP-16, HGR-25, HGW-25		42	50	M4x14	M4x16	193 922	HAPG-37-S4

Adjusting units HMXY

Technical data – Mounting the attachment component

Mounting on gripper HGD/HGP/HGR/HGW

Dimensions and ordering data

Download CAD data → www.festo.com/en/engineering

Dovetail mounting

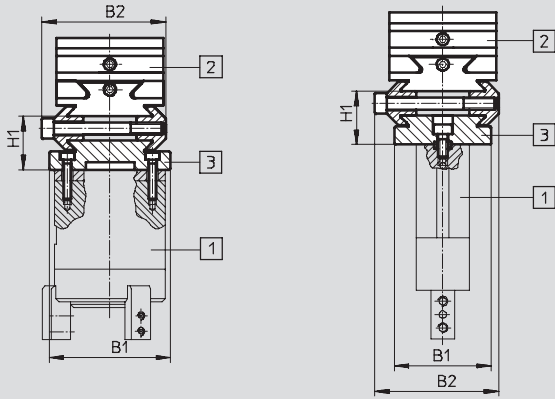

- 1 Gripper
- 2 Adjusting unit HMXY
- 3 Adapter kit HMSV

Attachment component	Adjusting unit	B1	B2	H1	Part No.	Type
HGP-10, HGR-16, HGW-16	HMXY-1/3	40	51	22	177 767	HMSV-27
HGP-16, HGR-25, HGW-25					177 768	HMSV-28
HGP-25, HGR-32, HGW-32	HMXY-1/3	50	51	24	177 769	HMSV-29
HGD-32	HMXY-3	50	51	22	178 212	HMSV-32
HGP-35, HGR-40, HGW-40	HMXY-3	60	51	28	177 770	HMSV-30
HGD-50	HMXY-3	70	51	24	178 213	HMSV-33

Adjusting units HMXY

Technical data – Mounting the attachment component



Mounting on parallel gripper HGPP

Material:

Adapter kit HAVB, HMSV, HAPG:

Wrought aluminium alloy

Free of copper, PTFE and silicone

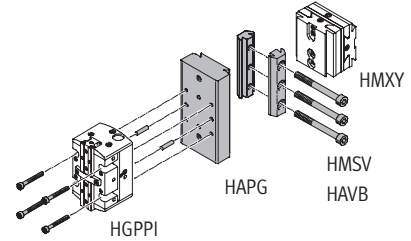

Dovetail mounting

Dimensions and ordering data

Download CAD data → www.festo.com/en/engineering

Dovetail mounting

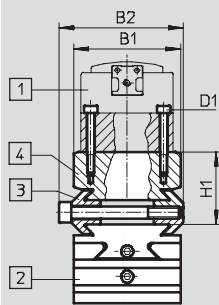

- 1 Parallel gripper HGPP
- 2 Adjusting unit HMXY
- 3 Adapter kit HMSV; HAVB
- 4 Adapter kit HAPG

Attachment component	Adjusting unit	B1	B2	H1	Screws D1	Part No.	Type	Part No.	Type
HGPP-12	HMXY-1	44	51	27.5	M5x30	163 239	HAVB-3	191 262	HAPG-44
	HMXY-3	44	51	30	M5x30	177 649	HMSV-3	191 262	HAPG-44
HGPP-16	HMXY-1	44	51	27.5	M5x30	163 239	HAVB-3	191 263	HAPG-45
	HMXY-3	44	51	30	M5x30	177 649	HMSV-3	191 263	HAPG-45
HGPP-20	HMXY-1	50	51	19.5	M5x30	163 239	HAVB-3	191 265	HAPG-47
	HMXY-3	50	51	22	M5x30	177 649	HMSV-3	191 265	HAPG-47
HGPP-25	HMXY-1	60	51	25.5	M5x40	163 239	HAVB-3	529 019	HAPG-59
	HMXY-3	60	51	28	M5x40	177 649	HMSV-3	529 019	HAPG-59
HGPP-32	HMXY-3	60	51	28	M5x50	177 653	HMSV-7	529 020	HAPG-61

Adjusting units HMX

Technical data – Mounting the attachment component



Mounting on three-point gripper HGDT

Material:

Adapter kit HAPG:

Wrought aluminium alloy

Free of copper, PTFE and silicone

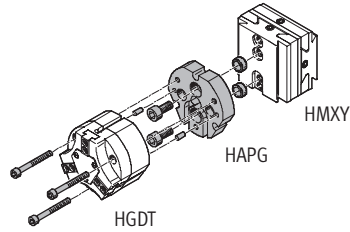

Direct mounting

Dimensions and ordering data

Download CAD data → www.festo.com/en/engineering

Direct mounting

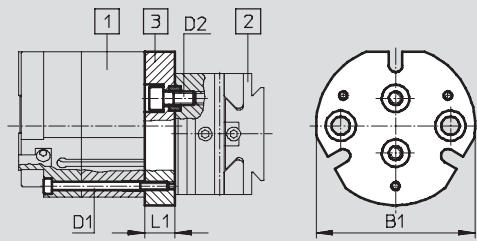

- 1 Three-point gripper HGDT
- 2 Adjusting unit HMX
- 3 Adapter kit HMSV

Attachment component	Adjusting unit	B1	D1	D2	L1	Part No.	Type
HGDT-25	HMX-1	48	M3	M5	10	542 439	HAPG-SD2-32
HGDT-32		58	M3	M5	11	542 436	HAPG-94