

- Simple commissioning
- High torque and compact design
- Optionally with encoder
- Specially matched motor controller combinations

Stepper motors EMMS-ST

Key features

Everything from a single source

Stepper motors EMMS-ST

→ 16



- 2-phase hybrid technology
- Optionally integrated encoder for “Servo Lite operation” (closed loop)
- Sinusoidal current impressing
- Optionally with holding brake
- Protection class: IP54

Gear unit EMGA-SST

→ 23



- Spur toothed planetary gearing
- Gear reduction = 3:1 and 5:1, available ex-stock
- Life lubrication
- Protection class: IP54

Motor controller CMMS-ST

→ 5 / 2.2-75



- Positioning controller with setpoint specifications for positions, rotational speed and torque
- “Servo Lite operation” (closed loop) with encoder option, in other words no step losses, current following errors are corrected
- Interfaces:
 - I/O interface
 - CANopen
 - Profibus DP
 - DeviceNet

Power supply units SVG

→ 82



- Robust hardware
- Input voltage 230 V AC / 115 V AC
- Output voltage 24, 48 V DC
- Output current 5, 10, 20 A

Motor and encoder cables NEBM

→ 24



- Screened cables
- Suitable for chain link trunking
- Protection class IP67

Axial kits EAMM

→ www.festo.com



- Specified kits for all electromechanical axes from Festo

Stepper motors EMMS-ST

Type codes

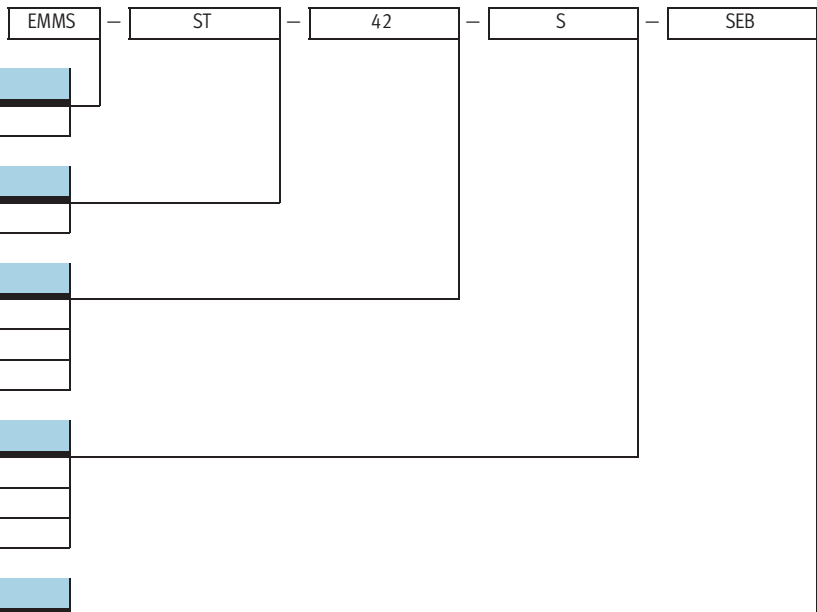

Type

EMMS	Motor
------	-------

Motor type

ST	Stepper motor
----	---------------

Flange dimensions

42	42 mm
57	57 mm
87	87 mm

Gradation of the overall length

S	Small
M	Medium
L	Large

Additional function

S	Straight connection
E	Encoder
B	Brake

Stepper motors EMMS-ST

Technical data

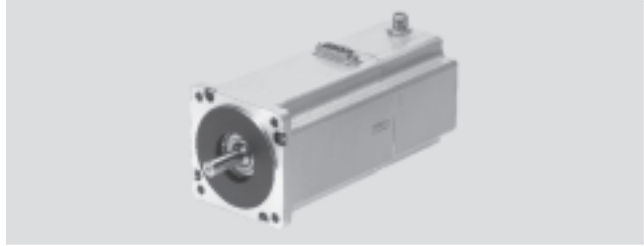

General technical data		
Size		42
Motor		
Nominal voltage	[V DC]	48
Nominal current	[A]	1.8
Holding torque	[Nm]	0.5
Stepper angle	[°]	1.8 ±5%
Winding resistance	[Ω]	1.75 ±10%
Winding inductance	[mH]	5.4
Drive mass moment of inertia	[kgcm ²]	0.082/0.095 ¹⁾
Radial load on shaft	[N]	20
Axial load on shaft	[N]	7
Mass moment of inertia of rotor	[kgcm ²]	0.082
Brake		
Operating voltage	[V DC]	24 ±10%
Output	[W]	8
Holding torque	[Nm]	0.4
Mass moment of inertia	[kgcm ²]	0.013

1) With brake

Size		57-S	57-M
Motor			
Nominal voltage	[V DC]	48	
Nominal current	[A]	5	
Holding torque	[Nm]	0.8	1.4
Stepper angle	[°]	1.8 ±5%	
Winding resistance	[Ω]	0.15 ±10%	0.25 ±10%
Winding inductance	[mH]	0.5	0.95
Drive mass moment of inertia	[kgcm ²]	0.29/0.30 ¹⁾	0.48/0.5 ¹⁾
Radial load on shaft	[N]	52	
Axial load on shaft	[N]	10	
Mass moment of inertia of rotor	[kgcm ²]	0.29	0.48
Brake			
Operating voltage	[V DC]	24 ±10%	
Output	[W]	8	10
Holding torque	[Nm]	0.4	1
Mass moment of inertia	[kgcm ²]	0.01	0.02

1) With brake

Stepper motors EMMS-ST

Technical data

FESTO

General technical data				
Size		87-S	87-M	87-L
Motor				
Nominal voltage	[V DC]	48		
Nominal current	[A]	9.5		
Holding torque	[Nm]	2.5	5.9	9.3
Stepper angle	[°]	1.8 ±5%		
Winding resistance	[Ω]	0.1 ±10%	0.23 ±10%	0.23 ±10%
Winding inductance	[mH]	0.45	2.6	2.7
Drive mass moment of inertia	[kgcm ²]	1/1.07 ¹⁾	1.9/1.97 ¹⁾	3/3.07 ¹⁾
Radial load on shaft	[N]	200		
Axial load on shaft	[N]	65		
Mass moment of inertia of rotor	[kgcm ²]	1	1.9	3
Brake				
Operating voltage	[V DC]	24 ±10%		
Output	[W]	11		
Holding torque	[Nm]	2		
Mass moment of inertia	[kgcm ²]	0.07		

1) With brake

Technical data – Encoder		
Encoder, optical		
Operating voltage	[V DC]	5
Pulses/revolution	[rpm]	500
Zero pulse		Yes
Line driver		RS422 protocol

Weight [g]						
Size	42	57-S	57-M	87-S	87-M	87-L
Product weight	360	870	1,100	1,950	3,050	4,200
With encoder	450	970	1,200	2,100	3,200	4,350
With brake	540	1,090	1,320	2,350	3,450	4,600
With encoder and brake	600	1,150	1,380	2,500	3,600	5,000

Operating and environmental conditions	
Insulation protection class to VDE 60034	B
Protection class	IP54
Ambient temperature	[°C] -10 ... +50
Storage temperature	[°C] -20 ... +70
CE mark (see declaration of conformity)	In accordance with EU EMC directive
Relative air humidity (non-condensing)	[%] 45 ... 80

Stepper motors EMMS-ST

Technical data

Pin allocation

Motor connection

Size 42, 57

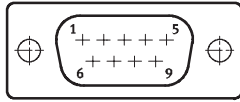

PIN	Function
1	String A
2	String A/
3	String B
4	String B/
5	-
6	-
7	Brake (24 V)
8	Brake (0 V)
9	-

Size 87

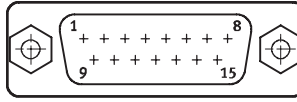

PIN	Function
1	String A
2	String A
3	String A/
4	String A/
5	String B
6	String B
7	String B/
8	String B/
9	-
10	-
11	Brake (24 V)
12	Brake (0 V)
13	-
14	-
15	-

Encoder connection

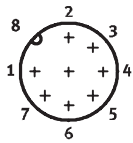

PIN	Function
1	Signal trace A
2	Signal trace A/
3	Signal trace B
4	Signal trace B/
5	0 V
6	Signal trace N
7	Signal trace N/
8	5 V

Stepper motors EMMS-ST

Technical data

Torque M as a function of rotational speed n

EMMS-ST-42

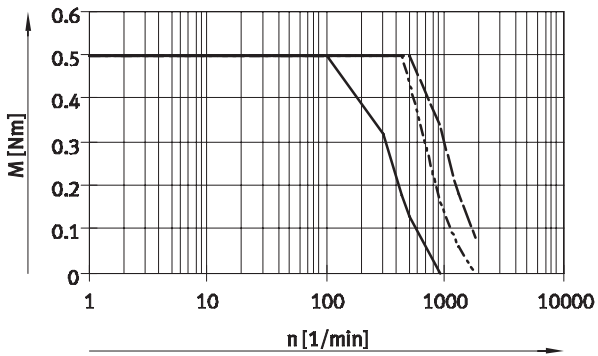

EMMS-ST-57-S

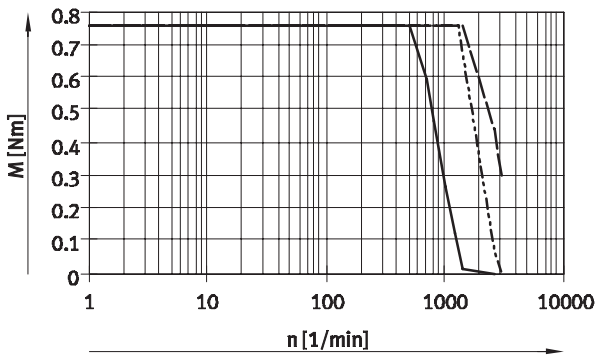

EMMS-ST-57-M

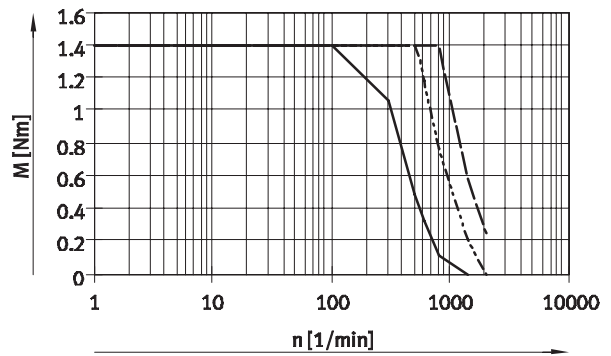

EMMS-ST-87-S

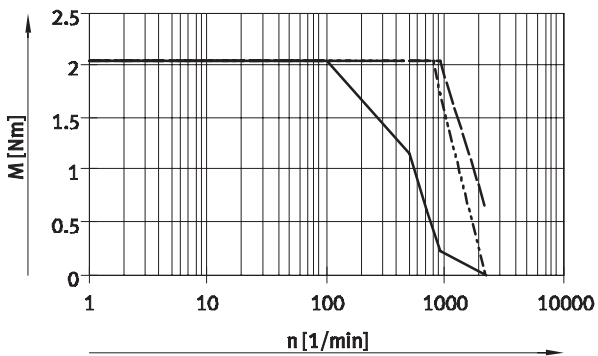

EMMS-ST-87-M

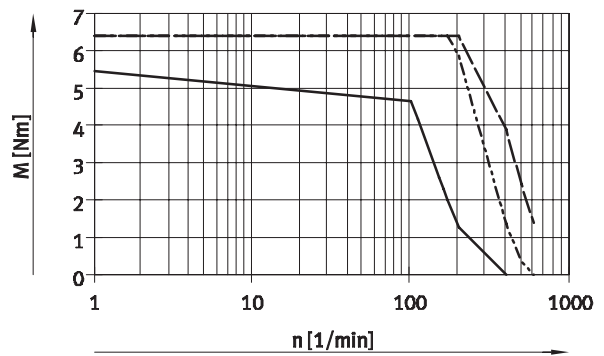

EMMS-ST-87-L

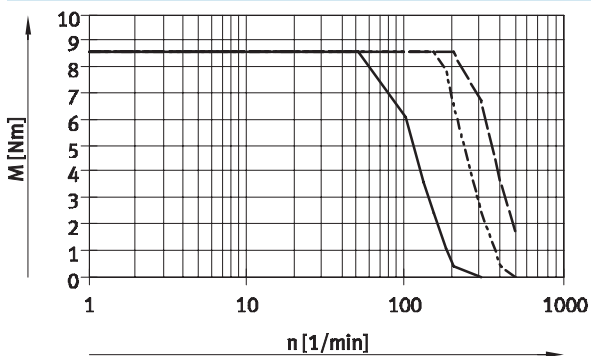

— 24VDC
 - - - 48VDC
 - · - 72VDC



Note

The characteristic curves apply in combination with the motor controller CMMS-ST. The size EMMS-ST-87 is operated with the motor controller CMMS-ST with max. 8 A.

Stepper motors EMMS-ST

Technical data

Dimensions

Download CAD data → www.festo.com/en/engineering

EMMS-ST-...-S

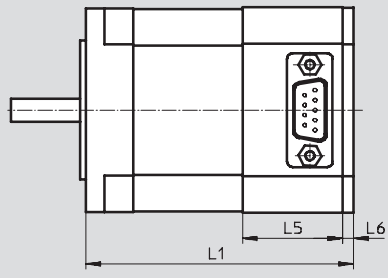

EMMS-ST-...-SB

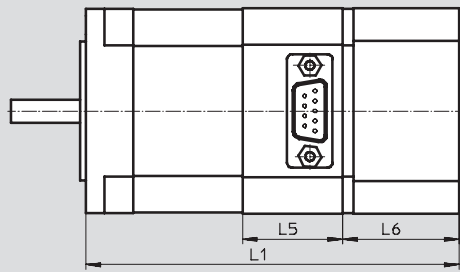

EMMS-ST-...-SE/SEB

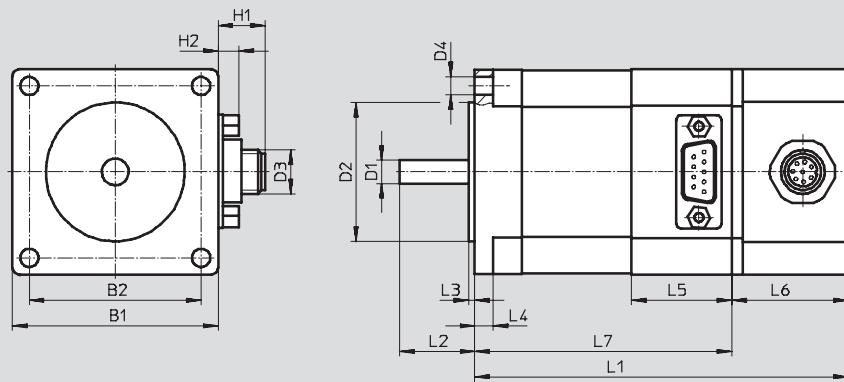

Plug assignment

9-pin Sub-D plug
with size 42, 57

15-pin Sub-D plug
with size 87

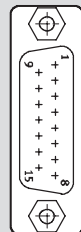
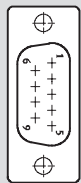

Stepper motors EMMS-ST

Technical data

FESTO

Type	B1	B2	D1 ∅	D2 ∅	D3	D4 ∅	H1	H2
EMMS-ST-42-S-S	42.3	31	5-0.012	22-0.05	-	M3x4.5	-	6.5
EMMS-ST-42-S-SE					M12		13	
EMMS-ST-42-S-SB					-		-	
EMMS-ST-42-S-SEB					M12		13	
EMMS-ST-57-S-S	56.4	47.14	6.35-0.013	38.1±0.025	-	5	-	
EMMS-ST-57-S-SE					M12		13	
EMMS-ST-57-S-SB					-		-	
EMMS-ST-57-S-SEB					M12		13	
EMMS-ST-57-M-S	56.4	47.14	6.35-0.013	38.1±0.025	-	5	-	
EMMS-ST-57-M-SE					M12		13	
EMMS-ST-57-M-SB					-		-	
EMMS-ST-57-M-SEB					M12		13	
EMMS-ST-87-S-S	85.6	69.5	11-0.013	73-0.046	-	6.6	-	
EMMS-ST-87-S-SE					M12		13	
EMMS-ST-87-S-SB					-		-	
EMMS-ST-87-S-SEB					M12		13	
EMMS-ST-87-M-S					-		-	
EMMS-ST-87-M-SE					M12		13	
EMMS-ST-87-M-SB					-		-	
EMMS-ST-87-M-SEB					M12		13	
EMMS-ST-87-L-S					-		-	
EMMS-ST-87-L-SE					M12		13	
EMMS-ST-87-L-SB					-		-	
EMMS-ST-87-L-SEB					M12		13	

Type	L1	L2	L3	L4	L5	L6	L7
EMMS-ST-42-S-S	66	24±1	2	-	24	2	-
EMMS-ST-42-S-SE	94					30	64±1
EMMS-ST-42-S-SB	114					50	
EMMS-ST-42-S-SEB	127					63	
EMMS-ST-57-S-S	73.5	20.6±0.5	1.6	5	27.5	3	
EMMS-ST-57-S-SE	102.5					32	70.5±0.8
EMMS-ST-57-S-SB	123.5					53	
EMMS-ST-57-S-SEB	138					64.5	
EMMS-ST-57-M-S	95	20.6±0.5	1.6	5	27.5	3	
EMMS-ST-57-M-SE	124					32	92±0.8
EMMS-ST-57-M-SB	145					53	
EMMS-ST-57-M-SEB	159.5					67.5	
EMMS-ST-87-S-S	82.6	27±1	2	8.38	31.4	3	
EMMS-ST-87-S-SE	112.6					33	79.6±1
EMMS-ST-87-S-SB	132.6					53	
EMMS-ST-87-S-SEB	152.6					73	
EMMS-ST-87-M-S	114.9	27±1	2	8.38	31.4	3	
EMMS-ST-87-M-SE	144.9					33	111.9±1
EMMS-ST-87-M-SB	164.9					53	
EMMS-ST-87-M-SEB	184.9					73	
EMMS-ST-87-L-S	144.9	27±1	2	8.38	31.4	3	
EMMS-ST-87-L-SE	174.9					33	141.9±1
EMMS-ST-87-L-SB	194.9					53	
EMMS-ST-87-L-SEB	214.9					73	

Stepper motors EMMS-ST

Technical data

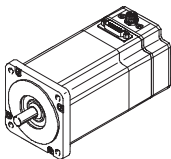
Ordering data						
	Size	Variant			Part No.	Type
		Basic version	With encoder	With brake		
	42	<input checked="" type="checkbox"/>			549 404	EMMS-ST-42-S-S
			<input checked="" type="checkbox"/>		549 405	EMMS-ST-42-S-SE
				<input checked="" type="checkbox"/>	549 406	EMMS-ST-42-S-SB
			<input checked="" type="checkbox"/>	<input checked="" type="checkbox"/>	549 407	EMMS-ST-42-S-SEB
	57	<input checked="" type="checkbox"/>			549 408	EMMS-ST-57-S-S
			<input checked="" type="checkbox"/>		549 409	EMMS-ST-57-S-SE
				<input checked="" type="checkbox"/>	549 410	EMMS-ST-57-S-SB
			<input checked="" type="checkbox"/>	<input checked="" type="checkbox"/>	549 411	EMMS-ST-57-S-SEB
		<input checked="" type="checkbox"/>			549 412	EMMS-ST-57-M-S
			<input checked="" type="checkbox"/>		549 413	EMMS-ST-57-M-SE
				<input checked="" type="checkbox"/>	549 414	EMMS-ST-57-M-SB
			<input checked="" type="checkbox"/>	<input checked="" type="checkbox"/>	549 415	EMMS-ST-57-M-SEB
	87	<input checked="" type="checkbox"/>			549 416	EMMS-ST-87-S-S
			<input checked="" type="checkbox"/>		549 417	EMMS-ST-87-S-SE
				<input checked="" type="checkbox"/>	549 418	EMMS-ST-87-S-SB
			<input checked="" type="checkbox"/>	<input checked="" type="checkbox"/>	549 419	EMMS-ST-87-S-SEB
		<input checked="" type="checkbox"/>			549 420	EMMS-ST-87-M-S
			<input checked="" type="checkbox"/>		549 421	EMMS-ST-87-M-SE
				<input checked="" type="checkbox"/>	549 422	EMMS-ST-87-M-SB
			<input checked="" type="checkbox"/>	<input checked="" type="checkbox"/>	549 423	EMMS-ST-87-M-SEB
		<input checked="" type="checkbox"/>			549 424	EMMS-ST-87-L-S
		<input checked="" type="checkbox"/>		549 425	EMMS-ST-87-L-SE	
			<input checked="" type="checkbox"/>	549 426	EMMS-ST-87-L-SB	
		<input checked="" type="checkbox"/>	<input checked="" type="checkbox"/>	549 427	EMMS-ST-87-L-SEB	

Stepper motors EMMS-ST

Accessories

FESTO

Gear unit EMGA

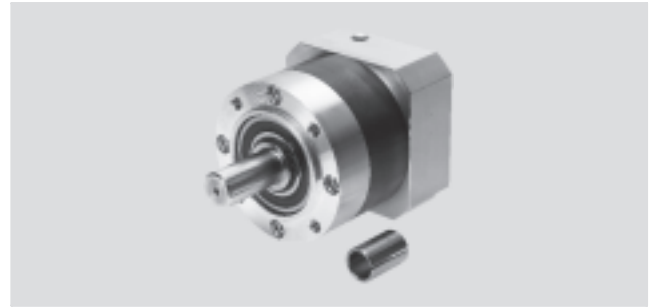

General technical data							
For motor size		42		57		87	
Gear unit type		EMGA-40-P-G...		EMGA-60-P-G...		EMGA-80-P-G...	
Gear reduction ratio	[i]	3	5	3	5	3	5
Continuous output torque ¹⁾	[Nm]	11	14	22	22	85	110
Max. drive torque	[Nm]	17.6	22	22	22	136	176
Torsional resistance	[Nm/arcmin]	1		2.3		6	
Torsional backlash	[arcmin]	< 24		< 16		< 9	
Moment of inertia ²⁾	[kgcm ²]	0.031	0.19	0.135	0.078	0.77	0.45
Efficiency	[%]	96					
Operating temperature ³⁾	[°C]	-25 ... +90					
Protection class		IP54					

- 1) At the drive shaft
- 2) Referred to the drive shaft
- 3) Note the temperature range of the motor

Dimensions Download CAD data → www.festo.com/en/engineering

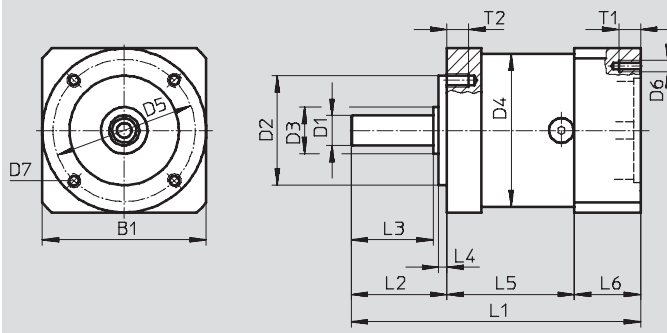

For size	B1	D1 ∅ h7	D2 ∅ h7	D3 ∅	D4 ∅	D5 ∅	D6	D7	L1 ±1.5	L2	L3 ±0.2	L4 ±0.2	L5	L6	T1	T2
42	40	10	26	12	40	34	∅3.4	M4	92.5	26±0.6	23	2	39	27.5	5	6
57	60	11	40	17	60	52	M4	M5	106	35±0.8	30	3	47	24	8	8
87	90	20	60	25	80	70	M5	M6	135.5	40±0.8	36	3	60	35.5	12	10

Ordering data			
For size	Reduction	Part No.	Type
42	3	549 428	EMGA-40-P-G3-SST-42
	5	549 429	EMGA-40-P-G5-SST-42
57	3	549 430	EMGA-60-P-G3-SST-57
	5	549 431	EMGA-60-P-G5-SST-57
87	3	549 432	EMGA-80-P-G3-SST-87
	5	549 433	EMGA-80-P-G5-SST-87

Stepper motors EMMS-ST

Accessories

Technical data – Cables			
Designation	Motor cable		Encoder cable
Type	NEBM-S1G9-...	NEBM-S1G15-...	NEBM-M12G8-...
For size	EMMS-ST-42/57	EMMS-ST-87	EMMS-ST-42/57/87
Min. bending radius [mm]	58	70	51
Ambient temperature [°]	-40 ... +70	-30 ... +70	-40 ... +70
Ambient temperature ¹⁾ [°]	-40 ... +70	-5 ... +70	-40 ... +70
Cable design	Screened		
Cable attribute	Suitable for drag chain		
Protection class	IP65		
Material	Polyurethane		

1) with flexible cable installation

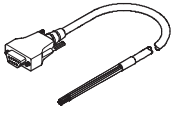
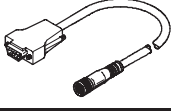
Ordering data			
	Cable length [m]	Part No.	Type
Motor cable			
	For EMMS-ST-42/57		
	5	550 740	NEBM-S1G9-E-5-LE6
	10	550 741	NEBM-S1G9-E-10-LE6
	15	550 742	NEBM-S1G9-E-15-LE6
	X length ¹⁾	550 743	NEBM-S1G9-E-...-LE6
	For EMMS-ST-87		
	5	550 744	NEBM-S1G15-E-5-LE6
	10	550 745	NEBM-S1G15-E-10-LE6
	15	550 746	NEBM-S1G15-E-15-LE6
	X length ¹⁾	550 747	NEBM-S1G15-E-...-LE6
Encoder cable			
	5	550 748	NEBM-M12G8-E-5-S1G9
	10	550 749	NEBM-M12G8-E-10-S1G9
	15	550 750	NEBM-M12G8-E-15-S1G9
	X length ¹⁾	550 751	NEBM-M12G8-E-...-S1G9

1) Max. 25 m