

- High performance
- Digital absolute displacement encoder, single turn or multi-turn
- Simple commissioning
- Optimised connection technology
- Harmonised motor/controller combinations

## Servo motors EMMS-AS

Key features

### Everything from a single source

Motors EMMS-AS

→ 42



- Permanently excited, electro-dynamic, brushless servo motor
- Choice of two encoder types:
  - Digital single-turn absolute displacement encoder (standard)
  - Digital multi-turn absolute displacement encoder (optional)
- Optionally with holding brake
- Protection class:
  - IP54 (motor shaft)
  - IP65 (motor housing with connection technology)
- Optimised connection technology:
  - With size 40, 55: Terminal connection
  - With size 70, 100, 140: Round plug: M23 power connection, rotatable M12 encoder connection

### Gear unit EMGA-SAS

→ 50



- Spur toothed planetary gearing
- Gear reduction = 3:1 and 5:1, available ex-stock
- Life time lubrication
- Protection class: IP54

### Motor controller CMMP-AS

→ 5 / 2.2-85



- Digital servo controller in 4 performance classes (0.5 kVA ... 6 kVA)
- Actuation of AC servo and linear motors
- Integrated EMC filters
- Integrated brake chopper
- Integrated safety functions
- Position controller with closed-loop position control (256 position sets)
- Speed controller
- Torque control via current controller
- Range of control functions
- Interfaces:
  - I/O interface
  - CANopen, standard
  - Profibus DP, optional module
  - DeviceNet, optional module
  - Sercos 2, optional module

### Motor and encoder cables NEBM

→ 52

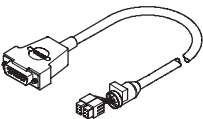

- Can be used in a wide temperature range
- Suitable for chain link trunking
- Protection class IP65

### Axial and parallel kits EAMM

→ [www.festo.com](http://www.festo.com)



- Specified kits for all electro-mechanical axes from Festo
- Each kit includes the relevant necessary coupling housing, couplings and motor flange as well as all screws

# Servo motors EMMS-AS

Type codes

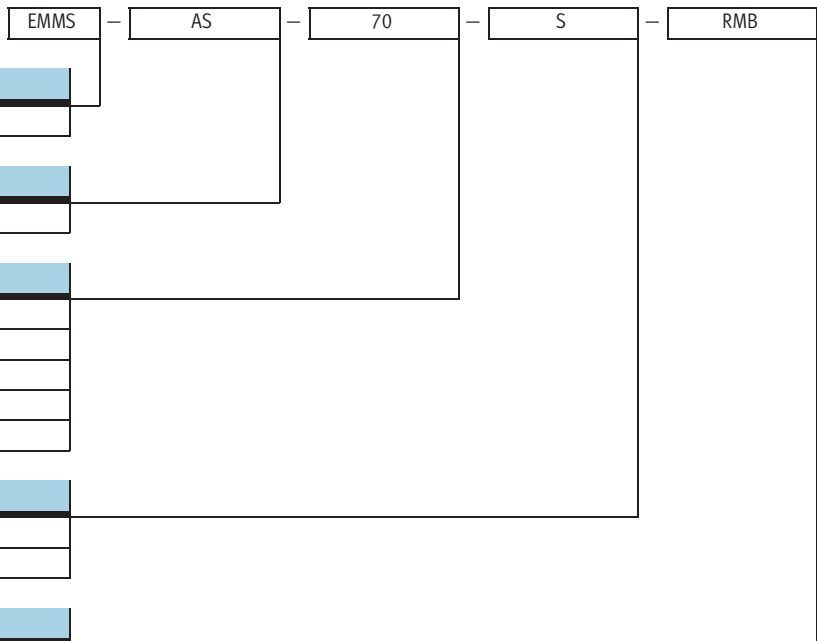

**Type**

EMMS	Motor
------	-------

**Motor type**

AS	Servo motor
----	-------------

**Flange dimensions**

40	40 mm
55	55 mm
70	70 mm
100	100 mm
140	140 mm

**Overall length options**

S	Small
M	Medium

**Additional function**

T	Terminal connection
R	Round plug
S	Single turn
M	Multi-turn
B	Brake

## Servo motors EMMS-AS

Technical data

**FESTO**



General technical data			
Size		40	55
<b>Motor</b>			
Nominal voltage	[V DC]	360	360
Nominal current	[A]	0.6	1.2
Peak current	[A]	3.3	5
Rated output	[W]	222	467
Nominal torque	[Nm]	0.2	0.68
Peak torque	[Nm]	1	2.7
Torque at standstill	[Nm]	0.26	0.98
Nominal speed	[rpm]	10,300	6,600
Max. speed	[rpm]	11,180	7,330
Motor constant	[Nm/A]	0.344	0.558
Winding resistance	[Ω]	34.833	14.35
Winding inductance	[mH]	10.36	13.83
Drive mass moment of inertia	[kgcm <sup>2</sup> ]	0.054	0.223
Drive mass moment of inertia with brake	[kgcm <sup>2</sup> ]	0.064	0.245
Radial load on shaft	[N]	82	150
Axial load on shaft	[N]	12	75
<b>Brake</b>			
Operating voltage	[V DC]	24 ±10%	24 +6 ... -10%
Output	[W]	6.2	10
Holding torque	[Nm]	0.4	0.8
Mass moment of inertia	[kgcm <sup>2</sup> ]	0.01	0.022

Size		70-S	70-M
<b>Motor</b>			
Nominal voltage	[V DC]	360	360
Nominal current	[A]	2.2	2.6
Peak current	[A]	5	10
Rated output	[W]	866	1 061
Nominal torque	[Nm]	1.43	2.29
Peak torque	[Nm]	3.1	7.75
Torque at standstill	[Nm]	1.64	2.56
Nominal speed	[rpm]	5,300	4,100
Max. speed	[rpm]	6,300	4,780
Motor constant	[Nm/A]	0.647	0.864
Winding resistance	[Ω]	7.66	6.71
Winding inductance	[mH]	0.015	0.013
Drive mass moment of inertia	[kgcm <sup>2</sup> ]	0.379	0.611
Drive mass moment of inertia with brake	[kgcm <sup>2</sup> ]	0.449	0.68
Radial load on shaft	[N]	150	200
Axial load on shaft	[N]	75	75
<b>Brake</b>			
Operating voltage	[V DC]	24 +6 ... -10%	24 +6 ... -10%
Output	[W]	11	11
Holding torque	[Nm]	2	2
Mass moment of inertia	[kgcm <sup>2</sup> ]	0.071	0.073

## Servo motors EMMS-AS

Technical data

General technical data				
Size		100-S		100-M
<b>Motor</b>				
Nominal voltage	[V DC]	360	565	565
Nominal current	[A]	3.8	3.3	3.4
Peak current	[A]	10	15	20
Rated output	[W]	1,497	1,573	2,015
Nominal torque	[Nm]	3.76	3.24	5.69
Peak torque	[Nm]	9.2	12.5	22.1
Torque at standstill	[Nm]	4.71		8.09
Nominal speed	[rpm]	3,500	4,600	3,400
Max. speed	[rpm]	5,950		3,750
Motor constant	[Nm/A]	0.984		1.652
Winding resistance	[Ω]	2.92		3.18
Winding inductance	[mH]	0.009		0.111
Drive mass moment of inertia	[kgcm <sup>2</sup> ]	2.529		4.729
Drive mass moment of inertia with brake	[kgcm <sup>2</sup> ]	3.085		5.285
Radial load on shaft	[N]	300		570
Axial load on shaft	[N]	150		150
<b>Brake</b>				
Operating voltage	[V DC]	24 +6 ... -10%		24 +6 ... -10%
Output	[W]	18		18
Holding torque	[Nm]	9		9
Mass moment of inertia	[kgcm <sup>2</sup> ]	0.555		0.555

Size		140-S		140-M
<b>Motor</b>				
Nominal voltage	[V DC]	565		565
Nominal current	[A]	4.4		7.4
Peak current	[A]	15		20
Rated output	[W]	2,663		4,827
Nominal torque	[Nm]	9.55		20.05
Peak torque	[Nm]	25.6		48.8
Torque at standstill	[Nm]	11.32		25.48
Nominal speed	[rpm]	2,600		2,000
Max. speed	[rpm]	2,930		2,210
Motor constant	[Nm/A]	2.166		2.72
Winding resistance	[Ω]	3.31		1.442
Winding inductance	[mH]	0.02		0.013
Drive mass moment of inertia	[kgcm <sup>2</sup> ]	8.189		19.027
Drive mass moment of inertia with brake	[kgcm <sup>2</sup> ]	9.271		20.108
Radial load on shaft	[N]	780		1,060
Axial load on shaft	[N]	200		200
<b>Brake</b>				
Operating voltage	[V DC]	24 ±10%		24 ±10%
Output	[W]	15.6		15.6
Holding torque	[Nm]	18		18
Mass moment of inertia	[kgcm <sup>2</sup> ]	1.082		1.082

## Servo motors EMMS-AS

Technical data



Technical data – Encoder		
Type	EMMS-AS-...-...S... Absolute, single turn	EMMS-AS-...-...M... Absolute, multi-turn
Digital encoder, inductive		
Operating voltage [V DC]	5	
Protocol	EnDat 2.2	
Version	Standard	Optional
Resolution	65,536 position values within one revolution (360°), 16 bit	
	–	– 4,096 revolutions, 12 bit – Battery-free system

Weight [g]								
Size	42	55	70-S	70-M	100-S	100-M	140-S	140-M
Product weight	1,000	1,600	2,100	2,700	4,800	6,900	9,600	16,200
With brake	1,050	1,700	2,300	2,900	5,300	7,500	10,400	17,000

Operating and environmental conditions	
Protection class	IP54
Ambient temperature [°C]	–10 ... +40 (up to 130°C with derating)
Storage temperature [°C]	–20 ... +60
Insulation protection class to EN 60034	F
Rated class to EN 60034-1	S1
Heat class to EN 60034-1	F
CE symbol (see declaration of conformity)	In accordance with EU EMC directive
Certification	C-UL-US recognised (OL)
Relative air humidity (non-condensing) [%]	0 ... 90
Corrosion resistance class CRC <sup>1)</sup>	2

- 1) Corrosion resistance class 2 to Festo standard 940 070  
Components subject to moderate corrosion stress. Externally visible parts with primarily decorative surface requirements which are in direct contact with a normal industrial environment or media such as coolants or lubricating agents.

# Servo motors EMMS-AS

Technical data

**Pin allocation**  
 Sizes 40, 55  
 Motor, output

Black plug	Encoder Red plug	Encoder Yellow plug	Temperature sensor and holding brake Blue plug																																																								
<table border="1"> <thead> <tr> <th>PIN</th> <th>Function</th> </tr> </thead> <tbody> <tr><td>1</td><td>Phase V</td></tr> <tr><td>2</td><td>Phase W</td></tr> <tr><td>3</td><td>Phase U</td></tr> <tr><td>4</td><td>PE (protective earth)</td></tr> <tr><td></td><td></td></tr> <tr><td></td><td></td></tr> </tbody> </table>	PIN	Function	1	Phase V	2	Phase W	3	Phase U	4	PE (protective earth)					<table border="1"> <thead> <tr> <th>PIN</th> <th>Function</th> </tr> </thead> <tbody> <tr><td>1</td><td>DATA</td></tr> <tr><td>2</td><td>DATA/</td></tr> <tr><td>3</td><td>0 V</td></tr> <tr><td>4</td><td>UP</td></tr> <tr><td>5</td><td>CLOCK</td></tr> <tr><td>6</td><td>CLOCK/</td></tr> </tbody> </table>	PIN	Function	1	DATA	2	DATA/	3	0 V	4	UP	5	CLOCK	6	CLOCK/	<table border="1"> <thead> <tr> <th>PIN</th> <th>Function</th> </tr> </thead> <tbody> <tr><td>1</td><td>-SENS</td></tr> <tr><td>2</td><td>+SENS</td></tr> <tr><td>3</td><td>-</td></tr> <tr><td>4</td><td>-</td></tr> <tr><td>5</td><td>-</td></tr> <tr><td>6</td><td>-</td></tr> </tbody> </table>	PIN	Function	1	-SENS	2	+SENS	3	-	4	-	5	-	6	-	<table border="1"> <thead> <tr> <th>PIN</th> <th>Function</th> </tr> </thead> <tbody> <tr><td>1</td><td>Temperature sensor M<sub>T</sub>+</td></tr> <tr><td>2</td><td>Temperature sensor M<sub>T</sub>-</td></tr> <tr><td>3</td><td>Holding brake BR+</td></tr> <tr><td>4</td><td>Holding brake BR-</td></tr> <tr><td>5</td><td>-</td></tr> <tr><td>6</td><td>-</td></tr> </tbody> </table>	PIN	Function	1	Temperature sensor M <sub>T</sub> +	2	Temperature sensor M <sub>T</sub> -	3	Holding brake BR+	4	Holding brake BR-	5	-	6	-
PIN	Function																																																										
1	Phase V																																																										
2	Phase W																																																										
3	Phase U																																																										
4	PE (protective earth)																																																										
PIN	Function																																																										
1	DATA																																																										
2	DATA/																																																										
3	0 V																																																										
4	UP																																																										
5	CLOCK																																																										
6	CLOCK/																																																										
PIN	Function																																																										
1	-SENS																																																										
2	+SENS																																																										
3	-																																																										
4	-																																																										
5	-																																																										
6	-																																																										
PIN	Function																																																										
1	Temperature sensor M <sub>T</sub> +																																																										
2	Temperature sensor M <sub>T</sub> -																																																										
3	Holding brake BR+																																																										
4	Holding brake BR-																																																										
5	-																																																										
6	-																																																										

Sizes 70, 100, 140  
 Motor

Motor	Encoder																																				
<table border="1"> <thead> <tr> <th>PIN</th> <th>Function</th> </tr> </thead> <tbody> <tr><td>1</td><td>Phase U</td></tr> <tr><td>2</td><td>PE (protective earth)</td></tr> <tr><td>3</td><td>Phase W</td></tr> <tr><td>4</td><td>Phase V</td></tr> <tr><td>A</td><td>Temperature sensor M<sub>T</sub>+</td></tr> <tr><td>B</td><td>Temperature sensor M<sub>T</sub>-</td></tr> <tr><td>C</td><td>Holding brake BR+</td></tr> <tr><td>D</td><td>Holding brake BR-</td></tr> </tbody> </table>	PIN	Function	1	Phase U	2	PE (protective earth)	3	Phase W	4	Phase V	A	Temperature sensor M <sub>T</sub> +	B	Temperature sensor M <sub>T</sub> -	C	Holding brake BR+	D	Holding brake BR-	<table border="1"> <thead> <tr> <th>PIN</th> <th>Function</th> </tr> </thead> <tbody> <tr><td>1</td><td>-SENS</td></tr> <tr><td>2</td><td>+SENS</td></tr> <tr><td>3</td><td>DATA</td></tr> <tr><td>4</td><td>DATA/</td></tr> <tr><td>5</td><td>0 V</td></tr> <tr><td>6</td><td>CLOCK/</td></tr> <tr><td>7</td><td>CLOCK</td></tr> <tr><td>8</td><td>UP</td></tr> </tbody> </table>	PIN	Function	1	-SENS	2	+SENS	3	DATA	4	DATA/	5	0 V	6	CLOCK/	7	CLOCK	8	UP
PIN	Function																																				
1	Phase U																																				
2	PE (protective earth)																																				
3	Phase W																																				
4	Phase V																																				
A	Temperature sensor M <sub>T</sub> +																																				
B	Temperature sensor M <sub>T</sub> -																																				
C	Holding brake BR+																																				
D	Holding brake BR-																																				
PIN	Function																																				
1	-SENS																																				
2	+SENS																																				
3	DATA																																				
4	DATA/																																				
5	0 V																																				
6	CLOCK/																																				
7	CLOCK																																				
8	UP																																				

# Servo motors EMMS-AS

Technical data

## Torque M as a function of rotational speed n

EMMS-AS-40-M (intermediate circuit voltage = 360 V)

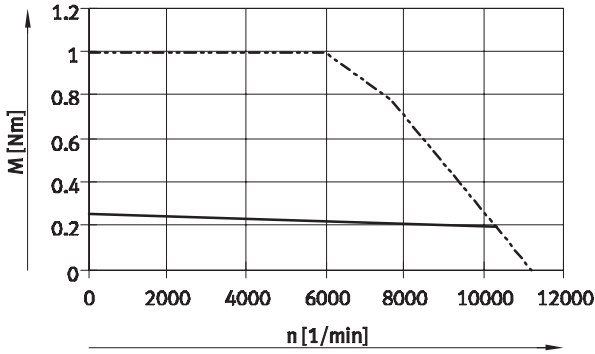

EMMS-AS-55-S (intermediate circuit voltage = 360 V)

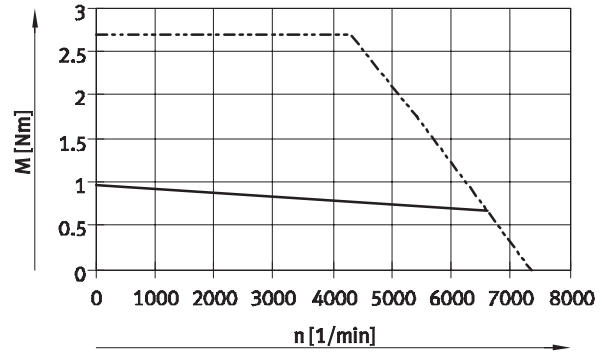

EMMS-AS-70-S (intermediate circuit voltage = 360 V)

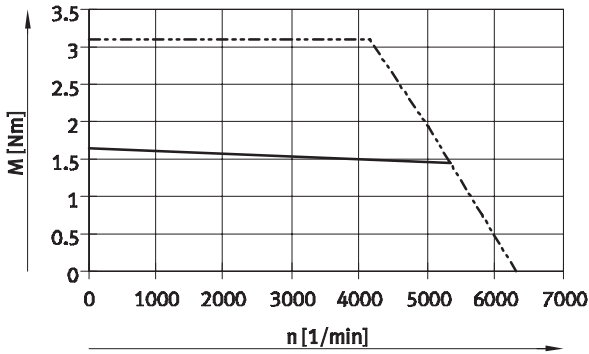

EMMS-AS-70-M (intermediate circuit voltage = 360 V)

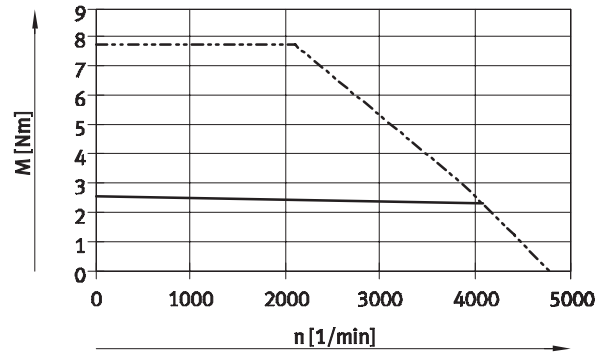

EMMS-AS-100-S (intermediate circuit voltage = 360 V)

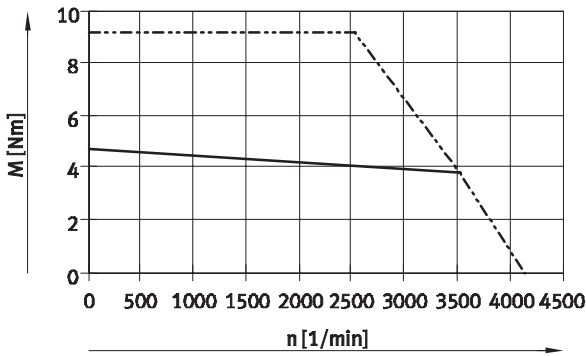

EMMS-AS-100-S (intermediate circuit voltage = 565 V)

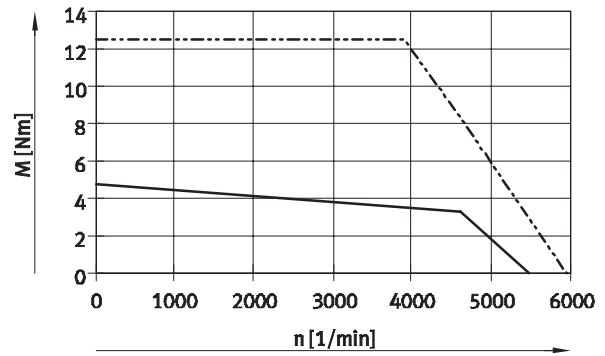

— Rated torque  
- - - Peak torque



# Servo motors EMMS-AS

Technical data



**Torque M as a function of rotational speed n**  
EMMS-AS-100-M (intermediate circuit voltage = 565 V)

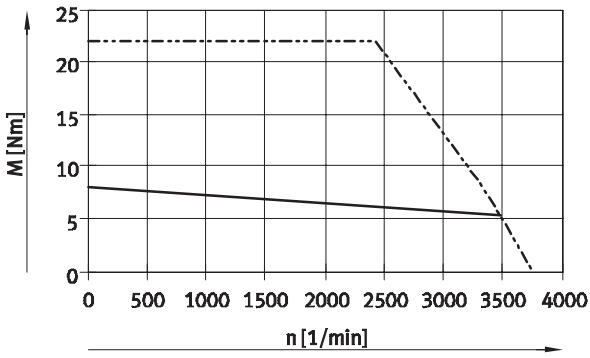

EMMS-AS-140-S (intermediate circuit voltage = 565 V)      EMMS-AS-140-M (intermediate circuit voltage = 565 V)

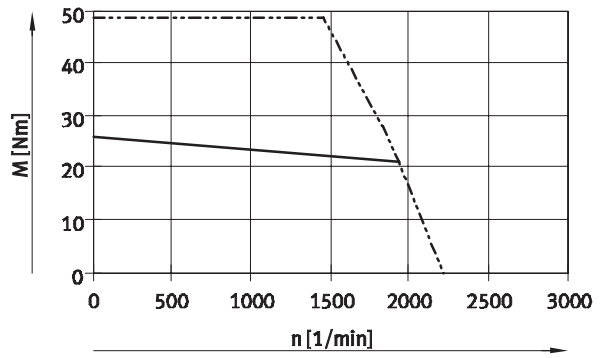
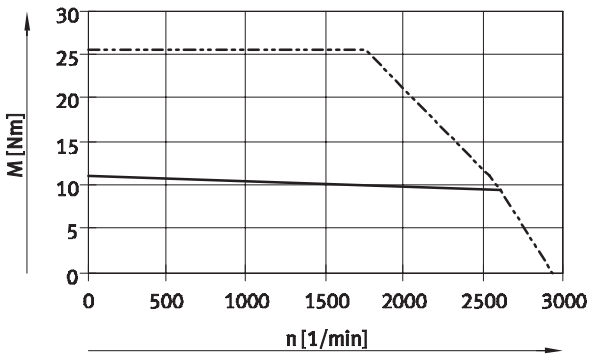

— Rated torque  
- - - Peak torque

# Servo motors EMMS-AS

Technical data

**Dimensions**

Download CAD data → [www.festo.com/en/engineering](http://www.festo.com/en/engineering)

Size 40

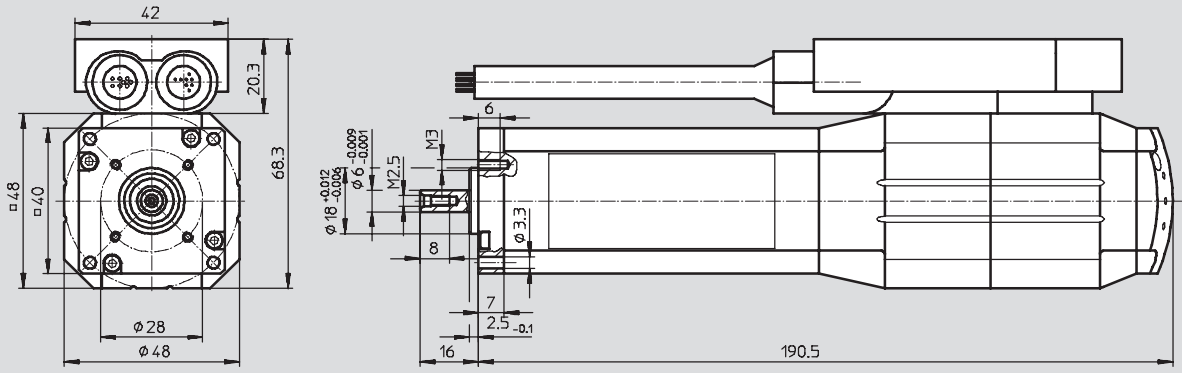

Size 55

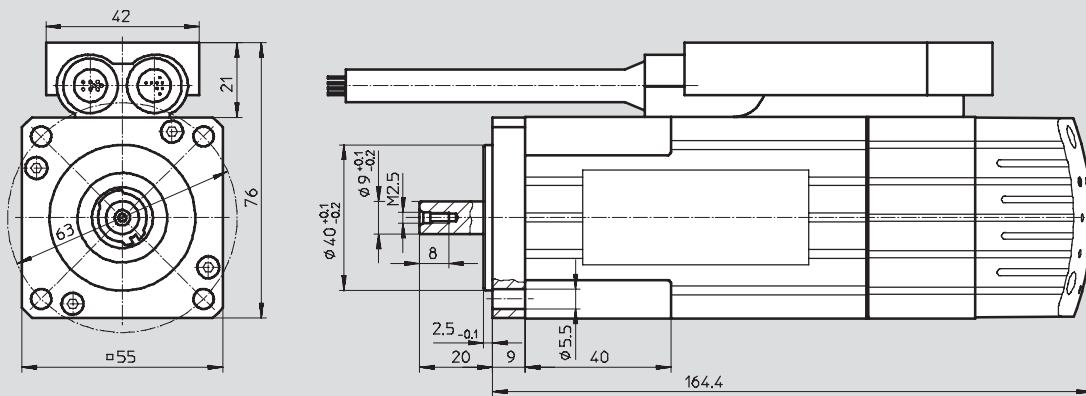

Sizes 70, 100, 140

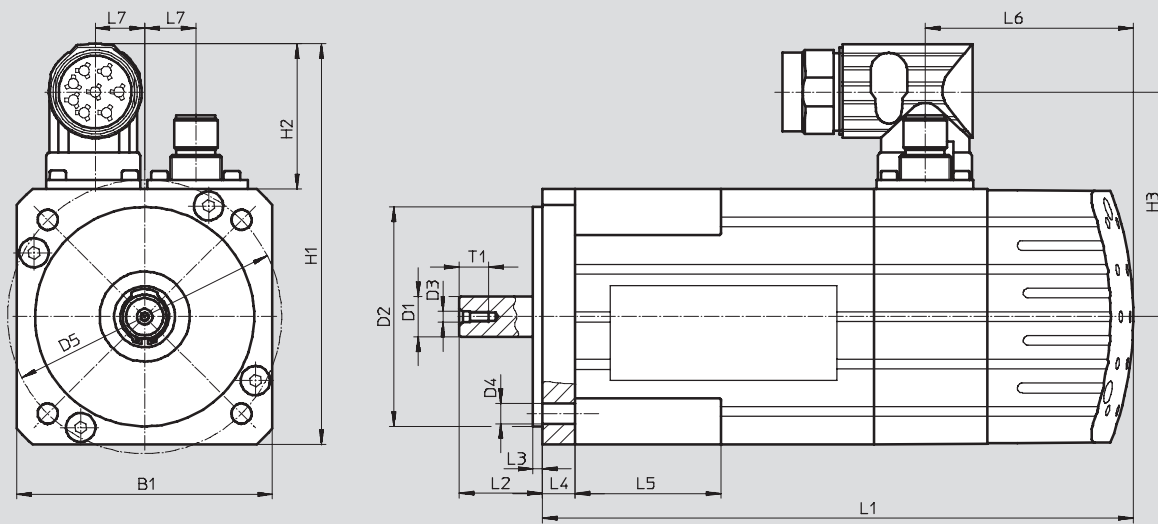

# Servo motors EMMS-AS

Technical data

FESTO

Size	Type	B1	D1 ∅	D2 ∅	D3	D4 ∅	D5 ∅	H1	H2
70	EMMS-AS-70-S	70	11	60	M2.5	5.5	75	109.5	39.5
	EMMS-AS-70-M		+0.012/+0.001	+0.012/+0.007					
100	EMMS-AS-100-S	100.5	19	95	M4	9.2	115	140	
	EMMS-AS-100-M		+0.015/+0.002	+0.013/-0.009					
140	EMMS-AS-140-S	140.5	24	130	M4	11.3	165	180	
	EMMS-AS-140-M		+0.015/+0.002	+0.018/-0.007					

Size	Type	H3	L1	L2	L3	L4	L5	L6	L7	T1
70	EMMS-AS-70-S	61.5	161.8	22.7	2.5 <sub>-0.1</sub>	9	40	57	14	8
	EMMS-AS-70-M		187.3							
100	EMMS-AS-100-S	77	192.3	40	3	9.8	-	58.9	19	16
	EMMS-AS-100-M		243.3							
140	EMMS-AS-140-S	97.7	209	50	3.5	12.2	-	58.6	33.5	16
	EMMS-AS-140-M		285.5							

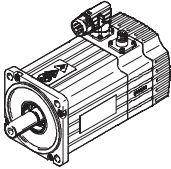
Ordering data		Variant					Part No.	Type	
Size	Variant	Single turn	Multi-turn	With brake	Small	Medium			
	40	■				■	550 106	EMMS-AS-40-M-TS	
			■				■	550 107	EMMS-AS-40-M-TM
		■		■			■	550 108	EMMS-AS-40-M-TSB
			■	■			■	550 109	EMMS-AS-40-M-TMB
	55	■				■		550 110	EMMS-AS-55-S-TS
			■			■		550 111	EMMS-AS-55-S-TM
		■		■	■	■		550 112	EMMS-AS-55-S-TSB
			■	■	■	■		550 113	EMMS-AS-55-S-TMB
		■				■		550 114	EMMS-AS-70-S-RS
	70		■			■		550 115	EMMS-AS-70-S-RM
		■		■	■	■		550 116	EMMS-AS-70-S-RSB
			■	■	■	■		550 117	EMMS-AS-70-S-RMB
		■					■	550 118	EMMS-AS-70-M-RS
			■				■	550 119	EMMS-AS-70-M-RM
				■	■	■	■	550 120	EMMS-AS-70-M-RSB
				■	■	■	■	550 121	EMMS-AS-70-M-RMB
		100	■				■		550 122
			■			■		550 123	EMMS-AS-100-S-RM
■			■	■	■		550 124	EMMS-AS-100-S-RSB	
	■		■	■	■		550 125	EMMS-AS-100-S-RMB	
■						■	550 127	EMMS-AS-100-M-RS	
	■					■	550 128	EMMS-AS-100-M-RM	
			■	■	■	■	550 129	EMMS-AS-100-M-RSB	
			■	■	■	■	550 130	EMMS-AS-100-M-RMB	
140	■				■		550 131	EMMS-AS-140-S-RS	
		■			■		550 132	EMMS-AS-140-S-RM	
	■		■	■	■		550 133	EMMS-AS-140-S-RSB	
		■	■	■	■		550 134	EMMS-AS-140-S-RMB	
	■					■	550 135	EMMS-AS-140-M-RS	
		■				■	550 136	EMMS-AS-140-M-RM	
			■	■	■	■	550 137	EMMS-AS-140-M-RSB	
			■	■	■	■	550 138	EMMS-AS-140-M-RMB	

# Servo motors EMMS-AS

Accessories



## Gear unit EMGA



General technical data									
For motor size		40		55		70			
Gear unit type		EMGA-40-P-G...-40		EMGA-60-P-G...-55		EMGA-60-P-G...-70		EMGA-80-P-G...-70	
Gear reduction ratio		3:1	5:1	3:1	5:1	3:1	5:1	3:1	5:1
Continuous driving torque <sup>1)</sup>	[Nm]	11	14	22	22	22	22	85	110
Max. driving torque <sup>2)</sup>	[Nm]	17.6	22	22	22	22	22	136	176
Torsional resistance	[Nm/arcmin]	1		2.3		2.3		6	
Torsional backlash	[arcmin]	< 24		< 16		< 16		< 9	
Moment of inertia <sup>3)</sup>	[kgcm <sup>2</sup> ]	0.031	0.19	0.135	0.078	0.135	0.078	0.77	0.45
Efficiency	[%]	96							
Operating temperature <sup>4)</sup>	[°C]	-25 ... +90							
Protection class		IP54							

For motor size		100		100		140			
Gear unit type		EMGA-80-P-G...-100		EMGA-120-P-G...-100		EMGA-120-P-G...-140		EMGA-160-P-G...-140	
Gear reduction ratio		3:1	5:1	3:1	5:1	3:1	5:1	3:1	5:1
Continuous driving torque <sup>1)</sup>	[Nm]	85	110	115	195	115	195	400	450
Max. driving torque <sup>2)</sup>	[Nm]	136	176	184	213	184	213	640	720
Torsional resistance	[Nm/arcmin]	6		12		12		38	
Torsional backlash	[arcmin]	< 9		< 8		< 8		< 6	
Moment of inertia <sup>3)</sup>	[kgcm <sup>2</sup> ]	0.77	0.45	2.63	1.53	2.63	1.53	12.14	6.07
Efficiency	[%]	96							
Operating temperature <sup>4)</sup>	[°C]	-25 ... +90							
Protection class		IP54							

- 1) At the drive shaft
- 2) The specifications refer to a drive shaft speed of 100 rpm as well as operating mode S1 and a temperature of 30 °C
- 3) In relation to the drive shaft
- 4) Note the temperature range of the motor

# Servo motors EMMS-AS

Accessories

FESTO

## Dimensions

Download CAD data → [www.festo.com/en/engineering](http://www.festo.com/en/engineering)

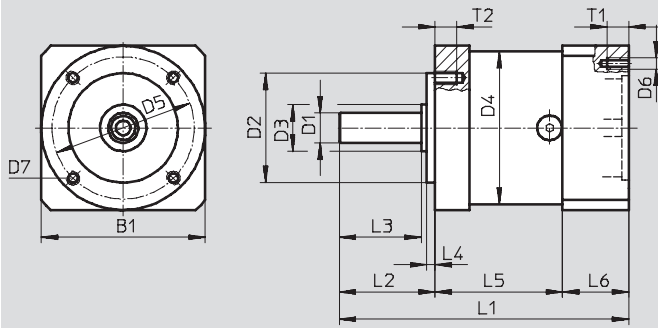

Type	B1	D1 ∅ h7	D2 ∅ h7	D3 ∅	D4 ∅	D5 ∅	D6	D7
EMGA-40-P-G...-40	40	10	26	12	40	34	M3	M4
EMGA-60-P-G...-55	60	11	40	17	60	52	M5	M5
EMGA-60-P-G...-70	70	11	40	17	60	52	M5	M5
EMGA-80-P-G...-70	80	20	60	25	80	70	M5	M6
EMGA-80-P-G...-100	100	20	60	25	80	70	M8	M6
EMGA-120-P-G...-100	115	25	80	35	115	100	M8	M10
EMGA-120-P-G...-140	140	25	80	35	115	100	M10	M10
EMGA-160-P-G...-140	140	40	130	55	160	145	M10	M12

Type	L1	L2	L3 ±0.2	L4 ±0.2	L5	L6	T1	T2
EMGA-40-P-G...-40	88.5±1.5	26±0.6	12	2	39	23.5	6	6
EMGA-60-P-G...-55	106±1.5	35±0.8	30	3	47	24	12	8
EMGA-60-P-G...-70	106±1.5	35±0.8	30	3	47	24	12	8
EMGA-80-P-G...-70	133.5±1.5	40±0.8	36	3	60	33.5	12	10
EMGA-80-P-G...-100	143.5±1.5	40±0.8	36	3	60	43.5	16	10
EMGA-120-P-G...-100	176.5±2	55±0.8	50	4	74	47.5	20	16
EMGA-120-P-G...-140	186±2	55±0.8	50	4	74	57.5	25	16
EMGA-160-P-G...-140	255.5±2	87±0.8	80	5	104	64.5	25	20

## Ordering data

For size	Reduction ratio	Part No.	Type
40	3	552 186	EMGA-40-P-G3-SAS-40
	5	552 187	EMGA-40-P-G5-SAS-40
55	3	552 188	EMGA-60-P-G3-SAS-55
	5	552 189	EMGA-60-P-G5-SAS-55
70	3	552 190	EMGA-60-P-G3-SAS-70
	5	552 191	EMGA-60-P-G5-SAS-70
	3	552 192	EMGA-80-P-G3-SAS-70
	5	552 193	EMGA-80-P-G5-SAS-70
100	3	552 194	EMGA-80-P-G3-SAS-100
	5	552 195	EMGA-80-P-G5-SAS-100
	3	552 196	EMGA-120-P-G3-SAS-100
	5	552 197	EMGA-120-P-G5-SAS-100
140	3	552 198	EMGA-120-P-G3-SAS-140
	5	552 199	EMGA-120-P-G5-SAS-140
	3	552 200	EMGA-160-P-G3-SAS-140
	5	552 201	EMGA-160-P-G5-SAS-140

# Servo motors EMMS-AS

Accessories

Technical data – Cables								
Designation	Motor cable				Encoder cable			
For size	EMMS-AS-40/55		EMMS-AS-70/100/140		EMMS-AS-40/55		EMMS-AS-70/100/140	
Type	NEBM-T1G7-...		NEBM-M23G6-...		NEBM-T1G8-...		NEBM-M12W8-...	
Plug colour/PIN	Black	Blue	1 ... 4	A ... D	Yellow	Red	1 ... 8	
Voltage [V]	630	48	630	300	30	30	30	
Current [A]	12	3	16	8	3	2	2	
Surge voltage [kV]	4	0.5	4	2.5	0.5	0.5	0.8	
Degree of contamination	3							
Min. bending radius [mm]	55		64		75		75	
Ambient temperature [°]	-40 ... +70		-40 ... +90		-40 ... +80		-40 ... +80	
Ambient temperature <sup>1)</sup> [°]	-50 ... +90		-50 ... +90		-10 ... +80		-10 ... +80	
Cable design	EMC optimised							
Cable attribute	Suitable for chain link trunking							
Protection class	IP65		IP67		IP65		IP65	
Material	Polyurethane							

1) With flexible cable installation

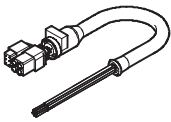
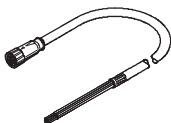
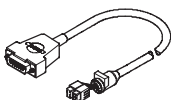
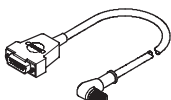
Ordering data			
	Cable length [m]	Part No.	Type
<b>Motor cable</b>			
	For EMMS-AS-40/55		
	5	550 306	NEBM-T1G7-E-5-N-LE7
	10	550 307	NEBM-T1G7-E-10-N-LE7
	15	550 308	NEBM-T1G7-E-15-N-LE7
	X length <sup>1)</sup>	550 309	NEBM-T1G7-E- -N-LE7
	For EMMS-AS-70/100/140		
	5	550 310	NEBM-M23G6-E-5-N-LE7
	10	550 311	NEBM-M23G6-E-10-N-LE7
	15	550 312	NEBM-M23G6-E-15-N-LE7
	X length <sup>1)</sup>	550 313	NEBM-M23G6-E- -N-LE7
<b>Encoder cable</b>			
	For EMMS-AS-40/55		
	5	550 314	NEBM-T1G8-E-5-N-S1G15
	10	550 315	NEBM-T1G8-E-10-N-S1G15
	15	550 316	NEBM-T1G8-E-15-N-S1G15
	X length <sup>1)</sup>	550 317	NEBM-T1G8-E- -N-S1G15
	For EMMS-AS-70/100/140		
	5	550 318	NEBM-M12W8-E-5-N-S1G15
	10	550 319	NEBM-M12W8-E-10-N-S1G15
	15	550 320	NEBM-M12W8-E-15-N-S1G15
	X length <sup>1)</sup>	550 321	NEBM-M12W8-E- -N-S1G15

1) Max. 25 m