

Square profile cylinders DNC - Inch Series



- Piston \varnothing 1-1/4" to 5"
- Standard strokes up to 20"
- Variable strokes up to 80"
- Double-acting
- Numerous variants
- Repairable

Product range overview														
Function	Design	Piston \varnothing [in]	Standard Stroke [in]	Available Stroke [in]	Force [lbf]	Variants								
						P	PPV	A	S2	K2	K3	K8	S6	R3
Double-acting	DNC	1-1/4, 1-5/8, 2, 2-1/2, 3, 4, 5	1 ... 20	0.4 ... 80.0	109 ... 1,655	■	■	■	■	■	■	■	■	■

Variants							
P	Flexible cushioning rings at both ends	A	Magnet for position sensing	K2	Extended male piston rod thread	K8	Extended piston rod
PPV	Adjustable air cushioning at both ends	S2	Through piston rod	K3	Female piston rod thread	S6	Heat resistant seals up to 302 °F
						R3	High corrosion protection

Square profile cylinders DNC - Inch Series

Product range overview

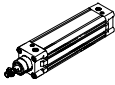
Function	Design	Type	Piston Ø [in]	Standard strokes [in]	Variable strokes [in]	Magnet for position sensing A	Through piston rod S2	Extended male thread K2	Female thread K3	Extended piston rod K8	Heat-resistant up to 302 °F S6	High corrosion protection R3
Double-acting		DNC	1-1/4, 1-5/8, 2, 2-1/2, 3, 4, 5	1, 2, 3, 4, 5, 6, 8, 10, 12, 16, 20	0.4 ... 80	■	■	■	■	■	■	■

Square profile cylinders DNC - Inch Series

Accessories overview

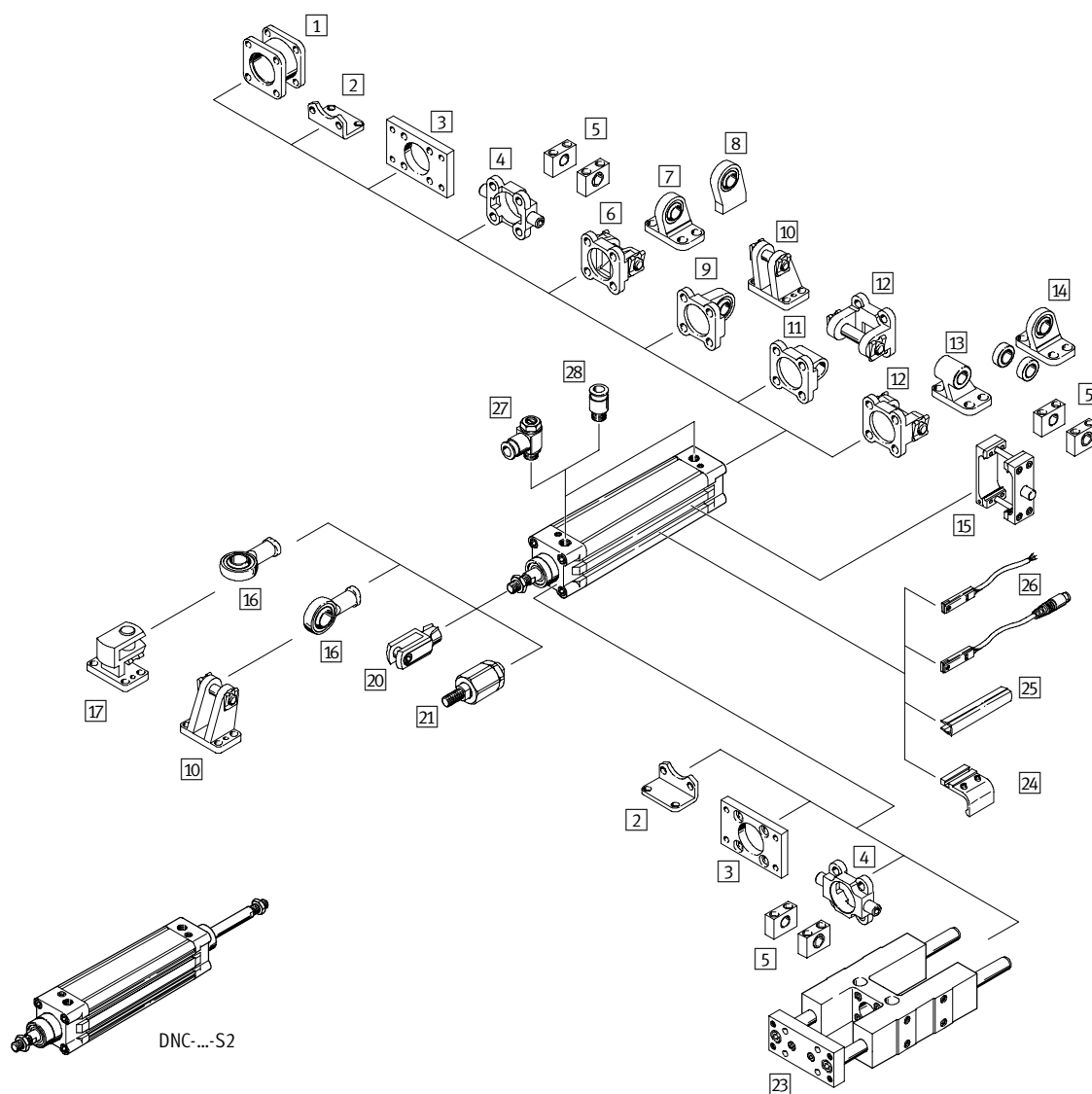

Mounting attachments and accessories			
	Description	DNC	
1	Adapter kit DPNC	For connecting two cylinders with identical piston \varnothing to form a multi-position cylinder	■ ¹⁾
2	Foot mounting HNC	For bearing and end cap	■
3	Flange mounting FNC	For bearing or end cap	■

Square profile cylinders DNC - Inch Series

Accessories overview

Mounting attachments and accessories		
	Description	DNC
4	Trunnion flange ZNCF	For bearing or end cap ■
5	Trunnion support LNZG	– ■
6	Swivel flange SNC	For end cap ■ ¹⁾
7	Clevis foot LSNG	With spherical bearing ■ ¹⁾
8	Clevis foot LSNSG	Weld-on, with spherical bearing ■ ¹⁾
9	Swivel flange SNCS	With spherical bearing for end caps ■ ¹⁾
10	Clevis foot LBG	– ■ ¹⁾
11	Swivel flange SNCL	For end cap ■ ¹⁾
12	Swivel flange SNCB/SNCB-...-R3	For end cap ■ ¹⁾
13	Clevis foot LNG	– ■ ¹⁾
14	Clevis foot LSN	With spherical bearing ■ ¹⁾
15	Trunnion mounting kit ZNCM	For mounting anywhere along the cylinder profile barrel ■
16	Rod eye SGS	With spherical bearing ■
17	Clevis foot, lateral LQG	– ■
20	Rod clevis SG	Permits a swivelling movement of the cylinder in one plane ■
21	Self-aligning rod coupler FK	For compensating radial and angular deviations ■
23	Guide unit FENG	For protecting standard cylinders from torsion at high torque loads ■
24	Sensor mounting kit SMB-8-FENG	For proximity sensor SMT-8 when attaching to cylinders in combination with guide unit FENG ■
25	Slot cover ABP-5-S	For protecting the sensor cable and keeping dirt out of the sensor slots ■
26	Proximity sensor SME/SMT-8	Can be integrated in the cylinder profile barrel from above ■
27	One-way flow control valve GRLA	For speed regulation ■
28	Push-in fitting QS	For connecting compressed air tubing with standard O.D. ■

1) Not with variant S2

Square profile cylinders DNC - Inch Series

Technical data

Double-acting

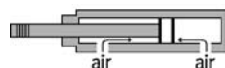

- \varnothing - Diameter
1-1/4 ... 5 in
- | - Stroke length
0.4 ... 80 in

Variants:

- Through piston rod (S2)
- Extended male thread (K2)
- Female thread (K3)
- Extended piston rod (K8)
- Heat resistant up to 302 °F (S6)
- High corrosion protection (R3)



General technical data								
Piston \varnothing	[in]	1-1/4	1-5/8	2	2-1/2	3	4	5
Stroke [in]		0.4 ... 80						
Pneumatic connection		1/8" NPT	1/4" NPT	1/4" NPT	3/8" NPT	3/8" NPT	1/2" NPT	1/2" NPT
Piston rod thread	Basic version	3/8-24 UNF	1/2-20 UNF	5/8-18 UNF	5/8-18 UNF	3/4-16 UNF	3/4-16 UNF	1-12 UNF
	K3	1/4-28 UNF	5/16-24 UNF	3/8-24 UNF	3/8-24 UNF	1/1-20 UNF	1/2-20 UNF	5/8-18 UNF
Constructional design		Piston						
		Piston rod						
		Cylinder barrel						
Cushioning (P)		Flexible cushioning rings at both ends						
Cushioning (PPV)		Adjustable air cushioning at both ends						
Cushioning length (PPV)	[in]	0.8	0.8	0.9	0.9	1.3	1.3	1.7
Magnet for position sensing ¹⁾		Optional						

1) Position sensing via magnetic proximity sensor (ordered separately, see accessories).

Operating conditions								
Piston \varnothing	[in]	1-1/4	1-5/8	2	2-1/2	3	4	5
Operating medium		Filtered compressed air, lubricated or unlubricated						
Operating pressure	[psi]	8.7 ... 174						8.7 ... 174

Square profile cylinders DNC - Inch Series

Technical data

FESTO

Ambient conditions			
Variant	Basic version	R3	S6
Ambient temperature ¹⁾ [°F]	-4 ... +176	-4 ... +176	-4 ... +302
Corrosion resistance class CRC ²⁾	2	3	2

- Note operating range of proximity sensors.
- Corrosion resistance class 2 according to Festo standard 940 070
Components with moderate corrosion resistance for use in normal industrial environments subjected to contact with coolants or lubricating agents.
Corrosion resistance class 3 according to Festo standard 940 070
Components requiring higher corrosion resistance for use in industrial environments subjected to contact with solvents and cleaning agents.

Forces [lbf] and impact energy [ft-lbf]							
Piston Ø	1-1/4	1-5/8	2	2-1/2	3	4	5
Theoretical force at 90 psi, extending	108.6	169.5	264.8	420.4	678.0	1059.3	1655.3
S2	93.3	142.3	222.6	378.1	611.7	993.2	1546.9
Theoretical force at 90 psi, retracting	93.3	142.3	222.6	378.1	611.7	993.2	1546.9
S2	93.3	142.3	222.6	378.1	611.7	993.2	1546.9
Max. impact energy at the end positions	0.07	0.15	0.15	0.37	0.66	0.89	3.69
Moving load at 0 inch stroke [m_{piston}]	5.7	10.8	19.0	23.4	39.9	54.8	99.1
Additional load per 1 inch stroke [m_{piston}]	0.8	1.4	2.2	2.2	3.4	3.4	5.6
S2- Moving load at 0 inch stroke [m_{piston}]	6.0	11.6	19.8	25.1	42.3	58.6	103.2
S2- Additional load per 1 inch stroke [m_{piston}]	1.6	2.9	4.5	4.5	6.8	6.8	11.3

Permissible impact velocity:
$$v_{\text{perm.}} = \sqrt{\frac{2 \times 32.2 E_{\text{perm.}}}{m_{\text{piston}} + m_{\text{load}}}}$$

Maximum permissible load:
$$m_{\text{load}} = \frac{2 \times 32.2 E_{\text{perm.}}}{v^2} - m_{\text{piston}}$$

Note

This data represents the maximum values that can be achieved. Values fluctuate in practice relative to the size of the effective load. Allowance

must also be made for the limits of the cushioning capacity of the drive and the permissible impact energy.

Note: m_{piston} equals mass of cylinder moving parts. m_{load} equals mass of applied external load.

Square profile cylinders DNC - Inch Series

Technical data

Lateral force F_Q as a function of stroke length l in the basic version

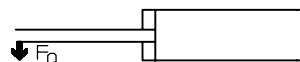
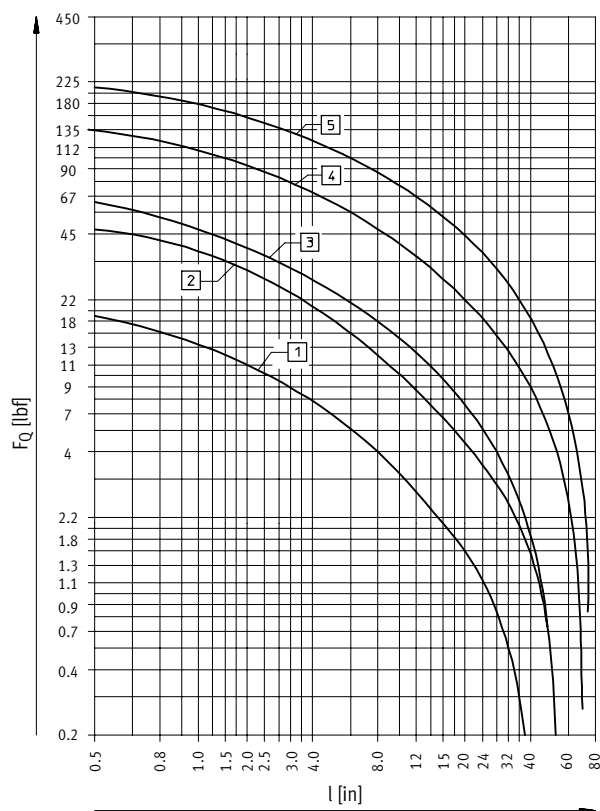

- 1) $\varnothing 1\text{-}1/4$
- 2) $\varnothing 1\text{-}5/8$
- 3) $\varnothing 2, 2\text{-}1/2$
- 4) $\varnothing 3, 4$
- 5) $\varnothing 5$

Weights [oz]							
Piston \varnothing	1-1/4	1-5/8	2	2-1/2	3	4	5
Basic version							
Product weight at 0 inch stroke	18.2	28.2	44.4	60.3	98.4	164.1	238.8
Additional weight per 1 inch stroke	2.7	4.0	5.7	6.5	9.5	10.3	15.1
Variant S2 – Through piston rod							
Product weight at 0 inch stroke	20.3	31.6	49.0	67.6	109.8	186.8	265.6
Additional weight per 1 inch stroke	3.5	5.5	8.0	8.8	12.9	13.7	20.7

Square profile cylinders DNC - Inch Series

Technical data

FESTO

Materials

Sectional view

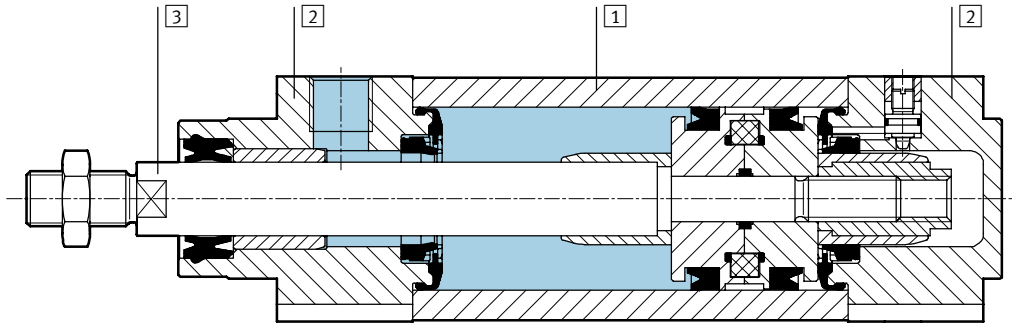

Variant	Basic version	R3 – High corrosion protection
1 Cylinder barrel	Wrought aluminum alloy, smooth-anodized	Wrought aluminum alloy, smooth-anodized
2 Bearing and end cap	Die-cast aluminum	Die-cast aluminum
3 Piston rod	High-alloy steel	High-alloy stainless steel
– Seals	Polyurethane, nitrile rubber	Polyurethane, nitrile rubber

Variant	S6 – Heat resistant seals up to 302 °F
1 Cylinder barrel	Wrought aluminum alloy, smooth-anodized
2 Bearing and end cap	Die-cast aluminum
3 Piston rod	High-alloy steel
– Seals	Fluorocarbon rubber

Square profile cylinders DNC - Inch Series

Technical data

Dimensions – Basic cylinders

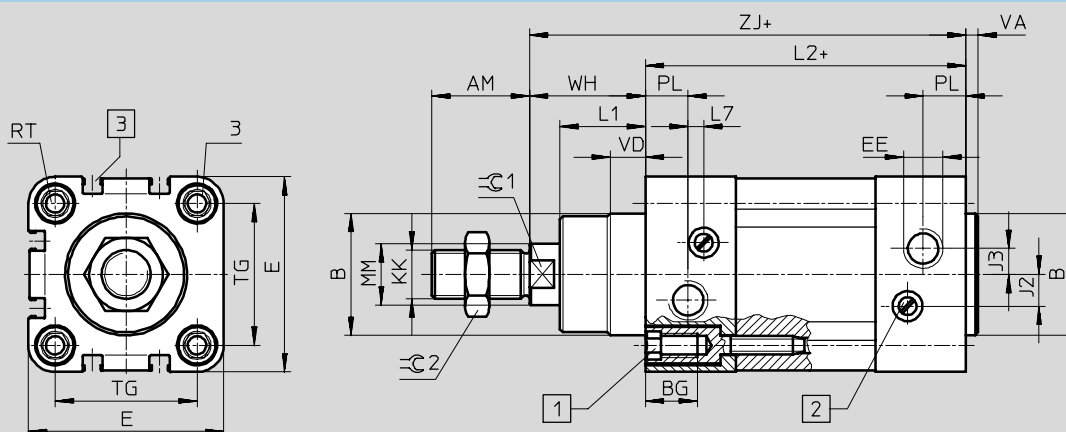

- 1 Socket head screw with female thread for mounting attachments
 - 2 Regulating screw for adjustable end-position cushioning
 - 3 Sensor slot for proximity sensor SME/SMT-8
- + = plus stroke length

∅	AM	B	BG	E	EE	J2	J3	KK	L1	L2
[in]		∅								
1-1/4	0.9	1.2	0.6	1.8	1/8" NPT	0.2	0.2	3/8-24 UNF	0.7	3.7
1-5/8	0.9	1.4	0.6	2.1	1/4" NPT	0.3	0.2	1/2-20 UNF	0.8	4.1
2	1.3	1.6	0.7	2.5	1/4" NPT	0.4	0.3	5/8-18 UNF	1.1	4.2
2-1/2	1.3	1.8	0.7	3.0	3/8" NPT	0.5	0.4	5/8-18 UNF	1.1	4.8
3	1.6	1.8	0.7	3.7	3/8" NPT	0.5	0.3	3/4-16 UNF	1.4	5.0
4	1.6	2.2	0.7	4.3	1/2" NPT	0.5	0.4	3/4-16 UNF	1.5	5.4
5	2.1	2.4	0.9	5.3	1/2" NPT	0.5	0.3	1-12 UNF	1.8	6.3

∅	L7	MM	PL	RT	TG	VA	VD	WH	ZJ	⌀C1	⌀C2	3
[in]		∅								[mm]	[mm]	[mm]
1-1/4	0.1	0.5	0.6	M6	1.3	0.2	0.4	1.0	4.7	10	16	HEX 6
1-5/8	0.1	0.6	0.6	M6	1.5	0.2	0.4	1.2	5.3	13	18	HEX 6
2	0.2	0.8	0.6	M8	1.8	0.2	0.5	1.5	5.6	17	24	HEX 8
2-1/2	0.3	0.8	0.7	M8	2.2	0.2	0.6	1.5	6.2	17	24	HEX 8
3	0.4	1.0	0.6	M10	2.8	0.2	0.6	1.8	6.9	22	30	HEX 6
4	0.3	1.0	0.7	M10	3.5	0.2	0.8	2.0	7.4	22	30	HEX 6
5	0.6	1.3	0.7	M12	4.3	0.2	0.8	2.6	8.9	27	36	HEX 8

Dimensions are in inches, unless otherwise noted.

Square profile cylinders DNC - Inch Series

Technical data



Dimensions – Variants

S2 – Through piston rod

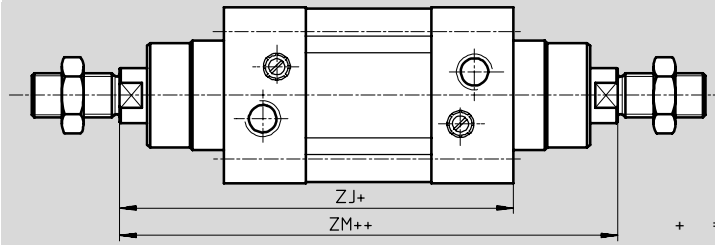

Note

The thread designs on both piston rod ends are identical.

+ = plus stroke length
++ = plus 2 stroke lengths

\varnothing	ZJ	ZM
[in]		
1-1/4	4.7	5.8
1-5/8	5.3	6.6
2	5.6	7.2
2-1/2	6.2	7.8
3	6.9	8.7
4	7.4	9.4
5	8.9	11.5

Dimensions are in inches, unless otherwise noted.

Square profile cylinders DNC - Inch Series

Technical data

Dimensions – Variants

K2 – Extended male piston rod thread

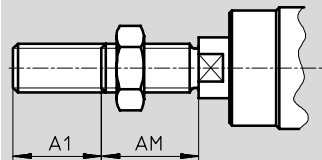

K3 – Female piston rod thread

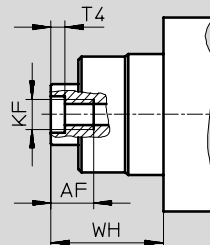

K8 – Extended piston rod

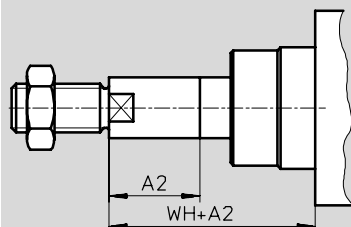

Note

In combination with variant S2, the piston rod is extended only on one side.

∅	A1	A2	AF	AM	KF	T4	WH
[in]	max.	max.					
1-1/4	1.4	19.7	0.5	0.9	1/4-28 UNF	0.10	1.0
1-5/8	1.4	19.7	0.5	0.9	5/16-24 UNF	0.13	1.2
2	2.8	19.7	0.6	1.3	3/8-24 UNF	0.19	1.5
2-1/2	2.8	19.7	0.6	1.3	3/8-24 UNF	0.19	1.5
3	2.8	19.7	0.8	1.6	1/2-20 UNF	0.24	1.8
4	2.8	19.7	0.8	1.6	1/2-20 UNF	0.24	2.0
5	2.8	19.7	1.3	2.1	5/8-18 UNF	0.31	2.6

1) The special threads are only available as male threads. The scope of delivery does not include a hex nut for the piston rod thread.

Dimensions are in inches, unless otherwise noted.

Square profile cylinders DNC - Inch Series

Ordering Data

FESTO

M Mandatory data				O Options						
Function	Piston ∅	Stroke	Cushioning	Magnet for position sensing	Through piston rod	Extended male thread	Female thread	Extended piston rod	Heat resistant seals	High corrosion protection
DNC	1 1/4 1 5/8 2 2 1/2 3 4 5	0.4 ... 80	P PPV	A	S2	...K2	K3	...K8	S6	R3
DNC	3	20	PPV	A				1.5K8	S6	

Ordering table											
Size	1 1/4	1 5/8	2	2 1/2	3	4	5	Conditions	Code	Enter code	
M Function	Standard cylinder, double-acting								DNC	DNC	
Piston ∅ [in]	1 1/4	1 5/8	2	2 1/2	3	4	5		-...		
Stroke [in]	0.4 ... 80.0								-...		
Cushioning	Flexible cushioning rings at both ends								-P		
	Adjustable air cushioning at both ends								-PPV		
O Magnet for position sensing	For use with magnetic proximity sensor							1	-A		
Type of piston rod	Through piston rod							2	-S2		
Extended male thread [in]	Piston rod with extended male thread							3	-...K2		
	0.04 ... 1.4			0.04 ... 2.8							
Female thread	Female piston rod thread								-K3		
	1/4-28 UNF	5/16-24 UNF	3/8-24 UNF	3/8-24 UNF	1/2-20 UNF	1/2-20 UNF	5/8-18 UNF				
Extended piston rod	Extended piston rod								-...K8		
Heat-resistant	Heat-resistant seals for temperatures up to 302 °F								-S6		
High corrosion protection	All external cylinder surfaces comply with corrosion resistance class 3 to Festo standard 940 070. The piston rod is made from corrosion and acid resistant steel.								-R3		

1 Reliable position sensing requires a minimum stroke of 0.4 inch.

3 Not with K3.

2 In combination with K2: thread extension on both ends.
 In combination with K3: female thread on both ends.
 In combination with K8: piston rod extended at bearing cap end only.

Transfer order code

DNC - - - - - - - - - - - -

Square profile cylinders DNC - Inch Series

Accessories

Adapter kit DPNC

Material:

Flange: Wrought aluminum alloy

Threaded studs, hex nuts: Galvanized steel

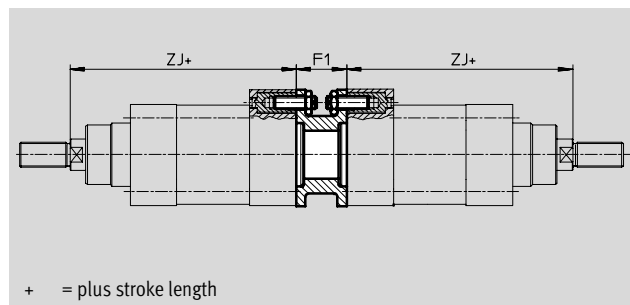
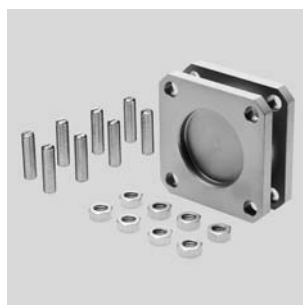

Note

Do not exceed the maximum overall stroke length listed when combining cylinders and the adapter kit.

Dimensions and ordering data						
For \varnothing	F1	ZJ	Max. overall stroke length	Weight	Part No.	Type
[in]			[in]	[oz]		
1-1/4	1.1	4.7	39.4	3.0	174418	DPNC-32
1-5/8	1.1	7.4	39.4	4.1	174419	DPNC-40
2	1.3	8.3	39.4	7.4	174420	DPNC-50
2-1/2	1.1	9.2	39.4	12.7	174421	DPNC-63
3	1.5	10.6	39.4	21.9	174422	DPNC-80
4	1.5	11.3	39.4	42.0	174423	DPNC-100
5	1.9	13.8	39.4	56.4	174424	DPNC-125

Connecting two cylinders with identical piston \varnothing as a 3 or 4-position cylinder

A 3 or 4-position cylinder consists of two separate cylinders whose piston rods advance in opposing directions.

This means that depending upon actuation and stroke pattern, this type of cylinder can assume up to four

positions. In each case the cylinder is driven precisely against a stop. Note that when one end of the piston rod is

fixed, the cylinder barrel executes the movement. The cylinder must be connected with flexible line connections.

To achieve 3 positions

Two cylinders with identical stroke length must be connected together.

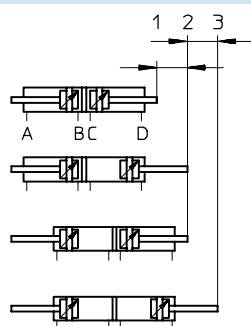

To achieve 4 positions

Two cylinders with different stroke lengths must be connected together.

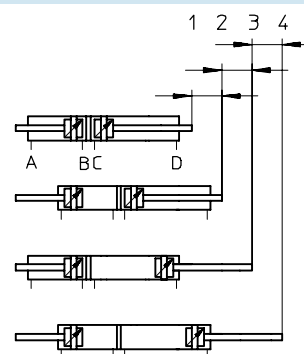

Dimensions are in inches, unless otherwise noted.

Square profile cylinders DNC - Inch Series

Accessories

FESTO

Foot mounting HNC

Material:

HNC: Galvanized steel

Free of copper, PTFE and silicone

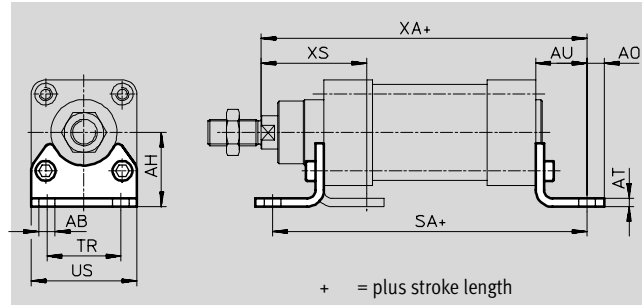

Dimensions										
For \varnothing	AB \varnothing	AH	AO	AT	AU	SA	TR	US	XA	XS
[in]										
1-1/4	0.3	1.3	0.26	0.2	0.9	5.6	1.3	1.8	5.7	1.8
1-5/8	0.4	1.4	0.35	0.2	1.1	6.3	1.4	2.1	6.4	2.1
2	0.4	1.8	0.37	0.2	1.3	6.7	1.8	2.5	6.9	2.4
2-1/2	0.4	2.0	0.49	0.2	1.3	7.3	2.0	3.0	7.5	2.5
3	0.5	2.5	0.59	0.2	1.6	8.3	2.5	3.7	8.5	3.2
4	0.6	2.8	0.69	0.2	1.6	8.7	3.0	4.3	9.1	3.4
5	0.6	3.5	0.87	0.2	1.8	9.8	3.5	5.2	10.6	4.0

Ordering data				
For \varnothing	Basic version			
	CRC ¹⁾	Weight [oz]	Part No.	Type
[in]				
1-1/4	2	4.8	174369	HNC-32
1-5/8	2	6.3	174370	HNC-40
2	2	11.5	174371	HNC-50
2-1/2	2	14.3	174372	HNC-63
3	2	28.9	174373	HNC-80
4	2	35.3	174374	HNC-100
5	2	64.9	174375	HNC-125

1) Corrosion resistance class 2 according to Festo standard 940 070
Components with moderate corrosion resistance for use in normal industrial environments subjected to contact with coolants or lubricating agents.

Dimensions are in inches, unless otherwise noted.

Square profile cylinders DNC - Inch Series

Accessories

Flange mounting FNC

Material:

FNC: Galvanized steel

Free of copper, PTFE and silicone

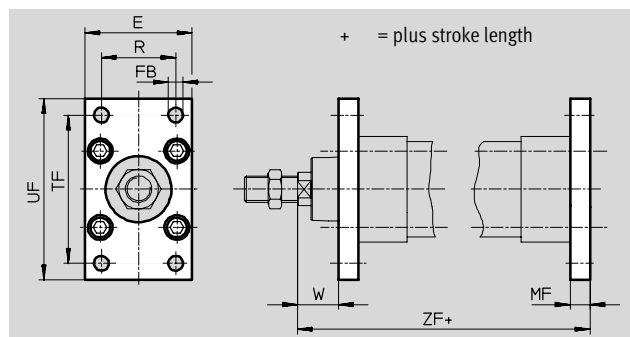

Dimensions								
For \varnothing	E	FB \varnothing	MF	R	TF	UF	W	ZF
[in]								
1-1/4	1.8	0.3	0.4	1.3	2.5	3.1	0.6	5.1
1-5/8	2.1	0.4	0.4	1.4	2.8	3.5	0.8	5.7
2	2.6	0.4	0.5	1.8	3.5	4.3	1.0	6.1
2-1/2	3.0	0.4	0.5	2.0	3.9	4.7	1.0	6.7
3	3.7	0.5	0.6	2.5	5.0	5.9	1.2	7.5
4	4.3	0.6	0.6	3.0	5.9	6.9	1.4	8.1
5	5.2	0.6	0.8	3.5	7.1	8.3	1.8	9.6

Ordering data				
For \varnothing	Basic version			
	CRC ¹⁾	Weight [oz]	Part No.	Type
[in]				
1-1/4	2	8.5	174376	FNC-32
1-5/8	2	9.9	174377	FNC-40
2	2	18.3	174378	FNC-50
2-1/2	2	24.3	174379	FNC-63
3	2	58.2	174380	FNC-80
4	2	84.7	174381	FNC-100
5	2	132.3	174382	FNC-125

1) Corrosion resistance class 2 according to Festo standard 940 070
Components with moderate corrosion resistance for use in normal industrial environments subjected to contact with coolants or lubricating agents.

Dimensions are in inches, unless otherwise noted.

Square profile cylinders DNC - Inch Series

Accessories

FESTO

Trunnion flange ZNCF

Material:

ZNCF: Special steel casting

stainless steel casting

Free of copper, PTFE and silicone

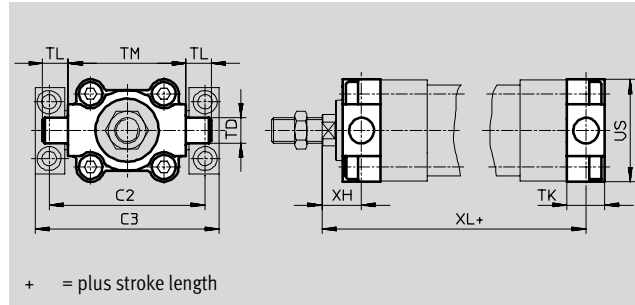

Dimensions									
For \varnothing	C2	C3	TD \varnothing	TK	TL	TM	US	XH	XL
[in]									
1-1/4	2.8	3.4	0.5	0.6	0.5	2.0	1.8	0.7	5.0
1-5/8	3.4	4.1	0.6	0.8	0.6	2.5	2.1	0.8	5.7
2	3.9	4.6	0.6	0.9	0.6	3.0	2.5	1.0	6.1
2-1/2	4.6	5.4	0.8	0.9	0.8	3.5	3.0	1.0	6.7
3	5.4	6.1	0.8	1.1	0.8	4.3	3.7	1.3	7.4
4	6.5	7.4	1.0	1.5	1.0	5.2	4.3	1.3	8.2
5	7.6	8.5	1.0	2.0	1.0	6.3	5.2	1.6	9.8

Ordering data				
For \varnothing	Basic version			
	CRC ¹⁾	Weight [g]	Part No.	Type
[in]				
1-1/4	2	4.6	174411	ZNCF-32
1-5/8	2	8.5	174412	ZNCF-40
2	2	13.8	174413	ZNCF-50
2-1/2	2	21.2	174414	ZNCF-63
3	2	40.6	174415	ZNCF-80
4	2	71.6	174416	ZNCF-100
5	2	123.1	174417	ZNCF-125

1) Corrosion resistance class 2 according to Festo standard 940 070

Components with moderate corrosion resistance for use in normal industrial environments subjected to contact with coolants or lubricating agents.

Dimensions are in inches, unless otherwise noted.

Square profile cylinders DNC - Inch Series

Accessories



Trunnion mounting kit ZNCM for basic cylinder DNC

The mounting kit can be attached at any position along the profile barrel of a cylinder.

Material:
Tempered steel

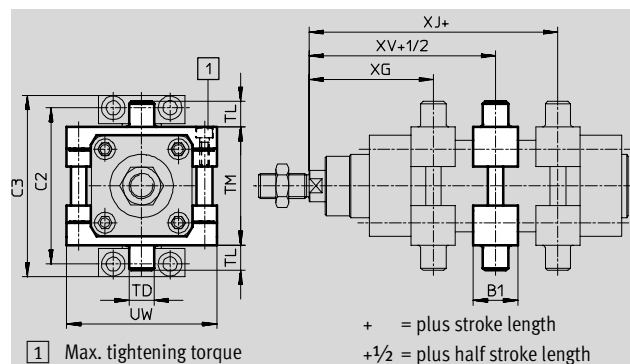

Dimensions								
For \varnothing	B1	C2	C3	TD	TL	TM	UW	XG
[in]				\varnothing				
1-1/4	1.2	2.8	3.4	0.5	0.5	2.0	2.6	2.6
1-5/8	1.3	3.4	4.1	0.6	0.6	2.5	3.0	3.0
2	1.3	3.9	4.6	0.6	0.6	3.0	3.7	3.3
2-1/2	1.6	4.6	5.4	0.8	0.8	3.5	4.1	3.7
3	1.7	5.4	6.1	0.8	0.8	4.3	5.1	4.1
4	1.9	6.5	7.4	1.0	1.0	5.2	5.7	4.5
5	2.0	7.6	8.5	1.0	1.0	6.3	6.9	5.3

Ordering data							
For \varnothing	XJ	XV	Max. tightening torque	CRC ¹⁾	Weight	Part No.	Type
[in]			[lbf-in]		[oz]		
1-1/4	3.15	2.9	35.4	2	7.4	163525	ZNCM-32
1-5/8	3.52	3.25	70.8	2	13.6	163526	ZNCM-40
2	3.80	3.5	70.8	2	21.0	163527	ZNCM-50
2-1/2	4.01	3.84	159.3	2	31.4	163528	ZNCM-63
3	4.57	4.3	247.8	2	51.1	163529	ZNCM-80
4	4.97	4.7	247.8	2	72.1	163530	ZNCM-100
5	6.11	5.7	354.0	2	103.7	163531	ZNCM-125

1) Corrosion resistance class 2 according to Festo standard 940 070
Components with moderate corrosion resistance for use in normal industrial environments subjected to contact with coolants or lubricating agents.

Dimensions are in inches, unless otherwise noted.

Square profile cylinders DNC - Inch Series

Accessories

FESTO

Trunnion support LNZG

Material:

Galvanized steel

Free of copper, PTFE and silicone

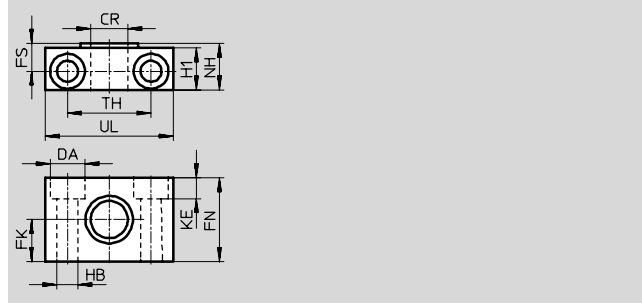
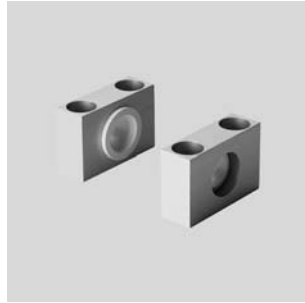

Dimensions and ordering data															
For \varnothing	CR	DA	FK	FN	FS	H1	HB	KE	NH	TH	UL	CRC ¹⁾	Weight	Part No.	Type
[in]	\varnothing	\varnothing	\varnothing				\varnothing						[oz]		
1-1/4	0.5	0.4	0.6	1.2	0.4	0.6	0.3	0.3	0.7	1.3	1.8	2	4.4	32959	LNZG-32
1-5/8, 2	0.6	0.6	0.7	1.4	0.5	0.7	0.4	0.4	0.8	1.4	2.2	2	14.1	32960	LNZG-40/50
2-1/2, 3	0.8	0.7	0.8	1.6	0.5	0.8	0.4	0.4	0.9	1.7	2.6	2	16.9	32961	LNZG-63/80
4, 5	1.0	0.8	1.0	2.0	0.6	1.0	0.6	0.5	1.1	2.0	3.0	2	33.9	32962	LNZG-100/125

1) Corrosion resistance class 2 according to Festo standard 940 070
Components with moderate corrosion resistance for use in normal industrial environments subjected to contact with coolants or lubricating agents.

Dimensions are in inches, unless otherwise noted.

Square profile cylinders DNC - Inch Series

Accessories

Swivel flange SNC

Material:

Wrought aluminum alloy

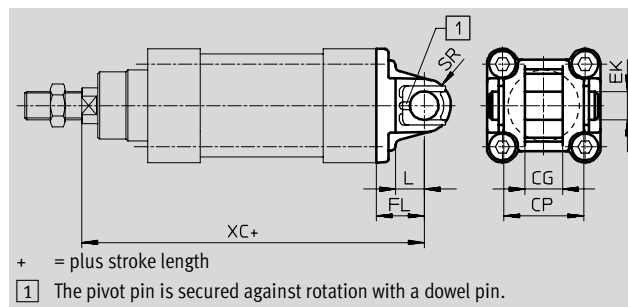

Dimensions and ordering data											
For \varnothing	CG	CP	EK \varnothing	FL	L	SR	XC	CRC ¹⁾	Weight	Part No.	Type
[in]									[oz]		
1-1/4	0.6	1.3	0.4	0.9	0.5	0.4	5.6	2	3.2	174383	SNC-32
1-5/8	0.6	1.6	0.5	1.0	0.6	0.5	6.3	2	4.2	174384	SNC-40
2	0.8	1.8	0.6	1.1	0.6	0.6	6.7	2	8.5	174385	SNC-50
2-1/2	0.8	2.0	0.6	1.3	0.8	0.6	7.5	2	11.3	174386	SNC-63
3	1.0	2.6	0.8	1.4	0.9	0.8	8.3	2	22.0	174387	SNC-80
4	1.0	3.0	0.8	1.6	1.1	0.8	9.1	2	29.3	174388	SNC-100
5	1.5	3.8	1.2	2.0	1.2	1.2	10.8	2	63.0	174389	SNC-125

1) Corrosion resistance class 2 according to Festo standard 940 070

Components with moderate corrosion resistance for use in normal industrial environments subjected to contact with coolants or lubricating agents.

Dimensions are in inches, unless otherwise noted.

Square profile cylinders DNC - Inch Series

Accessories

FESTO

Swivel flange

SNCB/SNCB-...-R3

Material:

SNCB: Wrought aluminum alloy

SNCB-...-R3: Wrought aluminum alloy,

silver protective coating, high

corrosion protection

Free of copper, PTFE and silicone

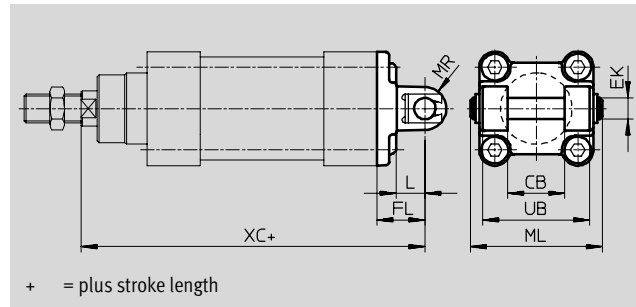

Dimensions								
For \varnothing	CB	EK \varnothing	FL	L	ML	MR	UB	XC
[in]								
1-1/4	1.0	0.4	0.9	0.5	2.2	0.4	1.8	5.6
1-5/8	1.1	0.5	1.0	0.6	2.5	0.5	2.0	6.3
2	1.3	0.5	1.1	0.6	2.8	0.5	2.4	6.7
2-1/2	1.6	0.6	1.3	0.8	3.3	0.6	2.8	7.5
3	2.0	0.6	1.4	0.9	4.1	0.6	3.5	8.3
4	2.4	0.8	1.6	1.1	5.0	0.8	4.3	9.1
5	2.8	1.0	2.0	1.2	5.8	1.0	5.1	10.8

Ordering data								
For \varnothing	Basic version				Variant R3 – High corrosion protection			
	CRC ¹⁾	Weight [oz]	Part No.	Type	CRC ¹⁾	Weight [oz]	Part No.	Type
[in]								
1-1/4	2	3.5	174390	SNCB-32	3	3.5	176944	SNCB-32-R3
1-5/8	2	5.3	174391	SNCB-40	3	5.3	176945	SNCB-40-R3
2	2	7.9	174392	SNCB-50	3	7.9	176946	SNCB-50-R3
2-1/2	2	12.9	174393	SNCB-63	3	12.9	176947	SNCB-63-R3
3	2	21.5	174394	SNCB-80	3	21.5	176948	SNCB-80-R3
4	2	32.6	174395	SNCB-100	3	32.6	176949	SNCB-100-R3
5	2	63.0	174396	SNCB-125	3	63.0	176950	SNCB-125-R3

1) Corrosion resistance class 2 according to Festo standard 940 070
Components with moderate corrosion resistance for use in normal industrial environments subjected to contact with coolants or lubricating agents.

Corrosion resistance class 3 according to Festo standard 940 070
Components requiring higher corrosion resistance for use in industrial environments subjected to contact with solvents and cleaning agents.

Dimensions are in inches, unless otherwise noted.

Square profile cylinders DNC - Inch Series

Accessories

Swivel flange SNCS

Material:
Wrought aluminum alloy

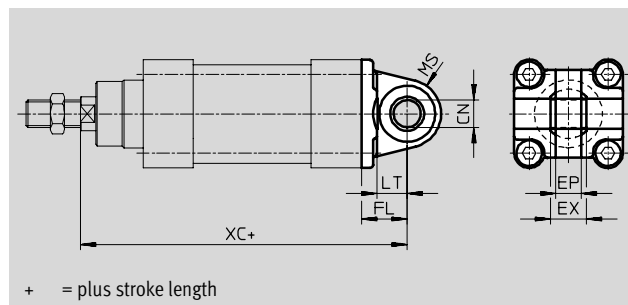
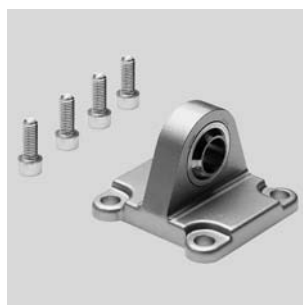

+ = plus stroke length

Dimensions and ordering data											
For Ø	CN	EP	EX	FL	LT	MS	XC	CRC ¹⁾	Weight	Part No.	Type
[in]	Ø								[oz]		
1-1/4	0.4	0.4	0.6	0.9	0.5	0.6	5.6	2	3.0	174397	SNCS-32
1-5/8	0.5	0.5	0.6	1.0	0.6	0.7	6.3	2	4.4	174398	SNCS-40
2	0.6	0.6	0.8	1.1	0.7	0.8	6.7	2	7.4	174399	SNCS-50
2-1/2	0.6	0.6	0.8	1.3	0.8	0.9	7.5	2	9.9	174400	SNCS-63
3	0.8	0.7	1.0	1.4	0.9	1.1	8.3	2	19.0	174401	SNCS-80
4	0.8	0.7	1.0	1.6	1.1	1.1	9.1	2	24.7	174402	SNCS-100
5	1.2	1.0	1.5	2.0	1.2	1.5	10.8	2	49.7	174403	SNCS-125

1) Corrosion resistance class 2 according to Festo standard 940 070
Components with moderate corrosion resistance for use in normal industrial environments subjected to contact with coolants or lubricating agents.

Swivel flange SNCL

Material:
Wrought aluminum alloy
Free of copper, PTFE and silicone

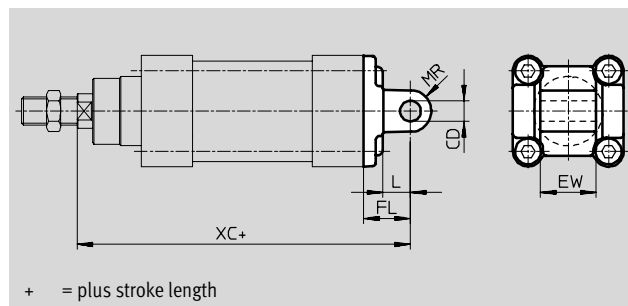
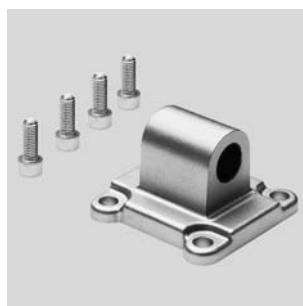

+ = plus stroke length

Dimensions and ordering data											
For Ø	CD	EW	FL	L	MR	XC	CRC ¹⁾	Weight	Part No.	Type	
[in]	Ø							[oz]			
1-1/4	0.4	1.0	0.9	0.5	0.4	5.6	2	2.6	174404	SNCL-32	
1-5/8	0.5	1.1	1.0	0.6	0.5	6.3	2	3.5	174405	SNCL-40	
2	0.5	1.3	1.1	0.6	0.5	6.7	2	5.6	174406	SNCL-50	
2-1/2	0.6	1.6	1.3	0.8	0.6	7.5	2	8.8	174407	SNCL-63	
3	0.6	2.0	1.4	0.9	0.6	8.3	2	14.3	174408	SNCL-80	
4	0.8	2.4	1.6	1.1	0.8	9.1	2	23.1	174409	SNCL-100	
5	1.0	2.8	2.0	1.2	1.0	10.8	2	43.9	174410	SNCL-125	



1) Corrosion resistance class 2 according to Festo standard 940 070
Components with moderate corrosion resistance for use in normal industrial environments subjected to contact with coolants or lubricating agents.

Dimensions are in inches, unless otherwise noted.

Square profile cylinders DNC - Inch Series

Accessories

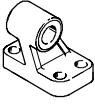
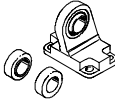
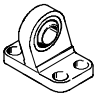

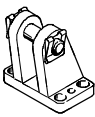
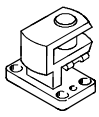
FESTO

Ordering data – Mounting attachments				Ordering data – Mounting attachments			
Designation	For Ø [in]	Part No.	Type	Designation	For Ø [in]	Part No.	Type
Clevis foot mounting LNG				Clevis foot mounting LSN			
	1-1/4	33890	LNG-32		1-1/4	5561	LSN-32
	1-5/8	33891	LNG-40		1-5/8	5562	LSN-40
	2	33892	LNG-50		2	5563	LSN-50
	2-1/2	33893	LNG-63		2-1/2	5564	LSN-63
	3	33894	LNG-80		3	5565	LSN-80
	4	33895	LNG-100		4	5566	LSN-100
5	33896	LNG-125	5	6987	LSN-125		
Clevis foot mounting LSNG				Weld-on clevis foot mounting LSNSG			
	1-1/4	31740	LSNG-32		1-1/4	31747	LSNSG-32
	1-5/8	31741	LSNG-40		1-5/8	31748	LSNSG-40
	2	31742	LSNG-50		2	31749	LSNSG-50
	2-1/2	31743	LSNG-63		2-1/2	31750	LSNSG-63
	3	31744	LSNG-80		3	31751	LSNSG-80
	4	31745	LSNG-100		4	31752	LSNSG-100
5	31746	LSNG-125	5	31753	LSNSG-125		
Clevis foot mounting LBG				Clevis foot, right-angled LQG			
	1-1/4	31761	LBG-32		1-1/4	31768	LQG-32
	1-5/8	31762	LBG-40		1-5/8	31769	LQG-40
	2	31763	LBG-50		2	31770	LQG-50
	2-1/2	31764	LBG-63		2-1/2	31771	LQG-63
	3	31765	LBG-80		3	31772	LQG-80
	4	31766	LBG-100		4	31773	LQG-100
5	31767	LBG-125	5	31774	LQG-125		

Square profile cylinders DNC - Inch Series

Accessories

FESTO

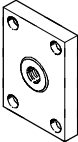
Ordering data – Piston rod attachments							
Designation	For Ø [in]	Part No.	Type	Designation	For Ø [in]	Part No.	Type
Rod eye SGS				Coupling piece KSZ			
	1-1/4	532696	SGS-3/8-24		1-1/4	36129	KSZ-3/8-24-UNF
	1-5/8	532697	SGS-1/2-20		1-5/8	36130	KSZ-1/2-20-UNF
	2	532698	SGS-5/8-18		2	36131	KSZ-5/8-18-UNF
	2-1/2				2-1/2		
	3	532699	SGS-3/4-16		3	36132	KSZ-3/4-16-UNF
	4				4		
	5	532700	SGS-1-12	5	–		
Rod clevis SG				Self-aligning rod coupler FK			
	1-1/4	546540	SG-UNF3/8-24-B		1-1/4	532705	FK-3/8-24
	1-5/8	546545	SG-UNF1/2-20-B		1-5/8	532706	FK-1/2-20
	2	546575	SG-UNF5/8-18-B		2	532707	FK-5/8-18
	2-1/2				2-1/2		
	3	546576	SG-UNF3/4-16-B		3	532708	FK-3/4-16
	4				4		
	5	–		5	532709	FK-1-12	

Square profile cylinders DNC - Inch Series

Accessories

FESTO

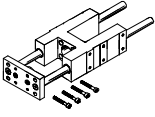

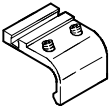
Ordering data – Guide units						
	For Ø [in]	Stroke [in]	with recirculating ball bearing guide		with plain bearing guide	
			Part No.	Type	Part No.	Type
	1-1/4	0.4 ... 20	151746	FENG-1 1/4"-...-KF	151740	FENG-1 1/4"-...-
	1-5/8	0.4 ... 20	151747	FENG-1 5/8"-...-KF	151741	FENG-1 5/8"-...-
	2	0.4 ... 20	151748	FENG-2"-...-KF	151742	FENG-2"-...-
	2-1/2	0.4 ... 20	151749	FENG-2 1/2"-...-KF	151743	FENG-2 1/2"-...-
	3	0.4 ... 20	151750	FENG-3"-...-KF	151744	FENG-3"-...-
	4	0.4 ... 20	151751	FENG-4"-...-KF	151745	FENG-4"-...-



Ordering data – Mounting kit for proximity sensors SME/SMT-8			
	For Ø [in]	Part No.	Type
	1-1/4	175705	SMB-8-FENG-32/40
	1-5/8		
	2	175706	SMB-8-FENG-50/63
	2-1/2		
	3	175707	SMB-8-FENG-80/100
	4		





Square profile cylinders DNC - Inch Series

Accessories

FESTO

Ordering data – Proximity sensor for slot type 8, magneto-resistive										
	Mounting	Switch out-put	Electrical connection			Cable length [ft]	Part No.	Type		
			Cable	M8 plug	M12 plug					
NO contact										
	Insertable from above	PNP	3-wire	–	–	8.2	525898	SMT-8F-PS-24V-K2.5-OE		
		NPN		–	–		525909	SMT-8F-NS-24V-K2.5-OE		
	–	–	2-wire	–	–	8.2	525908	SMT-8F-ZS-24V-K2.5-OE		
		PNP		–	3-pin		–	1.0	525899	SMT-8F-PS-24V-K0.3-M8D
		NPN		–					525910	SMT-8F-NS-24V-K0.3-M8D
PNP	–	–	3-pin	–	1.0	525900	SMT-8F-PS-24V-K0.3-M12			
–	–	–				–	–	1.0	175436	SMT-8-PS-K-LED-24-B
	Insertable from end, flush with the cylinder profile	PNP	3-wire	–	–	8.2	175436	SMT-8-PS-K-LED-24-B		
		–	–	3-pin	–	–	1.0	175484	SMT-8-PS-S-LED-24-B	
NC contact										
	Insertable from above	PNP	3-wire	–	–	24.6	525911	SMT-8F-PO-24V-K7.5-OE		

Ordering data – Proximity sensor for slot type 8, magnetic reed							
	Mounting	Electrical connection		Cable length [ft]	Part No.	Type	
		Cable	M8 plug				
NO contact							
	Insertable from above	3-wire		–	8.2	525895	SME-8F-DS-24V-K2.5-OE
		–		–		16.4	525897
	–	2-wire		–	8.2	525907	SME-8F-ZS-24V-K2.5-OE
		–	3-pin			–	1.0
	Insertable from end, flush with the cylinder profile	3-wire		–	8.2	150855	SME-8-K-LED-24
		–	3-pin			–	1.0
NC contact							
	Insertable from above	3-wire		–	24.6	525906	SME-8F-DO-24V-K7.5-OE

Ordering data – Plug sockets							
	Mounting	Switch output		Connection	Cable length [ft]	Part No.	Type
		PNP	NPN				
Straight plug socket							
	Union nut M8	■	■	3-pin	8.2	159420	SIM-M8-3GD-2.5-PU
		■	■		16.4	159421	SIM-M8-3GD-5-PU
	Union nut M12	■	■	3-pin	8.2	159428	SIM-M12-3GD-2.5-PU
		■	■		16.4	159429	SIM-M12-3GD-5-PU
Angled plug socket							
	Union nut M8	■	■	3-pin	8.2	159422	SIM-M8-3WD-2.5-PU
		■	■		16.4	159423	SIM-M8-3WD-5-PU
	Union nut M12	■	■	3-pin	8.2	159430	SIM-M12-3WD-2.5-PU
		■	■		16.4	159431	SIM-M12-3WD-5-PU

Ordering data – Slot cover for slot type 8			
	Mounting	Length [ft]	Part No. Type
	Insertable from above	2x 1.6	151680 ABP-5-S

Square profile cylinders DNC - Inch Series

Accessories

FESTO

Ordering data – One-way flow control valves				
	Connection		Part No.	Type
	Thread	For tubing O.D.		
	1/8" NPT	5/32"	165009	GRLA-1/8-NPT-QS-5/32-U
		3/16"	190941	GRLA-1/8-NPT-QS-3/16-U
		1/4"	165010	GRLA-1/8-NPT-QS-1/4-U
		5/16"	165013	GRLA-1/8-NPT-QS-5/16-U
	1/4" NPT	3/16"	190944	GRLA-1/4-NPT-QS-3/16-U
		1/4"	165011	GRLA-1/4-NPT-QS-1/4-U
		5/16"	165014	GRLA-1/4-NPT-QS-5/16-U
		3/8"	190947	GRLA-1/4-NPT-QS-3/8-U
	3/8" NPT	1/4"	165012	GRLA-3/8-NPT-QS-1/4-U
		5/16"	165015	GRLA-3/8-NPT-QS-5/16-U
		3/8"	190950	GRLA-3/8-NPT-QS-3/8-U
		1/2"	190951	GRLA-3/8-NPT-QS-1/2-U
	1/2" NPT	3/8"	190952	GRLA-1/2-NPT-QS-3/8-U
		1/2"	190953	GRLA-1/2-NPT-QS-1/2-U