



- Piston \varnothing 1/2" to 1-5/8"
- Strokes up to 157"
- Double-acting
- Patented magnetic-coupling design
- Leakproof operation

Double-acting rodless cylinders equipped with magnetic coupling between the internal piston and external yoke. Movement of the external yoke results when the internal piston is driven with air pressure in either direction. The magnetic force of the piston pulls the external yoke along the cylinder tube. As the piston moves, the working force is transferred to the yoke.

Because no piston rod extends, these cylinders require less space than traditional pneumatic cylinders. Operating devices and loads can be mounted directly to a flat mounting surface on the outer yoke. Intermediate and end positions of the piston can be detected by proximity sensors, using the magnetic field of the yoke. The cylinder area is hermetically sealed from the outer yoke to prevent leakage.

Product range overview						
Function	Type	Piston \varnothing [in]	Stroke [in]	Force [lbf]	Variants	
					P	PPV
Double-acting	DGO	1/2, 5/8, 3/4, 1, 1-1/4, 1-5/8	0.4 ... 157	13 ... 145	■	■

Variants

- P Flexible cushioning rings at both ends
- PPV Adjustable air cushioning at both ends

Rodless cylinders DGO - Inch Series

Accessories overview

FESTO

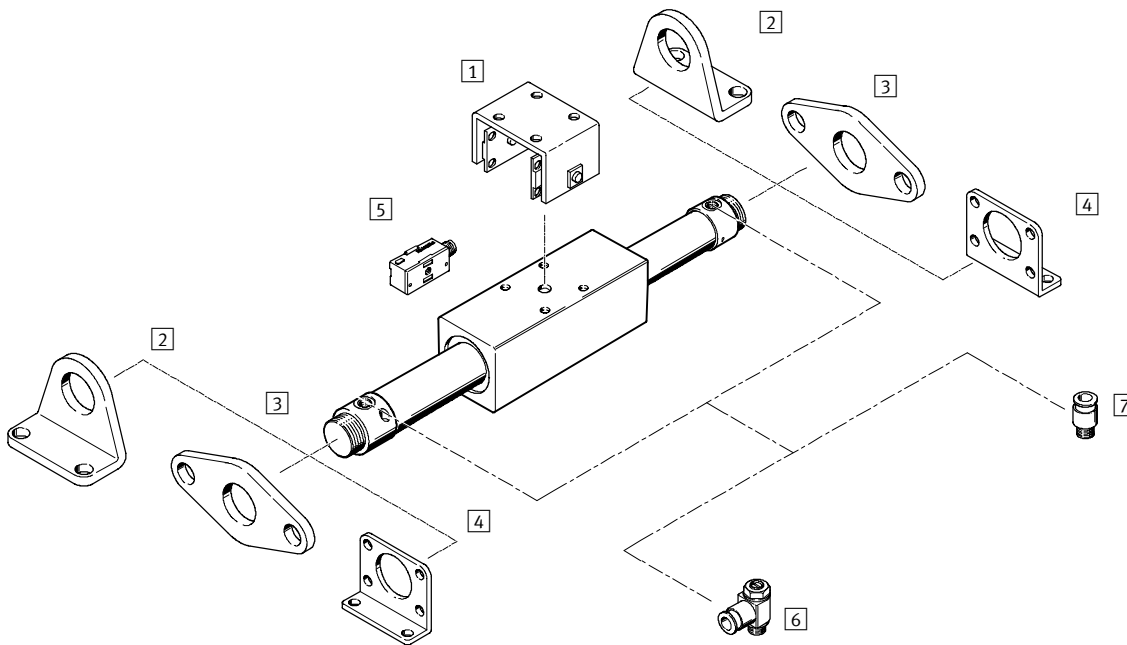

Mounting attachments and accessories	
	Description
1	Moment compensator FKG To compensate misalignments and eliminate tilting moments
2	Foot mounting HBN On end caps for piston \varnothing 1/2 ... 1 inch
3	Flange mounting FBN On end caps for piston \varnothing 1/2 ... 1 inch
4	Flange mounting FBN On end caps for piston \varnothing 1-1/4 ... 1-5/8 inch
5	Proximity sensors SMEO-/SMTO-/SMPO-1 For contactless position sensing, mountable externally via a mounting kit
6	One-way flow control valve GRLA To regulate speed
7	Push-in fitting QS For connecting compressed air tubing with standard external diameters

Rodless cylinders DGO - Inch Series

Technical data

Function

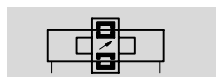

- Double-acting
- Magnetically coupled

∅ - Diameter
1/2 ... 1-5/8 inch

l - Stroke length
0.4 ... 157 inch



General technical data						
Piston ∅	1/2	5/8	3/4	1	1-1/4	1-5/8
Stroke [in]	0.4 ... 47	0.4 ... 98	0.4 ... 118	0.4 ... 137		0.4 ... 157
Pneumatic connection	10-32 UNF		1/8" NPT		1/4" NPT	
Operating medium	Filtered compressed air, lubricated or unlubricated, other media upon request.					
Design	Rodless (magnetically coupled)					
Cushioning	Flexible cushioning rings at both ends (P)		Adjustable air cushioning at both ends (PPV)			
Cushioning length [in]	-	0.55	0.67	0.75	0.79	0.91
Magnet for position sensing ¹⁾	Standard					

1) Position sensing via magnetic proximity sensor (ordered separately, see accessories).

Operating and environmental conditions						
Piston ∅	1/2	5/8	3/4	1	1-1/4	1-5/8
Operating pressure [psi]	29.4 ... 102.9	25.0 ... 102.9	23.5 ... 102.9	22.0 ... 102.9	20.6 ... 102.9	19.1 ... 102.9
Temperature range ¹⁾ [°F]	-4 ... +140					

1) Note operating range of proximity sensors

Forces [lbf]						
Piston ∅	1/2	5/8	3/4	1	1-1/4	1-5/8
Theoretical force at 90 psi	15.3	27.2	42.3	66.3	108.6	169.5
Breakaway force of the magnetic coupling	22.5	36.0	60.7	89.9	152.9	236.0

Weights [oz]						
Piston ∅	1/2	5/8	3/4	1	1-1/4	1-5/8
Product weight with 0 inch stroke	11.3	21.9	35.3	47.3	84.7	138.3
Additional weight per 1 inch stroke	0.18	0.27	0.36	0.43	0.54	0.72

Rodless cylinders DGO - Inch Series

Technical data

Materials

Sectional view

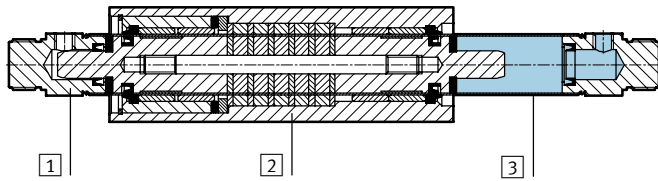

Linear drive unit

1	End cap	Anodized aluminum
2	Outer slide	Anodized aluminum
3	Cylinder barrel	High-alloy steel
-	Seals	Nitrile rubber, polyurethane

Permissible axial force F dependent on lever arm A

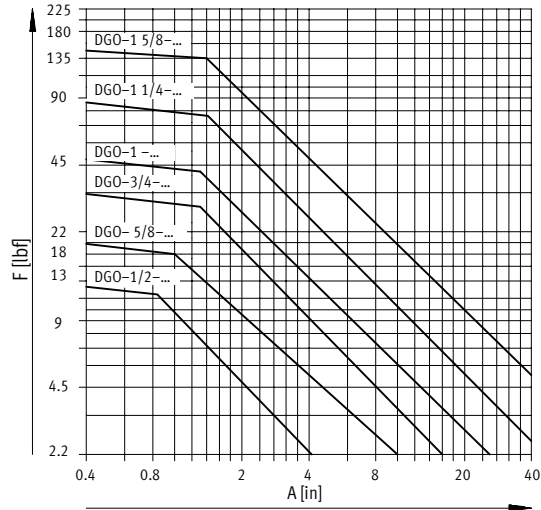
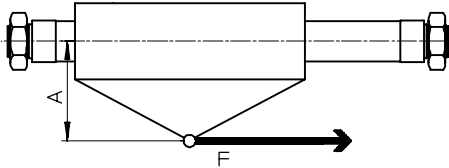

Permissible lateral force F_q dependent on stroke length L

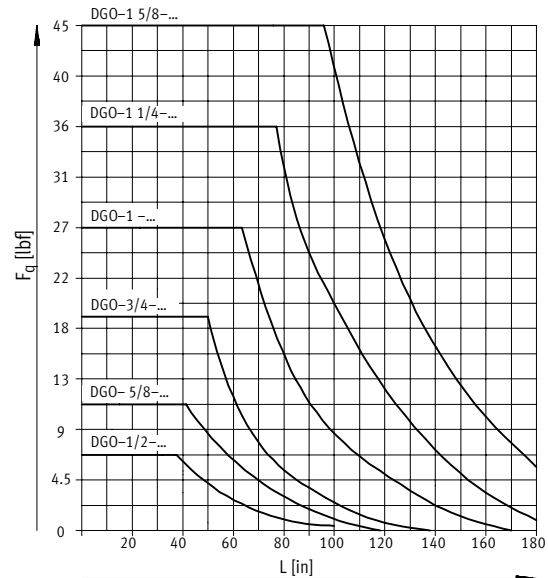
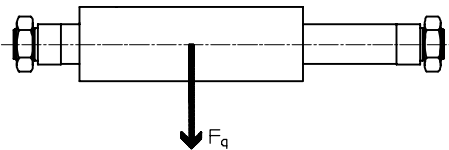

Rodless cylinders DGO - Inch Series

Technical data

Max. piston speed v dependent on the moving mass m

If the operating conditions are outside the permissible range, the moving mass must be externally cushioned using suitable equipment (shock absorbers or stops). This is done to avoid de-coupling the carriage from the piston.

Lubrication

The DGO has been lubricated during assembly. Additional lubrication is required every 120 miles of linear travel. The required lubricant is Festo GEL, available in a 14.5 ounce cartridge for grease guns.

Part No. 13000257.

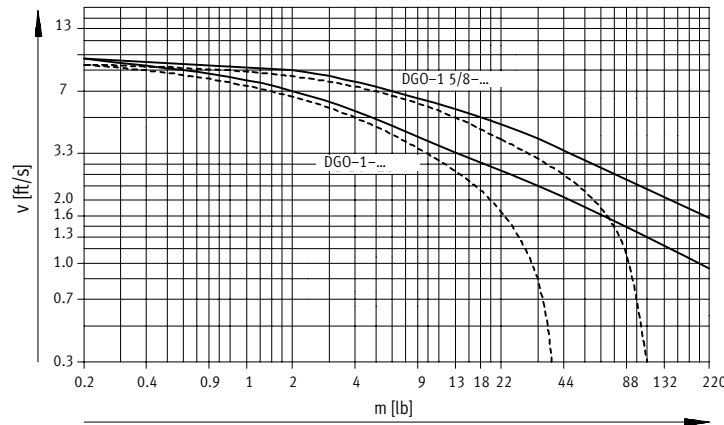
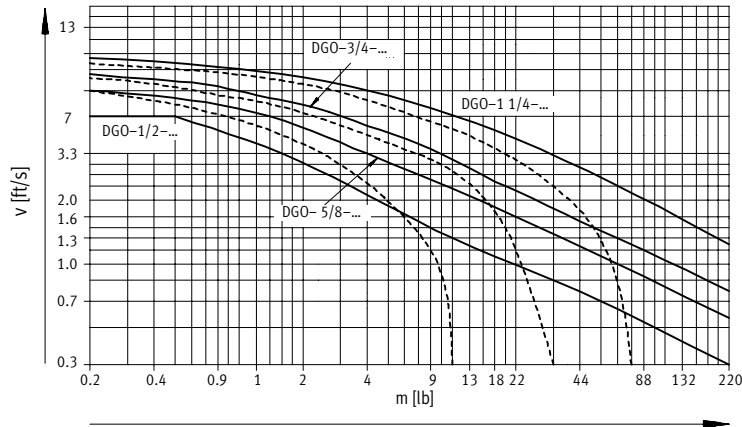

— Horizontal mounting position
 - - - - Vertical mounting position

Contactless position sensing

Mounting the proximity sensors SMEO-/SMTO-/SMPO-1

Installation of proximity sensors, Types SMEO, SMTO and SMPO for sensing end and intermediate positions. Proximity sensors are mounted by the user near the rodless cylinder (1/4 in / 6 mm diameter rod may be used). Sensing is possible only in the indicated area of the outer yoke [2]. If sensing distance A is too small, multiple sensing may result.

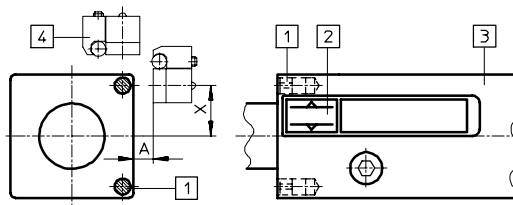

- 1 Switching magnet for proximity sensor
- 2 Switching range
- 3 Outer slide 360° rotatable
- 4 Proximity sensor with mounting kit SMB-1

Switching distances, switching travel and hysteresis [in]

Proximity sensors	A	X						Switching travel	Hysteresis
		DGO-1/2-...	DGO-5/8-...	DGO-3/4-...	DGO-1-...	DGO-1-1/4-...	DGO-1-5/8-...		
SMEO-1, SMTO-1	0.24 ... 0.31	0.40 ... 0.43	0.51 ... 0.55	0.63 ... 0.67	0.79 ... 0.83	0.98 ... 1.02	1.26 ... 1.30	0.30 ... 0.51	0.04 ... 0.18
SMPO-1-H-B	0.20 ... 0.24							0.28 ... 0.59	0.02 ... 0.10

Rodless cylinders DGO - Inch Series

Technical data

FESTO

Dimensions

Piston $\varnothing 1/2$ inch

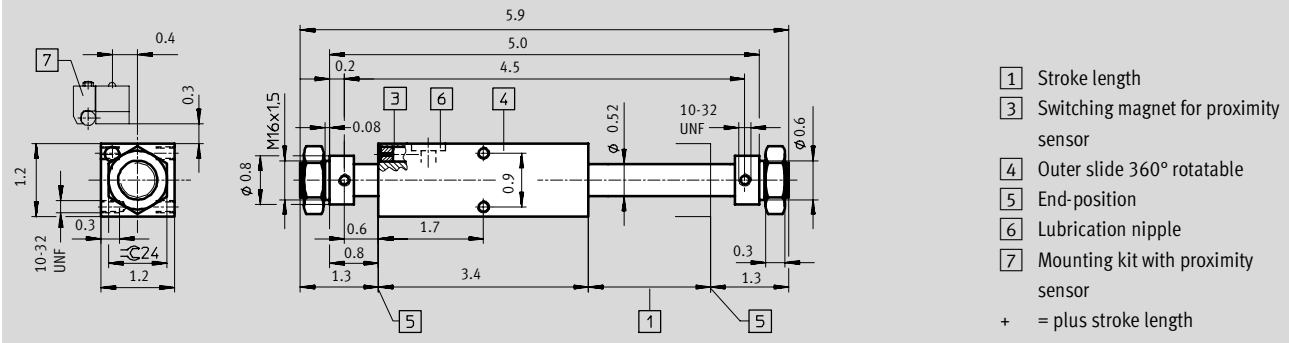

Piston $\varnothing 5/8... 1$ inch

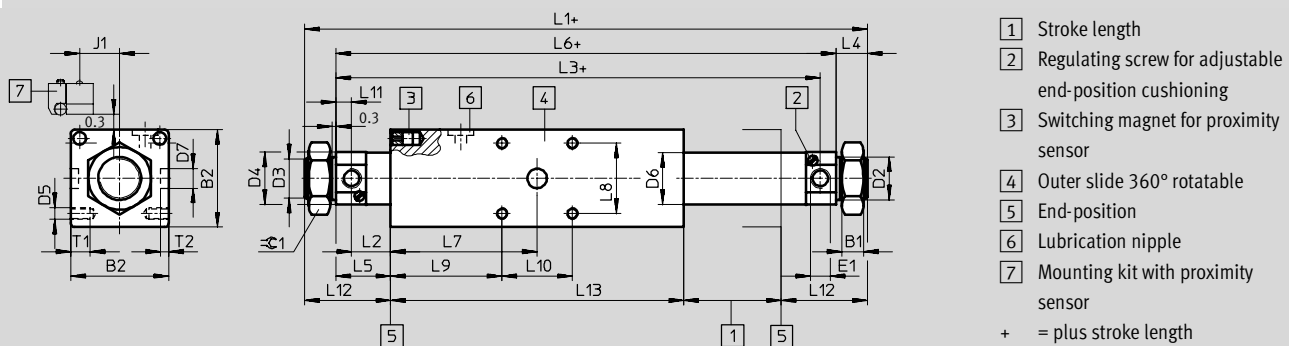

Piston $\varnothing 1-1/4... 1-5/8$ inch

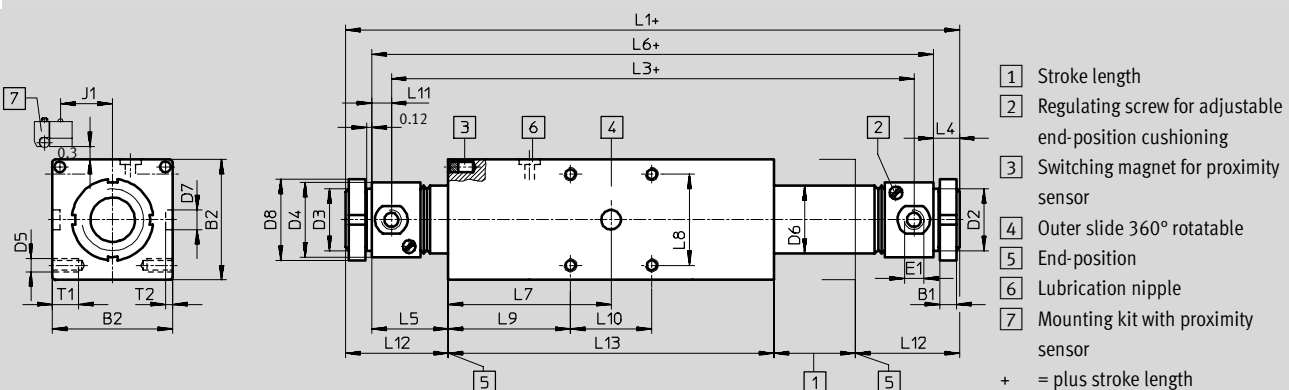

Dimensions are in inches, unless otherwise noted.

Rodless cylinders DGO - Inch Series

Technical data

Dimensions									
∅	B1	B2	D2 ∅	D3	D4 ∅	D5	D6 ∅	D7 ∅	D8 ∅
[in]									
5/8	0.31	1.4	0.6	M16x1.5	0.8	10-24 UNC	0.69	0.3	-
3/4	0.43	1.7	0.9	M22x1.5	1.1	10-24 UNC	0.84	0.3	-
1	0.43	2.0	0.9	M22x1.5	1.1	1/4-20 UNC	1.04	0.4	-
1-1/4	0.31	2.4	1.2	M30x1.5	1.5	1/4-20 UNC	1.32	0.4	1.7
1-5/8	0.39	2.9	1.5	M38x1.5	1.8	5/16-18 UNC	1.68	0.5	2.0

∅	E1	J1	L1	L2	L3	L4	L5	L6	L7
[in]									
5/8	10-32 UNF	0.53	8.1	0.5	5.9	0.5	1.1	7.1	2.5
3/4	1/8" NPT	0.65	8.5	0.6	6.7	0.6	1.0	7.3	2.7
1	1/8" NPT ¹⁾	0.81	9.4	0.8	7.5	0.6	1.1	8.1	3.0
1-1/4	1/8" NPT	1.00	10.6	0.9	8.6	0.6	1.3	9.4	3.3
1-5/8	1/4" NPT	1.26	12.9	1.4	10.7	0.6	1.9	11.6	3.9

∅	L8	L9	L10	L11	L12	L13	T1	T2	∅C1
[in]									[mm]
5/8	1.0	1.9	1.0	0.6	1.6	4.9	0.3	0.2	24
3/4	1.3	2.0	1.3	0.3	1.6	5.3	0.4	0.1	32
1	1.4	2.2	1.4	0.3	1.7	5.9	0.4	0.2	32
1-1/4	1.9	2.4	1.9	0.4	1.9	6.7	0.5	0.2	-
1-5/8	2.2	3.0	2.0	0.5	2.5	7.9	0.6	0.2	-

1) Max. screw-in depth 0.28 inch.

Dimensions are in inches, unless otherwise noted.

Rodless cylinders DGO - Inch Series

Ordering Data

M Mandatory data				
Function	Piston Ø	Stroke	Cushioning	Magnet for position sensing
DGO	1/2 5/8 3/4 1 1 1/4 1 5/8	0.4 ... 157	P PPV	A
DGO	- 1	- 100	- PPV	- A

Ordering table								
Size	1/2	5/8	3/4	1	1 1/4	1 5/8	Code	Enter code
M Function	Standard cylinder, single-acting pushing						DGO	DGO
Piston Ø [in]	1/2	5/8	3/4	1	1 1/4	1 5/8	-...	
Stroke [in]	0.4 ... 47	0.4 ... 98	0.4 ... 118	0.4 ... 137		0.4 ... 157	-...	
Cushioning [in]	Flexible cushioning rings at both ends	-	-	-	-	-	-P	
	-	Adjustable air cushioning at both ends				-	-PPV	
Magnet for position sensing	For use with magnetic proximity sensors						-A	-A

Transfer order code

DGO - - - - - **A**

Rodless cylinders DGO - Inch Series

Accessories

Moment compensator FKG

for piston \varnothing 5/8 ... 1-5/8 inch

The yoke mounting bracket prevents moment arm torque on the yoke by transferring the torque force to the centerline of the yoke. This greatly reduces the force lost to bearing friction and compensates for non-parallel alignment.

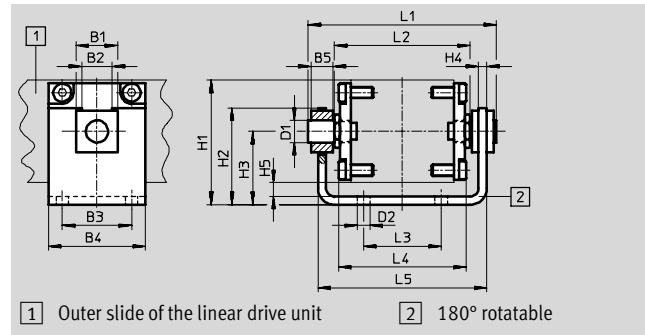

Maximum permissible misalignment of parallel guide in longitudinal axis of cylinder = 0.04 inch.

Includes: 1 moment compensator and 8 mounting screws

Material:

Galvanized steel

Dimensions and ordering data																					
For \varnothing	B1	B2	B3	B4	B5	D1	D2	H1	H2	H3	H4	H5	L1	L2	L3	L4	L5	CRC ¹⁾	Weight	Part No.	Type
[in]						\varnothing	\varnothing												[oz]		
5/8	0.7	0.6	1.0	1.6	0.3	0.4	0.22	1.9	1.6	1.1	0.2	0.3	2.9	2.1	1.0	1.9	2.7	2	9.07	15233	FKG-16-B
3/4	0.7	0.6	1.3	1.7	0.3	0.4	0.22	2.1	1.7	1.3	0.2	0.3	3.2	2.4	1.3	2.2	3.0	2	10.65	33339	FKG-20-B
1	0.9	0.6	1.4	2.0	0.5	0.5	0.26	2.5	2.0	1.5	0.2	0.3	3.9	2.8	1.4	2.5	3.5	2	18.02	15234	FKG-25-B
1-1/4	0.9	0.6	1.9	2.4	0.5	0.5	0.26	2.9	2.2	1.7	0.2	0.3	4.3	3.1	1.9	2.9	3.9	2	23.88	33340	FKG-32-B
1-5/8	1.2	0.9	2.0	2.8	0.6	0.6	0.35	3.5	2.8	2.1	0.2	0.4	5.3	3.9	2.2	3.6	4.8	2	45.04	15235	FKG-40-B

1) Corrosion resistance class 2 according to Festo standard 940 070
Components with moderate corrosion resistance for use in normal industrial environments subjected to contact with coolants or lubricating agents.

Foot mounting HBN

for piston \varnothing 1/2 ... 1 inch

Material:

Galvanized steel

Free of copper, PTFE and silicone

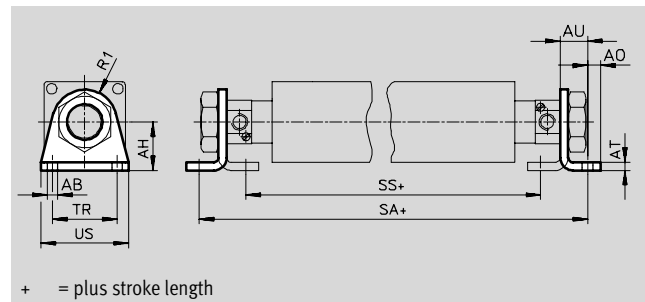

Dimensions and ordering data														
For \varnothing	AB	AH	AO	AT	AU	R1	SA	SS	TR	US	CRC ¹⁾	Weight	Part No.	Type
[in]	\varnothing											[oz]		
1/2	0.22	0.8	0.2	0.2	0.6	0.5	6.0	4.1	1.3	1.7	2	1.41	5125	HBN-12/16x1
5/8	0.22	1.1	0.2	0.2	0.6	0.5	8.2	6.3	1.3	1.7	2	1.76	6062	HBN-12/16x1-A
3/4	0.26	1.2	0.3	0.2	0.7	0.8	8.6	6.3	1.6	2.1	2	3.53	6064	HBN-20/25x1-A
1	0.26	0.9	0.3	0.2	0.7	0.8	9.4	7.2	1.6	2.1	2	3.53	6064	HBN-20/25x1-A

1) Corrosion resistance class 2 according to Festo standard 940 070
Components with moderate corrosion resistance for use in normal industrial environments subjected to contact with coolants or lubricating agents.

Dimensions are in inches, unless otherwise noted.

Rodless cylinders DGO - Inch Series

Accessories

FESTO

Flange mounting FBN

for piston \varnothing 1/2 ... 1 inch

Material:

Galvanized steel

Free of copper, PTFE and silicone

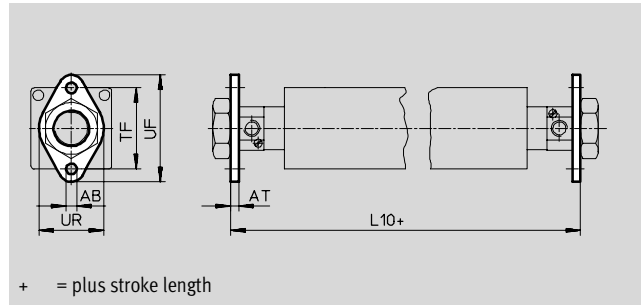
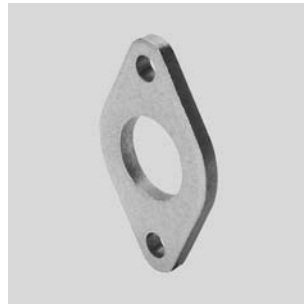

Dimensions and ordering data												
For \varnothing [in]	AB \varnothing	AT	L10	TF	UF	UR	US	CRC ¹⁾	Weight [oz]	Part No.	Type	
1/2	0.22	0.2	5.2	1.6	2.1	1.2	1.7	2	0.88	5130	FBN-12/16	
5/8	0.22	0.2	7.4	1.6	2.1	1.2	1.7	2	0.88	5130	FBN-12/16	
3/4	0.26	0.2	7.4	2.0	2.6	1.6	2.1	2	1.59	5131	FBN-20/25	
1	0.26	0.2	8.5	2.0	2.6	1.6	2.1	2	1.59	5131	FBN-20/25	

1) Corrosion resistance class 2 according to Festo standard 940 070

Components with moderate corrosion resistance for use in normal industrial environments subjected to contact with coolants or lubricating agents.

Flange mounting FBN

for piston \varnothing 1-1/4 ... 1-5/8 inch

Material:

Galvanized steel

Free of copper, PTFE and silicone

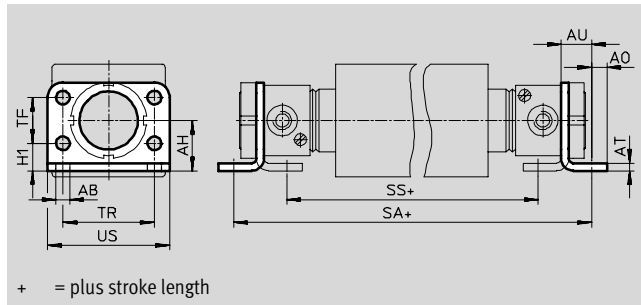

Dimensions and ordering data															
For \varnothing [in]	AB \varnothing	AH	AO	AT	AU	H1	SA	SS	TF	TR	US	CRC ¹⁾	Weight [oz]	Part No.	Type
1-1/4	0.3	1.1	0.3	0.2	0.6	0.6	10.5	8.6	1.1	2.0	2.6	2	3.6	195855	FBN-32
1-5/8	0.4	1.3	0.4	0.2	0.7	0.7	13.2	10.4	1.2	2.4	3.1	2	6.7	195856	FBN-40

1) Corrosion resistance class 2 according to Festo standard 940 070

Components with moderate corrosion resistance for use in normal industrial environments subjected to contact with coolants or lubricating agents.

Dimensions are in inches, unless otherwise noted.

Rodless cylinders DGO - Inch Series



Accessories

Ordering data – Rectangular proximity sensor, magneto-resistive							
	Mounting	Switch output	Electrical connection		Cable length [ft]	Part No.	Type
			Cable	M8 plug			
NO contact							
	Via mounting kit	PNP	3-wire	–	8.2	151683	SMTO-1-PS-K-LED-24-C
			–	3-pin	–	151685	SMTO-1-PS-S-LED-24-C
		NPN	3-wire	–	8.2	151684	SMTO-1-NS-K-LED-24-C
			–	3-pin	–	151686	SMTO-1-NS-S-LED-24-C

Ordering data – Rectangular proximity sensor, magnetic reed						
	Mounting	Electrical connection		Cable length [ft]	Part No.	Type
		Cable	M8 plug			
NO contact						
	Via mounting kit	3-wire	–	8.2	30459	SMEO-1-LED-24-B
		3-wire	–	16.4	151672	SMEO-1-LED-24-K5-B
		–	3-pin	–	150848	SMEO-1-S-LED-24-B

Ordering data – Rectangular proximity sensor, pneumatic						
	Mounting	Pneumatic connection			Part No.	Type
3/2-way valve, normally closed						
	Via mounting kit	Barbed fitting for 1/8 inch tubing ID			31008	SMPO-1-H-B

Ordering data – Mounting kit							
	Mounting					Part No.	Type
	For cylinder with tie rod \varnothing 1/4 inch or DUO rail mounting profile				11886	SMB-1	

Ordering data – Plug sockets							
	Mounting	Switch output		Connection	Cable length [ft]	Part No.	Type
		PNP	NPN				
Straight socket							
	M8 union nut	■	■	3-pin	8.2	159420	SIM-M8-3GD-2.5-PU
					16.4	159421	SIM-M8-3GD-5-PU
Angled socket							
	M8 union nut	■	■	3-pin	8.2	159422	SIM-M8-3WD-2.5-PU
					16.4	159423	SIM-M8-3WD-5-PU

Ordering data – One-way flow control valves						
	Connection			Part No.	Type	
	Thread	For tubing OD				
	10-32 UNF	3/16"	151573	GRLA-10-UNF-3/16-B		
		1/4"	151574	GRLA-10-UNF-1/4-B		
	1/8" NPT	5/32"	165009	GRLA-1/8-NPT-QS-5/32-U		
		3/16"	190941	GRLA-1/8-NPT-QS-3/16-U		
		1/4"	165010	GRLA-1/8-NPT-QS-1/4-U		
		5/16"	165013	GRLA-1/8-NPT-QS-5/16-U		
	1/4" NPT	3/16"	190944	GRLA-1/4-NPT-QS-3/16-U		
		1/4"	165011	GRLA-1/4-NPT-QS-1/4-U		
		5/16"	165014	GRLA-1/4-NPT-QS-5/16-U		
		3/8"	190947	GRLA-1/4-NPT-QS-3/8-U		