

Compact cylinders ADVU - Inch Series



- Piston Ø 1/2" to 5"
- Stroke lengths up to 16"
- Double-acting versions
- Compact design – less space required
- Numerous options
- Repairable

Product range overview											
Function	Version	Piston Ø [in]	Stroke [in]	Force [lbf]	Variants						
					A	P	A	S2	S6	S20	S26
Double-acting	Basic version										
	ADVU	1/2, 5/8, 3/4, 1, 1-1/4, 1-5/8, 2, 2-1/2, 3, 4, 5	0.04 ... 16	15.3 ... 1,655	■	■	■	■	■	■	■

Variants										
A	Male thread	A	Magnet for position sensing	S6	Heat-resistant seals up to 302 °F	S26	Through piston rod, with heat-resistant seals up to 302 °F			
P	Flexible cushioning rings at both ends	S2	Through piston rod	S20	Through, hollow piston rod					

Compact cylinders ADVU - Inch Series

Product range overview



Function	Version	Type	Piston \varnothing [in]	Standard strokes [in]	Variable strokes [in]	Magnet for position sensing A
Double-acting	Basic version					
		ADVU Piston rod at one end	1/2, 5/8	1/4, 1/2, 3/4, 1, 1-1/4, 1-1/2	0.04 ... 8	■
			3/4, 1	1/4, 1/2, 3/4, 1, 1-1/4, 1-1/2, 2	0.04 ... 8	
			1-1/4, 1-5/8	1/4, 1/2, 3/4, 1, 1-1/4, 1-1/2, 2, 2-1/2, 3	0.04 ... 12	
			2, 2-1/2	1/2, 3/4, 1, 1-1/4, 1-1/2, 2, 2-1/2, 3	0.04 ... 12	
			3, 4, 5	1/2, 3/4, 1, 1-1/4, 1-1/2, 2, 2-1/2, 3	0.04 ... 16	

Compact cylinders ADVU - Inch Series

Product range overview

Type	Piston rod		Through piston rod S2	Through hollow piston rod S20	Heat resistant seals up to 302 °F S6	Through piston rod, heat resistant seals up to 302 °F S26
	with female thread	with male thread				
Basic version						
ADVU Piston rod at one end	■	■	■	■ ∅ 1/2 ... 4	■	■ ∅ 1/2 ... 4

Compact cylinders ADVU - Inch Series

Technical data – Double-acting, basic version

FESTO

Double-acting

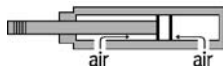

- Through piston rod (S2)
- Through, hollow piston rod (S20)
- Heat resistant seals (S6)
- Through piston rod, heat resistant seals (S26)

∅ - Diameter
1/2 ... 5 inch

— Stroke length
0.04 ... 16 inch

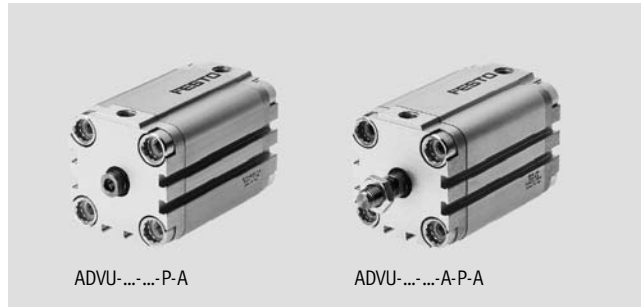

ADVU-...-P-A

ADVU-...-A-P-A

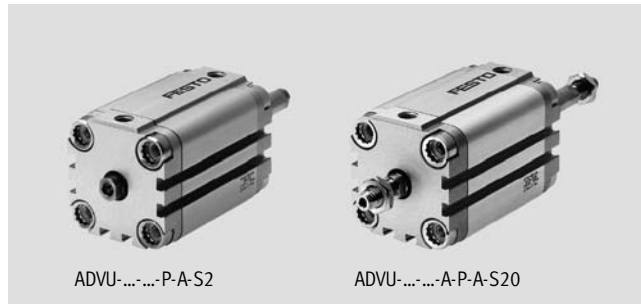

ADVU-...-P-A-S2

ADVU-...-A-P-A-S20

General technical data												
Piston ∅		1/2	5/8	3/4	1	1-1/4	1-5/8	2	2-1/2	3	4	5
Pneumatic connection		10-32 UNF				1/8" NPT					1/4" NPT	
End of piston rod	Female thread	4-48 UNF-2B	8-36 UNF-2B	10-32 UNF-2B		1/4-28 UNF-2B		5/16-24 UNF-2B		3/8-24 UNF-2B	1/2-20 UNF-2B	5/8-18 UNF-2B
	Male thread	10-32 UNF-2A	5/16-24 UNF-2A	3/8-24 UNF-2A			1/2-20 UNF-2A		5/8-18 UNF-2A	3/4-16 UNF-2A	1-12 UNF-2A	
Operating medium		Filtered compressed air, lubricated or unlubricated										
Constructional design		Piston										
		Piston rod										
Cushioning		Flexible cushioning rings at both ends										
Magnet for position sensing ¹⁾		Standard										

1) Position sensing via magnetic proximity sensor (ordered separately, see accessories).

Operating pressure [psi]												
Piston ∅		1/2	5/8	3/4	1	1-1/4	1-5/8	2	2-1/2	3	4	5
Piston rod at one end		17.6 ... 176.0		14.7 ... 147.0		11.8 ... 147.0		8.8 ... 147.0		7.4 ... 147		
Through piston rod S2/S20		22.1 ... 147.0		19.1 ... 147.0		14.7 ... 147.0		11.8 ... 147.0		7.4 ... 147.0		

Ambient conditions			
Variant		Basic version	S6
Ambient temperature ¹⁾	[°F]	-4 ... +176	32 ... +302
Corrosion resistance class CRC ²⁾		2	2

1) Note operating range of proximity sensors.

2) Corrosion resistance class 2 according to Festo standard 940 070

Components with moderate corrosion resistance for use in normal industrial environments subjected to contact with coolants or lubricating agents.

Compact cylinders ADVU - Inch Series

Technical data – Double-acting, basic version

Forces [lbf] and impact energy [ft-lbf]											
Piston Ø	1/2	5/8	3/4	1	1-1/4	1-1/2	2	2-1/2	3	4	5
Theoretical force at 90 psi, extending	15.3	27.2	42.3	66.4	108.7	169.7	265	420.8	678.6	1060.2	1655.3
	S2/S20	15.3	27.2	42.3	66.4	108.7	169.7	265	420.8	678.6	1060.2
Theoretical force at 90 psi, retracting	15.3	27.2	42.3	66.4	108.7	169.7	265	420.8	678.6	1060.2	1655.3
	S2/S20	15.3	27.2	42.3	66.4	108.7	169.7	265	420.8	678.6	1060.2
Max. impact energy at end positions (E _{perm})	0.07	0.07	0.10	0.07	0.30	0.38	0.47	0.52	0.55	0.74	2.95
	S20	0.01	0.01	0.01	0.01	0.03	0.04	0.04	0.05	0.06	0.07

Permissible impact velocity:
$$v_{perm.} = \sqrt{\frac{2 \times 32.2 \times E_{perm.}}{m_{piston} + m_{load}}}$$

Maximum permissible load:
$$m_{load} = \frac{2 \times 32.2 \times E_{perm.}}{v^2} - m_{piston}$$

Notes

m_{piston} equals mass of cylinder moving parts

m_{load} equals mass of external load

This data represents the maximum values that can be achieved. Values fluctuate in practice relative to the size of the effective load. Allowance must also be made for the limits of the cushioning capacity of the drive and the permissible impact energy.

Mass [lb]											
Piston Ø	1/2	5/8	3/4	1	1-1/4	1-5/8	2	2-1/2	3	4	5
Product mass with 0 inch stroke	0.19	0.19	0.33	0.40	0.66	0.96	1.24	2.34	3.91	6.17	7.56
Additional mass per 1 inch stroke	0.08	0.08	0.13	0.16	0.23	0.33	0.41	0.60	0.94	0.99	0.94
Moving load with 0 inch stroke (m _{piston})	0.02	0.03	0.04	0.06	0.11	0.14	0.25	0.29	0.68	1.36	2.91
Additional load per 1 inch stroke (m _{piston})	0.01	0.01	0.01	0.01	0.02	0.02	0.04	0.04	0.06	0.08	0.14

Max. lateral force F_q as a function of the projection x

Piston rod at one end

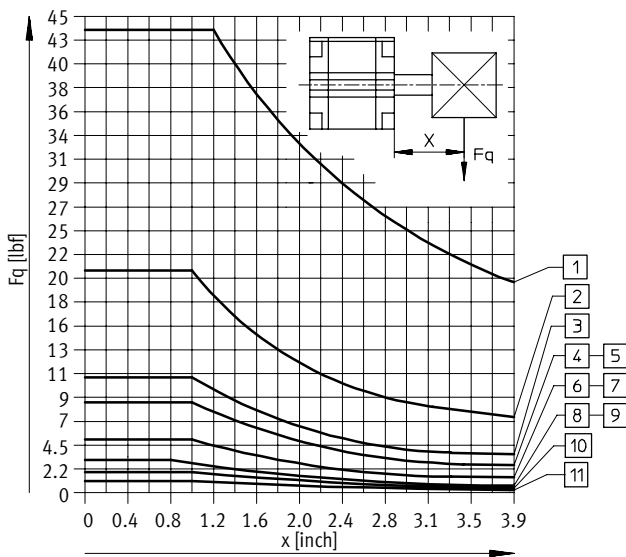

Through piston rod

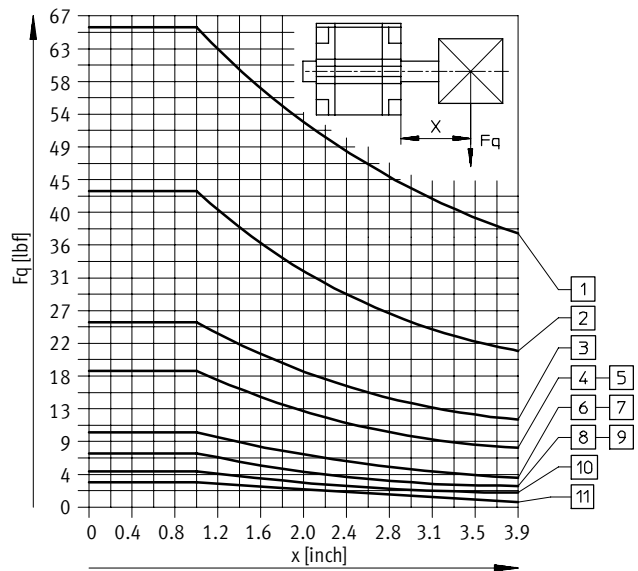

- 1 Ø 5 inch
- 2 Ø 4 inch
- 3 Ø 3 inch
- 4 Ø 2-1/2 inch
- 5 Ø 2 inch
- 6 Ø 1-5/8 inch
- 7 Ø 1-1/4 inch
- 8 Ø 1 inch

- 9 Ø 3/4 inch
- 10 Ø 5/8 inch
- 11 Ø 1/2 inch

Compact cylinders ADVU - Inch Series

Technical data – Double-acting, basic version

Materials

Sectional view

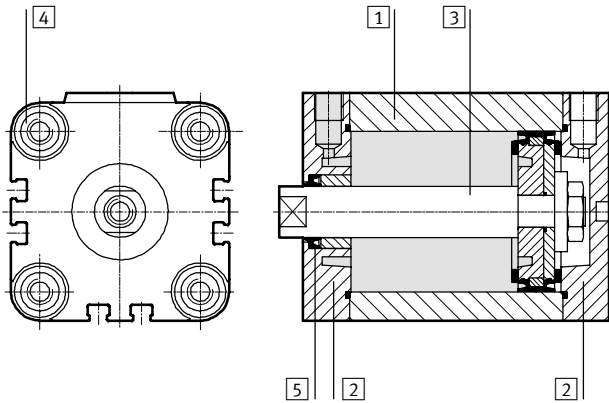

Variants	Basic version	S6
1 Cylinder barrel	Wrought aluminum alloy	Wrought aluminum alloy
2 End cap	Wrought aluminum alloy	Wrought aluminum alloy
3 Piston rod	∅ 1/2 ... 1-1/4	High-alloy stainless steel
	∅ 1-5/8 ... 5	High-alloy steel
4 Flange screws	∅ 1/2 ... 5/8	High-alloy stainless steel
	∅ 3/4 ... 5	Tempered steel
5 Dynamic seals	Polyurethane	Fluorocarbon rubber

Compact cylinders ADVU - Inch Series

Technical data – Double-acting, basic version

Dimensions – Basic cylinder

Piston \varnothing 1/2 ... 4 inch

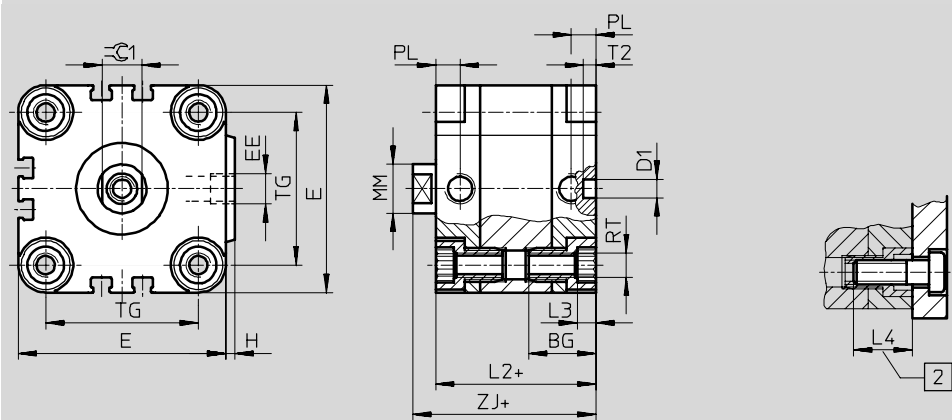

Note

To attach cylinder \varnothing 1/2 and 5/8 inch from above, use only 2 screws diagonally or non-magnetic screws.

+ = plus stroke length

2 Minimum screw-in depth

Piston \varnothing 5 inch

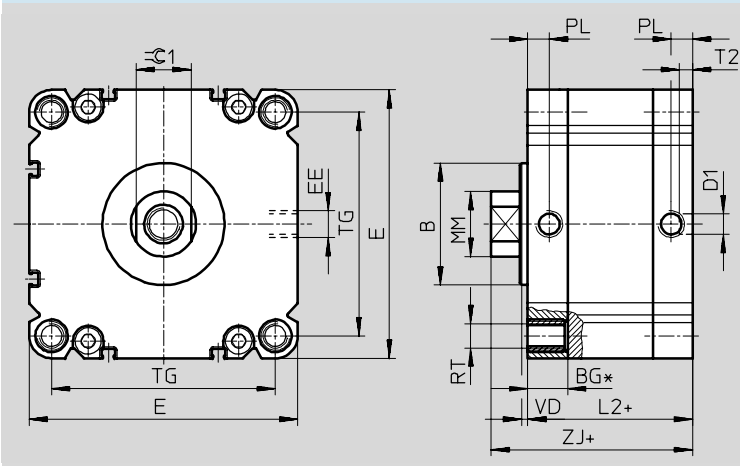

* Minimum screw-in depth 0.7 inch.
Cannot be screwed through with socket head screws.

+ = plus stroke length

\varnothing [in]	B	BG	D1 \varnothing	E	EE	H	L2	L3	L4	MM \varnothing	PL	RT	T2	TG	VD	ZJ	$\approx C1$ [mm]
1/2	-	0.7	0.2	1.1	10-32 UNF	0.04	1.5	0.1	0.6	0.2	0.3	M4	0.2	0.7	-	1.7	5
5/8	-	0.7	0.2	1.1	10-32 UNF	0.04	1.5	0.1	0.6	0.3	0.3	M4	0.2	0.7	-	1.7	7
3/4	-	0.7	0.2	1.4	10-32 UNF	0.06	1.5	0.2	0.7	0.4	0.3	M5	0.2	0.9	-	1.7	9
1	-	0.7	0.2	1.6	10-32 UNF	0.06	1.6	0.2	0.7	0.4	0.3	M5	0.2	1.0	-	1.8	9
1-1/4	-	0.8	0.2	2.0	1/8" NPT	0.08	1.8	0.2	0.8	0.5	0.3	M6	0.2	1.3	-	2.0	10
1-5/8	-	0.8	0.2	2.4	1/8" NPT	0.10	1.8	0.2	0.8	0.5	0.3	M6	0.2	1.7	-	2.0	10
2	-	0.9	0.2	2.7	1/8" NPT	0.12	1.8	0.2	0.8	0.6	0.3	M8	0.2	2.0	-	2.1	13
2-1/2	-	1.0	0.3	3.4	1/8" NPT	0.16	2.0	0.3	1.0	0.6	0.3	M10	0.2	2.4	-	2.3	13
3	-	1.1	0.3	4.2	1/8" NPT	0.16	2.2	0.3	1.0	0.8	0.3	M10	0.2	3.2	-	2.5	17
4	-	1.3	0.3	5.0	1/4" NPT	0.20	2.6	0.3	1.0	1.0	0.4	M10	0.2	4.1	-	3.0	22
5	2.4	0.8	0.4	5.2	1/4" NPT	-	3.2	-	0.7	1.3	0.4	M12	0.2	4.3	-	3.9	27

Dimensions are in inches, unless otherwise noted.

Compact cylinders ADVU - Inch Series

Technical data – Double-acting, basic version

Dimensions – Variants

Basic version



S2 – Through piston rod

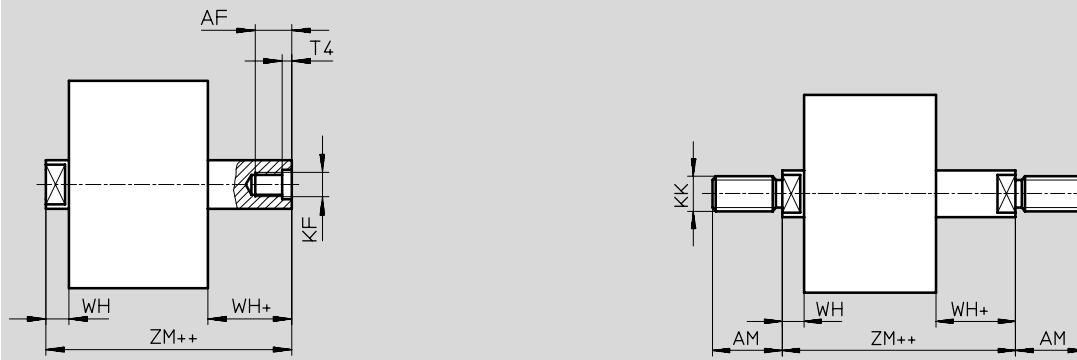

S20 – Through, hollow piston rod

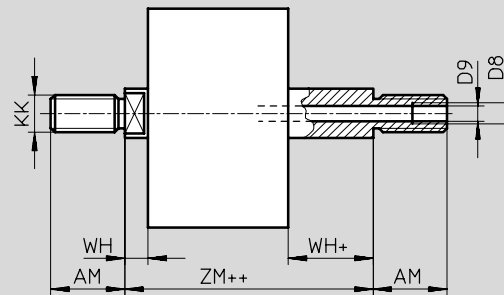

+ = plus stroke length
 ++ = plus 2x stroke length

∅ [in]	AF	AM	D8	D9 ∅	KF	KK	T4	WH	ZJ	ZM
1/2	0.3	0.6	–	0.1	4-48 UNF-2B	10-32 UNF-2A	0.1	0.2	1.7	1.9
5/8	0.4	0.8	–	0.1	8-36 UNF-2B	5/16-24 UNF-2A	0.1	0.2	1.7	1.9
3/4 ²⁾	0.5	0.9	–	0.1	10-32 UNF-2B	3/8-24 UNF-2A	0.1	0.2	1.7	1.9
1 ²⁾	0.5	0.9	–	0.1	10-32 UNF-2B	3/8-24 UNF-2A	0.1	0.2	1.8	2.0
1-1/4 ²⁾	0.6	0.9	–	0.2	1/4-28 UNF-2B	3/8-24 UNF-2A	0.1	0.2	2.0	2.2
1-5/8 ²⁾	0.6	0.9	–	0.2	1/4-28 UNF-2B	3/8-24 UNF-2A	0.1	0.3	2.0	2.3
2 ²⁾	0.6	0.9	–	0.2	5/16-24 UNF-2B	1/2-20 UNF-2A	0.1	0.3	2.1	2.4
2-1/2 ²⁾	0.6	0.9	–	0.2	5/16-24 UNF-2B	1/2-20 UNF-2A	0.1	0.3	2.3	2.6
3 ²⁾	0.8 ¹⁾	1.3	1/8" NPT	0.3	3/8-24 UNF-2B	5/8-18 UNF-2A	0.2	0.3	2.5	2.8
4 ²⁾	0.9 ¹⁾	1.6	1/4" NPT	0.5	1/2-20 UNF-2B	3/4-16 UNF-2A	0.2	0.4	3.0	3.4
5 ²⁾	1.0 ¹⁾	2.1	–	–	5/8-18 UNF-2B	1-12 UNF-2A	0.3	0.7	3.9	4.6

1) With a stroke < 0.2 inch, the maximum screw-in depth is reduced by 0.2 inch.
 2) Nut for piston rod thread included in scope of delivery.

Dimensions are in inches, unless otherwise noted.

Compact cylinders ADVU - Inch Series

Ordering Data

M Mandatory data					O Options	
Function	Piston Ø	Stroke	Cushioning	Magnet for position sensing	Type of piston rod	Temperature Resistant
ADVU	1/2 5/8 3/4 1 1 1/4 1 5/8 2 2 1/2 3 4 5	0.04 ... 16	P	A	S2 S20	S6 S26
ADVU	- 1	- 6	- P	- A	- S26	

Ordering table														
Size	1/2	5/8	3/4	1	1 1/4	1 5/8	2	2 1/2	3	4	5	Conditions	Code	Enter code
M Function	Double-acting Cylinder												ADVU	ADVU
Piston Ø [in]	1/2	5/8	3/4	1	1 1/4	1 5/8	2	2 1/2	3	4	5		-...	
Stroke [in]	0.04 ... 8			0.04 ... 13				0.04 ... 16					-...	
Cushioning	Flexible cushioning rings at both ends												-P	-P
Magnet for position sensing	For use with magnetic proximity sensor												-A	-A
O Type of piston rod	Through piston rod												-S2	
	Through, Hollow Piston Rod											1	-S20	
Temperature resistant	Heat-resistant seals up to max. 302 °F												-S6	
	Through piston rod, heat resistant up to max. 302 °F											2	-S26	

- 1 Not in combination with S6
- 2 S2 in combination with S6 equals S26

Transfer order code

- - - - -

Compact cylinders ADVU - Inch Series

Accessories overview



Piston \varnothing 1/2 ... 4 inch

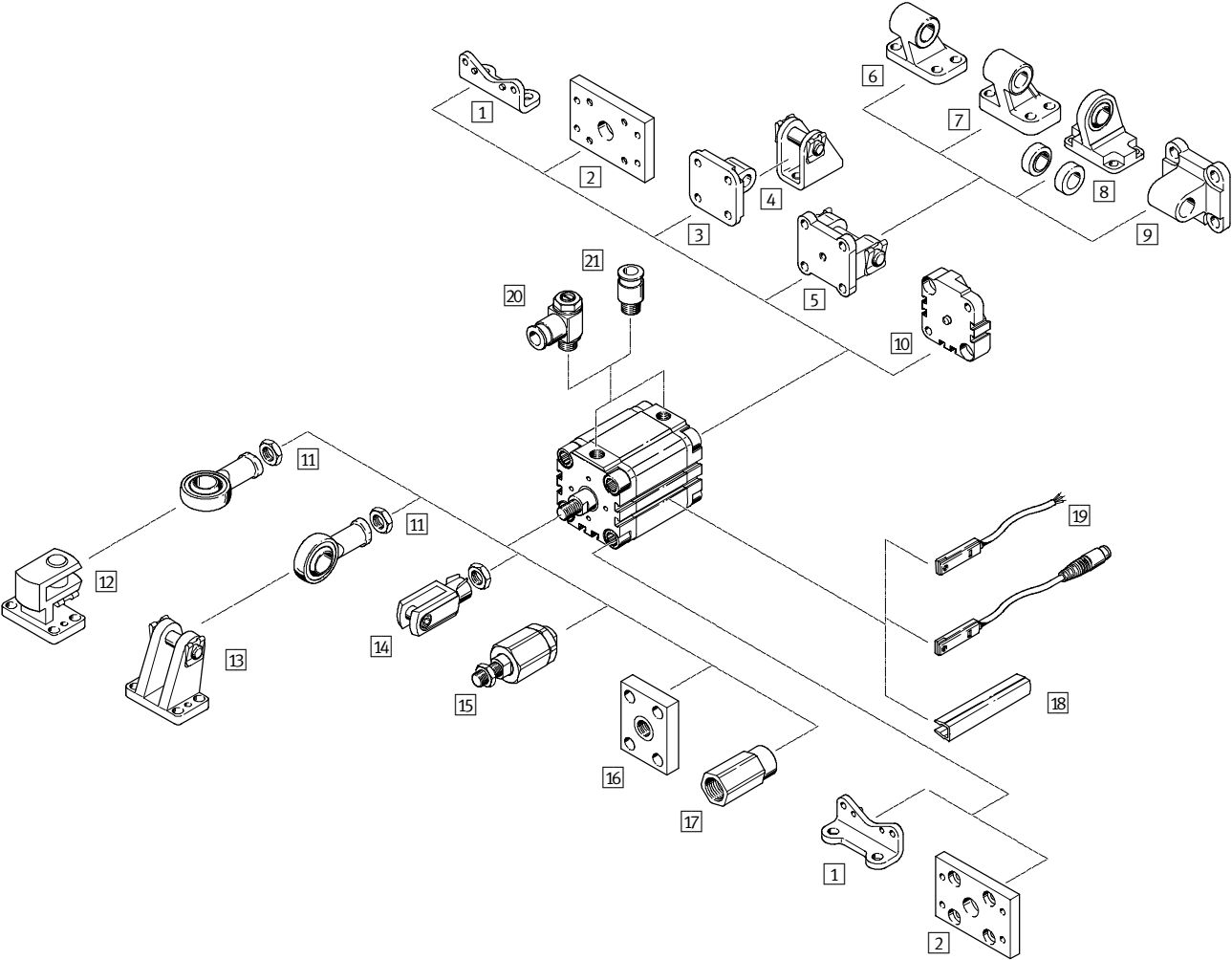

Compact cylinders ADVU - Inch Series

Accessories overview

FESTO

Mounting attachments and accessories				
	Description	ADVU		
		Basic	S2/S20	
1	Foot mounting HUA	For bearing and end cap	■	■
2	Flange mounting FUA	For bearing or end cap	■	■
3	Swivel flange SUA for $\varnothing 1/2 \dots 1$	For end cap	■	-
4	Clevis foot LBN	-	■	-
5	Swivel flange SUA for $\varnothing 1-1/4 \dots 4$	For end cap	■	-
6	Clevis foot LN	-	■	-
7	Clevis foot LNG	-	■	-
8	Clevis foot LSN	With spherical bearing	■	-
9	Swivel flange SNCL	-	■	-
10	Adapter kit DPVU	For connecting two cylinders with identical piston \varnothing to form a multi-position cylinder	■	-
11	Rod eye SGS	With spherical bearing	■	■
12	Clevis foot, lateral LQG	-	■	■
13	Clevis foot LBG	-	■	■
14	Rod clevis SG	Permits a swivelling movement of the cylinder in one plane	■	■
15	Self-aligning rod coupler FK	For compensating radial and angular deviations	■	■
16	Coupling piece KSZ	For cylinders with non-rotating piston rod for compensating radial deviations	-	-
17	Adapter AD	For vacuum generator	-	■ S20
18	Slot cover ABP-5-S	For protecting the sensor cable and keeping dirt out of the sensor slots	■	■
19	Proximity sensor SME/SMT-8	Can be integrated in the cylinder profile barrel	■	■
20	One-way flow control valve GRLA/GRLZ	For speed regulation	■	■
21	Push-in fitting QS	For connecting compressed air tubing with standard O.D.	■	■

Compact cylinders ADVU - Inch Series

Accessories overview

FESTO

Piston \varnothing 5 inch

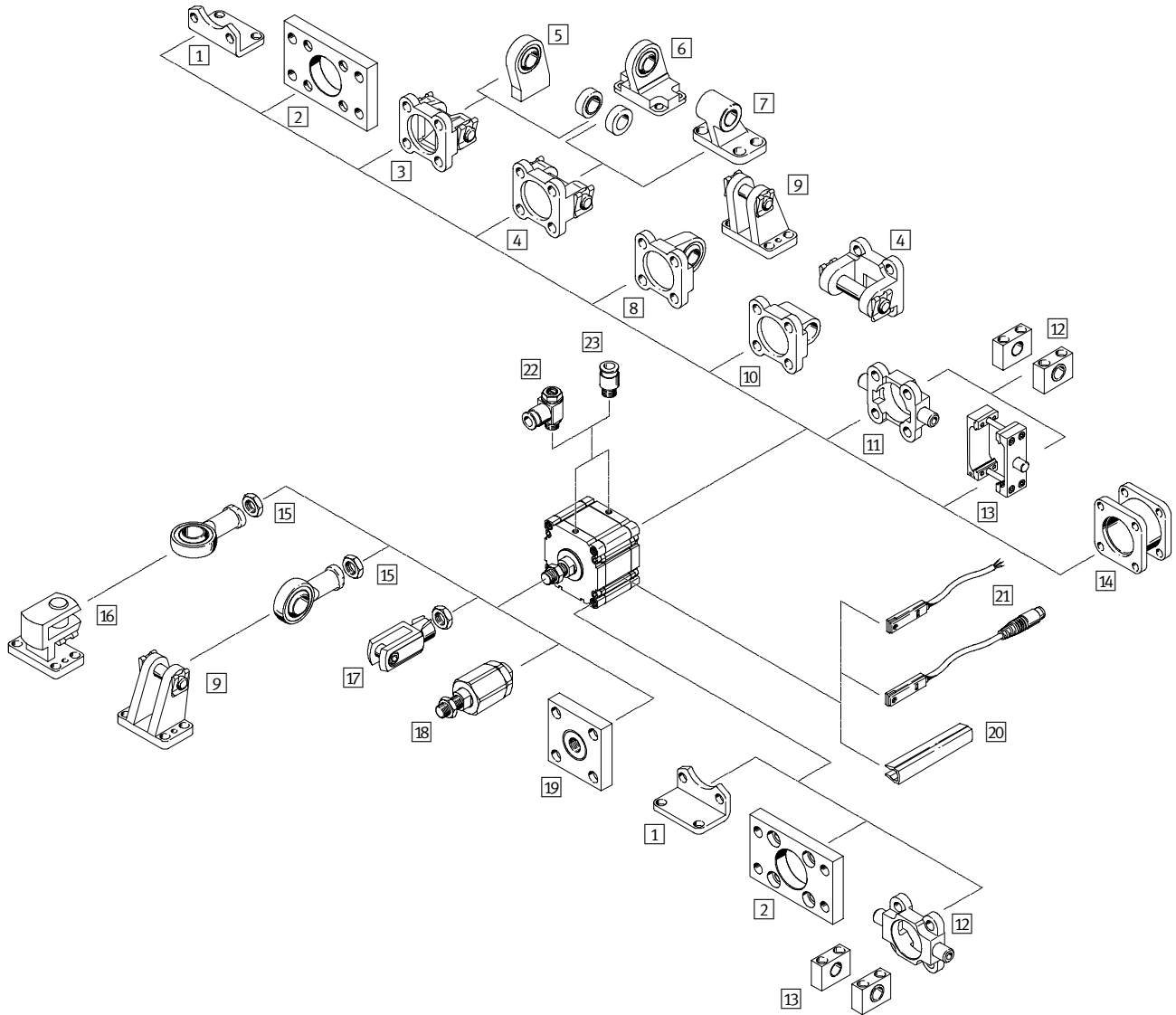

Compact cylinders ADVU - Inch Series

Accessories overview

FESTO

Mounting attachments and accessories				
	Description	ADVU		
		Basic	S2	
1	Foot mounting HNC	For bearing and end cap	■	■
2	Flange mounting FNC	For bearing or end cap	■	■
3	Swivel flange SNC	For end cap	■	-
4	Swivel flange SNCB	For end cap	■	-
5	Clevis foot LSNSG	Weld-on, with spherical bearing	■	-
6	Clevis foot LSN	With spherical bearing	■	-
7	Clevis foot LN	-	■	-
8	Swivel flange SNCS	With spherical bearing for end cap	■	-
9	Clevis foot LBG	-	■	■
10	Swivel flange SNCL	For end cap	■	-
11	Trunnion flange ZNCF	For bearing or end cap	■	■
12	Trunnion support LNZG	-	■	■
13	Trunnion mounting kit ZNCM	For mounting anywhere along the cylinder profile barrel	■	■
14	Adapter kit DPNC	For connecting two cylinders with identical piston \varnothing to form a multi-position cylinder	■	■
15	Rod eye SGS	With spherical bearing	■	■
16	Clevis foot, lateral LQG	-	■	■
17	Rod clevis SG	Permits a swivelling movement of the cylinder in one plane	■	■
18	Self-aligning rod coupler FK	For compensating radial and angular deviations	■	■
19	Coupling piece KSG	For compensating radial deviations	■	■
20	Slot cover ABP-5-S	For protecting the sensor cable and keeping dirt out of the sensor slots	■	■
21	Proximity sensor SME/SMT-8	Can be integrated in the cylinder profile barrel	■	■
22	One-way flow control valve GRLA/GRLZ	For speed regulation	■	■
23	Push-in fitting QS	For connecting compressed air tubing with standard O.D.	■	■

Compact cylinders ADVU - Inch Series

Accessories

FESTO

Foot mounting HUA

for piston \varnothing 1/2 ... 4 inch

Foot mounting HNC

for piston \varnothing 5 inch

(not illustrated)

Material:

HUA/HNC: Galvanized steel

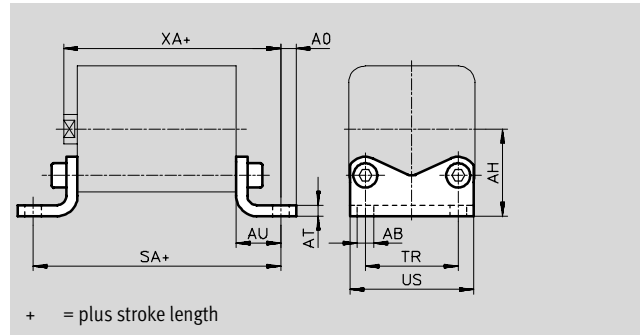

Dimensions									
For \varnothing	AB \varnothing	AH	AO	AT	AU	SA	TR	US	XA
1/2, 5/8	0.22	0.9	0.2	0.1	0.5	2.5	0.7	1.1	2.2
3/4	0.26	1.1	0.2	0.2	0.6	2.8	0.9	1.3	2.3
1	0.26	1.1	0.2	0.2	0.6	2.8	1.0	1.5	2.4
1-1/4	0.26	1.3	0.3	0.2	0.7	3.2	1.3	1.9	2.7
1-5/8	0.35	1.6	0.3	0.2	0.8	3.4	1.7	2.3	2.8
2	0.35	1.9	0.3	0.2	0.9	3.7	2.0	2.6	3.0
2-1/2	0.43	2.2	0.5	0.2	1.1	4.1	2.4	3.3	3.3
3	0.43	2.7	0.5	0.3	1.2	4.6	3.2	4.1	3.7
4	0.53	3.2	0.5	0.3	1.3	5.2	4.1	5.0	4.3
5	0.65	3.5	0.9	0.3	1.8	6.7	3.5	5.2	5.7

Ordering data				
For \varnothing	Weight [oz]	Basic version		
		CRC ¹⁾	Part No.	Type
1/2, 5/8	1.38	2	157309	HUA-12/16
3/4	2.75	2	157310	HUA-20
1	3.17	2	157311	HUA-25
1-1/4	5.47	2	157312	HUA-32
1-5/8	7.09	2	157313	HUA-40
2	11.08	2	157314	HUA-50
2-1/2	19.40	2	157315	HUA-63
3	29.10	2	157316	HUA-80
4	37.04	2	157317	HUA-100
5	65.08	2	174375	HNC-125

1) Corrosion resistance class 2 according to Festo standard 940 070
Components with moderate corrosion resistance for use in normal industrial environments subjected to contact with coolants or lubricating agents.

Dimensions are in inches, unless otherwise noted.

Compact cylinders ADVU - Inch Series

Accessories

Flange mounting FUA
for piston \varnothing 1/2 ... 4 inch

Flange mounting FNC
for piston \varnothing 5 inch
(not illustrated)

Material:

FUA: Clear anodized aluminum

FNC: Galvanized steel

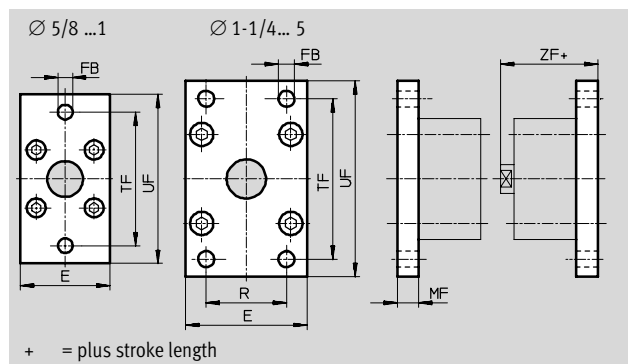

Dimensions and ordering data											
For \varnothing	E	FB \varnothing	MF	R	TF	UF	ZF	CRC ²⁾	Weight [oz]	Part No.	Type
1/2, 5/8	1.1	0.2	0.4	-	1.7	2.2	2.1	2	1.69	157299	FUA-12/16
3/4	1.4	0.3	0.4	-	2.2	2.8	2.1	2	2.54	157300	FUA-20
1	1.6	0.3	0.4	-	2.4	3.0	2.2	2	3.07	157301	FUA-25
1-1/4	2.0	0.3	0.4	1.3	2.6	3.1	2.4	2	4.13	157302	FUA-32
1-5/8	2.4	0.4	0.4	1.4	3.2	4.0	2.4	2	6.35	157303	FUA-40
2	2.7	0.4	0.5	1.8	3.5	4.3	2.6	2	9.38	157304	FUA-50
2-1/2	3.4	0.4	0.6	2.0	4.3	5.1	2.9	2	19.40	157305	FUA-63
3	4.2	0.5	0.6	2.5	5.3	6.3	3.0	2	26.28	157306	FUA-80
4	5.0	0.6	0.6	3.0	6.4	7.5	3.6	2	36.51	157307	FUA-100
5	5.2	0.6	0.8	3.5	7.1	8.3	4.7	2	132.28	174382	FNC-125 ¹⁾

1) Free of copper, PTFE and silicone

2) Corrosion resistance class 2 according to Festo standard 940 070

Components with moderate corrosion resistance for use in normal industrial environments subjected to contact with coolants or lubricating agents.

Dimensions are in inches, unless otherwise noted.

Compact cylinders ADVU - Inch Series

Accessories

FESTO

Swivel flange SUA

for piston \varnothing 1/2 ... 1 inch

Material:

SUA: Anodized aluminum

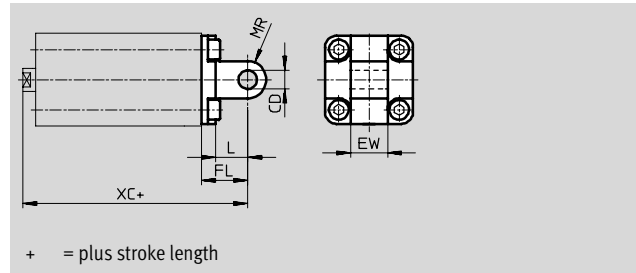

for piston \varnothing 1-1/4 ... 4 inch

Material:

SUA: Anodized aluminum

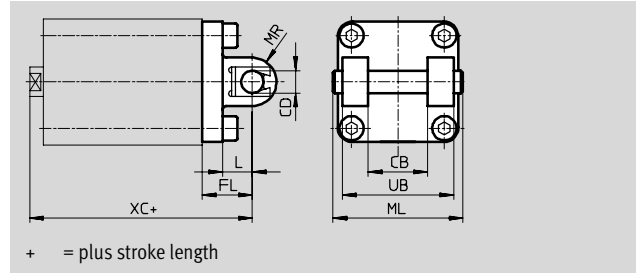

Dimensions									
For \varnothing	CB	CD \varnothing	EW	FL	L	ML	MR	UB	XC
1/2, 5/8	–	0.2	0.5	0.6	0.4	–	0.2	–	2.3
3/4	–	0.3	0.6	0.8	0.6	–	0.3	–	2.5
1	–	0.3	0.6	0.8	0.6	–	0.3	–	2.6
1-1/4	1.0	0.4	–	0.9	0.5	2.1	0.4	1.8	2.9
1-5/8	1.1	0.5	–	1.0	0.6	2.4	0.5	2.0	3.0
2	1.3	0.5	–	1.1	0.6	2.8	0.5	2.4	3.1
2-1/2	1.6	0.6	–	1.3	0.8	3.2	0.6	2.8	3.5
3	2.0	0.6	–	1.4	0.9	4.0	0.6	3.5	3.9
4	2.4	0.8	–	1.6	1.0	5.0	0.8	4.3	4.6

Ordering data			
For \varnothing	Weight [oz]	Basic version	
		Part No.	Type
1/2, 5/8	1.5	157319	SUA-12/16
3/4	2.8	157320	SUA-20
1	3.0	157321	SUA-25
1-1/4	7.3	157322	SUA-32
1-5/8	11.3	157323	SUA-40
2	15.4	157324	SUA-50
2-1/2	26.8	157325	SUA-63
3	42.0	157326	SUA-80
4	67.0	157327	SUA-100

Note
Do not exceed the maximum overall stroke length listed when combining cylinders and swivel flanges.

For \varnothing	Max. stroke length [in]
1/2	2
5/8	2
3/4	2
1	2
1-1/4	4

For \varnothing	Max. stroke length [in]
40	4
50	4
63	4
80	6
100	6

Dimensions are in inches, unless otherwise noted.

Compact cylinders ADVU - Inch Series

Accessories

Swivel flange SNC-125 for piston \varnothing 5 inch

Material:
Wrought aluminum alloy

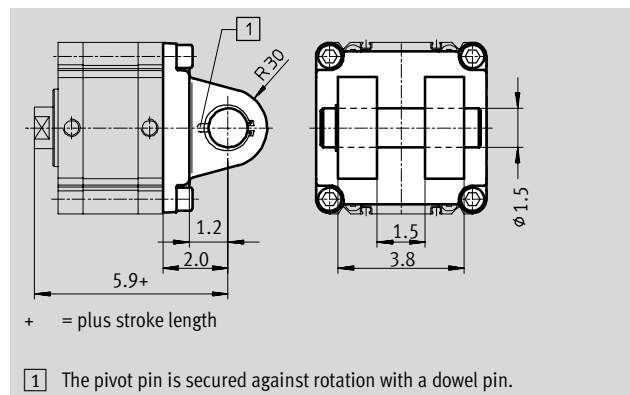

Ordering data			
For \varnothing	CRC ¹⁾	Weight [oz]	Basic version
			Part No. Type
5	2	6.3	174389 SNC-125

1) Corrosion resistance class 2 according to Festo standard 940 070
Components with moderate corrosion resistance for use in normal industrial environments subjected to contact with coolants or lubricating agents.

Swivel flange SNCB-125 for piston \varnothing 5 inch

Material:
SNCB-125: Wrought aluminum alloy
Free of copper, PTFE and silicone

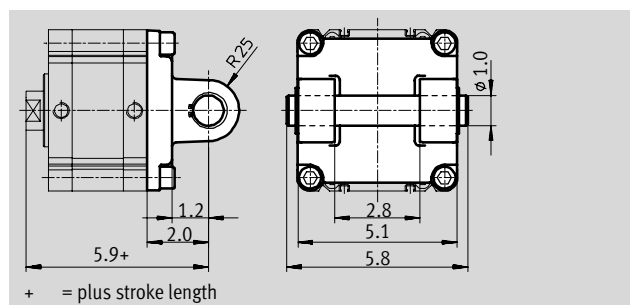

Ordering data			
For \varnothing	Weight	Basic version	
[in]	[oz]	Part No.	Type
5	63.0	174396	SNCB-125

Dimensions are in inches, unless otherwise noted.

Compact cylinders ADVU - Inch Series

Accessories



Swivel flange SNCS-125 for piston \varnothing 5 inch

Material:
Wrought aluminum alloy

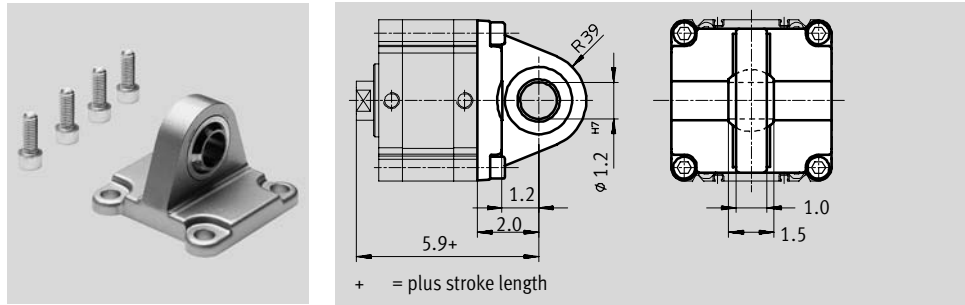

Ordering data			
For \varnothing	Weight [oz]	Basic version	
		Part No.	Type
5	49.7	174403	SNCS-125

Swivel flange SNCL-125 for piston \varnothing 5 inch

Material:
Wrought aluminum alloy

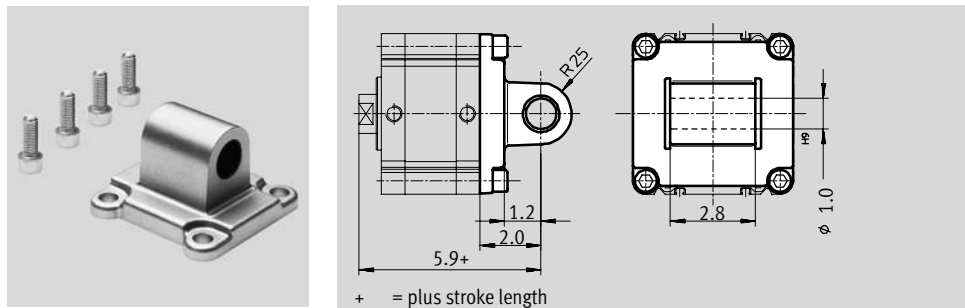

Ordering data			
For \varnothing	Weight [g]	Basic version	
		Part No.	Type
5	43.9	174410	SNCL-125

Dimensions are in inches, unless otherwise noted.

Compact cylinders ADVU - Inch Series

Accessories

Trunnion flange ZNCF-125 for piston \varnothing 5 inch

Material:
High-alloy stainless steel
Free of copper, PTFE and silicone

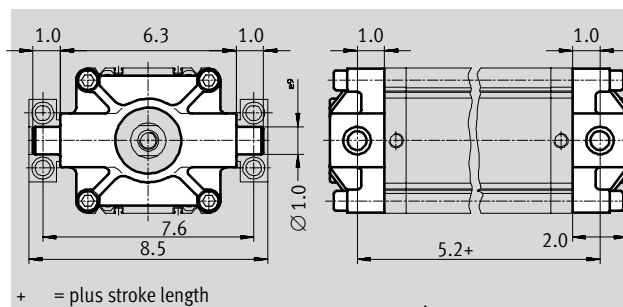

Ordering data			
For \varnothing	Weight [oz]	Basic version	
		Part No.	Type
5	123.1	174417	ZNCF-125

Trunnion mounting kit ZNCM-125 for piston \varnothing 5 inch

Material:
Tempered steel

Note

The trunnion mounting kit can be attached to the cylinder profile barrel at any position.

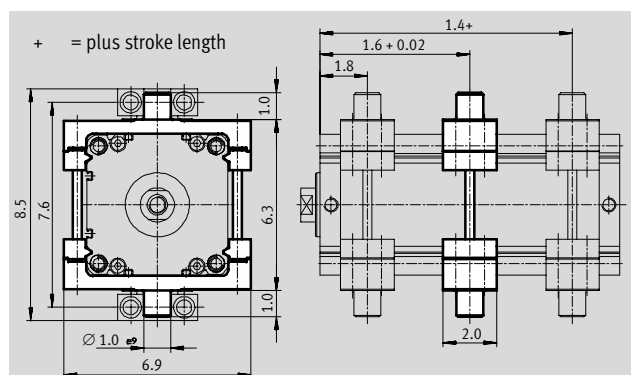

Ordering data				
For \varnothing	CRC ¹⁾	Weight [oz]	Basic version	
			Part No.	Type
5	2	103.7	163531	ZNCM-125

1) Corrosion resistance class 2 according to Festo standard 940 070
Components with moderate corrosion resistance for use in normal industrial environments subjected to contact with coolants or lubricating agents.

Dimensions are in inches, unless otherwise noted.

Compact cylinders ADVU - Inch Series

Accessories

FESTO

Adapter kit DPVU

for piston \varnothing 1/2 ... 4 inch

Material:
Aluminum
Free of copper, PTFE and silicone

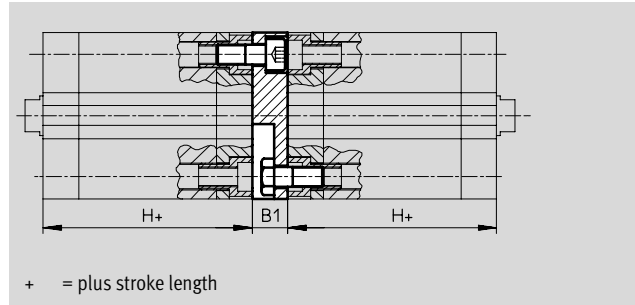

Adapter kit DPNC

for piston \varnothing 5 inch

Material:
Flange: Wrought aluminum alloy
Threaded pins, hex nuts: Galvanized steel

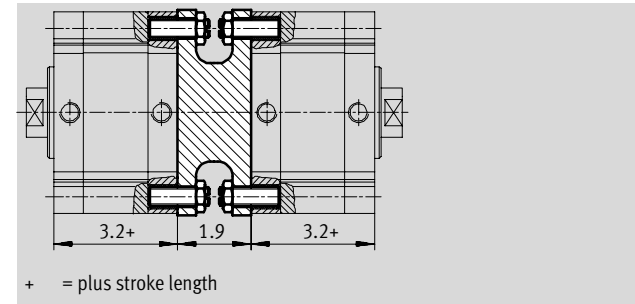
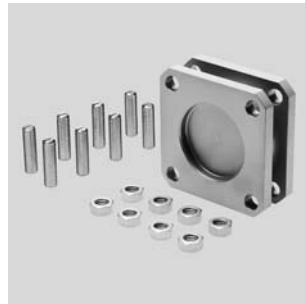

Dimensions and ordering data							
For \varnothing	B1	H	Max. overall stroke length [in]	CRC ¹⁾	Weight [oz]	Part No.	Type
1/2, 5/8	0.5	1.5	15.7	2	0.78	161194	DPVU-12/16
3/4	0.5	1.5	15.7	2	1.27	161195	DPVU-20
1	0.5	1.6	15.7	2	1.55	161196	DPVU-25
1-1/4	0.6	1.8	23.6	2	3.17	161197	DPVU-32
1-5/8	0.6	1.8	23.6	2	4.83	161198	DPVU-40
2	0.6	1.8	23.6	2	6.24	161199	DPVU-50
2-1/2	0.6	2.0	23.6	2	10.86	161200	DPVU-63
3	0.6	2.2	31.5	2	17.46	161201	DPVU-80
4	0.8	2.6	31.5	2	30.30	161202	DPVU-100
5	1.9	3.2	39.4		56.44	174424	DPNC-125

Note

Do not exceed the maximum overall stroke length listed when combining cylinders and the adapter kit.

1) Corrosion resistance class 2 according to Festo standard 940 070
Components with moderate corrosion resistance for use in normal industrial environments subjected to contact with coolants or lubricating agents.

Connecting two cylinders with identical piston \varnothing as a 3 or 4-position cylinder

A 3 or 4-position cylinder consists of two separate cylinders whose piston rods advance in opposing directions.

Depending upon actuation and stroke pattern, this type of cylinder can assume up to four positions. In each

case the cylinder is driven precisely against a stop. If one end of the piston rod is fixed, the cylinder barrel

executes the movement. The cylinder must be connected with flexible line connections.

Implementing 3 positions

Two cylinders with identical stroke length must be connected to accomplish this.

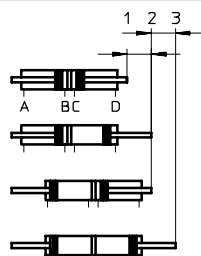

Implementing 4 positions

Two cylinders with different stroke lengths must be connected to accomplish this.

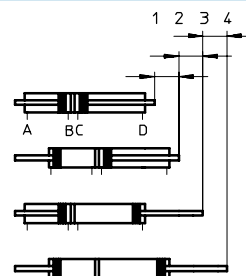



Dimensions are in inches, unless otherwise noted.

Compact cylinders ADVU - Inch Series

Accessories

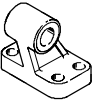
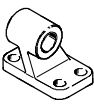
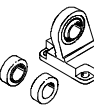
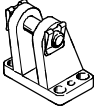
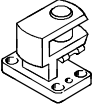
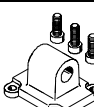

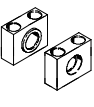
FESTO

Ordering data – Mounting attachments				Ordering data – Mounting attachments			
Designation	For Ø [in]	Part No.	Type	Designation	For Ø [in]	Part No.	Type
Clevis foot LBN				Clevis foot LNG			
	1/2	6058	LBN-12/16		1-1/4	33890	LNG-32
	5/8	6058	LBN-12/16		5/8	33891	LNG-40
	3/4	6059	LBN-20/25		2	33892	LNG-50
	1	6059	LBN-20/25		2-1/2	33893	LNG-63
Clevis foot LN				Clevis foot LSN			
	1-1/4	5147	LN-32		1-1/4	5561	LSN-32
	1-5/8	5148	LN-40		1-5/3	5562	LSN-40
	2	5149	LN-50		2	5563	LSN-50
	2-1/2	5150	LN-63		2-1/2	5564	LSN-63
	3	5151	LN-80		3	5565	LSN-80
	4	5152	LN-100		4	5566	LSN-100
5	9036	LN-125	5	6987	LSN-125		
Clevis foot LBG				Clevis foot, lateral LQG			
	3/4, 1, 1-1/4, 1-5/8	31761	LBG-32		3/4, 1, 1-1/4, 1-5/8	31768	LQG-32
	2, 2-1/2	31762	LBG-40		2,2-1/2	31769	LQG-40
	3	31763	LBG-50		3	31770	LQG-50
		31764	LBG-63			31771	LQG-63
	4	31765	LBG-80		4	31772	LQG-80
		31766	LBG-100			31773	LQG-100
5	31767	LBG-125	5	31774	LQG-125		
Swivel flange SNCL				Clevis foot LSNSG			
	1-1/4	174404	SNCL-32		5	31753	LSNSG-125
	1-5/8	174405	SNCL-40				
	2	174406	SNCL-50				
	2-1/2	174407	SNCL-63				
	3	174408	SNCL-80				
4	174409	SNCL-100					
5	174410	SNCL-125					
				Trunnion support LNZG			
					5	32962	LNZG-100/125

Compact cylinders ADVU - Inch Series

Accessories

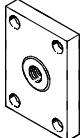

FESTO

Ordering data – Piston rod attachments				Ordering data – Piston rod attachments			
Designation	For Ø [in]	Part No.	Type	Designation	For Ø [in]	Part No.	Type
Rod eye SGS				Self-aligning rod coupler FK			
	1/2	532694	SGS-10-32		1/2	-	
	5/8						
	3/4	532695	SGS-5/16-24		3/4		
	1	532696	SGS-3/8-24		1	36129	KSZ-3/8-24-UNF
	1-1/4	532696	SGS-3/8-24		1-1/4	36129	KSZ-3/8-24-UNF
	1-5/8	532697	SGS-1/2-20		1-5/8	36130	KSZ-1/2-20-UNF
	2	532698	SGS-5/8-18		2	36131	KSZ-5/8-18-UNF
	2-1/2						
	3	532699	SGS-3/4-16		3	36132	KSZ-3/4-16-UNF
	4				4		
5	532700	SGS-1-12	5	-			
Rod clevis SG				Coupling piece KSZ			
	1/2	546552	SG-UNF10-32-B		1/2	532703	FK-10-32
	5/8						
	3/4	546574	SG-UNF5/16-24-B		3/4	532704	FK-5/16-24
	1	546540	SG-UNF3/8-24-B		1	532705	FK-3/8-24
	1-1/4				1-1/4	532705	FK-3/8-24
	1-5/8	546545	SG-UNF1/2-20-B		1-5/8	532706	FK-1/2-20
	2	546575	SG-UNF5/8-18-B		2	532707	FK-5/8-18
	2-1/2						
	3	546576	SG-UNF3/4-16-B		3	532708	FK-3/4-16
	4				4		
5	-		5	532709	FK-1-12		

Compact cylinders ADVU - Inch Series

Accessories



FESTO



Ordering data – One-way flow control valves				
	Connection		Part No.	Type
	Thread	For tubing OD		
For exhaust air				
	10-32 UNF	5/32	165008	GRLA-10-32-UNF-QS-5/32-U
		1/4	192753	GRLA-10-32-UNF-QS-1/4-U
	1/8" NPT	5/32	165009	GRLA-1/8-NPT-QS-5/32-U
		3/16	190941	GRLA-1/8-NPT-QS-3/16-U
		1/4	165010	GRLA-1/8-NPT-QS-1/4-U
		5/16	165013	GRLA-1/8-NPT-QS-5/16-U
	1/4" NPT	3/16	190944	GRLA-1/4-NPT-QS-3/16-U
		1/4	165011	GRLA-1/4-NPT-QS-1/4-U
		5/16	165014	GRLA-1/4-NPT-QS-5/16-U
		3/8	190947	GRLA-1/4-NPT-QS-3/8-U
For supply air				
	10-32-UNF	-	151576	GRLZ-10-UNF-B
		-	151579	GRLZ-10-UNF-RS-B
		3/16	151577	GRLZ-10-UNF-3/16-B
		1/4	151578	GRLZ-10-UNF-1/4-B
	1/8" NPT	-	151561	GRLZ-1/8-NPT-B
		-	151564	GRLZ-1/8-NPT-RS-B
		1/4	151562	GRLZ-1/8-NPT-1/4-B
		3/8	151563	GRLZ-1/8-NPT-3/8-B





Compact cylinders ADVU - Inch Series

Accessories

FESTO

Ordering data – Proximity sensors for slot type 8, magneto-resistive									
	Assembly	Switch output	Electrical connection			Cable length [ft]	Part No.	Type	
			Cable	Plug M8	Plug M12				
NO contact									
	Insertable from above	PNP	3-wire	–	–	8.2	525898	SMT-8F-PS-24V-K2.5-OE	
		NPN		–	–		525909	SMT-8F-NS-24V-K2.5-OE	
		–	2-wire	–	–	8.2	525908	SMT-8F-ZS-24V-K2.5-OE	
		PNP		–	3-pin		–	525899	SMT-8F-PS-24V-K0.3-M8D
		NPN		–			–	525910	SMT-8F-NS-24V-K0.3-M8D
PNP	–	–	3-pin	1.0	525900	SMT-8F-PS-24V-K0.3-M12			
	Insertable from end, flush with the cylinder profile	PNP	3-wire	–	–	8.2	175436	SMT-8-PS-K-LED-24-B	
		–	–	3-pin	–	1.0	175484	SMT-8-PS-S-LED-24-B	
NC contact									
	Insertable from above	PNP	3-wire	–	–	24.6	525911	SMT-8F-PO-24V-K7.5-OE	

Ordering data – Proximity sensors for slot type 8, magnetic reed						
	Assembly	Electrical connection		Cable length [ft]	Part No.	Type
		Cable	Plug M8			
NO contact						
	Insertable from above	3-wire	–	8.2	525895	SME-8F-DS-24V-K2.5-OE
			–		16.4	525897
		2-wire	–	8.2	525907	SME-8F-ZS-24V-K2.5-OE
			–		3-pin	1.0
	Insertable from end, flush with the cylinder profile	3-wire	–	8.2	150855	SME-8-K-LED-24
		–	3-pin	1.0	150857	SME-8-S-LED-24
NC contact						
	Insertable from above	3-wire	–	24.6	525906	SME-8F-DO-24V-K7.5-OE

Ordering data – Plug sockets							
	Assembly	Switch output		Connection	Cable length [ft]	Part No.	Type
		PNP	NPN				
Straight socket							
	M8 locknut	■	■	3-pin	8.2	159420	SIM-M8-3GD-2.5-PU
		■	■		16.4	159421	SIM-M8-3GD-5-PU
	M12 locknut	■	■	3-pin	8.2	159428	SIM-M12-3GD-2.5-PU
		■	■		16.4	159429	SIM-M12-3GD-5-PU
Angled socket							
	M8 locknut	■	■	3-pin	8.2	159422	SIM-M8-3WD-2.5-PU
		■	■		16.4	159423	SIM-M8-3WD-5-PU
	M12 locknut	■	■	3-pin	8.2	159430	SIM-M12-3WD-2.5-PU
		■	■		16.4	159431	SIM-M12-3WD-5-PU

Ordering data – Slot cover for slot type 8			
	Assembly	Length [ft]	Part No. Type
	Insertable from above	2x 1.6	151680 ABP-5-S