



- Precise and rigid guide
- Freely programmable with respect to position, speed and acceleration
- High flexibility
- Motor controller SFC-DC:



Mini slides SLTE, electric

Key features



Range of applications

The electric mini slide SLTE is ideal for use in automation applications where controlled end-position cushioning (gentle stopping), constant travel speed and positioning capability are important factors.

The SLTE has the same interfaces on the yoke, slide and underneath the housing as the pneumatic SLT. It is also fully compatible with the modular handling and assembly system and SLT adapter kits.

Special features

- Precise and rigid guide
- Freely positionable
- Fast positioning times
- Through-holes from above and below
- Sensors can be integrated
- Gentle starting and stopping
- Working loads up to 4 kg
- Constant travel speeds of 2 ... 200 mm/s

Everything from a single source

Motor controller
SFC-DC
→ 1 / 6.1-57

Mini slide
SLTE
→ 1 / 6.1-47

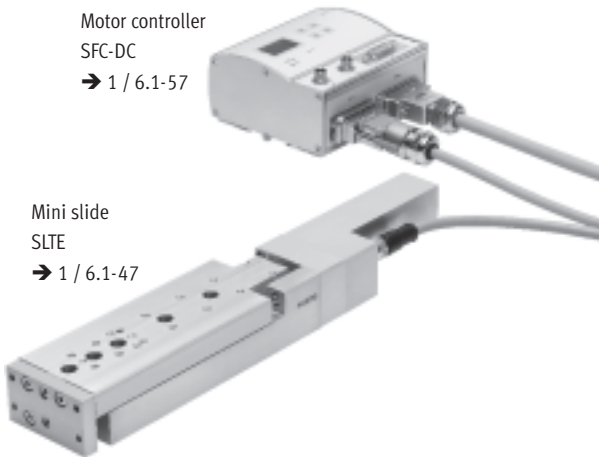

The mini slide SLTE and motor controller SFC form one unit.

- Thanks to the protection class IP54, the SFC can be mounted close to the SLTE, either:
 - with centre supports
 - on an H-rail
- Only one cable required between SLTE and SFC
- Motor controller SFC available with or without control panel
- Easy control with
 - I/O interface
 - Profibus
 - CANopen

Parameterisation possible via

- Control panel:
 - Suitable for simple position sequences
- Configuration package FCT (Festo configuration tool):
 - Parameterisation via RS 232 interface
 - Windows-based PC user interface (Festo configuration tool)



The technology in detail

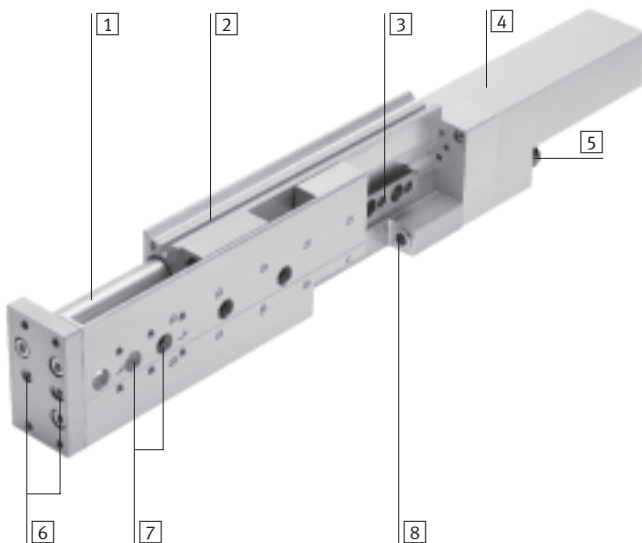

- 1 Drive rod
- 2 Slot for reference switch
- 3 Roller bearing guide
- 4 Drive assembly consisting of DC motor with displacement encoder
- 5 Electrical connection
- 6 Threaded holes and through-holes with centring hole for attaching the working load
- 7 Threaded holes and through-holes with centring hole for attaching the SLTE
- 8 Fixed stop with integrated rubber buffer

Mini slides SLTE, electric

Key features

FESTO

Comparison between electric mini slide SLTE and pneumatic mini slide SLT

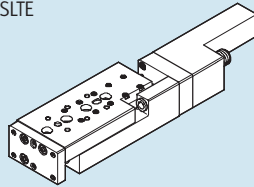
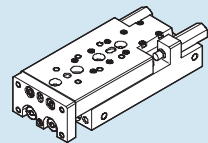
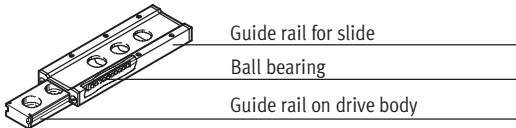
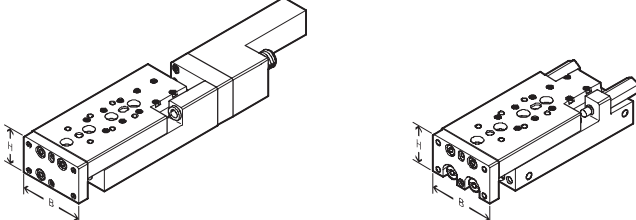
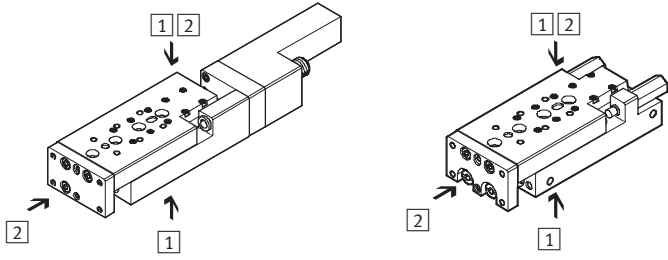
	<p>Electrical: SLTE</p> 	<p>Pneumatic: SLT</p> 												
<p>Advantages</p>														
	<ul style="list-style-type: none"> • Gentle starting and stopping • Constant and precise speed (2 ... 200 mm/s) • Flexible positioning without mechanical devices • Programmable drive profile 	<ul style="list-style-type: none"> • High feed force • High speed • Fast positioning time • Compact length 												
<p>Guide</p>														
<ul style="list-style-type: none"> • Preloaded, backlash-free, precise and rigid ball bearing cage guide • High torque and load absorption 	 <p>Guide rail for slide</p> <p>Ball bearing</p> <p>Guide rail on drive body</p>													
<p>Dimensions</p>														
<ul style="list-style-type: none"> • Identical width and height dimensions <table border="1" data-bbox="148 1115 606 1209"> <thead> <tr> <th>Type</th> <th>Width (W)</th> <th>x</th> <th>Height (H)</th> </tr> </thead> <tbody> <tr> <td>SLT(E)-10</td> <td>50</td> <td>x</td> <td>30 mm</td> </tr> <tr> <td>SLT(E)-16</td> <td>66</td> <td>x</td> <td>40 mm</td> </tr> </tbody> </table>	Type	Width (W)	x	Height (H)	SLT(E)-10	50	x	30 mm	SLT(E)-16	66	x	40 mm		
Type	Width (W)	x	Height (H)											
SLT(E)-10	50	x	30 mm											
SLT(E)-16	66	x	40 mm											
<p>Interfaces</p>														
<ul style="list-style-type: none"> • Identical mounting and attachment options <p>1 Attachment surfaces: Direct mounting using threaded holes and through-holes</p> <p>2 Mounting surfaces: Direct mounting of loads and devices (e.g. SLT: semi-rotary drives and grippers) via threaded holes in the slide and the yoke plate</p>														
<p>Technical data</p>														
<p>Piston Ø</p>	<p>[mm] 10, 16</p>	<p>6 ... 25</p>												
<p>Stroke</p>	<p>[mm] 50 ... 150</p>	<p>10 ... 200</p>												
<p>Max. speed</p>	<p>[m/s] 0.2</p>	<p>0.8</p>												
<p>Repetition accuracy at end positions</p>	<p>[mm] ±0.1</p>	<p>±0.02</p>												
<p>Intermediate positions</p>	<p>Any</p>	<p>None</p>												

Mini slides SLTE, electric

Key features

System product for handling and assembly technology

Drives with linear guides
Slides

6.1

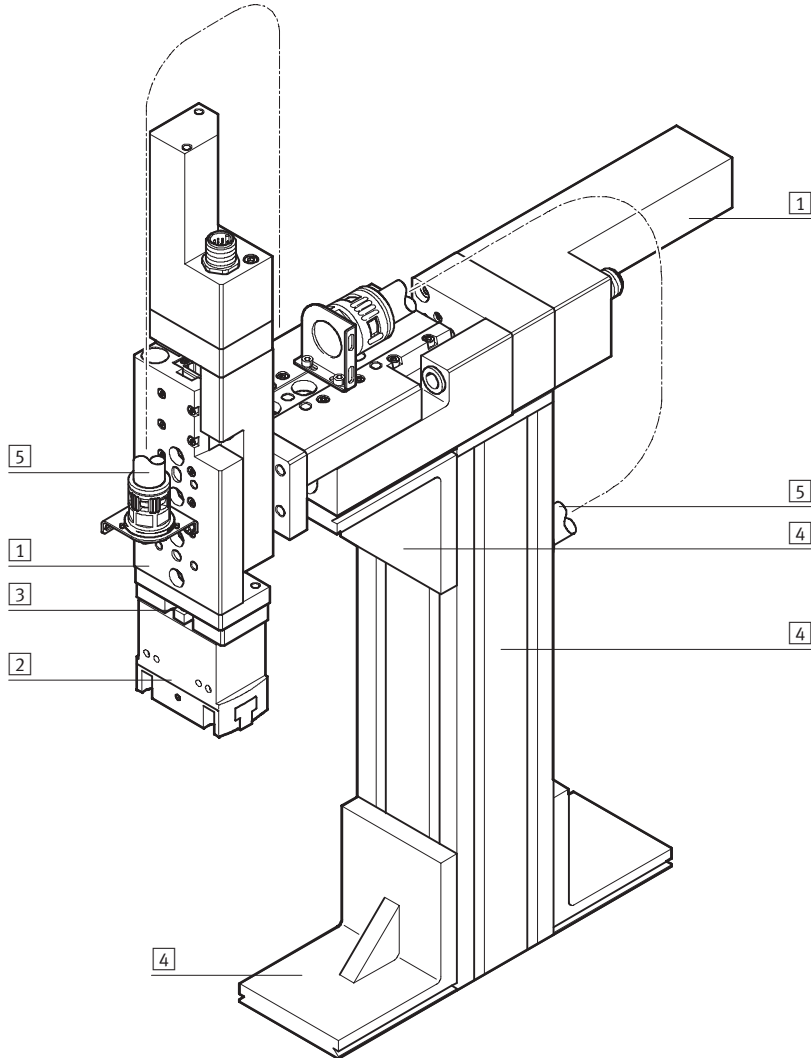

System elements and accessories		
	Brief description	→ Page
1	Axes	Wide range of combinations possible within handling and assembly technology Volume 5
2	Grippers	Wide range of variations possible within handling and assembly technology Volume 1
3	Adapters	For drive/drive and drive/gripper combinations Volume 5
4	Basic mounting components	Profiles and profile connectors as well as profile/drive connectors Volume 5
5	Installation components	For manageable and secure guidance of electrical cables and tubing Volume 5
-	Drive units	Wide range of combinations possible within handling and assembly technology Volume 1

Mini slides SLTE, electric

Peripherals overview

Size 10/16

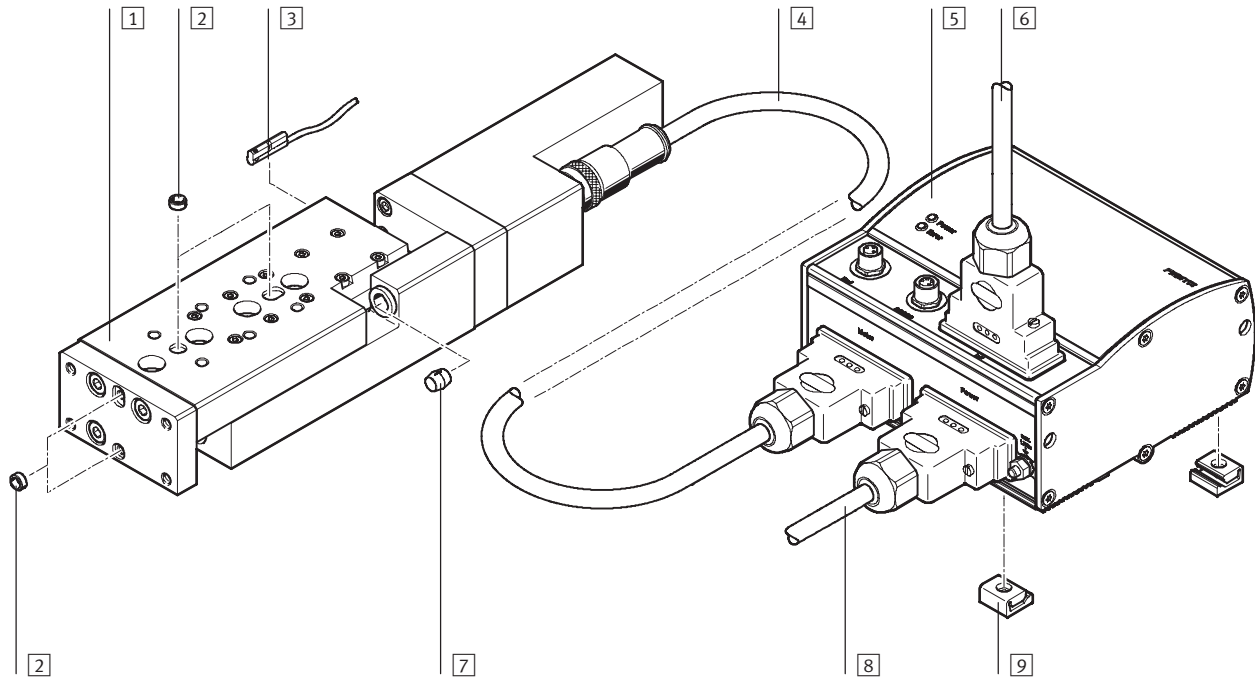

Accessories			
	Brief description	→ Page	
1	Mini slide SLTE	1 / 6.1-47	
2	Centring pin/sleeve ZBS/ZBH	– For centring loads and attachment components – Centring sleeves included in scope of delivery	1 / 6.1-55
3	Proximity sensor SME/SMT-10	For referencing mini slide or for sensing slide position	1 / 6.1-55
4	Motor cable KMTR	Connecting cable between motor and motor controller	1 / 6.1-61
5	Motor controller SFC	For parameterising and positioning mini slide	1 / 6.1-57
6	Control cable KES	For I/O connection to any controller	1 / 6.1-61
6	Plug FBS, FBA	For fieldbus interface: Profibus or CANopen	1 / 6.1-61
7	Buffer	Buffer included in scope of delivery	–
8	Supply cable KPWR	Power supply cable; load and logic power supplies are isolated	1 / 6.1-61
9	Centre supports MUP	– For mounting motor controller – Motor controller can also be mounted on H-rail	1 / 6.1-62

Mini slides SLTE, electric

Type codes

SLTE – 16 – 80 – LS – G04

Type

SLTE	Mini slide
------	------------

Size

Stroke [mm]

Drive spindle/pitch



LS	Lead screw
----	------------

Gearing type

G04	Gear unit ratio $i = 4.4$
-----	---------------------------

Mini slides SLTE, electric

Technical data

-  Size
10 and 16
-  Stroke length
50 ... 150 mm



General technical data			
Size	10	16	
Constructional design	Electromechanical linear axis with lead screw		
Guide	With ball bearings		
Type of mounting	Via through-holes		
	Via female thread		
	Via female thread and centring sleeve		
Stroke [mm]	50, 80	50, 80, 100, 150	
Stroke reserve per end position	with rubber buffer at both ends [mm]	0.5	0.6
	with rubber buffer at one end [mm]	1.2	1.25
Assembly position	Any		
Lead screw pitch [mm]	5	7.5	
Min. travel speed [mm/s]	2		
Max. acceleration [m/s ²]	2.5		
Repetition accuracy [mm]	±0.1		
Reversing backlash [mm]	< 0.1		

Electrical data for motor		
Size	10	16
System resolution of encoder	512 (pulses per rotation)	1,000 (pulses per rotation)
Nominal operating voltage [V DC]	24	
Output [W]	4.5	18

Operating and environmental conditions		
Size	10	16
Ambient temperature [°C]	0 ... +40	
Protection class	IP40	
Fast transients	To EN61000-4-4	
Max. noise level ¹⁾ [dB A]	< 50	< 55
CE symbol (declaration of conformity)	In accordance with EU EMC directive	

1) At maximum permissible speed

Weight [g]							
Size	10			16			
	50	80		50	80	100	150
Product weight	574	737		1,185	1,465	1,714	2,196
Moving load	163	235		296	415	519	729

Mini slides SLTE, electric

Technical data

Materials

Sectional view

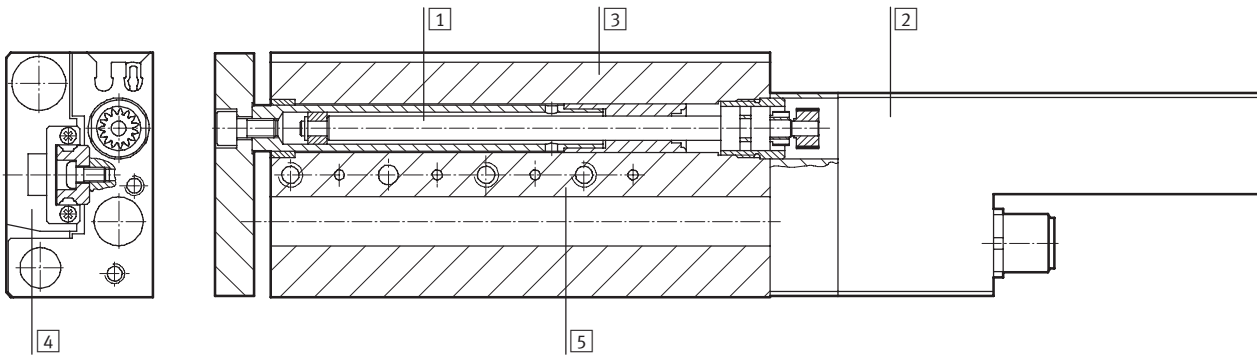

Mini slide

1	Lead screw	High-alloy steel
2	Motor housing	Wrought aluminium alloy, anodised
3	Housing	Wrought aluminium alloy, anodised
4	Slide	Wrought aluminium alloy, anodised
5	Guide	Tempered steel
-	Seals	Thermoplastic rubber, nitrile rubber

Travel speed v as a function of applied load m

Horizontal mounting position

SLTE-10

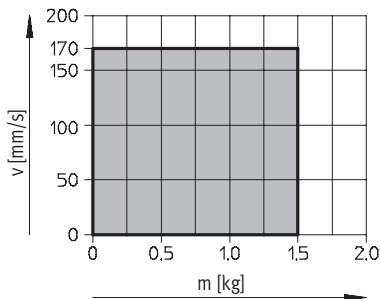

SLTE-16

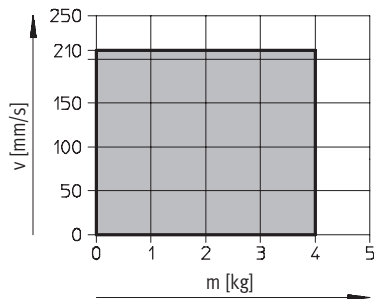

Vertical mounting position

SLTE-10

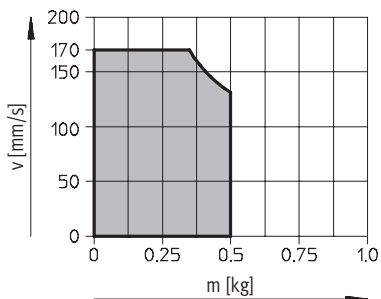

SLTE-16

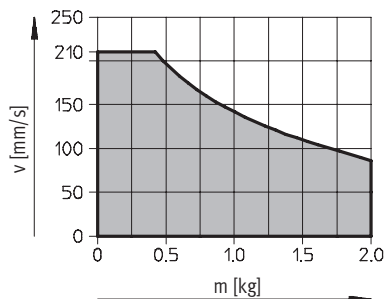

 Permissible operating range

Mini slides SLTE, electric

Technical data

Positioning time t as a function of stroke l

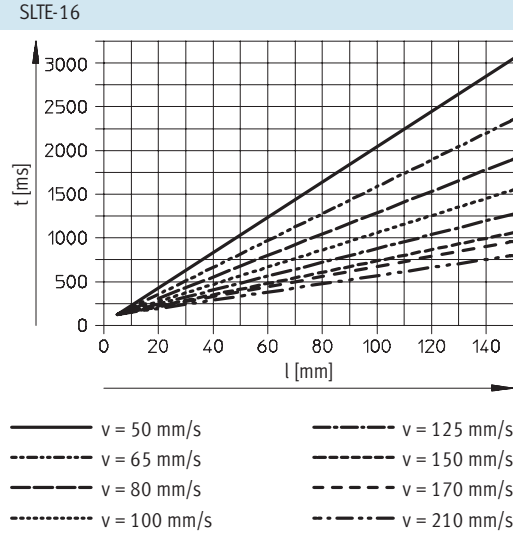
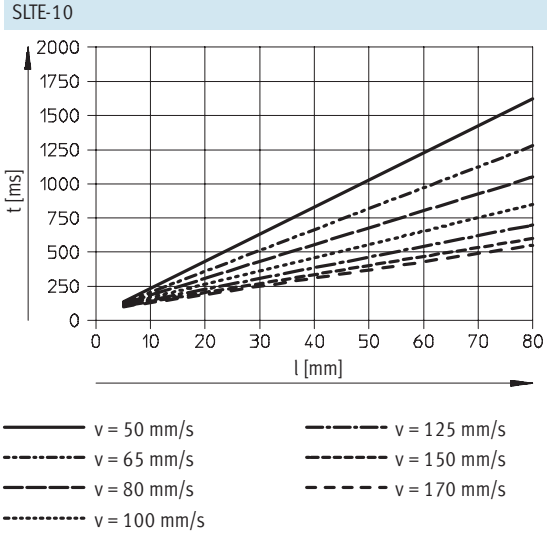

Reference travel

- to fixed stop
- Positive fixed stop
 - To front stop bush (extended)
 - Negative fixed stop
 - To rear stop bush (retracted)

- to proximity sensor
- Position freely selectable

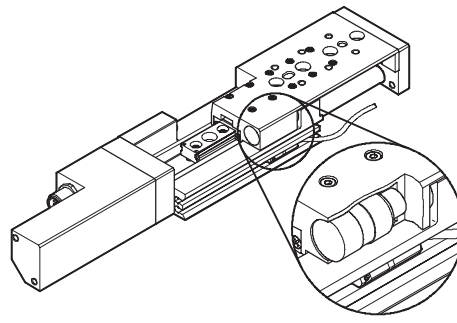
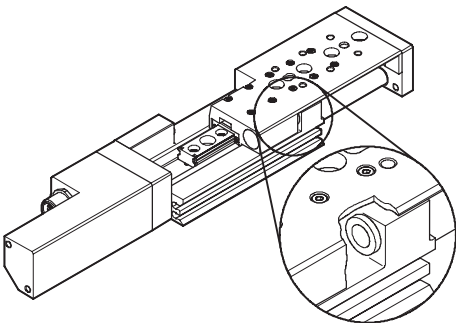

The following applies for reference travel to a fixed stop:

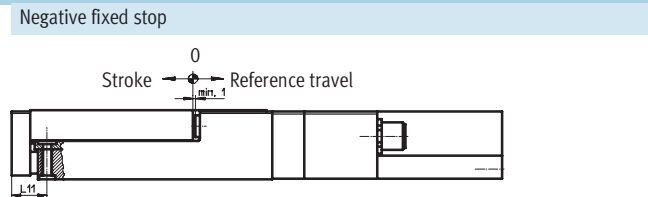
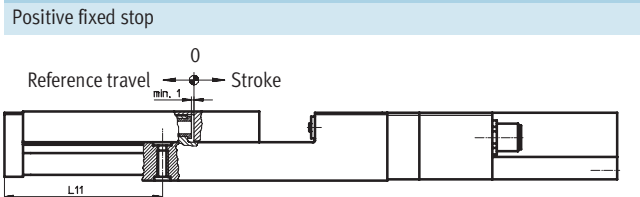

Size	Stroke	L11	
		Positive fixed stop	Negative fixed stop
10	50	67.4 ^{+1.1}	15.6 ^{-1.1}
	80	97.0 ^{+1.1}	15.2 ^{-1.1}
16	50	74.9 ^{+1.1}	23.1 ^{-1.1}
	80	104.1 ^{+1.1}	22.3 ^{-1.1}
	100	124.6 ^{+1.1}	22.8 ^{-1.1}
	150	173.3 ^{+1.1}	21.5 ^{-1.1}

Mini slides SLTE, electric

Technical data

Dynamic characteristic load values

Torques are indicated with reference to the centre of the guide. They must not be exceeded in the dynamic range. Special attention must be paid to the cushioning phase.

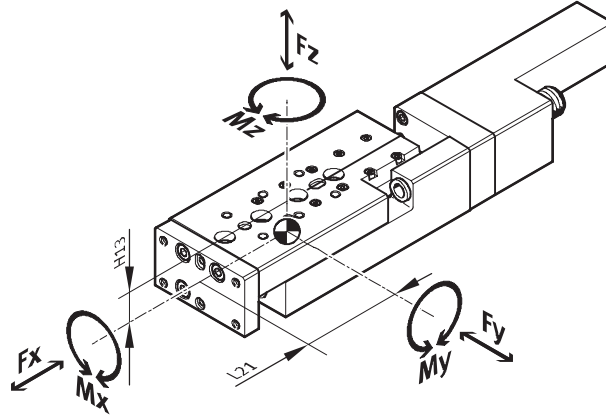

If the drive is subjected to more than two of the indicated forces and torques simultaneously, the following equation must be satisfied in addition to the indicated maximum loads:

$$\frac{|F_y|}{F_{y_{max}}} + \frac{|F_z|}{F_{z_{max}}} + \frac{|M_x|}{M_{x_{max}}} + \frac{|M_y|}{M_{y_{max}}} + \frac{|M_z|}{M_{z_{max}}} \leq 1$$

Position of the guide centre



+ plus stroke length

Permissible forces and torques						Geometric characteristics	
Size	Stroke	F _y _{max} [N]	F _z _{max} [N]	M _x _{max} , M _y _{max} [Nm]	M _z _{max} [Nm]	H13 [mm]	L21 [mm]
10							
	50	390	390	3.1	1.4	13	33.5
	80	410	410	4.3	1.5		41
16							
	50	510	510	4.6	2.8	16	35
	80	520	520	6.0	2.8		41.5
	100	600	600	9.1	3.2		51.5
	150	660	960	12.6	3.5		66.5

Mini slides SLTE, electric

Technical data

Calculation example

Given:

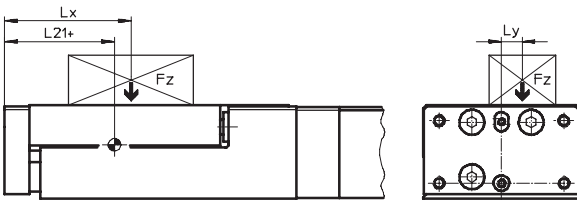

Mini slide	= SLTE-10
Stroke length	= 80 mm
Lever arm L_x	= 50 mm
Lever arm L_y	= 30 mm
Weight F_z	= 0.8 kg
Acceleration a	= 0 m/s ²

To be found:

 F_y, F_z, M_x, M_y, M_z
 and verification of function with
 combined load

Solution:
 $L_{21} = 41 \text{ mm}$ from table

 $F_y = 0 \text{ N}$
 $F_z = m \times g$
 $= 0.8 \text{ kg} \times 9.81 \text{ m/s}^2 = 7.848 \text{ N}$
 $M_x = m \times g \times L_y$
 $= 0.8 \text{ kg} \times 9.81 \text{ m/s}^2 \times 30 \text{ mm} = 0.236 \text{ Nm}$
 $M_y = m \times g \times [(L_{21} + \text{stroke}) - L_x]$
 $= 0.8 \text{ kg} \times 9.81 \text{ m/s}^2 [(41 \text{ mm} + 80 \text{ mm}) - 50 \text{ mm}] = 0.557 \text{ Nm}$
 $M_z = 0 \text{ Nm}$

Combined load:

$$\frac{|F_y|}{F_{y_{\max}}} + \frac{|F_z|}{F_{z_{\max}}} + \frac{|M_x|}{M_{x_{\max}}} + \frac{|M_y|}{M_{y_{\max}}} + \frac{|M_z|}{M_{z_{\max}}}$$

$$= 0 + \frac{7.848 \text{ N}}{410 \text{ N}} + \frac{0.2366 \text{ Nm}}{4.3 \text{ Nm}} + \frac{0.557 \text{ Nm}}{1.5 \text{ Nm}} + 0 = 0.445 \leq 1$$

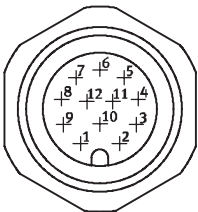
Pin allocation of connection plug

Plug M12		
Pin	Connection	Function
1	Motor +	Motor conductor
2	Motor -	Motor conductor
3	A	Encoder signal RS 485
4	A/	Encoder signal RS 485
5	B	Encoder signal RS 485
6	B/	Encoder signal RS 485
7	I	Encoder signal RS 485
8	I/	Encoder signal RS 485
9	+5 V DC	Signal supply
10	0 V	Signal ground
11	-	-
12	-	-

Mini slides SLTE, electric

Technical data

Dimensions

Download CAD data → www.festo.com/en/engineering

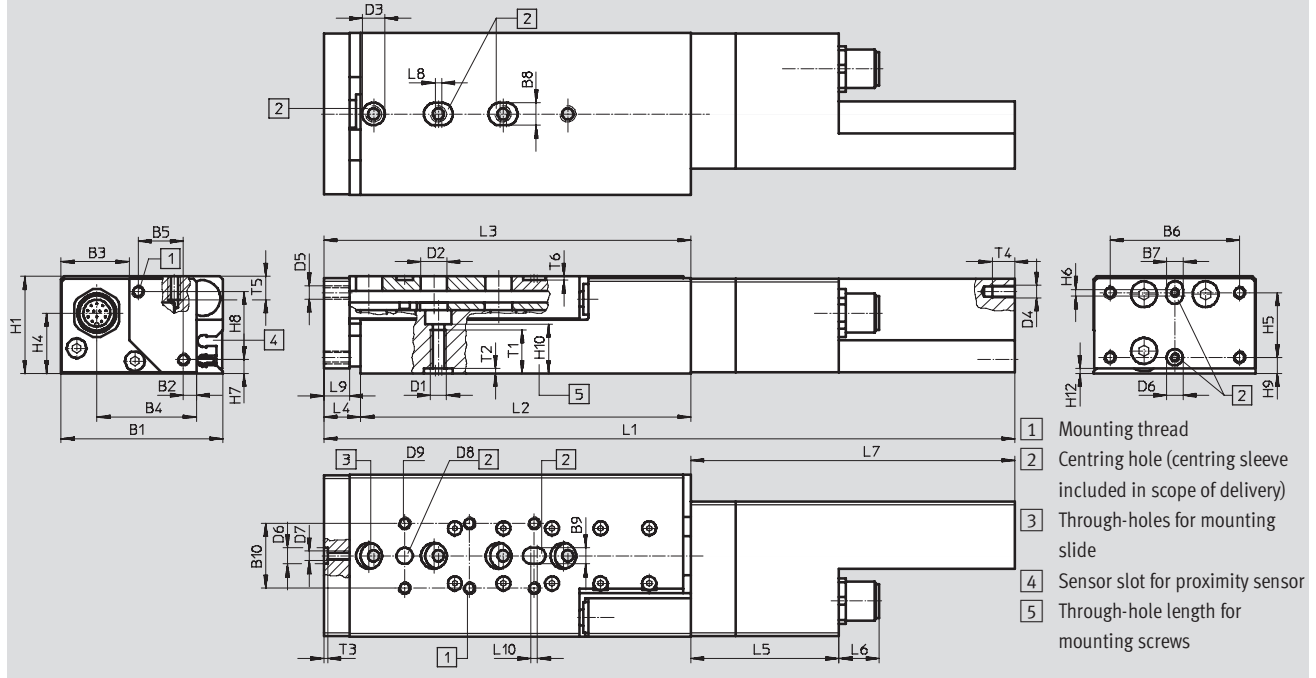

Size	B1	B2	B3	B4	B5	B6	B7	B8	B9	B10	D1	D2	D3	D4
		±0.3	±0.3				H7	H7	H7			∅	∅	
10	50	30.8	20.8	4	14	40	5	5	5	20	M5	8	7	M4
16	66	45.7	24.3	4.2	25	55	7	9	5	20	M6	10	9	M4

Size	D5	D6	D7	D8	D9	H1	H4	H5	H6	H7	H8	H9	H10	H12
		∅ H7		∅ H7										
10	M4	5	M3	5	M4	30	18.4	20	2	4	21	5	15	1.5
16	M5	7	M4	5	M5	40	25.8	20	2	4.5	30	13	20	1.5

Size	Stroke [mm]	L1 ±1.5		L2	L3 ±1		L4 ±1	
		1)	2)		1)	2)	1)	2)
10	50	212	213	102	112	113	10	11.1
	80	262	263	152	162	163	9.6	10.7
16	50	262.5	263.5	100	112.5	113.5	12.5	13.5
	80	307.5	308.5	146	158	159	11.7	12.7
	100	349	350	187	199.5	200.5	12.2	13.2
	150	430.5	431.5	270	281	282	11	12

Size	L5	L6	L7	L8	L9	L10	T1	T2	T3	T4	T5	T6
	±0.5											
10	45.8	12.5	100	2	8	2	12	1.5	1.2	7	8	1.2
16	56.3	12.5	149.7	2	10	1	16	2.1	1.5	7	7	1.2

1) End position at fixed stop
 2) End position at rubber buffer

Mini slides SLTE, electric

Technical data

Hole pattern for mounting thread and centring holes

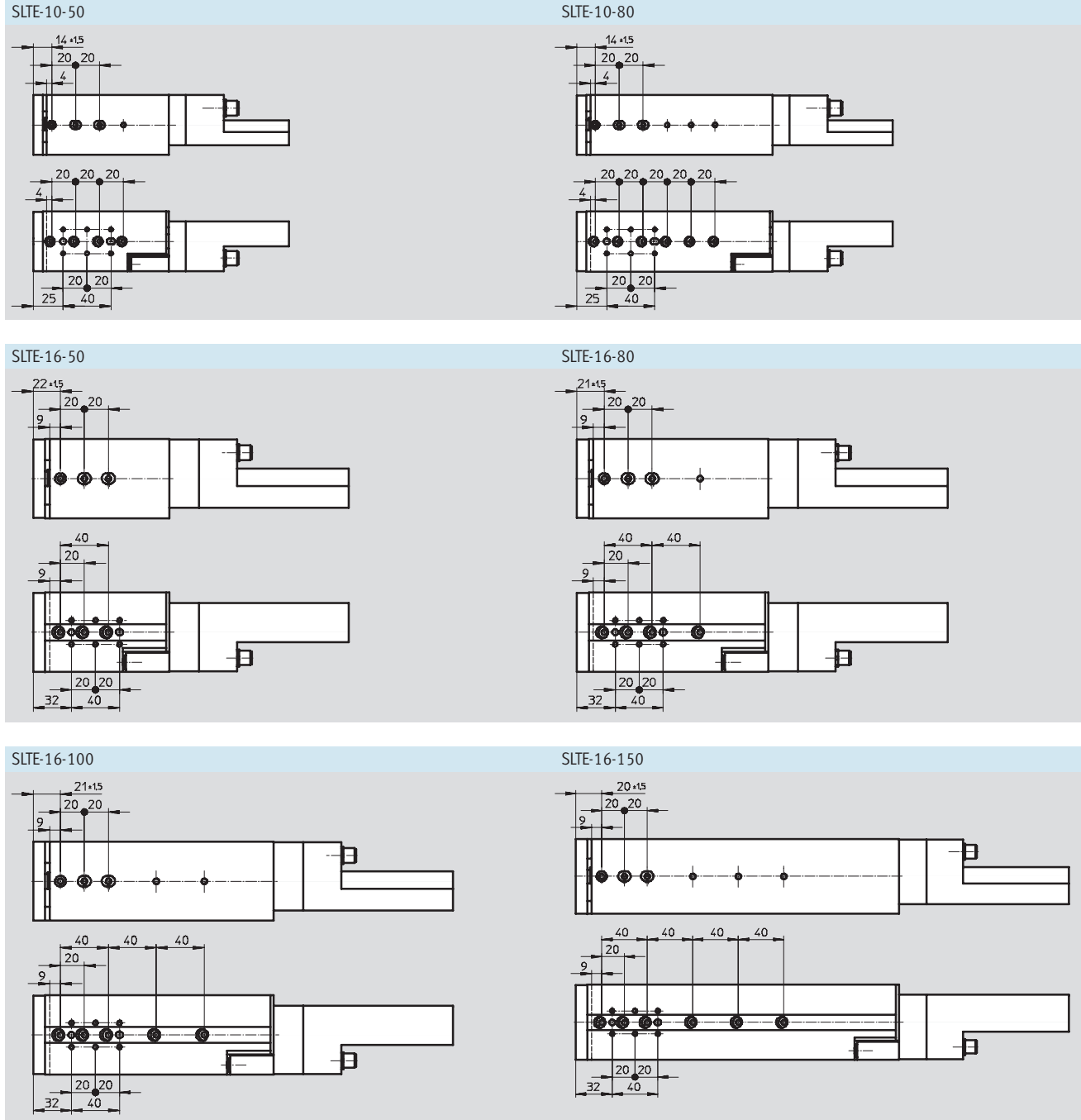

Mini slides SLTE, electric

Technical data

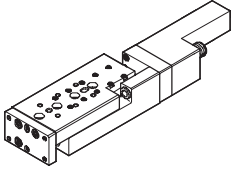
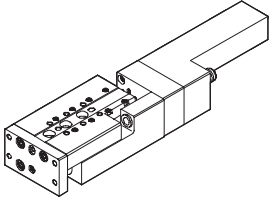
Ordering data			
Size	Brief description	Part No.	Type
10			
	Mini slide	537 447	SLTE-10-50-LS-G04
		537 449	SLTE-10-80-LS-G04
16			
	Mini slide	537 459	SLTE-16-50-LS-G04
		537 461	SLTE-16-80-LS-G04
		537 463	SLTE-16-100-LS-G04
		537 465	SLTE-16-150-LS-G04



Mini slides SLTE, electric



Accessories



FESTO

Ordering data – Centring sleeves ¹⁾				Technical data → 1 / 10.1-18	
Size	10		16		
	Part No.	Type	Part No.	Type	
	Housing	186 717	ZBH-7	150 927	ZBH-9
	Slide	189 652	ZBH-5	189 652	ZBH-5
	Yoke	189 652	ZBH-5	186 717	ZBH-7

1) Scope of delivery: 10 per pack

Ordering data – Proximity switches for C-slot, magneto-resistive					Technical data → www.festo.com/catalogue/sm	
	Type of mounting	Switch output	Electrical connection, connection direction	Cable length [m]	Part No.	Type
N/O contact						
	Insertable in the slot from above, flush with cylinder profile	PNP	Cable, 3-wire, in-line	2,5	525 915	SMT-10F-PS-24V-K2,5L-OE
			Plug M8x1, 3-pin, in-line	0,3	525 916	SMT-10F-PS-24V-K0,3L-M8D
			Plug M8x1, 3-pin, lateral	0,3	526 675	SMT-10F-PS-24V-K0,3Q-M8D
	Insertable in the slot lengthwise	PNP	Plug M8x1, 3-pin, in-line	0,3	173 220	SMT-10-PS-SL-LED-24
			Cable, 3-wire, in-line	2,5	173 218	SMT-10-PS-KL-LED-24

Ordering data – Proximity switches for C-slot, magnetic reed					Technical data → www.festo.com/catalogue/sm	
	Type of mounting	Switch output	Electrical connection, connection direction	Cable length [m]	Part No.	Type
N/O contact						
	Insertable in the slot from above, flush with cylinder profile	Contacting	Plug M8x1, 3-pin, in-line	0,3	525 914	SME-10F-DS-24V-K0,3L-M8D
			Cable, 3-wire, in-line	2,5	525 913	SME-10F-DS-24V-K2,5L-OE
			Cable, 2-wire, in-line	2,5	526 672	SME-10F-ZS-24V-K2,5L-OE
	Insertable in the slot lengthwise	Contacting	Plug M8x1, 3-pin, in-line	0,3	173 212	SME-10-SL-LED-24
			Cable, 3-wire, in-line	2,5	173 210	SME-10-KL-LED-24

Ordering data – Connecting cables				Technical data → www.festo.com/catalogue/nebu	
	Electrical connection, left	Electrical connection, right	Cable length [m]	Part No.	Type
	Straight socket, M8x1, 3-pin	Cable, open end, 3-wire	2,5	541 333	NEBU-M8G3-K-2.5-LE3
			5	541 334	NEBU-M8G3-K-5-LE3
	Angled socket, M8x1, 3-pin	Cable, open end, 3-wire	2,5	541 338	NEBU-M8W3-K-2.5-LE3
			5	541 341	NEBU-M8W3-K-5-LE3

Motor controllers SFC-DC

Type codes

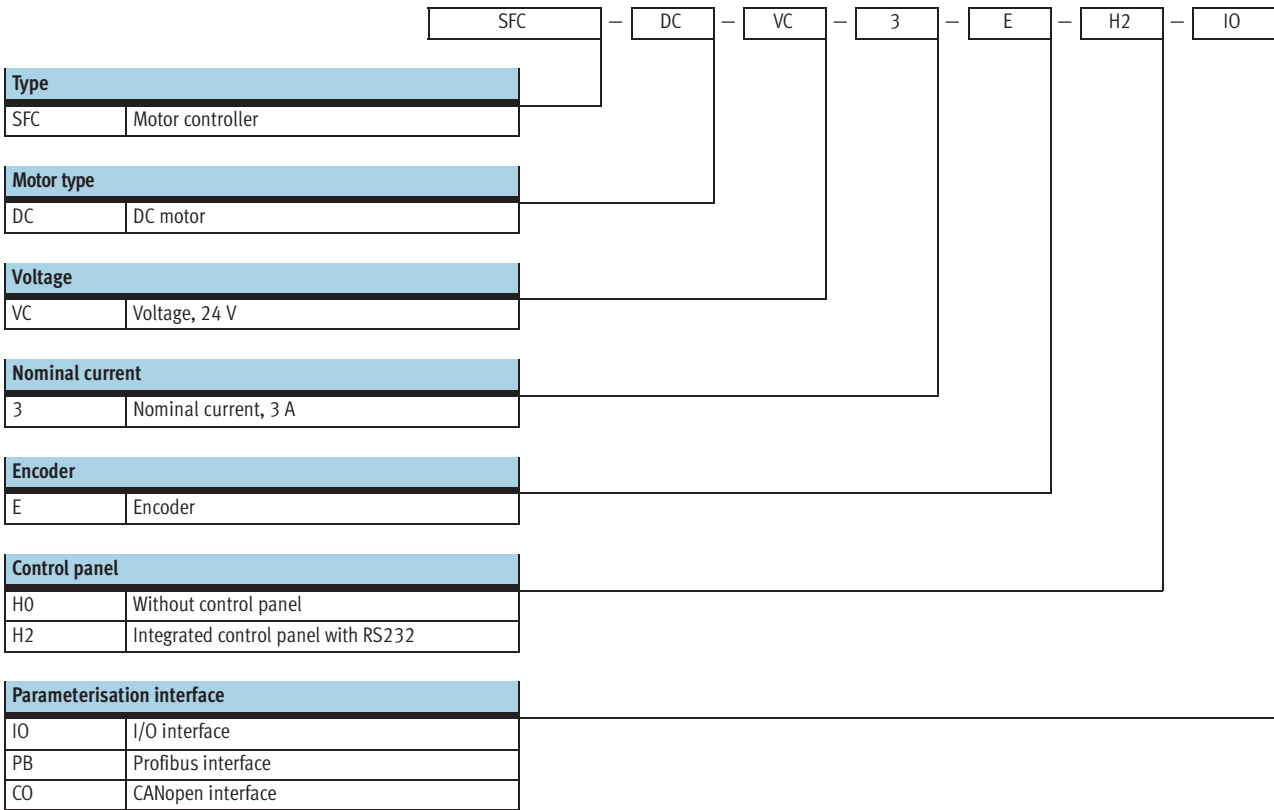

Motor controllers SFC-DC

Technical data

Fieldbus interfaces



General technical data			
Type	SFC-...-IO	SFC-...-PB	SFC-...-CO
Operating mode	Cascade closed-loop controller with – P current regulator		– PI closed-loop speed controller – P position regulator
Position sensor	Encoder		
Encoder input	RS485/RS422, A/B signal with index pulse		
Display (optional)	Four-key interface with full-text display via graphic LCD display (128 x 64 pixels)		
Control elements (optional)	4 keys		
Interface	I/O interface for 31 position sets and homing	Profibus DP	CANopen
Number of digital logic inputs	8	–	–
Number of digital logic outputs	4	–	–
Bus terminating resistor ¹⁾	–	Not integrated in the device	Not integrated in the device
Communication profile	–	DP-V0/V1 / FHPP	DS301; / FHPP
	–	Step7 functional modules	DS301; DSP402
Max. fieldbus baud rate	[Mbit/s] –	12	1
Type of mounting	H-rail, wall or surface bracket		
Product weight	[g] 600		

1) Details of bus terminating resistor → 1 / 6.1-61

Electrical data		
General		
Rated output	[W]	75
Parameterisation interface		RS232; 9600 baud
Load supply		
Nominal voltage	[V DC]	24 ±10%
Nominal current	[A]	3
Peak current	[A]	5
Logic supply		
Nominal voltage	[V DC]	24 ±10%
Nominal current	[A]	0.1
Peak current	[A]	0.8
Max. current per output (digital logic outputs)	[A]	0.5

Motor controllers SFC-DC

Technical data



Drives with linear guides
Slides

6.1

Operating and environmental conditions			
Type	SFC-...-IO	SFC-...-PB	SFC-...-CO
Digital logic outputs	Electrically isolated	-	-
Logic inputs	Electrically isolated	-	-
Specification, logic input	IEC 61131	-	-
Protection class	IP54		
Vibration resistance	To DIN EN 60068-2-6		
Shock resistance	To DIN EN 60068-2-27		
Protective function	I ² t monitoring		
	Current monitoring		
	Voltage failure detection		
	Lag error monitoring		
	Software end position detection		
CE mark (see declaration of conformity)	In accordance with EU EMC directive		
Ambient temperature	[°C]	0 ... +40	
Storage temperature	[°C]	-25 ... +60	
Relative air humidity	[%]	0 ... 95 (non-condensing)	

Pin allocation

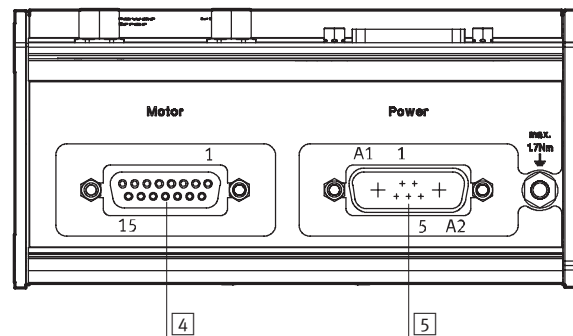
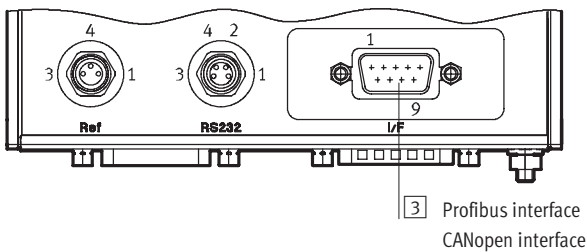
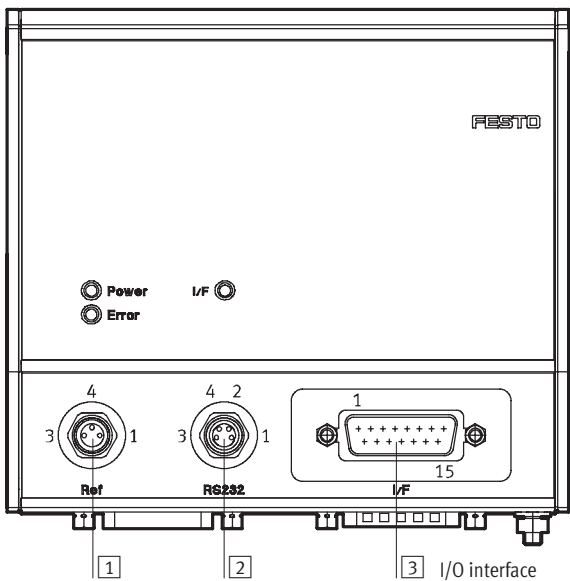

1 Reference switch, 3-pin M8 socket	
Pin	Function
1	24 V
4	Reference input
3	0 V
-	

2 RS 232 interface, 4-pin M8 socket	
Pin	Function
1	0 V
2	Transmitted Data (TxD)
3	Received Data (RxD)
4	-

Motor controllers SFC-DC

Technical data

3 I/O interface, 15-pin Sub-D plug	
Pin	Function
1	24 V (supply for output)
2	Position set coding, bit 1
3	Position set coding, bit 2
4	Position set coding, bit 3
5	Position set coding, bit 4
6	Position set coding, bit 5
7	Stop bit
8	0 V
9	Enable bit
10	Start bit
11	MC
12	Ready
13	Acknowledge
14	Error
15	0 V

3 Profibus interface, 9-pin Sub-D socket	
Pin	Function
1	–
2	–
3	RxD/TxD-P
4	CNTR-P
5	DGND
6	VP
7	–
8	RxD/TxD-N
9	–

3 CANopen interface, 9-pin Sub-D plug	
Pin	Function
1	–
2	CAN_L
3	CAN_GND
4	–
5	CAN_SHLD
6	GND
7	CAN_H
8	–
9	VAN_V+

4 Motor interface, 15-pin Sub-D socket	
Pin	Function
1	VCC logic
2	Encoder channel A
3	Encoder channel A/
4	Encoder channel B
5	Encoder channel B/
6	Encoder channel C
7	Encoder channel C/
8	Logic 0 V
9	0 V
10	0 V
11	0 V
12	Motor +
13	Motor–
14	0 V
15	0 V

5 Power supply, 7-pin plug	
Pin	Function
A1	24 V (load)
A2	0 V (load)
1	24 V (logic)
2	0 V (logic)
3	–
4	PE
5	–

Motor controllers SFC-DC

Technical data

Dimensions

Download CAD data → www.festo.com/en/engineering

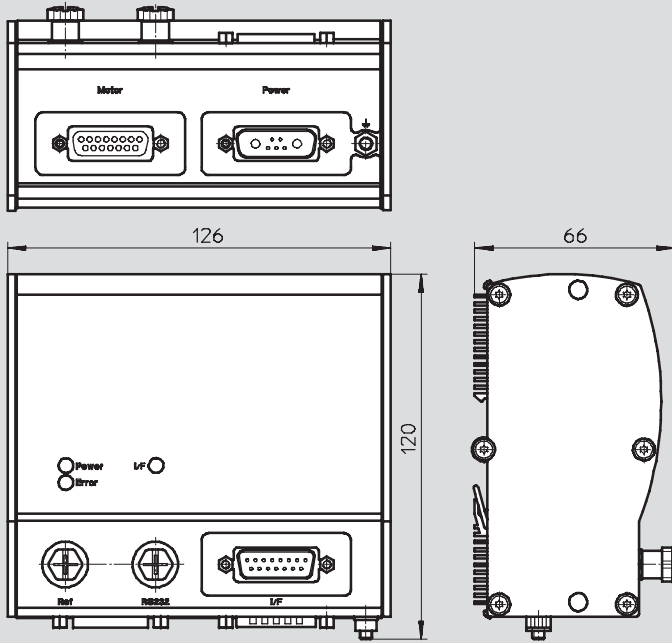

Ordering data

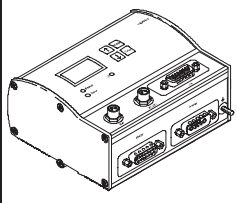
	Brief description	Part No.	Type
	Motor controller with I/O interface		
	Without control panel	538 912	SFC-DC-VC-3-E-H0-IO
	With control panel	538 913	SFC-DC-VC-3-E-H2-IO
	Motor controller with Profibus interface		
	Without control panel	540 366	SFC-DC-VC-3-E-H0-PB
	With control panel	540 367	SFC-DC-VC-3-E-H2-PB
	Motor controller with CANopen interface		
	Without control panel	540 364	SFC-DC-VC-3-E-H0-CO
	With control panel	540 365	SFC-DC-VC-3-E-H2-CO

Motor controllers SFC-DC

Accessories

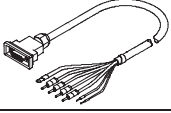
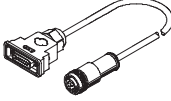
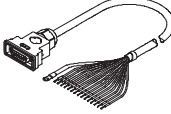
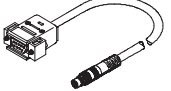
Ordering data – Cables				
	Brief description	Cable length [m]	Part No.	Type
	Supply cable, for connecting load and logic supply	2.5	538 914	KPWR-MC-1-SUB-15HC-2,5
		5	538 915	KPWR-MC-1-SUB-15HC-5
		10	538 916	KPWR-MC-1-SUB-15HC-10
	Motor cable, for connecting motor and controller	2.5	538 917	KMTR-DC-SUB-15-M12-2,5
		5	538 918	KMTR-DC-SUB-15-M12-5
		10	539 316	KMTR-DC-SUB-15-M12-10
	Control cable, for I/O interface to any controller	2.5	538 919	KES-MC-1-SUB-15-2,5
		5	538 920	KES-MC-1-SUB-15-5
		10	538 921	KES-MC-1-SUB-15-10
	Programming cable, for parameterisation and commissioning via RS232 interface using FCT software	2.5	537 926	KDI-MC-M8-SUB-9-2,5

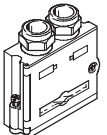
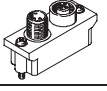
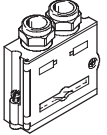
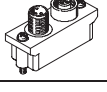
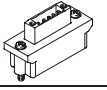
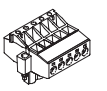
Ordering data – Plugs				
	Brief description	Part No.	Type	
Plug for Profibus				
	<ul style="list-style-type: none"> – 9-pin Sub-D connection – Bus terminating resistor integrated – Position of DIL switch can be read externally – IP65 	532 216	FBS-SUB-9-GS-DP-B	
Bus connection adapter for Profibus				
	<ul style="list-style-type: none"> – 9-pin Sub-D plug to 5-pin round plug/socket M12 – Bus terminating resistor must be connected externally 	533 118	FBA-2-M12-5POL-RK	
Plug for CANopen				
	<ul style="list-style-type: none"> – 9-pin Sub-D connection – Bus terminating resistor integrated – Position of DIL switch can be read externally – IP65 	532 219	FBS-SUB-9-BU-2x5POL-B	
Bus connection adapter for CANopen				
	<ul style="list-style-type: none"> – 9-pin Sub-D plug to 5-pin round plug/socket M12 – Bus terminating resistor must be connected externally 	525 632	FBA-2-M12-5POL	
	<ul style="list-style-type: none"> – 9-pin Sub-D plug on 5-pin strip – Bus terminating resistor must be connected externally 	525 634	FBA-1-SL-5POL	
	<ul style="list-style-type: none"> – 5-pin terminal strip for connecting the fieldbus cable to the bus connection adapter FBA-1-SL-5POL 	525 635	FBSD-KL-2x5PIN	

Motor controllers SFC-DC

Accessories



Drives with linear guides
Slides

6.1

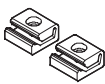
Ordering data – Central supports			
	Brief description	Part No.	Type
	Centre supports for mounting controller	160 909	MUP-8/12

Ordering data – Software			
	Brief description	Part No.	Type
	Operating package contains: – CD-ROM – with user documentation for SFC-DC, in the languages de, en, es, fr, it, sv – with configuration software FCT (Festo Configuration Tool) – Brief description This operating package is included in the scope of delivery.	550 140	P.BP-SFC-DC

Ordering data – Documentation ¹⁾							
Description	Language	For I/O interface		For Profibus interface		For CANopen interface	
		Part No.	Type	Part No.	Type	Part No.	Type
	DE	540 417	P.BE-SFC-DC-IO-DE	540 411	P.BE-SFC-DC-PB-DE	540 423	P.BE-SFC-DC-CO-DE
	EN	540 418	P.BE-SFC-DC-IO-EN	540 412	P.BE-SFC-DC-PB-EN	540 424	P.BE-SFC-DC-CO-EN
	ES	540 419	P.BE-SFC-DC-IO-ES	540 413	P.BE-SFC-DC-PB-ES	540 425	P.BE-SFC-DC-CO-ES
	FR	540 420	P.BE-SFC-DC-IO-FR	540 414	P.BE-SFC-DC-PB-FR	540 426	P.BE-SFC-DC-CO-FR
	IT	540 421	P.BE-SFC-DC-IO-IT	540 415	P.BE-SFC-DC-PB-IT	540 427	P.BE-SFC-DC-CO-IT
	SV	540 422	P.BE-SFC-DC-IO-SV	540 416	P.BE-SFC-DC-PB-SV	540 428	P.BE-SFC-DC-CO-SV

1) User documentation in paper form is not included in the scope of delivery

Motor controllers SFC-DC

Technical data



FCT software – Festo Configuration Tool

Software platform for electrical drives from Festo

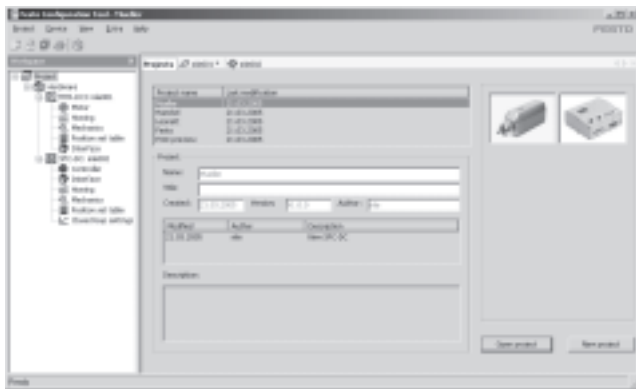

- All the drives in a system can be managed and archived in a common project
- Project and data management for all supported device types
- Simple to use thanks to graphically supported parameter entry
- Universal mode of operation for all drives
- Working offline at your desk or online at the machine

Mechanical reference positions and limit positions

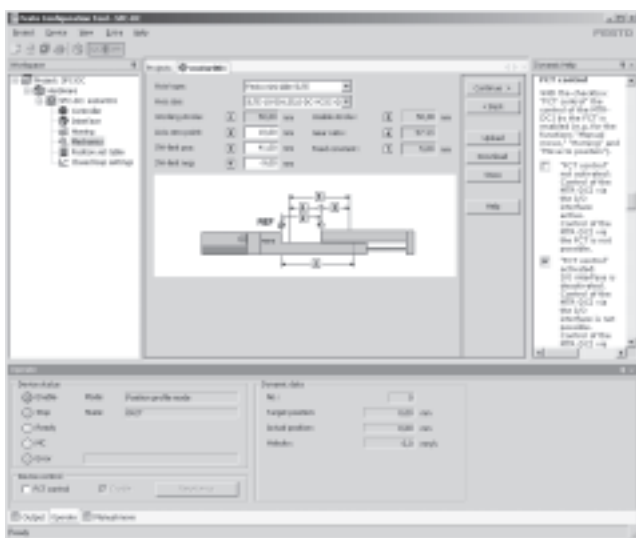

- Reference positions can be either edited or taught in
- Flexible adaptation to installation conditions
- Settings are displayed clearly

Position set table



- 31 position sets ensure flexibility in positioning
- Absolute or relative positioning values can be used
- The following parameters can be set flexibly for each application:
 - Position
 - Speed
 - Acceleration
 - Braking ramps
- Complete function test

Motor controllers SFC-DC

Technical data

FHPP – Festo handling and positioning profile

Optimised data profile

Festo has developed an optimised data profile, the “Festo handling and positioning profile (FHPP)”, that is tailored to the target applications for handling and positioning tasks.

The FHPP data profile permits the activation of Festo motor controllers, using a fieldbus interface, via standardised control and status bytes.

The following are defined, among others:

- Operating modes
- I/O data structure
- Parameter objects
- Sequence control

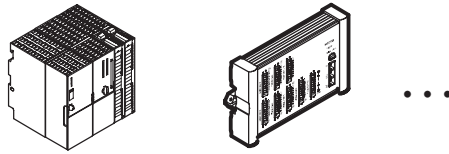

Fieldbus communication

Set selection

Direct operation

Parameter channel

