



- Multi-axis and drive combinations
- Recirculating ball bearing guide
- Individualised position sensing and end-position cushioning

# Linear drives SLM, with guided slide

Key features



## Version

The linear drive SLM is a combination of a slide unit and a rodless linear drive. The drive moves the slide. The

transmission of movement is accomplished via a magnetic coupling. The modular system allows

for individualised end-position cushioning and end-position sensing solutions.

## Basic unit

### SLM-...-G

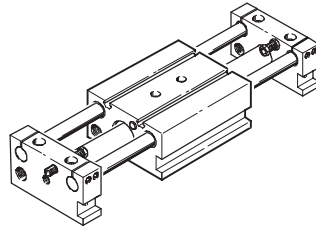

### SLM-...-GL

with hollow guide rods

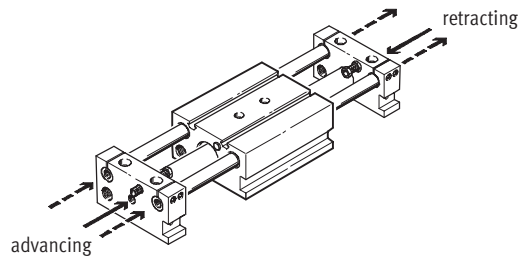

### SLM-...-GU

with hollow guide rods, air diverting plate and supply port on one side

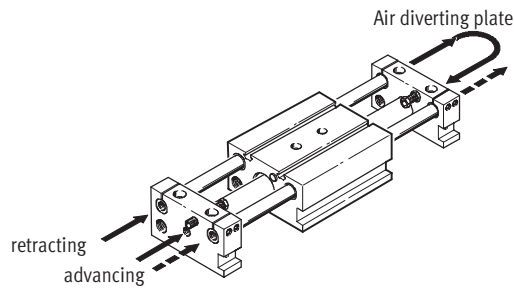

## Standard unit

### SLM-...-S

with two self-adjusting shock absorbers and two inductive proximity sensors with PNP output

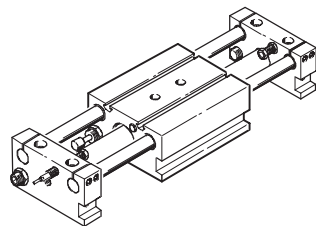

# Linear drives SLM, with guided slide

Key features

## Multi-axis combinations

The linear drive SLM can be combined with the linear unit SLE to produce a range of 2-axis or 3-axis systems.

These multi-axis configurations are formed by screwing the units together, either directly or using an adapter plate. A linear unit SLE can be combined with another linear unit SLE using either method, however direct

mounting is almost always required for a linear drive SLM and linear unit SLE. The centring pins and sleeves required to secure the units together are included in the scope of delivery.

Linear unit SLE  
→ 1 / 6.2-126

X	Y	Z
<b>2 axes</b>		
SLM-12	SLE-10	–
SLM-16 <sup>1)</sup>	SLE-10	–
SLM-20	SLE-16	–
SLM-25 <sup>2)</sup>	SLE-16	–
SLM-32	SLE-20 or SLE-25	–
SLM-40	SLE-32	–
<b>3 axes</b>		
SLM-20	SLE-16	SLE-10
SLM-25 <sup>2)</sup>	SLE-16	SLE-10
SLM-32	SLE-20 or SLE-25	SLE-16
SLM-40	SLE-32	SLE-20 or SLE-25

- 1) An adapter plate SLEP-10 (→ 1 / 3.2-28) is required for mounting (direct mounting is not possible).
- 2) An adapter plate SLEP-16 (→ 1 / 3.2-28) is required for mounting (direct mounting is not possible).

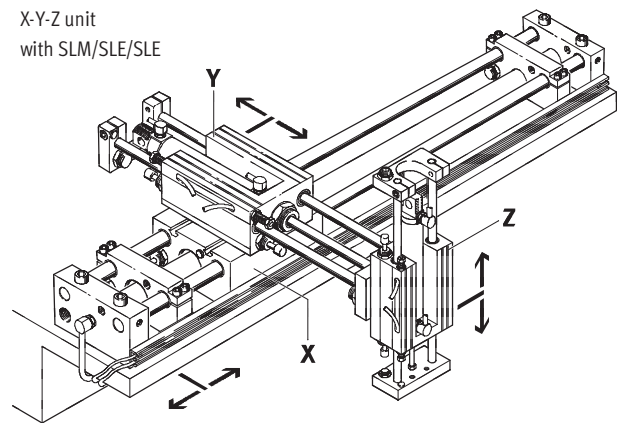

Rodless cylinders  
Magnetically coupled

3.2

# Linear drives SLM, with guided slide

Peripherals overview



Rodless cylinders  
Magnetically coupled

3.2

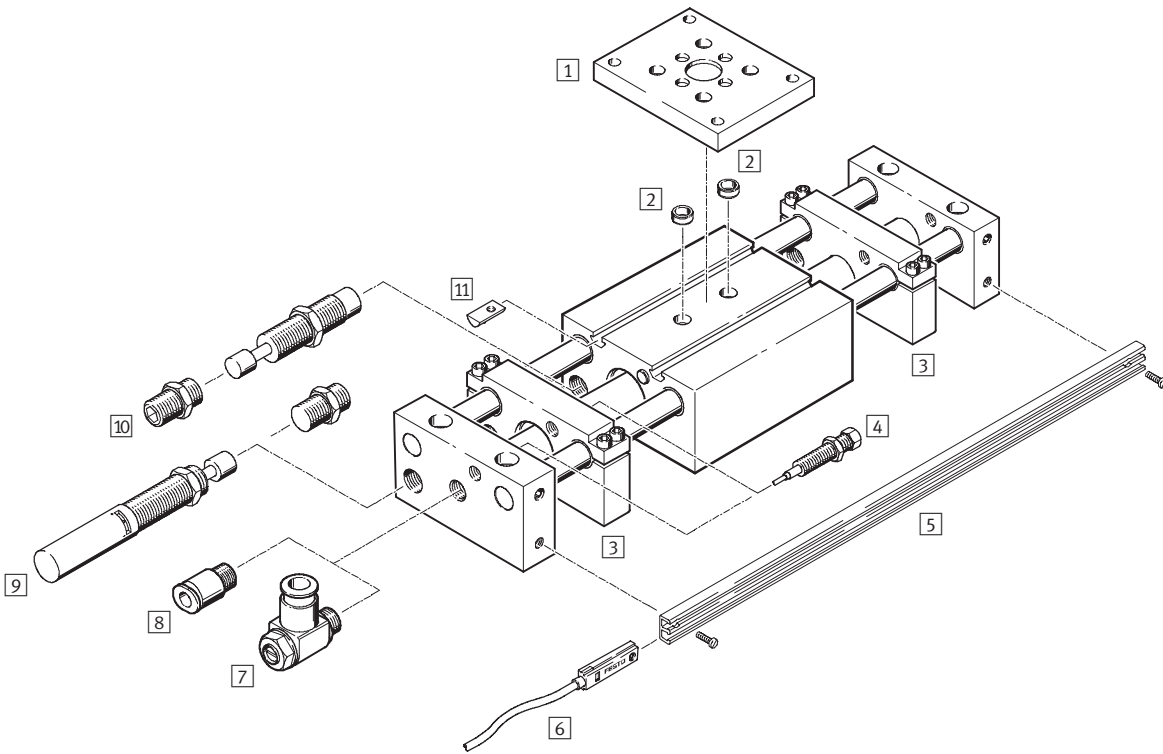

## Linear drives SLM, with guided slide

Peripherals overview

FESTO

Accessories		
	Brief description	→ Page
1	Adapter plate SLEP	1 / 3.2-28
2	Centring sleeve ZBH	1 / 3.2-29
3	Stop plate SLM-...-KF-A	1 / 3.2-29
4	Switching stop with proximity sensor SL-...-SIE-PS/SL-...-SIE-NS	1 / 3.2-28
5	Mounting rail SLZS/SLMS	1 / 3.2-29
6	Proximity sensor SME/SMT-8	1 / 3.2-29
7	One-way flow control valve GRLA	1 / 3.2-30
8	Push-in fitting QS	Volume 3
9	Shock absorber kit, adjustable SLZ-...-KF-A	1 / 3.2-27
10	Shock absorber kit, self-adjusting SLZ-...-YSR-C	1 / 3.2-27
11	Slot nut NST	1 / 3.2-29

Rodless cylinders  
Magnetically coupled

3.2

# Linear drives SLM, with guided slide

Type code

FESTO

Rodless cylinders  
Magnetically coupled

3.2

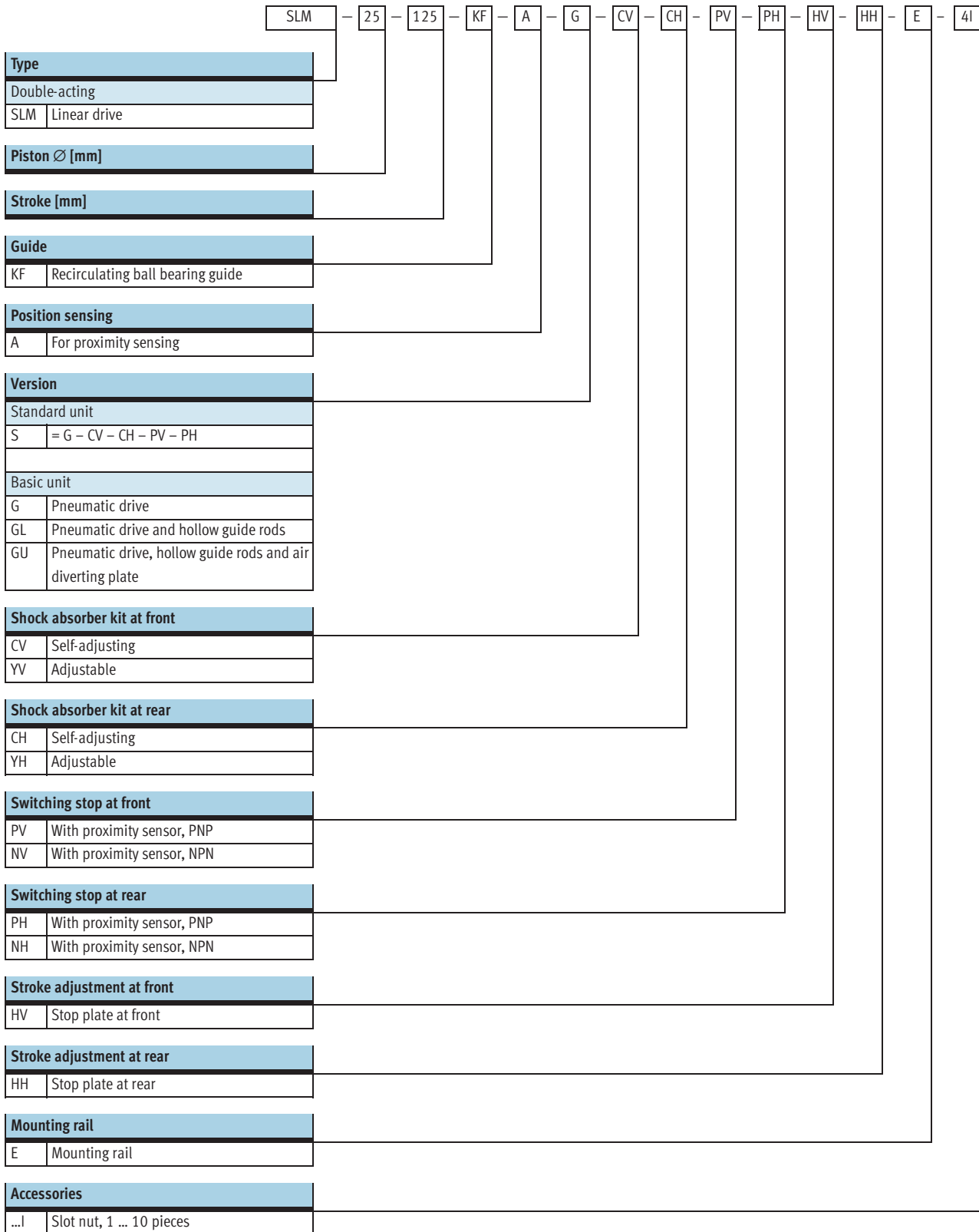

# Linear drives SLM, with guided slide

Technical data

Function

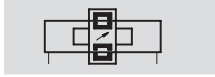

[www.festo.com/en/Spare\\_parts\\_service](http://www.festo.com/en/Spare_parts_service)

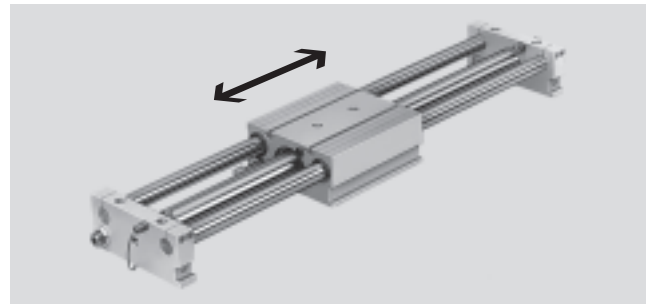

- $\varnothing$  - Diameter  
12 ... 40 mm
- | - Stroke length  
10 ... 1500 mm

General technical data						
Piston $\varnothing$	12	16	20	25	32	40
Stroke [mm]	10 ... 500	10 ... 800		10 ... 1500		
Pneumatic connection	M5		G1/8		G1/4	
Mode of operation	Double-acting					
Constructional design	Slide unit					
	Rodless linear drive					
End-position cushioning via shock absorber	Self-adjusting at both ends					
	-	-	Adjustable at both ends			
Position sensing	For proximity sensing					
Type of mounting	Via through-holes					
	Via female thread					
Mounting position	Any					
Protection against torsion/guide	Guide rods with slide/ball bearing guide					

Operating and environmental conditions						
Piston $\varnothing$	12	16	20	25	32	40
Operating medium	Filtered compressed air, lubricated or unlubricated					
Operating pressure [bar]	$\leq 7$					
Ambient temperature <sup>1)</sup> [°C]	-20 ... +60					

1) Note operating range of proximity sensors.

Forces [N]						
Piston $\varnothing$	12	16	20	25	32	40
Theoretical force at 6 bar, advancing	68	121	188	295	483	754
Theoretical force at 6 bar, retracting	68	121	188	295	483	754
Breakaway force of the magnetic coupling	100	160	270	400	680	1050

# Linear drives SLM, with guided slide

Technical data



## Permissible dynamic load

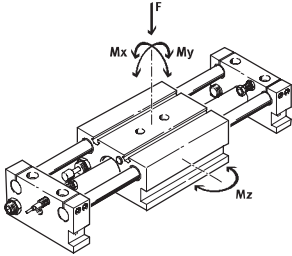

$F = \text{Load}$   
 $M \geq M_x$   
 $M \geq M_y$   
 $M \geq M_z$

## Permissible effective load F as a function of the stroke l

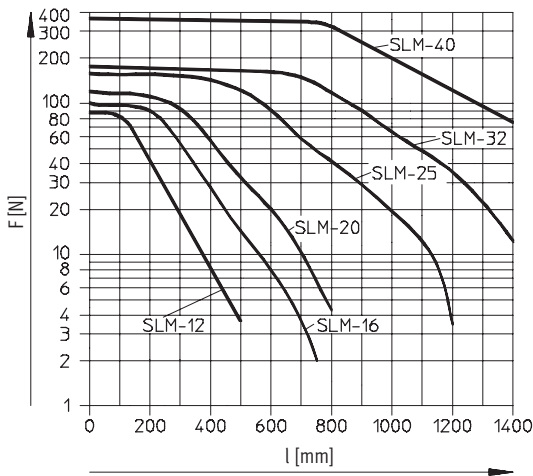

## Permissible torque M as a function of the stroke l

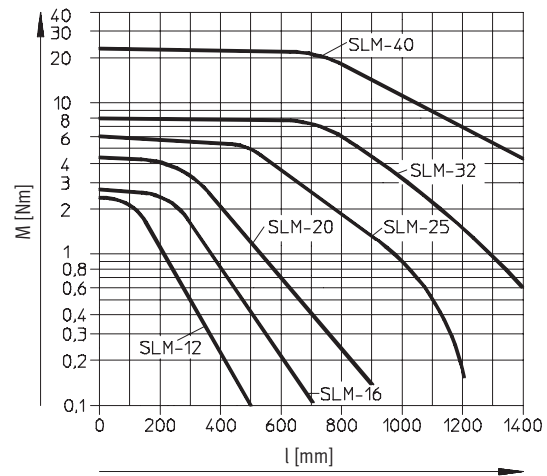

## Permissible shock absorber load F as a function of the impact velocity v

with horizontal installation

$$F \geq m_L \times g$$

$$g = 9.81 \text{ N/mm}^2$$

$$m_L = \text{Load [kg]}$$

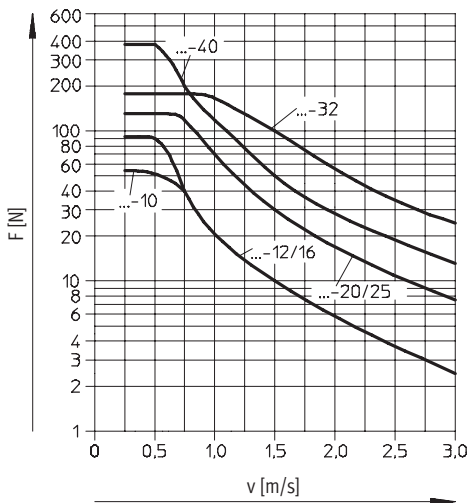

with vertical installation

$$F \geq (m_L + m_E) \times g$$

$$g = 9.81 \text{ N/mm}^2$$

$$m_E = \text{Moving load (dead weight) [kg]}$$

$$m_L = \text{Load [kg]}$$

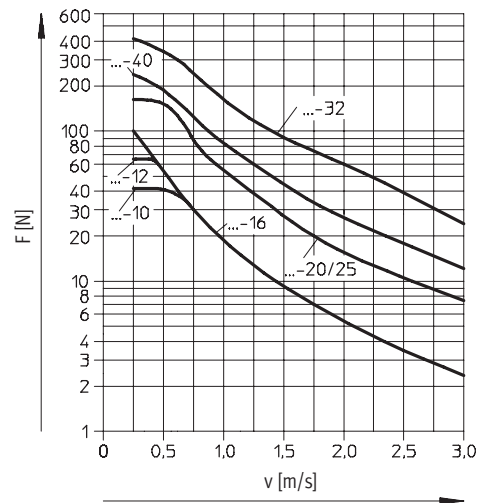

Rodless cylinders  
Magnetically coupled

3.2



# Linear drives SLM, with guided slide

Technical data

Weights [g]						
Piston Ø	12	16	20	25	32	40
Basic weight with 0 mm stroke	1110	1730	2620	3800	6400	9550
Additional weight per 10 mm stroke	10	15	21	36	55	85
Moving load	620	1080	1400	2150	3150	5080

## Materials

Sectional view

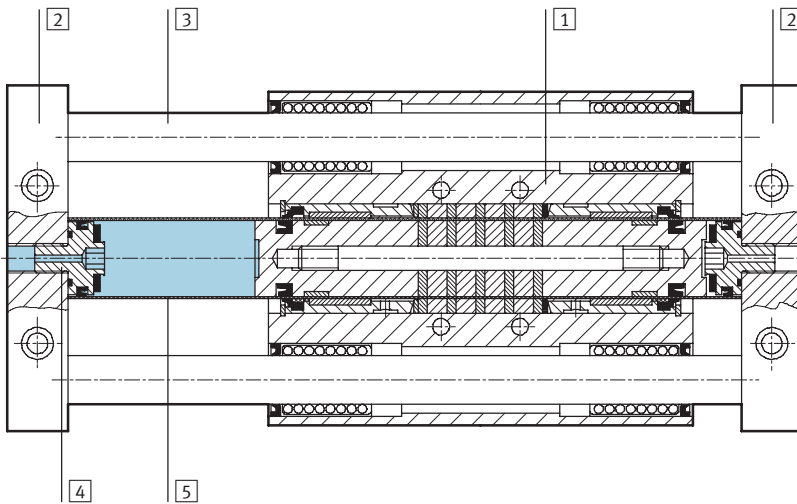

Linear drive	
1	Slide Wrought aluminium alloy
2	End plate Wrought aluminium alloy
3	Guide rod Steel
4	Cylinder barrel attachment Wrought aluminium alloy
5	Cylinder barrel High-alloy stainless steel
-	Stop plate Wrought aluminium alloy
-	Seals Nitrile rubber

Rodless cylinders  
Magnetically coupled

3.2

# Linear drives SLM, with guided slide

Technical data



## Dimensions

Download CAD data → [www.festo.com/en/engineering](http://www.festo.com/en/engineering)

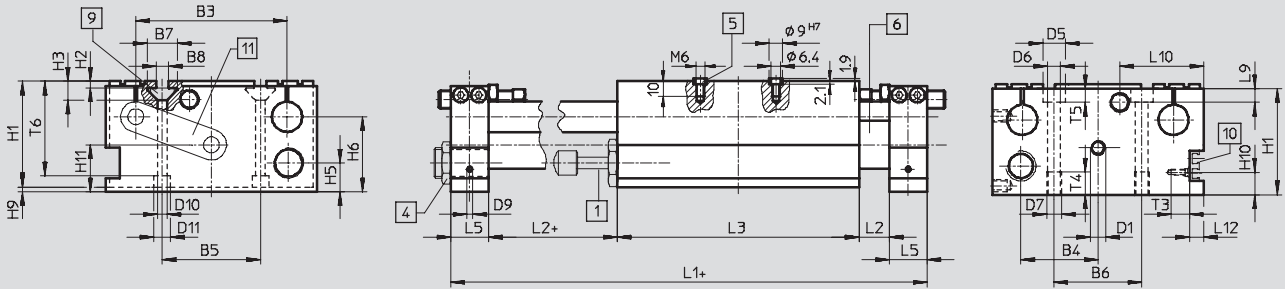

View A

SLM-40

SLM-12 ... 32

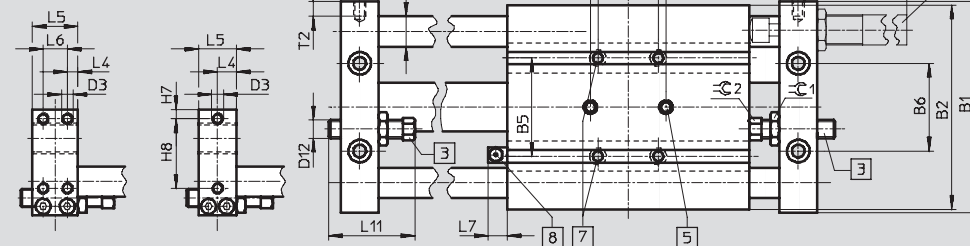

- |   |  |                                |   |
|---|--|--------------------------------|---|
| 1 Self-adjusting shock absorber, for front and rear mounting              | 3 Switching stop with proximity sensor, PNP/NPN, for front and rear mounting | 6 Pneumatic linear drive       | 10 Mounting rail for proximity sensor SME/SMT-8 |
| 2 Adjustable shock absorber, for front and rear mounting on the end plate | 4 Shock absorber stop  | 7 Mounting thread/through-hole | 11 Air diverting plate                          |
|   | 5 Centring sleeves (2 included in scope of delivery)                         | 8 Lubrication nipple           | + = plus stroke length                          |
|   |  | 9 Slot nut                     |   |

## with stop plate

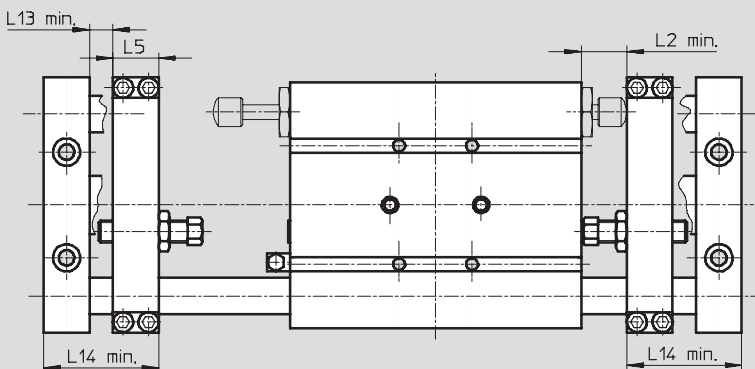

Note

In the case of stroke settings with stop plates front and/or rear, the stroke is reduced by L5 and L13 min at each end.

## with hollow guide rod and air diverting plate

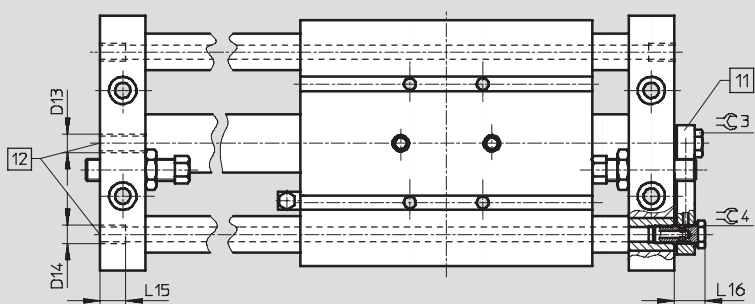

- |                        |
|------------------------|
| 11 Air diverting plate |
| 12 Supply port         |

# Linear drives SLM, with guided slide

Technical data

∅	B1	B2	B3	B4	B5	B6	B7	B8	D1	D3	D4 ∅ h6	D5 ∅	D6 ∅	D7	D9
[mm]															
12	74	71	52	26.5	26	35	11.6	5	M5	M5	8	10	5.3	M6	M4
16	84	80	58	31	32	40	11.6	5	M5	M5	10	10	5.3	M6	M4
20	100	96	72	36.5	40	47	11.6	5	G $\frac{1}{8}$	M6	12	11	6.8	M8	M4
25	114	110	80	39.5	45	48	11.6	5	G $\frac{1}{8}$	M6	16	10.5	6.8	M8	M4
32	140	135	100	51	65	58	20	8	G $\frac{1}{8}$	M8	20	15	8.5	M10	M4
40	166	160	118	63	75	78	20	8	G $\frac{1}{4}$	M6	25	15	8.5	M10	M4

∅	D10 ∅	D11 ∅	D12	D13	D14	H1	H2	H3	H4	H5	H6	H7	H8	H9
[mm]														
12	5.3	9	M6x0.75	M5	-	38	1.8	6.4	77	11.5	27	3.5	31	2
16	5.5	10	M6x0.75	M5	M5	40	1.8	6.4	77	12	28.5	4.5	31	2
20	5.5	10	M8x1	G $\frac{1}{8}$	M5	50	1.8	6.4	128	16	36	5	40	2
25	5.5	10	M8x1	G $\frac{1}{8}$	G $\frac{1}{8}$	55	1.8	6.4	128	14	36.5	5	34	2
32	6.6	11	M12x1	G $\frac{1}{8}$	G $\frac{1}{8}$	70	4.5	12.5	160	19	49.5	6	46	3
40	6.6	11	M12x1	G $\frac{1}{4}$	G $\frac{1}{4}$	75	4.5	12.5	160	19	51	5.5	51.5	3

∅	H10	H11	L1	L2	L3	L4	L5	L6	L7	L8	L9	L10	L11
[mm]													
12	16	15.5	139	12	85	7.5	15	-	11	19	6.5	37	33
16	16	19	154	12	100	7.5	15	-	11	32	6	31.5	33
20	16	22	192	16	120	10	20	-	12.5	26	8	44	45
25	16	25	212	16	140	10	20	-	12.5	26	8	45	45
32	14.8	31	250	20	160	12.5	25	-	12.5	40	9	55.5	57
40	15.8	36.5	270	20	180	6.5	25	12	12.5	50	9	61.5	57

∅	L12	L13	L14	L15	L16	T2	T3	T4	T5	T6	≈C1	≈C2	≈C3	≈C4
[mm]														
12	-	7	37	-	-	7	12	10	5.7	30.5	10	8	-	-
16	-	7	37	8	12.5	6.5	12	10	5.7	34.3	10	8	13	-
20	-	10	50	8	19.5	9	12	12	6.8	44	13	11	13	8
25	-	10	50	10	19.5	9	12	12	6.8	49.3	13	11	13	-
32	9.5	13	63	14	15.5	10	12	15	9	62.5	19	13	13	-
40	10	13	63	15	17	10	12	16	9	61	19	13	17	-

Rodless cylinders  
Magnetically coupled

## 3.2

# Linear drives SLM, with guided slide

Ordering data – Modular products



Rodless cylinders  
Magnetically coupled

3.2

**M** Mandatory data →

Module No.	Drive function	Size	Stroke	Guide	Position sensing	Basic unit
32 781	SLM	12	10 ... 1500	KF	A	G
32 782		16				GL
32 783		20				GU
32 784		25				
32 785		32				
32 786		40				
<b>Ordering example</b>						
<b>32 784</b>	<b>SLM</b>	<b>- 25</b>	<b>- 900</b>	<b>- KF</b>	<b>- A</b>	<b>- GU</b>

Ordering table									
Size	12	16	20	25	32	40	Condi- tions	Code	Enter code
<b>M</b> Module No.	<b>32 781</b>	<b>32 782</b>	<b>32 783</b>	<b>32 784</b>	<b>32 785</b>	<b>32 786</b>			
Drive function	Linear unit							<b>SLM</b>	SLM
Size [mm]	12	16	20	25	32	40		-...	
Stroke [mm]	10 ... 500		10 ... 800		10 ... 1500			-...	
Guide	Via ball bearings							<b>-KF</b>	-KF
Position sensing	For proximity sensing							<b>-A</b>	-A
Basic unit	Linear unit with pneumatic drive							<b>-G</b>	
	- Linear unit with pneumatic drive and hollow guide rods							<b>-GL</b>	
	- Linear unit with pneumatic drive, hollow guide rods and air diverting plate							<b>-GU</b>	

Transfer order code

- 
 - 
 - 
 - 
 - 
 -

# Linear drives SLM, with guided slide

Ordering data – Modular products



Options							
Shock absorber at front	Shock absorber at rear	Sensor at front	Sensor at rear	Stroke adjustment at front	Stroke adjustment at rear	Mounting rail	Slot nut
CV YV	CH YH	PV NV	PH NH	HV	HH	E	...I
CV	- CH	- PV	- PH	- HV	- HH	- E	- 4I

Ordering table											
Size	12	16	20	25	32	40	Condi- tions	Code		Enter code	
Shock absorber	at front	Self-adjusting shock absorber, with stop at front							-CV		
		Adjustable shock absorber, with stop at front							-YV		
	at rear	Self-adjusting shock absorber, with stop at rear							-CH		
		Adjustable shock absorber, with stop at rear							-YH		
Sensor (bonded)	at front	Inductive sensor with 2.5 m cable, PNP, with stop sleeve at front							-PV		
		Inductive sensor with 2.5 m cable, NPN, with stop sleeve at front							-NV		
	at rear	Inductive sensor with 2.5 m cable, PNP, with stop sleeve at rear							-PH		
		Inductive sensor with 2.5 m cable, NPN, with stop sleeve at rear							-NH		
Stroke adjustment	at front	Stop plate at front						1	-HV		
	at rear	Stop plate at rear						2	-HH		
Mounting rail	Mounting rail							-E			
Slot nut	1 ... 10							-...I			

- 1 HV Not in combination with YV
- 2 HH Not in combination with YH

Transfer order code

-  -  -  -  -  -  -

# Linear drives SLM, with guided slide

Ordering data – Modular products, package solution



Rodless cylinders  
Magnetically coupled

3.2

Mandatory data						
Module No.	Drive function	Size	Stroke	Guide	Position sensing	Standard unit
32 781	SLM	12	10 ... 1500	KF	A	S
32 782		16				
32 783		20				
32 784		25				
32 785		32				
32 786		40				
<b>Ordering example</b>						
32 782	SLM	- 16	- 750	- KF	- A	- S

Ordering table									
Size	12	16	20	25	32	40	Condi- tions	Code	Enter code
M Module No.	32 781	32 782	32 783	32 784	32 785	32 786			
Drive function	Linear unit							SLM	SLM
Size [mm]	12	16	20	25	32	40	-...		
Stroke [mm]	10 ... 500	10 ... 800		10 ... 1500			-...		
Guide	Via ball bearings							-KF	-KF
Position sensing	For proximity sensing							-A	-A
Standard unit	Package solution S = G-CV-CH-PV-PH							-S	-S

Transfer order code

	SLM	-		-		-	KF	-	A	-	S
--	-----	---	--	---	--	---	----	---	---	---	---

# Linear drives SLM, with guided slide

Accessories

**Shock absorber kit  
SLZ-...-YSR-C, self-adjusting**  
(order code CV, CH)

Material:  
YSR-8-8-C: Nickel-plated brass  
YSR-12-12-C, YSR-16-20-C:  
Galvanised steel  
Free of copper, PTFE and silicone



Ordering data			
For Ø [mm]	including shock absorber Technical data → 1 / 9.0-2	Part No.	Type
12, 16	YSR-8-8-C	115 315	SLZ-16-YSR-C
20, 25	YSR-12-12-C	115 316	SLZ-25-YSR-C
32, 40	YSR-16-20-C	115 317	SLZ-32-YSR-C

**Shock absorber kit  
SLZ-...-KF-A, adjustable**  
(order code YV, YH)

Material:  
Galvanised steel



Ordering data			
For Ø [mm]	including shock absorber Technical data → 1 / 9.0-2	Part No.	Type
20, 25	YSR-12-12	114 032	SLZ-25-KF-A
32, 40	YSR-16-20	114 033	SLZ-32-KF-A

# Linear drives SLM, with guided slide

Accessories



### Switching stop SL-...-SIE-PS

(order code PV, PH)

Kit with inductive proximity sensor  
PNP

### Switching stop SL-...-SIE-NS

(order code NV, NH)

Kit with inductive proximity sensor  
NPN



Ordering data				
For Ø [mm]	Switch output	Including proximity sensor Technical data → Volume 4	Part No.	Type
12, 16	PNP	SIEN-4B-PS-K-L	116 251	SL-10/16-SIE-PS
	NPN	SIEN-4B-NS-K-L	116 252	SL-10/16-SIE-NS
20, 25	PNP	SIEN-4B-PS-K-L	116 253	SL-20/25-SIE-PS
	NPN	SIEN-4B-NS-K-L	116 254	SL-20/25-SIE-NS
32, 40	PNP	SIEN-6,5B-PS-K-L	117 525	SL-32/50-SIE-PS
	NPN	SIEN-6,5B-NS-K-L	117 526	SL-32/50-SIE-NS

Rodless cylinders  
Magnetically coupled

## 3.2

### Adapter plate SLEP

Material:

Wrought aluminium alloy

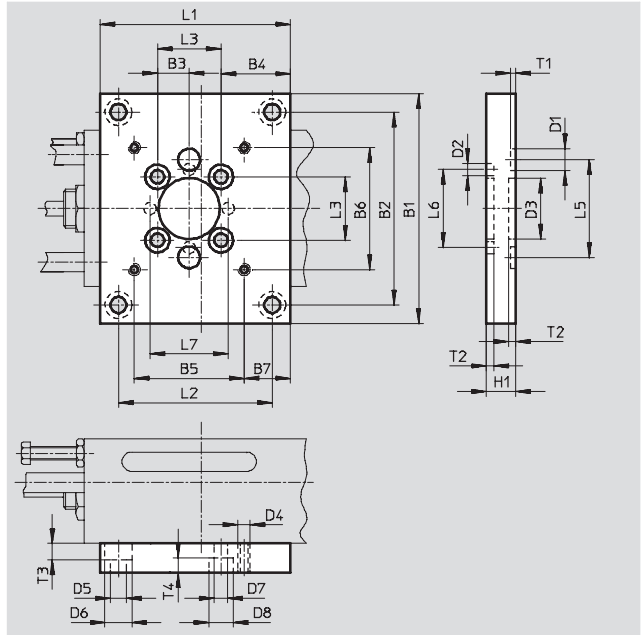
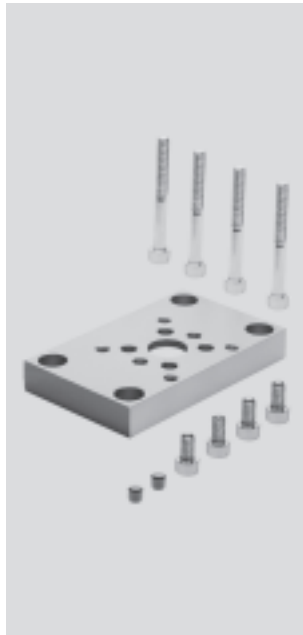

Dimensions and ordering data																		
For Ø	B1	B2	B3	B4	B5	B6	B7	D1	D2	D3	D4	D5	D6	D7	D8	H1	L1	L2
[mm]								Ø H7	Ø H7	Ø G7		Ø	Ø	Ø	Ø			
16	82	68	9.5	20	32	32	13.5	9	5	14	M5	5.5	10	5.5	10	12	50	36
25	94	79	13	23.5	45	26	14	9	5	25	M5	6.6	11	5.5	10	12	73	58

For Ø	L3	L5	L6	L7	T1	T2	T3	T4	Weight	Part No.	Type
[mm]									[g]		
16	19	40	28	-	2.1	3	5.7	6.7	122	150 909	SLEP-10
25	26	40	32	32	2.1	3	6.8	6.7	205	150 910	SLEP-16



# Linear drives SLM, with guided slide

Accessories



Ordering data – Accessories						
	For Ø [mm]	Material	Order code	Part No.	Type	PU <sup>1)</sup>
<b>Stop plate SLM-...-KF-A</b>						
	12	Wrought aluminium alloy	HV, HH	<b>119 527</b>	<b>SLM-12-...-KF-A</b>	1
	16			<b>119 528</b>	<b>SLM-16-...-KF-A</b>	1
	20			<b>119 529</b>	<b>SLM-20-...-KF-A</b>	1
	25			<b>119 530</b>	<b>SLM-25-...-KF-A</b>	1
	32			<b>119 531</b>	<b>SLM-32-...-KF-A</b>	1
	40			<b>119 532</b>	<b>SLM-40-...-KF-A</b>	1
	<b>Mounting rail SLZS/SLMS for proximity sensor</b>					
	12	Wrought aluminium alloy	E	<b>150 916</b>	<b>SLZS-16-...-...</b>	1
	16			<b>152 744</b>	<b>SLMS-16-...-...</b>	1
	20			<b>150 917</b>	<b>SLZS-25-...-...</b>	1
	25			<b>152 745</b>	<b>SLMS-25-...-...</b>	1
	32			<b>150 918</b>	<b>SLZS-32-...-...</b>	1
	40			<b>150 919</b>	<b>SLZS-40-...-...</b>	1
	<b>Slot nut NST</b> <span style="float: right;">Technical data → 1 / 10.1-16</span>					
	12 ... 25	Non-alloyed tempered steel	I	<b>150 914</b>	<b>NST-5-M5</b>	1
	32, 40	Free of copper, PTFE and silicone		<b>150 915</b>	<b>NST-8-M6</b>	1
<b>Centring sleeve ZBH</b> <span style="float: right;">Technical data → 1 / 10.1-18</span>						
	16 ... 40	Stainless steel Free of copper, PTFE and silicone	-	<b>150 927</b>	<b>ZBH-9</b>	10

1) Packaging unit quantity

Ordering data – Proximity switches for T-slot, magnetic reed						Technical data → <a href="http://www.festo.com/catalogue/sm">www.festo.com/catalogue/sm</a>
	Type of mounting	Switch output	Electrical connection	Cable length [m]	Part No.	Type
<b>N/O contact</b>						
	Insertable in the slot from above, flush with cylinder profile	Contacting	Cable, 3-wire	2,5	<b>543 862</b>	<b>SME-8M-DS-24V-K-2,5-OE</b>
				5,0	<b>543 863</b>	<b>SME-8M-DS-24V-K-5,0-OE</b>
			Plug M8x1, 3-pin	2,5	<b>543 872</b>	<b>SME-8M-ZS-24V-K-2,5-OE</b>
				0,3	<b>543 861</b>	<b>SME-8M-DS-24V-K-0,3-M8D</b>
	Insertable in the slot lengthwise, flush with the cylinder profile	Contacting	Cable, 3-wire	2,5	<b>150 855</b>	<b>SME-8-K-LED-24</b>
				0,3	<b>150 857</b>	<b>SME-8-S-LED-24</b>
<b>N/C contact</b>						
	Insertable in the slot lengthwise, flush with the cylinder profile	Contacting	Cable, 3-wire	7,5	<b>160 251</b>	<b>SME-8-O-K-LED-24</b>

Rodless cylinders  
Magnetically coupled

3.2



# Linear drives SLM, with guided slide



Accessories

FESTO

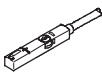
Rodless cylinders  
Magnetically coupled

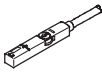
3.2

Ordering data – Proximity switches for T-slot, magneto-resistive					Technical data → <a href="http://www.festo.com/catalogue/sm">www.festo.com/catalogue/sm</a>	
	Type of mounting	Switch output	Electrical connection	Cable length [m]	Part No.	Type
<b>N/O contact</b>						
	Insertable in the slot from above, flush with cylinder profile	PNP	Cable, 3-wire	2,5	543 867	SMT-8M-PS-24V-K-2,5-OE
			Plug M8x1, 3-pin	0,3	543 866	SMT-8M-PS-24V-K-0,3-M8D
			Plug M12x1, 3-pin	0,3	543 869	SMT-8M-PS-24V-K-0,3-M12
		NPN	Cable, 3-wire	2,5	543 870	SMT-8M-NS-24V-K-2,5-OE
Plug M8x1, 3-pin	0,3		543 871	SMT-8M-NS-24V-K-0,3-M8D		
	Insertable in the slot lengthwise, flush with the cylinder profile	PNP	Cable, 3-wire	2,5	175 436	SMT-8-PS-K-LED-24-B
			Plug M8x1, 3-pin	0,3	175 484	SMT-8-PS-S-LED-24-B
<b>N/C contact</b>						
	Insertable in the slot from above, flush with cylinder profile	PNP	Cable, 3-wire	7,5	543 873	SMT-8M-PO-24V-K7,5-OE

Ordering data – Connecting cables				Technical data → <a href="http://www.festo.com/catalogue/nebu">www.festo.com/catalogue/nebu</a>	
	Electrical connection, left	Electrical connection, right	Cable length [m]	Part No.	Type
	Straight socket, M8x1, 3-pin	Cable, open end, 3-wire	2,5	541 333	NEBU-M8G3-K-2.5-LE3
			5	541 334	NEBU-M8G3-K-5-LE3
	Straight socket, M12x1, 5-pin	Cable, open end, 3-wire	2,5	541 363	NEBU-M12G5-K-2.5-LE3
			5	541 364	NEBU-M12G5-K-5-LE3
	Angled socket, M8x1, 3-pin	Cable, open end, 3-wire	2,5	541 338	NEBU-M8W3-K-2.5-LE3
			5	541 341	NEBU-M8W3-K-5-LE3
	Angled socket, M12x1, 5-pin	Cable, open end, 3-wire	2,5	541 367	NEBU-M12W5-K-2.5-LE3
			5	541 370	NEBU-M12W5-K-5-LE3

Ordering data – Slot cover for T-slot			
	Mounting	Length [m]	Part No. Type
	Insertable from above	2x 0.5	151 680 ABP-5-S

Ordering data – One-way flow control valves				Technical data → Volume 2	
	Connection		Material	Part No.	Type
	Thread	For tubing OD			
	M5	3	Metal design	193 137	GRLA-M5-QS-3-D
		4		193 138	GRLA-M5-QS-4-D
		6		193 139	GRLA-M5-QS-6-D
	G1/8	3		193 142	GRLA-1/8-QS-3-D
		4		193 143	GRLA-1/8-QS-4-D
		6		193 144	GRLA-1/8-QS-6-D
		8		193 145	GRLA-1/8-QS-8-D
		10		193 146	GRLA-1/8-QS-10-D
	G1/4	6		193 147	GRLA-1/4-QS-6-D
		8		193 148	GRLA-1/4-QS-8-D
		10			