

- High positioning accuracy
- High torques
- High dynamics
- Co-ordinated motor controller combinations

Servo motors MTR-AC

Key features

FESTO

At a glance

Motors MTR-AC

→ 5 / 2.2-30

- System product for positioning applications
- Without/with brake
- Without/with gear unit
- High power density
- High dynamics
- With attached or integrated gear unit
- Controlled operation
- High torque over entire rpm range
- Good positioning characteristics



Motor flange MTR-FL

→ 5 / 2.2-36

- The right motor flange for every motor axis combination



Motor cable KMTR-AC/KRES-AC/KSEC-AC

→ 5 / 2.2-37

- Screened cable
- Can be used at -40 ... +125 °C
- Suitable for chain link trunking
- Protection class IP54



Motor controller SEC-AC

→ 5 / 2.2-38

- System product for positioning applications
- Compact unit, ready for installation
- Pre-set axis-adapted controller parameters
- Pre-assembled electrical connection accessories
- Mounting via H-rail
- Fieldbus interface optional

PROFI

CANopen



Servo motors MTR-AC

Selection aid

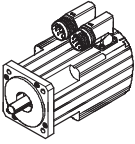
	Motor version	Torque at standstill M_0 in Nm	With gear unit, reduction ratio 4:1	With brake	→ Page
	MTR-AC-40-3S-AA	0.27	-	-	5 / 2.2-28
	MTR-AC-40-3S-AB	0.27	-	■	
	MTR-AC-55-3S-AA	0.98	-	-	
	MTR-AC-55-3S-AB	0.98	-	■	
	MTR-AC-55-3S-GA	3.7	■	-	
	MTR-AC-55-3S-GB	3.7	■	■	
	MTR-AC-70-3S-AA	1.64	-	-	
	MTR-AC-70-3S-AB	1.64	-	■	
	MTR-AC-70-3S-GA	6.4	■	-	
	MTR-AC-70-3S-GB	6.4	■	■	
	MTR-AC-100-3S-AA	4.74	-	-	
	MTR-AC-100-3S-AB	4.74	-	■	
	MTR-AC-100-3S-GA	18.5	■	-	
	MTR-AC-100-3S-GB	18.5	■	■	
	MTR-AC-100-5S-AA	12.53	-	-	
	MTR-AC-100-5S-AB	12.53	-	■	
	MTR-AC-100-5S-GA	49.1	■	-	
	MTR-AC-100-5S-GB	49.1	■	■	

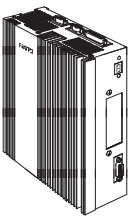
	Motor controller version	Nominal power in VA	Peak power in VA	Programmable positions	Fieldbus coupling	→ Page
	SEC-AC-305/P01	1000	3000	16	-	5 / 2.2-38
	SEC-AC-508/P01	4000	9000	16	-	
	SEC-AC-305-PB-P01	1000	3000	16	Profibus DP	
	SEC-AC-508-PB-P01	4000	9000	16	Profibus DP	
	SEC-AC-305-CO-P01	1000	3000	16	CANopen	
	SEC-AC-508-CO-P01	4000	9000	16	CANopen	

Servo motors MTR-AC

Selection aid



Permissible combinations						
Motor	MTR-AC-40-3S-AA MTR-AC-40-3S-AB	MTR-AC-55-3S-AA ¹⁾ MTR-AC-55-3S-AB ¹⁾	MTR-AC-55-3S-GA MTR-AC-55-3S-GB	MTR-AC-70-3S-AA MTR-AC-70-3S-AB	MTR-AC-70-3S-GA ²⁾ MTR-AC-70-3S-GB ²⁾	→ Page
Motor controller						
SEC-AC-305	■	■	■	■	■	5 / 2.2-38
SEC-AC-508	–	–	–	–	–	
Motor cable						
KMTR-AC-...	■	■	■	■	■	5 / 2.2-31
KRES-AC-...	■	■	■	■	■	
KSEC-AC-...	■	■	■	■	■	
Motor flange						
MTR-FL28/30-AC40	■	–	–	–	–	5 / 2.2-36
MTR-FL28-AC55	–	■	–	–	–	
MTR-FL30-AC55	–	■	–	–	–	
MTR-FL44-AC55	–	■	–	–	–	
MTR-FL44-PL60	–	–	■	–	–	
MTR-FL44-AC70	–	–	–	■	■	
MTR-FL64-AC70	–	–	–	–	■	
Electro-mechanical drives						
DGE-8-...-ZR	■	–	–	–	–	5 / 2.1-2
DGE-12-...-ZR	■	■	–	–	–	
DGE-18-...-ZR	–	■	–	–	–	
DGE-25-...-ZR	–	–	–	■	■	
DGE-25-...-RF	–	–	■	■	■	5 / 2.1-2
DGEA-18-...-ZR	–	–	■	–	–	5 / 2.1-90
DGEA-25-...-ZR	–	–	–	–	■	
DGE-18-...-SP	■	■	–	–	–	5 / 2.1-118
DGE-25-...-SP	–	■	–	–	–	
DGE-40-...-SP	–	–	–	■	–	

- 1) The motor flange MTR-FL30-AC55 must be used in combination with the axis DGE-12-...-ZR
The motor flange MTR-FL28-AC55 must be used in combination with the axis DGE-18-...-SP
The motor flange MTR-FL44-AC55 must be used in combination with the axis DGE-18-...-ZR or DGE-25-...-SP
- 2) The motor flange MTR-FL44-AC70 must be used in combination with the axis DGE-25-...-ZR or DGE-25-...-RF
The motor flange MTR-FL64-AC70 must be used in combination with the axis DGEA-25-...-ZR

Servo motors MTR-AC

Selection aid and type codes

Permissible combinations					
Motor	MTR-AC-100-3S-AA MTR-AC-100-3S-AB	MTR-AC-100-3S-GA ¹⁾ MTR-AC-100-3S-GB ¹⁾	MTR-AC-100-5S-AA MTR-AC-100-5S-AB	MTR-AC-100-5S-GA ²⁾ MTR-AC-100-5S-GB ²⁾	→ Page
Motor controller					
SEC-AC-305	■	■	-	-	5 / 2.2-38
SEC-AC-508	-	-	■	■	
Motor cable					
KMTR-AC-...	■	■	■	■	5 / 2.2-31
KRES-AC-...	■	■	■	■	
KSEC-AC-...	■	■	■	■	
Motor flange					
MTR-FL64-AC100	■	■	■	■	5 / 2.2-36
MTR-FL118-AC100	-	■	-	■	
Electro-mechanical drives					
DGE-40-...-ZR	■	■	■	■	5 / 2.1-2
DGE-63-...-ZR	-	-	-	■	
DGE-40-...-RF	-	■	■	-	5 / 2.1-2
DGE-63-...-RF	-	■	-	■	
DGEA-40-...-ZR	-	-	-	■	5 / 2.1-90
DGE-40-...-SP	■	-	-	-	5 / 2.1-118
DGE-63-...-SP	-	-	■	-	

- 1) The motor flange MTR-FL64-AC100 must be used in combination with the axis DGE-40-...-ZR or DGE-40-...-RF
The motor flange MTR-FL118-AC100 must be used in combination with the axis DGE-63-...-RF
- 2) The motor flange MTR-FL64-AC100 must be used in combination with the axis DGE-40-...-ZR
The motor flange MTR-FL118-AC100 must be used in combination with the axis DGE-63-...-ZR, DGE-63-...-RF or DGEA-40-...-ZR

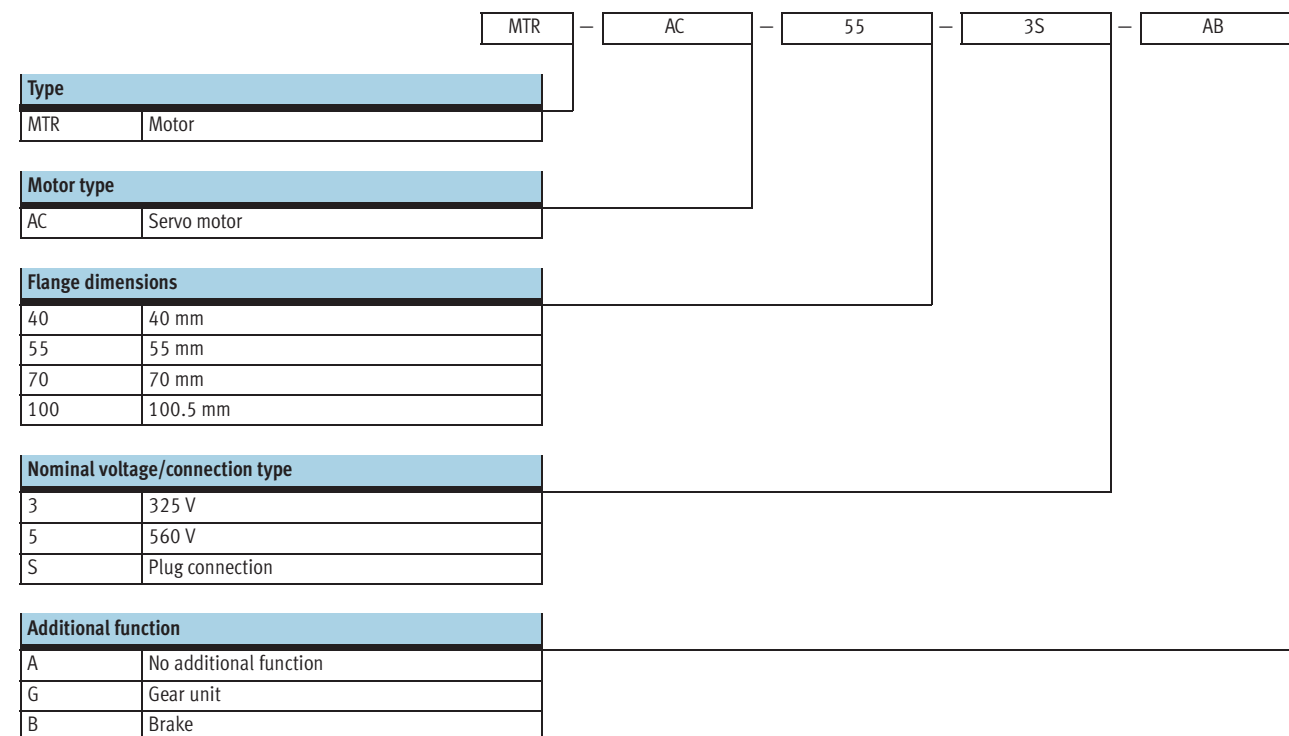

Servo motors MTR-AC

Technical data

FESTO



General electrical data		MTR-AC-40-3S-...	MTR-AC-55-3S-...	MTR-AC-70-3S-...	MTR-AC-100-3S-...	MTR-AC-100-5S-...
Nominal voltage	[V]	325	325	325	325	560
Nominal current, motor	[A]	0.67	1.4	4.3	5.0	4.3
Continuous current at standstill	[A]	0.8	2.15	5.07	6.7	8.43
Peak current	[A]	3.2	6.4	10	20	16
Motor constant	[Nm/A]	0.357	0.457	0.32	0.711	1.49
Winding resistance	[Ω]	34.8	9.6	1.91	1.5	1.205
Winding inductance	[mH]	13.3	9.25	3.3	4.629	5.204
Nominal power	[W]	150	468	913	1417	2396
Voltage, brake	[V DC]	24	24	24	24	24
Power, brake	[W]	6	11	11	13	13

General mechanical data		MTR-AC-40-3S-...	MTR-AC-55-3S-...	MTR-AC-70-3S-...	MTR-AC-100-3S-...	MTR-AC-100-5S-...
Torque at standstill	[Nm]	0.27	0.98	1.64	4.74	12.53
Nominal torque	[Nm]	0.24	0.66	1.4	3.53	6.36
Nominal speed	[rpm]	6000	6800	6250	4300	3600
Peak torque	[Nm]	1	2.8	3.1	12.2	23
Maximum speed	[rpm]	8100	8090	11640	5320	4550
Drive mass moment of inertia	[kg cm ²]	0.0453	0.2	0.4	2.6	6.8

Mechanical data – Motors without gear unit/without brake		MTR-AC-40-3S-AA	MTR-AC-55-3S-AA	MTR-AC-70-3S-AA	MTR-AC-100-3S-AA	MTR-AC-100-5S-AA
Radial shaft load ¹⁾	[N]	82	150	150	300	500
Axial shaft load	[N]	12	75	75	150	150
Product weight	[kg]	0.67	1.5	2.0	4.68	9.1

Mechanical data – Motors without gear unit/with brake		MTR-AC-40-3S-AB	MTR-AC-55-3S-AB	MTR-AC-70-3S-AB	MTR-AC-100-3S-AB	MTR-AC-100-5S-AB
Mass moment of inertia, brake	[kg cm ²]	0.001	0.06	0.1	0.54	0.54
Holding torque, brake	[Nm]	0.4	0.9	1.5	6	6
Radial shaft load ¹⁾	[N]	82	150	150	300	500
Axial shaft load	[N]	12	75	75	150	150
Product weight	[kg]	0.735	1.7	2.2	5.24	9.7

1) Relative to shaft centre

Servo motors MTR-AC

Technical data

FESTO

Mechanical data – Motors with gear unit/without brake					
		MTR-AC-55-3S-GA	MTR-AC-70-3S-GA	MTR-AC-100-3S-GA	MTR-AC-100-5S-GA
Mass moment of inertia, gear unit	[kg cm ²]	0.093	0.2	0.6	0.6
Gear reduction ratio	–	4:1	4:1	4:1	4:1
Gear unit efficiency	–	0.95	0.98	0.98	0.98
Torsional backlash	[arcmin]	20	3	3	3
Torsional resistance	[Nm/arcmin]	< 1.5	< 2.3	< 4.5	< 4.5
Radial shaft load ¹⁾	[N]	500	1200	4000	4000
Axial shaft load	[N]	600	4000	9000	9000
Product weight	[kg]	2.4	5.0	8.98	13.4

Mechanical data – Motors with gear unit/with brake					
		MTR-AC-55-3S-GB	MTR-AC-70-3S-GB	MTR-AC-100-3S-GB	MTR-AC-100-5S-GB
Mass moment of inertia, gear unit	[kg cm ²]	0.093	0.2	0.6	0.6
Gear reduction ratio	–	4:1	4:1	4:1	4:1
Gear unit efficiency	–	0.95	0.98	0.98	0.98
Torsional backlash	[arcmin]	20	3	3	3
Torsional resistance	[Nm/arcmin]	< 1.5	< 2.3	< 4.5	< 4.5
Mass moment of inertia, brake	[kg cm ²]	0.06	0.1	0.54	0.54
Holding torque	[Nm]	0.9	1.5	6	6
Radial shaft load ¹⁾	[N]	500	1200	4000	4000
Axial shaft load	[N]	600	4000	9000	9000
Product weight	[kg]	2.6	5.2	9.54	14

1) Relative to shaft centre

Operating and environmental conditions						
		MTR-AC-40-3S-...	MTR-AC-55-3S-...	MTR-AC-70-3S-...	MTR-AC-100-3S-...	MTR-AC-100-5S-...
Rotary position generator		Resolver				
Resolver type		Transmitter/1pp				
Temperature sensor		PTC				
Insulation protection class to DIN EN 60034		F				
Protection class	without gear unit	IP54		IP54		
	with gear unit	–	IP43			
UL certification		File no: E245 537				
CE marking symbol (see conformity declaration)		As per EU EMC directive				
Ambient temperature	[°C]	–40 ... +40 (to 130 °C with derating)				
Storage temperature	[°C]	–10 ... +60				
Relative air humidity (non-condensing)	[%]	Max. 90				

Technical data for cables					
		Cable composition	Ambient temperature	Suitable for chain link trunking	Protection class, motor plug
KMTR-AC-...		4 x 0.25 mm ² + 4 x 1 mm ² , screened	–40 ... +125 °C	■	IP54
KRES-AC-...		3 x (2 x 0.14 mm ²) + 2 x 0.5 mm ² , screened	–40 ... +125 °C	■	IP54

Servo motors MTR-AC

Technical data



Torque M as a function of n (r.p.m.)

MTR-AC-40-...

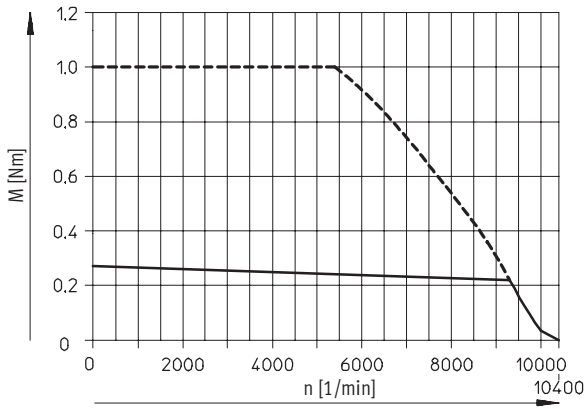

MTR-AC-55-...

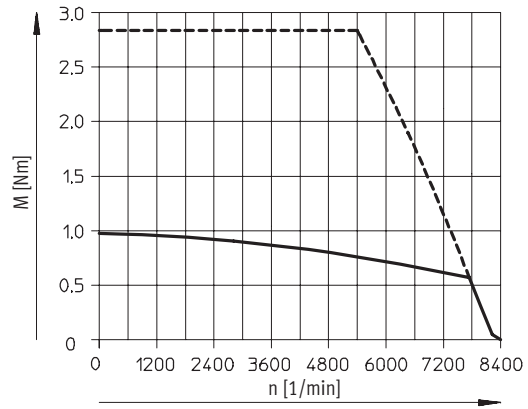

MTR-AC-70-...

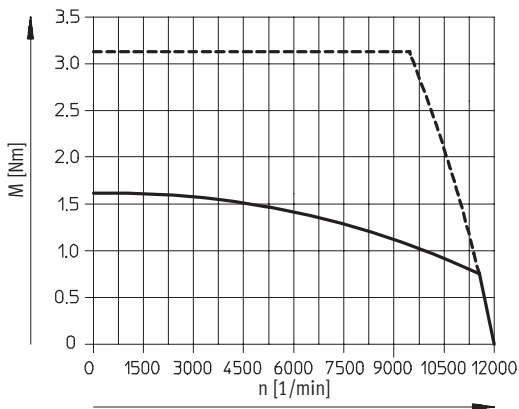

MTR-AC-100-3S-...

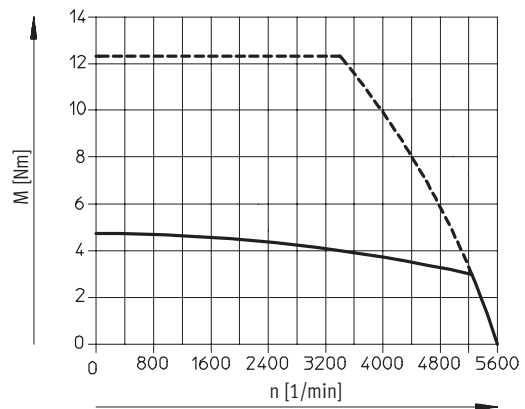

- Nominal torque
- - - Peak torque

Servo motors MTR-AC

Technical data

MTR-AC-100-5S-...

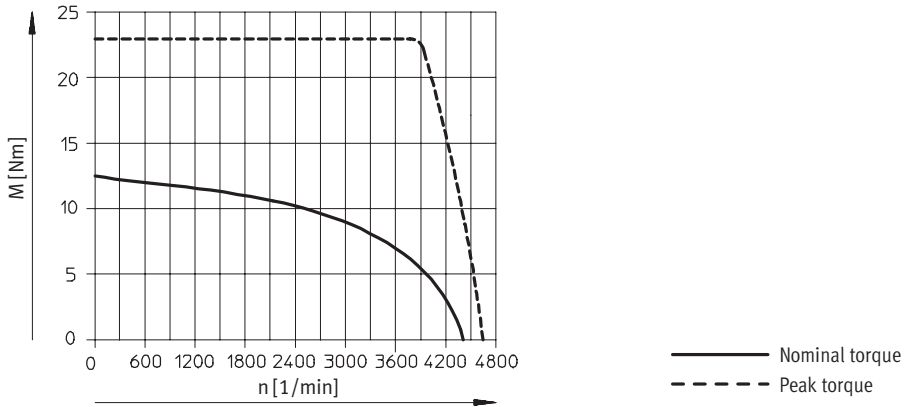

Note

Characteristic curves apply to motors without gear unit. The gear unit data must be taken into consideration for motors with gear unit.

Example:
Nominal torque for motor MTR-AC-55-3S-... at a nominal 6800 rpm

without gear unit:
Nominal torque = 0.66 Nm
(see characteristic curve)

with gear unit:
Gear reduction ratio = 4:1
Gear unit efficiency = 0.95
Nominal rpm = 6800 / 4 = 1700
Nominal torque = 0.66 Nm x 4 x 0.95 = 2.5 Nm

Servo motors MTR-AC

Technical data



Dimensions

Download CAD data → www.festo.com/en/engineering

Motors

MTR-AC-40

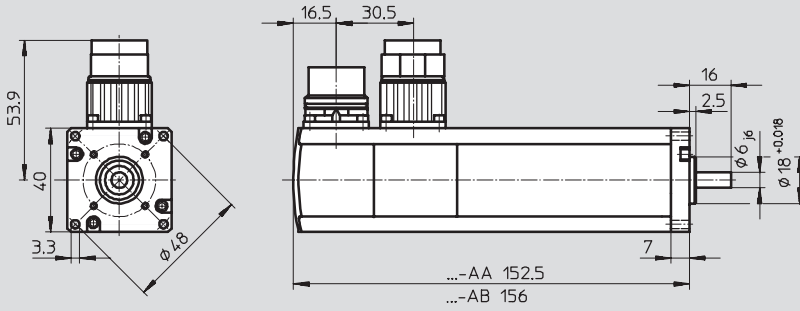

MTR-AC-55 ... 100

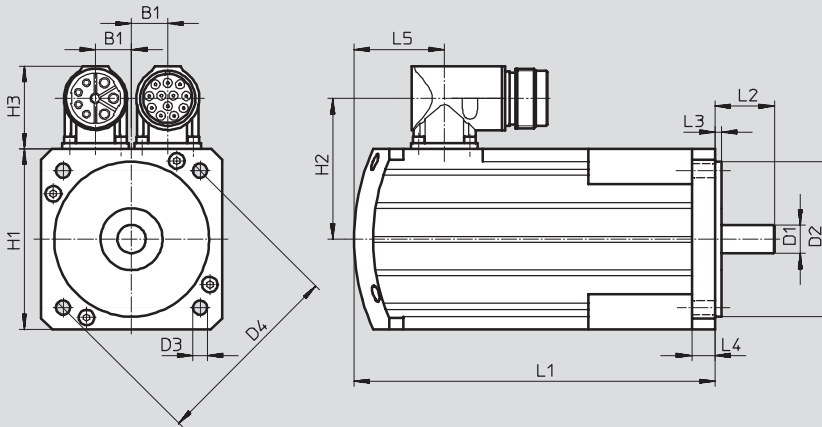

MTR-AC-55/70-3S-GA

MTR-AC-55/70-3S-GB

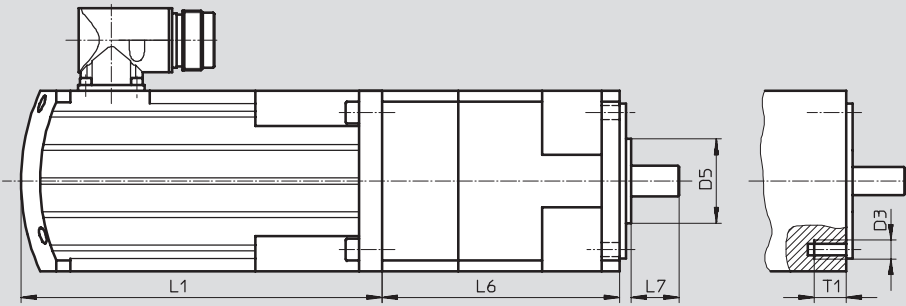

Servo motors MTR-AC

Technical data



Type	B1	D1	D2	D3	D4	D5	H1	H2
		∅	∅	∅	∅			
MTR-AC-55-3S-AA	14	9	40	5.5	63	-	55	47
MTR-AC-55-3S-AB		+0.01/+0.001	+0.011/-0.005					
MTR-AC-55-3S-GA	14	11	40	M5	52	17	60	47
MTR-AC-55-3S-GB		-0.018	-0.025					
MTR-AC-70-3S-AA	14	11	60	5.5	75	-	70	54.5
MTR-AC-70-3S-AB		+0.012/+0.001	+0.012/-0.007					
MTR-AC-70-3S-GA	14	12	60	5.5	75	32.5	70	54.5
MTR-AC-70-3S-GB		+0.012/+0.001	+0.013/-0.009					
MTR-AC-100-3S-AA	19	19	95	9	115	-	100.5	70
MTR-AC-100-3S-AB		+0.015/+0.002	+0.019/-0.009					
MTR-AC-100-3S-GA	19	24	95	9	115	-	100.5	70
MTR-AC-100-3S-GB		+0.015/+0.002	+0.013/-0.009					
MTR-AC-100-5S-AA	19	19	95	9	115	-	100.5	70
MTR-AC-100-5S-AB		+0.015/+0.002	+0.013/-0.009					
MTR-AC-100-5S-GA	19	24	95	9	115	-	100.5	70
MTR-AC-100-5S-GB		+0.015/+0.002	+0.019/-0.009					

Type	H3	L1	L2	L3	L4	L5	L6	L7	T1
MTR-AC-55-3S-AA	32.5	147.4	20	2.5	9	31	-	-	-
MTR-AC-55-3S-AB		164.4				±0.05			
MTR-AC-55-3S-GA	32.5	147.4	35	3	-	31	106.5	30	8
MTR-AC-55-3S-GB		164.4	±0.7	±0.2	48	±0.2			
MTR-AC-70-3S-AA	32.5	139.8	22.7	2.5	9	35	-	-	-
MTR-AC-70-3S-AB		161.8				-0.1			
MTR-AC-70-3S-GA	32.5	139.8	23	4	7	35	115.5	19	-
MTR-AC-70-3S-GB		161.8	±0.4	-0.1	57	±0.8/-0.5		±0.3	
MTR-AC-100-3S-AA	32.5	171.2	40	3	9.8	37.9	-	-	-
MTR-AC-100-3S-AB		192.3				59			
MTR-AC-100-3S-GA	32.5	241.6	40	3	6.8	37.9	-	-	-
MTR-AC-100-3S-GB		262.7				59			
MTR-AC-100-5S-AA	32.5	273.2	40	3	9.8	37.9	-	-	-
MTR-AC-100-5S-AB		294.3				59			
MTR-AC-100-5S-GA	32.5	344.2	40	3	6.8	37.9	-	-	-
MTR-AC-100-5S-GB		365.3				59			

Servo motors MTR-AC

Technical data



Dimensions Download CAD data → www.festo.com/en/engineering

Motor flange
MTR-FL28/30-AC40 MTR-FL28-AC55

MTR-FL30-AC55/MTR-FL44-AC55/MTR-FL44-AC70 MTR-FL44-PL60

MTR-FL64-AC70 / MTR-FL64-AC100 MTR-FL118-AC100

Type	B1	B2	B3	B4	B5	B6	D1 ∅	D2 ∅ H7	D3 ∅	D4 ∅	D5 ∅	D6 ∅	D7	D8	D9 H7	L1	T1	T2	W1
MTR-FL28/30-AC40	40	-	-	-	21	-	18 ^{F7}	30	15.5	48	30	26	M3	M3	28	10.5	2.5	1.9	30
MTR-FL28-AC55	55	-	-	-	-	-	40 ^{F7}	28	17	63	30	21	M5	M3	-	10.5	1.8	2.8	-
MTR-FL30-AC55	55	-	-	-	-	-	40 ^{F7}	30	16	63	26.2	-	M5	M3	-	11	2.3	2.8	30
MTR-FL44-AC55	55	-	-	-	-	-	40 ^{F7}	44	32	63	38	-	M5	M4	-	10.5	2.3	2.7	35
MTR-FL44-PL60	60	-	-	-	-	-	40 ^{G7}	44	32	70	38	52	M4	M5	-	20	2.5	3.2	-
MTR-FL44-AC70	70	-	-	-	-	-	60 ^{F7}	44	32	75	38	-	M5	M4	-	13.5	2.5	5.2	35
MTR-FL64-AC70	70	-	-	-	-	-	60 ^{F7}	64	47	75	56	-	M5	M6	-	16	3.8	4.2	-
MTR-FL64-AC100	100	-	-	-	-	-	95 ^{F7}	64	48	115	56	-	M8	M6	-	21	3.8	3.3	-
MTR-FL118-AC100	100	105	50	49	84	21.5	95 ^{F7}	118	76	-	-	-	M8	M8	-	25	4.8	3.3	-

Servo motors MTR-AC

Technical data

FESTO

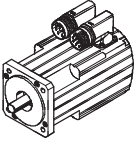
Ordering data – Servo motors MTR-AC-...			
		Part No.	Type
	MTR-AC-40-...	540 299	MTR-AC-40-3S-AA
		540 300	MTR-AC-40-3S-AB
	MTR-AC-55-...	526 723	MTR-AC-55-3S-AA
		526 724	MTR-AC-55-3S-AB
	MTR-AC-55-...	526 725	MTR-AC-55-3S-GA
		526 726	MTR-AC-55-3S-GB
		526 727	MTR-AC-70-3S-AA
	MTR-AC-70-...	526 728	MTR-AC-70-3S-AB
		526 729	MTR-AC-70-3S-GA
		526 730	MTR-AC-70-3S-GB
	MTR-AC-100-3S-...	526 731	MTR-AC-100-3S-AA
		526 732	MTR-AC-100-3S-AB
		526 733	MTR-AC-100-3S-GA
		526 734	MTR-AC-100-3S-GB
	MTR-AC-100-5S-...	526 735	MTR-AC-100-5S-AA
		526 736	MTR-AC-100-5S-AB
		526 737	MTR-AC-100-5S-GA
		526 738	MTR-AC-100-5S-GB

Ordering data – Motor cables KMTR-AC-.../KRES-AC-.../KSEC-AC-...				
		Part No.	Type	Cable length
	Motor cable KMTR-AC-...	526 739	KMTR-AC-5	5 m
		526 740	KMTR-AC-10	10 m
		526 741	KMTR-AC-15	15 m
		526 742	KMTR-AC-X	X length (max. 25 m)
	Resolver cable KRES-AC-...	526 743	KRES-AC-5	5 m
		526 744	KRES-AC-10	10 m
		526 745	KRES-AC-15	15 m
		526 746	KRES-AC-X	X length (max. 25 m)
	Cable set KSEC-AC-...	526 747	KSEC-AC-5	5 m
		526 748	KSEC-AC-10	10 m
		526 749	KSEC-AC-15	15 m
		529 984	KSEC-AC-X	X length (max. 25 m)

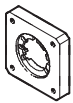
Ordering data – Motor flange MTR-FL-...			
		Part No.	Type
	MTR-FL28/30-...	540 301	MTR-FL28/30-AC40
	MTR-FL28-...	529 946	MTR-FL28-AC55
	MTR-FL30-...	534 807	MTR-FL30-AC55
	MTR-FL44-...	529 942	MTR-FL44-AC55
		529 943	MTR-FL44-AC70
		529 944	MTR-FL44-PL60
	MTR-FL64-...	529 945	MTR-FL64-AC70
		529 947	MTR-FL64-AC100
	MTR-FL118-...	529 949	MTR-FL118-AC100

Motor controllers SEC-AC, for servo motors

Key features

This controller is a servo controller and positioning controller in one. It is designed to complement the Festo servo motors MTR-AC.



Information on functionality

4 operating modes:

- Torque control (current regulation)
- RPM regulation
- Position control: positioning control
- Position control: synchronised operation (master-slave; electronic gear unit, etc.)

Special features:

- Stable and error-free switching between operating modes during operation is possible at any time

16 freely programmable record memories:

The following are freely adjustable:

- Position, absolute or relative
- Speed
- Acceleration
- Delay
- Step travel (change in speed during positioning)
- Activation of outputs during positioning

Stopping behaviour:

- If a limit switch is approached, the motor brakes using a preset ramp and stops in position control mode
- If release is deactivated during travel, the motor brakes using a preset ramp and stops at zero-torque when $n = 0$

Quick and easy commissioning by means of:

- User-friendly Windows PC software
- Optimised axis parameters for the complete range of axes offered by Festo
- Third-party motor support by means of automatic current control adjustment and resolver identification

Information on hardware

10 digital inputs, electrically isolated (12 ... 30 V):

- 4 inputs for record selection
- 1 start input for selected positioning record
- 2 inputs for limit switches: 1 of which can be configured as a reference switch, NC contact or NO contact jointly configurable
- 1 synchronisation input for synchronous operation
- 2 separate enabling inputs for output stage and controller release
- 1 high-speed input

5 digital outputs, electrically isolated (24 V external)

- 1 output for the message "Ready for operation"
- 1 output for the holding brake
- 3 programmable outputs

Optional with fieldbus interface

In a motor controller SEC-AC with Profibus-DP or CANopen, the master controller has access to all controller data. This open method of communication means that random travel requests can be transferred while the controller is running.

- Specify target position
- Setting/changing of speed
- Specify acceleration
- Set current limit
- Stop in response to external event

The master controller decides which of the four operating modes will be used. Querying various actual data such as

- current position
- current motor current/torque
- status of the digital inputs
- current following error

means that the sequence can be flexibly tailored to the positioning task at hand.

CANopen adaption takes place according to the specification DS 301/DSP 402. With the Profibus-DP interface, structured data blocks (depending on the operating mode) are used for communication. Festo provides appropriate program modules to assist in FST programming at no extra cost.

For the Simatic S7 controller with Profibus-DP Master, Festo offers a free software package, comprising a manual and an archived S7 project. For all other PLC controllers, the Profibus interface works with data fields optimised for the operating modes. All controller parameters are available.

Special features

Post-optimisation or use of third-party motors:

- Adjustable current limits not dependent on closed loop gain
- Automatic calculation of the number of paired poles of the motor
- Automatic current control optimisation

"plug and work" when using Festo axes with drive packages thanks to delivery of pre-tested, optimised parameters for all available combinations at no extra cost.



Motor controllers SEC-AC, for servo motors



Technical data

General electrical data		
	SEC-AC-305	SEC-AC-508
Nominal operating voltage V_{nominal} [V AC]	1 x 230 (-15 ... +20%)	3 x 400 (-15 ... +20%)
Mains frequency [Hz]	50 ... 60	
Current consumption at 24 V DC without brake [A]	Approx. 0.35	Approx. 0.45
Nominal power/peak power [VA]	1000/3000	4000/9000 at t_{max} 2s with additional fan
Link voltage [V DC]	Max. 340	Max. 680
Nominal current/peak current per phase [Aeff]	5/10	8/16
Max. peak current duration [s]	10	2
Integrated braking limiter incl. braking resistance [Ω]	100	150
Pulse power [kVA]	1.3	3.2
Setpoint inputs for rpm and current	2 separately programmable differential inputs ± 10 V, $R_i = 20 \text{ k}\Omega$, offset adjust ± 0.1 V, RS232 interface	
Monitor outputs (monitoring points)	2 analogue outputs with 8 bit resolution to X1 ± 10 V voltage output, short-circuit proof	
Logic inputs	10 digital inputs to the regulator and positioning controller, electrically isolated, 12 ... 30 V	
Logic outputs	5 digital outputs, of which 3 can be freely configured, electrically isolated, 24 V, 100 mA	
Serial interfaces	RS232	V24 interface: For programming and initial commissioning using a PC, and as an interface for any desired controllers. All device functions can be accessed via this interface (9600 ... 57600 bits/s)
	RS422 Output	Encoder simulation 1024 ppr as actual value feedback for rpm controller operation. As setpoint specification for downstream device during master-slave operation.
	RS422 Input	Encoder signal input 1024 ppr for rpm controller operation. As slave setpoint during master-slave operation.

Operating and environmental conditions		
	SEC-AC-305	SEC-AC-508
Ambient temperature [°C]	0 ... +50	
Weight [kg]	2.5	2.7
Protection class to DIN 40050, IEC 144	IP20	
Mains filter	Integrated	
CE marking symbol (see conformity declaration)	As per EU EMC directive	

Technical data – Profibus-DP		
	SEC-AC-305	SEC-AC-508
Fieldbus baud rate [MBaud]	12	
Communication profile	Operating mode-dependent data fields for Step7 via functional module	
Bus terminating resistor	Integrated	
Bus connection	Sub-D 9-pin (socket)	

Technical data – CANopen		
	SEC-AC-305	SEC-AC-508
Fieldbus baud rate [MBaud]	1	
Communication profile	DS 301/DSP 402	
Bus terminating resistor [Ω]	120, external	
Bus connection	Sub-D 9-pin (plug)	

Motor controllers SEC-AC, for servo motors

Technical data

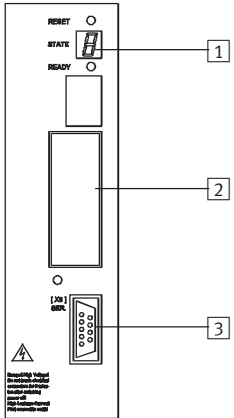

View of motor controller	Explanation of the interfaces
From above	
	<ul style="list-style-type: none"> 1 RS422 interface for sensor outputs 2 RS422 interface for sensor inputs 3 Interface for I/O connection
From the front	
	<ul style="list-style-type: none"> 1 7 segment display for status and error messages 2 For motor controllers with Profibus interface: space for Profibus interface 3 RS232 interface
From underneath	
	<ul style="list-style-type: none"> 1 Connection for resolver cable 2 Connection for motor cable 3 Connection for power supply

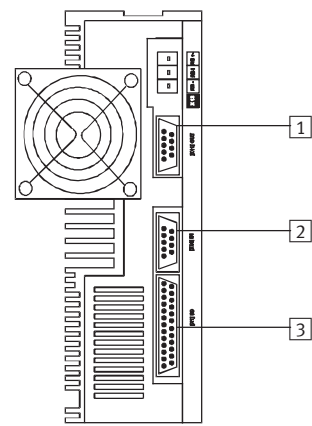

- 1 RS422 interface for sensor outputs
- 2 RS422 interface for sensor inputs
- 3 Interface for I/O connection

From the front	
----------------	--

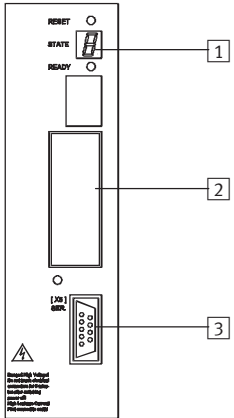

- 1 7 segment display for status and error messages
- 2 For motor controllers with Profibus interface: space for Profibus interface
- 3 RS232 interface

From underneath	
-----------------	--

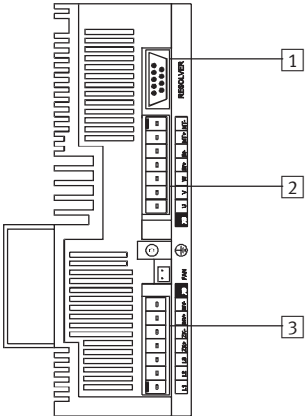

- 1 Connection for resolver cable
- 2 Connection for motor cable
- 3 Connection for power supply

Motor controllers SEC-AC, for servo motors

Technical data



Dimensions

Download CAD data → www.festo.com/en/engineering

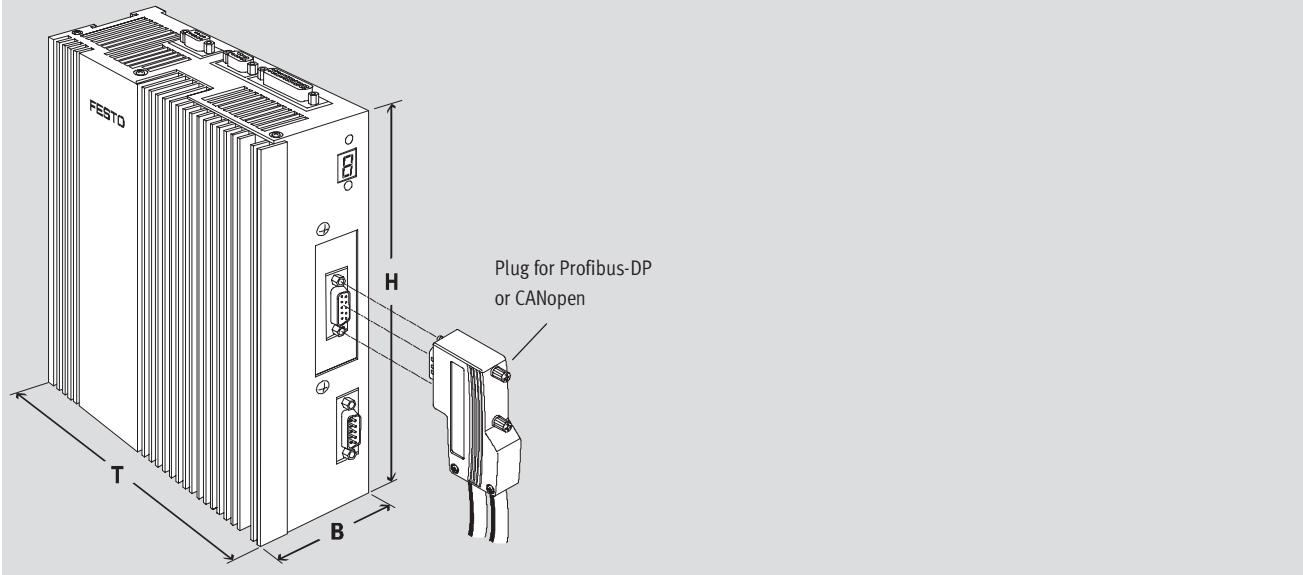

	H	B	T
SEC-AC-305	209	70	209
SEC-AC-508	232	90	209

Ordering data			
Brief description	Version	Part No.	Type
Motor controller without fieldbus connection	305	193 846	SEC-AC-305/P01
	508	193 847	SEC-AC-508/P01
Motor controller with fieldbus coupling for Profibus-DP	305	533 778	SEC-AC-305-PB-P01
	508	533 779	SEC-AC-508-PB-P01
Motor controller with fieldbus coupling for CANopen	305	533 781	SEC-AC-305-CO-P01
	508	533 782	SEC-AC-508-CO-P01

Included in the scope of delivery:

- Mounting rail
- Plug set (without fieldbus plug)
- Description for motor controller (installation and commissioning) in DE and EN
- Software for motor controller
 - Programming software
 - Parameterisation software: includes tested, optimised parameter sets for all motor axis combinations

Motor controllers SEC-AC, for servo motors

Accessories



Mains filter MRC-NF-1-BSM-BSC for motor controller SEC-AC-305

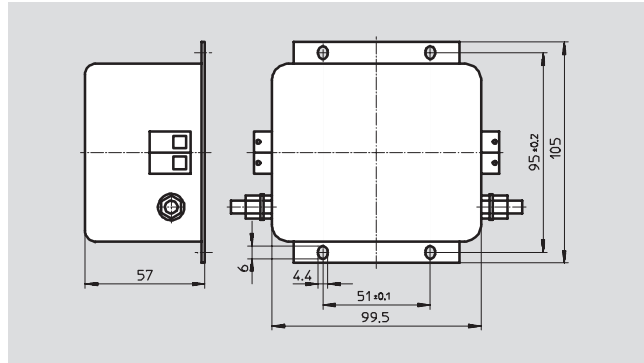

Dimensions and ordering data				
	Max. operating voltage [V AC]	Nominal current [A]	Max. leakage current [mA]	Power loss [W]
Mains filter	250	8	4.9	4.2

	Inductance [mH]	Resistance [MΩ]	Weight [g]	Part No.	Type
Mains filter	10	1	700	176 041	MRC-NF-1-BSM-BSC

Mains filter MRC-NF-3-BSM-BSC for motor controller SEC-AC-508

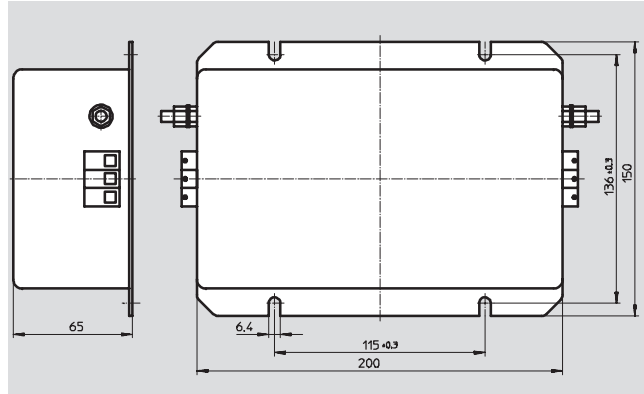

Dimensions and ordering data				
	Max. operating voltage [V AC]	Nominal current [A]	Max. leakage current [mA]	Power loss [W]
Mains filter	440	16	14.5	8

	Inductance [mH]	Resistance [MΩ]	Weight [g]	Part No.	Type
Mains filter	5.2	1.5	1800	176 042	MRC-NF-3-BSM-BSC

Motor controllers SEC-AC, for servo motors

Accessories





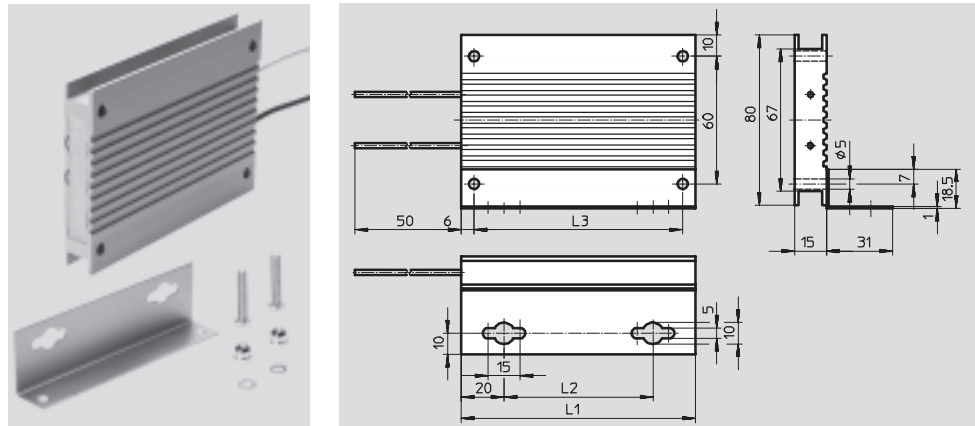

Brake resistor BRW



Dimensions and ordering data				
Size	Resistance value [Ω]	Nominal power [W]	Ambient temperature [°C]	Protection class
250	72±5%	100	0 ... +50	IP65
500	72±5%	200	0 ... +50	IP65

Size	L1	L2	L3 ±0.2	Weight [g]	Part No.	Type
250	110	70	98	280	538 940	BRW-250-072
500	216	176	204	550	538 941	BRW-500-072

General technical data for cables			
	Cable composition	Ambient temperature	Suitable for chain link trunking
Control cable for I/O connection KES-SEC-AC-...	5 x (2 x 0.25 mm ²) + 16 x 0.25 mm ² , screened	Flexible installation: -5 ... +80 °C Fixed installation: -30 ... +80 °C	■

Ordering data for accessories			Part No.	Type
	Control cable for I/O connection to any PLC controller		525 713	KES-SEC-AC-2,5
	Programming cable		160 786	PS1 ZK11
	Plug for Profibus-DP		533 780	FBS-SUB-9-WS-PB-K
	Plug for CANopen		533 783	FBS-SUB-9-WS-CO-K
	All user documentation on positioning in the languages: DE, EN, ES, FR, IT (on CD-ROM)		525 950	P.CD-POS
Description	Assembly and installation	DE	192 344	P.BE-SEC-AC-HW-DE
		EN	192 346	P.BE-SEC-AC-HW-EN
	Commissioning	DE	192 345	P.BE-SEC-AC-SW-DE
		EN	192 347	P.BE-SEC-AC-SW-EN
	Commissioning of Profibus-DP	DE	534 274	P.BE-SEC-AC-PB-DE
		EN	534 275	P.BE-SEC-AC-PB-EN
	Commissioning of CANopen	DE	534 276	P.BE-SEC-AC-CO-DE
EN		534 277	P.BE-SEC-AC-CO-EN	

Motor controllers SEC-AC, for servo motors

Technical data



Programming and commissioning software

The user-friendly PC parameter software for the product family SEC-AC-305 and SEC-AC-508 serves as

a tool for quick commissioning, complete and quick parameterisation,

optimisation and diagnosis of Festo motor controllers.

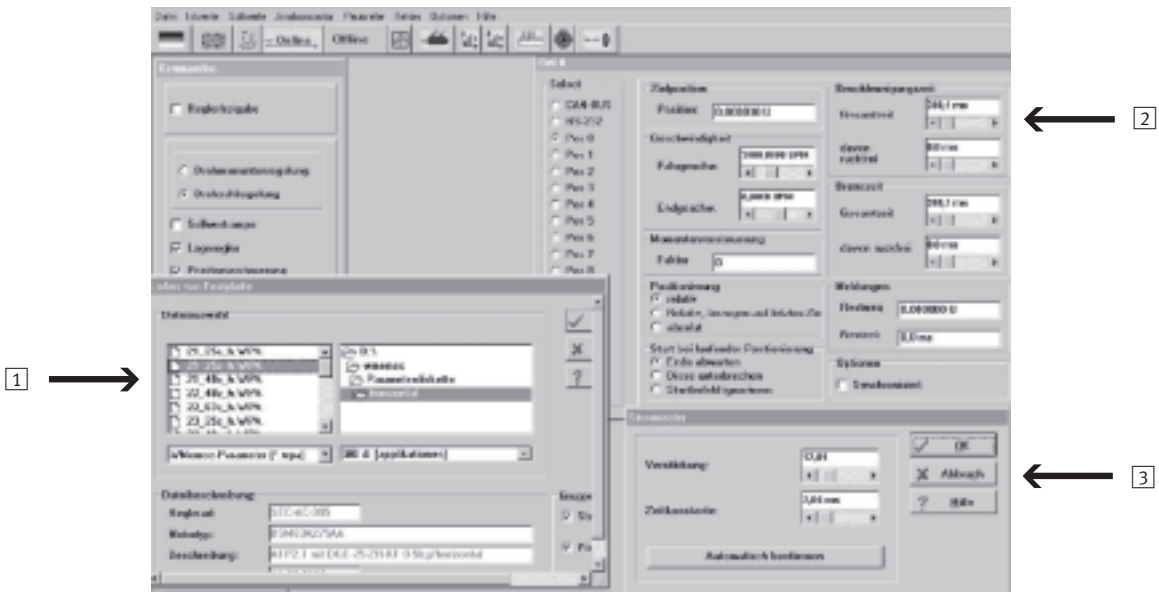

1 Controller parameters
Festo supplies the full set of SEC controller parameters for all combinations (linear axis, motor, gear unit, controller) on CD-ROM. Positions can be edited and approached as soon as the software has been loaded.

2 Positioning records
All 16 fixed positions and the temporary positions on the serial interface can be assigned individual parameters for dynamic movements. The parameter values can be copied from one to the other, considerably reducing the input time.

3 Adaption to third-party motors
The software automatically optimises the current control for unknown motors and also identifies the resolver position. This means that all servo motors with resolver feedback can be operated quickly and reliably using the controller SEC-AC.

Motor controllers SEC-AC, for servo motors

Technical data

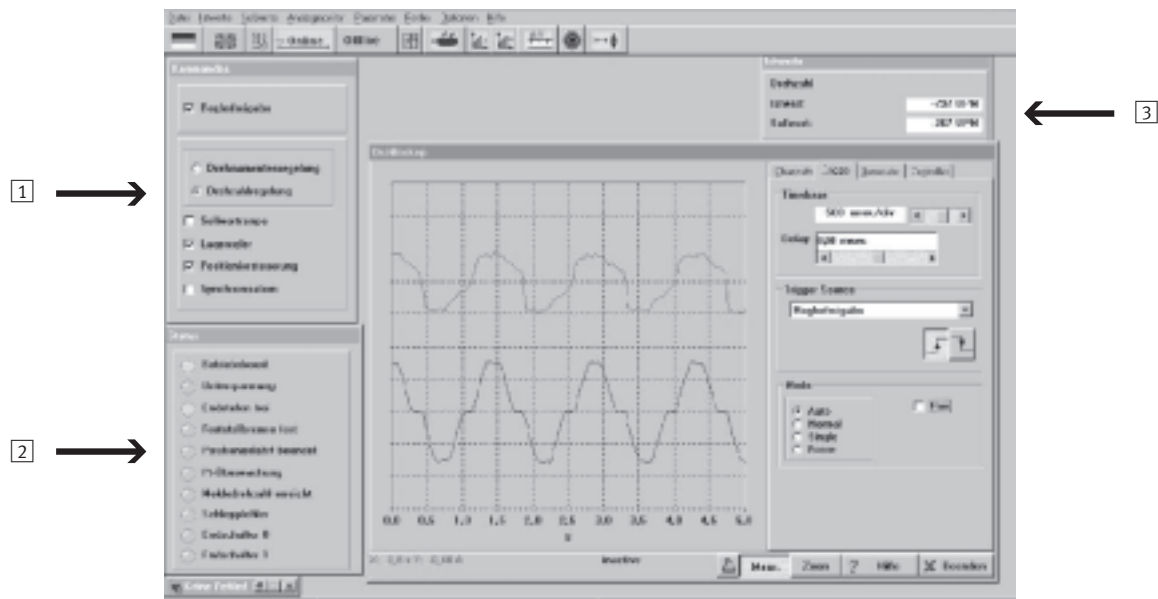

1 Operating modes
The operating modes can be freely selected and combined, thus facilitating the combination of positioning and synchronisation tasks.

2 Status signals
All device states can be indicated on the PC or output via the interface using red and green LEDs.

3 Actual values
The speed, torque, motor current, position actual values, power loss, etc. can either be displayed or read out via the interface.

