

Pressure regulators LR/LRS

Peripherals overview and type codes



Individual units
Pressure regulators
4.1

Peripherals overview

Pressure regulator LR

Pressure regulator LRS, lockable

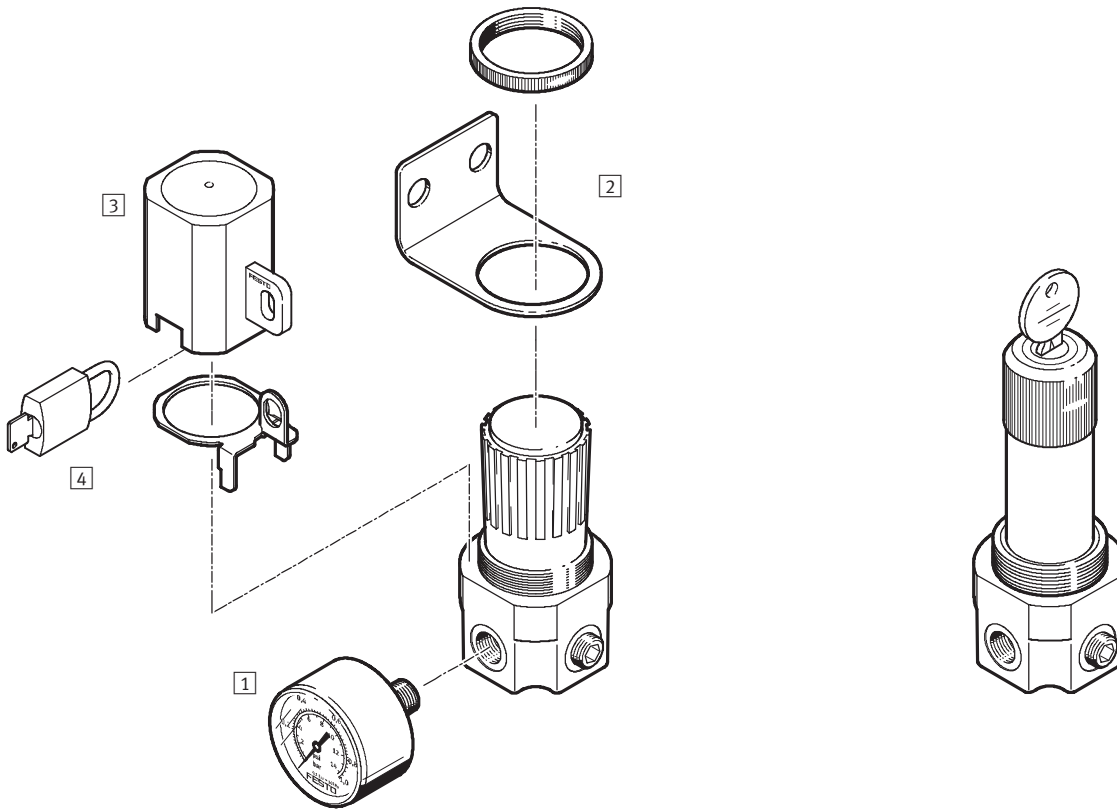

Mounting attachments and accessories	Brief description	→ Page
1 Pressure gauge MA	The pressure gauges measure pressure in bar and the psi display range or in MPa	3 / 4.8-1
2 Mounting bracket HR-D	For wall mounting	3 / 4.1-5
3 Regulator lock LRVS-G-1/8 with lock plate	Prevents unintentional, and in conjunction with an LRVS padlock, unauthorised adjustment of the rotary knob	3 / 4.1-5
4 Padlock LRVS-D	Accessory for LRVS	3 / 4.1-5

Type codes

LR	-	1/8	-	G	-	7
Service function						
LR	Pressure regulator					
LRS	Pressure regulator, lockable					
Pneumatic connection						
1/8	Thread G1/8					
Version code						
G	Version code					
Pressure regulation range						
7	0.5 ... 7 bar					
	0.5 ... 12 bar					

Pressure regulators LR/LRS

Technical data



Function

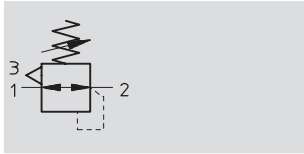

- - Flow rate
600 ... 700 l/min
- - Temperature range
-10 ... +80 °C
- - Input pressure
1 ... 20 bar

The pressure regulator is free of paint-wetting impairment substances.



- Larger design (brass housing)
- Good flow rate performance
- Precise diaphragm regulator
- Detenting regulator knob
- Identical mounting bracket to D series
- Suitable for input pressures up to $p_1 = 20$ bar
- 2 pressure regulation ranges: 0.5 ... 7 bar and 0.5 ... 12 bar

The pressure regulator maintains an essentially constant working pressure at the regulator outlet, regardless of pressure fluctuations in the compressed air network. The regulated operating pressure can be reduced by means of the built-in secondary exhaust, even without compressed air consumers.

The pressure regulator is available in two design variants:

- LR(S)-1/8-G for standard applications.
- LR(S)-1/8-G-7 for special individual cases, e.g. regulators in the pressure range up to 7 bar. This variant demonstrates optimal flow and control characteristics.

Panel mounting

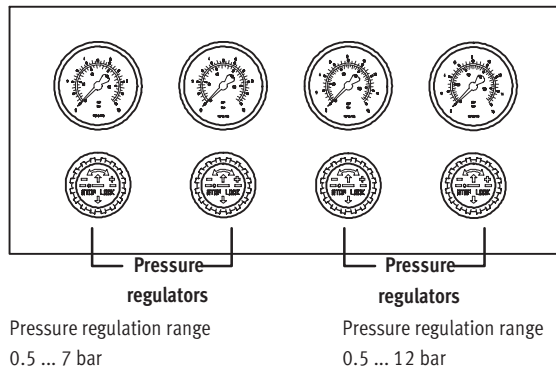

General technical data		
Type	LR(S)-1/8-G	LR(S)-1/8-G-7
Pneumatic connection	G1/8	
Operating medium	Filtered compressed air, lubricated or unlubricated (grade of filtration $\leq 40 \mu\text{m}$)	
Design	Input pressure compensated diaphragm pressure regulator with secondary exhaust	
Type of mounting	Via accessories	
Mounting position	Front panel mounting, installation hole $\varnothing 36.5$ mm	
Max. hysteresis [bar]	0.2	
Input pressure [bar]	1 ... 20	
Pressure regulation range [bar]	0.5 ... 12	0.5 ... 7

Standard nominal flow rate ¹⁾ q_{nN} [l/min]	
Pressure regulation range 0.5 ... 7 bar	700
Pressure regulation range 0.5 ... 12 bar	600

1) With 10 bar input pressure, 6 bar working pressure and $\Delta p = 1$ bar.

Pressure regulators LR/LRS

Technical data



Ambient conditions		
Ambient temperature	[°C]	-10 ... +80
Corrosion resistance	CRC ¹⁾	2

1) Corrosion resistance class 2 according to Festo standard 940 070
 Components requiring moderate corrosion resistance. Externally visible parts with primarily decorative surface requirements which are in direct contact with a surrounding industrial atmosphere or media such as cooling or lubricating agents.

Weights [g]		
	LR	LRS
Pressure regulator	320	420

Materials

Sectional view

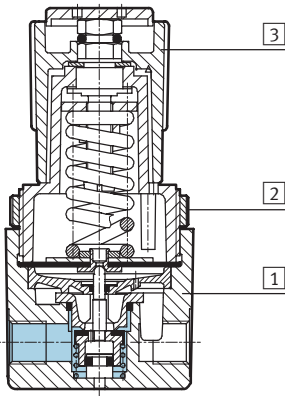

Pressure regulator	
1	Housing Brass
2	Knurled nut Aluminium
3	Rotary knob LR: Polyacetate LRS: Aluminium
-	Seals Nitrile rubber

Individual units
Pressure regulators

4.1

Primary pressure compensation – Primary pressure p₁ as a function of output pressure p₂

LR(S)-1/8-G(-7)

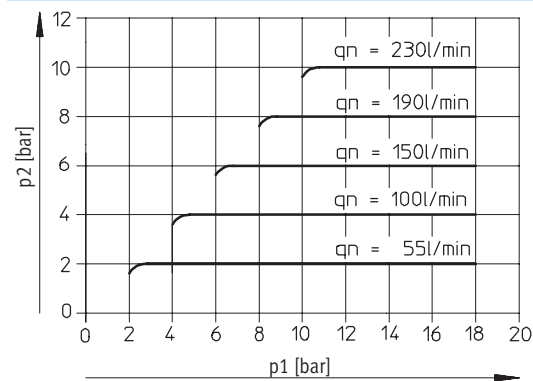

Secondary venting – Output pressure p₂ as a function of standard flow rate q_n

LR(S)-1/8-G(-7)

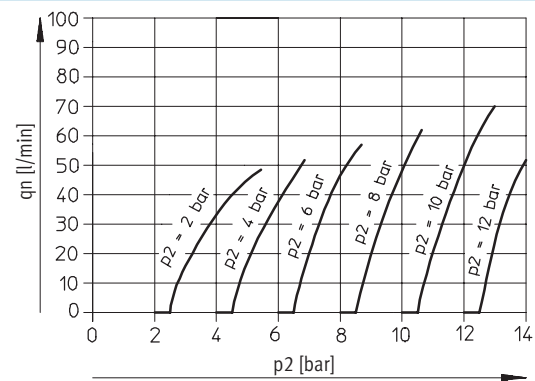

Pressure regulators LR/LRS

Technical data



Standard flow rate q_n as a function of the output pressure p_2

LR(S)-1/8-G

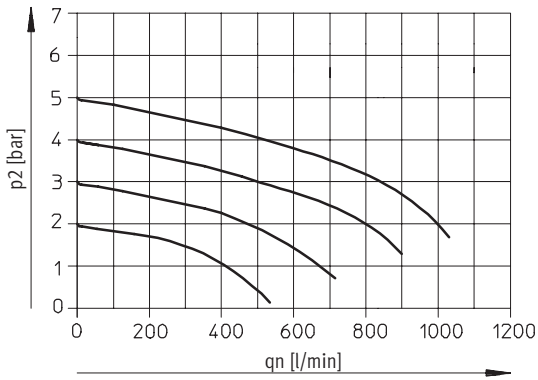

Primary pressure $p_1 = 7$ bar

LR(S)-1/8-G-7

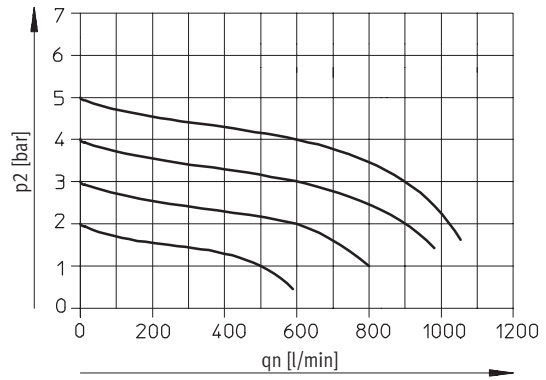

Primary pressure $p_1 = 7$ bar

LR(S)-1/8-G

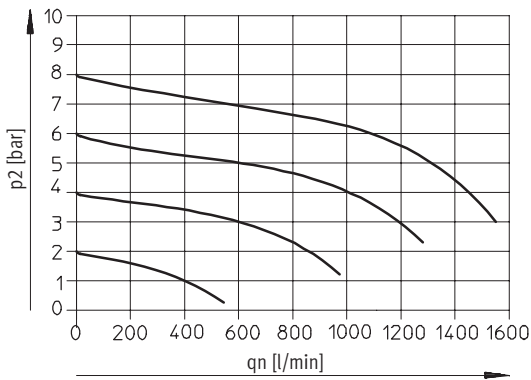

Primary pressure $p_1 = 10$ bar

LR(S)-1/8-G-7

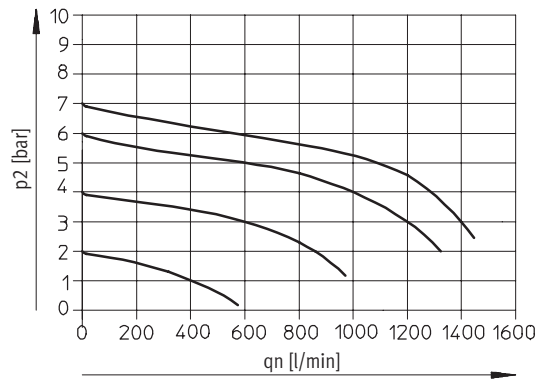

Primary pressure $p_1 = 10$ bar

LR(S)-1/8-G

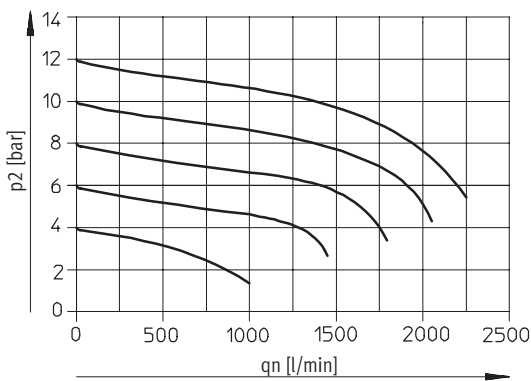

Primary pressure $p_1 = 14$ bar

LR(S)-1/8-G-7

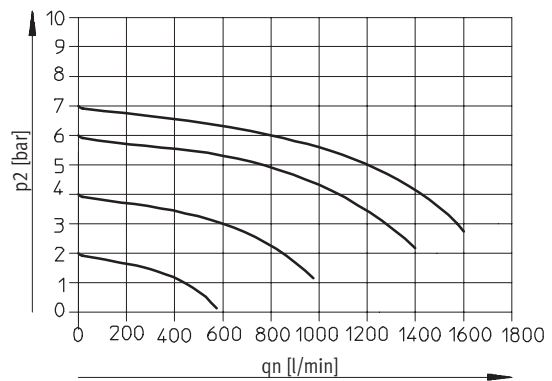

Primary pressure $p_1 = 14$ bar

Pressure regulators LR/LRS

Technical data



Individual units
Pressure regulators
4.1

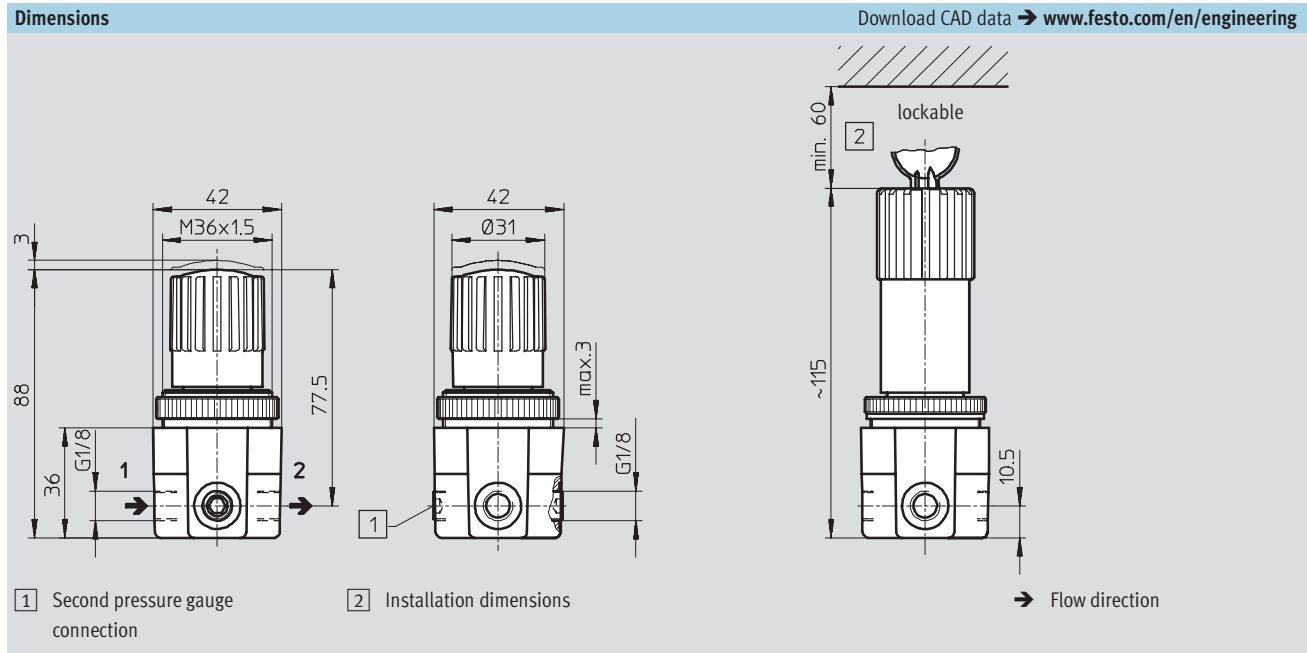

Ordering data				
Connection	Pressure regulation range 0.5 ... 7 bar		Pressure regulation range 0.5 ... 12 bar	
	Part No.	Type	Part No.	Type
G $\frac{1}{8}$	159 506	LR- $\frac{1}{8}$ -G-7	159 505	LR- $\frac{1}{8}$ -G
lockable				
G $\frac{1}{8}$	194 695	LRS- $\frac{1}{8}$ -G-7	194 694	LRS- $\frac{1}{8}$ -G

Pressure regulators LR/LRS

Accessories



Mounting bracket HR-D for wall mounting

Material:
Galvanised steel

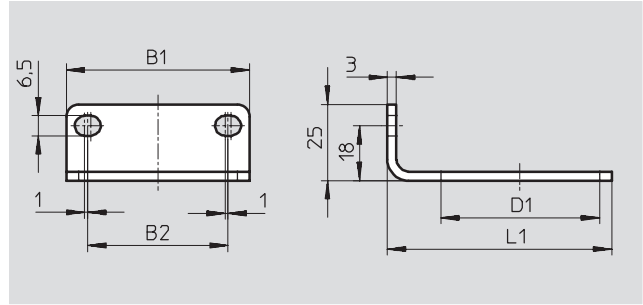

Ordering data						
Type	B1	B2	D1	L1	Part No.	Type
Mounting bracket	42	28	36	57.5	164 936	HR-D-MINI

Regulator lock LRVS

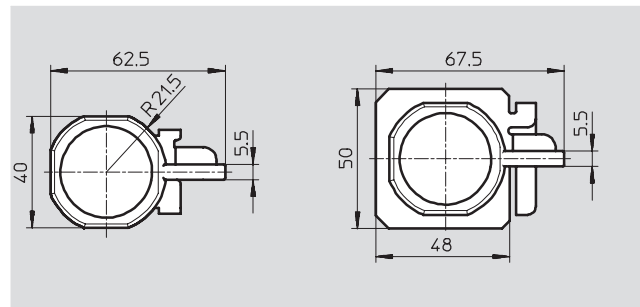

Ordering data				
	Connection	Weight [g]	Part No.	Type
Regulator lock	G1/8	36	196 080	LRVS-G-1/8

Padlock LRVS-D

Material:
Housing: Brass

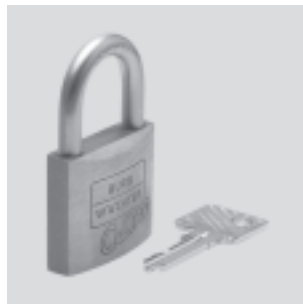

Ordering data			
	Weight [g]	Part No.	Type
Padlock	120	193 786	LRVS-D

Individual units
Pressure regulators

4.1