

- Economical and versatile
- Self-centring
- Variable gripping action

Parallel grippers HGP

Key features



Handling units
Parallel grippers

7.5

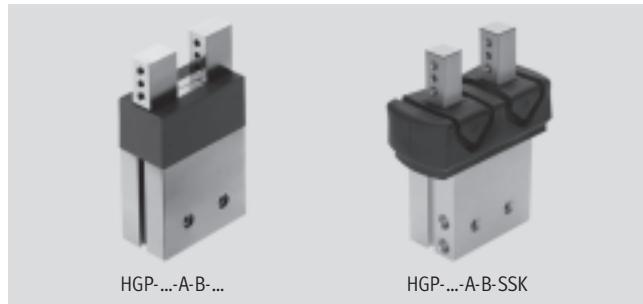

At a glance

- Double-acting piston drive
- Self-centring
- Variable gripping action:
 - External/internal gripping
- Versatility thanks to externally adaptable gripper fingers
- Wide range of options for mounting on drive units
- High gripping force and compact size
- Max. repetition accuracy
- Gripping force retention
- Internal fixed flow control
- With protective dust cap for use in dusty environments (protection class IP54)
- Sensor technology:
 - Adaptable proximity sensors on the small grippers
 - Integral proximity sensors for medium and large grippers



Gripper selection software
www.festo.com/en/engineering

Mounting options for external gripper fingers (customer-specific)

- 1 Parallel gripper
- 2 External gripper fingers
- 3 Mounting screws
- 4 Centring pins

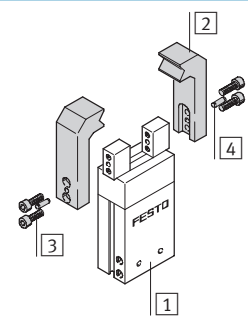

With protective dust cap

The sizes 16 and 25 can be adapted for use in dusty environments. They fulfil the requirements for protection class IP54. The technical data corresponds to the data for parallel gripper HGP without protective dust cap.



Note
 Grippers should always be used with exhaust air flow control. They are not suitable for the following, or for similar applications:

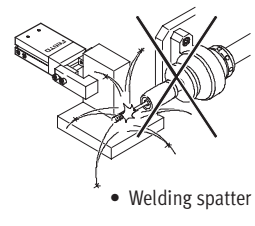
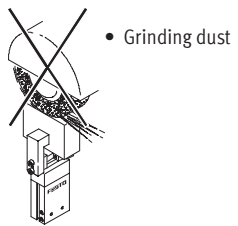
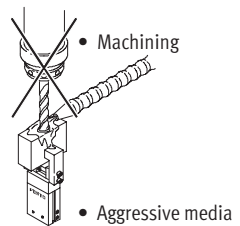

Parallel grippers HGP

Peripherals overview and type codes

Peripherals overview

HGP-06

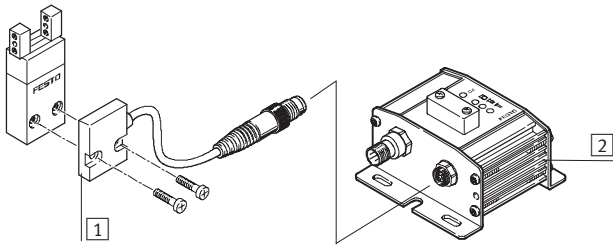

HGP-10 ... 35

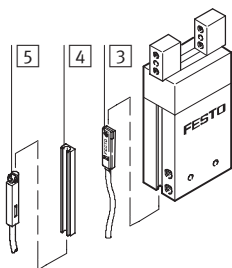

System product for handling and assembly technology

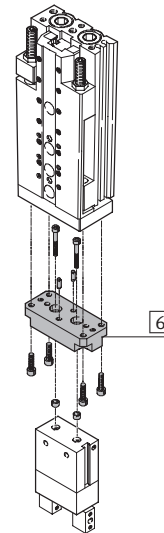

Accessories			
Type	Brief description	→ Page	
1	Position sensor SMH-S1 Adaptable and integratable sensor technology, for sensing the piston position	1 / 7.5-13	
2	Evaluation unit SMH-AE1 For position sensor SMH-S1	1 / 7.5-13	
3	Proximity sensor SME/SMT-8 For sensing the piston position	1 / 7.5-14	
4	Bondable sensor rail HGP-SL Allows the use of proximity sensors SME/SMT-10	1 / 7.5-13	
5	Proximity sensor SME/SMT-10 For sensing the piston position	1 / 7.5-15	
6	– Drive/gripper connections	Volume 5	

Type codes

Type		Size		Position sensing		Generation		Gripping force retention		Protective dust cap	
HGP	Parallel gripper	16		A		B		G1		SSK	
HGP	Parallel gripper			A	For proximity sensing			G1	Open		
						B	B series				
								G1	Open		
								G2	Closed		
										SSK	Protective dust cap

Parallel grippers HGP

Technical data



Function

Double-acting

HGP-06-A, HGP-...-A-B

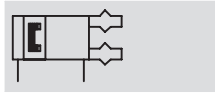

⌀ - Size
6 ... 35 mm

┆ - Stroke
4 ... 25 mm

Variants

- With gripping force retention...
... open HGP-...-G1
... closed HGP-...-G2
- With protective dust cap



www.festo.com/en/Spare_parts_service
Wearing parts kits
➔ 1 / 7.5-12

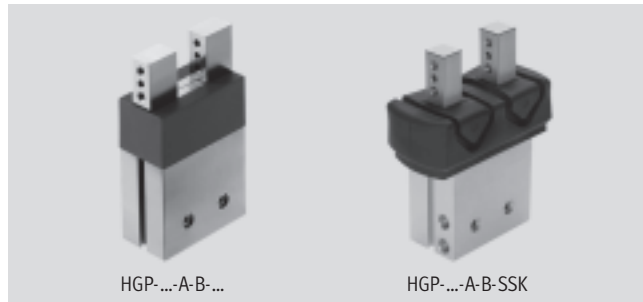

General technical data							
Size	6	10	16	20	25	35	
Design	Wedge-shaped		Lever mechanism				
Mode of operation	Double-acting						
Gripper function	Parallel						
Number of gripper jaws	2						
Max. applied load per external gripper finger ¹⁾	[N]	0.1	0.2	0.4	0.6	0.8	1.2
Stroke per gripper jaw	[mm]	2	3	5	6.5	7.5	12.5
Pneumatic connection		M3			M5	G1/8	
Repetition accuracy ²⁾	[mm]	≤ 0.04					
Max. interchangeability	[mm]	0.2					
Max. operating frequency	[Hz]	4					
Position sensing		For proximity sensing					
Type of mounting		With female thread and centring sleeve					
			Via through-holes and centring sleeve				

- 1) Valid for unthrottled operation
2) End position drift under constant conditions of use with 100 consecutive strokes in the direction of movement of the gripper jaws
- † - Note: This product conforms with the ISO 1179-1 standard and the ISO 228-1 standard.

Operating and environmental conditions						
Size	6	10	16	20	25	35
Min. operating pressure	HGP-...-A/-B [bar]	2				
	HGP-...-G... [bar]	5				
Max. operating pressure	[bar]	8				
Operating medium		Filtered compressed air, lubricated or unlubricated				
Ambient temperature	[°C]	+5 ... +60				
Corrosion resistance class CRC ¹⁾		2	1			

- 1) Corrosion resistance class 1 according to Festo standard 940 070
Components requiring low corrosion resistance. Transport and storage protection. Parts that do not have primarily decorative surface requirements, e.g. in internal areas that are not visible or behind covers.
Corrosion resistance class 2 according to Festo standard 940 070
Components requiring moderate corrosion resistance. Externally visible parts with primarily decorative surface requirements which are in direct contact with a normal industrial environment or media such as coolants or lubricating agents

Weights [g]						
Size	6	10	16	20	25	35
HGP-...-A	18	75	194	396	725	1 369
HGP-...-G1	-	76	197	402	737	1 387
HGP-...-G2	-	76	197	402	737	1 387
With protective dust cap						
HGP-...-SSK	-	-	197	-	737	-

Parallel grippers HGP

Technical data

Materials

Sectional view

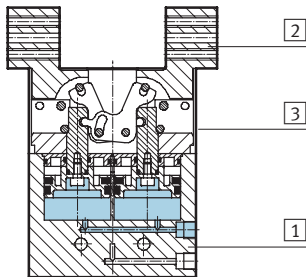

Parallel gripper	6	10	16	20	25	35
1 Body	Nickel-plated aluminium	Hard anodised aluminium				
2 Gripper jaw	Nickel-plated steel	High-alloy steel				
3 Cover cap	Polyamide					
- Protective dust cap SSK	-		Thermoplastic vulcanizate	-	Thermoplastic vulcanizate	-
- Note on materials	Copper, PTFE and silicone-free					

Gripping force [N] at 6 bar

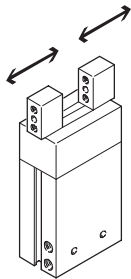

Size	6	10	16	20	25	35
Gripping force per gripper jaw						
Opening	10	22	70	120	185	375
Closing	10	17	80	115	170	350
Total gripping force						
Opening	20	44	140	240	370	750
Closing	20	34	160	230	340	700

Characteristic load values per gripper jaw

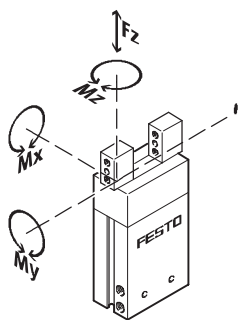

The indicated permissible forces and torques apply to a single gripper jaw. The indicated values include the lever arm, additional applied loads caused

by the workpiece or external gripper fingers, as well as forces which occur during movement.

The zero co-ordinate line (gripper jaw guide) must be taken into consideration for the calculation of torques.

Size	6	10	16	20	25	35	
Max. permissible force F_z	[N]	14	25	90	150	240	380
Max. permissible torque M_x	[Nm]	0.1	0.5	3.3	6	11	25
Max. permissible torque M_y	[Nm]	0.1	0.5	3.3	6	11	25
Max. permissible torque M_z	[Nm]	0.1	0.5	3.3	6	11	25

Parallel grippers HGP

Technical data



Mass moment of inertia [kgm²x10⁻⁴]

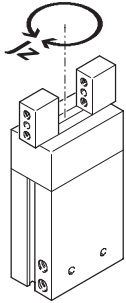

Mass moment of inertia [kgm²x10⁻⁴] for parallel grippers in relation to the central axis, without external gripper fingers, without load.

Size	6	10	16	20	25	35
HGP-...-A	0.01	0.08	0.47	1.49	3.83	12.70
HGP-...-G1	-	0.08	0.47	1.52	3.92	12.83
HGP-...-G2	-	0.08	0.47	1.49	3.84	12.73

Opening and closing times [ms] at 6 bar

without external gripper fingers

with external gripper fingers

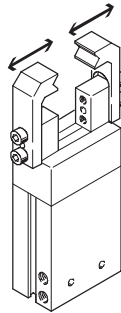
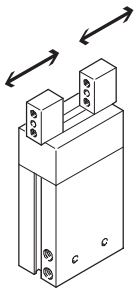

The indicated opening and closing times [ms] have been measured at room temperature and 6 bar operating pressure without external gripper fingers.

The grippers must be throttled for greater applied loads. Opening and closing times must then be adjusted accordingly.

Size		6	10	16	20	25	35
Without external gripper fingers							
HGP-...-A	Opening	5	22	44	32	47	77
	Closing	5	31	60	44	50	77
HGP-...-G1	Opening	-	17	39	30	39	71
	Closing	-	29	62	48	60	82
HGP-...-G2	Opening	-	33	66	39	62	90
	Closing	-	29	44	42	49	72
With external gripper fingers (as a function of applied load)							
HGP	0.06 N	5	-	-	-	-	-
	0.08 N	10	-	-	-	-	-
	0.10 N	20	-	-	-	-	-
	0.20 N	50	-	-	-	-	-
	0.50 N	-	100	-	-	-	-
	1.00 N	-	200	100	-	-	-
	1.25 N	-	-	-	100	-	-
	1.50 N	-	300	200	-	100	-
	1.75 N	-	-	-	200	-	-
	2.00 N	-	-	300	-	200	100
	2.50 N	-	-	-	300	-	-
	3.00 N	-	-	-	-	300	200
4.00 N	-	-	-	-	-	300	

Parallel grippers HGP

Technical data

Gripping force F_{Grip} per gripper jaw as a function of operating pressure and lever arm x

External and internal gripping (closing and opening)

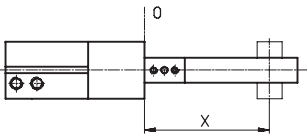

Gripping forces can be determined with the following diagrams for the various sizes in relation to operating

pressure and lever arm (distance from the zero co-ordinate line shown

opposite to the pressure point at which the fingers grip the workpiece).

HGP-06-A¹⁾

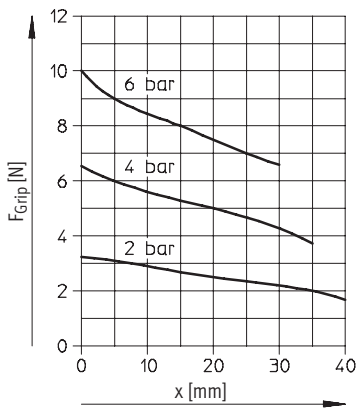

1) Due to the design, the opening and closing gripping forces for HGP-06-A are identical

HGP-10-A-B

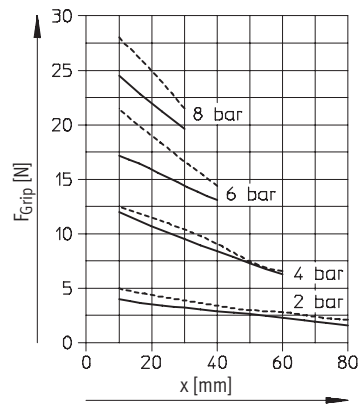

HGP-16-A-B

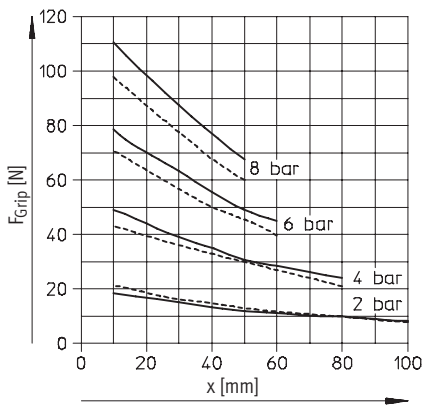

HGP-20-A-B

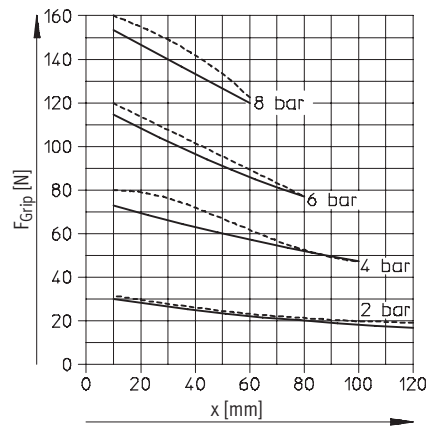

HGP-25-A-B

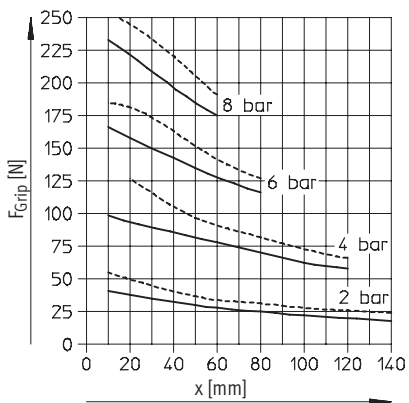

HGP-35-A-B

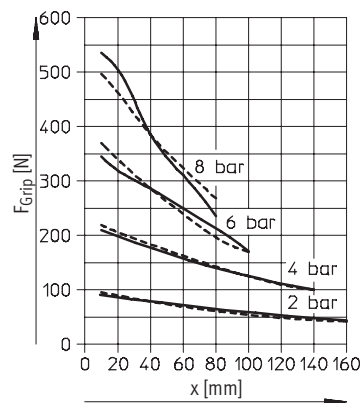

— Closing
 - - - Opening

Parallel grippers HGP

Technical data



Spring force F_{Spring} as a function of the gripper size and overall stroke length l

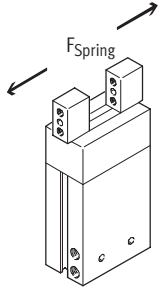

Gripper retention force, opening: the spring forces F_{Spring} of the parallel gripper HGP-...-G1 can be determined from the following graphs.

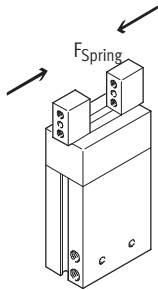
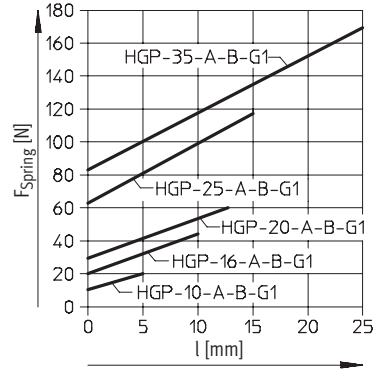

Gripper retention force, closing: the spring forces F_{Spring} of the parallel gripper HGP-...-G2 can be determined from the following graphs.

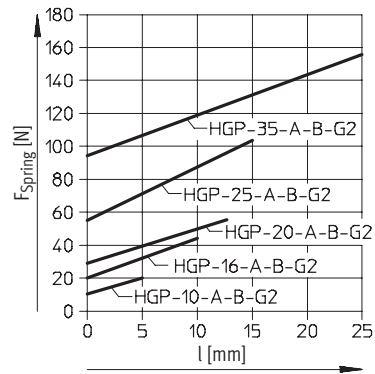

Determination of actual gripping forces for parallel grippers HGP-...-G1 and HGP-...-G2 depending upon the application

The parallel grippers with integrated spring can be used as:

- single-acting grippers
- grippers with supplementary gripping force and
- grippers with gripping force retention

In order to calculate available gripping forces F_{Gr} (per gripper jaw), the gripping force F_{Grip} and spring

force (F_{Spring}) must be combined accordingly.

Application

The resulting gripping force F_{Gr} , conditional on the application, depends on the gripping action (external/internal gripping) and the gripper design (with/without spring return). The spring force is supplemented in accordance with the design and gripping action.

Single-acting

- Gripping with spring force:
 $F_{Gr} = F_{Spring}$
- Gripping with pressure force:
 $F_{Gr} = F_{Grip} - F_{Spring}$

Supplementary gripping force

- Gripping with pressure and spring force:
 $F_{Gr} = F_{Grip} + F_{Spring}$

Gripping force retention

- Gripping with spring force:
 $F_{Gr} = F_{Spring}$

		Pressurised (in gripping action)	Unpressurised
HGP	Opening	$F_{Gr} = F_{Grip}$	$F_{Gr} = 0$
	Closing	$F_{Gr} = F_{Grip}$	$F_{Gr} = 0$
HGP-...-G1	Opening	$F_{Gr} = F_{Grip} + F_{Spring}$	$F_{Gr} = F_{Spring}$
	Closing	$F_{Gr} = F_{Grip} - F_{Spring}$	$F_{Gr} = 0$
HGP-...-G2	Opening	$F_{Gr} = F_{Grip} - F_{Spring}$	$F_{Gr} = 0$
	Closing	$F_{Gr} = F_{Grip} + F_{Spring}$	$F_{Gr} = F_{Spring}$

Parallel grippers HGP

Technical data

Gripping force F_{Grip} per gripper jaw at 6 bar as a function of lever arm x and eccentricity y

External and internal gripping (closing and opening)

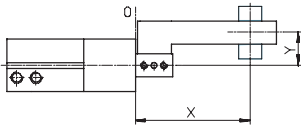

Gripping forces can be determined with the following diagrams for the various sizes at 6 bar in relation to

eccentric application of force (distance from the zero co-ordinate line shown opposite to the pressure point at

which the fingers grip the workpiece) and the maximum permissible off-centre point at which force is applied.

Calculation example

Given:

HGP-16-A-B

Lever arm $x = 20$ mm

Eccentricity $y = 22$ mm

To be found:

Gripping force at 6 bar

Procedure:

- Determine the intersection xy between lever arm x and eccentricity y in the graph for HGP-16-A-B
 - Draw an arc (with centre at origin) through intersection xy
 - Determine the intersection between the arc and the X axis
 - Read the gripping force
- Result:
Gripping force = approx. 66 N

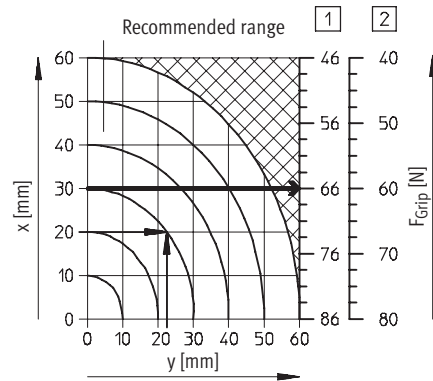

HGP-06-A

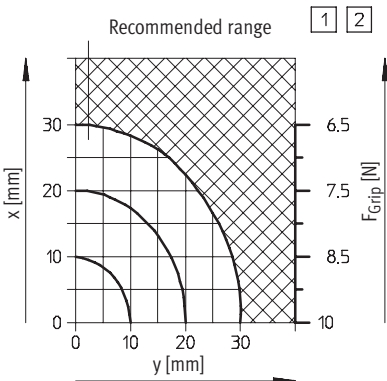

HGP-10-A-B

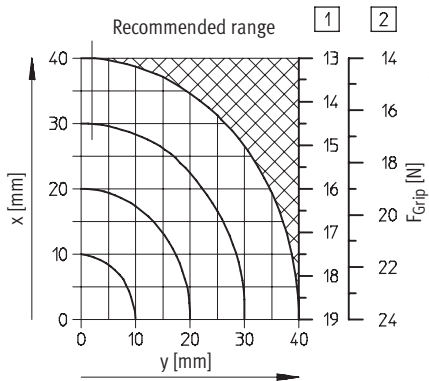

HGP-16-A-B

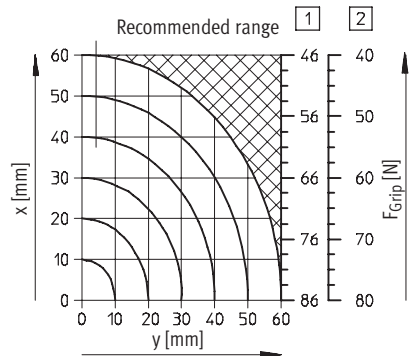

HGP-20-A

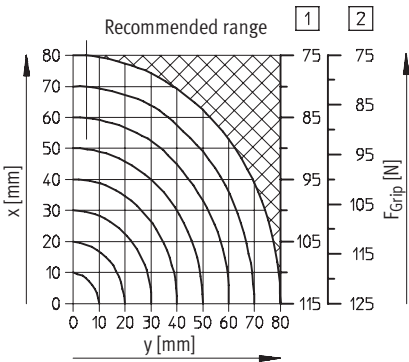

HGP-25-A-B

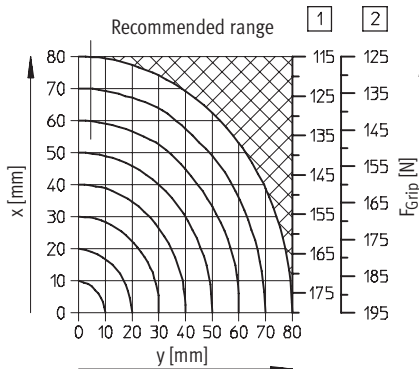

HGP-35-A-B

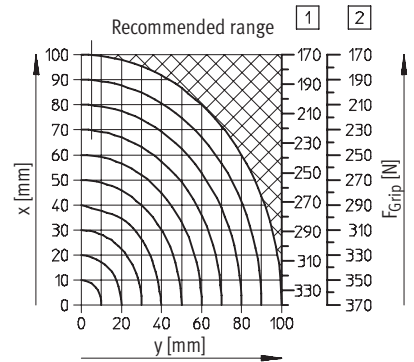

- 1 Closing
- 2 Opening

Parallel grippers HGP

Technical data



Dimensions

Download CAD data → www.festo.com/en/engineering

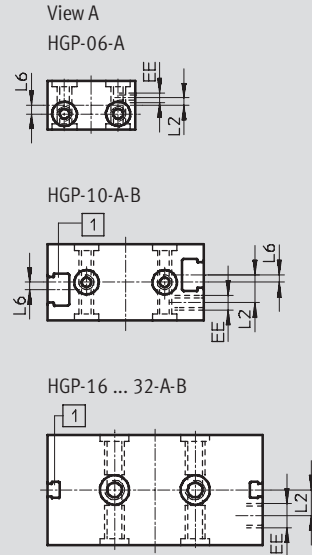
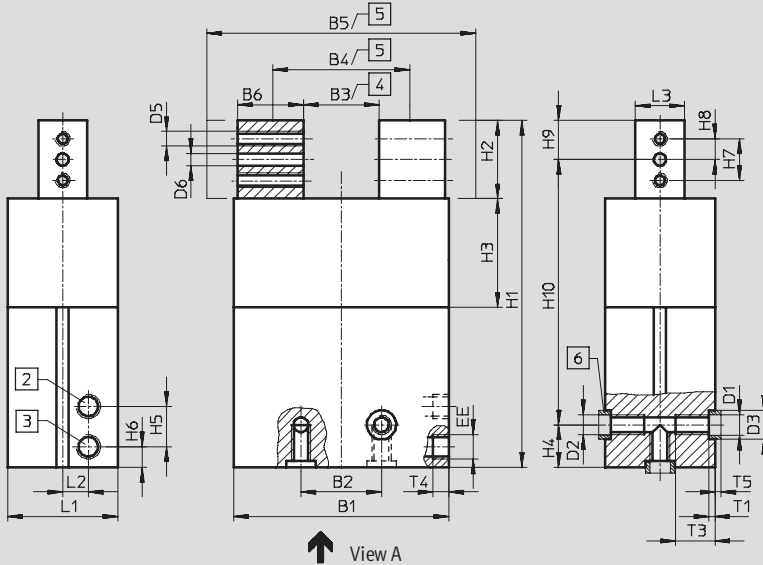

- 1 Sensor slot for proximity sensor SME/SMT-8 (not with HGP-06-A). Proximity sensors SME/SMT-10 can also be used in combination with the sensor strip HGP-SL... (can be glued into place).
- 2 Compressed air connection, opening
- 3 Compressed air connection, closing
- 4 Closed
- 5 Open
- 6 Centring sleeves ZBH (2 included in scope of delivery)

With protective dust cap HGP-...-SSK

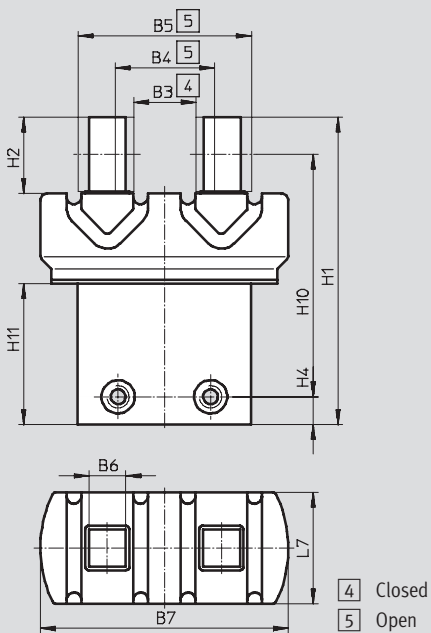

Handling units
Parallel grippers

7.5

Parallel grippers HGP

Technical data

FESTO

Type	B1	B2 ¹⁾	B3	B4	B5	B6	B7	D1	D2	D3	D5	D6	EE	H1	H2	H3	H4 ²⁾
		±0.1	±0.5	±0.5	±0.5	-0.03	±0.5	∅		∅		∅					±0.1
								H8/h7		H8							
HGP-06-A	18	11	6	10	21	5.5	-	3.2	M3	5	M2	1.5	M3	45.5	9.9	10.2	7.5
HGP-10-A-B	32	16	15.8	21.8	35.8	7	-	3.2	M3	5	M3	2	M3	66	15	16	7.5
HGP-16-A-B	47	25	17.8	27.8	53.8	13	-	5.3	M4	7	M4	3	M3	80	20	21.9	7.5
HGP-20-A-B	55.6	25	17.4	30.4	65.4	17.5	-	5.3	M4	7	M4	4	M5	101	24.9	26.1	7.5
HGP-25-A-B	68.2	29	21	36	80	22	-	6.4	M6	9	M5	4	G1/8	121	30	32.2	17.5
HGP-35-A-B	88	33	31	56	110	27	-	8.4	M8	12	M6	5	G1/8	142	31.9	44.8	17.5

With protective dust cap

HGP-16-A-B-SSK	47	25	16.4	26.4	46.4	10	67	5.3	M4	7	M4	3	M3	83	20.5	21.9	7.5
HGP-25-A-B-SSK	68.2	29	21	36	66	15	101	6.4	M6	9	M5	4	G1/8	126.8	31.5	32.2	17.5

Type	H5	H6	H7	H8	H9	H10	H11	L1	L2	L3	L6	L7	T1	T3	T4	T5
						±0.2				-0.03			+0.1	+1	+0.5	-0.3
HGP-06-A	7	4	5.8	2.9	5	33	-	10	1.5	5	1.8	-	1.2	-	3.5	1.2
HGP-10-A-B	7	4	8	4	7.5	51	-	15.5	4.2	7	1.5	-	1.2	6	3.5	1.2
HGP-16-A-B	7	4	11	5.5	10	62.5	-	22	5.7	10	-	-	1.6	7.5	3.5	1.4
HGP-20-A-B	10.5	11.5	14	7	12.5	81	-	30	9	12	-	-	1.6	8	6	1.4
HGP-25-A-B	16.5	8.3	16	8	15	88.5	-	37	10.5	15	-	-	2.1	15	6.5	1.9
HGP-35-A-B	16.5	8.5	17	8.5	16	108.5	-	45	10.5	20	-	-	2.6	16	6.5	2.4

With protective dust cap

HGP-16-A-B-SSK	7	4	11	5.5	10	65.5	38.1	22	5.7	10	-	30	1.6	7.5	3.5	1.4
HGP-25-A-B-SSK	16.5	8.3	16	8	15	94.3	58.8	37	10.5	15	-	47	2.1	15	6.5	1.9

1) Tolerance for centring hole: ±0.02

2) Tolerance for centring hole: -0.05

· † - Note: This product conforms with the ISO 1179-1 standard and the ISO 228-1 standard.

† - Note

Due to the distance H5 between the two air connections on types HGP-06/-10/-16 which measures

7 mm, only the following tube fittings can be used

- QSM-M3-3
- QSML-M3-3
- QSMLL-M3-3

- CN-M3-PK-3
- LCN-M3-PK-3
→ Volume 3

Parallel grippers HGP

Technical data

FESTO

Ordering data						
Size [mm]	Double-acting Without compression spring		Gripper retention force G1 Open		Gripper retention force G2 Closed	
	Part No.	Type	Part No.	Type	Part No.	Type
6	174 815	HGP-06-A	–		–	
10	197 542	HGP-10-A-B	197 543	HGP-10-A-B-G1	197 544	HGP-10-A-B-G2
16	197 545	HGP-16-A-B	197 546	HGP-16-A-B-G1	197 547	HGP-16-A-B-G2
20	525 889	HGP-20-A-B	525 890	HGP-20-A-B-G1	525 891	HGP-20-A-B-G2
25	197 548	HGP-25-A-B	197 549	HGP-25-A-B-G1	197 550	HGP-25-A-B-G2
35	197 551	HGP-35-A-B	197 552	HGP-35-A-B-G1	197 553	HGP-35-A-B-G2
With protective dust cap						
16	539 636	HGP-16-A-B-SSK	–		–	
25	539 635	HGP-25-A-B-SSK	–		–	

Ordering data – Wearing parts kits		
Size [mm]	Part No.	Type
6	378 516	HGP-06-A
10	397 376	HGP-10
16	397 377	HGP-16
20	397 378	HGP-20
25	397 397	HGP-25
32	397 380	HGP-35

Parallel grippers HGP

Accessories



Sensor rail HGP-SL



can be glued into place

Material:

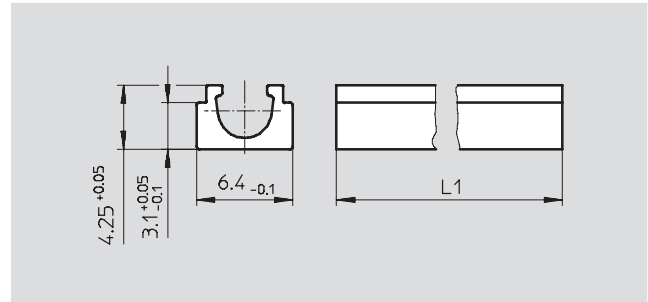
Wrought aluminium alloy

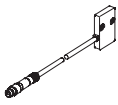

Dimensions and ordering data				
For size [mm]	L1	Weight [g]	Part No.	Type
10	35	1.4	535 582	HGP-SL-10-10
16	38	1.5	535 583	HGP-SL-10-16
20	50	2.0	535 584	HGP-SL-10-20
25	58	2.3	535 585	HGP-SL-10-25
35	65	2.6	535 586	HGP-SL-10-35

Ordering data					
Type	For size	Weight [g]	Part No.	Type	PU ¹⁾
Position sensor SMH-S1 Technical data → 2 / 107					
	6	20	175 710	SMH-S1-HGP06	1
Evaluation unit SMH-AE1 Technical data → 2 / 110					
	6	170	175 708	SMH-AE1-PS3-M12	1
			175 709	SMH-AE1-NS3-M12	
Centring sleeve ZBH Technical data → 1 / 10.1-3					
	6, 10	1	189 652	ZBH-5	10
	16, 20		186 717	ZBH-7	
	25		150 927	ZBH-9	
	35		189 653	ZBH-12	

1) Packaging unit quantity



Parallel grippers HGP



Accessories

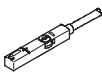

FESTO

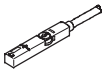
Handling units
Parallel grippers

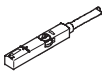
7.5

Ordering data – Proximity switches for T-slot, magneto-resistive					Technical data → www.festo.com/catalogue/sm	
	Type of mounting	Switch output	Electrical connection	Cable length [m]	Part No.	Type
N/O contact						
	Insertable in the slot from above, flush with cylinder profile	PNP	Cable, 3-wire	2,5	543 867	SMT-8M-PS-24V-K-2,5-OE
			Plug M8x1, 3-pin	0,3	543 866	SMT-8M-PS-24V-K-0,3-M8D
			Plug M12x1, 3-pin	0,3	543 869	SMT-8M-PS-24V-K-0,3-M12
		NPN	Cable, 3-wire	2,5	543 870	SMT-8M-NS-24V-K-2,5-OE
Plug M8x1, 3-pin	0,3		543 871	SMT-8M-NS-24V-K-0,3-M8D		
	Insertable in the slot lengthwise, flush with the cylinder profile	PNP	Cable, 3-wire	2,5	175 436	SMT-8-PS-K-LED-24-B
			Plug M8x1, 3-pin	0,3	175 484	SMT-8-PS-S-LED-24-B
N/C contact						
	Insertable in the slot from above, flush with cylinder profile	PNP	Cable, 3-wire	7,5	543 873	SMT-8M-PO-24V-K7,5-OE



Ordering data – Proximity switches for T-slot, magnetic reed					Technical data → www.festo.com/catalogue/sm	
	Type of mounting	Switch output	Electrical connection	Cable length [m]	Part No.	Type
N/O contact						
	Insertable in the slot from above, flush with cylinder profile	Contacting	Cable, 3-wire	2,5	543 862	SME-8M-DS-24V-K-2,5-OE
				5,0	543 863	SME-8M-DS-24V-K-5,0-OE
			Cable, 3-wire	2,5	543 872	SME-8M-ZS-24V-K-2,5-OE
			Plug M8x1, 3-pin	0,3	543 861	SME-8M-DS-24V-K-0,3-M8D
	Insertable in the slot lengthwise, flush with the cylinder profile	Contacting	Cable, 3-wire	2,5	150 855	SME-8-K-LED-24
			Plug M8x1, 3-pin	0,3	150 857	SME-8-S-LED-24
N/C contact						
	Insertable in the slot lengthwise, flush with the cylinder profile	Contacting	Cable, 3-wire	7,5	160 251	SME-8-O-K-LED-24



Ordering data – Connecting cable				Technical data → www.festo.com/catalogue/nebu	
	Electrical connection, left	Electrical connection, right	Cable length [m]	Part No.	Type
	Straight socket, M8x1, 3-pin	Cable, open end, 3-wire	2,5	541 333	NEBU-M8G3-K-2.5-LE3
			5	541 334	NEBU-M8G3-K-5-LE3
	Straight socket, M12x1, 5-pin	Cable, open end, 3-wire	2,5	541 363	NEBU-M12G5-K-2.5-LE3
			5	541 364	NEBU-M12G5-K-5-LE3
	Angled socket, M8x1, 3-pin	Cable, open end, 3-wire	2,5	541 338	NEBU-M8W3-K-2.5-LE3
			5	541 341	NEBU-M8W3-K-5-LE3
	Angled socket, M12x1, 5-pin	Cable, open end, 3-wire	2,5	541 367	NEBU-M12W5-K-2.5-LE3
			5	541 370	NEBU-M12W5-K-5-LE3



Parallel grippers HGP

Accessories

FESTO

Ordering data – Proximity switches for C-slot, magneto-resistive					Technical data → www.festo.com/catalogue/sm	
	Type of mounting	Switch output	Electrical connection, connection direction	Cable length [m]	Part No.	Type
N/O contact						
	Insertable in the slot from above, flush with cylinder profile	PNP	Cable, 3-wire, in-line	2,5	525 915	SMT-10F-PS-24V-K2,5L-OE
			Plug M8x1, 3-pin, in-line	0,3	525 916	SMT-10F-PS-24V-K0,3L-M8D
			Plug M8x1, 3-pin, lateral	0,3	526 675	SMT-10F-PS-24V-K0,3Q-M8D
	Insertable in the slot lengthwise	PNP	Plug M8x1, 3-pin, in-line	0,3	173 220	SMT-10-PS-SL-LED-24
			Cable, 3-wire, in-line	2,5	173 218	SMT-10-PS-KL-LED-24

Ordering data – Proximity switches for C-slot, magnetic reed					Technical data → www.festo.com/catalogue/sm	
	Type of mounting	Switch output	Electrical connection, connection direction	Cable length [m]	Part No.	Type
N/O contact						
	Insertable in the slot from above, flush with cylinder profile	Contacting	Plug M8x1, 3-pin, in-line	0,3	525 914	SME-10F-DS-24V-K0,3L-M8D
			Cable, 3-wire, in-line	2,5	525 913	SME-10F-DS-24V-K2,5L-OE
			Cable, 2-wire, in-line	2,5	526 672	SME-10F-ZS-24V-K2,5L-OE
	Insertable in the slot lengthwise	Contacting	Plug M8x1, 3-pin, in-line	0,3	173 212	SME-10-SL-LED-24
			Cable, 3-wire, in-line	2,5	173 210	SME-10-KL-LED-24

Ordering data – Connecting cable				Technical data → www.festo.com/catalogue/nebu	
	Electrical connection, left	Electrical connection, right	Cable length [m]	Part No.	Type
	Straight socket, M8x1, 3-pin	Cable, open end, 3-wire	2,5	541 333	NEBU-M8G3-K-2.5-LE3
			5	541 334	NEBU-M8G3-K-5-LE3
	Angled socket, M8x1, 3-pin	Cable, open end, 3-wire	2,5	541 338	NEBU-M8W3-K-2.5-LE3
			5	541 341	NEBU-M8W3-K-5-LE3

Handling units
Parallel grippers

7.5

