



- Holding, clamping and cushioning
- Up to 2,000 mm stroke
- Extensive range of accessories

# Clamping-unit cylinders, standard port pattern

Key features

FESTO

## At a glance

Clamping units are generally used for the friction locking of longitudinally variable rods at any position. The attachment of a clamping unit to a pneumatic cylinder allows the piston rod to be clamped. This clamping unit is designed to lock the piston rod securely so that the application of

external force on the piston rod does not produce any relative motion. The locking of the piston rod can take place at any position in the stroke, in the end positions as well as the intermediate positions.

- Clamping force is released when compressed air is fed to the clamping unit
- Static holding force of up to 8,000 N
- The cylinders comply with ISO 15552, (DIN ISO 6431), except where length is concerned.

## Selection aid

Clamping-unit cylinder DNCKE

1 / 5.11-6



- **For use as holding device (static application):**
  - Holding and clamping in the event of a power failure
  - Protection against pressure failure and pressure drop
  - Securing of the piston rod during intermediate stops for process operations
- Wide selection of mounting options

Clamping-unit cylinder DNCKE-S, for safety-related applications

1 / 5.11-9



- **For use as holding device (static application):**
  - Holding and clamping in the event of a power failure
  - Protection against pressure failure and pressure drop
  - Securing of the piston rod during intermediate stops for process operations
- **For use as a braking device (dynamic application):**
  - Braking or stopping of movements
  - Suspension of movement upon entering a danger area
- Holding force of the clamping unit is greater than the max. permissible feed force of the cylinder
- For use in category 1 control systems to DIN EN 954-1 ("reliable component"). For use in higher categories, additional control measures are required
- Certified for use in safety-relevant control systems by the BG-Institute for Occupational Safety and Health (Berufsgenossenschaftlichen Institut für Arbeitssicherheit – BGI) in Germany
- When used as a braking device, the overtravel must be checked regularly
- CE marking as per EC machinery directive
- Products intended for use in safety-related applications must be selected, sized and arranged in accordance with the risk assessment (EN1050) as well as any other valid standards and regulations

# Clamping-unit cylinders, standard port pattern

Type codes

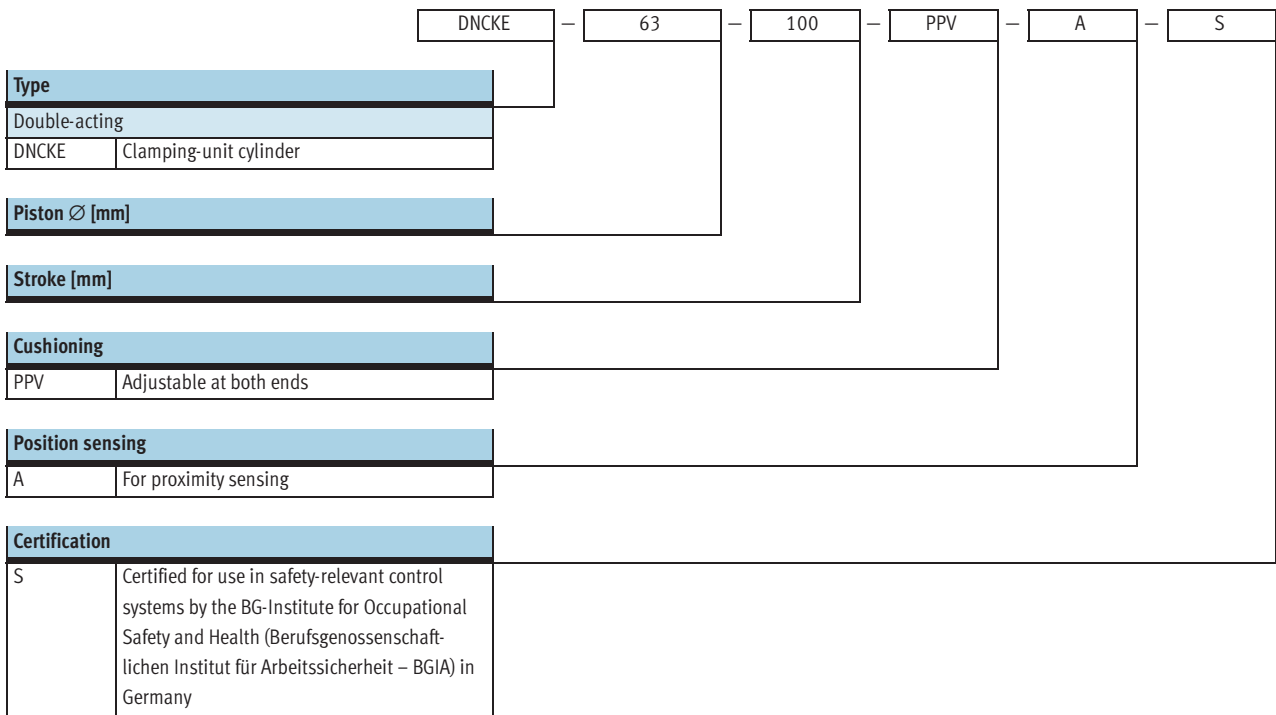

# Clamping-unit cylinders, standard port pattern

Peripherals overview

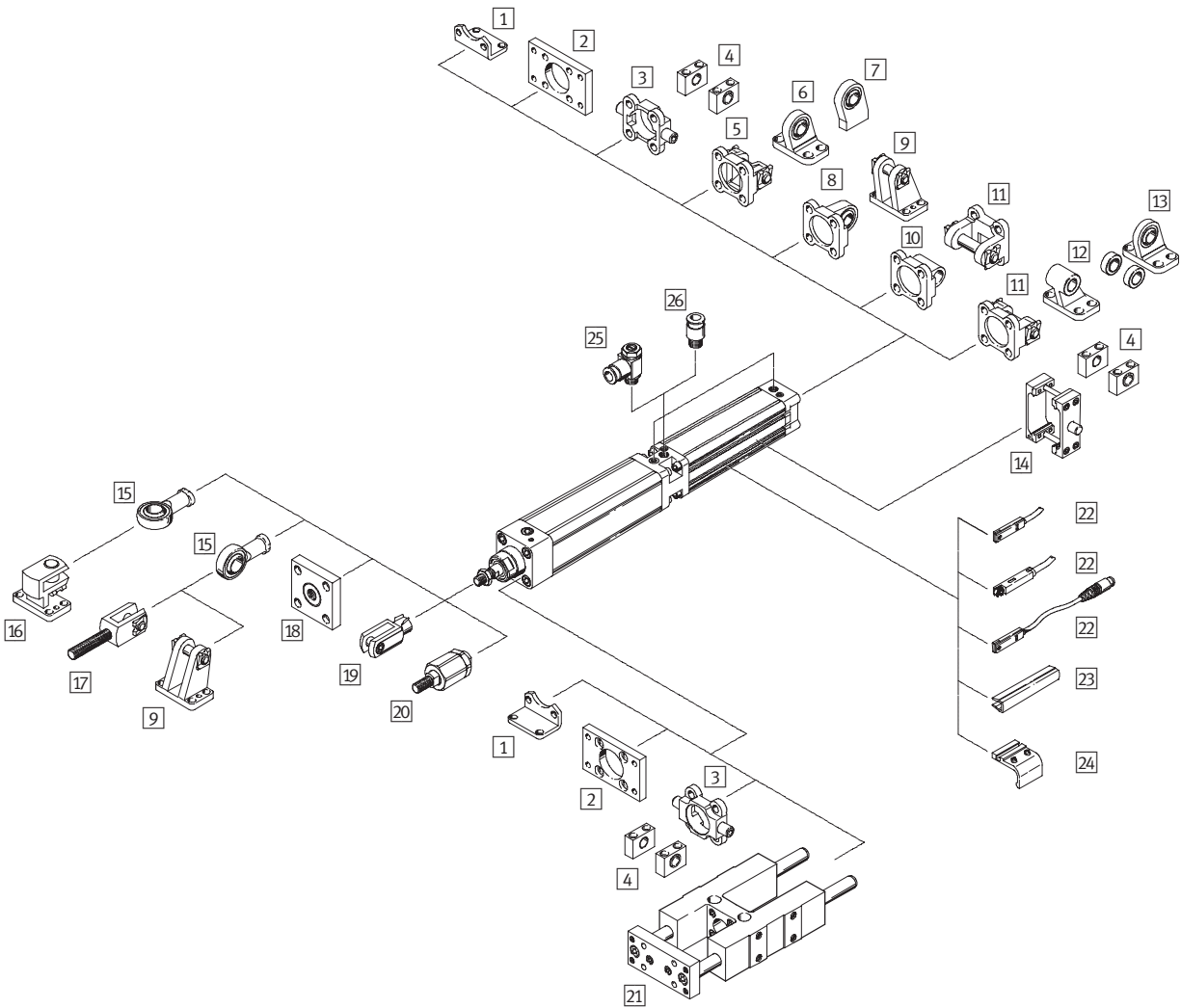

# Clamping-unit cylinders, standard port pattern

Peripherals overview

FESTO

Mounting attachments and accessories					
	Brief description	DNCKE	DNCKE-S	→ Page	
1	Foot mounting HNC	For bearing or end cap	■	■	1 / 5.11-14
2	Flange mounting FNC	For bearing or end cap	■	■	1 / 5.11-14
3	Trunnion flange ZNCF	For bearing or end cap	■	–	1 / 5.11-15
4	Trunnion support LNZG	For trunnion flange ZNCF	■	–	1 / 5.11-16
5	Swivel flange SNC	For end cap	■	–	1 / 5.11-16
6	Clevis foot LSNG	With spherical bearing	■	–	1 / 5.11-18
7	Clevis foot LSNSG	Weld-on, with spherical bearing	■	–	1 / 5.11-18
8	Swivel flange SNCS	With spherical bearing for end cap	■	–	1 / 5.11-17
9	Clevis foot LBG	For swivel flange SNCS	■	–	1 / 5.11-18
10	Swivel flange SNCL	For end cap	■	–	1 / 5.11-18
11	Swivel flange SNCB	For end cap	■	–	1 / 5.11-17
12	Clevis foot LNG	For swivel flange SNCB	■	–	1 / 5.11-18
13	Clevis foot LSN	With spherical bearing	■	–	1 / 5.11-18
14	Trunnion mounting kit ZNCM	For mounting anywhere along the cylinder profile barrel	■	–	1 / 5.11-15
15	Rod eye SGS	With spherical bearing	■	–	1 / 5.11-19
16	Right-angle clevis foot LQG	For rod eye SGS	■	–	1 / 5.11-18
17	Rod clevis SGA	With male thread	■	–	1 / 5.11-19
18	Coupling piece KSG	For compensating radial deviations	■	–	1 / 5.11-19
19	Rod clevis SG	Permits a swivelling movement of the cylinder in one plane	■	–	1 / 5.11-19
20	Self-aligning rod coupler FK	For compensating radial and angular deviations	■	■	1 / 5.11-19
21	Guide unit FENG	For protecting standard cylinders from torsion at high torque loads	■	■	1 / 5.11-19
22	Proximity sensor SME/SMT	Can be integrated in the cylinder profile barrel	■	■	1 / 5.11-20
23	Slot cover ABP-5-S	To protect the sensor cable and keep dirt out of the sensor slots	■	■	1 / 5.11-21
24	Sensor mounting kit SMB-8-FENG	For proximity sensor SMT-8 when attaching to cylinders in combination with guide unit FENG	■	■	1 / 5.11-20
25	One-way flow control valve GRLA	For speed regulation	■	■	1 / 5.11-21
26	Push-in fitting QS	For connecting compressed air tubing with standard external diameters	■	■	Volume 3



# Clamping unit cylinders DNCKE, standard port pattern

FESTO

Technical data

Function



-  Diameter  
40, 63, 100 mm
-  Stroke length  
10 ... 2,000 mm



-  Note

Additional measures are required for use in safety-related control systems; in Europe, for example, the standards listed under the EC Machinery Directive must be observed. Without

additional measures in accordance with statutory minimum requirements, the product is not suitable for use in safety-related sections of control systems.

General technical data				
Piston Ø		40	63	100
Pneumatic connection	Cylinder	G <sup>1</sup> / <sub>4</sub>	G <sup>3</sup> / <sub>8</sub>	G <sup>1</sup> / <sub>2</sub>
	Clamping unit	G <sup>1</sup> / <sub>8</sub>	G <sup>1</sup> / <sub>4</sub>	G <sup>3</sup> / <sub>8</sub>
Piston rod thread		M12x1.25	M16x1.5	M20x1.5
Design	Piston			
	Piston rod			
	Cylinder barrel			
Cushioning		Adjustable at both ends		
Cushioning length	[mm]	20	22	32
Position sensing		For proximity sensing		
Type of mounting		Via female thread		
		With accessories		
Clamping type with effective direction		At both ends		
		Clamping via spring force, air to release		
Assembly position		Any		

-  Note: This product conforms with the ISO 1179-1 standard and the ISO 228-1 standard.

Operating and environmental conditions				
Piston Ø		40	63	100
Operating medium		Filtered compressed air, lubricated or unlubricated		
Operating pressure	[bar]	0.6 ... 10		
Min. release pressure	[bar]	3.8		
Ambient temperature <sup>1)</sup>	[°C]	-20 ... +80		

1) Note operating range of proximity sensors

Weights [g]				
Piston Ø		40	63	100
Basic weight with 0 mm stroke		2,340	5,485	18,160
Additional weight per 10 mm stroke		45	73	110
Moving load with 0 mm stroke		500	935	2,150
Additional load per 10 mm stroke		16	25	40

# Clamping unit cylinders DNCKE, standard port pattern

Technical data



Forces [N]			
Piston Ø	40	63	100
Theoretical force at 6 bar, advancing	754	1,870	4,712
Theoretical force at 6 bar, retracting	633	1,682	4,418
Static holding force	1,300	3,200	8,000

- Note

The specified holding force refers to a static load. If this value is exceeded, slippage may occur. Dynamic forces occurring during operation must not exceed the static holding force if slippage is to be avoided. The clamping unit is backlash-free in the clamped condition if varying loads are applied to the piston rod.

Activation:  
The clamping unit may only be released when equilibrium of forces is present on the piston rod. Otherwise there is a risk of accidents due to the sudden movement of the piston rod. Blocking off the air supply at both ends (e.g. with a 5/3-way valve) does not provide any safety.

Impact energy [J]			
Piston Ø	40	63	100
Max. impact energy at end positions	0.7	1.3	3

Permissible impact velocity:

$$v_{perm.} = \sqrt{\frac{2 \times E_{perm.}}{m_{dead} + m_{load}}}$$

Maximum permissible load:

$$m_{load} = \frac{2 \times E_{perm.}}{v^2} - m_{dead}$$

- Note

This data represents the maximum values that can be achieved. Values fluctuate in practice relative to the size of the working load. Allowance must also be made for the limits of the cushioning capacity of the drive and the permissible impact energy.

## Materials

Sectional view

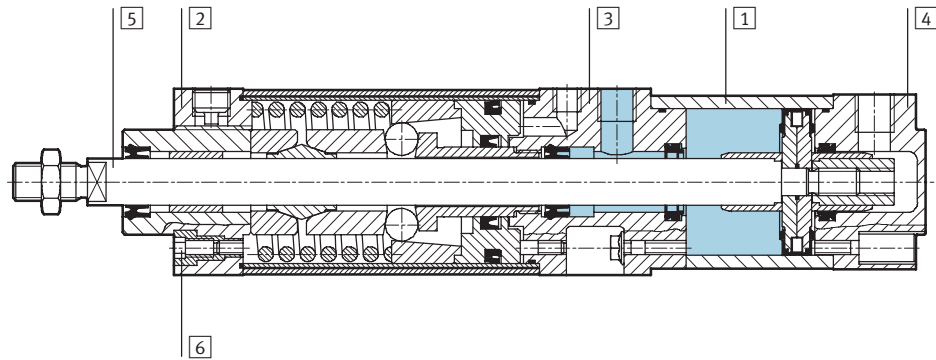

Cylinder		
1	Housing	Wrought aluminium alloy
2	Bearing cap	Wrought aluminium alloy
3	Connector cap	Wrought aluminium alloy
4	End cap	Die-cast aluminium
5	Piston rod	Tempered steel
6	Flange screws	Tempered steel
-	Seals	Polyurethane, nitrile rubber

# Clamping unit cylinders DNCKE, standard port pattern

Technical data

FESTO

**Dimensions** Download CAD data → [www.festo.com/en/engineering](http://www.festo.com/en/engineering)

**1** Socket head screw with female thread for mounting components  
**2** Regulating screw for adjustable end-position cushioning  
**3** Sensor slot for proximity sensor  
**4** Connection to release clamping function  
**5** Locking screw

+ = plus stroke length

∅	AM	B ∅ d11	BG	BG1	E	EE	E1	G	G2	G3	J1
[mm]											
40	24	35	16	15	54	G <sup>1</sup> / <sub>4</sub>	G <sup>1</sup> / <sub>8</sub>	28.8	22	49.6	2
63	32	45	17	17	80	G <sup>3</sup> / <sub>8</sub>	G <sup>1</sup> / <sub>4</sub>	34.3	29.5	47.9	7
100	42	55	17	17	126	G <sup>1</sup> / <sub>2</sub>	G <sup>3</sup> / <sub>8</sub>	38	32.5	46.7	15

∅	J2	J3	J4	KK	L1	L2	L7	MM ∅	PL	PL1	PL2
[mm]											
40	8	6	0	M12x1.25	17.9	114.5	3.6	16	14	21.3	9
63	12.4	10	7	M16x1.5	22.1	121.5	6.6	20	17	14.6	11.8
100	12	10	10	M20x1.5	29.2	131.5	8	25	18.8	16.4	14.4

∅	RT	TG	VA	WH	ZJ	∅C1	∅C2	∅C3	∅C4	∅C5	∅C6
[mm]											
40	M6	38	4	30	277	13	19	6	6	30	8
63	M8	56.5	4	37	315	17	24	8	8	36	10
100	M10	89	4	51	408	22	30	6	10	41	13

• Note: This product conforms with the ISO 1179-1 standard and the ISO 228-1 standard.

Ordering data		Part No.	Type
Piston ∅ [mm]	Stroke [mm]		
40	10 ... 2,000	526 482	DNCKE-40-...-PPV-A
63	10 ... 2,000	526 483	DNCKE-63-...-PPV-A
100	10 ... 2,000	526 484	DNCKE-100-...-PPV-A





# Clamping unit cylinders DNCKE-S, standard port pattern

FESTO

Technical data

Function



-  - Diameter  
40, 63, 100 mm
-  - Stroke length  
10 ... 2,000 mm



General technical data				
Piston Ø		40	63	100
Pneumatic connection	Cylinder	G $\frac{1}{4}$	G $\frac{3}{8}$	G $\frac{1}{2}$
	Clamping unit	G $\frac{1}{8}$	G $\frac{1}{4}$	G $\frac{3}{8}$
Piston rod thread		M12x1.25	M16x1.5	M20x1.5
Design		Piston		
		Piston rod		
		Cylinder barrel		
Cushioning		Adjustable at both ends		
Cushioning length	[mm]	20	22	32
Position sensing		For proximity sensing		
Type of mounting		Via female thread		
		With accessories		
Clamping type with effective direction		At both ends		
		Clamping via spring force, air to release		
Assembly position		Any		
Safety category		Cat 1 to DIN EN 954-1		
Certification		BGIA (Berufsgenossenschaftliches Institut für Arbeitssicherheit – BG-Institute for Occupational Safety and Health)		
CE marking (see declaration of conformity)		As per EC machinery directive		

-  - Note: This product conforms with the ISO 1179-1 standard and the ISO 228-1 standard.

Operating and environmental conditions				
Piston Ø		40	63	100
Operating medium		Filtered compressed air, lubricated or unlubricated		
Operating pressure	[bar]	0.6 ... 8		
Min. release pressure	[bar]	3.8		
Max. permissible test pressure	[bar]	10		
Ambient temperature <sup>1)</sup>	[°C]	-10 ... +60		

1) Note operating range of proximity sensors

Weights [g]				
Piston Ø		40	63	100
Basic weight with 0 mm stroke		2,340	5,485	18,160
Additional weight per 10 mm stroke		45	73	110
Moving load with 0 mm stroke		500	935	2,150
Additional load per 10 mm stroke		16	25	40

# Clamping unit cylinders DNCKE-S, standard port pattern



Technical data

Forces [N]			
Piston $\varnothing$	40	63	100
Theoretical force at 6 bar, advancing	754	1,870	4,712
Theoretical force at 6 bar, retracting	633	1,682	4,418
Static holding force	1,300	3,200	8,000

 - Note

The specified holding force refers to a static load. If this value is exceeded, slippage may occur. Dynamic forces occurring during operation must not exceed the static holding force if slippage is to be avoided. The clamping unit is backlash-free in the clamped condition if varying loads are applied to the piston rod.

Activation:  
The clamping unit may only be released when equilibrium of forces is present on the piston rod. Otherwise there is a risk of accidents due to the sudden movement of the piston rod. Blocking off the air supply at both ends (e.g. with a 5/3-way valve) does not provide any safety.

## Max. axial force F as a function of the operating pressure p

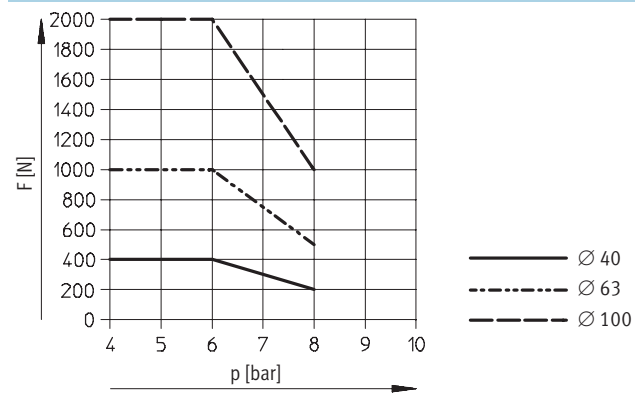

Forces [N]			
Piston $\varnothing$	40	63	100
Axial force at			
4 ... 6 bar	400	1,000	2,000
7 bar	300	700	1,500
8 bar	200	500	1,000

# Clamping unit cylinders DNCKE-S, standard port pattern

Technical data

 Note

The overtravel is the distance that the piston rod covers between exhausting of the clamping unit and coming to a standstill. It must be determined by the customer when setting up the machine and be compared with the calculated overtravel

(see DIN EN 999). For use in higher categories than category 1 to DIN 954-1, the overtravel must also be reached in the event of an error. It is dependent on the environmental conditions and stress, e.g.:

- Operating pressure
- Nominal size of switching valve
- Line length
- Diameter of connecting cable to clamping unit
- Load and speed

The overtravel can be reduced by attaching a quick exhaust valve to the supply port of the clamping unit.

## Theoretical overtravel $s$ as a function of the piston speed $v$ in a vertical assembly position

Ø 40

Ø 63

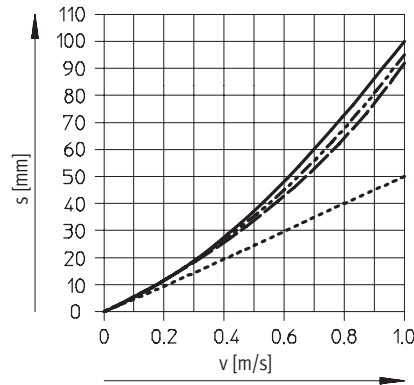
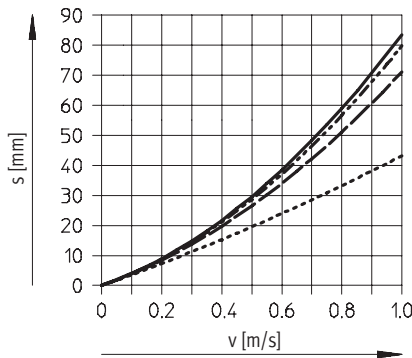

Ø 100

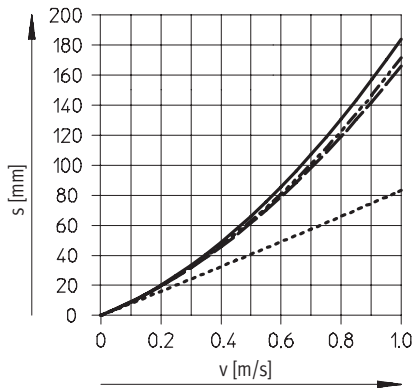

# Clamping unit cylinders DNCKE-S, standard port pattern

Technical data



Impact energy [J]			
Piston Ø	40	63	100
Max. impact energy at end positions	0.7	1.3	3

Permissible impact velocity: 
$$v_{perm.} = \sqrt{\frac{2 \times E_{perm.}}{m_{dead} + m_{load}}}$$

Maximum permissible load: 
$$m_{load} = \frac{2 \times E_{perm.}}{v^2} - m_{dead}$$

- - Note

This data represents the maximum values that can be achieved. Values fluctuate in practice relative to the size of the working load. Allowance

must also be made for the limits of the cushioning capacity of the drive and the permissible impact energy.

## Materials

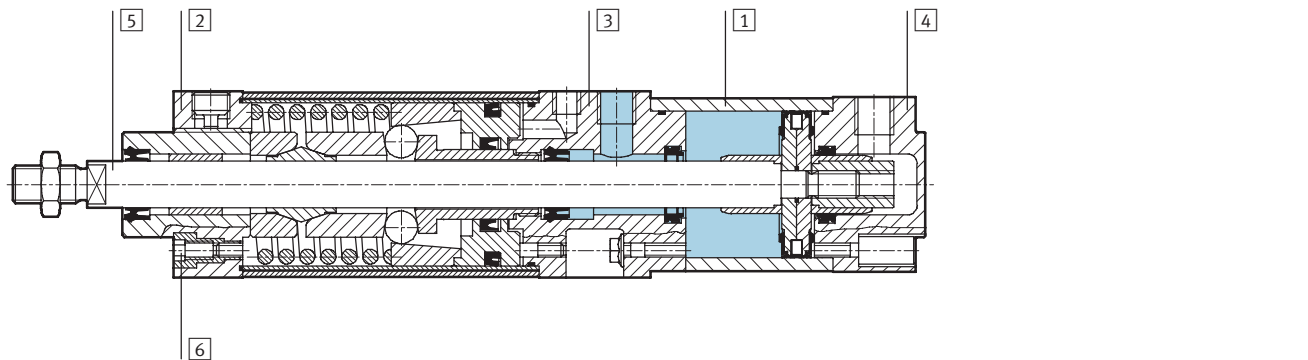

Cylinder		
1	Body	Wrought aluminium alloy
2	Bearing cap	Wrought aluminium alloy
3	Connector cap	Wrought aluminium alloy
4	End cap	Die-cast aluminium
5	Piston rod	Tempered steel
6	Flange screws	Tempered steel
-	Seals	Polyurethane, nitrile rubber

## Recommendation for mounting

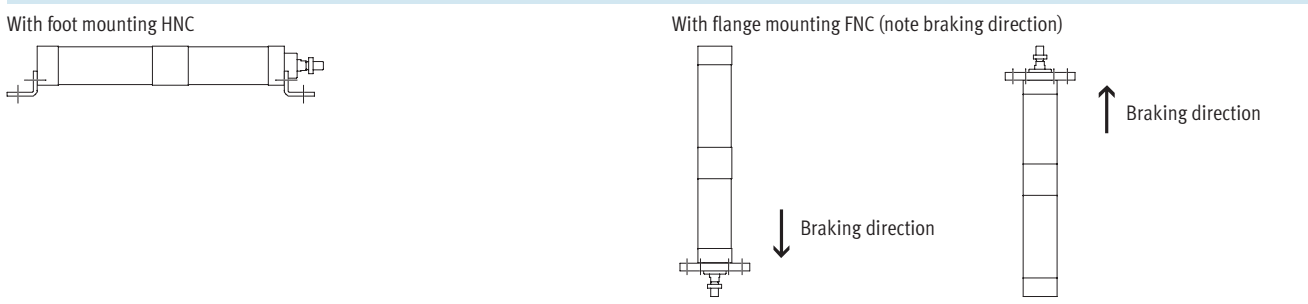

Special-function drives  
Clamping cylinders

# Clamping unit cylinders DNCKE-S, standard port pattern

Technical data



Download CAD data → [www.festo.com/en/engineering](http://www.festo.com/en/engineering)

**1** Socket head screw with female thread for mounting components

**2** Regulating screw for adjustable end-position cushioning

**3** Sensor slot for proximity sensor

**4** Connection to release clamping function

**5** Locking screw

+ = plus stroke length

∅	AM	B ∅ d11	BG	BG1	E	EE	E1	G	G2	G3	J1
[mm]											
40	24	35	16	15	54	G <sup>1</sup> / <sub>4</sub>	G <sup>1</sup> / <sub>8</sub>	28.8	22	49.6	2
63	32	45	17	17	80	G <sup>3</sup> / <sub>8</sub>	G <sup>1</sup> / <sub>4</sub>	34.3	29.5	47.9	7
100	42	55	17	17	126	G <sup>1</sup> / <sub>2</sub>	G <sup>3</sup> / <sub>8</sub>	38	32.5	46.7	15

∅	J2	J3	J4	KK	L1	L2	L7	MM ∅	PL	PL1	PL2
[mm]											
40	8	6	0	M12x1.25	17.9	114.5	3.6	16	14	21.3	9
63	12.4	10	7	M16x1.5	22.1	121.5	6.6	20	17	14.6	11.8
100	12	10	10	M20x1.5	29.2	131.5	8	25	18.8	16.4	14.4

∅	RT	TG	VA	WH	ZJ	∅C1	∅C2	∅C3	∅C4	∅C5	∅C6
[mm]											
40	M6	38	4	30	277	13	19	6	6	30	8
63	M8	56.5	4	37	315	17	24	8	8	36	10
100	M10	89	4	51	408	22	30	6	10	41	13

• Note: This product conforms with the ISO 1179-1 standard and the ISO 228-1 standard.

Ordering data		Part No.	Type
Piston ∅ [mm]	Stroke [mm]		
40	10 ... 2,000	538 239	DNCKE-40-...-PPV-A-S
63	10 ... 2,000	538 240	DNCKE-63-...-PPV-A-S
100	10 ... 2,000	538 241	DNCKE-100-...-PPV-A-S

# Clamping-unit cylinders, standard port pattern

Accessories



## Foot mounting HNC

Material:  
Galvanised steel  
Free of copper, PTFE and silicone

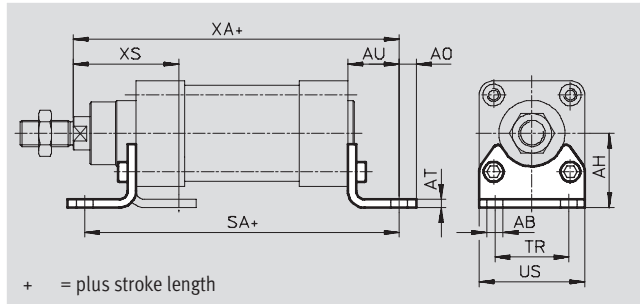

Dimensions and ordering data														
For $\varnothing$	AB	AH	AO	AT	AU	SA	TR	US	XA	XS	CRC <sup>1)</sup>	Weight	Part No.	Type
[mm]	$\varnothing$											[g]		
40	10	36	9	4	28	303	36	54	305	53	2	180	174 370	HNC-40
63	10	50	12.5	5	32	342	50	75	347	63	2	405	174 372	HNC-63
100	14.5	71	17.5	6	41	439	75	110	449	86	2	1,000	174 374	HNC-100

1) Corrosion resistance class 2 according to Festo standard 940 070  
Components requiring moderate corrosion resistance. Externally visible parts with primarily decorative surface requirements which are in direct contact with a normal industrial environment or media such as coolants or lubricating agents.

## Flange mounting FNC

Material:  
Galvanised steel  
Free of copper, PTFE and silicone

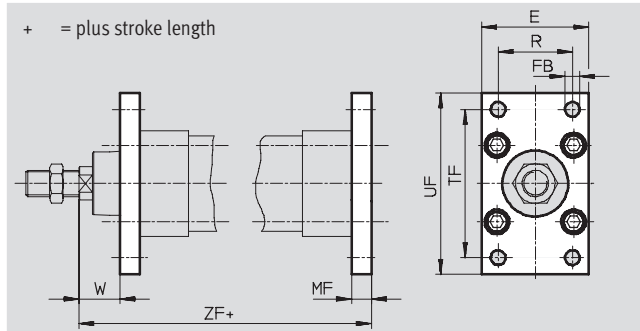

Dimensions and ordering data													
For $\varnothing$	E	FB	MF	R	TF	UF	W	ZF	CRC <sup>1)</sup>	Weight	Part No.	Type	
[mm]		$\varnothing$ H13								[g]			
40	54	9	10	36	72	90	20	287	2	280	174 377	FNC-40	
63	75	9	12	50	100	120	25	327	2	690	174 379	FNC-63	
100	110	14	16	75	150	175	35	424	2	2,400	174 381	FNC-100	

1) Corrosion resistance class 2 according to Festo standard 940 070  
Components requiring moderate corrosion resistance. Externally visible parts with primarily decorative surface requirements which are in direct contact with a normal industrial environment or media such as coolants or lubricating agents.

# Clamping-unit cylinders, standard port pattern

Accessories

## Trunnion flange ZNCF

Material:  
Special steel casting  
Free of copper, PTFE and silicone

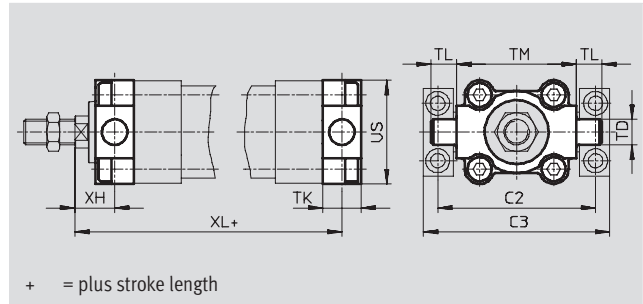
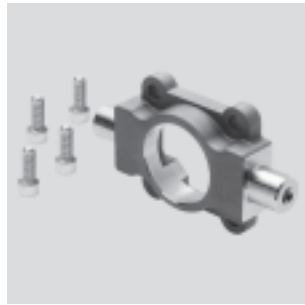

+ = plus stroke length

Dimensions and ordering data													
For Ø	C2	C3	TD	TK	TL	TM	US	XH	XL	CRC <sup>1)</sup>	Weight	Part No.	Type
[mm]			Ø e9								[g]		
40	87	105	16	20	16	63	54	20	287	2	240	174 412	ZNCF-40
63	116	136	20	24	20	90	75	25	327	2	600	174 414	ZNCF-63
100	164	189	25	38	25	132	110	32	427	2	2,030	174 416	ZNCF-100

1) Corrosion resistance class 2 according to Festo standard 940 070  
Components requiring moderate corrosion resistance. Externally visible parts with primarily decorative surface requirements which are in direct contact with a normal industrial environment or media such as coolants or lubricating agents.

## Trunnion mounting kit ZNCM

The mounting kit can be attached at any position along the profile barrel of a cylinder.

Material:  
Tempered steel

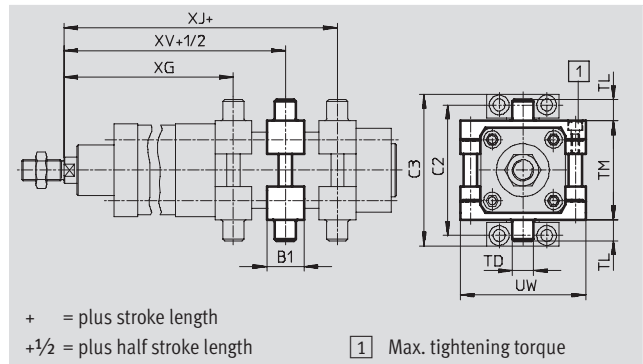

+ = plus stroke length

+1/2 = plus half stroke length

1 Max. tightening torque

Dimensions and ordering data							
For Ø	B1	C2	C3	TD	TL	TM	UW
[mm]				Ø e9			
40	32	87	105	16	16	63	75
63	41	116	136	20	20	90	105
100	48	164	189	25	25	132	145

For Ø	XG	XJ	XV	Max. tightening torque	CRC <sup>1)</sup>	Weight	Part No.	Type
[mm]				[Nm]		[g]		
40	228.1	232.2	230.2	8+1	2	385	163 526	ZNCM-40
63	261.9	260.2	261	18+2	2	890	163 528	ZNCM-63
100	347.2	346	346.6	28+2	2	2,045	163 530	ZNCM-100

1) Corrosion resistance class 2 according to Festo standard 940 070  
Components requiring moderate corrosion resistance. Externally visible parts with primarily decorative surface requirements which are in direct contact with a normal industrial environment or media such as coolants or lubricating agents.

# Clamping-unit cylinders, standard port pattern

Accessories



## Trunnion support LNZG

Material:

Trunnion support:

Anodised aluminium

Plain bearing:

Plastic

Free of copper, PTFE and silicone

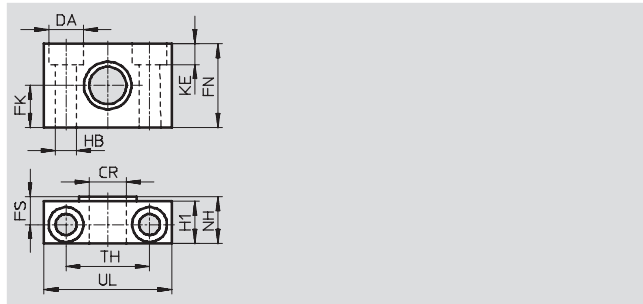

Dimensions and ordering data															
For $\varnothing$	CR	DA	FK	FN	FS	H1	HB	KE	NH	TH	UL	CRC <sup>1)</sup>	Weight	Part No.	Type
[mm]	$\varnothing$ D11	$\varnothing$ H13	$\varnothing$ $\pm 0.1$				$\varnothing$ H13			$\pm 0.2$			[g]		
40	16	15	18	36	12	18	9	9	21	36	55	2	400	<b>32 960</b>	<b>LNZG-40/50</b>
63	20	18	20	40	13	20	11	11	23	42	65	2	480	<b>32 961</b>	<b>LNZG-63/80</b>
100	25	20	25	50	16	24.5	14	13	28.5	50	75	2	960	<b>32 962</b>	<b>LNZG-100/125</b>

1) Corrosion resistance class 2 according to Festo standard 940 070  
 Components requiring moderate corrosion resistance. Externally visible parts with primarily decorative surface requirements which are in direct contact with a normal industrial environment or media such as coolants or lubricating agents.

## Swivel flange SNC

Material:

Die-cast aluminium

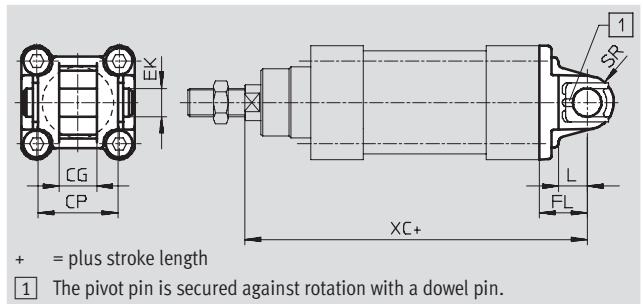

Dimensions and ordering data											
For $\varnothing$	CG	CP	EK	FL	L	SR	XC	CRC <sup>1)</sup>	Weight	Part No.	Type
[mm]	H14	d12	$\varnothing$	$\pm 0.2$					[g]		
40	16	40	12	25	16	12	302	2	120	<b>174 384</b>	<b>SNC-40</b>
63	21	51	16	32	21	16	347	2	320	<b>174 386</b>	<b>SNC-63</b>
100	25	75	20	41	27	20	449	2	830	<b>174 388</b>	<b>SNC-100</b>

1) Corrosion resistance class 2 according to Festo standard 940 070  
 Components requiring moderate corrosion resistance. Externally visible parts with primarily decorative surface requirements which are in direct contact with a normal industrial environment or media such as coolants or lubricating agents.



# Clamping-unit cylinders, standard port pattern

Accessories

## Swivel flange SNCB

Material:  
Die-cast aluminium  
Free of copper, PTFE and silicone

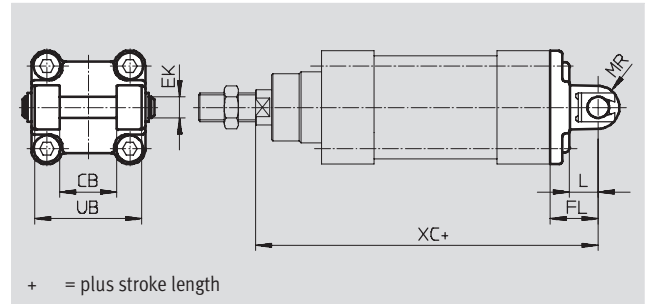

Dimensions and ordering data												
For Ø	CB	EK	FL	L	ML	MR	UB	XC	CRC <sup>1)</sup>	Weight	Part No.	Type
[mm]	H14	Ø e8	+0.2				h14			[g]		
40	28	12	25	16	63	12	52	302	2	150	<b>174 391</b>	<b>SNCB-40</b>
63	40	16	32	21	83	16	70	347	2	365	<b>174 393</b>	<b>SNCB-63</b>
100	60	20	41	27	127	20	110	449	2	925	<b>174 395</b>	<b>SNCB-100</b>

1) Corrosion resistance class 2 according to Festo standard 940 070  
Components requiring moderate corrosion resistance. Externally visible parts with primarily decorative surface requirements which are in direct contact with a normal industrial environment or media such as coolants or lubricating agents.

## Swivel flange SNCS

Material:  
Die-cast aluminium

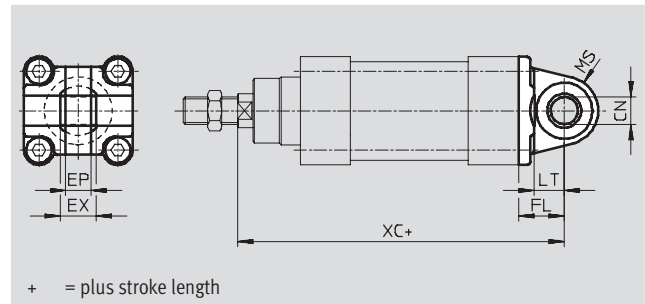
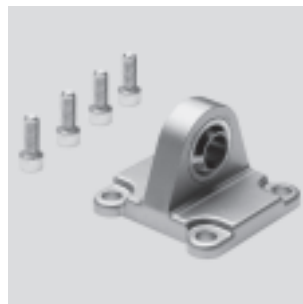

Dimensions and ordering data												
For Ø	CN	EP	EX	FL	LT	MS	XC	CRC <sup>1)</sup>	Weight	Part No.	Type	
[mm]	Ø H7	+0.2		+0.2					[g]			
40	12	12	16	25	16	17	302	2	125	<b>174 398</b>	<b>SNCS-40</b>	
63	16	15	21	32	21	22	347	2	280	<b>174 400</b>	<b>SNCS-63</b>	
100	20	18	25	41	27	29	449	2	700	<b>174 402</b>	<b>SNCS-100</b>	

1) Corrosion resistance class 2 according to Festo standard 940 070  
Components requiring moderate corrosion resistance. Externally visible parts with primarily decorative surface requirements which are in direct contact with a normal industrial environment or media such as coolants or lubricating agents.

# Clamping-unit cylinders, standard port pattern

Accessories



## Swivel flange SNCL

Material:  
Die-cast aluminium  
Free of copper, PTFE and silicone

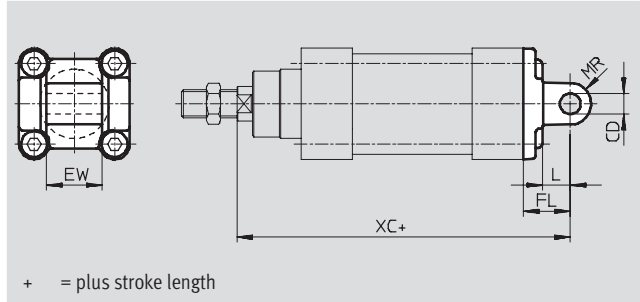
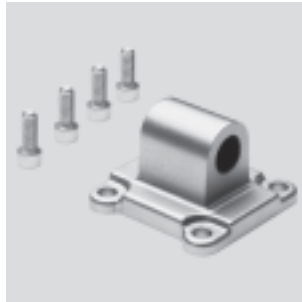

Dimensions and ordering data										
For Ø	CD	EW	FL	L	MR	XC	CRC <sup>1)</sup>	Weight	Part No.	Type
[mm]	Ø	h12	±0.2					[g]		
40	12	28	25	16	12	302	2	100	174 405	SNCL-40
63	16	40	32	21	16	347	2	250	174 407	SNCL-63
100	20	60	41	27	20	449	2	655	174 409	SNCL-100





1) Corrosion resistance class 2 according to Festo standard 940 070  
Components requiring moderate corrosion resistance. Externally visible parts with primarily decorative surface requirements which are in direct contact with a normal industrial environment or media such as coolants or lubricating agents.

Ordering data – Mounting attachments				Technical data → 1 / 10.1-2			
Designation	For Ø	Part No.	Type	Designation	For Ø	Part No.	Type
<b>Clevis foot LNG</b>				<b>Clevis foot LSN</b>			
	40	33 891	LNG-40		40	5 562	LSN-40
	63	33 893	LNG-63		63	5 564	LSN-63
	100	33 895	LNG-100		100	5 566	LSN-100
<b>Clevis foot LSNG</b>				<b>Clevis foot LSNSG</b>			
	40	31 741	LSNG-40		40	31 748	LSNSG-40
	63	31 743	LSNG-63		63	31 750	LSNSG-63
	100	31 745	LSNG-100		100	31 752	LSNSG-100
<b>Clevis foot LBG</b>				<b>Clevis foot, right-angled LQG</b>			
	40	31 762	LBG-40		40	31 769	LQG-40
	63	31 764	LBG-63		63	31 771	LQG-63
	100	31 766	LBG-100		100	31 773	LQG-100

# Clamping-unit cylinders, standard port pattern

Accessories

FESTO

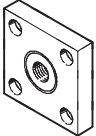
Ordering data – Piston rod attachments				Technical data → 1 / 10.3-2			
Designation	For Ø	Part No.	Type	Designation	For Ø	Part No.	Type
<b>Rod eye SGS</b>				<b>Rod clevis SGA</b>			
	40	9 262	SGS-M12x1,25		40	10 767	SGA-M12x1,25
	63	9 263	SGS-M16x1,5		63	10 768	SGA-M16x1,5
	100	9 264	SGS-M20x1,5		100	10 769	SGA-M20x1,5
<b>Rod clevis SG</b>				<b>Self-aligning rod coupler FK</b>			
	40	6 145	SG-M12x1,25		40	6 141	FK-M12x1,25
	63	6 146	SG-M16x1,5		63	6 142	FK-M16x1,5
	100	6 147	SG-M20x1,5		100	6 143	FK-M20x1,5
<b>Coupling piece KSG</b>							
	40	32 964	KSG-M12x1,25				
	63	32 965	KSG-M16x1,5				
	100	32 966	KSG-M20x1,5				

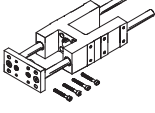
Ordering data – Guide units for fixed strokes (recirculating ball bearing guide only)				Technical data → 1 / 10.4-2			
	Stroke [mm]	Part No.	Type	Stroke [mm]	Part No.	Type	
	For Ø 40 mm			For Ø 63 mm			
	10 ... 50	34 499	FENG-40-50-KF	10 ... 50	34 513	FENG-63-50-KF	
	10 ... 100	34 500	FENG-40-100-KF	10 ... 100	34 514	FENG-63-100-KF	
	10 ... 160	34 501	FENG-40-160-KF	10 ... 160	34 515	FENG-63-160-KF	
	10 ... 200	34 502	FENG-40-200-KF	10 ... 200	34 516	FENG-63-200-KF	
	10 ... 250	34 503	FENG-40-250-KF	10 ... 250	34 517	FENG-63-250-KF	
	10 ... 320	34 504	FENG-40-320-KF	10 ... 320	34 518	FENG-63-320-KF	
	10 ... 400	150 291	FENG-40-400-KF	10 ... 400	34 519	FENG-63-400-KF	
	10 ... 500	34 505	FENG-40-500-KF	10 ... 500	34 520	FENG-63-500-KF	
	For Ø 100 mm						
	10 ... 50	34 529	FENG-100-50-KF				
	10 ... 100	34 530	FENG-100-100-KF				
	10 ... 160	34 531	FENG-100-160-KF				
	10 ... 200	34 532	FENG-100-200-KF				
	10 ... 250	34 533	FENG-100-250-KF				
	10 ... 320	34 534	FENG-100-320-KF				
	10 ... 400	34 535	FENG-100-400-KF				
	10 ... 500	34 536	FENG-100-500-KF				

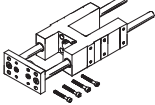
Ordering data – Guide units for variable strokes				Technical data → 1 / 10.4-2			
	For Ø [mm]	Stroke [mm]	with recirculating ball bearing guide	with plain bearing guide			
			Part No.	Type	Part No.	Type	
	40	10 ... 500	34 488	FENG-40-...-KF	34 482	FENG-40-...	
	63	10 ... 500	34 490	FENG-63-...-KF	34 484	FENG-63-...	
	100	10 ... 500	34 492	FENG-100-...-KF	34 486	FENG-100-...	

Special-function drives  
Clamping cylinders



5.11

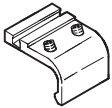

# Clamping-unit cylinders, standard port pattern

FESTO

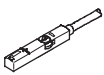
Accessories

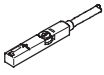
Ordering data – Mounting kit for proximity sensor SMT-8		Technical data → <a href="http://www.festo.com/catalogue/smb">www.festo.com/catalogue/smb</a>	
	For Ø [mm]	Part No.	Type
	40	175 705	SMB-8-FENG-32/40
	63	175 706	SMB-8-FENG-50/63
	100	175 707	SMB-8-FENG-80/100

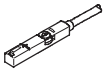

Ordering data – Proximity switches for T-slot, magneto-resistive					Technical data → <a href="http://www.festo.com/catalogue/sm">www.festo.com/catalogue/sm</a>	
	Type of mounting	Switch output	Electrical connection	Cable length [m]	Part No.	Type
<b>N/O contact</b>						
	Insertable in the slot from above, flush with cylinder profile	PNP	Cable, 3-wire	2,5	543 867	SMT-8M-PS-24V-K-2,5-OE
			Plug M8x1, 3-pin	0,3	543 866	SMT-8M-PS-24V-K-0,3-M8D
			Plug M12x1, 3-pin	0,3	543 869	SMT-8M-PS-24V-K-0,3-M12
		NPN	Cable, 3-wire	2,5	543 870	SMT-8M-NS-24V-K-2,5-OE
Plug M8x1, 3-pin	0,3		543 871	SMT-8M-NS-24V-K-0,3-M8D		
	Insertable in the slot lengthwise, flush with the cylinder profile	PNP	Cable, 3-wire	2,5	175 436	SMT-8-PS-K-LED-24-B
			Plug M8x1, 3-pin	0,3	175 484	SMT-8-PS-S-LED-24-B
<b>N/C contact</b>						
	Insertable in the slot from above, flush with cylinder profile	PNP	Cable, 3-wire	7,5	543 873	SMT-8M-PO-24V-K7,5-OE

Ordering data – Proximity switches for T-slot, magnetic reed					Technical data → <a href="http://www.festo.com/catalogue/sm">www.festo.com/catalogue/sm</a>	
	Type of mounting	Switch output	Electrical connection	Cable length [m]	Part No.	Type
<b>N/O contact</b>						
	Insertable in the slot from above, flush with cylinder profile	Contacting	Cable, 3-wire	2,5	543 862	SME-8M-DS-24V-K-2,5-OE
				5,0	543 863	SME-8M-DS-24V-K-5,0-OE
			Cable, 3-wire	2,5	543 872	SME-8M-ZS-24V-K-2,5-OE
			Plug M8x1, 3-pin	0,3	543 861	SME-8M-DS-24V-K-0,3-M8D
	Insertable in the slot lengthwise, flush with the cylinder profile	Contacting	Cable, 3-wire	2,5	150 855	SME-8-K-LED-24
			Plug M8x1, 3-pin	0,3	150 857	SME-8-S-LED-24
<b>N/C contact</b>						
	Insertable in the slot lengthwise, flush with the cylinder profile	Contacting	Cable, 3-wire	7,5	160 251	SME-8-O-K-LED-24

# Clamping-unit cylinders, standard port pattern

Accessories

FESTO

Ordering data – Connecting cable				Technical data → <a href="http://www.festo.com/catalogue/nebu">www.festo.com/catalogue/nebu</a>	
	Electrical connection, left	Electrical connection, right	Cable length [m]	Part No.	Type
	Straight socket, M8x1, 3-pin	Cable, open end, 3-wire	2,5	541 333	NEBU-M8G3-K-2.5-LE3
			5	541 334	NEBU-M8G3-K-5-LE3
	Straight socket, M12x1, 5-pin	Cable, open end, 3-wire	2,5	541 363	NEBU-M12G5-K-2.5-LE3
			5	541 364	NEBU-M12G5-K-5-LE3
	Angled socket, M8x1, 3-pin	Cable, open end, 3-wire	2,5	541 338	NEBU-M8W3-K-2.5-LE3
			5	541 341	NEBU-M8W3-K-5-LE3
	Angled socket, M12x1, 5-pin	Cable, open end, 3-wire	2,5	541 367	NEBU-M12W5-K-2.5-LE3
			5	541 370	NEBU-M12W5-K-5-LE3

Ordering data – Slot cover for T-slot				Part No.	Type
	Assembly	Length [m]			
	Insertable from above	2x 0.5		151 680	ABP-5-S

Ordering data – One-way flow control valves				Technical data → Volume 2	
	Connection		Material	Part No.	Type
	Thread	For tubing OD			
	G $\frac{1}{8}$	3	Metal design	193 142	GRLA- $\frac{1}{8}$ -QS-3-D
		4		193 143	GRLA- $\frac{1}{8}$ -QS-4-D
		6		193 144	GRLA- $\frac{1}{8}$ -QS-6-D
		8		193 145	GRLA- $\frac{1}{8}$ -QS-8-D
	G $\frac{1}{4}$	6		193 146	GRLA- $\frac{1}{4}$ -QS-6-D
		8		193 147	GRLA- $\frac{1}{4}$ -QS-8-D
		10		193 148	GRLA- $\frac{1}{4}$ -QS-10-D
	G $\frac{3}{8}$	6		193 149	GRLA- $\frac{3}{8}$ -QS-6-D
		8		193 150	GRLA- $\frac{3}{8}$ -QS-8-D
		10		193 151	GRLA- $\frac{3}{8}$ -QS-10-D
	G $\frac{1}{2}$	12		193 152	GRLA- $\frac{1}{2}$ -QS-12-D