



- Economical standard cylinder without variants
- Profile slot for proximity sensors and air connections on one side
- Choice of mounting options
- Stroke of up to 2,000 mm
- Wide range of accessories

Standard cylinders DNCB, ISO 15552

Features



At a glance



- Standards-based cylinders to ISO 15552 (corresponds to the withdrawn standards ISO 6431, DIN ISO 6431, VDMA 24 562, NF E 49 003.1 and UNI 10290)
- The modern design and construction saves up to 11% on space compared to ordinary standard cylinders, thus permitting a considerably more compact system design



DIN



High quality product

- Proven technology, compact, solid and reliable
- Excellent running characteristics thanks to efficient piston system
- Simple and sensitive adjustable end-position cushioning thanks to new PPV adjusting screw
- When an ideal setting has been found, the imprinted scale ensures easy reproducibility

Contactless sensing

- The proximity sensors fit flush in the profile slot. On the one hand, this does away with the need for additional mounting kits and on the other, it protects the proximity sensor against mechanical damage

Easy to assemble

- Large selection of mounting options
- All accessories and mounting attachments from the DNC range can be used

Accessories

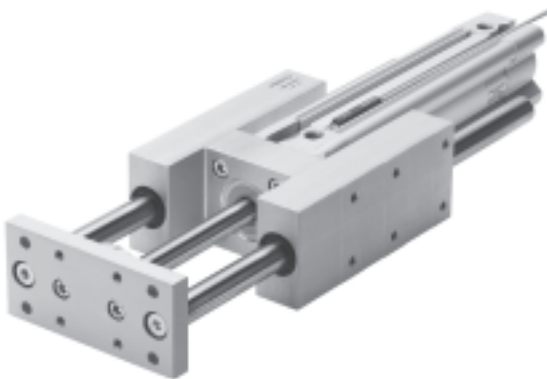

Guide units protect ISO standard cylinders from torsion when these are subjected to high torque loads. They provide high precision guidance for workpiece handling and other handling applications.

Standard cylinders DNCB, ISO 15552

Type codes

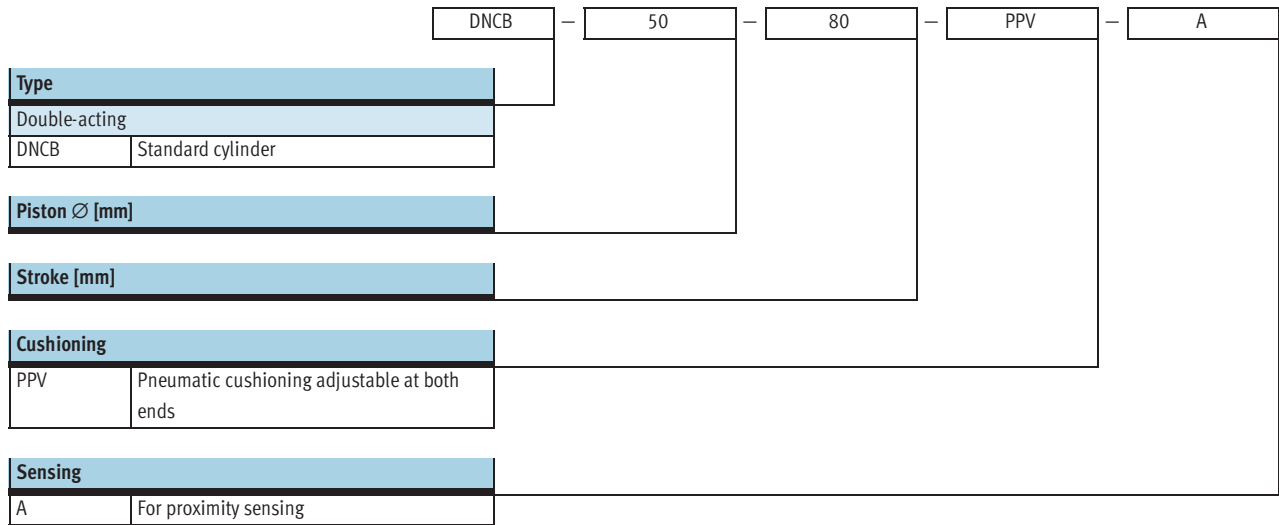

Standard cylinders DNCB, ISO 15552

Peripherals overview



ISO standard cylinders
ISO 15552 (ISO 6431 and VDMA 24562)

1.2

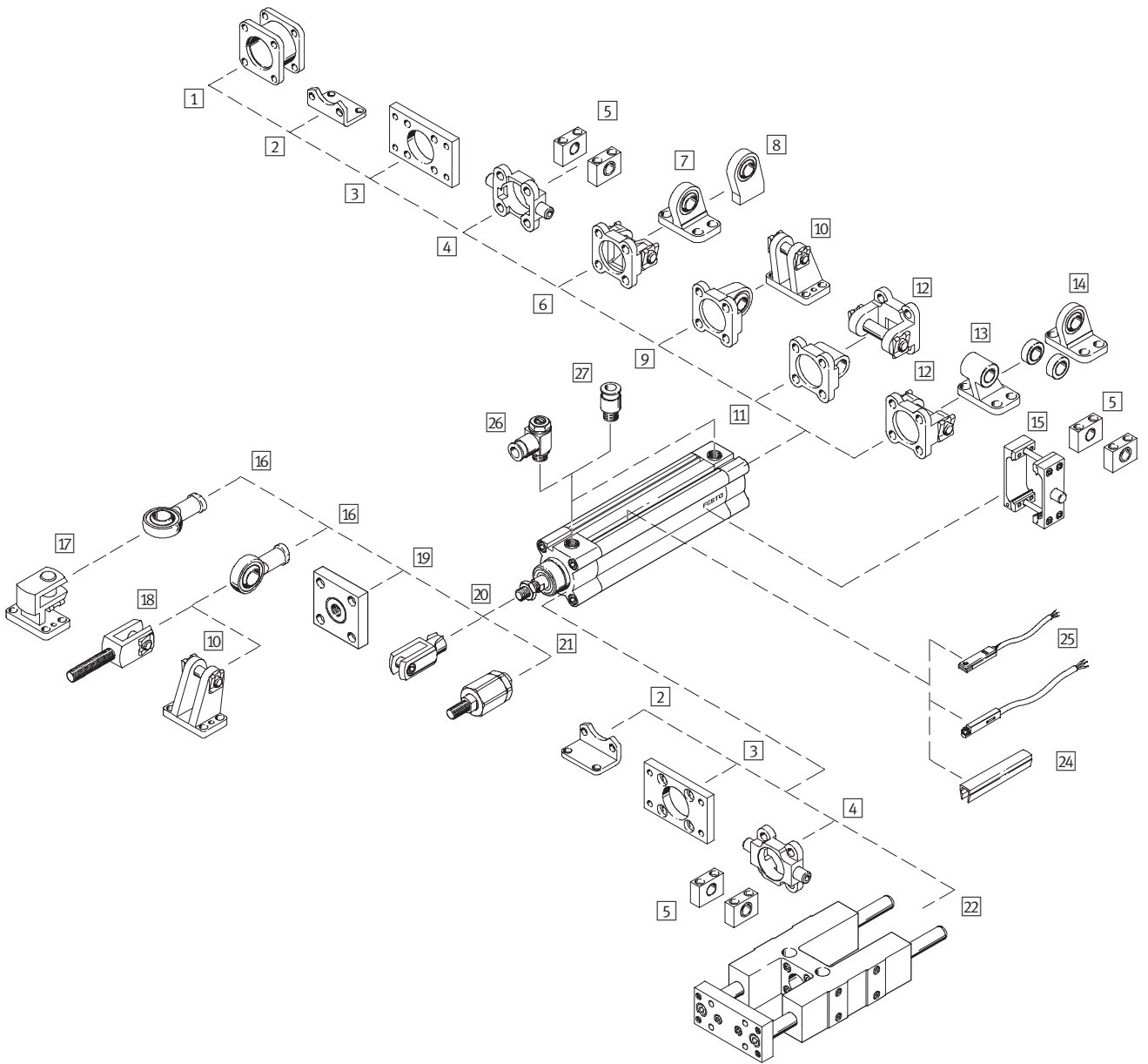

Standard cylinders DNCB, ISO 15552

Peripherals overview

FESTO

Mounting attachments and accessories		
	Brief description	→ Page
1	Multi-position kit DPNC	for connecting two DNCB cylinders with identical piston \varnothing to form a multi-position cylinder 1 / 1.2-10
2	Foot mounting HNC	for bearing and end caps corresponds to MS1 to ISO 15552 1 / 1.2-11
3	Flange mounting FNC	for bearing or end caps corresponds to MF1/MF2 to ISO 15552 1 / 1.2-11
4	Trunnion flange ZNCF	for bearing or end caps 1 / 1.2-12
5	Trunnion support LNZG	corresponds to MT4 to ISO 15552 1 / 1.2-14
6	Swivel flange SNC	for end caps 1 / 1.2-14
7	Clevis foot LSNG	with spherical bearing 1 / 1.2-16
8	Clevis foot LSNSG	weld-on with spherical bearing 1 / 1.2-16
9	Swivel flange SNCS	with spherical bearing for end caps 1 / 1.2-15
10	Clevis foot LBG	with non-rotating pivot pin 1 / 1.2-16
11	Swivel flange SNCL	for end caps corresponds to MP4 to ISO 15552 1 / 1.2-16
12	Swivel flange SNCB	for end caps corresponds to MP2 to ISO 15552 1 / 1.2-15
13	Clevis foot LNG	for swivel flange SNCB 1 / 1.2-16
14	Clevis foot LSN	with spherical bearing 1 / 1.2-16
15	Trunnion mounting kit ZNCM	for mounting anywhere on the cylinder barrel corresponds to MT4 to ISO 15552 1 / 1.2-13
16	Rod eye SGS	with spherical bearing 1 / 1.2-17
17	Right-angle clevis foot LQG	with non-rotating pivot pin for rod eye SGS 1 / 1.2-16
18	Rod clevis SGA	suitable for spherical mounting of cylinders in conjunction with rod eye SGS 1 / 1.2-17
19	Coupling piece KSG	for compensating radial deviations 1 / 1.2-17
20	Rod clevis SG	permits a swivelling movement of the cylinder in one plane 1 / 1.2-17
21	Self-aligning rod coupler FK	for compensating radial and angular deviations 1 / 1.2-17
22	Guide unit FENG	to protect against torsion at high torque loads 1 / 1.2-18
24	Slot cover ABP-5-S	to protect the sensor cable and keep dirt out of the sensor slots 1 / 1.2-19
25	Proximity sensors SME/SMT-8	can be integrated in the cylinder profile barrel 1 / 1.2-19
26	One-way flow control valve GRLA	for speed regulation 1 / 1.2-17
27	Push-in fitting QS	for connecting compressed air tubing with standard O.D. Volume 3

ISO standard cylinders
ISO 15552 (ISO 6431 and VDMA 24562)

1.2

Standard cylinders DNCB, ISO 15552

Technical data



Function

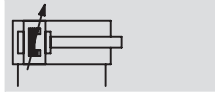

DIN



⊘ - Diameter
32 ... 100 mm

- | - Stroke length
2 ... 2,000 mm



[www.festo.com/en/
Spare_parts_service](http://www.festo.com/en/Spare_parts_service)

Wearing parts kits

➔ 1 / 1.2-9

General technical data						
Piston ∅	32	40	50	63	80	100
Pneumatic connection	G $\frac{1}{8}$	G $\frac{1}{4}$	G $\frac{1}{4}$	G $\frac{3}{8}$	G $\frac{3}{8}$	G $\frac{1}{2}$
Piston rod thread	M10x1.25	M12x1.25	M16x1.5	M16x1.5	M20x1.5	M20x1.5
Constructional design	Piston					
	Piston rod					
	Profile barrel					
Cushioning	Pneumatic cushioning adjustable at both ends					
Cushioning length [mm]	20	20	22	22	32	32
Position sensing	For proximity sensing					
Type of mounting	Using internal threads					
	With accessories					
Mounting position	Any					

Operating and environmental conditions	
Operating medium	Filtered compressed air, lubricated or unlubricated
Operating pressure [bar]	0.6 ... 12
Ambient temperature ¹⁾ [°C]	-20 ... +80
Corrosion resistance class CRC ²⁾	2

1) Note operating range of proximity sensors

2) Corrosion resistance class 2 according to Festo standard 940 070

Components requiring moderate corrosion resistance. Externally visible parts with primarily decorative surface requirements which are in direct contact with a surrounding industrial atmosphere or media such as cooling or lubricating agents

Forces [N] and impact energy [J]						
Piston ∅	32	40	50	63	80	100
Theoretical force at 6 bar, advancing	483	754	1,178	1,870	3,016	4,712
Theoretical force at 6 bar, retracting	415	633	990	1,682	2,721	4,418
Max. impact energy at end positions	0.4	0.7	1	1.3	2	3



Pneumatic sizing using Pro Pneu
www.festo.com/en/engineering

Standard cylinders DNCB, ISO 15552

Technical data



Lateral force F_q as a function of stroke length l

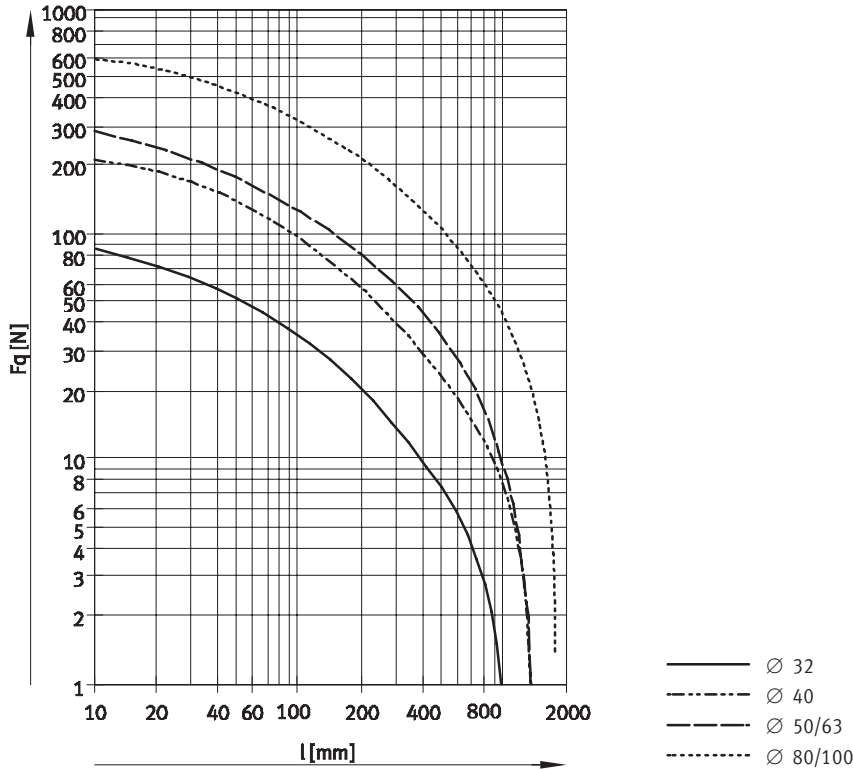

Weights [g]						
Piston Ø	32	40	50	63	80	100
Product weight with 0 mm stroke	460	760	1,225	1,800	3,135	4,575
Additional weight per 10 mm stroke	27	37	56	62	92	101
Moving load with 0 mm stroke	108	204	363	460	800	1,045
Additional load per 10 mm stroke	9	16	25	25	39	39

Materials

Sectional view

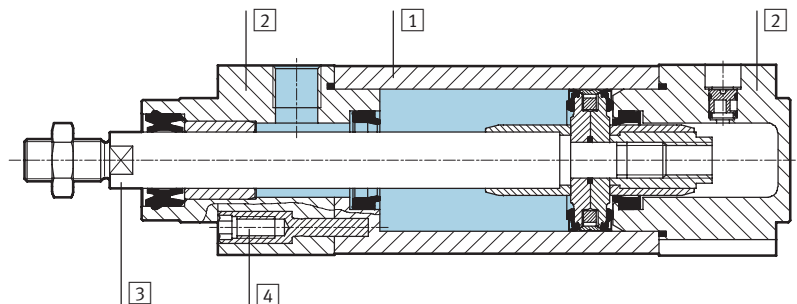

Standard cylinder	
1	Cylinder barrel Anodised aluminium
2	Bearing/end caps Die-cast aluminium
3	Piston rod High-alloy steel
4	Flange screws Galvanised steel
-	Seals Polyurethane, nitrile rubber
	Note on material Free of copper, PTFE and silicone

Standard cylinders DNCB, ISO 15552

Technical data



ISO standard cylinders
ISO 15552 (ISO 6431 and VDMA 24562)

Dimensions Download CAD data → www.festo.com/en/engineering

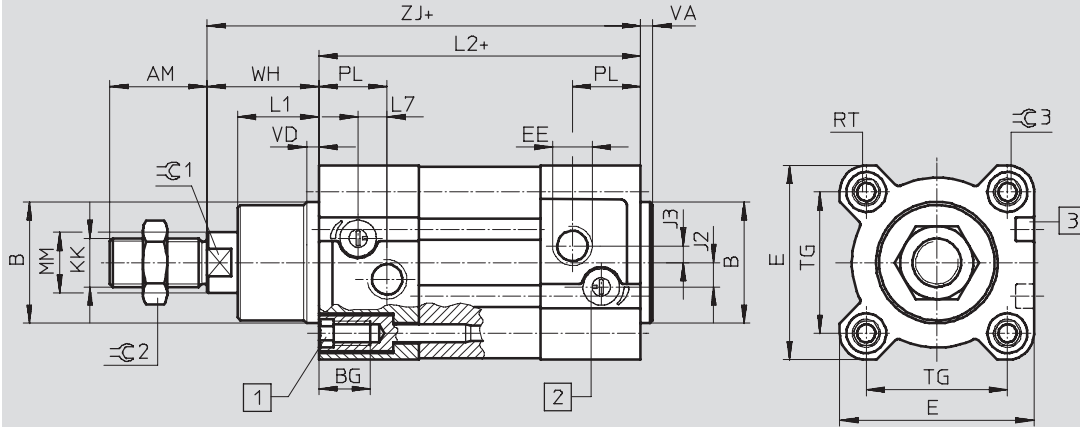

- 1 Socket head screw with female thread for mounting attachments
- 2 Regulating screw for adjustable end-position cushioning
- 3 Sensor slot for proximity sensor SME/SMT-8
- + = plus stroke length

∅	AM	B ∅ d11	BG	E	EE	J2	J3	KK	L1	L2	L7
32	22	30	16	45	G1/8	5.25	5.7	M10x1.25	18	94	6.5
40	24	35	16	54	G1/4	8	4	M12x1.25	21.3	105	7.5
50	32	40	17	64	G1/4	8	5.5	M16x1.5	26.8	106	9.5
63	32	45	17	75	G3/8	12.75	6.25	M16x1.5	27	121	9
80	40	45	17	93	G3/8	12.5	8	M20x1.5	34.2	128	11
100	40	55	17	110	G1/2	13.5	10	M20x1.5	38	138	7.5

∅	MM ∅	PL	RT	TG	VA	VD	WH	ZJ	∅1	∅2	∅3
32	12	19.5	M6	32.5	4	4	26	120	10	16	6
40	16	22.5	M6	38	4	4	30	135	13	18	6
50	20	22.5	M8	46.5	4	4	37	143	17	24	8
63	20	27.5	M8	56.5	4	4	37	158	17	24	8
80	25	30	M10	72	4	4	46	174	22	30	6
100	25	31.5	M10	89	4	4	51	189	22	30	6

Standard cylinders DNCB, ISO 15552

Technical data

FESTO

Ordering data																	
Piston Ø 32 mm			Piston Ø 40 mm			Piston Ø 50 mm			Piston Ø 63 mm			Piston Ø 80 mm			Piston Ø 100 mm		
Stroke [mm]	Part No.	Type	Part No.	Type	Part No.	Type	Part No.	Type	Part No.	Type	Part No.	Type	Part No.	Type	Part No.	Type	
25	532 724	DNCB-32-25-PPV-A	532 737	DNCB-40-25-PPV-A	532 750	DNCB-50-25-PPV-A	532 763	DNCB-63-25-PPV-A	532 884	DNCB-80-25-PPV-A	532 897	DNCB-100-25-PPV-A					
40	532 725	DNCB-32-40-PPV-A	532 738	DNCB-40-40-PPV-A	532 751	DNCB-50-40-PPV-A	532 764	DNCB-63-40-PPV-A	532 885	DNCB-80-40-PPV-A	532 898	DNCB-100-40-PPV-A					
50	532 726	DNCB-32-50-PPV-A	532 739	DNCB-40-50-PPV-A	532 752	DNCB-50-50-PPV-A	532 765	DNCB-63-50-PPV-A	532 886	DNCB-80-50-PPV-A	532 899	DNCB-100-50-PPV-A					
80	532 727	DNCB-32-80-PPV-A	532 740	DNCB-40-80-PPV-A	532 753	DNCB-50-80-PPV-A	532 766	DNCB-63-80-PPV-A	532 887	DNCB-80-80-PPV-A	532 900	DNCB-100-80-PPV-A					
100	532 728	DNCB-32-100-PPV-A	532 741	DNCB-40-100-PPV-A	532 754	DNCB-50-100-PPV-A	532 767	DNCB-63-100-PPV-A	532 888	DNCB-80-100-PPV-A	532 901	DNCB-100-100-PPV-A					
125	532 729	DNCB-32-125-PPV-A	532 742	DNCB-40-125-PPV-A	532 755	DNCB-50-125-PPV-A	532 768	DNCB-63-125-PPV-A	532 889	DNCB-80-125-PPV-A	532 902	DNCB-100-125-PPV-A					
160	532 730	DNCB-32-160-PPV-A	532 743	DNCB-40-160-PPV-A	532 756	DNCB-50-160-PPV-A	532 769	DNCB-63-160-PPV-A	532 890	DNCB-80-160-PPV-A	532 903	DNCB-100-160-PPV-A					
200	532 731	DNCB-32-200-PPV-A	532 744	DNCB-40-200-PPV-A	532 757	DNCB-50-200-PPV-A	532 770	DNCB-63-200-PPV-A	532 891	DNCB-80-200-PPV-A	532 904	DNCB-100-200-PPV-A					
250	532 732	DNCB-32-250-PPV-A	532 745	DNCB-40-250-PPV-A	532 758	DNCB-50-250-PPV-A	532 771	DNCB-63-250-PPV-A	532 892	DNCB-80-250-PPV-A	532 905	DNCB-100-250-PPV-A					
320	532 733	DNCB-32-320-PPV-A	532 746	DNCB-40-320-PPV-A	532 759	DNCB-50-320-PPV-A	532 772	DNCB-63-320-PPV-A	532 893	DNCB-80-320-PPV-A	532 906	DNCB-100-320-PPV-A					
400	532 734	DNCB-32-400-PPV-A	532 747	DNCB-40-400-PPV-A	532 760	DNCB-50-400-PPV-A	532 773	DNCB-63-400-PPV-A	532 894	DNCB-80-400-PPV-A	532 907	DNCB-100-400-PPV-A					
500	532 735	DNCB-32-500-PPV-A	532 748	DNCB-40-500-PPV-A	532 761	DNCB-50-500-PPV-A	532 774	DNCB-63-500-PPV-A	532 895	DNCB-80-500-PPV-A	532 908	DNCB-100-500-PPV-A					

Ordering data – Variable stroke			
Piston Ø [mm]	Stroke [mm]	Part No.	Type
32	2 ... 2,000	532 723	DNCB-32-...-PPV-A
40	2 ... 2,000	532 736	DNCB-40-...-PPV-A
50	2 ... 2,000	532 749	DNCB-50-...-PPV-A
63	3 ... 2,000	532 762	DNCB-63-...-PPV-A
80	3 ... 2,000	532 883	DNCB-80-...-PPV-A
100	3 ... 2,000	532 896	DNCB-100-...-PPV-A

Ordering data – Wearing parts kits ¹⁾			
Piston Ø [mm]	Part No.	Type	
32	665 294	DNCB-32-PPV-A	
40	665 295	DNCB-40-PPV-A	
50	665 296	DNCB-50-PPV-A	
63	665 297	DNCB-63-PPV-A	
80	665 298	DNCB-80-PPV-A	
100	665 299	DNCB-100-PPV-A	

1) Assembly grease included in scope of delivery

Standard cylinders DNCB, ISO 15552

Accessories



Multi-position kit DPNC

Material:
Flange: Wrought aluminium alloy
threaded pins, hex nuts: Galvanised steel

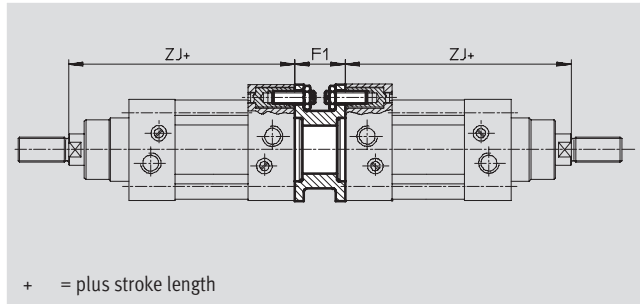
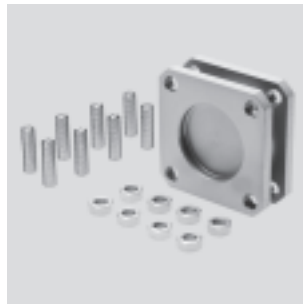

Dimensions and ordering data						
For \varnothing [mm]	F1	ZJ	Max. overall stroke length [mm]	Weight [g]	Part No.	Type
32	27	120	1,000	85	174 418	DPNC-32
40	27	135	1,000	115	174 419	DPNC-40
50	32	143	1,000	210	174 420	DPNC-50
63	28	158	1,000	360	174 421	DPNC-63
80	38	174	1,000	620	174 422	DPNC-80
100	38	189	1,000	1,190	174 423	DPNC-100

 Note
The maximum overall stroke length may not be exceeded when combining cylinders and the multi-position kit.

ISO standard cylinders
ISO 15552 (ISO 6431 and VDMA 24562)
1.2

Connecting two cylinders with identical piston \varnothing as a 3 or 4-position cylinder.

A 3 or 4-position cylinder consists of two separate cylinders whose piston rods advance in opposing directions.

Depending upon actuation and stroke pattern, this type of cylinder can assume up to four positions. In each

case the cylinder is driven precisely against a stop. If one end of the piston rod is fixed, the cylinder barrel

executes the movement. The cylinder must be connected with flexible line connections.

Implementing 3 positions

Two cylinders with identical stroke length must be connected to this end.

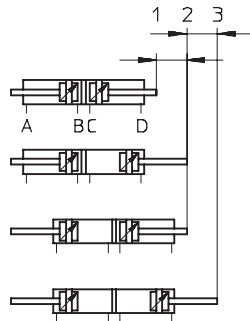

Implementing 4 positions

Two cylinders with different stroke lengths must be connected to this end.

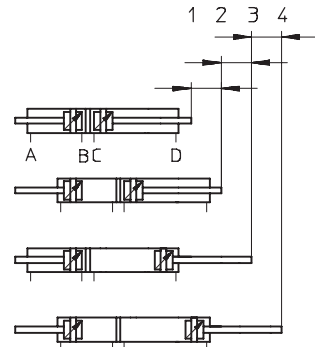

Standard cylinders DNCB, ISO 15552



Accessories

Foot mounting HNC

Material:
Galvanised steel
Free of copper, PTFE and silicone

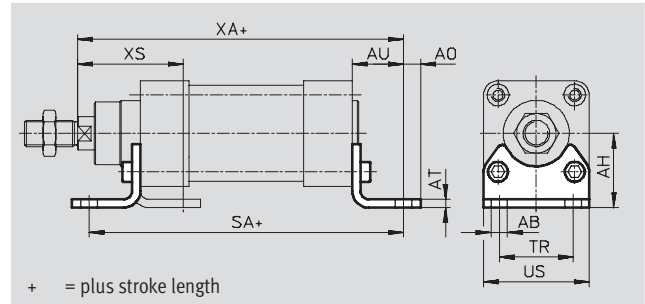

Dimensions and ordering data														
For \varnothing	AB	AH	AO	AT	AU	SA	TR	US	XA	XS	CRC ¹⁾	Weight	Part No.	Type
[mm]	\varnothing											[g]		
32	7	32	6.5	4	24	142	32	45	144	45	2	135	174 369	HNC-32
40	10	36	9	4	28	161	36	54	163	53	2	180	174 370	HNC-40
50	10	45	9.5	5	32	170	45	64	175	62	2	325	174 371	HNC-50
63	10	50	12.5	5	32	185	50	75	190	63	2	405	174 372	HNC-63
80	12	63	15	6	41	210	63	93	215	81	2	820	174 373	HNC-80
100	14.5	71	17.5	6	41	220	75	110	230	86	2	1,000	174 374	HNC-100

1) Corrosion resistance class 2 according to Festo standard 940 070

Components requiring moderate corrosion resistance. Externally visible parts with primarily decorative surface requirements which are in direct contact with a surrounding industrial atmosphere or media such as cooling or lubricating agents

Flange mounting FNC

Material:
Galvanised steel
Free of copper, PTFE and silicone

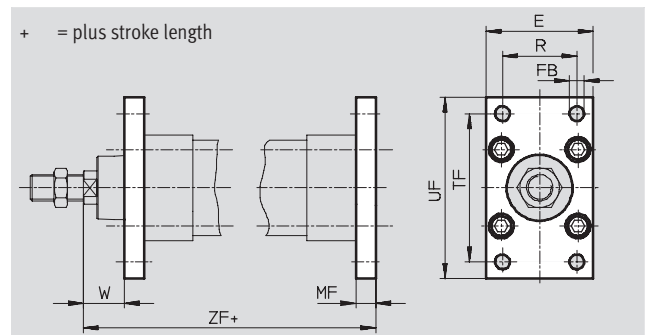

Dimensions and ordering data													
For \varnothing	E	FB	MF	R	TF	UF	W	ZF	CRC ¹⁾	Weight	Part No.	Type	
[mm]		\varnothing H13								[g]			
32	45	7	10	32	64	80	16	130	2	240	174 376	FNC-32	
40	54	9	10	36	72	90	20	145	2	280	174 377	FNC-40	
50	65	9	12	45	90	110	25	155	2	520	174 378	FNC-50	
63	75	9	12	50	100	120	25	170	2	690	174 379	FNC-63	
80	93	12	16	63	126	150	30	190	2	1,650	174 380	FNC-80	
100	110	14	16	75	150	175	35	205	2	2,400	174 381	FNC-100	

1) Corrosion resistance class 2 according to Festo standard 940 070

Components requiring moderate corrosion resistance. Externally visible parts with primarily decorative surface requirements which are in direct contact with a surrounding industrial atmosphere or media such as cooling or lubricating agents

Standard cylinders DNCB, ISO 15552

Accessories



Trunnion flange ZNCF

Material:

Corrosion resistant cast steel
Free of copper, PTFE and silicone

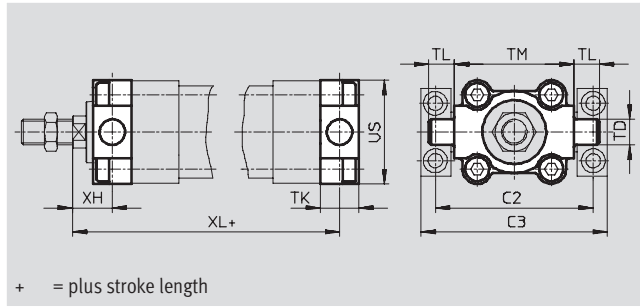
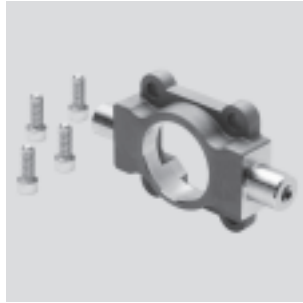

+ = plus stroke length

Dimensions and ordering data

For \varnothing [mm]	C2	C3	TD \varnothing e9	TK	TL	TM	US	XH	XL	CRC ¹⁾	Weight [g]	Part No.	Type
32	71	86	12	16	12	50	45	18	128	2	130	174 411	ZNCF-32
40	87	105	16	20	16	63	54	20	145	2	240	174 412	ZNCF-40
50	99	117	16	24	16	75	64	25	155	2	390	174 413	ZNCF-50
63	116	136	20	24	20	90	75	25	170	2	600	174 414	ZNCF-63
80	136	156	20	28	20	110	93	32	188	2	1,150	174 415	ZNCF-80
100	164	189	25	38	25	132	110	32	208	2	2,030	174 416	ZNCF-100

1) Corrosion resistance class 2 according to Festo standard 940 070

Components requiring moderate corrosion resistance. Externally visible parts with primarily decorative surface requirements which are in direct contact with a surrounding industrial atmosphere or media such as cooling or lubricating agents

Standard cylinders DNCB, ISO 15552



Accessories

Trunnion mounting kit ZNCM

The mounting kit can be attached at any position along the profile of the cylinder barrel.

Material:
Tempered steel

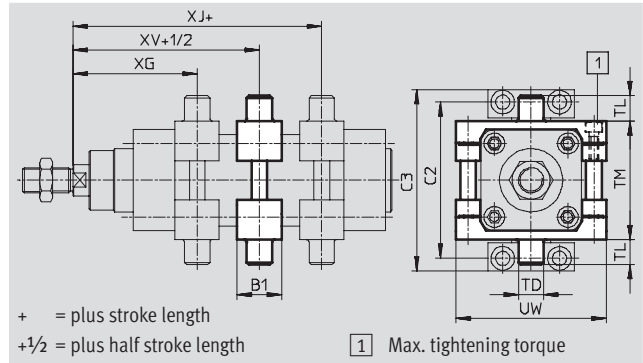

Dimensions and ordering data							
For \varnothing	B1	C2	C3	TD \varnothing e9	TL	TM	UW
[mm]							
32	30	71	86	12	12	50	65
40	32	87	105	16	16	63	75
50	34	99	117	16	16	75	95
63	41	116	136	20	20	90	105
80	44	136	156	20	20	110	130
100	48	164	189	25	25	132	145

For \varnothing	XG	XJ	XV	Max. tightening torque [Nm]	CRC ¹⁾	Weight [g]	Part No.	Type
[mm]								
32	69	73	77	4 +1	2	210	163 525	ZNCM-32
40	79	82.5	86	8 +1	2	385	163 526	ZNCM-40
50	87	90	93	8 +2	2	595	163 527	ZNCM-50
63	98	97.5	100	18 +2	2	890	163 528	ZNCM-63
80	111	110	109	28 +2	2	1,450	163 529	ZNCM-80
100	123	120	117	28 +2	2	2,045	163 530	ZNCM-100

1) Corrosion resistance class 2 according to Festo standard 940 070
Components requiring moderate corrosion resistance. Externally visible parts with primarily decorative surface requirements which are in direct contact with a surrounding industrial atmosphere or media such as cooling or lubricating agents

Standard cylinders DNCB, ISO 15552

Accessories



LNZG trunnion support

Material:

Trunnion support:

Anodised aluminium

Plain bearing: Plastic

Free of copper, PTFE and silicone

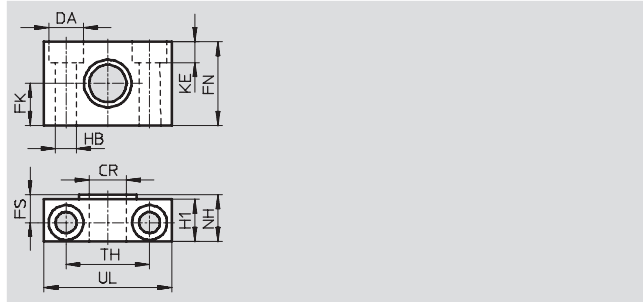

Dimensions and ordering data															
For \varnothing	CR	DA	FK	FN	FS	H1	HB	KE	NH	TH	UL	CRC ¹⁾	Weight	Part No.	Type
[mm]	\varnothing D11	\varnothing H13	\varnothing ± 0.1				\varnothing H13			± 0.2			[g]		
32	12	11	15	30	10.5	15	6.6	6.8	18	32	46	2	125	32 959	LNZG-32
40, 50	16	15	18	36	12	18	9	9	21	36	55	2	400	32 960	LNZG-40/50
63, 80	20	18	20	40	13	20	11	11	23	42	65	2	480	32 961	LNZG-63/80
100	25	20	25	50	16	24.5	14	13	28.5	50	75	2	960	32 962	LNZG-100/125

1) Corrosion resistance class 2 according to Festo standard 940 070

Components requiring moderate corrosion resistance. Externally visible parts with primarily decorative surface requirements which are in direct contact with a surrounding industrial atmosphere or media such as cooling or lubricating agents

Swivel flange SNC

Material:

Die-cast aluminium

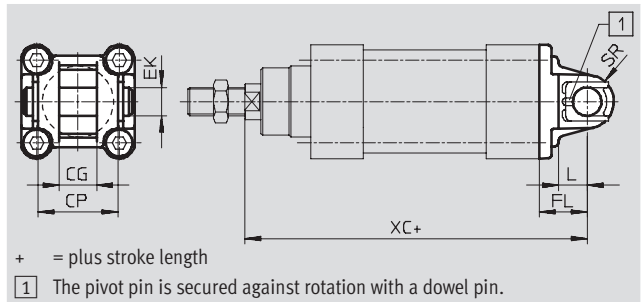

Dimensions and ordering data											
For \varnothing	CG	CP	EK	FL	L	SR	XC	CRC ¹⁾	Weight	Part No.	Type
[mm]	H14	h14	\varnothing	± 0.2					[g]		
32	14	34	10	22	13	10	142	2	90	174 383	SNC-32
40	16	40	12	25	16	12	160	2	120	174 384	SNC-40
50	21	45	16	27	16	12	170	2	240	174 385	SNC-50
63	21	51	16	32	21	16	190	2	320	174 386	SNC-63
80	25	65	20	36	22	20	210	2	625	174 387	SNC-80
100	25	75	20	41	27	20	230	2	830	174 388	SNC-100

1) Corrosion resistance class 2 according to Festo standard 940 070

Components requiring moderate corrosion resistance. Externally visible parts with primarily decorative surface requirements which are in direct contact with a surrounding industrial atmosphere or media such as cooling or lubricating agents

Standard cylinders DNCB, ISO 15552



Accessories

Swivel flange SNCB

Material:
Die-cast aluminium
Free of copper, PTFE and silicone

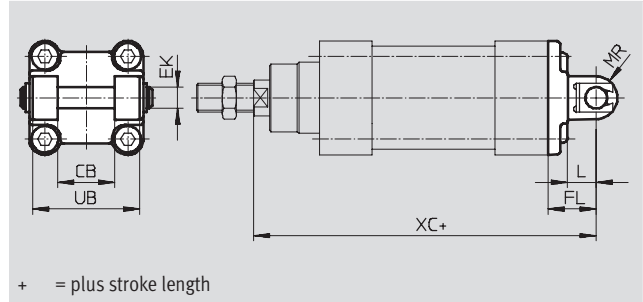

Dimensions and ordering data												
For \varnothing	CB	EK	FL	L	ML	MR	UB	XC	CRC ¹⁾	Weight	Part No.	Type
[mm]	H14	\varnothing e8	± 0.2				h14			[g]		
32	26	10	22	13	55	10	45	142	2	100	174 390	SNCB-32
40	28	12	25	16	63	12	52	160	2	150	174 391	SNCB-40
50	32	12	27	16	71	12	60	170	2	225	174 392	SNCB-50
63	40	16	32	21	83	16	70	190	2	365	174 393	SNCB-63
80	50	16	36	22	103	16	90	210	2	610	174 394	SNCB-80
100	60	20	41	27	127	20	110	230	2	925	174 395	SNCB-100

1) Corrosion resistance class 2 according to Festo standard 940 070
Components requiring higher corrosion resistance. External visible parts in direct contact with industrial atmospheres or media such as solvents and cleaning agents, with a predominantly functional requirement for the surface

Swivel flange SNCS

Material:
Die-cast aluminium

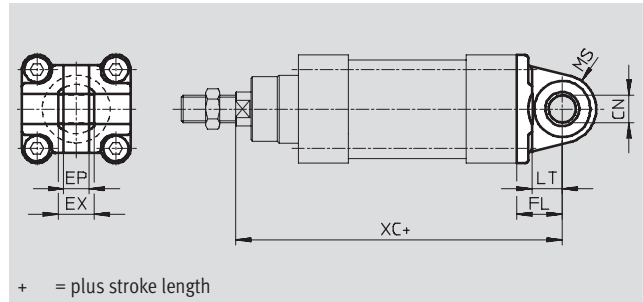
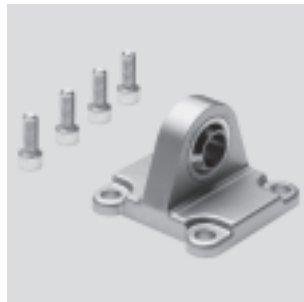

Dimensions and ordering data												
For \varnothing	CN	EP	EX	FL	LT	MS	XC	CRC ¹⁾	Weight	Part No.	Type	
[mm]	\varnothing	-0.2		± 0.2					[g]			
32	10	10.5	14	22	13	15	142	2	85	174 397	SNCS-32	
40	12	12	16	25	16	17	160	2	125	174 398	SNCS-40	
50	16	15	21	27	18	20	170	2	210	174 399	SNCS-50	
63	16	15	21	32	21	22	190	2	280	174 400	SNCS-63	
80	20	18	25	36	22	27	210	2	540	174 401	SNCS-80	
100	20	18	25	41	27	29	230	2	700	174 402	SNCS-100	

1) Corrosion resistance class 2 according to Festo standard 940 070
Components requiring higher corrosion resistance. External visible parts in direct contact with industrial atmospheres or media such as solvents and cleaning agents, with a predominantly functional requirement for the surface

Standard cylinders DNCB, ISO 15552

Accessories



Swivel flange SNCL

Material:
Die-cast aluminium
Free of copper, PTFE and silicone

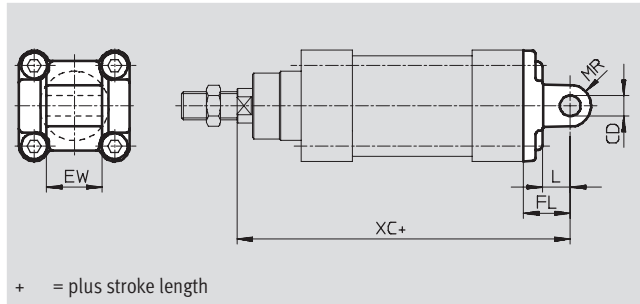
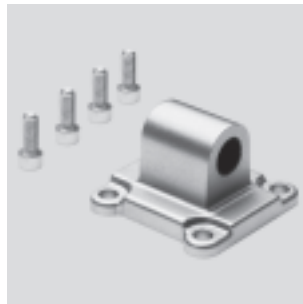

Dimensions and ordering data										
For Ø	CD	EW	FL	L	MR	XC	CRC ¹⁾	Weight	Part No.	Type
[mm]	Ø	h12	±0.2					[g]		
32	10	26	22	13	10	142	2	75	174 404	SNCL-32
40	12	28	25	16	12	160	2	100	174 405	SNCL-40
50	12	32	27	16	12	170	2	160	174 406	SNCL-50
63	16	40	32	21	16	190	2	250	174 407	SNCL-63
80	16	50	36	22	16	210	2	405	174 408	SNCL-80
100	20	60	41	27	20	230	2	655	174 409	SNCL-100





1) Corrosion resistance class 2 according to Festo standard 940 070
Components requiring higher corrosion resistance. External visible parts in direct contact with industrial atmospheres or media such as solvents and cleaning agents, with a predominantly functional requirement for the surface

Ordering data – Mounting attachments				Technical data → 1 / 10.1-2			
Designation	For Ø	Part No.	Type	Designation	For Ø	Part No.	Type
Clevis foot LSNG				Weld-on clevis foot LSNSG			
	32	31 740	LSNG-32		32	31 747	LSNSG-32
	40	31 741	LSNG-40		40	31 748	LSNSG-40
	50	31 742	LSNG-50		50	31 749	LSNSG-50
	63	31 743	LSNG-63		63	31 750	LSNSG-63
	80	31 744	LSNG-80		80	31 751	LSNSG-80
	100	31 745	LSNG-100		100	31 752	LSNSG-100
Clevis foot LBG				Clevis foot LNG			
	32	31 761	LBG-32		32	33 890	LNG-32
	40	31 762	LBG-40		40	33 891	LNG-40
	50	31 763	LBG-50		50	33 892	LNG-50
	63	31 764	LBG-63		63	33 893	LNG-63
	80	31 765	LBG-80		80	33 894	LNG-80
	100	31 766	LBG-100		100	33 895	LNG-100
Clevis foot LSN				Right-angle clevis foot LQG			
	32	5 561	LSN-32		32	31 768	LQG-32
	40	5 562	LSN-40		40	31 769	LQG-40
	50	5 563	LSN-50		50	31 770	LQG-50
	63	5 564	LSN-63		63	31 771	LQG-63
	80	5 565	LSN-80		80	31 772	LQG-80
	100	5 566	LSN-100		100	31 773	LQG-100

Standard cylinders DNCB, ISO 15552

Accessories

FESTO

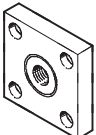
Ordering data – Piston rod attachments				Technical data → 1 / 10.3-2			
Designation	For Ø	Part No.	Type	Designation	For Ø	Part No.	Type
Rod eye SGS				Rod clevis SGA			
	32	9 261	SGS-M10x1,25		32	32 954	SGA-M10x1,25
	40	9 262	SGS-M12x1,25		40	10 767	SGA-M12x1,25
	50	9 263	SGS-M16x1,5		50	10 768	SGA-M16x1,5
	63				63		
	80	9 264	SGS-M20x1,5		80	10 769	SGA-M20x1,5
	100				100		
Rod clevis SG				Self-aligning rod coupler FK			
	32	6 144	SG-M10x1,25		32	6 140	FK-M10x1,25
	40	6 145	SG-M12x1,25		40	6 141	FK-M12x1,25
	50	6 146	SG-M16x1,5		50	6 142	FK-M16x1,5
	63				63		
	80	6 147	SG-M20x1,5		80	6 143	FK-M20x1,5
	100				100		
Coupling piece KSG							
	32	32 963	KSG-M10x1,25				
	40	32 964	KSG-M12x1,25				
	50	32 965	KSG-M16x1,5				
	63						
	80	32 966	KSG-M20x1,5				
	100						

Ordering data – One-way flow control valves				Technical data → Volume 2	
	Connection		Material	Part No.	Type
	For Ø	For tubing OD			
	32	3	Metal design	193 142	GRLA-1/8-QS-3-D
		4		193 143	GRLA-1/8-QS-4-D
		6		193 144	GRLA-1/8-QS-6-D
		8		193 145	GRLA-1/8-QS-8-D
	40, 50	6		193 146	GRLA-1/4-QS-6-D
		8		193 147	GRLA-1/4-QS-8-D
		10		193 148	GRLA-1/4-QS-10-D
		6		193 149	GRLA-3/8-QS-6-D
	63, 80	8		193 150	GRLA-3/8-QS-8-D
		10		193 151	GRLA-3/8-QS-10-D
		6		193 152	GRLA-1/2-QS-12-D
		10			
100	12				

ISO standard cylinders
ISO 15552 (ISO 6431 and VDMA 24562)

1.2

Standard cylinders DNCB, ISO 15552

Accessories



ISO standard cylinders
ISO 15552 (ISO 6431 and VDMA 24562)
1.2

Ordering data – Guide units for fixed strokes (recirculating ball bearing guide only)				Technical data → 1 / 10.4-2		
	Stroke [mm]	Part No.	Type	Stroke [mm]	Part No.	Type
	for Ø 32 mm			for Ø 40 mm		
	10 ... 50	34 493	FENG-32-50-KF	10 ... 50	34 499	FENG-40-50-KF
	10 ... 100	34 494	FENG-32-100-KF	10 ... 100	34 500	FENG-40-100-KF
	10 ... 160	34 495	FENG-32-160-KF	10 ... 160	34 501	FENG-40-160-KF
	10 ... 200	34 496	FENG-32-200-KF	10 ... 200	34 502	FENG-40-200-KF
	10 ... 250	150 289	FENG-32-250-KF	10 ... 250	34 503	FENG-40-250-KF
	10 ... 320	34 497	FENG-32-320-KF	10 ... 320	34 504	FENG-40-320-KF
	10 ... 400	150 290	FENG-32-400-KF	10 ... 400	150 291	FENG-40-400-KF
	10 ... 500	34 498	FENG-32-500-KF	10 ... 500	34 505	FENG-40-500-KF
	for Ø 50 mm			for Ø 63 mm		
	10 ... 50	34 506	FENG-50-50-KF	10 ... 50	34 513	FENG-63-50-KF
	10 ... 100	34 507	FENG-50-100-KF	10 ... 100	34 514	FENG-63-100-KF
	10 ... 160	34 508	FENG-50-160-KF	10 ... 160	34 515	FENG-63-160-KF
	10 ... 200	34 509	FENG-50-200-KF	10 ... 200	34 516	FENG-63-200-KF
	10 ... 250	34 510	FENG-50-250-KF	10 ... 250	34 517	FENG-63-250-KF
	10 ... 320	34 511	FENG-50-320-KF	10 ... 320	34 518	FENG-63-320-KF
	10 ... 400	150 292	FENG-50-400-KF	10 ... 400	34 519	FENG-63-400-KF
	10 ... 500	34 512	FENG-50-500-KF	10 ... 500	34 520	FENG-63-500-KF
	for Ø 80 mm			for Ø 100 mm		
	10 ... 50	34 521	FENG-80-50-KF	10 ... 50	34 529	FENG-100-50-KF
	10 ... 100	34 522	FENG-80-100-KF	10 ... 100	34 530	FENG-100-100-KF
	10 ... 160	34 523	FENG-80-160-KF	10 ... 160	34 531	FENG-100-160-KF
	10 ... 200	34 524	FENG-80-200-KF	10 ... 200	34 532	FENG-100-200-KF
	10 ... 250	34 525	FENG-80-250-KF	10 ... 250	34 533	FENG-100-250-KF
	10 ... 320	34 526	FENG-80-320-KF	10 ... 320	34 534	FENG-100-320-KF
	10 ... 400	34 527	FENG-80-400-KF	10 ... 400	34 535	FENG-100-400-KF
	10 ... 500	34 528	FENG-80-500-KF	10 ... 500	34 536	FENG-100-500-KF



Ordering data – Guide units for variable strokes				Technical data → 1 / 10.4-2		
	For Ø [mm]	Stroke [mm]	With recirculating ball bearing guide		With sliding bearing guide	
			Part No.	Type	Part No.	Type
	32	10 ... 500	34 487	FENG-32-...-KF	34 481	FENG-32-...
	40	10 ... 500	34 488	FENG-40-...-KF	34 482	FENG-40-...
	50	10 ... 500	34 489	FENG-50-...-KF	34 483	FENG-50-...
	63	10 ... 500	34 490	FENG-63-...-KF	34 484	FENG-63-...
	80	10 ... 500	34 491	FENG-80-...-KF	34 485	FENG-80-...
	100	10 ... 500	34 492	FENG-100-...-KF	34 486	FENG-100-...

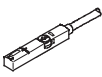
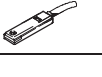
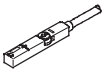

Standard cylinders DNCB, ISO 15552

Accessories

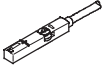
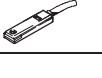
FESTO

Ordering data – Proximity switches for T-slot, magneto-resistive					Technical data → www.festo.com/catalogue/sm	
	Type of mounting	Switch output	Electrical connection	Cable length [m]	Part No.	Type
N/O contact						
	Insertable in the slot from above, flush with cylinder profile	PNP	Cable, 3-wire	2,5	543 867	SMT-8M-PS-24V-K-2,5-OE
			Plug M8x1, 3-pin	0,3	543 866	SMT-8M-PS-24V-K-0,3-M8D
			Plug M12x1, 3-pin	0,3	543 869	SMT-8M-PS-24V-K-0,3-M12
		NPN	Cable, 3-wire	2,5	543 870	SMT-8M-NS-24V-K-2,5-OE
Plug M8x1, 3-pin	0,3		543 871	SMT-8M-NS-24V-K-0,3-M8D		
	Insertable in the slot lengthwise, flush with the cylinder profile	PNP	Cable, 3-wire	2,5	175 436	SMT-8-PS-K-LED-24-B
			Plug M8x1, 3-pin	0,3	175 484	SMT-8-PS-S-LED-24-B
N/C contact						
	Insertable in the slot from above, flush with cylinder profile	PNP	Cable, 3-wire	7,5	543 873	SMT-8M-PO-24V-K7,5-OE

Ordering data – Proximity switches for T-slot, magnetic reed					Technical data → www.festo.com/catalogue/sm		
	Type of mounting	Switch output	Electrical connection	Cable length [m]	Part No.	Type	
N/O contact							
	Insertable in the slot from above, flush with cylinder profile	Contacting	Cable, 3-wire	2,5	543 862	SME-8M-DS-24V-K-2,5-OE	
				5,0	543 863	SME-8M-DS-24V-K-5,0-OE	
			Plug M8x1, 3-pin	Cable, 3-wire	2,5	543 872	SME-8M-ZS-24V-K-2,5-OE
				0,3	543 861	SME-8M-DS-24V-K-0,3-M8D	
	Insertable in the slot lengthwise, flush with the cylinder profile	Contacting	Cable, 3-wire	2,5	150 855	SME-8-K-LED-24	
				0,3	150 857	SME-8-S-LED-24	
N/C contact							
	Insertable in the slot lengthwise, flush with the cylinder profile	Contacting	Cable, 3-wire	7,5	160 251	SME-8-0-K-LED-24	

Ordering data – Connecting cables				Technical data → www.festo.com/catalogue/nebu	
	Electrical connection, left	Electrical connection, right	Cable length [m]	Part No.	Type
	Straight socket, M8x1, 3-pin	Cable, open end, 3-wire	2,5	541 333	NEBU-M8G3-K-2.5-LE3
			5	541 334	NEBU-M8G3-K-5-LE3
	Straight socket, M12x1, 5-pin	Cable, open end, 3-wire	2,5	541 363	NEBU-M12G5-K-2.5-LE3
			5	541 364	NEBU-M12G5-K-5-LE3
	Angled socket, M8x1, 3-pin	Cable, open end, 3-wire	2,5	541 338	NEBU-M8W3-K-2.5-LE3
			5	541 341	NEBU-M8W3-K-5-LE3
Angled socket, M12x1, 5-pin	Cable, open end, 3-wire	2,5	541 367	NEBU-M12W5-K-2.5-LE3	
		5	541 370	NEBU-M12W5-K-5-LE3	

Ordering data – Slot cover for T-slot			Part No.	Type
	Mounting	Length [m]		
	Insertable from above	2x 0.5	151 680	ABP-5-S

ISO standard cylinders
ISO 15552 (ISO 6431 and VDMA 24562)

1.2

