



- Modular
- Simple and time-saving project engineering
- Fast system assembly

Multi-axis modular system

Key features



The concept





The multi-axis modular system for handling and assembly technology includes basic, connection and installation components for assembling multi-axis systems. These standardised axis combinations are the product of over ten years experience in the designing

of handling systems. The concept of the multi-axis modular system is based on a modular design with axis modules along the X-, Y- and Z-axes. These modules all have the same interfaces, which means they can be combined together.

Standard solutions with specifications on stroke, working load and intermediate positions offer practical module combinations. The advantages of this modularity are as follows:

- Simple and time-saving project engineering
- Fast system assembly
- Availability of CAD data for standard designs

Selection matrix

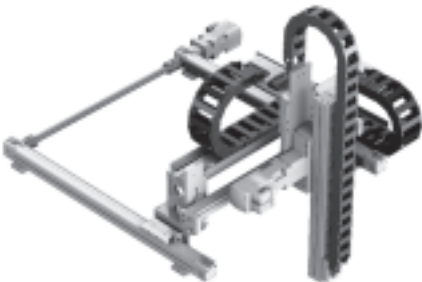
Pick & place	Linear gantries	3-Dimensional gantries
Pneumatic		Pneumatic/electrical
 <p>→ 5 / 3.3-36</p>	 <p>→ 5 / 3.3-54</p>	 <p>→ 5 / 3.3-68</p>
Pneumatic with end position controller SPC11 (Soft Stop)		
	 <p>→ 5 / 3.3-54</p>	
Electrical with spindle or toothed belt axis		
	 <p>→ 5 / 3.3-54</p>	 <p>→ 5 / 3.3-68</p>

Multi-axis modular system

Key features

FESTO

Pick & place

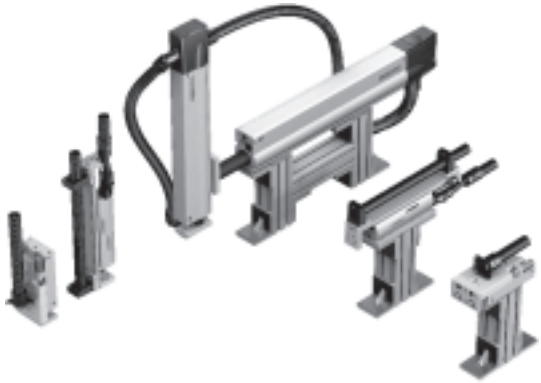

Linear gantries



3-Dimensional gantries



System components
Multi-axis modular system

3.3

Pick & place

Key features



Y and Z modules

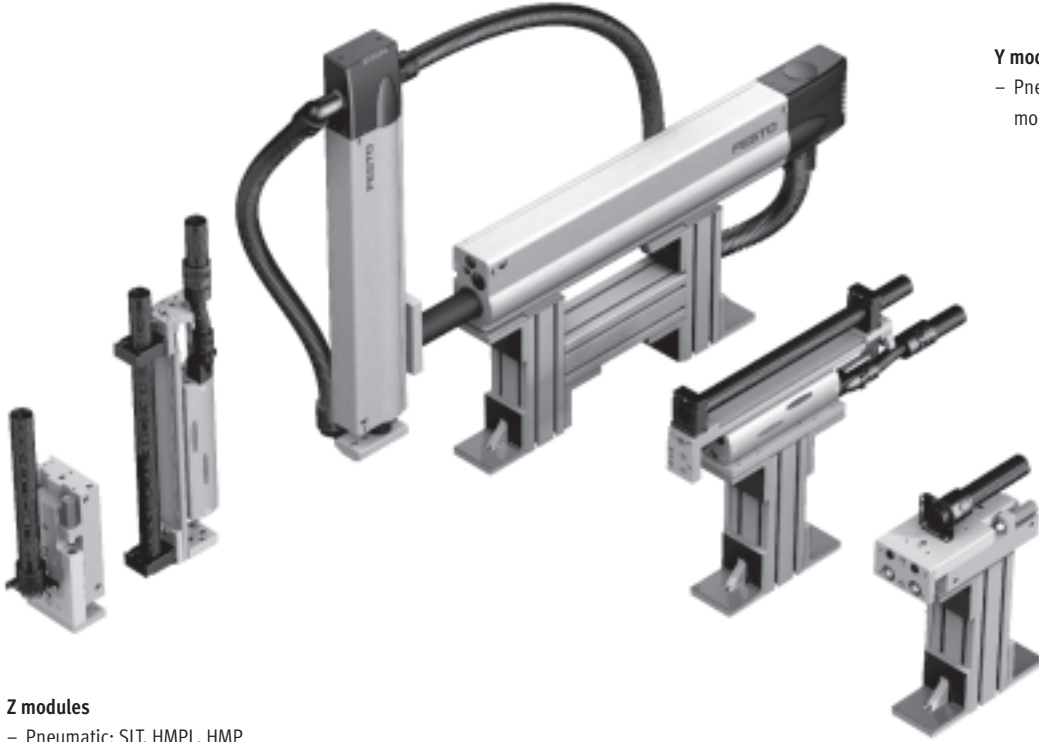

Y modules

- Pneumatic: SLT, HMPL, HMP mounted on basic components

Z modules





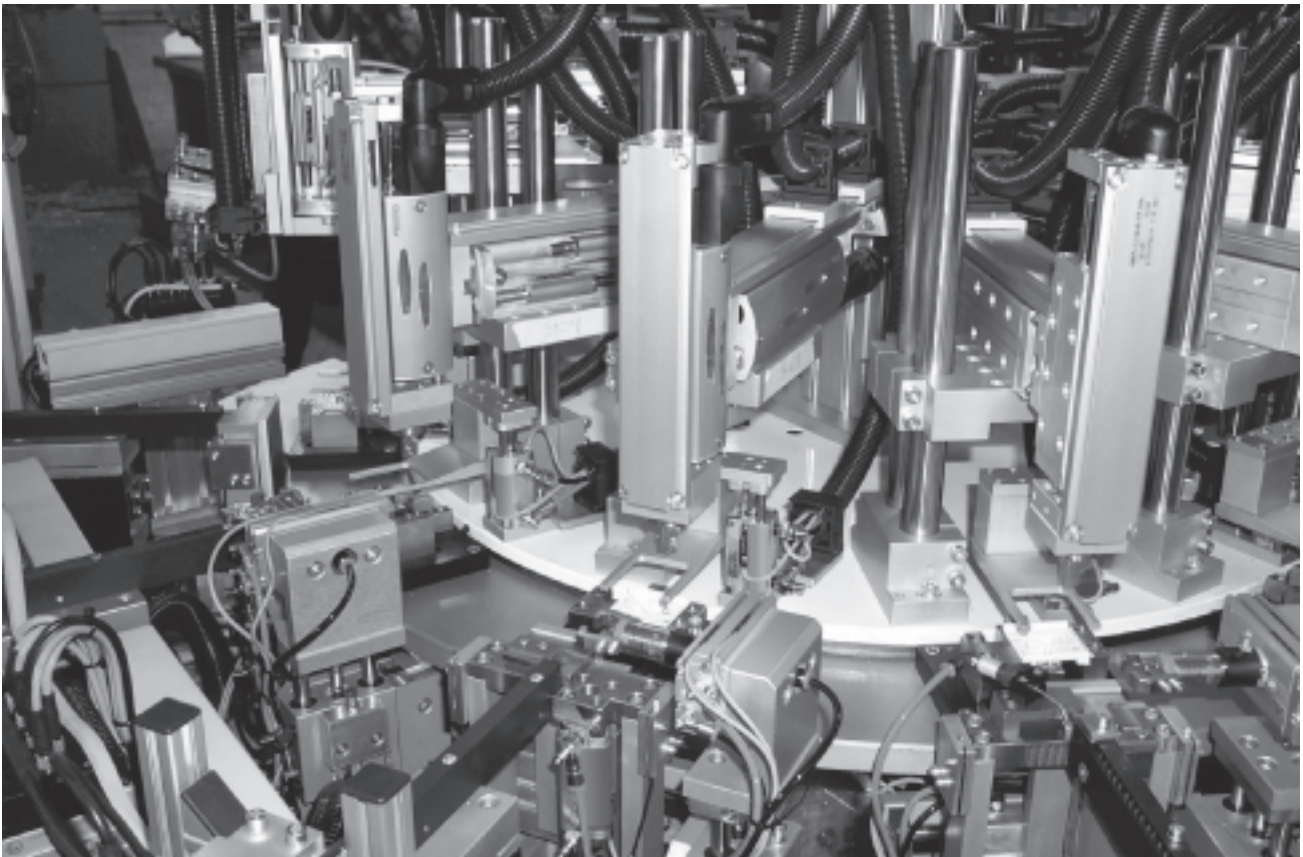

- Pneumatic: SLT, HMPL, HMP

Application

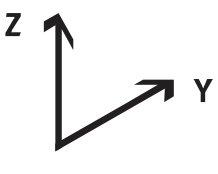

Pick & place



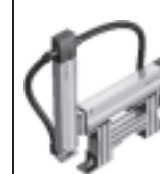

Product range overview

Selection aid						
Function	DGSL/DGSL	SLT/SLT	HMPL/HMPL	HM.../DGSL, SLT	HMP.../HMPL	HM.../HMP
						
Y-axis	DGSL	SLT	HMPL	HMP, HME	HMP, HME	HMP, HME
Drive function	Pneumatic					
Options	Shock absorber, adjustable/non-adjustable cushioning	Shock absorber, adjustable/non-adjustable cushioning	Intermediate position, clamping cartridge	Intermediate position		
Z-axis	DGSL	SLT	HMPL	DGSL, SLT	HMPL	HMP
Drive function	Pneumatic					
Options	Shock absorber, adjustable/non-adjustable cushioning	Shock absorber, adjustable/non-adjustable cushioning	Intermediate position, clamping cartridge	Shock absorber, adjustable/non-adjustable cushioning	Intermediate position, clamping cartridge	
Working load [kg]						
	1	■	■	■	■	■
	2	■	■	■	■	■
	3	■	■	■	■	■
	4	-	-	-	■	■
	6	-	-	-	■	■
	10	-	-	-	-	■
→ Page	5 / 3.3-38					

Pick & place





Selection aid for basic, connection and installation components

FESTO

Y-axis				
Function	DGSL/DGSL		SLT/SLT	HMPL/HMPL
				
Pneumatic drives	Stroke [mm]	Type		
DGSL-16	30 ... 150	HMBSY-DGSL-1 → 5 / 3.3-42	–	–
DGSL-20	30 ... 100	HMBSY-DGSL-2 → 5 / 3.3-42	–	–
	125 ... 200	HMBSY-DGSL-3 → 5 / 3.3-42	–	–
DGSL-25	30 ... 100	HMBSY-DGSL-4 → 5 / 3.3-42	–	–
	125 ... 200	HMBSY-DGSL-5 → 5 / 3.3-42	–	–
SLT-16	30 ... 150	–	HMBSY-SLT-1 → 5 / 3.3-43	–
SLT-20	30 ... 100	–	HMBSY-SLT-2 → 5 / 3.3-43	–
	125 ... 200	–	HMBSY-SLT-3 → 5 / 3.3-43	–
SLT-25	30 ... 100	–	HMBSY-SLT-4 → 5 / 3.3-43	–
	125 ... 200	–	HMBSY-SLT-5 → 5 / 3.3-43	–
HMPL-16	50 ... 160	–	–	HMBSY-HMPL-1 HMBSY-HMPL-2 → 5 / 3.3-44
HMPL-20	50 ... 200	–	–	HMBSY-HMPL-3 HMBSY-HMPL-4 → 5 / 3.3-44

Pick & place

Selection aid for basic, connection and installation components

Y-axis		Function		
Function		HMP, HME/DGSL, SLT	HMP, HME/HMPL	HMP, HME/HMP
				
Pneumatic drives	Stroke [mm]	Type		
HMP-16	150 ... 250	HMBSY-HMP-1 → 5 / 3.3-45	HMBSY-HMP-1 → 5 / 3.3-45	–
	320	HMBSY-HMP-2 → 5 / 3.3-45	HMBSY-HMP-2 → 5 / 3.3-45	–
HMP-20	100 ... 250	HMBSY-HMP-3 → 5 / 3.3-45	HMBSY-HMP-3 → 5 / 3.3-45	HMBSY-HMP-3 → 5 / 3.3-45
	320 ... 400	HMBSY-HMP-4 → 5 / 3.3-45	HMBSY-HMP-4 → 5 / 3.3-45	HMBSY-HMP-4 → 5 / 3.3-45
HMP-25	100 ... 200	HMBSY-HMP-5 → 5 / 3.3-46	–	HMBSY-HMP-5 → 5 / 3.3-46
	250 ... 400	HMBSY-HMP-6 → 5 / 3.3-46	–	HMBSY-HMP-6 → 5 / 3.3-46
HMP-32	100 ... 200	–	–	HMBSY-HMP-7 → 5 / 3.3-46
	250 ... 400	–	–	HMBSY-HMP-8 → 5 / 3.3-46

Selection example

Project engineering produced the following drive combination:

Y-axis: HMP-16,
200 mm stroke
Z-axis: HMPL-16,
with intermediate position

Step 1

Define the drive type in the selection aids for the Y- or Z-axis. The associated bill of materials can be found on the specified page.

Y-axis: HMBSY-HMP-1
→ 5 / 3.3-45
Z-axis: HMBSZ-HMPL-3 or 4
→ 5 / 3.3-51

Step 2

The necessary basic, connection and installation components can be found in the bill of materials on the specified page.

Y-axis: HMBSY-HMP-1
Z-axis: HMBSZ-HMPL-4

Step 3

Technical data on the basic, connection and installation components can be found on the specified pages. Further accessories for the selected drives, for example proximity sensors, centring sleeves, etc. are documented with the drives.

Pick & place





Selection aid for basic, connection and installation components



Z-axis				
Function	DGSL/DGSL	SLT/SLT	HMPL/HMPL	HMP, HME/DGSL
Pneumatic drives	Type			
DGSL-10	HMBSZ-DGSL-1 → 5 / 3.3-47	-	-	-
DGSL-16	HMBSZ-DGSL-2 → 5 / 3.3-47	-	-	HMBSZ-DGSL-4 → 5 / 3.3-48
DGSL-20	HMBSZ-DGSL-3 → 5 / 3.3-47	-	-	HMBSZ-DGSL-5 → 5 / 3.3-48
DGSL-25	-	-	-	HMBSZ-DGSL-6 → 5 / 3.3-48
SLT-10	-	HMBSZ-SLT-1 → 5 / 3.3-49	-	-
SLT-16	-	HMBSZ-SLT-2 → 5 / 3.3-49	-	-
SLT-20	-	HMBSZ-SLT-3 → 5 / 3.3-49	-	-
SLT-25	-	-	-	-
HMPL-12	-	-	HMBSZ-HMPL-1 HMBSZ-HMPL-2	-
HMPL-16	-	-	→ 5 / 3.3-51	-
HMPL-20	-	-	-	-
HMP-16	-	-	-	-
HMP-20	-	-	-	-
HMP-25	-	-	-	-

Pick & place

Selection aid for basic, connection and installation components

Z-axis			
Function	HMP, HME/SLT	HMP, HME/HMPL	HMP, HME/HMP
			
Pneumatic drives	Type		
SLT-16	HMBSZ-SLT-4 → 5 / 3.3-50	–	–
SLT-20	HMBSZ-SLT-5 → 5 / 3.3-50	–	–
SLT-25	HMBSZ-SLT-6 → 5 / 3.3-50	–	–
HMPL-16	–	HMBSZ-HMPL-3 HMBSZ-HMPL-4 → 5 / 3.3-51	–
HMPL-20	–	–	–
HMP-16	–	–	HMBSZ-HMP-1 → 5 / 3.3-52
HMP-20	–	–	HMBSZ-HMP-2 → 5 / 3.3-52
HMP-25	–	–	HMBSZ-HMP-3 → 5 / 3.3-52

Selection example

Project engineering produced the following drive combination:

Y-axis: HMP-16,
200 mm stroke
Z-axis: HMPL-16,
with intermediate position

Step 1

Define the drive type in the selection aids for the Y- or Z-axis. The associated bill of materials can be found on the specified page.

Y-axis: HMBSY-HMP-1
→ 5 / 3.3-45
Z-axis: HMBSZ-HMPL-3 or 4
→ 5 / 3.3-51

Step 2

The necessary basic, connection and installation components can be found in the bill of materials on the specified page.

Y-axis: HMBSY-HMP-1
Z-axis: HMBSZ-HMPL-4

Step 3

Technical data on the basic, connection and installation components can be found on the specified pages. Further accessories for the selected drives, for example proximity sensors, centring sleeves, etc. are documented with the drives.

Pick & place

Y modules



Mini slides DGSL

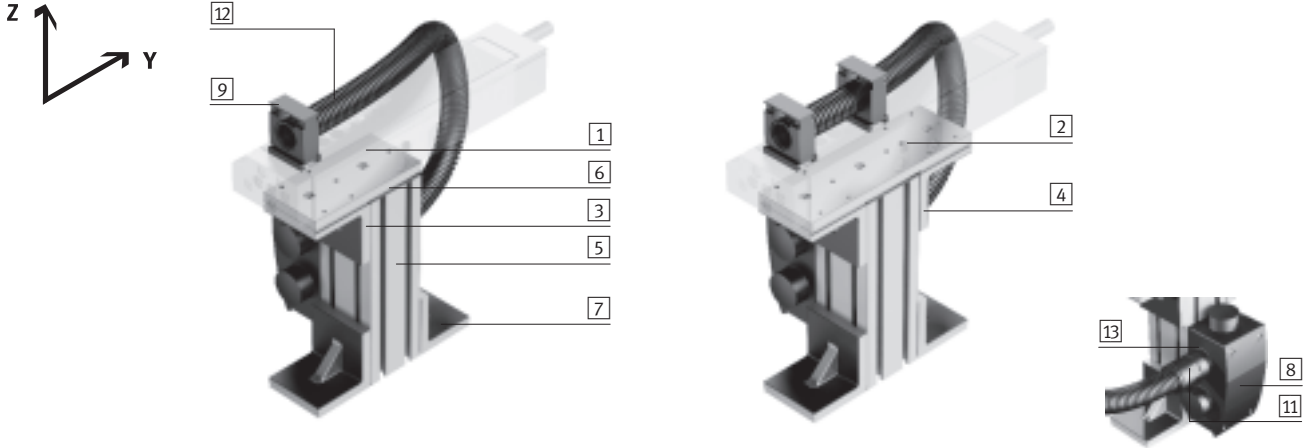

Bill of materials												
Type		HMBSY-DGSL-1	HMBSY-DGSL-2	HMBSY-DGSL-3	HMBSY-DGSL-4	HMBSY-DGSL-5						
For drives		DGSL-16	DGSL-20	125 ... 200		DGSL-25						
Stroke [mm]		30 ... 150	30 ... 100	125 ... 200		30 ... 100	125 ... 200					
Item	Quantity	Part No.	Type	Part No.	Type	Part No.	Type	Part No.	Type	Part No.	Type	→ Page
[1]	1	539 968 HMVY-1		539 969 HMVY-2		–		539 969 HMVY-2		–		90
[2]	1	–		–		539 970 HMVY-3		–		539 970 HMVY-3		
[3]	1	175 967 HMBV-ND		175 967 HMBV-ND		–		175 967 HMBV-ND		–		5 / 3.3-108
[4]	2	–		–		175 967 HMBV-ND		–		175 967 HMBV-ND		
[5]	1 ¹⁾	175 958 HMBS-80/80		175 958 HMBS-80/80		175 958 HMBS-80/80		175 958 HMBS-80/80		175 958 HMBS-80/80		5 / 3.3-105
[6]	1	175 965 HMBSA-80/80		175 965 HMBSA-80/80		175 965 HMBSA-80/80		175 965 HMBSA-80/80		175 965 HMBSA-80/80		5 / 3.3-105
[7]	2	175 951 HMBF-DB		175 951 HMBF-DB		175 951 HMBF-DB		175 951 HMBF-DB		175 951 HMBF-DB		5 / 3.3-107
[8]	1	175 126 HMZV		175 126 HMZV		175 126 HMZV		175 126 HMZV		175 126 HMZV		5 / 3.3-125
[9]	1	192 289 MKRS-16,5-B 548 803 ZBV-M5-7		192 290 MKRS-23-B 548 804 ZBV-M5-9		192 290 MKRS-23-B 548 804 ZBV-M5-9		192 290 MKRS-23-B 548 804 ZBV-M5-9		192 290 MKRS-23-B 548 804 ZBV-M5-9		5 / 3.3-131
[11]	1	177 571 MKRV-16,5-PG-16		177 572 MKRV-23-PG-21		177 572 MKRV-23-PG-21		177 572 MKRV-23-PG-21		177 572 MKRV-23-PG-21		5 / 3.3-126
[12]	1 ²⁾	177 566 MKR-16,5-PG-16		177 567 MKR-23-PG-21		177 567 MKR-23-PG-21		177 567 MKR-23-PG-21		177 567 MKR-23-PG-21		5 / 3.3-124
[13]	1	193 949 MKA-PG-29-PG-16-KU		177 595 MKA-PG-29-PG-21		177 595 MKA-PG-29-PG-21		177 595 MKA-PG-29-PG-21		177 595 MKA-PG-29-PG-21		5 / 3.3-129

1) Height max. 500 mm

2) Length depends on the stroke of the drive

Pick & place

Y modules

Mini slides SLT

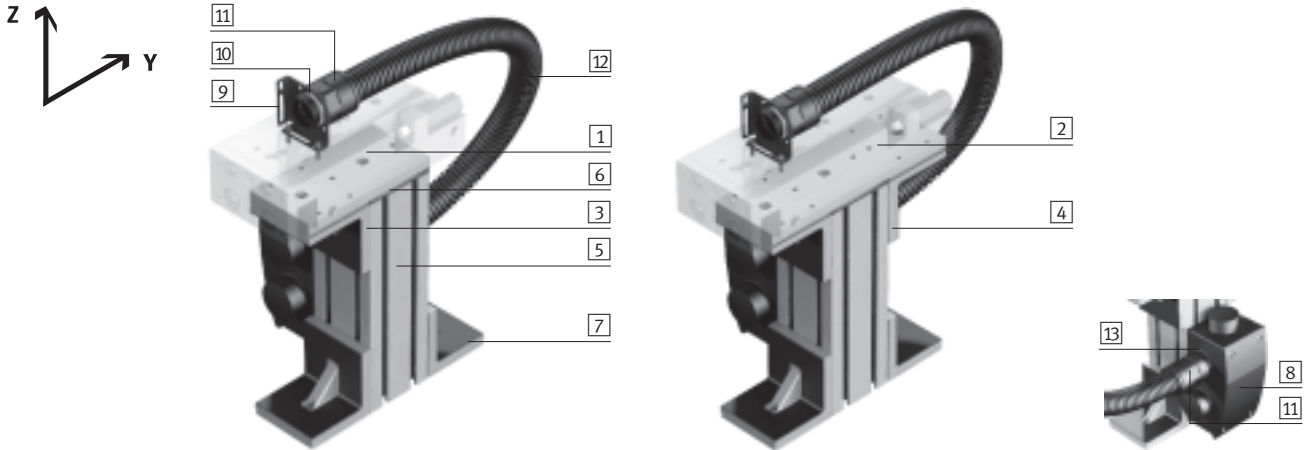

Bill of materials												
Type	HMBSY-SLT-1		HMBSY-SLT-2		HMBSY-SLT-3		HMBSY-SLT-4		HMBSY-SLT-5		→ Page	
For drives	SLT-16		SLT-20		SLT-25		SLT-25					
Stroke [mm]	30 ... 150		30 ... 100		125 ... 200		30 ... 100		125 ... 200			
Item	Quantity	Part No.	Type	Part No.	Type	Part No.	Type	Part No.	Type	Part No.	Type	
1	1	539 968	HMVY-1	539 969	HMVY-2	-		539 969	HMVY-2	-		90
2	1	-		-		539 970	HMVY-3	-		539 970	HMVY-3	
3	1	175 967	HMBV-ND	175 967	HMBV-ND	-		175 967	HMBV-ND	-		5 / 3.3-108
4	2	-		-		175 967	HMBV-ND	-		175 967	HMBV-ND	
5	1 ¹⁾	175 958	HMBS-80/80	175 958	HMBS-80/80	175 958	HMBS-80/80	175 958	HMBS-80/80	175 958	HMBS-80/80	5 / 3.3-105
6	1	175 965	HMBSA-80/80	175 965	HMBSA-80/80	175 965	HMBSA-80/80	175 965	HMBSA-80/80	175 965	HMBSA-80/80	5 / 3.3-105
7	2	175 951	HMBF-DB	175 951	HMBF-DB	175 951	HMBF-DB	175 951	HMBF-DB	175 951	HMBF-DB	5 / 3.3-107
8	1	175 126	HMZV	175 126	HMZV	175 126	HMZV	175 126	HMZV	175 126	HMZV	5 / 3.3-125
9	1	193 124	HMZAS-PG-21	193 124	HMZAS-PG-21	193 124	HMZAS-PG-21	193 124	HMZAS-PG-21	193 124	HMZAS-PG-21	5 / 3.3-132
10	1	177 599	MKM-PG-21	177 599	MKM-PG-21	177 599	MKM-PG-21	177 599	MKM-PG-21	177 599	MKM-PG-21	5 / 3.3-131
11	2	177 572	MKRV-23-PG-21	177 572	MKRV-23-PG-21	177 572	MKRV-23-PG-21	177 572	MKRV-23-PG-21	177 572	MKRV-23-PG-21	5 / 3.3-126
12	1 ²⁾	177 567	MKR-23-PG-21	177 567	MKR-23-PG-21	177 567	MKR-23-PG-21	177 567	MKR-23-PG-21	177 567	MKR-23-PG-21	5 / 3.3-124
13	1	177 595	MKA-PG-29-PG-21	177 595	MKA-PG-29-PG-21	177 595	MKA-PG-29-PG-21	177 595	MKA-PG-29-PG-21	177 595	MKA-PG-29-PG-21	5 / 3.3-129

1) Height max. 500 mm
 2) Length depends on the stroke of the drive

Pick & place

Y modules



Linear modules HMPL

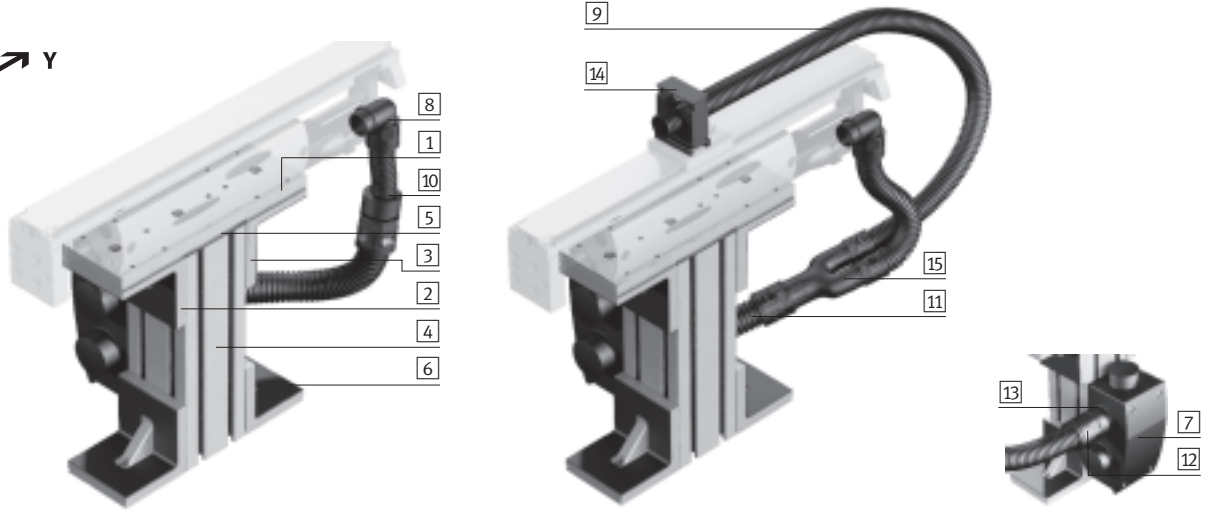

Bill of materials										
Type		HMBSY-HMPL-1	HMBSY-HMPL-2	HMBSY-HMPL-3	HMBSY-HMPL-4					
For drives		HMPL-16		HMPL-20						
		without intermediate position	with intermediate position	without intermediate position	with intermediate position					
Item	Quantity	Part No.	Type	Part No.	Type	Part No.	Type	Part No.	Type	→ Page
[1]	1	539 968	HMVY-1	539 968	HMVY-1	539 970	HMVY-3	539 970	HMVY-3	90
[2]	1	175 967	HMBV-ND	175 967	HMBV-ND	-	-	-	-	5 / 3.3-108
[3]	2	-	-	-	-	175 967	HMBV-ND	175 967	HMBV-ND	
[4]	1 ¹⁾	175 958	HMBS-80/80	175 958	HMBS-80/80	175 958	HMBS-80/80	175 958	HMBS-80/80	5 / 3.3-105
[5]	1	175 965	HMBSA-80/80	175 965	HMBSA-80/80	175 965	HMBSA-80/80	175 965	HMBSA-80/80	5 / 3.3-105
[6]	2	175 951	HMBF-DB	175 951	HMBF-DB	175 951	HMBF-DB	175 951	HMBF-DB	5 / 3.3-107
[7]	1	175 126	HMZV	175 126	HMZV	175 126	HMZV	175 126	HMZV	5 / 3.3-125
[8]	1	177 576	MKRL-16,5-PG-16	177 576	MKRL-16,5-PG-16	177 576	MKRL-16,5-PG-16	177 576	MKRL-16,5-PG-16	5 / 3.3-126
[9]	1 ²⁾	177 566	MKR-16,5-PG-16	177 566	MKR-16,5-PG-16	177 566	MKR-16,5-PG-16	177 566	MKR-16,5-PG-16	5 / 3.3-124
[10]	1	194 321	MKRT-23-16,5	-	-	194 321	MKRT-23-16,5	-	-	5 / 3.3-128
[11]	1 ²⁾	177 567	MKR-23-PG-21	177 567	MKR-23-PG-21	177 567	MKR-23-PG-21	177 567	MKR-23-PG-21	5 / 3.3-124
[12]	1	177 572	MKRV-23-PG-21	177 572	MKRV-23-PG-21	177 572	MKRV-23-PG-21	177 572	MKRV-23-PG-21	5 / 3.3-126
[13]	1	177 595	MKA-PG-29-PG-21	177 595	MKA-PG-29-PG-21	177 595	MKA-PG-29-PG-21	177 595	MKA-PG-29-PG-21	5 / 3.3-129
[14]	1 ³⁾	-	-	192 289	MKRS-16,5-B	-	-	192 289	MKRS-16,5-B	5 / 3.3-131
[15]	1	-	-	193 946	MKY-PG-21-2PG-16	-	-	193 946	MKY-PG-21-2PG-16	5 / 3.3-128

1) Height max. 500 mm

2) Length depends on the stroke of the drive, 2 conduits are required with an intermediate position.

3) In order to be able to mount the retaining clip MKRS, a clamping component (1x code J) must be selected as an accessory in the order for the linear module HMPL.

Pick & place

Y modules

Linear modules HMP, HME

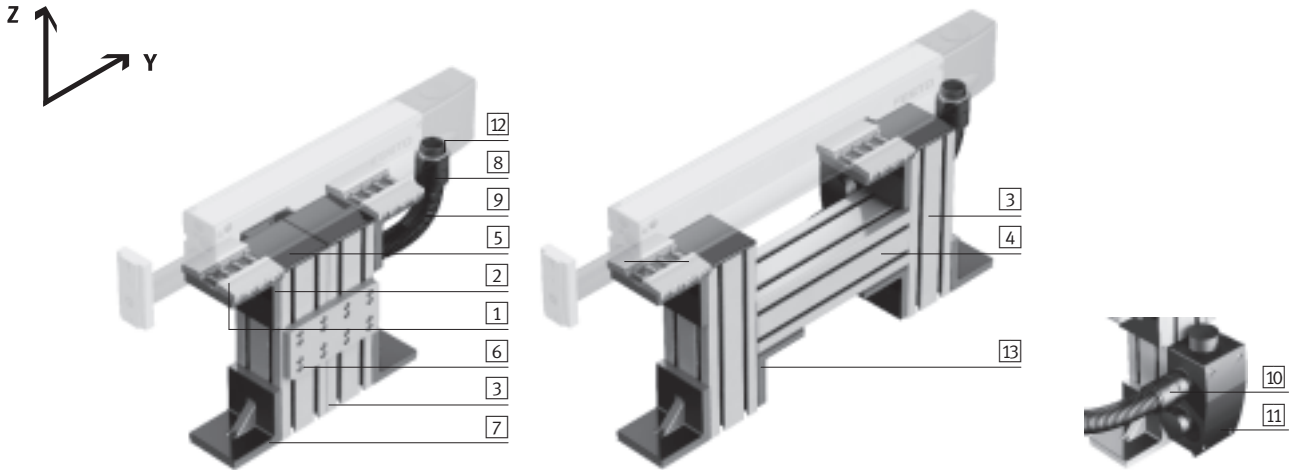

Bill of materials								→ Page
Type	HMBSY-HMP-1		HMBSY-HMP-2		HMBSY-HMP-3		HMBSY-HMP-4	
For drives	HMP-/HME-16				HMP-20			
Stroke [mm]	150 ... 250		320		100 ... 250		320 ... 400	
Item	Quantity	Part No.	Type	Part No.	Type	Part No.	Type	
1	2	175 975	HMBK-WS	175 975	HMBK-WS	175 975	HMBK-WS	89
2	2	175 967	HMBV-ND	175 967	HMBV-ND	175 967	HMBV-ND	5 / 3.3-108
3	2 ¹⁾	175 958	HMBS-80/80	175 958	HMBS-80/80	175 958	HMBS-80/80	5 / 3.3-105
4	1 ²⁾	-		175 958	HMBS-80/80	-	175 958 HMBS-80/80	
5	2	175 965	HMBSA-80/80	175 965	HMBSA-80/80	175 965	HMBSA-80/80	5 / 3.3-105
6	1	175 972	HMBSV	-		175 972	HMBSV	5 / 3.3-106
7	2	175 951	HMBF-DB	175 951	HMBF-DB	175 951	HMBF-DB	5 / 3.3-107
8	2 ⁴⁾	177 572	MKRV-23-PG-21	177 572	MKRV-23-PG-21	177 573	MKRV-29-PG-29	5 / 3.3-126
9	1 ³⁾⁴⁾	177 567	MKR-23-PG-21	177 567	MKR-23-PG-21	177 568	MKR-29-PG-29	5 / 3.3-124
10	1 ⁴⁾	177 595	MKA-PG-29-PG-21	177 595	MKA-PG-29-PG-21	-	-	5 / 3.3-129
11	1 ⁴⁾	175 126	HMZV	175 126	HMZV	175 126	HMZV	5 / 3.3-125
12	1 ⁴⁾	177 599	MKM-PG-21	177 599	MKM-PG-21	177 600	MKM-PG-29	5 / 3.3-131
13	2	-		178 228	HMBSW	-	178 228 HMBSW	5 / 3.3-106

- 1) Height max. 500 mm
- 2) Length 250 mm
- 3) Length depends on the stroke of the drive
- 4) It is not suitable for use with linear module HME

Pick & place

Y modules



Linear modules HMP, HME

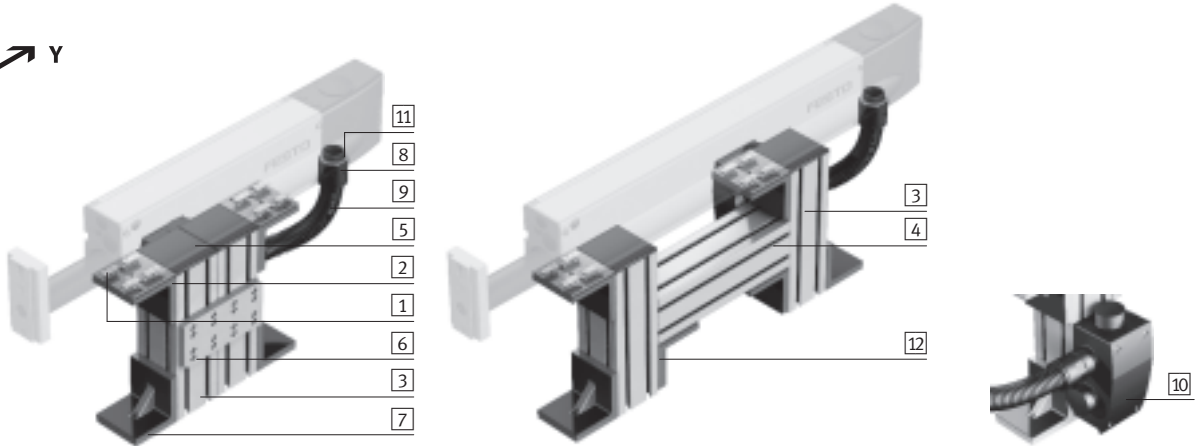

Bill of materials										
Type	HMBSY-HMP-5		HMBSY-HMP-6		HMBSY-HMP-7		HMBSY-HMP-8		→ Page	
For drives	HMP-/HME-25				HMP-32					
Stroke [mm]	100 ... 200		250 ... 400		100 ... 200		250 ... 400			
Item	Quantity	Part No.	Type	Part No.	Type	Part No.	Type	Part No.		Type
[1]	2	175 970	HMBK-ND	175 970	HMBK-ND	175 970	HMBK-ND	175 970	HMBK-ND	88
[2]	2	175 967	HMBV-ND	175 967	HMBV-ND	175 967	HMBV-ND	175 967	HMBV-ND	5 / 3.3-108
[3]	2 ¹⁾	175 958	HMBS-80/80	175 958	HMBS-80/80	175 958	HMBS-80/80	175 958	HMBS-80/80	5 / 3.3-105
[4]	1 ²⁾	-		175 958	HMBS-80/80	-		175 958	HMBS-80/80	
[5]	2	175 965	HMBSA-80/80	175 965	HMBSA-80/80	175 965	HMBSA-80/80	175 965	HMBSA-80/80	5 / 3.3-105
[6]	1	175 972	HMBSV	-		175 972	HMBSV	-		5 / 3.3-106
[7]	2	175 951	HMBF-DB	175 951	HMBF-DB	175 951	HMBF-DB	175 951	HMBF-DB	5 / 3.3-107
[8]	2 ⁴⁾	177 573	MKRV-29-PG-29	177 573	MKRV-29-PG-29	177 573	MKRV-29-PG-29	177 573	MKRV-29-PG-29	5 / 3.3-126
[9]	1 ³⁾⁴⁾	177 568	MKR-29-PG-29	177 568	MKR-29-PG-29	177 568	MKR-29-PG-29	177 568	MKR-29-PG-29	5 / 3.3-124
[10]	1 ⁴⁾	175 126	HMZV	175 126	HMZV	175 126	HMZV	175 126	HMZV	5 / 3.3-125
[11]	1 ⁴⁾	177 600	MKM-PG-29	177 600	MKM-PG-29	177 600	MKM-PG-29	177 600	MKM-PG-29	5 / 3.3-131
[12]	2	-		178 228	HMBSW	-		178 228	HMBSW	5 / 3.3-106

- 1) Height max. 500 mm
- 2) Length 350 mm
- 3) Length depends on the stroke of the drive
- 4) It is not suitable for use with linear module HME

Pick & place

Z modules

Mini slides DGSL

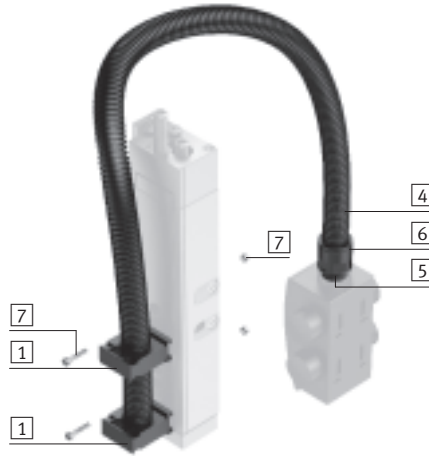

Bill of materials						
Type		HMBSZ-DGSL-1		HMBSZ-DGSL-2		HMBSZ-DGSL-3
For drives		DGSL-10		DGSL-16		DGSL-20
Item	Quantity	Part No.	Type	Part No.	Type	Part No. Type
→ Page						
1	2	192 289	MKRS-16,5-B M4x12 DIN 912	192 289	MKRS-16,5-B 548 803 ZBV-M5-7	192 290 MKRS-23-B 548 804 ZBV-M5-9
4	1 ¹⁾	177 566	MKR-16,5-PG-16	177 566	MKR-16,5-PG-16	177 567 MKR-23-PG-21
5	1	193 949	MKA-PG-29-PG-16-KU	193 949	MKA-PG-29-PG-16-KU	177 595 MKA-PG-29-PG-21
6	1	177 571	MKRV-16,5-PG-16	177 571	MKRV-16,5-PG-16	177 572 MKRV-23-PG-21
7	1	548 803	ZBV-M5-7	548 804	ZBV-M5-9	150 927 ZBH-9 ²⁾

1) Length depends on the stroke of the drive

2) Centring sleeves are included in the scope of delivery of the mini slide DGSL.

Pick & place

Z modules

Mini slides DGSL

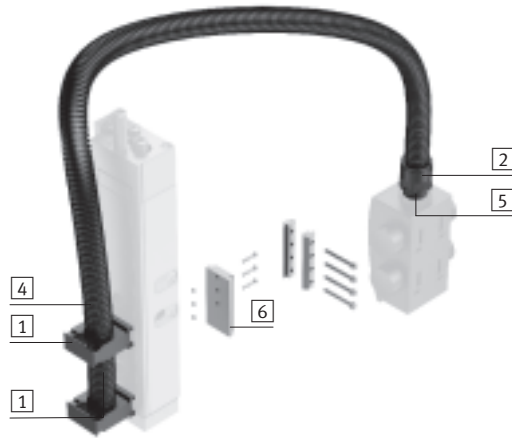

Bill of materials								
Type		HMBSZ-DGSL-4		HMBSZ-DGSL-5		HMBSZ-DGSL-6		
For drives		DGSL-16		DGSL-20		DGSL-25		
Item	Quantity	Part No.	Type	Part No.	Type	Part No.	Type	→ Page
[1]	2	192 289	MKRS-16,5-B	192 290	MKRS-23-B	192 290	MKRS-23-B	5 / 3.3-131
		548 803	ZBV-M5-7	548 804	ZBV-M5-9	548 804	ZBV-M5-9	
[2]	1	177 571	MKRV-16,5-PG-16	177 572	MKRV-23-PG-21	177 572	MKRV-23-PG-21	5 / 3.3-126
[4]	1 ¹⁾	177 566	MKR-16,5-PG-16	177 567	MKR-23-PG-21	177 567	MKR-23-PG-21	5 / 3.3-124
[5]	1	193 949	MKA-PG-29-PG-16-KU	177 595	MKA-PG-29-PG-21	177 595	MKA-PG-29-PG-21	5 / 3.3-129
[6]	1	548 779	HMSV-49	548 779	HMSV-49	548 779	HMSV-49	5 / 3.2-10

1) Length depends on the stroke of the drive

Pick & place

Z modules

Mini slides SLT

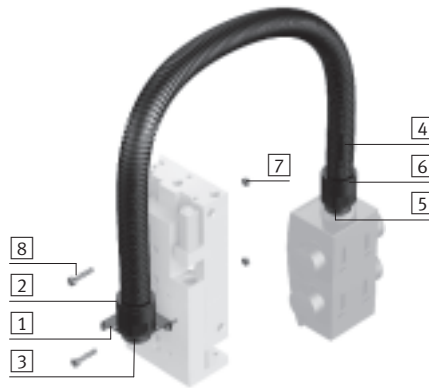

Bill of materials								
Type		HMBSZ-SLT-1		HMBSZ-SLT-2		HMBSZ-SLT-3		
For drives		SLT-10		SLT-16		SLT-20		
Item	Quantity	Part No.	Type	Part No.	Type	Part No.	Type	
							→ Page	
1	1	192 289	MKRS-16,5-B	193 124	HMZAS-PG-21	193 124	HMZAS-PG-21	5 / 3.3-132
2	1	-		177 572	MKRV-23-PG-21	177 572	MKRV-23-PG-21	5 / 3.3-126
3	1	-		177 599	MKM-PG-21	177 599	MKM-PG-21	5 / 3.3-131
4	1 ¹⁾	177 566	MKR-16,5-PG-16	177 567	MKR-23-PG-21	177 567	MKR-23-PG-21	5 / 3.3-124
5	1	193 949	MKA-PG-29-PG-16-KU	177 595	MKA-PG-29-PG-21	177 595	MKA-PG-29-PG-21	5 / 3.3-129
6	1	177 571	MKRV-16,5-PG-16	177 572	MKRV-23-PG-21	177 572	MKRV-23-PG-21	5 / 3.3-126
7	- ²⁾	186 717	ZBH-7	150 927	ZBH-9	189 653	ZBH-12	-
8	2	M4x25 DIN 912		M5x30 DIN 912		M6x40 DIN 912		-

1) Length depends on the stroke of the drive

2) Centring sleeves are included in the scope of delivery of the mini slide SLT.

Pick & place

Z modules

Mini slides SLT

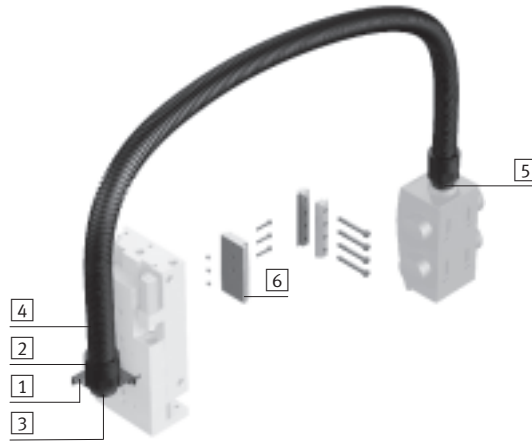

Bill of materials							
Type	HMBSZ-SLT-4		HMBSZ-SLT-5		HMBSZ-SLT-6		→ Page
For drives	SLT-16		SLT-20		SLT-25		
Item	Quantity	Part No.	Type	Part No.	Type	Part No.	
[1]	1	193 124	HMZAS-PG-21	193 124	HMZAS-PG-21	193 124	5 / 3.3-132
[2]	2	177 572	MKRV-23-PG-21	177 572	MKRV-23-PG-21	177 572	5 / 3.3-126
[3]	1	177 599	MKM-PG-21	177 599	MKM-PG-21	177 599	5 / 3.3-131
[4]	1 ¹⁾	177 567	MKR-23-PG-21	177 567	MKR-23-PG-21	177 567	5 / 3.3-124
[5]	1	177 595	MKA-PG-29-PG-21	177 595	MKA-PG-29-PG-21	177 595	5 / 3.3-129
[6]	1	178 331	HMSV-36	178 332	HMSV-37	178 332	5 / 3.2-11

1) Length depends on the stroke of the drive

Pick & place

Z modules

Linear modules HMPL

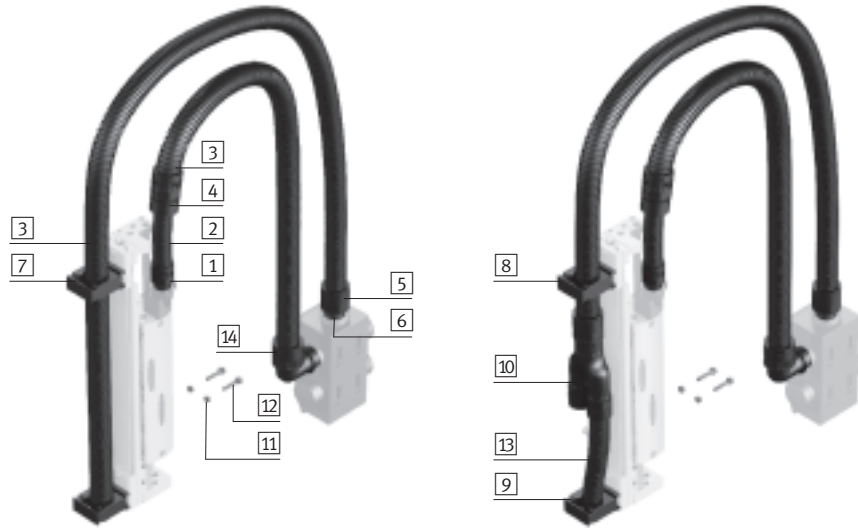

Bill of materials								
Type		HMBSZ-HMPL-1	HMBSZ-HMPL-2	HMBSZ-HMPL-3	HMBSZ-HMPL-4			
For drives		HMPL-12	HMPL-12	HMPL-16	HMPL-16			
		HMPL-16	HMPL-16	HMPL-20	HMPL-20			
		HMPL-20	HMPL-20					
		without intermediate position	with intermediate position	without intermediate position	with intermediate position			
Item	Quantity	Part No.	Type	Part No.	Type	Part No.	Type	→ Page
1	1	177 571	MKRV-16,5-PG-16	177 571	MKRV-16,5-PG-16	177 571	MKRV-16,5-PG-16	5 / 3.3-126
2	1 ¹⁾	177 566	MKR-16,5-PG-16	177 566	MKR-16,5-PG-16	177 566	MKR-16,5-PG-16	5 / 3.3-124
3	2 ¹⁾	177 567	MKR-23-PG-21	177 567	MKR-23-PG-21	177 567	MKR-23-PG-21	
4	1	194 321	MKRT-23-16,5	194 321	MKRT-23-16,5	194 321	MKRT-23-16,5	5 / 3.3-128
5	1	177 572	MKRV-23-PG-21	177 572	MKRV-23-PG-21	177 572	MKRV-23-PG-21	5 / 3.3-126
6	2	177 595	MKA-PG-29-PG-21	177 595	MKA-PG-29-PG-21	177 595	MKA-PG-29-PG-21	5 / 3.3-129
7	2 ²⁾	192 290	MKRS-23-B	-		192 290	MKRS-23-B	5 / 3.3-131
8	1 ²⁾	-		192 290	MKRS-23-B	-		
9	1 ²⁾	-		192 289	MKRS-16,5-B	-		
10	1	-		193 946	MKY-PG-21-2PG-16	-		5 / 3.3-128
11	1 ³⁾	150 927	ZBH-9	150 927	ZBH-9	150 927	ZBH-9	-
12	2	M5x16 DIN 912		M5x16 DIN 912		M5x22 DIN 912		-
13	1 ¹⁾	-		177 566	MKR-16,5-PG-16	-		5 / 3.3-124
14	1	177 577	MKRL-23-PG-21	177 577	MKRL-23-PG-21	177 577	MKRL-23-PG-21	5 / 3.3-127

1) Length depends on the stroke of the drive

2) In order to be able to mount the retaining clip MKRS, a clamping component (2x code I) must be selected as an accessory in the order for the linear module HMPL.

3) 10 per packaging unit

Pick & place

Z modules

Linear modules HMP

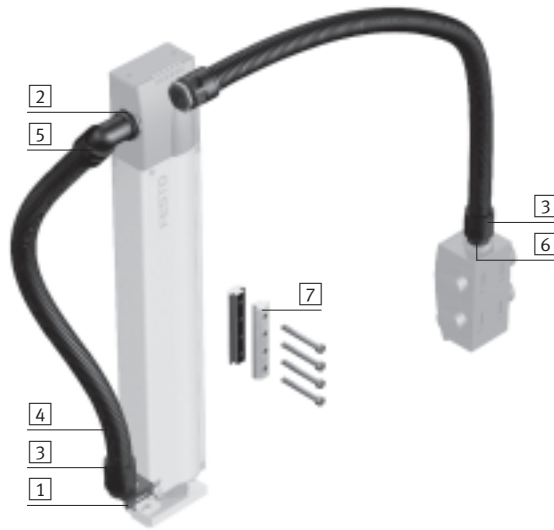

Bill of materials

Type	HMBSZ-HMP-1		HMBSZ-HMP-2		HMBSZ-HMP-3		→ Page
For drives	HMP-16		HMP-20		HMP-25		
Item	Quantity	Part No.	Type	Part No.	Type	Part No.	Type
[1]	1	193 124		177 603		177 603	5 / 3.3-132
		HMZAS-PG-21		HMZAS-PG-29		HMZAS-PG-29	
[2]	3	177 599		177 600		177 600	5 / 3.3-131
		MKM-PG-21		MKM-PG-29		MKM-PG-29	
[3]	3	177 572		177 573		177 573	5 / 3.3-126
		MKRV-23-PG-21		MKRV-29-PG-29		MKRV-29-PG-29	
[4]	2 ¹⁾	177 567		177 568		177 568	5 / 3.3-124
		MKR-23-PG-21		MKR-29-PG-29		MKR-29-PG-29	
[5]	1	177 577		177 578		177 578	5 / 3.3-127
		MKRL-23-PG-21		MKRL-29-PG-29		MKRL-29-PG-29	
[6]	1	177 595		-		-	5 / 3.3-129
		MKA-PG-29-PG-21					
[7]	1	177 647		177 649		177 653	5 / 3.3-114
		HMSV-1		HMSV-3		HMSV-7	

1) Length depends on the stroke of the drive

Pick & place

System example

Combination with handling modules HMPL

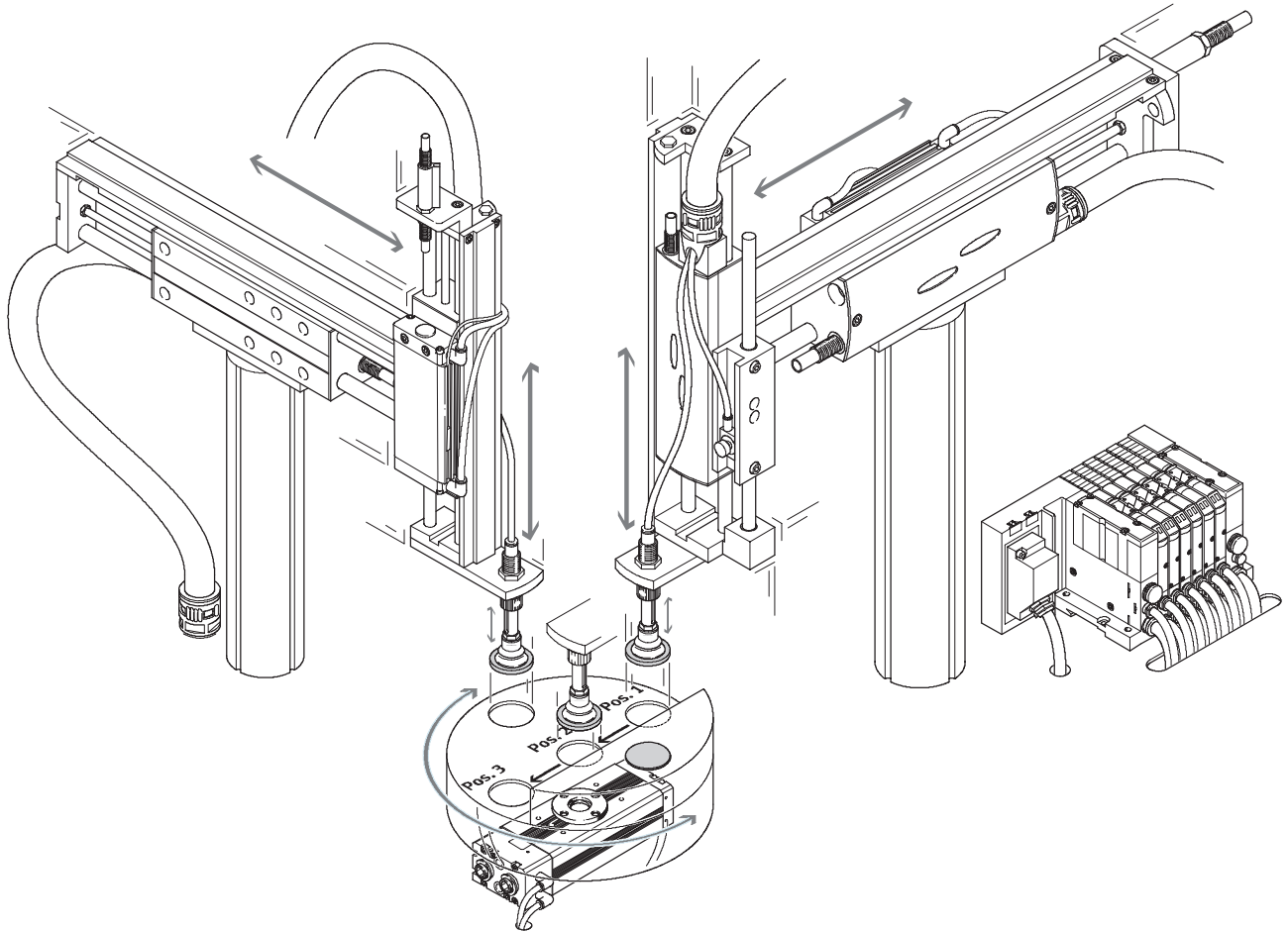

Linear gantries

Key features



Y and Z modules

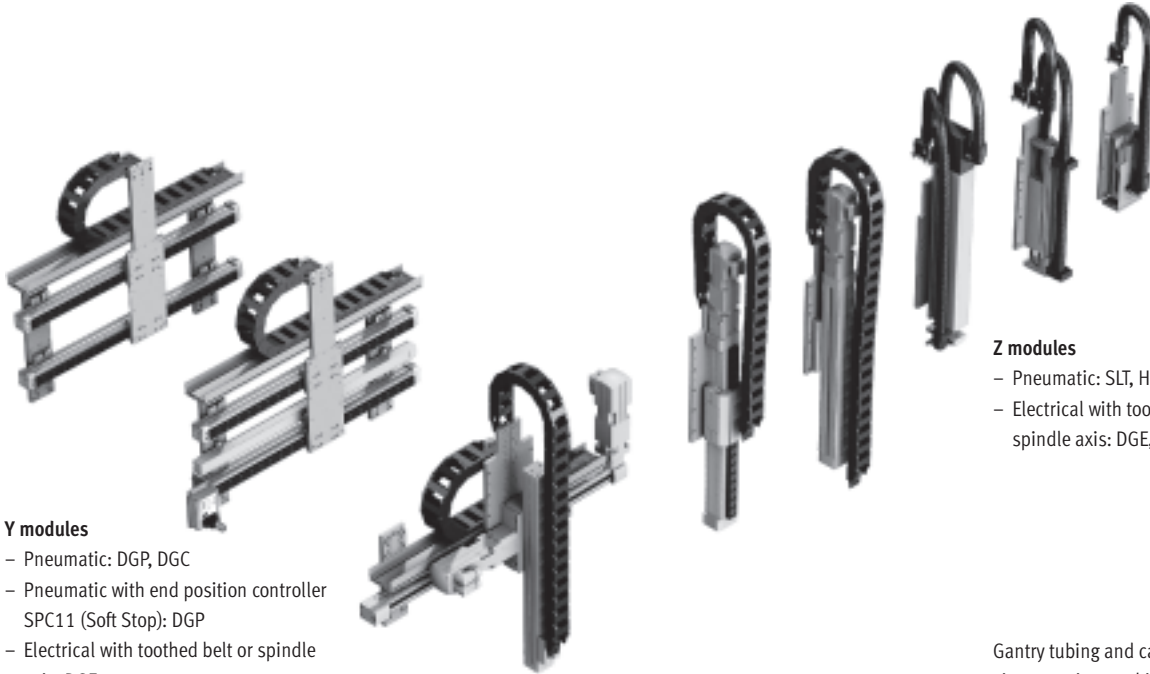

Y modules

- Pneumatic: DGP, DGC
- Pneumatic with end position controller SPC11 (Soft Stop): DGP
- Electrical with toothed belt or spindle axis: DGE
- Single-axis systems (mono) or drives with guide axis (duo)

Z modules

- Pneumatic: SLT, HMPL, HMP
- Electrical with toothed belt or spindle axis: DGE, DGEA

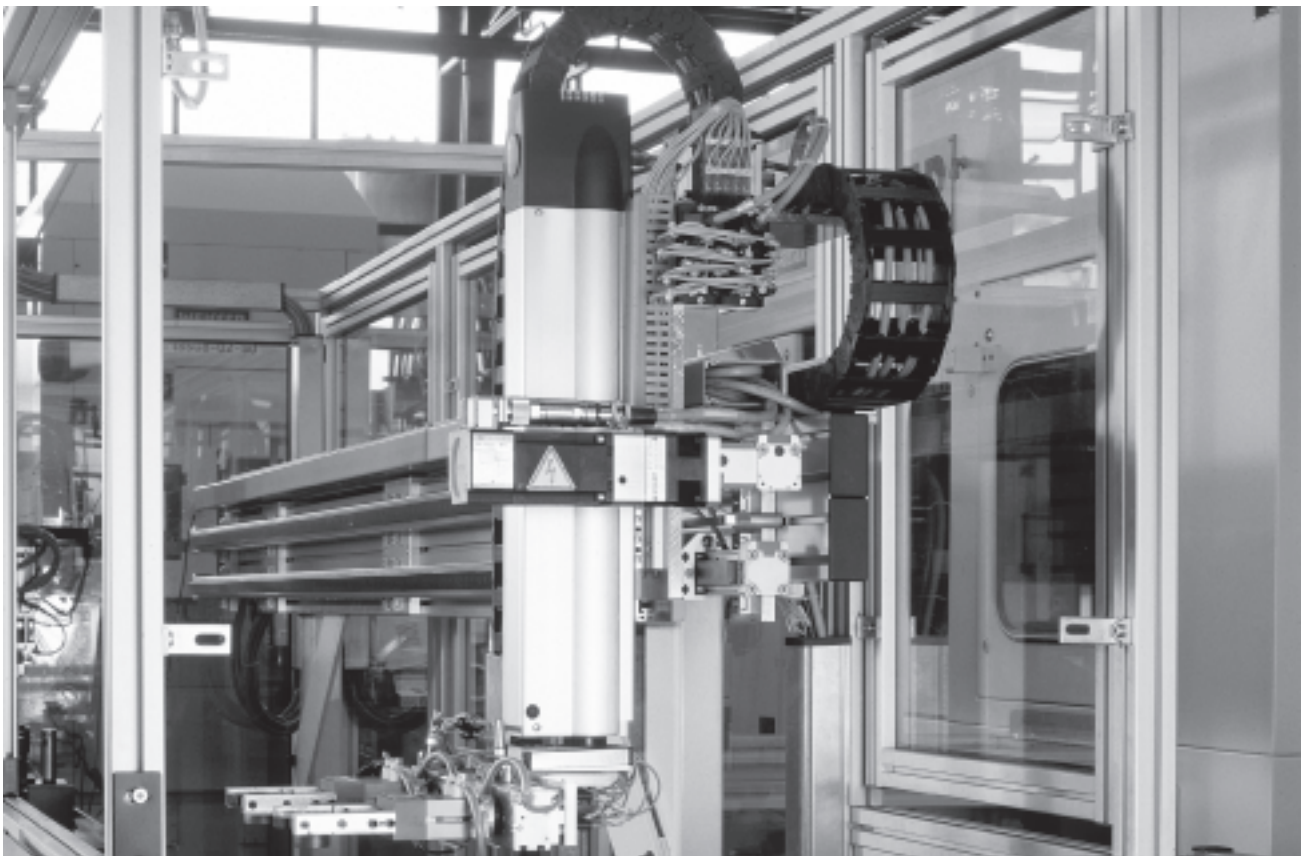

Gantry tubing and cables are routed via protective trunking. Festo uses a base profile for this purpose specially designed for handling technology.

Application



Linear gantries

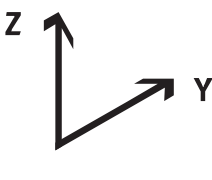

Product range overview

Selection aid				
System type	Mono 25	Mono 40	Duo 25	Duo 40
				
Y-axis	DG...-25	DG...-40	DG...-25	DG...-40
Drive function	Pneumatic, pneumatic with end position controller SPC11 (Soft Stop) or electrical			
Options	Spindle or toothed belt axis			
Z-axis	DGSL-16 SLT-16 HMPL-16	DGSL-20 SLT-20 HMPL-20 HMP-16	DGSL-25 SLT-25 HMP-20	HMP-25
Drive function	Pneumatic			
Options	Intermediate position with HMPL	Intermediate position with HMPL, HMP		Intermediate position with HMP
Z-axis	DGEA-18	DGEA-18 DGE-25-SP-KF	DGEA-25 DGE-40-SP-KF	DGEA-25 DGE-40-SP-KF
Drive function	Electrical			
Options	–	Spindle or toothed belt axis		Spindle or toothed belt axis
Working load [kg]				
	1	■	■	■
	2	■	■	■
	3	–	■	■
	4	–	■	■
	6	–	–	■
	10	–	–	■
→ Page	5 / 3.3-56			

Linear gantries

Selection aid for basic, connection and installation components



Y-axis				
System type	Mono 25	Mono 40	Duo 25	Duo 40
				
Pneumatic drives	Type			
DGPL-25	HMBSY-LP-M25-1 → 5 / 3.3-58	–	HMBSY-LP-D25-1 → 5 / 3.3-60	–
DGC-25	HMBSY-LP-M25-2 → 5 / 3.3-58	–	HMBSY-LP-D25-2 → 5 / 3.3-60	–
DGPL-25 with SPC11	HMBSY-LP-M25-3 → 5 / 3.3-58	–	HMBSY-LP-D25-3 → 5 / 3.3-60	–
DGPL-40	–	HMBSY-LP-M40-1 → 5 / 3.3-59	–	HMBSY-LP-D40-1 → 5 / 3.3-61
DGC-40	–	HMBSY-LP-M40-2 → 5 / 3.3-59	–	HMBSY-LP-D40-2 → 5 / 3.3-61
DGPL-40 with SPC11	–	HMBSY-LP-M40-3 → 5 / 3.3-59	–	HMBSY-LP-D40-3 → 5 / 3.3-61
Electrical drives	Type			
DGE-25 -SP-KF	HMBSY-LP-M25-1 → 5 / 3.3-58	–	HMBSY-LP-D25-1 → 5 / 3.3-60	–
-ZR-KF				
-ZR-RF	HMBSY-LP-M25-4 → 5 / 3.3-58	–	HMBSY-LP-D25-4 → 5 / 3.3-60	–
DGE-40 -SP-KF	–	HMBSY-LP-M40-1 → 5 / 3.3-59	–	HMBSY-LP-D40-1 → 5 / 3.3-61
-ZR-KF				
-ZR-RF				

Selection example:

Project engineering produced the following drive combination:

Y-axis: Duo 25 system with DGE-25-ZR-RF
Z-axis: SLT-20

Step 1

Define the drive type in the selection aids for the Y- or Z-axis. The associated bill of materials can be found on the specified page.

Y-axis: HMBSY-LP-D25-4
→ 5 / 3.3-60
Z-axis: HMBSZ-SLT-7
→ 5 / 3.3-63

Step 2

The necessary basic, connection and installation components can be found in the bill of materials on the specified page.



Y-axis: HMBSY-LP-D25-4
Z-axis: HMBSZ-SLT-7

Step 3

Technical data on the basic, connection and installation components can be found on the specified pages. Further accessories for the selected drives, for example proximity sensors, centring sleeves, etc. are documented with the drives.

Linear gantries

Selection aid for basic, connection and installation components

Z-axis				
System type	Mono 25	Mono 40	Duo 25	Duo 40
				
Pneumatic drives	Type			
DGSL-16	HMBSZ-DGSL-7 → 5 / 3.3-62	–	–	–
DGSL-20	–	HMBSZ-DGSL-8 → 5 / 3.3-62	–	–
DGSL-25	–	HMBSZ-DGSL-8 → 5 / 3.3-62	HMBSZ-DGSL-8 → 5 / 3.3-62	–
SLT-16	HMBSZ-SLT-7 → 5 / 3.3-63	–	–	–
SLT-20	–	HMBSZ-SLT-7 → 5 / 3.3-63	HMBSZ-SLT-7 → 5 / 3.3-63	–
SLT-25	–	–	HMBSZ-SLT-7 → 5 / 3.3-63	–
HMPL-16	HMBSZ-HMPL-5 HMBSZ-HMPL-6 → 5 / 3.3-64	–	–	–
HMPL-20	–	HMBSZ-HMPL-5 HMBSZ-HMPL-6 → 5 / 3.3-64	HMBSZ-HMPL-5 HMBSZ-HMPL-6 → 5 / 3.3-64	–
HMP-16	–	HMBSZ-HMP-4 → 5 / 3.3-65	HMBSZ-HMP-4 → 5 / 3.3-65	–
HMP-20	–	–	HMBSZ-HMP-5 → 5 / 3.3-65	–
HMP-25	–	–	–	HMBSZ-HMP-6 → 5 / 3.3-65
Electrical drives	Type			
DGEA-18	HMBSZ-DGEA-1 → 5 / 3.3-66	HMBSZ-DGEA-1 → 5 / 3.3-66	HMBSZ-DGEA-1 → 5 / 3.3-66	–
DGEA-25	–	–	HMBSZ-DGEA-2 → 5 / 3.3-66	HMBSZ-DGEA-3 → 5 / 3.3-66
DGE-25-SP	–	HMBSZ-DGE-1 → 5 / 3.3-67	HMBSZ-DGE-1 → 5 / 3.3-67	–
DGE-40-SP	–	–	HMBSZ-DGE-2 → 5 / 3.3-67	HMBSZ-DGE-3 → 5 / 3.3-67

Linear gantries

Y modules



Mono system

Toothed belt axes DGE, linear drives DGC, DGPL

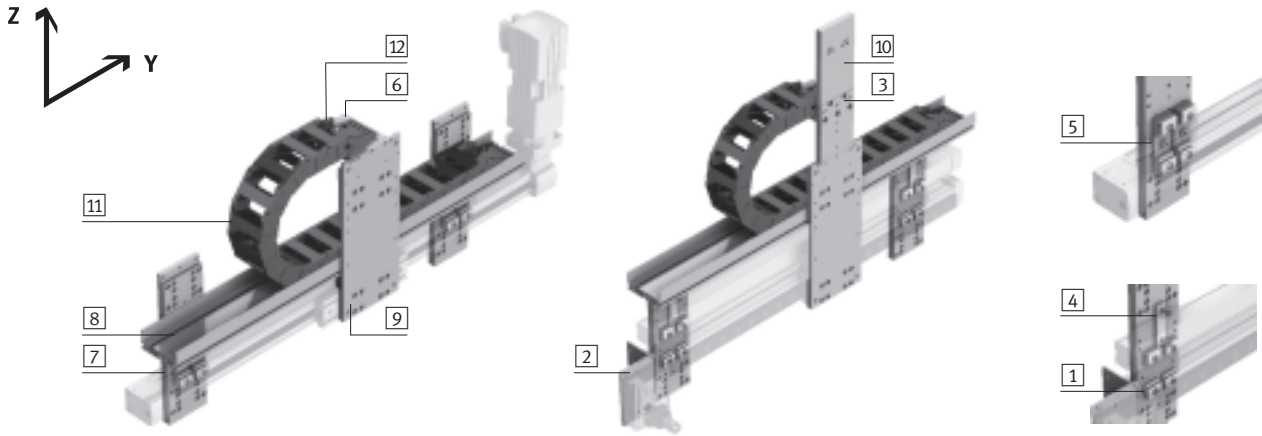

Bill of materials

Type	HMBSY-LP-M25-1	HMBSY-LP-M25-2	HMBSY-LP-M25-3	HMBSY-LP-M25-4				
For drives	DGPL-25 DGE-25-SP-KF DGE-25-ZR-KF	DGC-25	DGPL-25 with SPC11	DGE-25-ZR-RF				
System type	Mono 25							
Item	Quantity	Part No.	Type	Part No.	Type	Part No.	Type	→ Page
1	2 ¹⁾	150 736		–		150 736	150 736	Volume 1
	1 ¹⁾	–		531 753		–	–	Volume 1
		MUP-18/25		MUC-25		MUP-18/25	MUP-18/25	
2	1	–		–		539 367	–	99
						HMVW-SPC		
3	1	–		–		539 364	–	5 / 3.3-140
						HMIM-LP		
4	1 ¹⁾	–		–		539 973	–	98
						HMVO-POT		
5	2 ¹⁾	–		–		–	539 362	98
							HMVO-RF25	
6	1	539 366		539 366		539 366	539 366	5 / 3.3-140
		HMIO-AP1		HMIO-AP1		HMIO-AP1	HMIO-AP1	
7	2 ²⁾	539 972		539 972		539 972	539 972	94
		HMVM-LP-DL25/40		HMVM-LP-DL25/40		HMVM-LP-DL25/40	HMVM-LP-DL25/40	
8	1 ³⁾	539 378		539 378		539 378	539 378	5 / 3.3-139
		HMIA-E05		HMIA-E05		HMIA-E05	HMIA-E05	
9	1	539 368		539 368		539 368	539 368	96
		HMVS-DL25		HMVS-DL25		HMVS-DL25	HMVS-DL25	
10	1	–		–		539 365	–	5 / 3.3-138
						HMIZB-E03		
11	1	IGUS E2 medium 240.05.100 and 211 or KABELSCHLEPP MC 0320.60-01-100 and TS O/h _T 2						–
12	1	IGUS E2 medium 2050.12.PZB or KABELSCHLEPP MC FA/MA						–

1) Per basic kit HMVM-LP-DL25/40

2) Quantity with stroke ≤ 500 mm. With stroke > 500 mm, a basic kit HMVM-LP-DL25/40 must be additionally ordered per 500 mm stroke or part thereof.

3) Length depends on the stroke of the drive

Linear gantries

Y modules

Mono system

Toothed belt axes DGE, linear drives DGC, DGPL

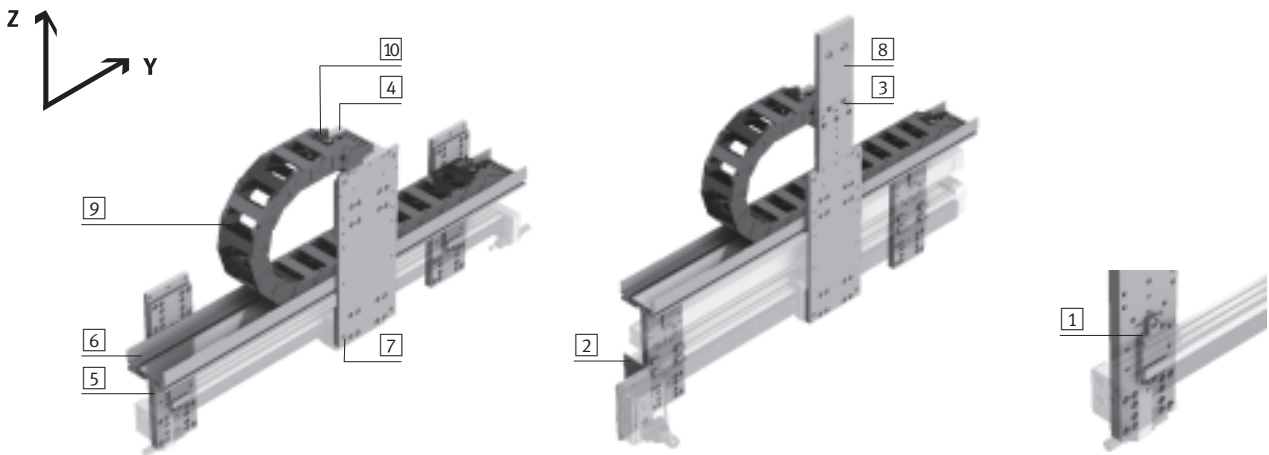

Bill of materials									
Type	HMBSY-LP-M40-1		HMBSY-LP-M40-2		HMBSY-LP-M40-3				
For drives	DGPL-40 DGE-40-SP-KF DGE-40-ZR-KF DGE-40-ZR-RF		DGC-40		DGPL-40 with SPC11				
System type	Mono 40								
Item	Quantity	Part No.	Type	Part No.	Type	Part No.	Type	→ Page	
1	1 ¹⁾	-		531 755 MUC-40		-		Volume 1	
2	1	-		-		539 367 HMVW-SPC		99	
3	1	-		-		539 364 HMIM-LP		5 / 3.3-140	
4	1	539 366 HMIO-AP-1		540 121 HMIO-AP-2		539 366 HMIO-AP-1		5 / 3.3-140	
5	2 ²⁾	539 972 HMVM-LP-DL25/40		539 972 HMVM-LP-DL25/40		539 972 HMVM-LP-DL25/40		94	
6	1 ³⁾	539 378 HMIA-E05		539 378 HMIA-E05		539 378 HMIA-E05		5 / 3.3-139	
7	1	539 369 HMVS-DL40		539 369 HMVS-DL40		539 369 HMVS-DL40		96	
8	1	-		-		539 365 HMIZB-E03		5 / 3.3-138	
9	1	IGUS E2 medium 240.05.100 and 211 or KABELSCHLEPP MC 0320.60-01-100 and TS O/n _T 2							-
10	1	IGUS E2 medium 2050.12.PZB or KABELSCHLEPP MC FA/MA							-

1) Per basic kit HMVM-LP-DL25/40

2) Quantity with stroke ≤ 500 mm. With stroke > 500 mm, a basic kit HMVM-LP-DL25/40 must be additionally ordered per 500 mm stroke or part thereof.

3) Length depends on the stroke of the drive

Linear gantries

Y modules



Duo system

Toothed belt axes DGE, linear drives DGC, DGPL

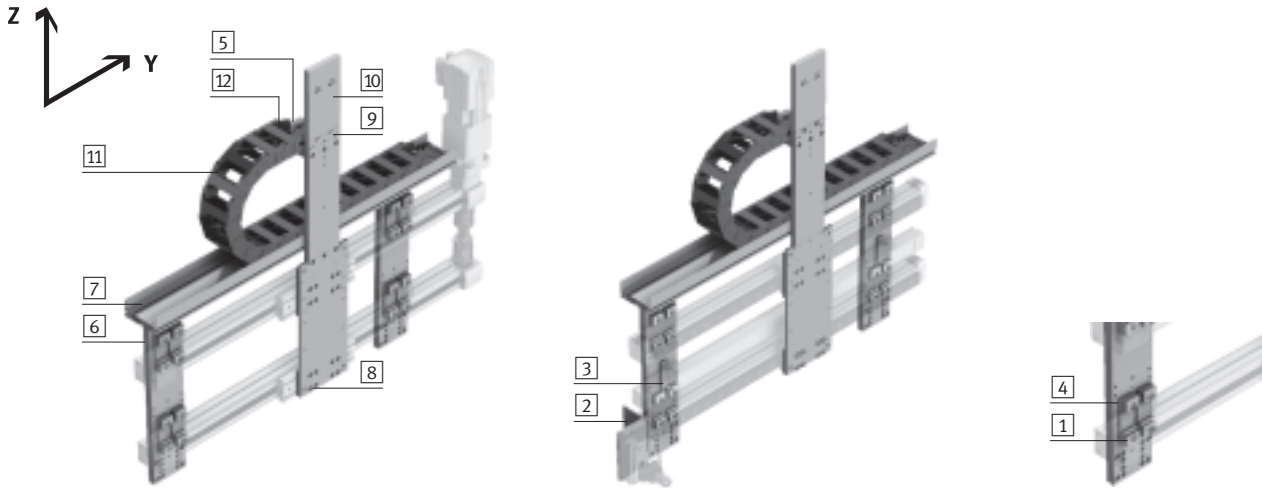

Bill of materials

Type	HMBSY-LP-D25-1	HMBSY-LP-D25-2	HMBSY-LP-D25-3	HMBSY-LP-D25-4							
For drives	DGPL-25 DGE-25-SP-KF DGE-25-ZR-KF	DGC-25	DGPL-25 with SPC11	DGE-25-ZR-RF							
System type	Duo 25										
Item	Quantity	Part No.	Type	Part No.	Type	Part No.	Type	Part No.	Type	→ Page	
1	4 ¹⁾	150 736		–		150 736		150 736		Volume 1	
	2 ¹⁾	–		531 753		–		–		Volume 1	
		MUP-18/25		MUC-25		MUP-18/25		MUP-18/25			
2	1	–		–		539 367		–		99	
						HMVW-SPC					
3	1 ¹⁾	–		–		539 973		–		98	
						HMVO-POT					
4	4 ¹⁾	–		–		–		539 362		98	
								HMVO-RF25			
5	1	539 366		539 366		539 366		539 366		5 / 3.3-140	
		HMIO-AP-1		HMIO-AP-1		HMIO-AP-1		HMIO-AP-1			
6	2 ²⁾	539 971		539 971		539 971		539 971		94	
		HMVD-LP-DL25/40		HMVD-LP-DL25/40		HMVD-LP-DL25/40		HMVD-LP-DL25/40			
7	1 ³⁾	539 378		539 378		539 378		539 378		5 / 3.3-139	
		HMIA-E05		HMIA-E05		HMIA-E05		HMIA-E05			
8	1	539 368		539 368		539 368		539 368		96	
		HMVS-DL25		HMVS-DL25		HMVS-DL25		HMVS-DL25			
9	1	539 363		539 363		539 363		539 363		5 / 3.3-140	
		HMID-LP		HMID-LP		HMID-LP		HMID-LP			
10	1	539 365		539 365		539 365		539 365		5 / 3.3-138	
		HMIZB-E03		HMIZB-E03		HMIZB-E03		HMIZB-E03			
11	1	IGUS E2 medium 240.05.100 and 211 or KABELSCHLEPP MC 0320.60-01-100 and TS O/n _T 2									–
12	1	IGUS E2 medium 2050.12.PZB or KABELSCHLEPP MC FA/MA									–

1) Per basic kit HMVD-LP-DL25/40

2) Quantity with stroke ≤ 500 mm. With stroke > 500 mm, a basic kit HMVD-LP-DL25/40 must be additionally ordered per 500 mm stroke or part thereof.

3) Length depends on the stroke of the drive

Linear gantries

Y modules

Duo system

Toothed belt axes DGE, linear drives DGC, DGPL

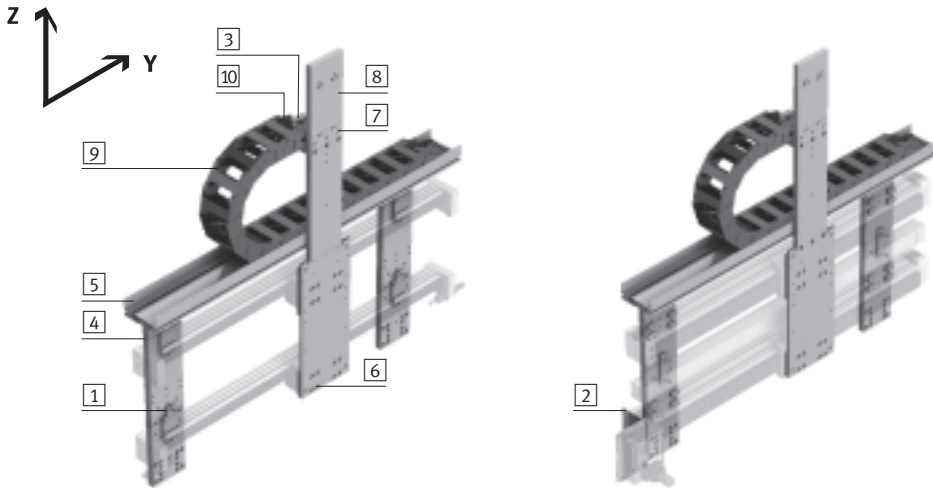

Bill of materials								
Type	HMBSY-LP-D40-1		HMBSY-LP-D40-2		HMBSY-LP-D40-3		→ Page	
For drives	DGPL-40 DGE-40-SP-KF DGE-40-ZR-KF DGE-40-ZR-RF		DGC-40		DGPL-40 with SPC11			
System type	Duo 40							
Item	Quantity	Part No.	Type	Part No.	Type	Part No.		Type
1	2 ¹⁾	–		531 755 MUC-40		–		Volume 1
2	1	–		–		539 367 HMVW-SPC		99
3	1	539 366 HMIO-AP-1		540 121 HMIO-AP-2		539 366 HMIO-AP-1		5 / 3.3-140
4	2 ²⁾	539 971 HMVD-LP-DL25/40		539 971 HMVD-LP-DL25/40		539 971 HMVD-LP-DL25/40		94
5	1 ³⁾	539 378 HMIA-E05		539 378 HMIA-E05		539 378 HMIA-E05		5 / 3.3-139
6	1	539 369 HMVS-DL40		539 369 HMVS-DL40		539 369 HMVS-DL40		96
7	1	539 363 HMID-LP		539 363 HMID-LP		539 363 HMID-LP		5 / 3.3-140
8	1	539 365 HMIZB-E03		539 365 HMIZB-E03		539 365 HMIZB-E03		5 / 3.3-138
9	1	IGUS E2 medium 240.05.100 and 211 or KABELSCHLEPP MC 0320.60-01-100 and TS 0/n _T 2						–
10	1	IGUS E2 medium 2050.12.PZB or KABELSCHLEPP MC FA/MA						–

1) Per basic kit HMVD-LP-DL25/40

2) Quantity with stroke ≤ 500 mm. With stroke > 500 mm, a basic kit HMVD-LP-DL25/40 must be additionally ordered per 500 mm stroke or part thereof.

3) Length depends on the stroke of the drive

Linear gantries

Z modules



Z modules
Mini slides DGSL

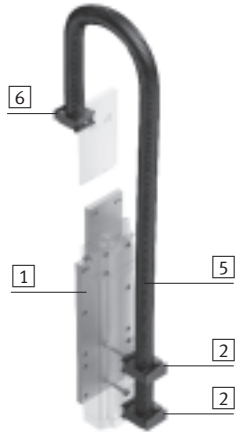

System components
Multi-axis modular system

3.3

Bill of materials							
Type		HMBSZ-DGSL-7		HMBSZ-DGSL-8			
For drives		DGSL-16		DGSL-20		DGSL-25	
System type		Mono 25		Mono 40 Duo 25		Duo 25	
Item	Quantity	Part No.	Type	Part No.	Type	Part No.	Type
[1]	1	539 373	HMVZ-2	539 373	HMVZ-2	539 373	HMVZ-2
[2]	1	192 289	MKRS-16,5-B	192 290	MKRS-23-B	192 290	MKRS-23-B
		548 803	ZBV-M5-7	548 804	ZBV-M5-9	548 804	ZBV-M5-9
[5]	1 ¹⁾	177 566	MKR-16,5-PG-16	177 567	MKR-23-PG-21	177 567	MKR-23-PG-21
[6]	1	192 289	MKRS-16,5-B	192 290	MKRS-23-B	192 290	MKRS-23-B

1) Length depends on the stroke of the drive

Linear gantries

Z modules

Mono/Duo system

Mini slides SLT

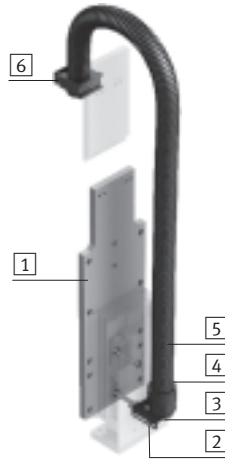

Bill of materials							
Type		HMBSZ-SLT-7					
For drives		SLT-16		SLT-20		SLT-25	
System type		Mono 25		Mono 40 Duo 25		Duo 25	
Item	Quantity	Part No.	Type	Part No.	Type	Part No.	Type
1	1	539 373	HMVZ-2	539 373	HMVZ-2	539 373	HMVZ-2
2	1	193 124	HMZAS-PG-21	193 124	HMZAS-PG-21	193 124	HMZAS-PG-21
3	1	177 599	MKM-PG-21	177 599	MKM-PG-21	177 599	MKM-PG-21
4	1	177 572	MKRV-23-PG-21	177 572	MKRV-23-PG-21	177 572	MKRV-23-PG-21
5	1 ¹⁾	177 567	MKR-23-PG-21	177 567	MKR-23-PG-21	177 567	MKR-23-PG-21
6	1	192 290	MKRS-23-B	192 290	MKRS-23-B	192 290	MKRS-23-B

1) Length depends on the stroke of the drive

Linear gantries

Z modules



Mono/Duo system

Linear modules HMPL

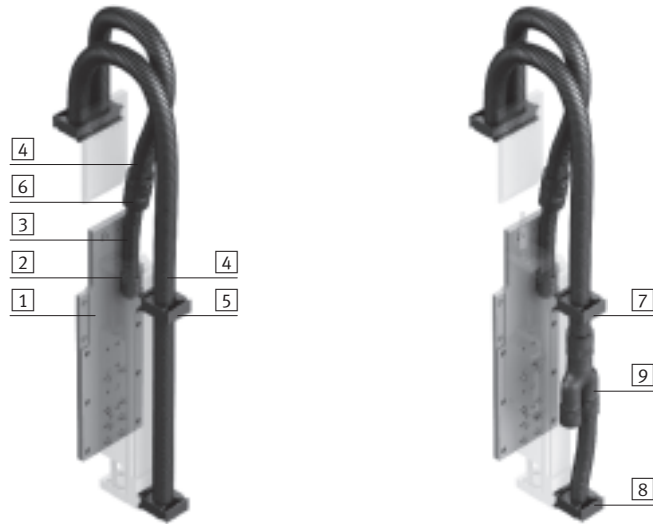

Bill of materials

Type		HMBSZ-HMPL-5		HMBSZ-HMPL-6		→ Page		
For drives		HMPL-16	HMPL-20	HMPL-16	HMPL-20			
		without intermediate position		with intermediate position				
System type		Mono 25	Mono 40 Duo 25	Mono 25	Mono 40 Duo 25			
Item	Quantity	Part No.	Type	Part No.	Type	Part No.	Type	
1	1	539 375	HMVZ-4	539 375	HMVZ-4	539 375	HMVZ-4	97
2	1	177 571	MKRV-16,5-PG-16	177 571	MKRV-16,5-PG-16	177 571	MKRV-16,5-PG-16	5 / 3.3-126
3	1 ¹⁾	177 566	MKR-16,5-PG-16	177 566	MKR-16,5-PG-16	177 566	MKR-16,5-PG-16	5 / 3.3-124
4	1 ²⁾	177 567	MKR-23-PG-21	177 567	MKR-23-PG-21	177 567	MKR-23-PG-21	
5	4 ³⁾	192 290	MKRS-23-B	192 290	MKRS-23-B	–	–	5 / 3.3-131
6	1	194 321	MKRT-23-16,5	194 321	MKRT-23-16,5	194 321	MKRT-23-16,5	5 / 3.3-128
7	3 ³⁾	–	–	–	–	192 290	MKRS-23-B	5 / 3.3-131
8	1	–	–	–	–	192 289	MKRS-16,5-B	
9	1	–	–	–	–	193 946	MKY-PG-21-2PG-16	5 / 3.3-128

1) Length 200 mm

2) Length depends on the stroke of the drive, 2 conduits are required with an intermediate position.

3) In order to be able to mount the retaining clip MKRS, a clamping component (2x code J) must be selected as an accessory in the order for the linear module HMPL.

Linear gantries

Z modules

Mono/Duo system
Linear modules HMP

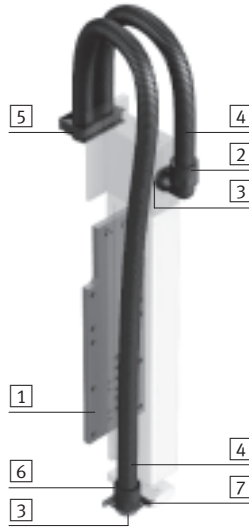

Bill of materials							
Type		HMBSZ-HMP-4		HMBSZ-HMP-5		HMBSZ-HMP-6	
For drives		HMP-16		HMP-20		HMP-25	
System type		Mono 40 Duo 25		Duo 25		Duo 40	
Item	Quantity	Part No.	Type	Part No.	Type	Part No.	Type
1	1	539 374	HMVZ-3	539 374	HMVZ-3	539 377	HMVZ-6
2	1	177 577	MKRL-23-PG-21	177 578	MKRL-29-PG-29	177 578	MKRL-29-PG-29
3	2	177 599	MKM-PG-21	177 600	MKM-PG-29	177 600	MKM-PG-29
4	1 ¹⁾	177 567	MKR-23-PG-21	177 568	MKR-29-PG-29	177 568	MKR-29-PG-29
5	2	192 290	MKRS-23-B	192 291	MKRS-29-B	192 291	MKRS-29-B
6	1	177 572	MKRV-23-PG-21	177 573	MKRV-29-PG-29	177 573	MKRV-29-PG-29
7	1	193 124	HMZAS-PG-21	177 603	HMZAS-PG-29	177 603	HMZAS-PG-29

1) Length depends on the stroke of the drive

Linear gantries

Z modules

Mono/Duo system
Cantilever axes DGEA

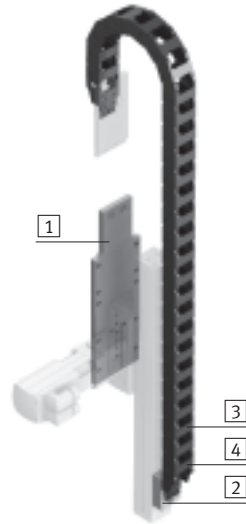

Bill of materials									
Type		HMBSZ-DGEA-1		HMBSZ-DGEA-2		HMBSZ-DGEA-3		→ Page	
For drives		DGEA-18		DGEA-25		DGEA-25			
System type		Mono 25 Mono 40 Duo 25		Duo 25		Duo 40			
Item	Quantity	Part No.	Type	Part No.	Type	Part No.	Type		
[1]	1	539 374 HMVZ-3		539 375 HMVZ-4		539 377 HMVZ-6		97	
[2]	1	539 370 HMIZF-E03-DA18		539 371 HMIZF-E03-DA25		539 371 HMIZF-E03-DA25		5 / 3.3-138	
[3]	1 ¹⁾	IGUS E2 medium 240.03.075.0 and 211 or KABELSCHLEPP MC 0320.40-01-77 and TS 0/n _T 2							-
[4]	1	IGUS E2 medium 2030.12.PZB or KABELSCHLEPP MC FA/MA							-

1) Length depends on the stroke of the drive

Linear gantries

Z modules

Mono/Duo system

Spindle axes DGE

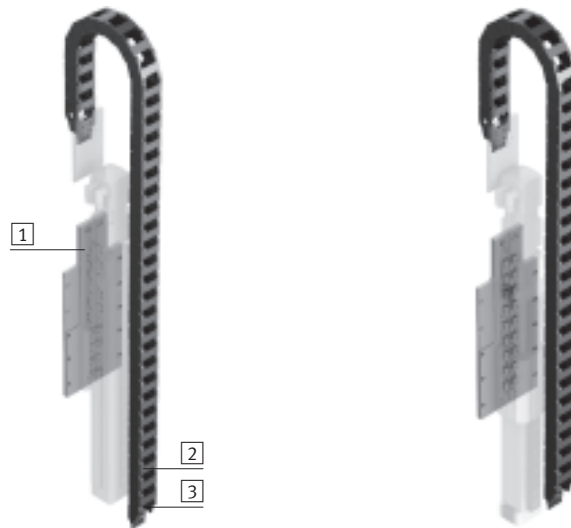

Bill of materials								
Type	HMBSZ-DGE-1		HMBSZ-DGE-2		HMBSZ-DGE-3			
For drives	DGE-25-SP		DGE-40-SP		DGE-40-SP			
System type	Mono 40 Duo 25		Duo 25		Duo 40			
Item	Quantity	Part No.	Type	Part No.	Type	Part No.	Type	
1	1	539 374	HMVZ-3	539 375	HMVZ-4	539 377	HMVZ-6	
2	1 ¹⁾	IGUS E2 medium 240.03.075.0 and 211 or KABELSCHLEPP MC 0320.40-01-77 and TS O/nT2						-
3	1	IGUS E2 medium 2030.12.PZB or KABELSCHLEPP MC FA/MA						-

1) Length depends on the stroke of the drive

3-Dimensional gantries

Key features



System components
Multi-axis modular system

3.3

X, Y and Z modules



Y modules

- Pneumatic: DGP, DGC
- Electrical with toothed belt or spindle axis: DGE
- Single-axis systems (mono) or drives with guide axis (duo)

X modules

- Electrical with toothed belt axis: DGE

Z modules

- Pneumatic: SLT, HMPL, HMP
- Electrical with toothed belt or spindle axis: DGE, DGEA





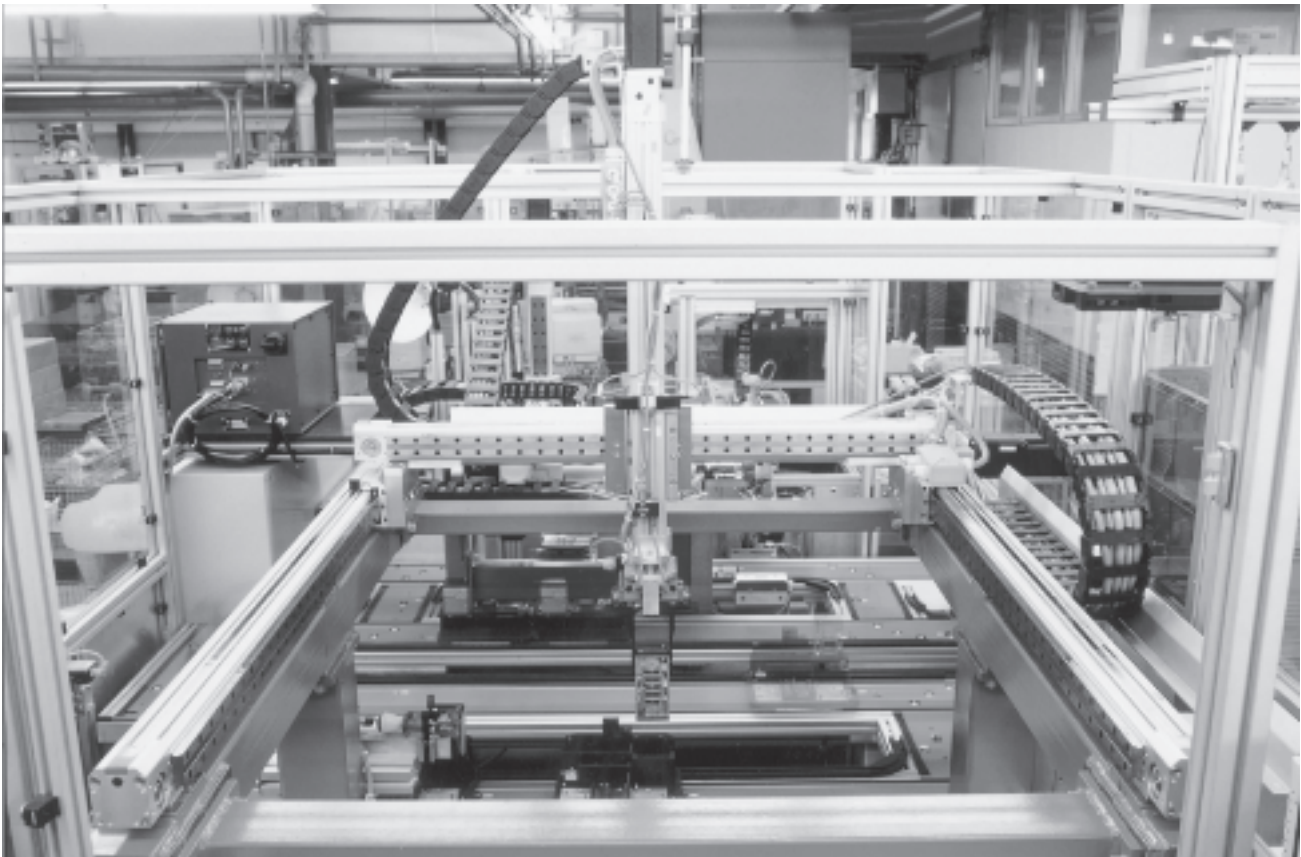

The components in the multi-axis modular system consist mainly of aluminium plates that are connected to each other and attached to the drives using screw connections and slot nut connectors. This permits fast and easy assembly.

Application

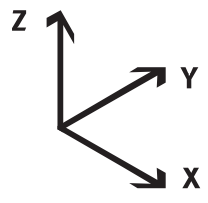

3-Dimensional gantries

Product range overview

Selection aid					
System type	Mono 25	Mono 40	Duo 25		Duo 40
					
X-axis	DGE-25-ZR	DGE-40-ZR	DGE-25-ZR	DGE-40-ZR	DGE-40-ZR
Drive function	Electrical				
Options	Ball bearing or roller guide				
Y-axis	DG...-25	DG...-40	DG...-25	DG...-40	
					
Drive function	Pneumatic and electrical				
Options	Spindle or toothed belt axis				
Z-axis	DGSL-16 SLT-16 HMPL-16	DGSL-20 SLT-20 HMPL-20 HMP-16	DGSL-25 SLT-25 HMP-20	HMP-25	
Drive function	Pneumatic				
Options	Intermediate position with HMPL	Intermediate position with HMPL, HMP		Intermediate position with HMP	
Z-axis	DGEA-18	DGEA-18 DGE-25-SP-KF	DGEA-25 DGE-40-SP-KF	DGEA-25 DGE-40-SP-KF	
Drive function	Electrical				
Options	-	Spindle or toothed belt axis		Spindle or toothed belt axis	
Working load [kg]					
	1	■	■	■	■
	2	■	■	■	■
	3	-	■	■	■
	4	-	■	■	■
	6	-	-	■	■
	10	-	-	-	■
→ Page	5 / 3.3-70				

3-Dimensional gantries

Selection aid for basic, connection and installation components



X-axis					
System type		Mono 25	Mono 40	Duo 25	Duo 40
Electrical drives	Type				
DGE-25	-ZR-KF	HMBSX-RP/FP-25-1 → 5 / 3.3-73	HMBSX-RP/FP-25-1 → 5 / 3.3-73	HMBSX-RP/FP-25-1 → 5 / 3.3-73	–
	-ZR-RF	HMBSX-RP/FP-25-2 → 5 / 3.3-73	HMBSX-RP/FP-25-2 → 5 / 3.3-73	HMBSX-RP/FP-25-2 → 5 / 3.3-73	–
DGE-40	-ZR-KF	–	HMBSX-RP/FP-40-1 → 5 / 3.3-73	HMBSX-RP/FP-40-1 → 5 / 3.3-73	HMBSX-RP/FP-40-1 → 5 / 3.3-73
	-ZR-RF	–	HMBSX-RP/FP-40-2 → 5 / 3.3-73	HMBSX-RP/FP-40-2 → 5 / 3.3-73	HMBSX-RP/FP-40-2 → 5 / 3.3-73

Selection example:

Project engineering produced the following drive combination:

Step 1
Define the drive type in the selection aids for the X-, Y- or Z-axis. The associated bill of materials can be found on the specified page.

Step 2
The necessary basic, connection and installation components can be found in the bill of materials on the specified page.

Step 3
Technical data on the basic, connection and installation components can be found on the specified pages. Further accessories for the selected drives, for example proximity sensors, centring sleeves, etc. are documented with the drives.

X-axis: DGE-40-ZR-KF

X-axis: HMBSX-RP/FP-40-1
→ 5 / 3.3-73

X-axis: HMBSX-RP/FP-40-1

Y-axis: Mono 40 system with DGC-40

Y-axis: HMBSY-RP/FP-M40-2
→ 5 / 3.3-74

Y-axis: HMBSY-RP/FP-M40-2



Z-axis: HMPL-20 without intermediate position

Z-axis: HMBSZ-HMPL-5 or 6
→ 5 / 3.3-78

Z-axis: HMBSZ-HMPL-5

3-Dimensional gantries



Selection aid for basic, connection and installation components

Y-axis					
System type	Mono 25	Mono 40	Duo 25	Duo 40	
					
Pneumatic drives	Type				
DGPL-25	HMBSY-RP/FP-M25-1 → 5 / 3.3-74	-	HMBSY-RP/FP-D25-1 → 5 / 3.3-75	-	
DGC-25	HMBSY-RP/FP-M25-2 → 5 / 3.3-74	-	HMBSY-RP/FP-D25-2 → 5 / 3.3-75	-	
DGPL-40	-	HMBSY-RP/FP-M40-1 → 5 / 3.3-74	-	HMBSY-RP/FP-D40-1 → 5 / 3.3-75	
DGC-40	-	HMBSY-RP/FP-M40-2 → 5 / 3.3-74	-	HMBSY-RP/FP-D40-2 → 5 / 3.3-75	
Electrical drives	Type				
DGE-25 -SP-KF -ZR-KF -ZR-RF	HMBSY-RP/FP-M25-1 → 5 / 3.3-74	-	HMBSY-RP/FP-D25-1 → 5 / 3.3-75	-	
DGE-40 -SP-KF -ZR-KF -ZR-RF	-	HMBSY-RP/FP-M40-1 → 5 / 3.3-74	-	HMBSY-RP/FP-D40-1 → 5 / 3.3-75	

3-Dimensional gantries

Selection aid for basic, connection and installation components

FESTO

Z-axis				
System type	Mono 25	Mono 40	Duo 25	Duo 40
				
Pneumatic drives	Type			
DGSL-16	HMBSZ-DGSL-7 → 5 / 3.3-76	-	-	-
DGSL-20	-	HMBSZ-DGSL-8 → 5 / 3.3-76	-	-
DGSL-25	-	HMBSZ-DGSL-8 → 5 / 3.3-76	HMBSZ-DGSL-8 → 5 / 3.3-76	-
SLT-16	HMBSZ-SLT-7 → 5 / 3.3-77	-	-	-
SLT-20	-	HMBSZ-SLT-7 → 5 / 3.3-77	HMBSZ-SLT-7 → 5 / 3.3-77	-
SLT-25	-	-	HMBSZ-SLT-7 → 5 / 3.3-77	-
HMPL-16	HMBSZ-HMPL-5 HMBSZ-HMPL-6 → 5 / 3.3-78	-	-	-
HMPL-20	-	HMBSZ-HMPL-5 HMBSZ-HMPL-6 → 5 / 3.3-78	HMBSZ-HMPL-5 HMBSZ-HMPL-6 → 5 / 3.3-78	-
HMP-16	-	HMBSZ-HMP-4 → 5 / 3.3-79	HMBSZ-HMP-4 → 5 / 3.3-79	-
HMP-20	-	-	HMBSZ-HMP-5 → 5 / 3.3-79	-
HMP-25	-	-	-	HMBSZ-HMP-6 → 5 / 3.3-79
Electrical drives	Type			
DGEA-18	HMBSZ-DGEA-1 → 5 / 3.3-80	HMBSZ-DGEA-1 → 5 / 3.3-80	HMBSZ-DGEA-1 → 5 / 3.3-80	-
DGEA-25	-	-	HMBSZ-DGEA-2 v5 / 3.3-80	HMBSZ-DGEA-3 → 5 / 3.3-80
DGE-25-SP	-	HMBSZ-DGE-1 → 5 / 3.3-81	HMBSZ-DGE-1 → 5 / 3.3-81	-
DGE-40-SP	-	-	HMBSZ-DGE-2 → 5 / 3.3-81	HMBSZ-DGE-3 → 5 / 3.3-81

3-Dimensional gantries

X modules

Basic system

Toothed belt axes DGE

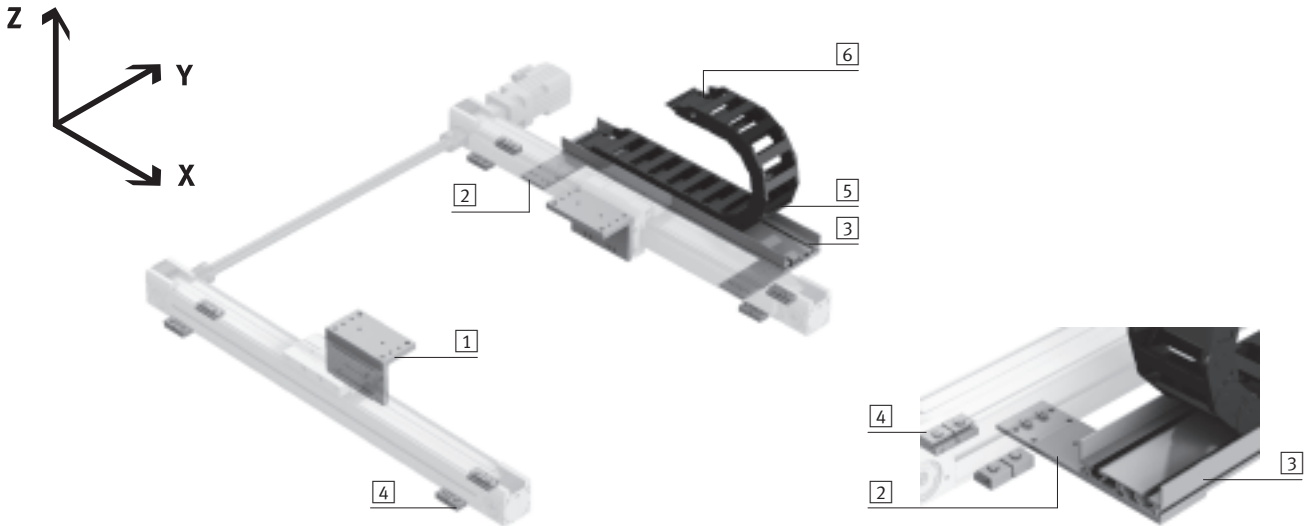

Bill of materials										
Type	HMBSX-RP/FP-25-1		HMBSX-RP/FP-25-2		HMBSX-RP/FP-40-1		HMBSX-RP/FP-40-2		Page	
For drives	DGE-25-ZR-KF		DGE-25-ZR-RF		DGE-40-ZR-KF		DGE-40-ZR-RF			
Item	Quantity	Part No.	Type	Part No.	Type	Part No.	Type	Part No.	Type	
1	1	539 651	HMVW-DL25	539 652	HMVS-RF25	540 325	HMVW-DL40	539 653	HMVS-RF40	91
2	2 ¹⁾	539 654	HMIXB-RP/FP	539 654	HMIXB-RP/FP	539 654	HMIXB-RP/FP	539 654	HMIXB-RP/FP	5 / 3.3-141
3	1 ²⁾	539 379	HMIA-E07	539 379	HMIA-E07	539 379	HMIA-E07	539 379	HMIA-E07	5 / 3.3-139
4	2 ³⁾	150 736	MUP-18/25	150 736	MUP-18/25	-	-	-	-	Volume 1
	1 ³⁾	-	-	-	-	150 738	MUP-40	150 738	MUP-40	Volume 1
5	1 ²⁾	IGUS E2 medium 240.07.100.0 and 211 or KABELSCHLEPP MC 0320.80-01 and TS O/n _T 2							-	
6	1	IGUS E2 medium 2070.12.PZB or KABELSCHLEPP MC FA/MA							-	

- 1) Quantity with stroke ≤ 500 mm. With stroke > 500 mm, an installation kit HMIXB-RP/FP must be additionally ordered per 500 mm stroke or part thereof.
- 2) Length depends on the stroke of the drive
- 3) Every 500 mm per axis

3-Dimensional gantries

Y modules



Mono system

Toothed belt/spindle axes DGE, linear drives DGC, DGPL

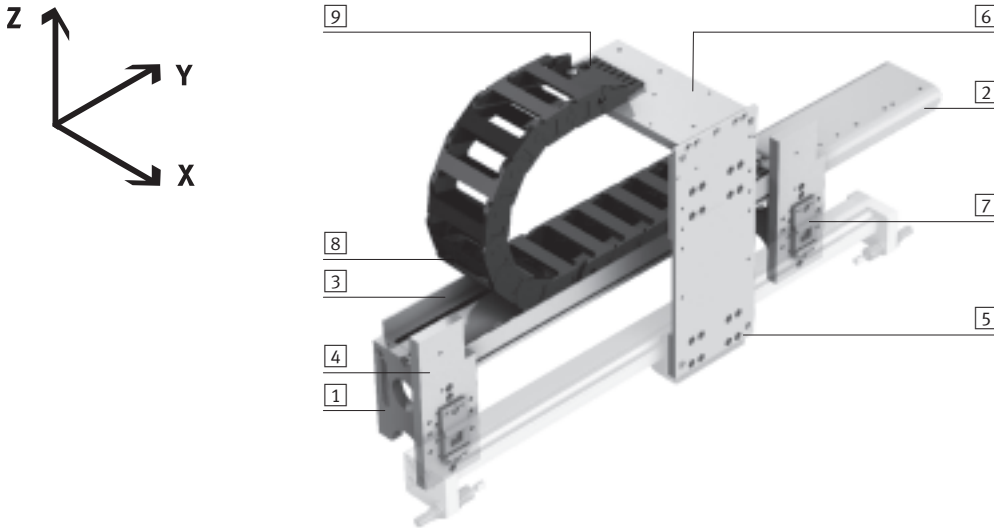

Bill of materials

Type	HMBSY-RP/FP-M25-1	HMBSY-RP/FP-M25-2	HMBSY-RP/FP-M40-1	HMBSY-RP/FP-M40-2		
For drives	DGE-25-SP-KF DGE-25-ZR-KF DGE-25-ZR-RF DGPL-25	DGC-25	DGE-40-SP-KF DGE-40-ZR-KF DGE-40-ZR-RF DGPL-40	DGC-40		
System type	Mono 25		Mono 40			
Item	Quantity	Part No. Type	Part No. Type	Part No. Type	Part No. Type	→ Page
[1]	2	539 657 HMVV-RP/FP	539 657 HMVV-RP/FP	539 657 HMVV-RP/FP	539 657 HMVV-RP/FP	93
[2]	1	539 658 HMIXF-RP/FP	539 658 HMIXF-RP/FP	539 658 HMIXF-RP/FP	539 658 HMIXF-RP/FP	93
[3]	1 ¹⁾	539 379 HMIA-E07	539 379 HMIA-E07	539 379 HMIA-E07	539 379 HMIA-E07	5 / 3.3-139
[4]	2 ³⁾	539 656 HMVM-RP/FP-DL25/40	539 656 HMVM-RP/FP-DL25/40	539 656 HMVM-RP/FP-DL25/40	539 656 HMVM-RP/FP-DL25/40	95
[5]	1	539 368 HMVS-DL25	539 368 HMVS-DL25	539 369 HMVS-DL40	539 369 HMVS-DL40	96
[6]	1	539 659 HMIYF-RF/DL25	539 659 HMIYF-RF/DL25	539 660 HMIYF-RF/DL40	539 660 HMIYF-RF/DL40	5 / 3.3-142
[7]	2 ²⁾	150 736 MUP-18/25	–	–	–	Volume 1
	1 ²⁾	–	531 753 MUC-25	–	531 755 MUC-40	Volume 1
	1 ²⁾	–	–	150 738 MUP-40	–	Volume 1
[8]	1 ¹⁾	IGUS E2 medium 240.07.100.0 and 211 or KABELSCHLEPP MC 0320.80-01 and TS O/n ₇ 2				–
[9]	1	IGUS E2 medium 2070.12.PZB or KABELSCHLEPP MC FA/MA				–

1) Length depends on the stroke of the drive

2) Per basic kit HMVM-RP/FP-DL25/40

3) Quantity with stroke ≤ 500 mm. With stroke > 500 mm, a basic kit HMVM-RP/FP-DL25/40 must be additionally ordered per 500 mm stroke or part thereof.

3-Dimensional gantries

Y modules

Duo system

Toothed belt/spindle axes DGE, linear drives DGC, DGPL

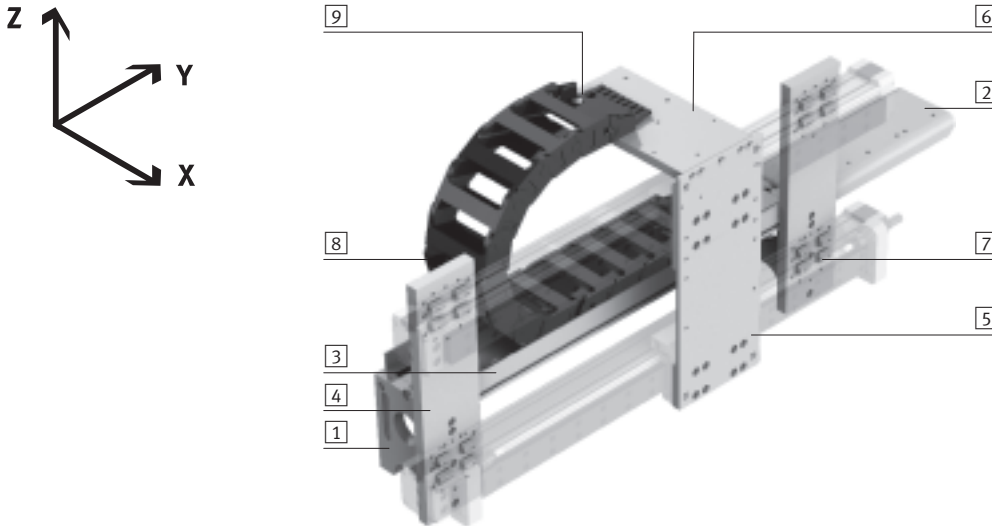

Bill of materials										
Type	HMBSY-RP/FP-D25-1		HMBSY-RP/FP-D25-2		HMBSY-RP/FP-D40-1		HMBSY-RP/FP-D40-2		→ Page	
For drives	DGE-25-SP-KF DGE-25-ZR-KF DGE-25-ZR-RF DGPL-25		DGC-25		DGE-40-SP-KF DGE-40-ZR-KF DGE-40-ZR-RF DGPL-40		DGC-40			
System type	Duo 25				Duo 40					
Item	Quantity	Part No.	Type	Part No.	Type	Part No.	Type	Part No.	Type	
1	2	539 657	HMVV-RP/FP	539 657	HMVV-RP/FP	539 657	HMVV-RP/FP	539 657	HMVV-RP/FP	93
2	1	539 658	HMIXF-RP/FP	539 658	HMIXF-RP/FP	539 658	HMIXF-RP/FP	539 658	HMIXF-RP/FP	93
3	1 ¹⁾	539 379	HMIA-E07	539 379	HMIA-E07	539 379	HMIA-E07	539 379	HMIA-E07	5 / 3.3-139
4	2 ³⁾	539 655	HMVD-RP/FP-DL25/40	539 655	HMVD-RP/FP-DL25/40	539 655	HMVD-RP/FP-DL25/40	539 655	HMVD-RP/FP-DL25/40	95
5	1	539 368	HMVS-DL25	539 368	HMVS-DL25	539 369	HMVS-DL40	539 369	HMVS-DL40	96
6	1	539 659	HMIYF-RF/DL25	539 659	HMIYF-RF/DL25	539 660	HMIYF-RF/DL40	539 660	HMIYF-RF/DL40	5 / 3.3-142
7	4 ²⁾	150 736	MUP-18/25	-	-	-	-	-	-	Volume 1
	2	-	-	531 753	MUC-25	-	-	531 755	MUC-40	Volume 1
8	1 ¹⁾	IGUS E2 medium 240.07.100.0 and 211 or KABELSCHLEPP MC 0320.80-01 and TS O/η ₂							-	
9	1	IGUS E2 medium 2070.12.PZB or KABELSCHLEPP MC FA/MA							-	

1) Length depends on the stroke of the drive

2) Per basic kit HMVD-RP/FP-DL25/40

3) Quantity with stroke ≤ 500 mm. With stroke > 500 mm, a basic kit HMVD-RP/FP-DL25/40 must be additionally ordered per 500 mm stroke or part thereof.

3-Dimensional gantries

Z modules



Mono/Duo system

Mini slides DGSL

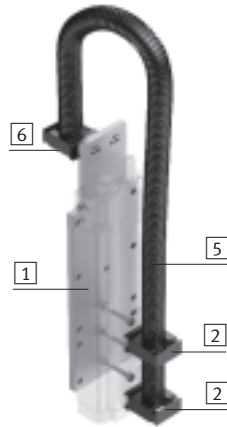

Bill of materials								
Type		HMBSZ-DGSL-7		HMBSZ-DGSL-8				
For drives		DGSL-16		DGSL-20		DGSL-25		
System type		Mono 25		Mono 40 Duo 25		Duo 25		
Item	Quantity	Part No.	Type	Part No.	Type	Part No.	Type	→ Page
[1]	1	539 373	HMVZ-2	539 373	HMVZ-2	539 373	HMVZ-2	97
[2]	1	192 289	MKRS-16,5-B	192 290	MKRS-23-B	192 290	MKRS-23-B	5 / 3.3-131
		548 803	ZBV-M5-7	548 804	ZBV-M5-9	548 804	ZBV-M5-9	
		177 566	MKR-16,5-PG-16	177 567	MKR-23-PG-21	177 567	MKR-23-PG-21	
[5]	1 ¹⁾	192 289	MKRS-16,5-B	192 290	MKRS-23-B	192 290	MKRS-23-B	5 / 3.3-124
[6]	1	192 289	MKRS-16,5-B	192 290	MKRS-23-B	192 290	MKRS-23-B	5 / 3.3-131

1) Length depends on the stroke of the drive

3-Dimensional gantries

Z modules

Mono/Duo system

Mini slides SLT

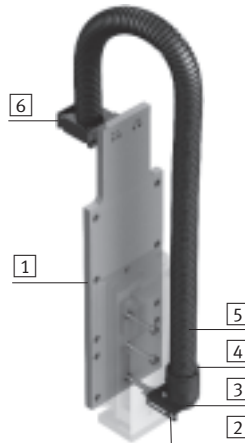
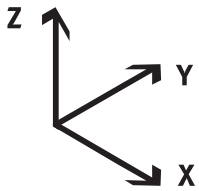

Bill of materials							
Type		HMBSZ-SLT-7					
For drives		SLT-16		SLT-20		SLT-25	
System type		Mono 25		Mono 40 Duo 25		Duo 25	
Item	Quantity	Part No.	Type	Part No.	Type	Part No.	Type
1	1	539 373	HMVZ-2	539 373	HMVZ-2	539 373	HMVZ-2
2	1	193 124	HMZAS-PG-21	193 124	HMZAS-PG-21	193 124	HMZAS-PG-21
3	1	177 599	MKM-PG-21	177 599	MKM-PG-21	177 599	MKM-PG-21
4	1	177 572	MKRV-23-PG-21	177 572	MKRV-23-PG-21	177 572	MKRV-23-PG-21
5	1 ¹⁾	177 567	MKR-23-PG-21	177 567	MKR-23-PG-21	177 567	MKR-23-PG-21
6	1	192 290	MKRS-23-B	192 290	MKRS-23-B	192 290	MKRS-23-B

1) Length depends on the stroke of the drive

3-Dimensional gantries

Z modules



Mono/Duo system

Linear modules HMPL

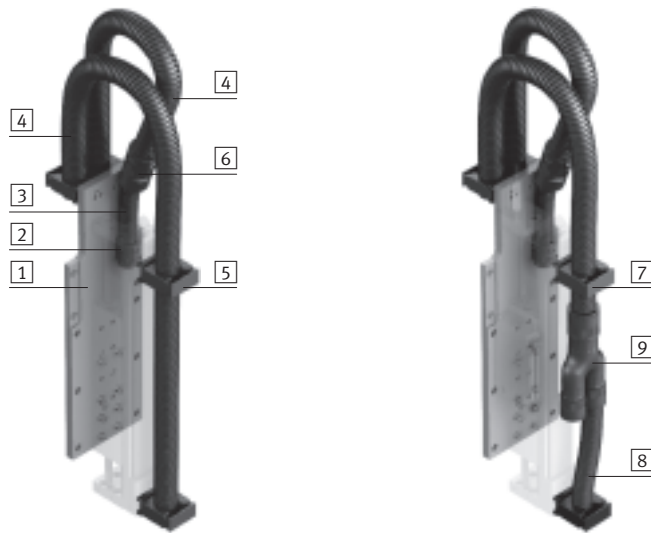
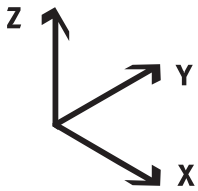

Bill of materials

Type		HMBSZ-HMPL-5		HMBSZ-HMPL-6		→ Page	
For drives		HMPL-16	HMPL-20	HMPL-16	HMPL-20		
		without intermediate position		with intermediate position			
System type		Mono 25	Mono 40 Duo 25	Mono 25	Mono 40 Duo 25		
Item	Quantity	Part No.	Type	Part No.	Type	Part No.	Type
[1]	1	539 375	HMVZ-4	539 375	HMVZ-4	539 375	HMVZ-4
[2]	1	177 571	MKRV-16,5-PG-16	177 571	MKRV-16,5-PG-16	177 571	MKRV-16,5-PG-16
[3]	1 ¹⁾	177 566	MKR-16,5-PG-16	177 566	MKR-16,5-PG-16	177 566	MKR-16,5-PG-16
[4]	1 ²⁾	177 567	MKR-23-PG-21	177 567	MKR-23-PG-21	177 567	MKR-23-PG-21
[5]	4 ³⁾	192 290	MKRS-23-B	192 290	MKRS-23-B	-	-
[6]	1	194 321	MKRT-23-16,5	194 321	MKRT-23-16,5	194 321	MKRT-23-16,5
[7]	3 ³⁾	-	-	-	-	192 290	MKRS-23-B
[8]	1	-	-	-	-	192 289	MKRS-16,5-B
[9]	1	-	-	-	-	193 946	MKY-PG-21-2PG-16

1) Length 200 mm

2) Length depends on the stroke of the drive, 2 conduits are required with an intermediate position.

3) In order to be able to mount the retaining clip MKRS, a clamping component (2x code J) must be selected as an accessory in the order for the linear module HMPL.

3-Dimensional gantries

Z modules

Mono/Duo system
Linear modules HMP

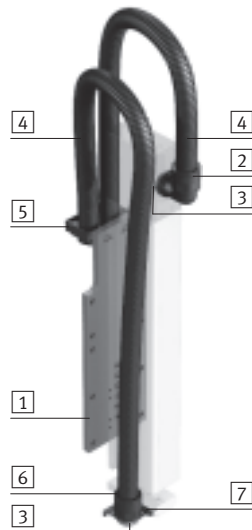
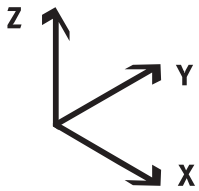

Bill of materials								
Type	HMBSZ-HMP-4		HMBSZ-HMP-5		HMBSZ-HMP-6		→ Page	
For drives	HMP-16		HMP-20		HMP-25			
System type	Mono 40 Duo 25		Duo 25		Duo 40			
Item	Quantity	Part No.	Type	Part No.	Type	Part No.	Type	
1	1	539 374	HMVZ-3	539 374	HMVZ-3	539 377	HMVZ-6	97
2	1	177 577	MKRL-23-PG-21	177 578	MKRL-29-PG-29	177 578	MKRL-29-PG-29	5 / 3.3-127
3	2	177 599	MKM-PG-21	177 600	MKM-PG-29	177 600	MKM-PG-29	5 / 3.3-131
4	1 ¹⁾	177 567	MKR-23-PG-21	177 568	MKR-29-PG-29	177 568	MKR-29-PG-29	5 / 3.3-124
5	2	192 290	MKRS-23-B	192 291	MKRS-29-B	192 291	MKRS-29-B	5 / 3.3-131
6	1	177 572	MKRV-23-PG-21	177 573	MKRV-29-PG-29	177 573	MKRV-29-PG-29	5 / 3.3-126
7	1	193 124	HMZAS-PG-21	177 603	HMZAS-PG-29	177 603	HMZAS-PG-29	5 / 3.3-132

1) Length depends on the stroke of the drive

3-Dimensional gantries

Z modules

Mono/Duo system

Cantilever axes DGEA

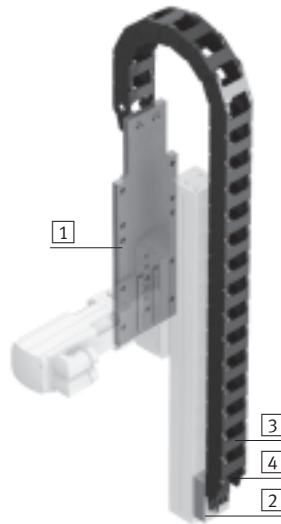
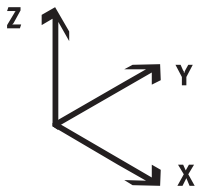

Bill of materials

Type	HMBSZ-DGEA-1	HMBSZ-DGEA-2	HMBSZ-DGEA-3		
For drives	DGEA-18	DGEA-25	DGEA-25		
System type	Mono 25 Mono 40 Duo 25	Duo 25	Duo 40		
Item	Quantity	Part No. Type	Part No. Type	Part No. Type	→ Page
[1]	1	539 374 HMVZ-3	539 375 HMVZ-4	539 377 HMVZ-6	97
[2]	1	539 370 HMIZF-E03-DA18	539 371 HMIZF-E03-DA25	539 371 HMIZF-E03-DA25	5 / 3.3-138
[3]	1 ¹⁾	IGUS E2 medium 240.03.075.0 and 211 or KABELSCHLEPP MC 0320.40-01-77 and TS 0/n _T 2			-
[4]	1	IGUS E2 medium 2030.12.PZB or KABELSCHLEPP MC FA/MA			-

1) Length depends on the stroke of the drive

3-Dimensional gantries

Z modules

Mono/Duo system
Toothed belt axes DGE

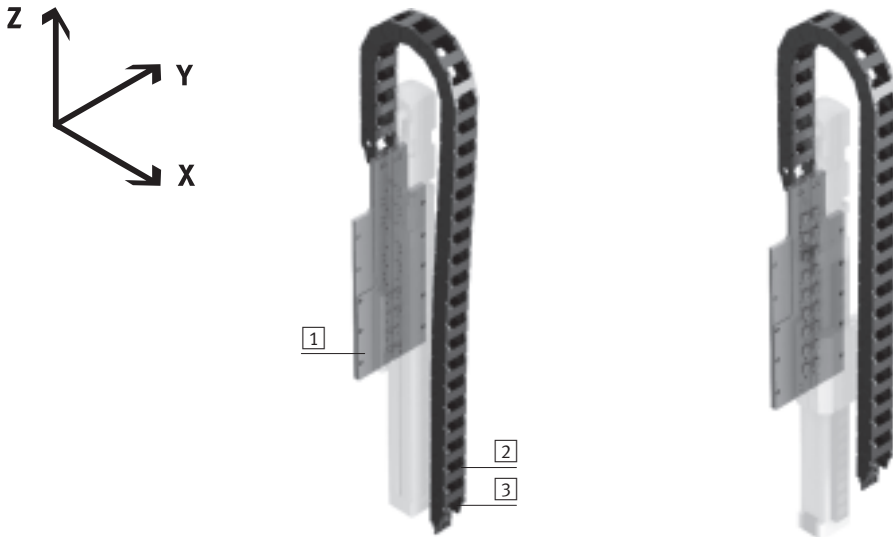

Bill of materials									
Type	HMBSZ-DGE-1		HMBSZ-DGE-2		HMBSZ-DGE-3				
For drives	DGE-25-SP		DGE-40-SP		DGE-40-SP				
System type	Mono 40 Duo 25		Duo 25		Duo 40				
Item	Quantity	Part No.	Type	Part No.	Type	Part No.	Type	→ Page	
1	1	539 374	HMVZ-3	539 375	HMVZ-4	539 377	HMVZ-6	97	
2	1 ¹⁾	IGUS E2 medium 240.03.075.0 and 211 or KABELSCHLEPP MC 0320.40-01-77 and TS O/nT2							-
3	1	IGUS E2 medium 2030.12.PZB or KABELSCHLEPP MC FA/MA							-

1) Length depends on the stroke of the drive

3-Dimensional gantries

System example



Combination with toothed-belt axis DGE-RF/linear drive DGC/mini-slide SLT

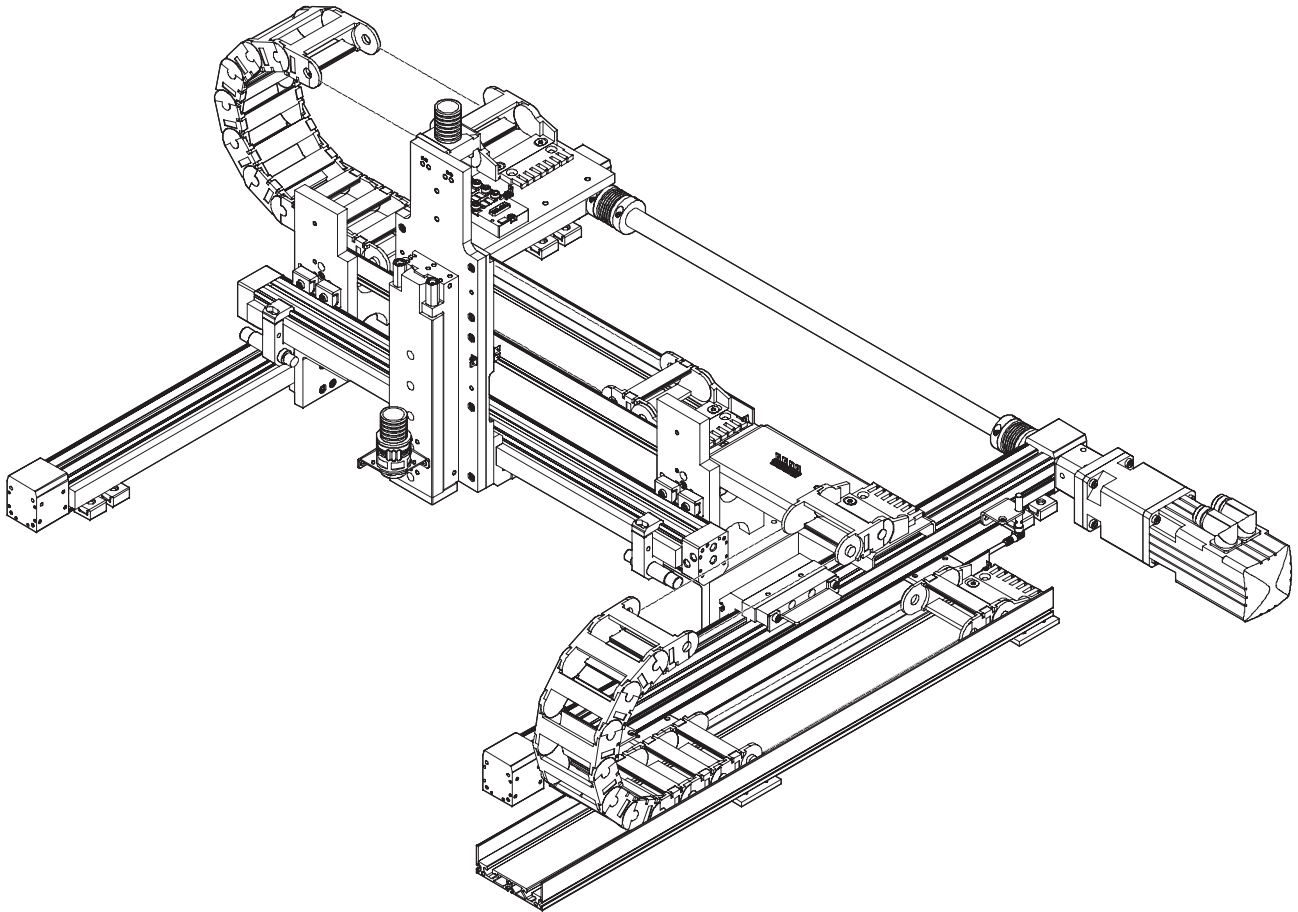

System components
Multi-axis modular system

3.3



- Modular
- Functional
- Versatile

Connectors

Key features



System components
Multi-axis modular system

3.3

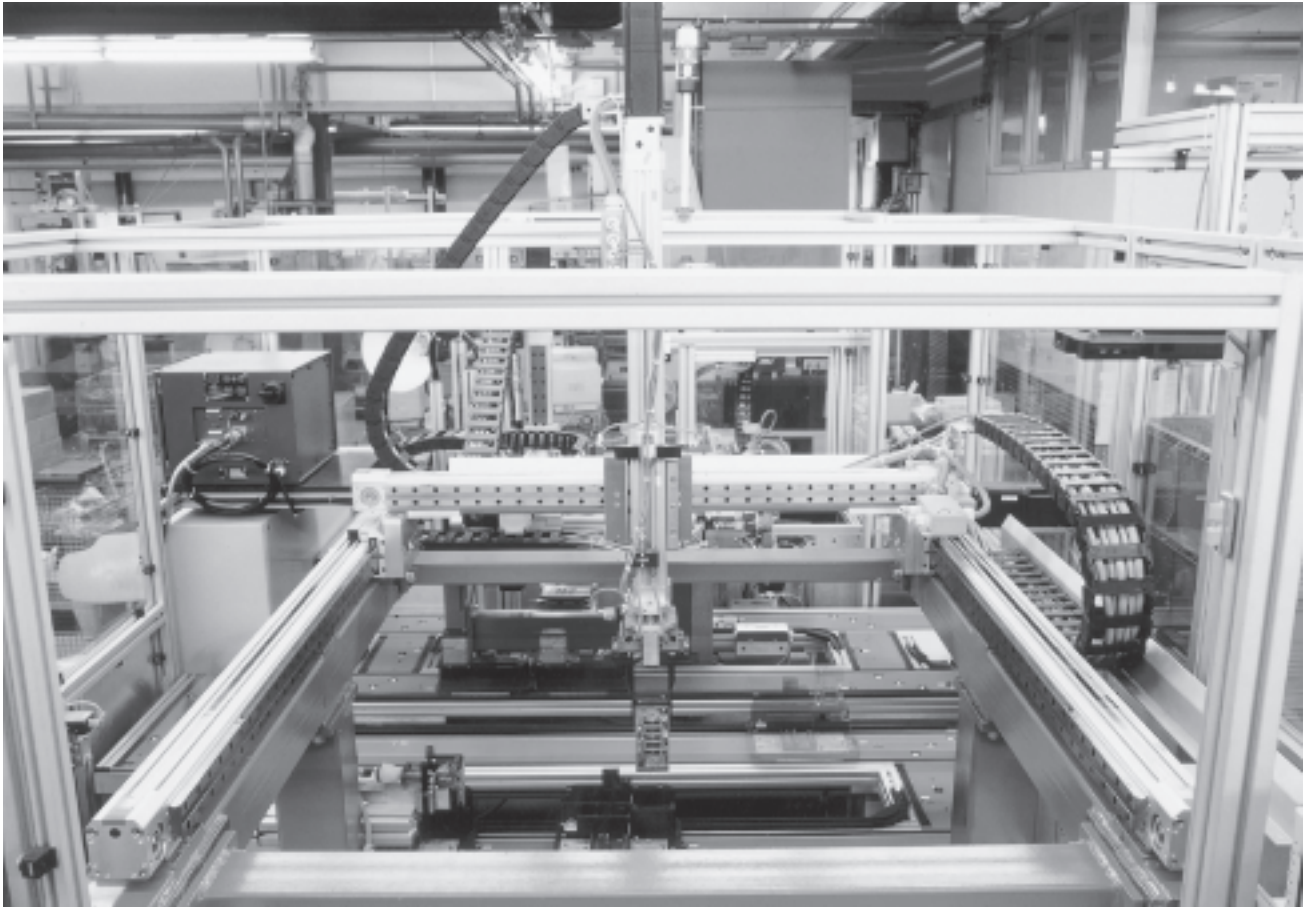

Connecting kits

Basic kit

Kit that serves as the basis for the individual modules in a multi-axis system and as the interface to the surrounding machines.

Adapter kit

Kit for connecting drives. Direct mounting or mounting via slot nuts.

Connecting kit

For connecting drives and basic components.

Reinforcing kit

Primarily used to reinforce an existing connection. Also used to mount the base profile for power cables.

Mounting kit

For mounting accessories such as controllers on multi-axis systems.

Connectors

Key features

Linear gantry

- 1 Components for combining basic axes (basic kit)
- 2 Components for connecting the drives (adapter kit)
- 3 Components for mounting the drives along the Z-axis in gantry designs

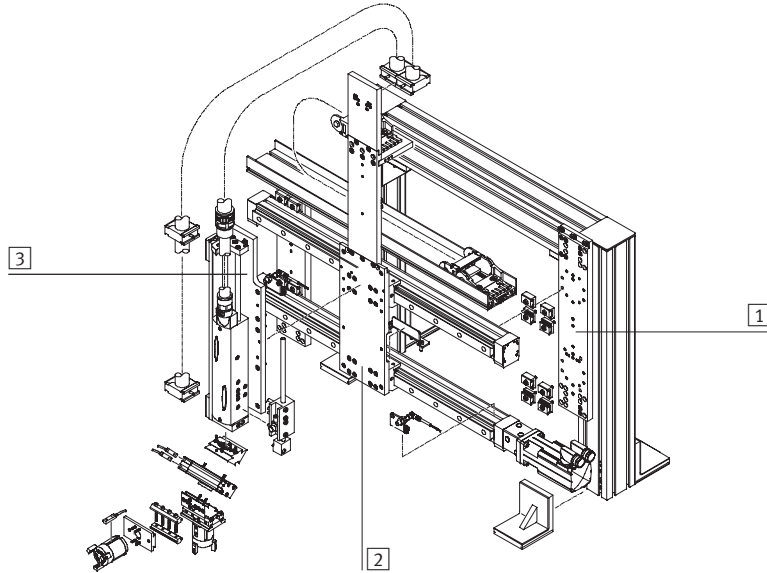

3-Dimensional gantry



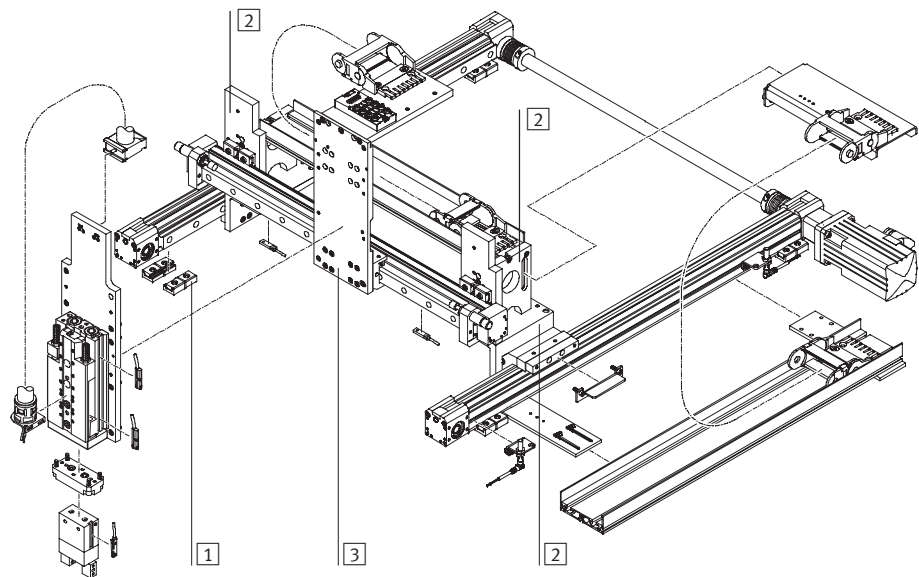

- 1 Components for combining basic axes
- 2 Components for lateral mounting of an axis (adapter kit, reinforcing kit, basic kit)
- 3 Components for mounting the drives along the Z-axis in gantry designs







Connectors

Product range overview

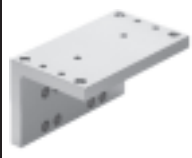







Version	Brief description	→ Page
Reinforcing kit HMBK-DB		
	<ul style="list-style-type: none"> ■ For pick & place ■ For direct mounting of linear modules HMP and HMPL 	88
Components kit HMBK-ND		
	<ul style="list-style-type: none"> ■ For pick & place ■ For direct mounting of linear modules HMP 	88
Connecting kit HMBK-WS		
	<ul style="list-style-type: none"> ■ For pick & place ■ For dovetail mounting of linear modules HMP and HMPL and mini slides SLT 	89
Connecting adapter HMY		
	<ul style="list-style-type: none"> ■ For pick & place ■ For connecting basic components and drives ■ Fastening material is included in delivery 	90

Version	Brief description	→ Page
Adapter kit HMY-DL		
	<ul style="list-style-type: none"> ■ For 3-dimensional gantries ■ For connecting X-axes and Y-axes ■ Mounting interface for reinforcing kit HMYV and basic kit HMYM ■ Fastening material is included in delivery 	91
Adapter kit HMY-S-RF		
	<ul style="list-style-type: none"> ■ For 3-dimensional gantries ■ For connecting X-axes and Y-axes ■ For toothed belt axis DGE-RF with roller guide ■ Mounting interface for reinforcing kit HMYV and basic kit HMYM ■ Fastening material is included in delivery 	92
Reinforcing kit HMYV-RP/FP		
	<ul style="list-style-type: none"> ■ For 3-dimensional gantries ■ Mounting interface for basic kit HMYM/HMYD, installation components, etc. ■ Fastening material is included in delivery 	93
Basic kit HMYM-LP, HMYD-LP		
	<ul style="list-style-type: none"> ■ For linear gantries ■ For Y-axis ■ For Mono and Duo systems ■ Mounting interface for profiles, drives and displacement encoders ■ Fastening material is included in delivery 	94

Connectors

Product range overview

Version	Brief description	→ Page	Version	Brief description	→ Page
Basic kit HMVM-RP/FP, HMVD-RP/FP			Connecting plate HMVO-RF		
	<ul style="list-style-type: none"> ■ For 3-dimensional gantries ■ For Y-axis ■ For Mono and Duo systems ■ Mounting interface for drives ■ Fastening material is included in delivery 	95		<ul style="list-style-type: none"> ■ For linear gantries ■ Compensating component for toothed belt axis DGE-RF for compensating the difference in height in comparison with the axes DGE-ZR-KF and DGE-SP-KF 	98
Adapter kit HMVS-DL			Connecting plate HMVO-POT		
	<ul style="list-style-type: none"> ■ For linear and 3-dimensional gantries ■ For Mono and Duo systems ■ Mounting interface for basic kit HMVZ ■ Fastening material and earthing kits are included in delivery 	96		<ul style="list-style-type: none"> ■ For linear gantries ■ Compensating component for displacement encoder MLO-POT-TLF for compensating the difference in height in comparison with the linear drive DGPL with MUP 	98
Basic kit HMVZ			Mounting kit HMVW-SPC		
	<ul style="list-style-type: none"> ■ For linear and 3-dimensional gantries ■ For Z-axis ■ For Mono and Duo systems ■ Mounting interface for drives, installation components, etc. ■ Fastening material and earthing kits are included in delivery 	97		<ul style="list-style-type: none"> ■ For mounting the axis interface on the end cap of the drive ■ Fastening material is included in delivery 	99

Connectors

Technical data



Components kit HMBK-DB

- For pick & place

- For direct mounting of linear modules HMP and HMPL

Material:
Steel
Free of copper, PTFE and silicone

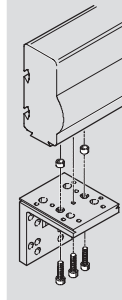

Technical data and ordering codes			
CRC ¹⁾	Weight [g]	Part No.	Type
2	15	175 973	HMBK-DB

1) Corrosion resistance class 2 according to Festo standard 940 070
Components requiring moderate corrosion resistance. Externally visible parts with primarily decorative surface requirements which are in direct contact with a normal industrial environment or media such as coolants or lubricating agents.

Components kit HMBK-ND

- For pick & place

- For direct mounting of linear modules HMP

Material: Steel
Tempered steel, non-alloyed
Free of copper, PTFE and silicone

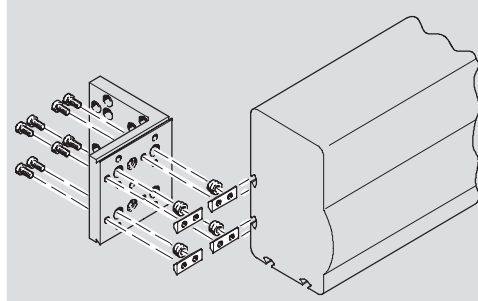

Technical data and ordering codes			
CRC ¹⁾	Weight [g]	Part No.	Type
2	62	175 970	HMBK-ND

1) Corrosion resistance class 2 according to Festo standard 940 070
Components requiring moderate corrosion resistance. Externally visible parts with primarily decorative surface requirements which are in direct contact with a normal industrial environment or media such as coolants or lubricating agents.

Connectors

Technical data



Connecting kit HMBK-WS



- For pick & place

- For dovetail mounting of linear modules HMP and HMPL and mini slides SLT

Material:
Anodised aluminium
Free of copper, PTFE and silicone

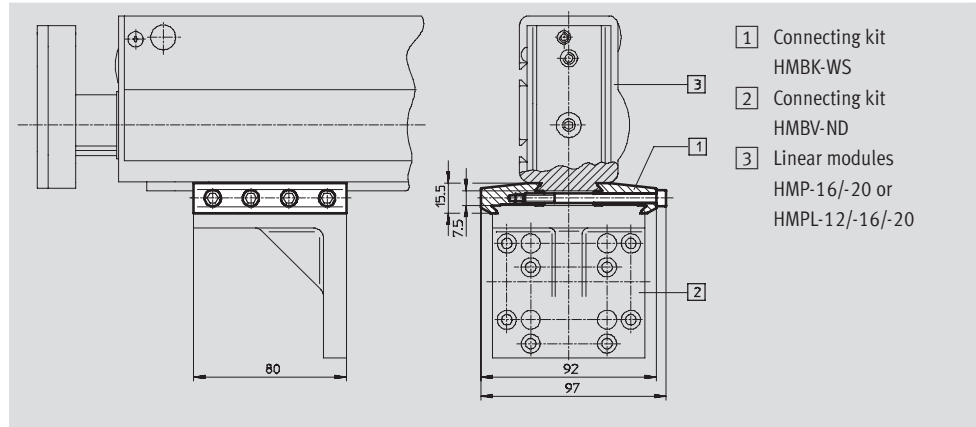

Technical data and ordering codes

CRC ¹⁾	Weight [g]	Part No.	Type
2	453	175 975	HMBK-WS

1) Corrosion resistance class 2 according to Festo standard 940 070
Components requiring moderate corrosion resistance. Externally visible parts with primarily decorative surface requirements which are in direct contact with a normal industrial environment or media such as coolants or lubricating agents.

Connectors

Technical data



Connecting adapter HMVY



- For pick & place

- For connecting basic components and drives
- Fastening material is included in delivery

Material:
Anodised aluminium
Free of copper, PTFE and silicone

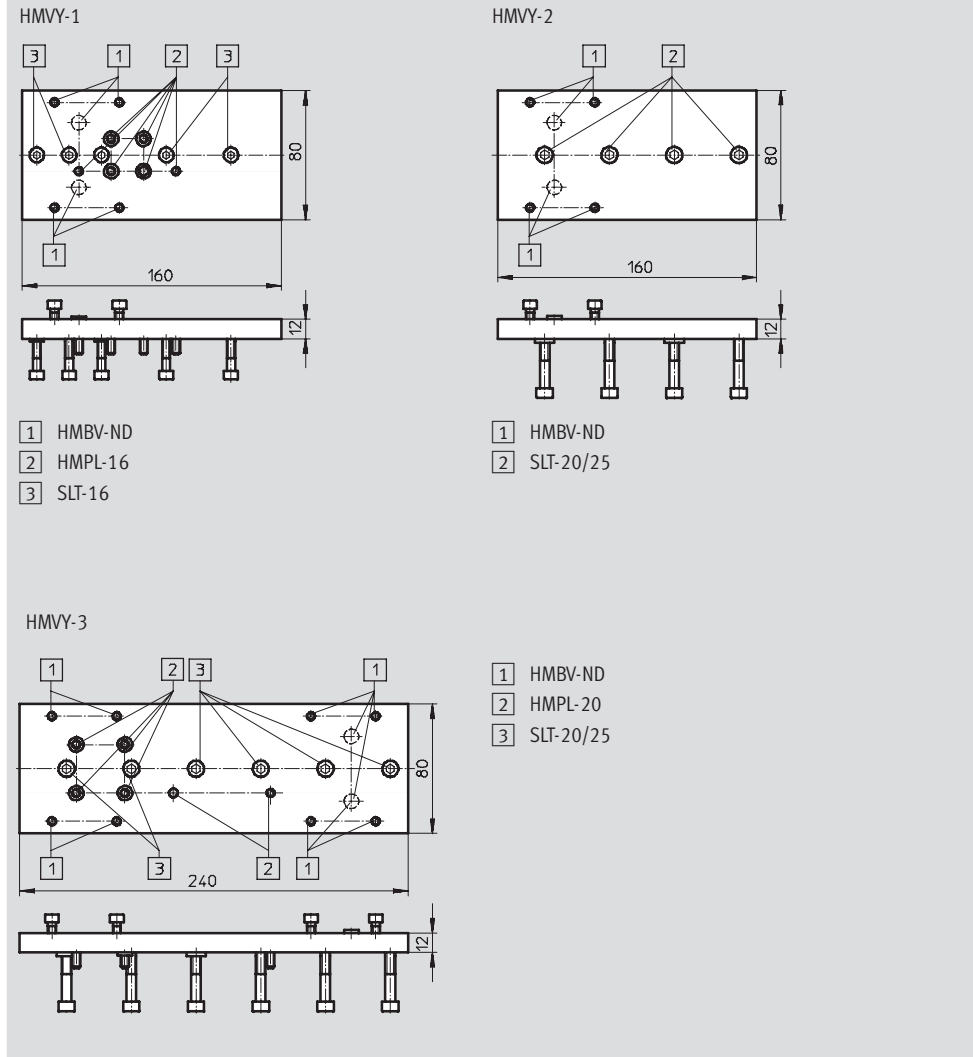

Technical data and ordering codes			
CRC ¹⁾	Weight	Part No.	Type
	[g]		
2	410	539 968	HMVY-1
	420	539 969	HMVY-2
	620	539 970	HMVY-3

1) Corrosion resistance class 2 according to Festo standard 940 070
Components requiring moderate corrosion resistance. Externally visible parts with primarily decorative surface requirements which are in direct contact with a normal industrial environment or media such as coolants or lubricating agents.

Connectors

Technical data



Adapter kit HMVW-DL

- For 3-dimensional gantries
- For connecting X-axes and Y-axes

- Mounting interface for reinforcing kit HMVV and basic kit HMVM
- Fastening material is included in delivery

Material:
Anodised aluminium
Free of copper, PTFE and silicone



HMVW-DL25

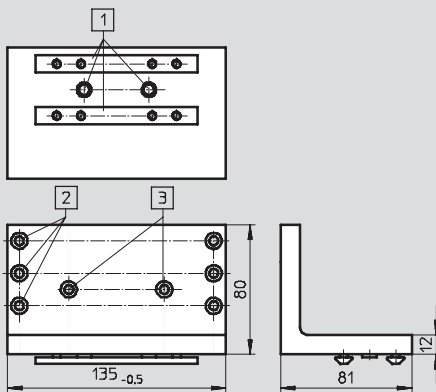

- 1 DGE-25-ZR-KF
- 2 HMVM-RP/FP-DL25/40
HMVD-RP/FP-DL25/40
- 3 HMVV-RP/FP

HMVW-DL40

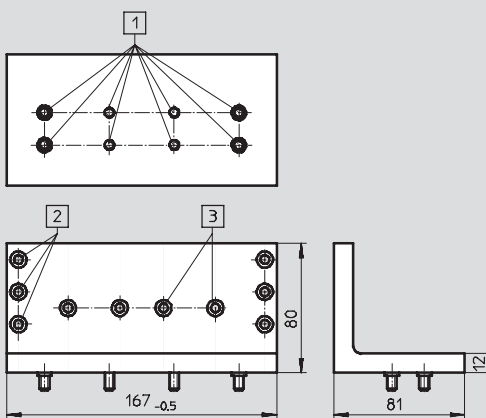

- 1 DGE-40-ZR-KF
- 2 HMVM-RP/FP-DL25/40
HMVD-RP/FP-DL25/40
- 3 HMVV-RP/FP

Technical data and ordering codes

CRC ¹⁾	Weight	Part No.	Type
	[g]		
2	640	539 651	HMVW-DL25
	800	540 325	HMVW-DL40

1) Corrosion resistance class 2 according to Festo standard 940 070
Components requiring moderate corrosion resistance. Externally visible parts with primarily decorative surface requirements which are in direct contact with a normal industrial environment or media such as coolants or lubricating agents.

Connectors

Technical data



Adapter kit HMVS-RF

- For 3-dimensional gantries
- For connecting X-axes and Y-axes
- For toothed belt axis DGE-RF with roller guide
- Mounting interface for reinforcing kit HMVV and basic kit HMVM
- Fastening material is included in delivery

Material:
Anodised aluminium
Free of copper, PTFE and silicone



HMVS-RF-25

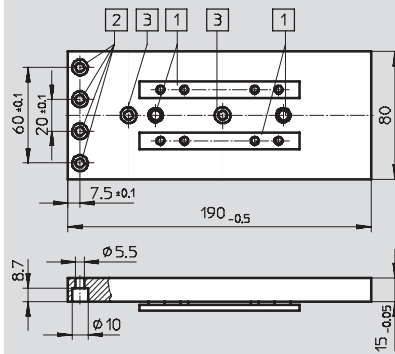

- 1 DGE-25-ZR-RF
- 2 HMVM-RP/FP-DL25/40
HMVD-RP/FP-DL25/40
- 3 HMVV-RP/FP

HMVS-RF-40

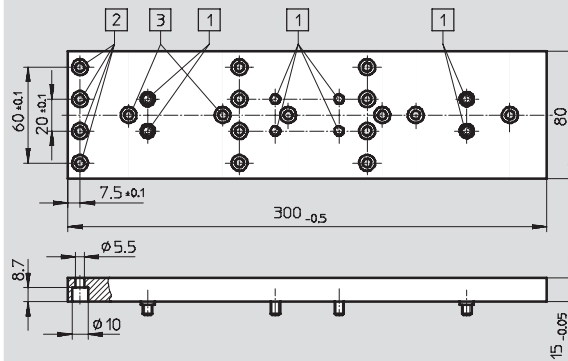

- 1 DGE-40-ZR-RF
- 2 HMVM-RP/FP-DL25/40
HMVD-RP/FP-DL25/40
- 3 HMVV-RP/FP

Technical data and ordering codes

CRC ¹⁾	Weight	Part No.	Type
	[g]		
2	600	539 652	HMVS-RF25
	930	539 653	HMVS-RF40

1) Corrosion resistance class 2 according to Festo standard 940 070
Components requiring moderate corrosion resistance. Externally visible parts with primarily decorative surface requirements which are in direct contact with a normal industrial environment or media such as coolants or lubricating agents.

Connectors

Technical data



Reinforcing kit HMVV-RP/FP

- For 3-dimensional gantries

- Mounting interface for basic kit HMVM/HMVD, installation components, etc.
- Fastening material is included in delivery

Material:
Anodised aluminium
Free of copper, PTFE and silicone

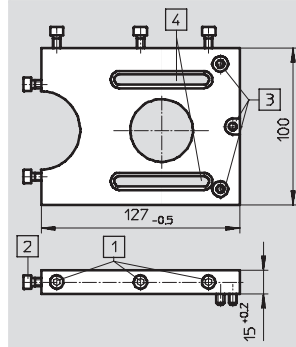

- 1 HMVM-RP/FP-DL25/40
HMVD-RP/FP-DL25/40
- 2 HMVS-RF25/40
HMVW-DL25/40
- 3 HMIA-E07
- 4 HMIXF-RP/FP

Technical data and ordering codes			
CRC ¹⁾	Weight	Part No.	Type
	[g]		
2	400	539 657	HMVV-RP/FP

1) Corrosion resistance class 2 according to Festo standard 940 070
Components requiring moderate corrosion resistance. Externally visible parts with primarily decorative surface requirements which are in direct contact with a normal industrial environment or media such as coolants or lubricating agents.

Connectors

Technical data



Basic kit
HMVM-LP
HMVD-LP

- For linear gantries
- For Y-axis
- For Mono and Duo systems
- Mounting interface for profiles, drives and displacement encoders
- Fastening material is included in delivery

Material:
Anodised aluminium
Free of copper, PTFE and silicone

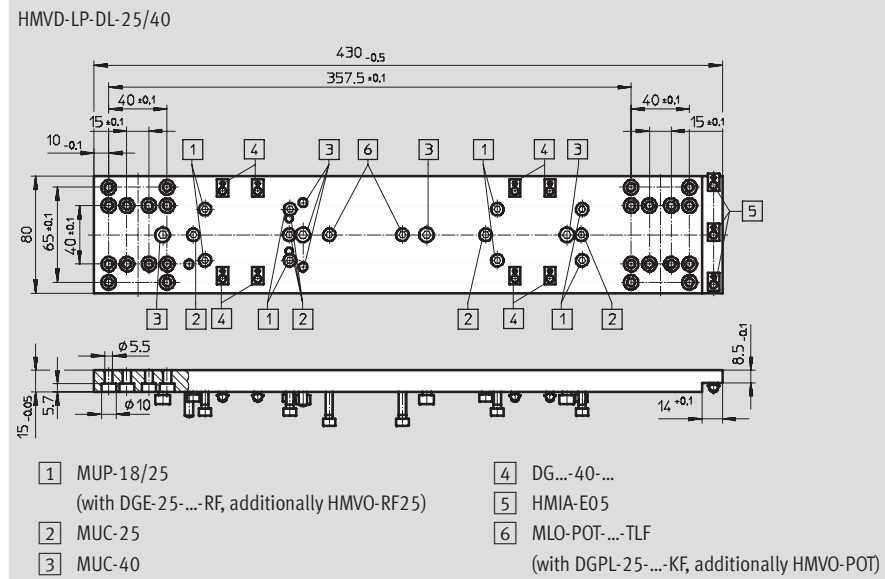
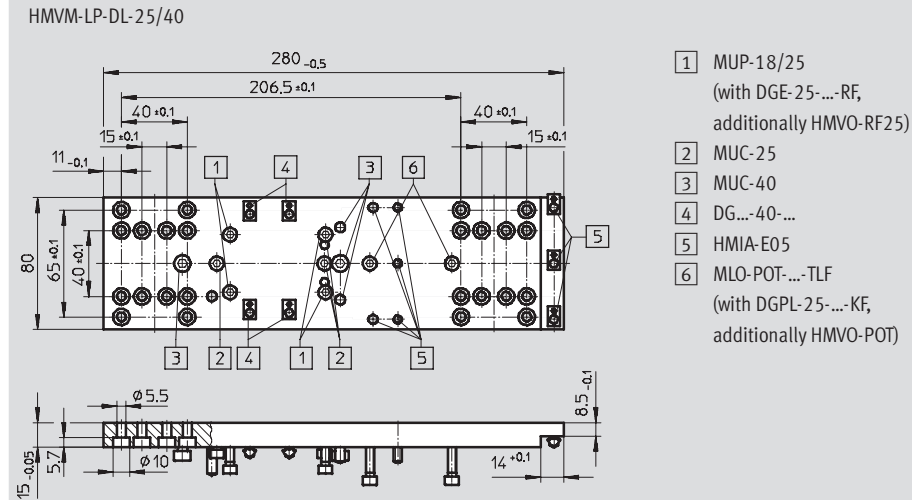

Technical data and ordering codes				
For system type	CRC ¹⁾	Weight [g]	Part No.	Type
Mono	2	830	539 972	HMVM-LP-DL-25/40
Duo		1320	539 971	HMVD-LP-DL-25/40

1) Corrosion resistance class 2 according to Festo standard 940 070
Components requiring moderate corrosion resistance. Externally visible parts with primarily decorative surface requirements which are in direct contact with a normal industrial environment or media such as coolants or lubricating agents.

Connectors

Technical data



Basic kit
HMVM-RP/FP
HMVD-RP/FP



- For 3-dimensional gantries
- For Y-axis
- For Mono and Duo systems
- Mounting interface for drives
- Fastening material is included in delivery

Material:
 Anodised aluminium
 Free of copper, PTFE and silicone

HMVM-RP/FP-DL-25/40

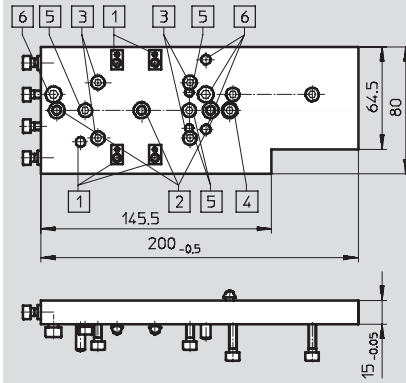

- 1 DG...-40
- 2 HMVV-RP/FP
- 3 MUP-18/25
- 4 HMIA-E07
- 5 MUC-25
- 6 MUC-40

HMVD-RP/FP-DL-25/40

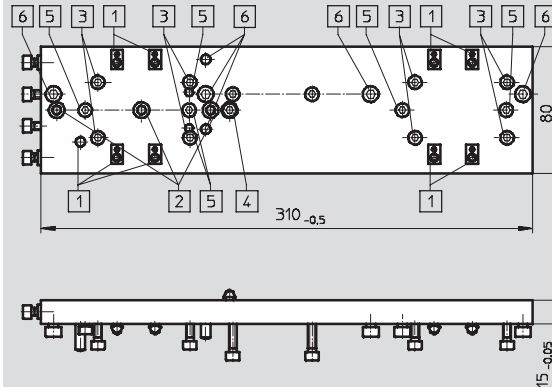

- 1 DG...-40
- 2 HMVV-RP/FP
- 3 MUP-18/25
- 4 HMIA-E07
- 5 MUC-25
- 6 MUC-40

Technical data and ordering codes

For system type	CRC ¹⁾	Weight	Part No.	Type
		[g]		
Mono	2	600	539 656	HMVM-RP/FP-DL-25/40
Duo		1000	539 655	HMVD-RP/FP-DL-25/40

1) Corrosion resistance class 2 according to Festo standard 940 070
 Components requiring moderate corrosion resistance. Externally visible parts with primarily decorative surface requirements which are in direct contact with a normal industrial environment or media such as coolants or lubricating agents.

System components
 Multi-axis modular system
3.3

Connectors

Technical data



Adapter kit HMVS-DL

- For linear and 3-dimensional gantries
- For Mono and Duo systems
- Mounting interface for basic kit HMVZ
- Fastening material and earthing kits are included in delivery

Material:
Anodised aluminium
Free of copper, PTFE and silicone

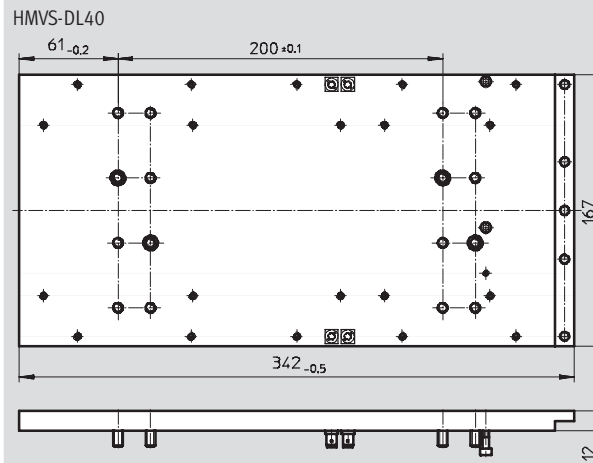
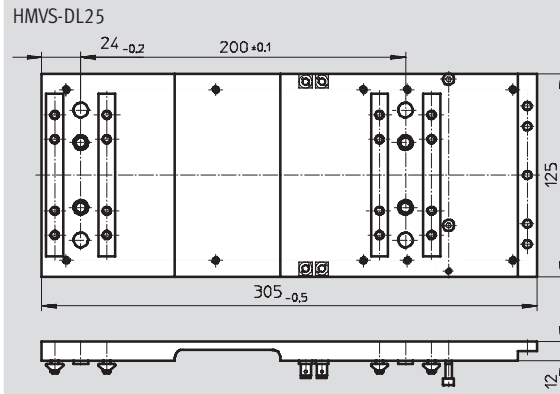

Technical data and ordering codes

CRC ¹⁾	Weight	Part No.	Type
	[g]		
2	1050	539 368	HMVS-DL25
	1800	539 369	HMVS-DL40

1) Corrosion resistance class 2 according to Festo standard 940 070
Components requiring moderate corrosion resistance. Externally visible parts with primarily decorative surface requirements which are in direct contact with a normal industrial environment or media such as coolants or lubricating agents.

Connectors

Technical data



Basic kit HMVZ



- For linear and 3-dimensional gantries
- For Z-axis

- For Mono and Duo systems
- Mounting interface for drives, installation components, etc.

Material:
Anodised aluminium
Free of copper, PTFE and silicone

- Fastening material and earthing kits are included in delivery

- 1 HMVS-DL-25
- 2 HMVS-DL-40
- 3 Universal interface
- 4 SLT-16
- 5 SLT-20/25
- 6 HMID-LP
- 7 DGE-25/DGEA-18
- 8 HMP-16/20
- 9 HMPL-16/20
- 10 HMPL-16/20, HMPL-...-KP
- 11 DGE-40/DGEA-25
- 12 DGE-40 (profile)
- 13 HMP-25
- 14 Protective trunking
- 15 Protective trunking
- 16 MKRS-16,5/23/29-B

HMVZ-...

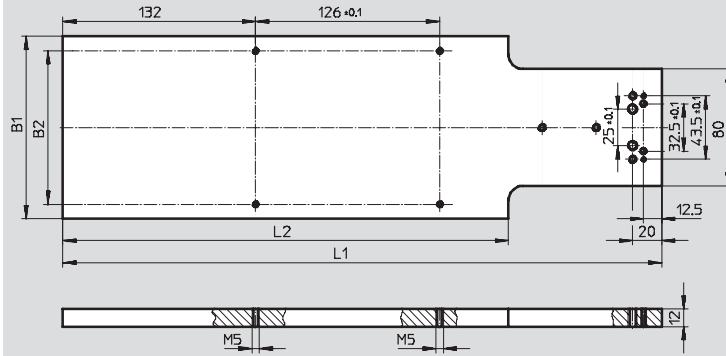

HMVZ-1

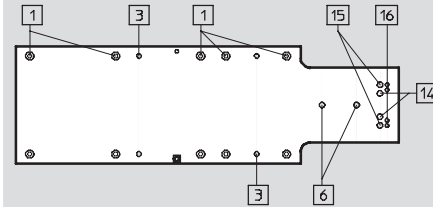

HMVZ-2

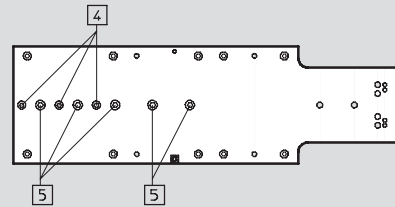

HMVZ-3

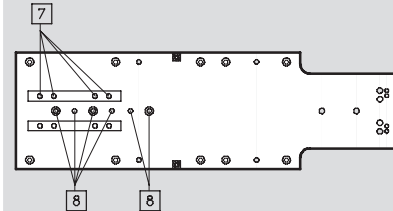

HMVZ-4

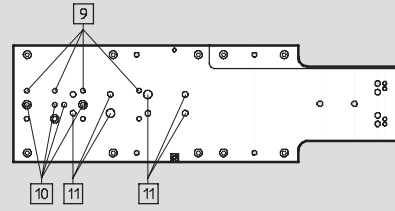

HMVZ-5

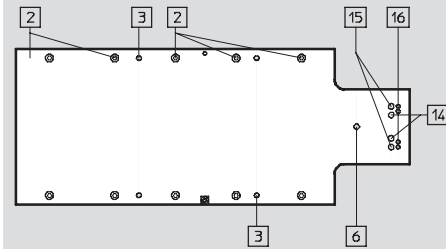

HMVZ-6

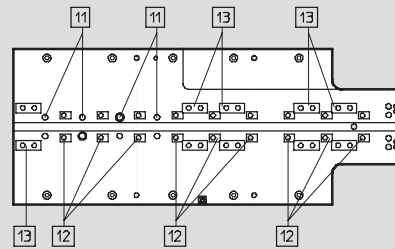

Dimensions, technical data and ordering data

B1	B2	L1	L2	CRC ¹⁾	Weight [g]	Part No.	Type
	± 0.1	- 0.5	- 0.5	2	1520	539 372	HMVZ-1
125	105	410	305		1510	539 373	HMVZ-2
					1490	539 374	HMVZ-3
167	155	422	342		1450	539 375	HMVZ-4
					2080	539 376	HMVZ-5
					1900	539 377	HMVZ-6

1) Corrosion resistance class 2 according to Festo standard 940 070
Components requiring moderate corrosion resistance. Externally visible parts with primarily decorative surface requirements which are in direct contact with a normal industrial environment or media such as coolants or lubricating agents.

Connectors

Technical data



Connecting plate HMVO-RF

- For linear gantries
- Compensating component for toothed belt axis DGE-RF for compensating the difference in height in comparison with the axes DGE-ZR-KF and DGE-SP-KF

Material:
Anodised aluminium
Free of copper, PTFE and silicone

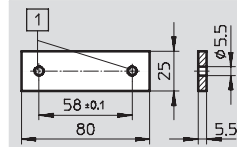
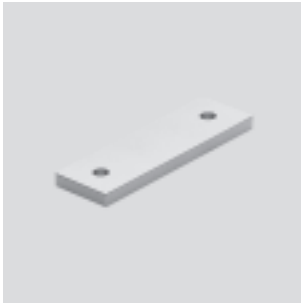

1) HMVM-LP-DL25/40
HMVD-LP-DL25/40
MUP-18/25

Technical data and ordering codes			
CRC ¹⁾	Weight	Part No.	Type
	[g]		
2	30	539 362	HMVO-RF25

1) Corrosion resistance class 2 according to Festo standard 940 070
Components requiring moderate corrosion resistance. Externally visible parts with primarily decorative surface requirements which are in direct contact with a normal industrial environment or media such as coolants or lubricating agents.

Connecting plate HMVO-POT

- For linear gantries
- Compensating component for displacement encoder MLO-POT-TLF for compensating the difference in height in comparison with the linear drive DGPL with MUP

Material:
Anodised aluminium
Free of copper, PTFE and silicone

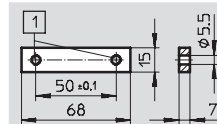

1) HMVM-LP-DL25/40
HMVD-LP-DL25/40
MLO-POT-TLF

Technical data and ordering codes			
CRC ¹⁾	Weight	Part No.	Type
	[g]		
2	20	539 973	HMVO-POT

1) Corrosion resistance class 2 according to Festo standard 940 070
Components requiring moderate corrosion resistance. Externally visible parts with primarily decorative surface requirements which are in direct contact with a normal industrial environment or media such as coolants or lubricating agents.

Connectors

Technical data

Mounting kit HMVW-SPC

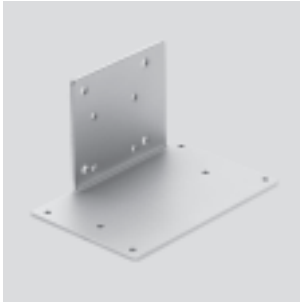

- For mounting the axis interface on the end cap of the drive
- Fastening material is included in delivery

Material:
Galvanised steel
Free of copper, PTFE and silicone

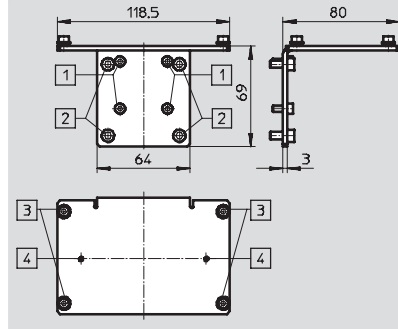

- 1 DG...-25
- 2 DG...-40
- 3 SPC11-MTS-AIF-SA
- 4 SPC-AIF-MTS

Technical data and ordering codes			
CRC ¹⁾	Weight	Part No.	Type
	[g]		
2	310	539 367	HMVW-SPC

1) Corrosion resistance class 2 according to Festo standard 940 070
Components requiring moderate corrosion resistance. Externally visible parts with primarily decorative surface requirements which are in direct contact with a normal industrial environment or media such as coolants or lubricating agents.

