

- Reliable and accurate
- Highly flexible
- Versatile

Precision parallel grippers HGPP

Key features

FESTO

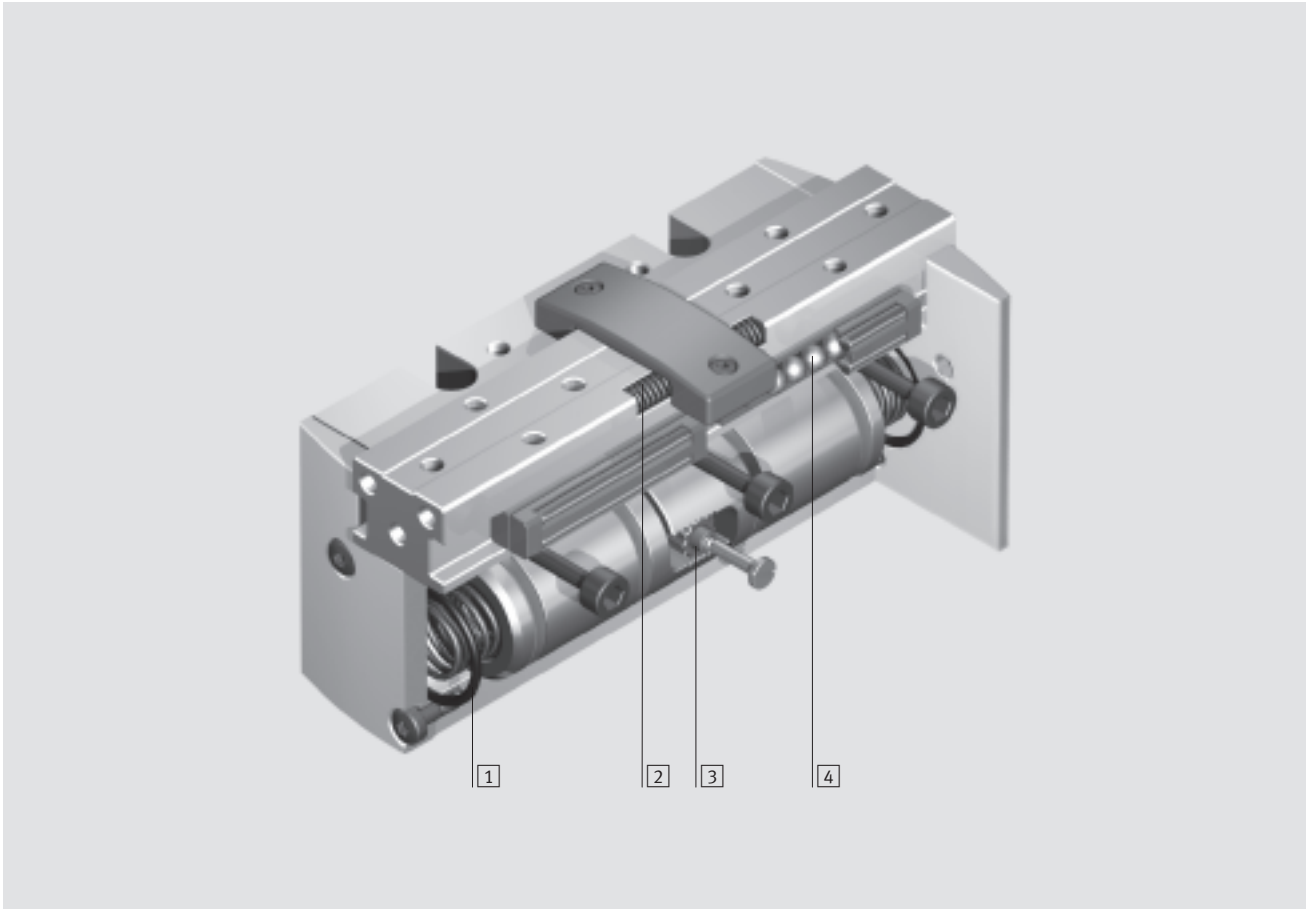

At a glance

- Wide range of variants for greater flexibility:
 - Double-acting piston drive HGPP-...-A.
 - Compression springs for supporting or retaining gripper forces, or for use as a single-acting gripper with only one compressed air connection
 - High precision gripper jaw guide
 - Choice of gripping action
 - External gripping
 - Internal gripping
 - Multiple compressed air connections
 - Integrated sensing electronics
 - Adaptable proximity sensor via mounting bracket
 - Highly flexible thanks to versatile attachment, mounting and applications options
 - Drives
 - Externally adaptable gripper fingers
 - Guide plate
- 1 Compression spring closes gripper jaws: HGPP-...-G2
 - 2 Compression spring opens gripper jaws: HGPP-...-G1
 - 3 Synchronisation element
 - 4 Backlash-free guide bearing



Gripper selection software
www.festo.com/en/engineering

Precision parallel grippers HGPP

Features



Versatile air connections and mounting options

Supply port direct at the front, direct mounting from above

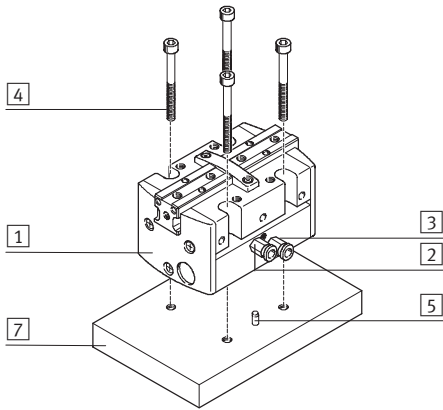

Supply port via adapter plate from underneath, direct mounting from above

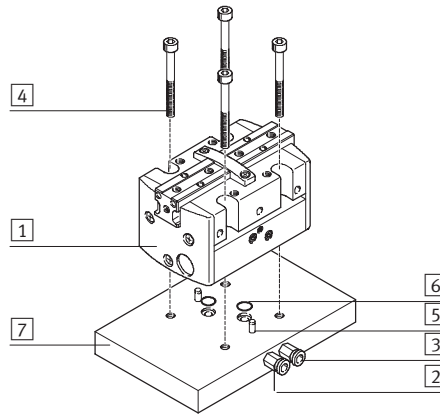

- 1 Precision parallel gripper
- 2 Compressed air connection, opening
- 3 Compressed air connection, closing
- 4 Mounting screws
- 5 Locating pins
- 6 O-rings
- 7 Plate (user-specific)

Range of applications (user-specific)

Attachment of external gripper fingers

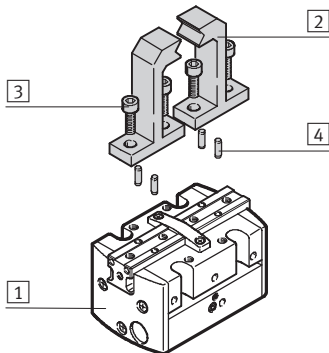

- 1 Precision parallel gripper
- 2 Gripper finger
- 3 Mounting screws
- 4 Locating pins
- 5 Guide plate

Used as guide plate

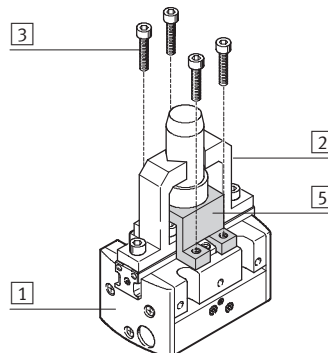

 Note
Precision parallel grippers are not suitable for the following, or for similar applications:

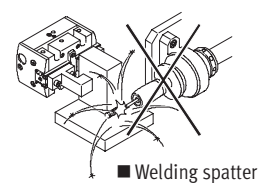
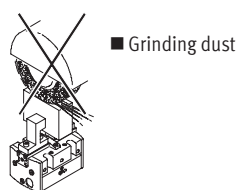
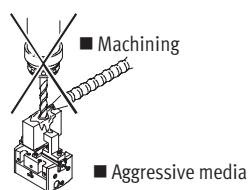

Precision parallel grippers HGPP

System example



System product for handling and assembly technology

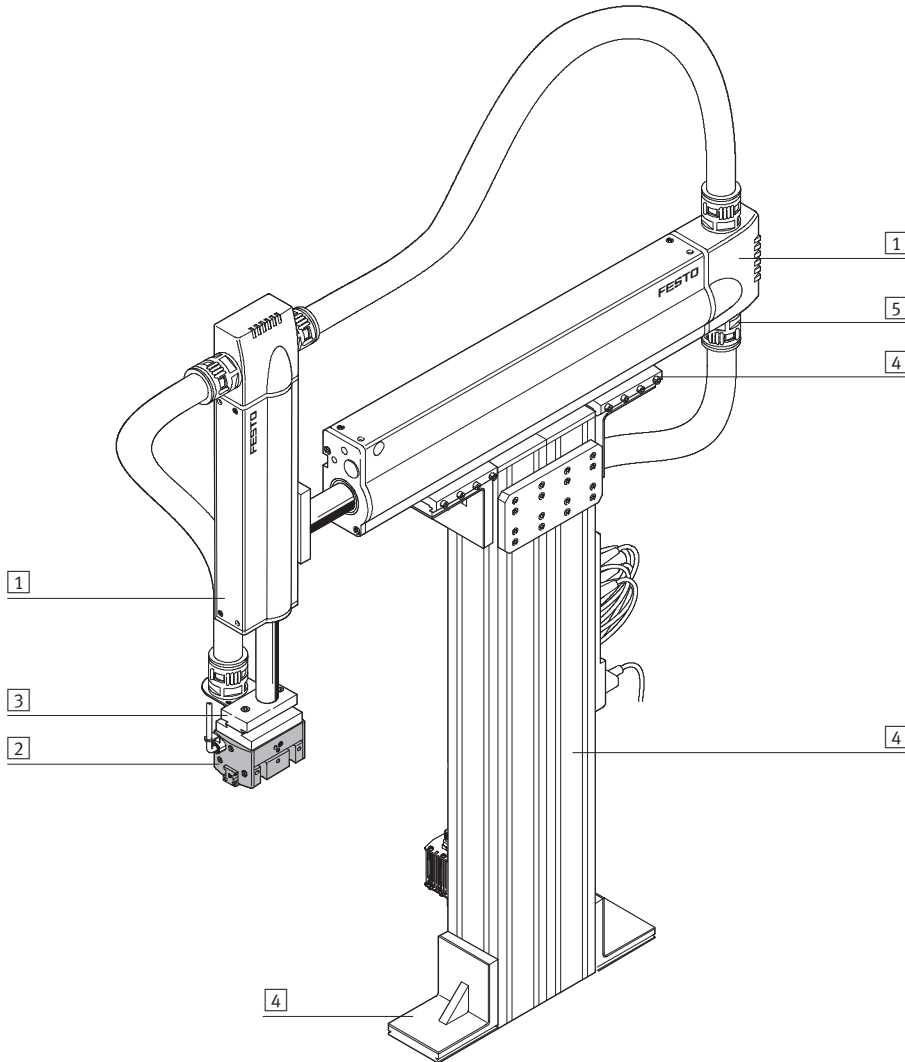

Handling units
Precision grippers

7.6

System elements and accessories			
	Brief description	→ Page	
1	Drives	Wide range of combination options within handling and assembly technology	Volume 1
2	Gripper	Diverse variation options in handling and assembly technology	Volume 1
3	Adapter	For drive/drive and drive/gripper connections	Volume 5
4	Basic mounting components	Profiles and profile connections as well as profile/drive connections	Volume 5
5	Installation components	For achieving a clear-cut, safe layout of electrical cables and tubing	Volume 5
-	Axes	Diverse possible combinations in handling and assembly technology	Volume 5
-	Motors	Servo and stepper motors, with or without gearing	Volume 5

Precision parallel grippers HGPP

Peripherals overview and type codes

Peripherals overview

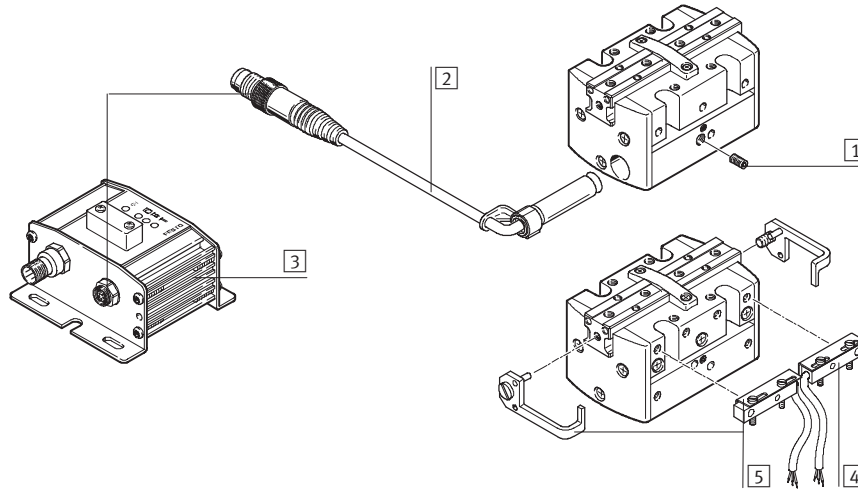

Accessories			
	Brief description	→ Page	
1	Threaded pin	For securing proximity sensors SMH-S1	-
2	Proximity sensor SMH-S1	Can be integrated in the gripper	1 / 7.6-14
3	Evaluation unit SMH-AE1	For proximity sensor SMH-S1, for sensing 3 positions	1 / 7.6-14
4	Proximity sensor SIES-Q5B	Can be assembled with mounting bracket HGPP-HWS-Q5	1 / 7.6-14
5	Mounting bracket HGPP-HWS-Q5	For mounting proximity sensors SIES-Q5B, comprising 1 bracket and 1 switch lug with mounting screws	1 / 7.6-15

Type codes

		HGPP	-	16	-	A	-	G1
Type								
HGPP	Precision parallel gripper							
Size								
Position sensing								
A	Via proximity sensor							
Gripping force retention								
G1	Open							
G2	Closed							

Precision parallel grippers HGPP

Technical data

FESTO

Function
Double-acting
HGPP...-A

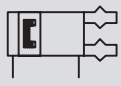



Single-acting or
with gripping force retention ...
... open HGPP...-G1



... closed HGPP...-G2



-  - Size
10 ... 32 mm

-  - Stroke
4 ... 25 mm

-  - [www.festo.com/en/
Spare_parts_service](http://www.festo.com/en/Spare_parts_service)
Wearing parts kits
➔ 1 / 7.6-14



General technical data						
Size	10	12	16	20	25	32
Design	Rack and pinion					
Mode of operation	Double-acting					
Gripper function	Parallel					
Number of gripper jaws	2					
Max. applied load per external gripper finger ¹⁾ [N]	< 0.5	< 1	< 1.5	< 2	< 2.5	< 3
Stroke per gripper jaws [mm]	2	2.5	5	7.5	10	12.5
Pneumatic connection	M3			M5		G1/8/M5 ²⁾
Repetition accuracy ³⁾ [mm]	< 0.02		< 0.015		< 0.01	
Max. interchangeability [mm]	0.2					
Max. gripper jaw backlash [mm]	0					
Max. gripper jaw angular lash [°]	0					
Max. operating frequency [Hz]	4					
Centring precision [mm]	< Ø 0.05					
Position sensing	Via proximity sensor					
Type of mounting	With through-hole and locating pin With female thread and locating pin					

- 1) Valid for unthrottled operation
- 2) Supply port on side G1/8; supply port on ground M5
- 3) End-position drift under constant conditions of use with 100 consecutive strokes in the direction of movement of the gripper jaws

Operating and environmental conditions			
Min. operating pressure	HGPP...-A	[bar]	2
	HGPP...-G...		5
Max. operating pressure		[bar]	8
Operating medium	Filtered compressed air, lubricated or unlubricated		
Ambient temperature ¹⁾		[°C]	+5 ... +60
Corrosion resistance class CRC ²⁾	2		

- 1) Note operating range of proximity sensors
- 2) Corrosion resistance class 2 according to Festo standard 940 070
Components requiring moderate corrosion resistance. Externally visible parts with primarily decorative surface requirements which are in direct contact with a surrounding industrial atmosphere or media such as cooling or lubricating agents

Precision parallel grippers HGPP

Technical data



Weights [g]						
Size	10	12	16	20	25	32
HGPP-...-A	126	172	315	604	884	1408
HGPP-...-G1	127	173	316	611	910	1438
HGPP-...-G2	127	173	317	615	898	1427

Materials

Sectional view

Precision parallel gripper		
1	Housing	Anodised aluminium
2	Gripper jaw	Nickel-plated aluminium
3	Cover cap	Polyacetate
4	Plug cap	Anodised aluminium
–	Note on material	Free of copper, PTFE and silicone

Gripping force [N] at 6 bar

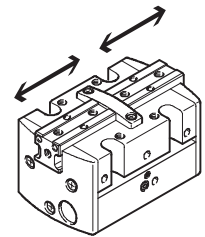

Size	10	12	16	20	25	32
Gripping force per gripper jaw						
Opening	40	58	102	170	250	415
Closing	40	58	102	170	250	415
Total gripping force						
Opening	80	116	204	340	500	830
Closing	80	116	204	340	500	830

Characteristic load values at the gripper jaws

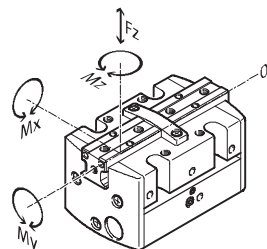

Indicated permissible forces and torques apply to a single gripper jaw. Static forces and torques relate to additional applied loads caused by the workpiece or external gripper fingers, as well as forces which occur

during handling. The zero co-ordinate line (gripper jaws point of rotation) must be taken into consideration for the calculation of torques. Additionally, max. permissible forces

which may be applied to the housing have been entered as well, which, for example, can be absorbed by a guide plate during pressing-in operations.

Size	10	12	16	20	25	32
Max. permissible force $F_{Z\text{Gripper jaws}}$ [N]	40	70	130	220	380	720
Max. permissible force $F_{ZHousing}$ [N]	200	400	600	800	1,000	1,200
Max. permissible torque M_x [Nm]	1.5	3	7	14	21	30
Max. permissible torque M_y [Nm]	1.5	3	7	14	21	30
Max. permissible torque M_z [Nm]	1.5	3	7	14	21	30

Precision parallel grippers HGPP

Technical data



Mass moment of inertia [kgm²x10⁻⁴]

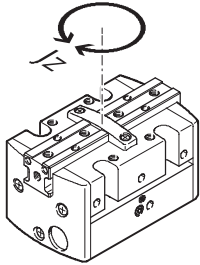

Mass moment of inertia [kgm²x10⁻⁴] for precision parallel grippers in relation to the central axis, without load.

Size	10	12	16	20	25	32
HGPP-...-A	0.43	0.73	2.39	6.22	16.68	38.34
HGPP-...-G1	0.45	0.76	2.58	6.71	17.45	39.21
HGPP-...-G2	0.43	0.74	2.45	6.27	16.85	38.63

Opening and closing times [ms] at 6 bar

without external gripper fingers

with external gripper fingers

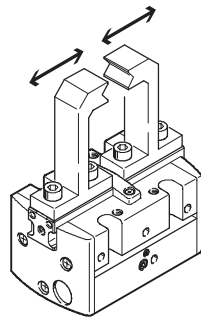
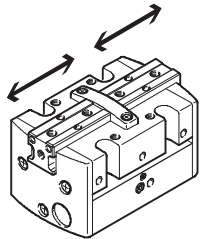

The indicated opening and closing times [ms] have been measured at room temperature and 6 bar operating pressure with vertically mounted gripper and without external gripper fingers. Load is increased if external gripper fingers are attached. This means that kinetic energy is also increased, as this is determined by gripper finger weight and velocity. If permissible kinetic energy is exceeded, various parts of the gripper may be damaged. This occurs when

the applied load reaches the end-position and the cushioning is only able to partially convert the kinetic energy into potential energy and heat energy. It thus becomes apparent that the indicated max. permissible applied load due to the external gripper fingers must be checked and maintained. The grippers must be throttled for greater applied loads. Opening and closing times must then be adjusted accordingly.

Size		10	12	16	20	25	32
Without external gripper fingers							
HGPP-...-A	Opening	22	27	40	44	64	76
	Closing	34	40	53	59	92	110
HGPP-...-G1	Opening	24	30	34	45	58	64
	Closing	95	70	70	92	164	173
HGPP-...-G2	Opening	26	37	57	62	105	103
	Closing	32	40	46	58	90	101
With external gripper fingers as a function of the applied load							
HGPP	1 N	100	–	–	–	–	–
	2 N	200	100	50	–	–	–
	3 N	300	200	100	50	100	–
	4 N	–	300	200	100	150	100
	5 N	–	–	300	200	200	150
	6 N	–	–	–	–	300	250

Precision parallel grippers HGPP

Technical data

Gripping force F_H as a function of operating pressure and the lever arm x

Gripping forces related to operating pressure and lever arm can be determined for the various sizes with the following graphs.

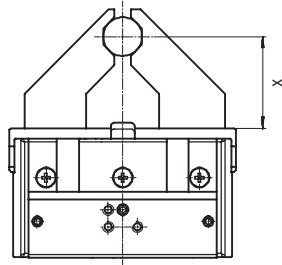

HGPP-10-A

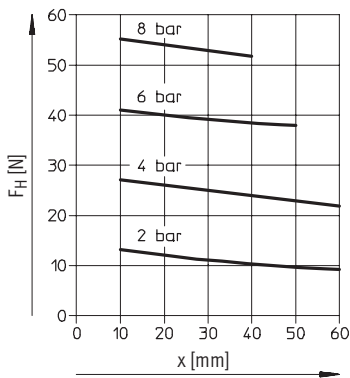

HGPP-12-A

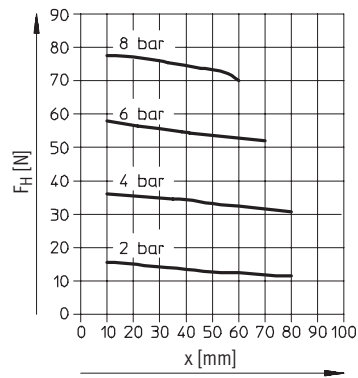

HGPP-16-A

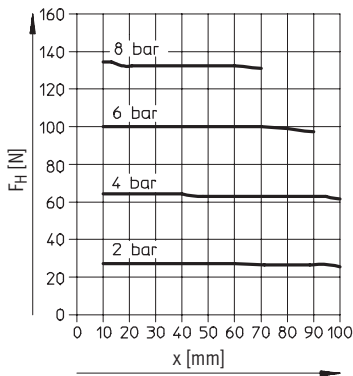

HGPP-20-A

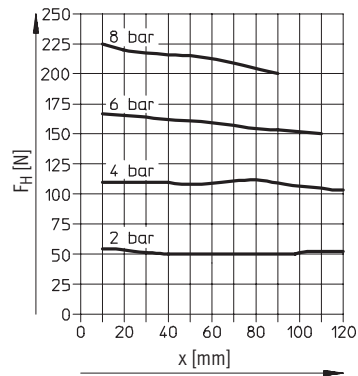

HGPP-25-A

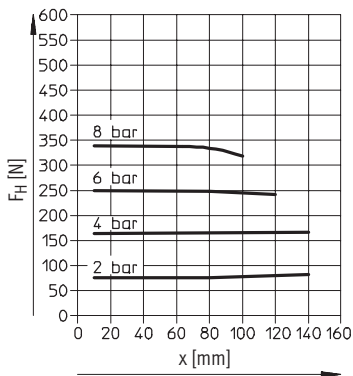

HGPP-32-A

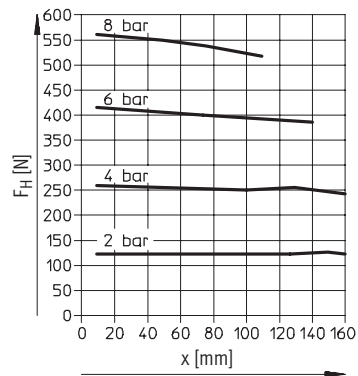

Precision parallel grippers HGPP

Technical data



Spring force F_F as a function of the gripper size and overall stroke length l

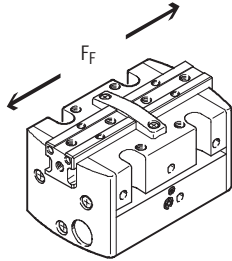

Gripper retention force, opening: the spring forces F_F of the precision parallel gripper HGPP-...-G1 can be determined from the following graphs.

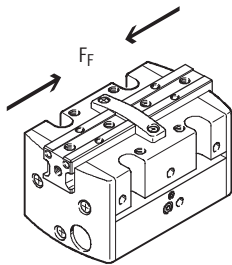
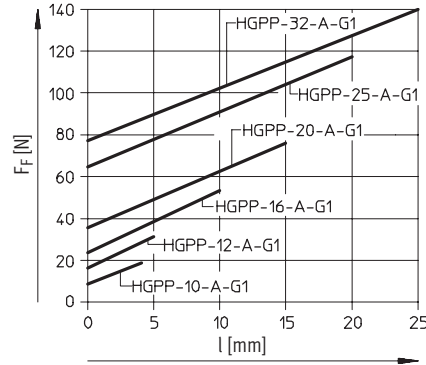

Gripper retention force, closing: the spring forces F_F of the precision parallel gripper HGPP-...-G2 can be determined from the following graphs.

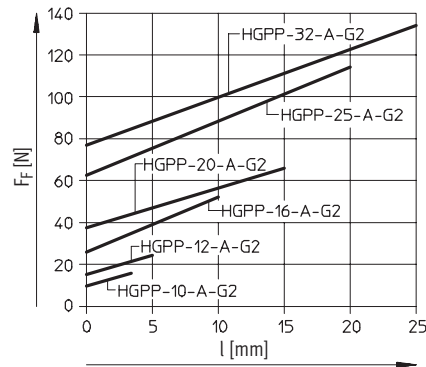

Determination of actual gripping forces for HGPP-...-G1 and HGPP-...-G2 depending upon the application

The precision parallel grippers with integrated spring can be used as:

- single-acting grippers
- grippers with supplementary gripping force and
- grippers with gripping force retention

In order to calculate available gripping forces F_{Gr} (per gripper jaw), gripping force (F_H) and spring force (F_F) must be combined accordingly.

Application

The resulting gripping force F_{Gr} , conditional on the application, depends on the gripping action (external/internal gripping) and the gripper design (with/without spring return). The spring force is supplemented in accordance with the design and gripping action.

Single-acting

- Gripping with spring force:
 $F_{Gr} = F_F$
- Gripping with pressure force:
 $F_{Gr} = F_H - F_F$

Supplementary gripping force

- Gripping with pressure and spring force:
 $F_{Gr} = F_H + F_F$

Gripping force retention

- Gripping with spring force:
 $F_{Gr} = F_F$

		Pressurised (in gripping action)	Unpressurised
HGPP-...-A	Internal gripping	$F_{Gr} = F_H$	$F_{Gr} = 0$
	External gripping	$F_{Gr} = F_H$	$F_{Gr} = 0$
HGPP-...-G1	Internal gripping	$F_{Gr} = F_H + F_F$	$F_{Gr} = F_F$
	External gripping	$F_{Gr} = F_H - F_F$	$F_{Gr} = 0$
HGPP-...-G2	Internal gripping	$F_{Gr} = F_H - F_F$	$F_{Gr} = 0$
	External gripping	$F_{Gr} = F_H + F_F$	$F_{Gr} = F_F$

Precision parallel grippers HGPP

Technical data



Gripping force F_H at 6 bar as a function of lever arm x and eccentricity y

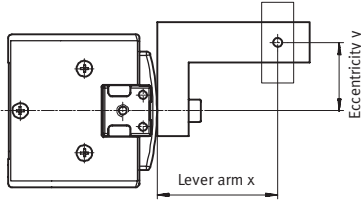

Gripping forces at 6 bar dependent upon eccentric application of force and the maximum permissible off-centre point of force application can be determined for the various sizes using the following graphs.

Calculation example

Given:

Gripper HGPP-12-A

Lever arm $x = 20$ mm

Eccentricity $y = 22$ mm

To be found:

Gripping force at 6 bar

Procedure:

- Determine the intersection xy between lever arm x and eccentricity y in the graph for HGPP-12-A
- Draw an arc (with centre at origin) through intersection xy .
- Determine the intersection between the arc and the X axis.
- Read gripping force

Result:

Gripping force = approx. 55 N

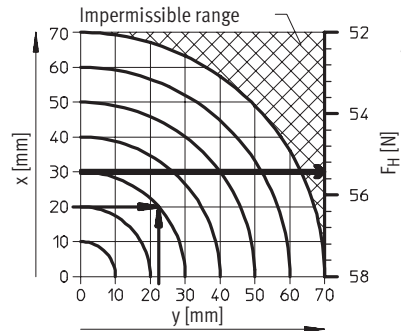

HGPP-10-A

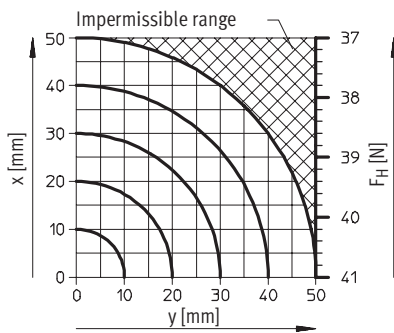

HGPP-12-A

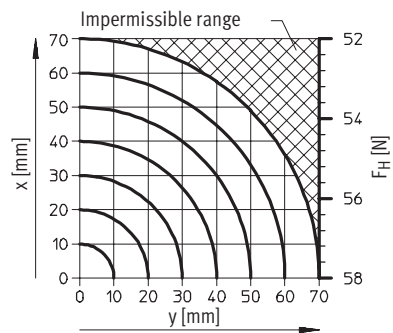

HGPP-16-A

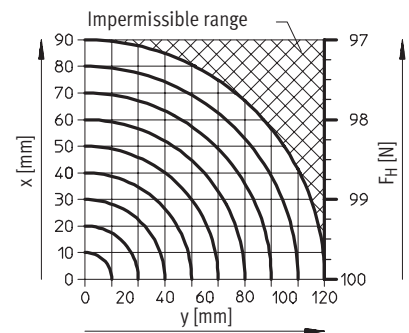

HGPP-20-A

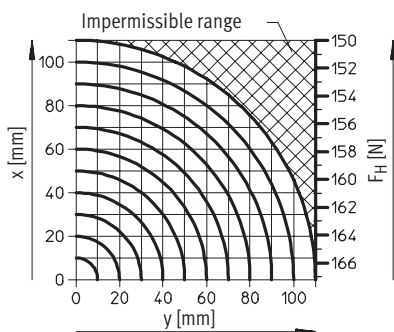

HGPP-25-A

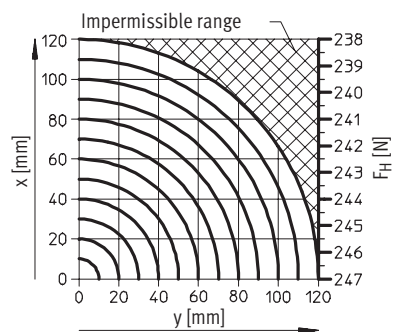

HGPP-32-A

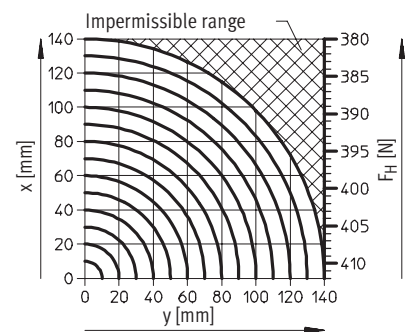

Precision parallel grippers HGPP

Technical data

FESTO

Dimensions

Download CAD data → www.festo.com/en/engineering

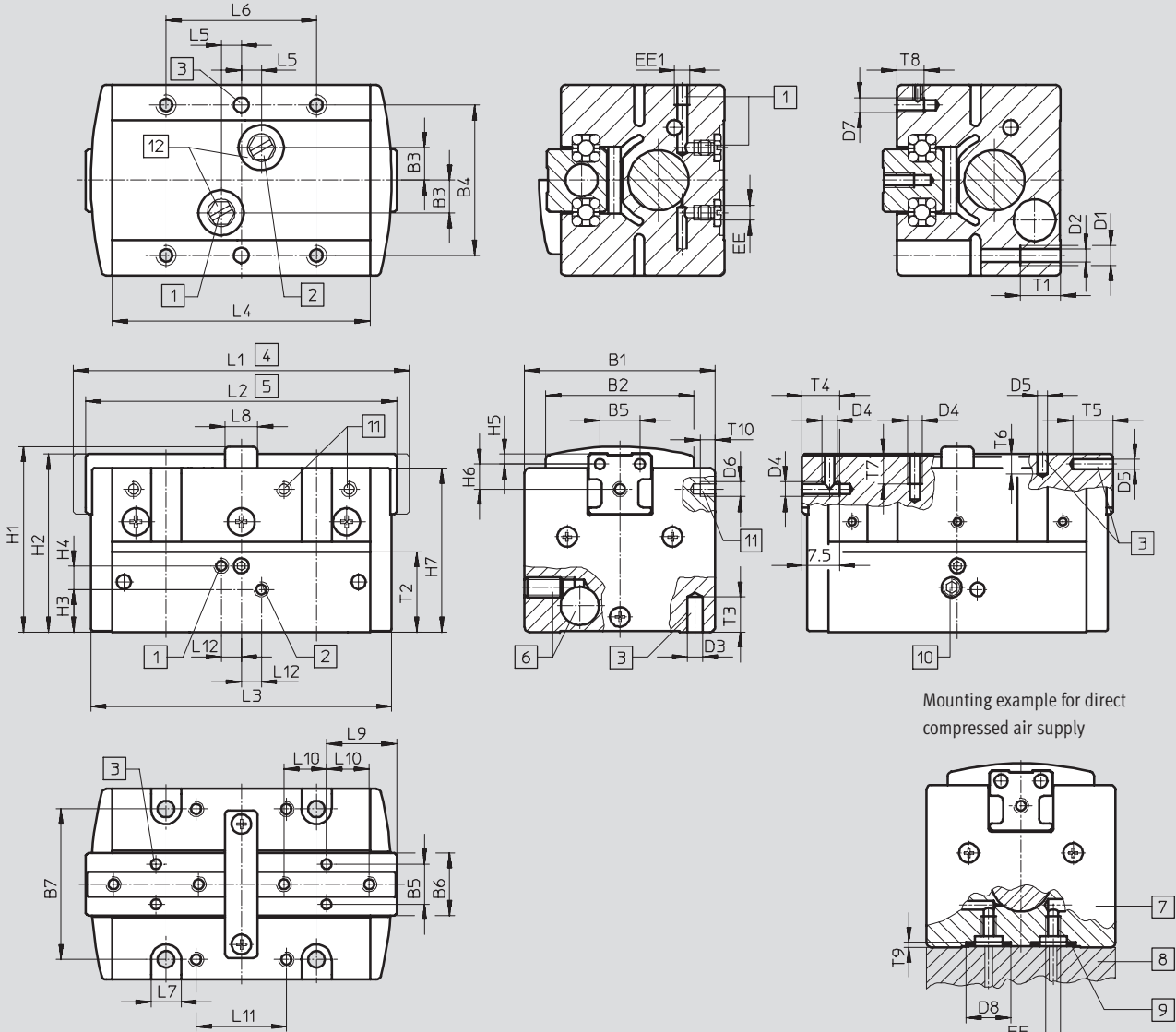

Mounting example for direct compressed air supply

- | | | | |
|--|--|---|---|
| <p>1 Compressed air connection, opening</p> <p>2 Compressed air connection, closing</p> <p>3 Hole for locating pin (Locating pins are not included in scope of delivery.)</p> <p>4 Gripper jaws open</p> | <p>5 Gripper jaws closed</p> <p>6 Hole for sensor kit</p> <p>7 Precision parallel gripper</p> <p>8 Adapter (e. g. customer-specific)</p> | <p>9 O-ring for precision parallel grippers:
 HGPP-10: \varnothing 5.5x1.5
 HGPP-12: \varnothing 5.5x1.5
 HGPP-16: \varnothing 8.13x1.78
 HGPP-20: \varnothing 8.13x1.78
 HGPP-25: \varnothing 8.13x1.78
 HGPP-32: \varnothing 8.13x1.78
 (Not included in scope of delivery)</p> | <p>10 Set screw for mounting proximity sensor SMH-S1</p> <p>11 Thread for securing the mounting bracket HGPP-HWS-Q5</p> <p>12 Supply ports on base sealed on delivery</p> |
|--|--|---|---|

Precision parallel grippers HGPP

Technical data

FESTO

Size	B1	B2	B3	B4 ±0.02 ¹⁾	B5	B6	B7	D1	D2 ∅
[mm]	+0.3	±0.1	±0.05	±0.1 ²⁾	±0.02	±0.1	±0.1		+0.1
10	33	26	6.5	27	8	12.5	27	M4	3.3
12	38	29.5	6.5	30	8	12.5	30	M4	3.3
16	42	30.5	8.5	32	10	16	32	M4	3.3
20	48	36.5	10	40	12	20	40	M5	4.2
25	55	42	12	45	15	25	45	M6	5.1
32	62	45	14	52	18	30	52	M6	5.1

Size	D3 ∅	D4	D5 ∅	D6	D7	D8 ∅	EE	EE1	H1
[mm]	H8		H8			H11			
10	3	M3	2	M2	M3	9	M3	M3	32.7 ±0.15
12	3	M3	2	M2	M3	9	M3	M3	37 +0.3/-0.1
16	3	M3	2.5	M2	M3	12.1	M5	M5	42.5 +0.4/-0.1
20	3	M4	3	M2	M3	12.1	M5	M5	55.5 +0.4/-0.1
25	5	M5	4	M2	M3	12.1	M5	M5	57.5 ±0.15
32	5	M6	5	M2	M4	12.1	M5	G ¹ / ₈	68.6 ±0.15

Size	H2	H3	H4	H5	H6	H7	L1	L2	L3	L4
[mm]	±0.1		±0.1	±0.02	±0.12	-0.3	±0.5	±0.5	±0.25	±0.05
10	31.4	8.9 ±0.25	3.7	2	2.6	28.7	62	58	56	47.4
12	35.5	8.5 ±0.3	4.7	2	5	32.7	67	62	60	51.4
16	40.9	8.3 ±0.2	6.8	3	5	37.1	98	88	86	76
20	53.48	15.5 ±0.2	8	3	7	48.5	120	105	103	92
25	56	12.5 ±0.25	7.5	4	8	51	163	143	139.4	127.4
32	67	12.5 ±0.25	11	5	9	60.5	197.4	172.4	169.4	155.4

Size	L5	L6	L7	L8	L9	L10	L11	L12	T1
[mm]	±0.05	±0.1		±0.1	±0.02	±0.05	±0.1	±0.05	
10	5	27	6	6	13.5	7.5	15	4	8
12	4	30	6	6.5	14	8.5	18	4	8
16	6.5	40	6	12	17.5	11.5	24	6.5	10
20	7.5	40	8	18	21	13.5	26	7.5	12
25	12	45	9	22	29.8	17	28	12	12
32	15	52	9	27	33.5	20	35	15	12

Size	T2	T3	T4	T5	T6	T7	T8	T9	T10
[mm]								+0.1	
10	14.85	6	8	5	4	6	3.8	1	3
12	16	6	7.5	5	4	6	5.5	1	3
16	19.5	7	8	6	4.5	6	5	1.3	4
20	28.5	7	10	8	7	8	6	1.3	7
25	27	10	10	8	8	10	6	1.3	8
32	34.5	10	10	10	10	10	8	1.3	8

1) For locating hole

2) For thread and through-holes



Precision parallel grippers HGPP

Ordering data and accessories



Ordering data					
Size [mm]	Double-acting Without compression spring		Single-acting or with gripping force retention		
	Part No.	Type	open		closed
	Part No.	Type	Part No.	Type	Part No. Type
10	525 658	HGPP-10-A	525 659	HGPP-10-A-G1	525 660 HGPP-10-A-G2
12	187 867	HGPP-12-A	187 868	HGPP-12-A-G1	187 869 HGPP-12-A-G2
16	187 870	HGPP-16-A	187 871	HGPP-16-A-G1	187 872 HGPP-16-A-G2
20	187 873	HGPP-20-A	187 874	HGPP-20-A-G1	187 875 HGPP-20-A-G2
25	525 661	HGPP-25-A	525 662	HGPP-25-A-G1	525 663 HGPP-25-A-G2
32	525 664	HGPP-32-A	525 665	HGPP-32-A-G1	525 666 HGPP-32-A-G2

Ordering data – Wearing parts kits		
Size [mm]	Part No.	Type
10	673 172	HGPP-10
12	673 173	HGPP-12
16	673 174	HGPP-16
20	673 175	HGPP-20
25	673 176	HGPP-25
32	673 177	HGPP-32

Ordering data – Accessories				
	Size [mm]	Weight [g]	Part No.	Type
Proximity sensor SMH-S1 Technical data → 1 / 10.2-102				
	10, 12	20	189 040	SMH-S1-HGPP10/12
	16	20	189 041	SMH-S1-HGPP16
	20, 25	20	189 042	SMH-S1-HGPP20/25
	32	20	526 895	SMH-S1-HGPP32
Evaluation unit SMH-AE1 Technical data → 1 / 10.2-105				
	10 ... 32	170	175 708	SMH-AE1-PS3-M12
		170	175 709	SMH-AE1-NS3-M12
Proximity sensor SIES-Q5B Technical data → Volume 4				
	10 ... 32	22	178 291	SIES-Q5B-PS-K-L
		22	174 549	SIES-Q5B-PO-K-L
		22	178 290	SIES-Q5B-NS-K-L
		22	174 548	SIES-Q5B-NO-K-L

 Core Range

Precision parallel grippers HGPP

Accessories



Dimensions – Mounting bracket

Download CAD data → www.festo.com/en/engineering

HGPP-HWS-Q5

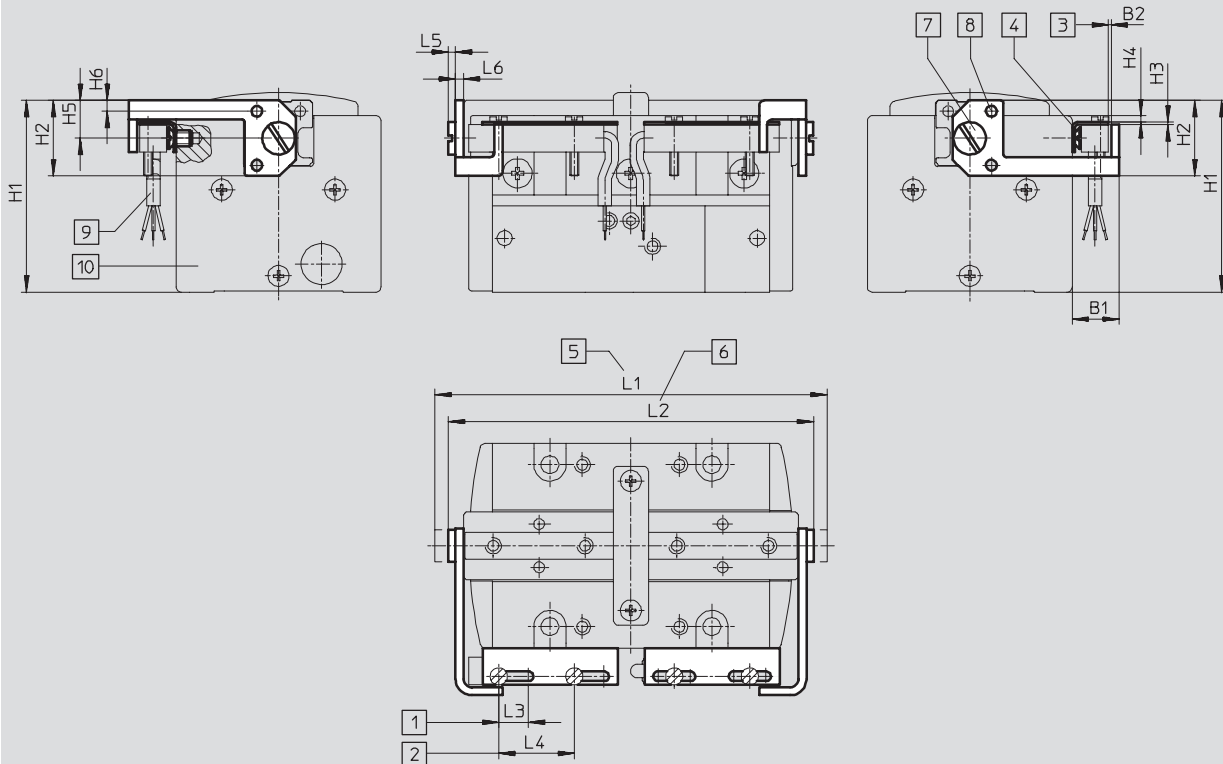

- | | | | |
|---|--|---|--|
| 1 Adjusting range for position sensing | 3 Switching distance | 7 Fixing screw for mounting bracket | 10 Precision parallel grippers HGPP |
| 2 Mounting space for proximity sensor SIES-Q5B | 4 Mounting for sensor bracket | 8 Locating pin | |
| | 5 Gripper jaws position, open | 9 Proximity sensor SIES-Q5B (to be ordered separately) | |
| | 6 Gripper jaws position, closed | | |

For size	B1	B2	H1	H2	H3	H4	H5	H6
[mm]								
10	8.7	0.5	35.5	14	0.5	1.2	7	2
12	8.7	0.5	35.5	14	0.5	1.2	7	2
16	8.5	0.5	35.4	16	0.5	1.2	8	3
20	8.5	0.5	36	20	0.5	2	10	3
25	9.5	0.55	46.3	24	1	3.7	12	4
32	9.5	0.55	55.5	28	1	4	14	5

For size	L1	L2	L3	L4	L5	L6	Weight	Part No.	Type
[mm]							[g]		
10	67.6	63.6	5.5	14	1.5	1.3	4.2	532 272	HGPP-HWS-Q5-1
12	73.6	68.6	5.5	14	1.5	1.8	5.6	532 273	HGPP-HWS-Q5-2
16	105.6	95.6	8.5	14	2	1.8	8.3	532 274	HGPP-HWS-Q5-3
20	126.8	111.8	8.5	14	2	1.4	11.4	532 275	HGPP-HWS-Q5-4
25	171	151	28	14	2	2	17.6	532 276	HGPP-HWS-Q5-5
32	206.6	181.6	28	14	2	2.6	24.6	532 277	HGPP-HWS-Q5-6